

# Spatial variations in the distribution of trace ionic impurities in the water–steam cycle in a thermal power plant based on a multivariate statistical approach

## Research Article

Dragana Z. Živojinović<sup>1\*</sup>, Vladana N. Rajaković-Ognjanović<sup>2</sup>,  
Antonije E. Onjia<sup>3</sup>, Ljubinka V. Rajaković<sup>1</sup>

<sup>1</sup>Department of Analytical Chemistry and Quality Control,  
Faculty of Technology and Metallurgy, University of Belgrade,  
11000 Belgrade, Serbia

<sup>2</sup>Faculty of Civil Engineering, University of Belgrade,  
11000 Belgrade, Serbia

<sup>3</sup>Vinča Institute of Nuclear Sciences, University of Belgrade,  
11001 Belgrade, Serbia

Received 24 December 2012; Accepted 29 April 2013

**Abstract:** In this study, a multivariate statistical approach was used to identify the key variables responsible for process water quality in a power plant. The ion species that could cause corrosion in one of the major thermal power plants (TPP) in Serbia were monitored. A suppressed ion chromatographic (IC) method for the determination of the target anions and cations at trace levels was applied. In addition, some metals important for corrosion, *i.e.*, copper and iron, were also analysed by the graphite furnace atomic absorption spectrophotometric (GFAAS) method. The control parameters, *i.e.*, pH, dissolved oxygen and silica, were measured on–line. The analysis of a series of representative samples from the TPP Nikola Tesla, collected in different plant operation modes, was performed. Every day laboratory and on–line analysis provides a large number of data in relation to the quality of water in the water–steam cycle (WSC) which should be evaluated and processed. The goal of this investigation was to apply multivariate statistical techniques and choose the most applicable technique for this case. Factor analysis (FA), especially principal component analysis (PCA) and cluster analysis (CA) were investigated. These methods were applied for the evaluation of the spatial/temporal variations of process water and for the estimation of 13 quality parameters which were monitored at 11 locations in the WSC in different working conditions during a twelve month period. It was concluded that PCA was the most useful method for identifying functional relations between the elements. After data reduction, four main factors controlling the variability were identified. Hierarchical cluster analysis (HCA) was applied for sample differentiation according to the sample location and working mode of the TPP. On the basis of this research, the new design of an optimal monitoring strategy for future analysis was proposed with a reduced number of measured parameters and with reduced frequency of their measurements.

**Keywords:** Ionic impurities • Water–steam cycle • Ion chromatography • Principal component analysis • Hierarchical cluster analysis

© Versita Sp. z o.o.

## 1. Introduction

The monitoring of trace level of ionic impurities throughout the power generation process is critical for the identification and prevention of corrosive processes in many power plant components. The measurements and control of impurities, such as sodium, chloride, silica and other ionic species, even at low ( $\mu\text{g L}^{-1}$ )

levels, in the whole water–steam cycle (WSC), provides valuable information regarding the source of contamination, the likely rates of contaminant build-up, and probable rates of corrosion and timely data during the start-up and shut-down of thermal power plants (TPP).

Water for the WSC is provided either from groundwater sources (wells) or from surface water (rivers). Water is

\* E-mail: gaga@tmf.bg.ac.rs

prepared in the chemical water treatment plant (CWTP). The final result should be ultra pure water suitable for use in the WSC.

Ion chromatography (IC) has become an important technique for monitoring water quality and for the determination of ionic species with respect to corrosive ions, at sub- to low ( $\mu\text{g L}^{-1}$ ) levels [1–9]. The method for anion determination and control was developed in previous research [10]. The developed IC method was tested on real samples from a TPP and its validation was performed [11]. In these previous research, all the advantages of the adopted IC method are described in detail, as well as what are the benefits of the analysis of trace ions in such a complex matrix such as the water–steam samples.

To control the quality of process water in the power plant, two sets of parameters are important: the control and diagnostic parameters. The control parameters were; pH value, conductivity, oxygen, sodium, chloride and silica. The diagnostic parameters were; iron, copper, organic matter and oil. These water quality parameters require precise and rapid measurement at critical points in the WSC, in order to obtain information about the current state of water and steam quality, to start-up quick actions to reduce these concentrations and prevent formation of corrosion deposits. The limiting values for the control and diagnostic parameters of process water quality in the TPP “Nikola Tesla” (Serbia) were described in previous research [12,13].

In ultrapure water all impurities in cationic, anionic and molecular form should be removed or reduced to the lowest possible level. The monitoring and measuring of ionic species and the other impurities in the process water is very important for the prevention of corrosion processes.

In the many studies [14–17], methods for the determination of cations that may be indicators of corrosion, such as sodium, iron and copper, have been developed. The influence of each ion and molecule in ultrapure water on corrosion processes and forming of deposits ( $\text{Na}_2\text{O}\cdot\text{Fe}_2\text{O}_3\cdot 4\text{SiO}_2$ ,  $\text{Na}_2\text{O}\cdot 4\text{CaO}\cdot 6\text{SiO}_2\cdot \text{H}_2\text{O}$ ,  $\text{Cu}_2\text{O}$ ,  $\text{CuO}$ ,  $\text{Fe}_3\text{O}_4$ ,  $\text{Fe}_2\text{O}_3$ ) was discussed previously [18]. Deposits, such as iron silicates, are also present in the boiler. These deposits are adherent, robust solids and hard to remove and they cause breakage of boiler pipes. The sources of boiler deposits are corrosion products, such as magnetite ( $\text{Fe}_3\text{O}_4$ ) and hematite ( $\text{Fe}_2\text{O}_3$ ). As contradictory as it may seem, a layer of magnetite is desirable as protection from further corrosion.

One representative example which should be emphasized is the presence of silica. Silica can exist in three physico-chemical forms in water, *i.e.*, the monomer

silica (soluble reactive), polymeric silica (colloidal reactive) and suspended silicon. Ultrapure water can contain silica in one of these three forms, and they can vary depending on the acidity/alkalinity of water [19]. These compound can exist in equilibrium, which can be presented as shown in equation:

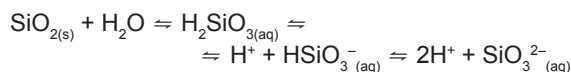

Solubility of silica in water depends on many factors, such as temperature, pressure, pH-value and ionic strength.

Silica combines with a wide variety of elements to produce silicates or it may form deposits on its own (for example:  $\text{SiO}_2$ ,  $\text{Na}_2\text{SiO}_3\cdot 9\text{H}_2\text{O}$ ,  $\text{NaFeSi}_2\text{O}_6$ ,  $\text{Mg}_6\text{I}(\text{OH})_8\text{Si}_4\text{O}_{10}$ ). Silicates form tenacious deposits in cooling water systems, boiler tubes and on turbine blades. The scales are inert to most chemical cleaning solutions, with exception of HF. This is an extremely dangerous compound, which makes the prevention of silica deposition even more important.

The water purification line in the TPP Nikola Tesla, with particular emphasis on the processes and procedures to reduce or remove silicon ions and silica compounds, is shown in Fig. 1.

In the study of the effect of anions on corrosion processes in the TPP, it was found that the chloride ions are the main causes of corrosion.  $\text{Cl}^-$  ion has a negative influence on the whole water–steam cycle, especially affecting the corrosion of the turbine blades causing stress, acid and pitting corrosion [11]. Chloride attacks metal surface and provoke corrosion at local region as an autocatalytic process of pitting corrosion [20]. In a high pressure atmosphere, it is excellent indicator for steam purity. The chloride ion is extremely reactive and increases corrosion processes.

In this study multivariate statistical techniques, such as principal component analysis, factor analysis and cluster analysis were applied for the evaluation of spatial variations in the distribution of water quality parameters in the TPP and for the interpretation of a data set obtained by monitoring of 13 parameters in three different operation modes at 11 selected points in the WSC. Based on a multivariate statistical approach were obtained useful information about the similarities or differences between monitoring stations and sampling periods, to identify key variables for spatial differences in water quality and the impact of the pollution sources on water quality parameters. The many papers demonstrated that multivariate statistical methods is effective for river water classification, and for rapid assessment of water qualities necessary for management of water resources

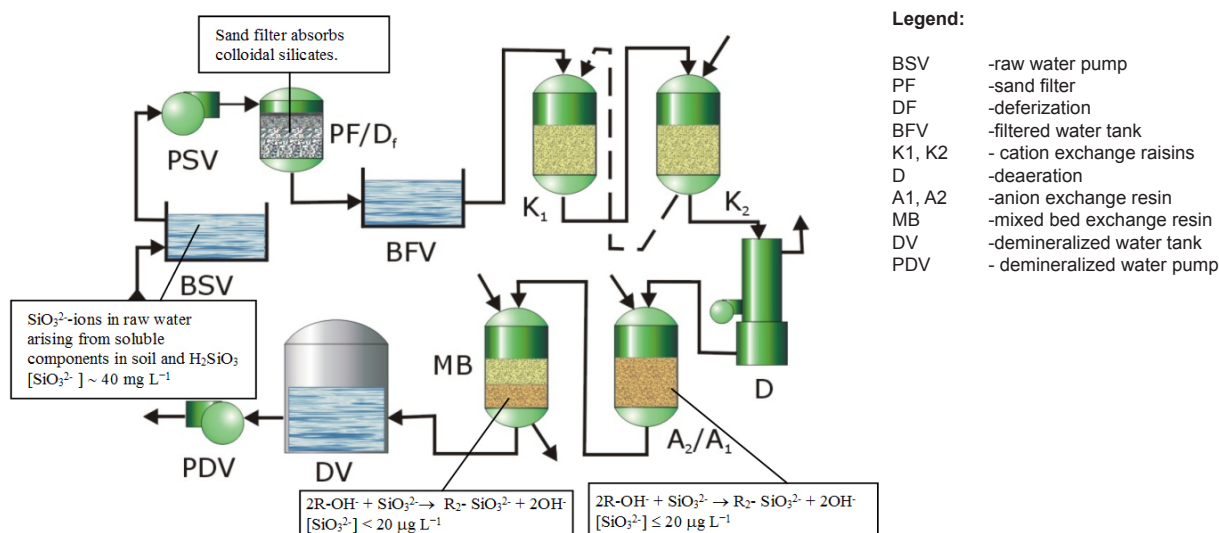

**Figure 1.** Water purification line in the TPP Nikola Tesla, removal of silicon from raw water.

it could serve to optimize cost and time for monitoring of: river water [21-23], marine water [24] and drinking water [25,26].

## 2. Experimental procedure

### 2.1. Water–steam cycle in the power plant

The investigated WSC consists of a polishing plant (PP), a feed water tank (FWT), a boiler (B), a turbine (T) and a condenser (C). The conditions within the WSC are extreme, with high pressures and temperatures. Due to the loss of condensate (caused by evaporation or leakage) in the WSC, demineralised water from the FWT is continuously added. Deaerated water in the FWT is the source for steam generation, produced in the boiler. Steam, with a certain temperature and pressure, enters the turbine. A more detailed scheme of the WSC in the TPP Nikola Tesla, which has already been the subject of previous studies, is presented in Fig. 2 [11].

### 2.2. Water sampling

#### 2.2.1. Chemical reagents

All chemicals for the preparation of the IC eluents and standard solutions were of analytical–reagent grade and dissolved in deionised water. Standard solutions were prepared with a Merck (CertiPur) multi–element standard solution. The following standards were used: multi–element standard VII for cation chromatography, concentration 100 mg L<sup>-1</sup> (Li, Na, NH<sub>4</sub>, K, Mg, Ca, Mn, Sr, Ba in diluted nitric acid); single anion standards, concentration 1000 mg L<sup>-1</sup>; GFAAS multi element standard XVIII, concentration 1000 mg L<sup>-1</sup> (16 elements in diluted nitric acid).

The stock standard solutions (concentrations 1000 mg L<sup>-1</sup>) were stored at 4°C. Standard working solutions of lower analyte concentrations (<100 µg L<sup>-1</sup>) were prepared daily by diluting the stock solutions with deionised water. Fresh working eluents Na<sub>2</sub>CO<sub>3</sub>/NaHCO<sub>3</sub>, NaOH and methanesulphonic acid, CH<sub>3</sub>SO<sub>3</sub>H, (Fluka Chemika) were prepared daily, filtered through 0.2 µm pore size membrane filters (Millipore, USA) and degassed, prior to use.

Deionised water with a specific resistance of 18.2 MΩ cm (Milli Q) was used to prepare all the solutions. All calibration standards and spiked samples were stored in polyethylene containers which had been thoroughly cleaned and pre–soaked in deionised water for 24 h and rinsed several times prior to use [27–29].

#### 2.2.2. Samples and procedures

A scheme of the water–steam cycle of the TPP Nikola Tesla, Serbia is shown in Fig. 2 with the sampling points indicated. Each sampling point, as well as the type of water, is described in the legend given below Fig. 2. Some parameters, *i.e.*, pH values, conductivity and oxygen, were measured on–line. The other parameters were measured in the laboratory. Samples measured in laboratory were handled carefully to avoid contamination and analyzed as quickly as possible. These samples were analyzed without any pre–treatment, except for filtering for the IC measurements. 33 samples were collected and analyzed. Samples labelled with numbers 1 to 11 were collected under normal operating conditions; samples labelled with numbers 12 to 22 were collected in the phase of block moving and samples labelled with numbers from 23 to 33 were collected at the moment of block start–up. All samples were collected at different

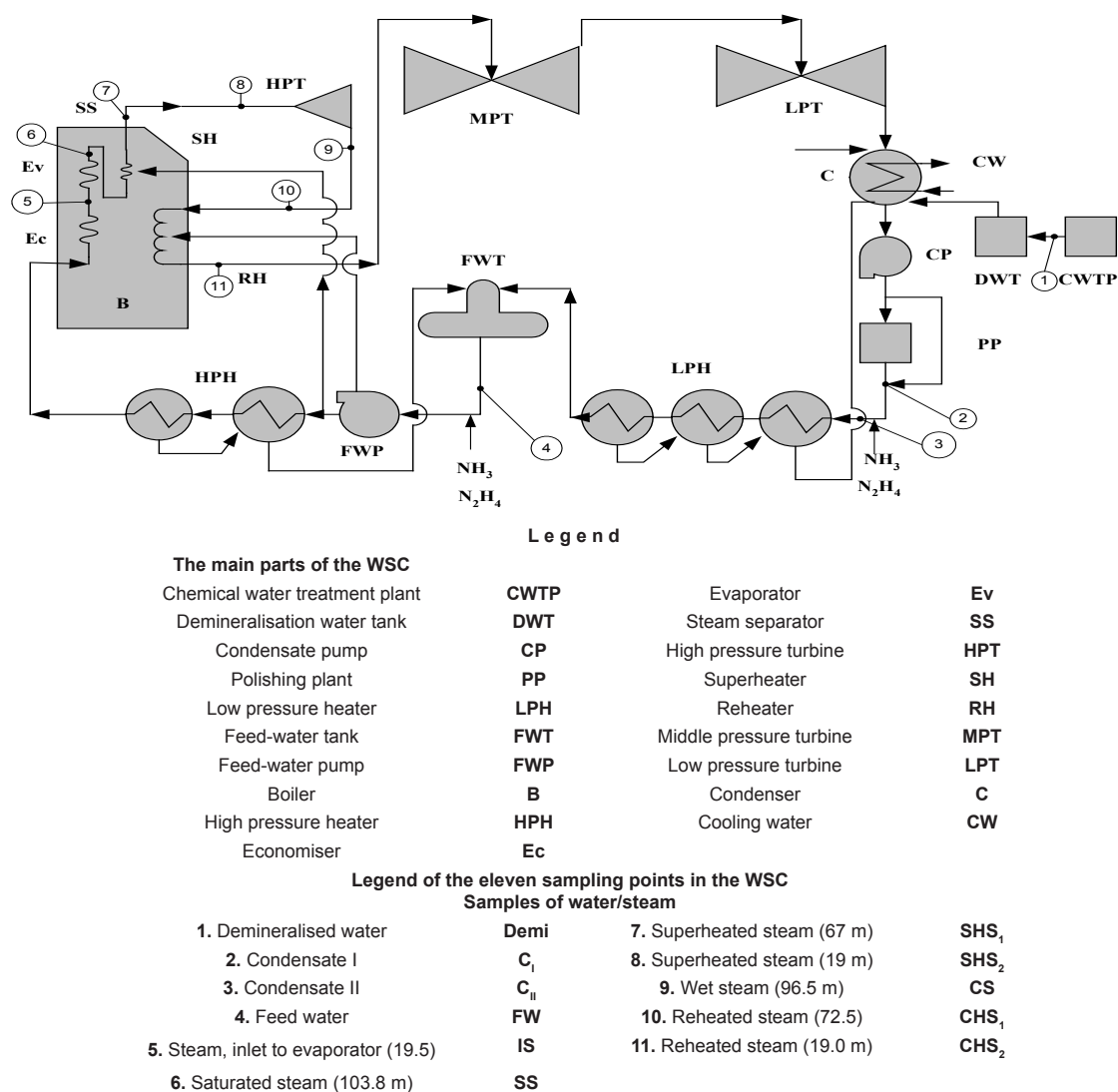

**Figure 2.** A scheme of the WSC of the TPP Nikola Tesla.

working conditions and collected from 11 characteristic points in the water-steam cycle, as shown and marked in Fig. 2.

### 2.3. Instrumentation

The monitoring of the control and diagnostic parameters of the water quality in a TPP requires the use of highly sensitive and reliable instruments. For pH measurements, two types of instruments were used: an on-line (Polymetron 8271) and a laboratory pH-meter (pH-metar RADIOMETER M-61, pH-metar KRICK Por Tames 911 pH). Dissolved oxygen was measured using an on-line (OKSISPHERE 2713, 3600) and a laboratory (HQ 40d multi HACH) electrode. The contents of iron and copper were determined by graphite furnace atomic absorption spectrometry (GFAAS, Perkin-Elmer Model

5000 with an electrothermal atomization HGA-400;  $\lambda$ : 324.8 nm slit 0.7 nm for Cu and 248.3 nm slit 0.2 nm for Fe; the sample volume was 20  $\mu$ L). The temperature programmes of the graphite furnace used for Cu and Fe determination are listed in Table 1. For the determination of the content of cations and anions, a Dionex DX 100 IC system (Dionex, Sunnyvale, CA, USA) consisting of an IP20 isocratic pump and a CD20 conductivity detector was used. A sample loop with a volume of 1000  $\mu$ L was made from a poly(ether ether ketone) (PEEK) tube of length of 210 cm and I.D. 0.750 mm. Its volume was verified by measuring the mass difference between the sample loop filled with deionised water and the empty loop. Details of the operating conditions of the IC system were described in detail previously [11].

**Table 1.** The temperature program for the determination of Cu and Fe by GFAAS method.

Phase	Temperature (°C)	t <sub>ramp</sub> (s)	t <sub>retention</sub> (s)	Gas flow (mL/min argon)
<b>Drying</b>	110	10	30	1500
<b>Mineralization</b>	(Fe) 600 (Cu) 600	5	10	1500
<b>Atomization</b>	(Fe) 2400 (Cu) 2300	0	7	stop flow
<b>Cleaning</b>	2650	2	2	1500

**Table 2.** Control and diagnostic water quality parameters, characteristic value and analytical methods within the WSC of the TPP Nikola Tesla [13,30].

Water quality parameter	Characteristic value	Monitoring frequency	Analytical tool
<b>Control parameters</b>			
● pH	8.8–9.2	C	pH-meter, on line
● Oxygen, O <sub>2</sub>	10–20 µg L <sup>-1</sup>	C	Oxygen-meter, on line
● Sodium, Na	≤10 µg L <sup>-1</sup>	C	Sodium-meter, on line IC in the laboratory
● Chloride, Cl	≤20 µg L <sup>-1</sup>	C/D	Chloride-meter, on line IC in the laboratory
● Silicon, Si	≤20 µg L <sup>-1</sup>	C/D	Sodium-meter, on line
<b>Diagnostic parameters</b>			
■ Iron, Fe	≤20 µg L <sup>-1</sup>	D/W	GFAAS
■ Copper, Cu	≤3 µg L <sup>-1</sup>	D/W	GFAAS

Legend: C-Continuously, D-Daily, W-Weekly; IC-Ion Chromatography, GFAAS-Graphite Furnace Atomic Absorption Spectrometry

## 2.4. Monitored parameters and analytical methods

In this study, the following methods were applied: electroanalytical for measurements of pH and the dissolved oxygen content, IC for the ion content (anions and cations) and optical for the measurements of iron, copper and silica. The characteristic and limiting values for the control and diagnostic parameters for the proper functioning of the WSC are listed in Table 2, together with the sensitive analytical tools which were applied for their measurements. For all electroanalytical measurements, standard procedures were applied from Standard Methods for water and waste water determination [30]. This group of parameters was measured in parallel: on-line and in the laboratory. For the determination of low levels of ionic impurities in the low ppb or even ppt (ng L<sup>-1</sup>) levels, sample preconcentration is usually required. In a previous study, an ion chromatographic method (large-loop direct injection technique) was

developed for the determination of inorganic anions at trace levels in power plant water samples [10,11]. Copper and iron ions were analysed by the GFAAS method. The detection limit was the most challenging aspect of the analysis, due to rather low concentrations of these ions in the samples. A standard additive method was applied [17].

## 2.5. Data analysis and chemometric methods

The statistical data processing was performed employing SPSS and Minitab software packages, using the logarithmically transformed trace element concentration data set. Multivariate analysis of the water quality data set was performed using PCA/FA and CA. The PCA and HCA were applied for the analysis of the distribution and spatial variations of ionic impurities in different parts of the WSC in the power plant.

Principal component analysis, as a non-supervised technique, reduces the dimensionality of the original

**Table 3.** Detection limits obtained for the five analyte anions (working range 0.1–100 µg L<sup>-1</sup>).

Anion	DL <sup>a</sup> (µg L <sup>-1</sup> )	Correlation coefficient, <i>r</i>	Linear range (µg L <sup>-1</sup> )
Fluoride <sup>(1)</sup>	0.080	0.99269	0.718–99.8
Chloride <sup>(1)</sup>	0.160	0.97295	1.16–99.4
Nitrate <sup>(1)</sup>	0.180	0.99837	0.93–94.2
Phosphate <sup>(1)</sup>	0.230	0.99817	0.90–96.3
Sulphate <sup>(1)</sup>	0.200	0.99826	0.47–94.0
Fluoride <sup>(2)</sup>	0.077	0.99992	0.094–99.8
Chloride <sup>(2)</sup>	0.082	0.99701	0.15–117.4

<sup>a</sup>DL = (S.D.) × (t<sub>0.99%</sub>)<sub>n</sub> for n = 5.

<sup>1</sup> Eluent 1: 4.5 mM Na<sub>2</sub>CO<sub>3</sub>/NaHCO<sub>3</sub>

<sup>2</sup> Eluent 2: 1.0 mM NaOH

data matrix retaining the maximum amount of variability. It allows the relationship between variables, as well as recognizing the data structure. PCA is usefully applied for assessment of water quality: surface [31–34], groundwater [35], drinking water and marine water [24–26]. PCA also has a significant role for the analysis of biomaterials and food [36–39].

CA classifies objects (cases) into classes (clusters), so that each object is similar to the others within a class but different from those in other classes with respect to a predetermined selection criterion. Hierarchical agglomerative clustering is the most common approach typically illustrated by a dendrogram. CA using the Ward method is regarded as a very efficient method and was applied to standardized data considering previous reports from the literature [21,34,36]. Many applications of CA to water quality assessment have been reported [40–42].

### 3. Results and discussion

#### 3.1. Validation of the IC method for the determination of anions and cations

The use of an IonPac AS14 column with an eluent mixture of 3.5 mM sodium carbonate and 1.0 mM sodium hydrogen carbonate was adopted as the IC method for the separation of anions. A large-volume direct injection technique was developed and applied. All the anions were usually well-resolved within 15 min. Repeatability tests under the same conditions (the same method, apparatus and laboratory), based on five injections of an anion standards consisting of F<sup>-</sup>, Cl<sup>-</sup>, NO<sub>3</sub><sup>-</sup>, PO<sub>4</sub><sup>3-</sup> and SO<sub>4</sub><sup>2-</sup> at concentrations ranging from 0.1 to 100 µg L<sup>-1</sup> were performed. The relative standard deviations (RSD) of the retention times and peak areas were less than 0.8 and 8.0 %, respectively [11].

To determine the detection limit (DL), replicate measurements (n=5) of deionized water spiked with analyte ions at concentrations ranging from 0.1 µg L<sup>-1</sup> to 100.0 µg L<sup>-1</sup> of anions were used. For each anion, the standard deviation value in concentration units (SDV) was calculated from five replicates and multiplied by the corresponding Student's *t*-value (for the 99% confidence level and for *n* – 1 degrees of freedom) to calculate the DL of the anion [3]. The DL values obtained in these IC experimental runs are reported in Table 3.

Fluoride and chloride were determined using the hydroxide eluent, because the use of Na<sub>2</sub>CO<sub>3</sub>/NaHCO<sub>3</sub> as an eluent did not provide good results in the separation of these anions. The results obtained with NaOH as an eluent are also presented in Table 3.

In order to evaluate the method performance, prepared standards were analyzed. The results show that calibration curves for target anions had good linearity. The Table 3 shows that the correlation coefficients (*r*) of the calibration curves for fluoride and chloride were 0.997 or higher. To determine the DL, replicate measurements (n=5) of deionised water spiked with analyte ions at concentrations ranging from 0.1 to 100.0 µg L<sup>-1</sup> for target anions were performed. The detection limits for target anions were 0.077 for fluoride, and 0.082 µg L<sup>-1</sup> for chloride, respectively (Table 3). The results show that the relative standard deviations of the retention times for five consecutive measurements were less than 0.3%, and the average recoveries were in the range of 60–120% [11]. All calculations were made for all concentrations of standard solutions with five replicates.

For the analysis of sodium and the other cations present at trace levels in high-purity power plant waters, a direct injection ion chromatographic method (the sample loop volume was 50 µL) was applied. The analyte ions were separated on a selective



**Table 4.** Detection limits obtained for the five analyte cations (working range 1.0–1000  $\mu\text{g L}^{-1}$ ).

Cation	DL <sup>a</sup> ( $\mu\text{g L}^{-1}$ )	Correlation coefficient, <i>r</i>	Linear range ( $\mu\text{g L}^{-1}$ )
Sodium	0.089	0,99759	1.0–1260
Ammonia	0.15	0,99803	3.4–1160
Potassium	0.011	0,99729	11.8–1070
Manganese	0.061	0,99692	0.011 –1080
Calcium	0.071	0,99692	0.90–1020

<sup>a</sup>DL = (S.D.)  $\times$  ( $t_{2,99\%}$ ) for  $n = 5$ .

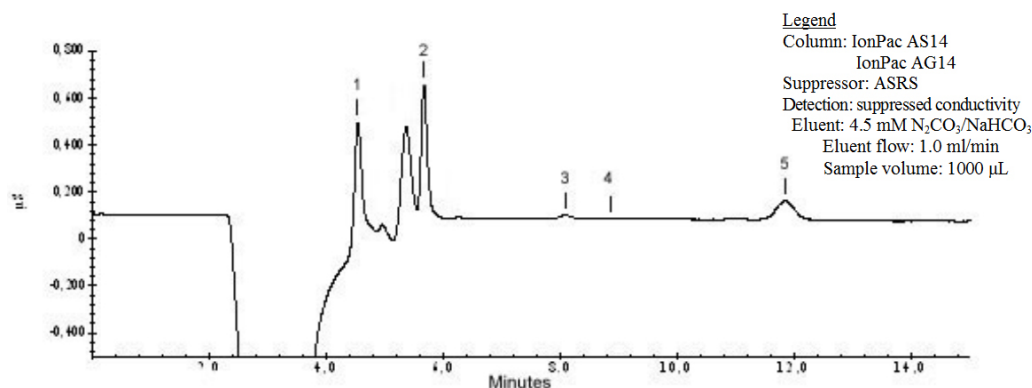

**Figure 3.** A representative chromatogram of anions corresponding to the SIC analysis of a condensed steam sample. Detected peaks: 1-fluoride, 2-chloride, 3-nitrate, 4-phosphate, 5-sulphate.

cation-exchange column (CS12A) using high-purity 20.0 mM methanesulphonic acid as the mobile phase, and detected using the suppressed conductivity detection method. The detection limits were less than 0.16  $\mu\text{g L}^{-1}$  (Table 4). Retention time precision was less than 0.5% ( $n=5$ ) for the ultra pure water samples. Recovery values were in the range of 60–130%. All calculations were made for all concentrations of standard solutions with five replicates.

### 3.2. Validation of the GF-AAS method for the determination of iron and cooper

GFAAS is a highly sensitive spectroscopic technique that provides excellent detection limits for measuring low concentrations of metals in aqueous and solid samples, and was therefore the method of choice for the analysis of copper and iron. A standard additive method was applied [17]. The *RSDs* for the target ions for five replicates ( $n=5$ ) were less than 5%. The calibration curves for Fe and Cu in the concentration range 0.5–15  $\mu\text{g L}^{-1}$  showed very good linearity (dynamic linear range 0.41–15.5 for Cu and 0.16–15.2 for Fe), the correlation factor, *r*, was 0.99924 for Fe and 0.99658 for Cu. The detection limit was calculated using the well-known “3 $\sigma$  method”. The detection limit could be calculated as three times the standard deviation of the

blank signal divided by the calibration curve slope. The values obtained of *DL* were 0.010  $\mu\text{g L}^{-1}$  for  $\text{Fe}^{2+}$ , and 0.45  $\mu\text{g L}^{-1}$  for  $\text{Cu}^{2+}$ , respectively, for the test portion.

### 3.3. Determination of trace ionic impurities in the water–steam cycle in the TPP

A series of representative samples from the thermal power plant Nikola Tesla, Serbia, were analyzed with respect to their content of ionic species. The samples were taken during different plant operation modes (normal operation phases and block movements). The ions that were analyzed to indicate the water quality were the anions:  $\text{F}^-$ ,  $\text{Cl}^-$ ,  $\text{NO}_3^-$ ,  $\text{PO}_4^{3-}$  and  $\text{SO}_4^{2-}$ , and the cations:  $\text{Na}^+$ ,  $\text{Ca}^{2+}$ ,  $\text{Mg}^{2+}$ ,  $\text{NH}_4^+$  and the metal ions:  $\text{Cu}^{2+}$ ,  $\text{Fe}^{2,3+}$ , as well as the control parameters, pH, silicate content (as  $\text{SiO}_2$ ) and dissolved  $\text{O}_2$ . One representative example of a chromatogram obtained by application of the IC procedure with carbonate/hydrogen carbonate, as an eluent, for the measurement of the major anions in condensed steam sample is presented in Fig. 3.

The potassium and phosphate peaks were near the background noise levels and were therefore reported as below the *DL*. For this reason, these ions were not included in the further multivariate analysis of the monitoring data set.

**Table 5.** Descriptive statistics of the elemental concentrations ( $\mu\text{g L}^{-1}$ ) in 33 water–steam samples.

	pH	O <sub>2</sub>	SiO <sub>2</sub>	Na <sup>+</sup>	NH <sub>4</sub> <sup>+</sup>	Mg <sup>2+</sup>	Ca <sup>2+</sup>	Fe <sup>2,3+</sup>	Cu <sup>2+</sup>	F <sup>-</sup>	Cl <sup>-</sup>	NO <sub>3</sub> <sup>-</sup>	SO <sub>4</sub> <sup>2-</sup>
<b>Mean</b>	9.44	5.10	38.15	7.66	933.01	49.97	1182.56	5.27	7.13	1.04	17.66	9.87	48.61
<b>SD</b>	0.13	0.56	35.51	12.33	786.54	55.42	1265.79	8.42	9.57	0.67	15.03	12.67	63.57
<b>Minimum</b>	9.11	4.00	4.90	0.06	192.20	0.06	91.90	0.01	0.77	0.07	2.56	0.04	0.18
<b>Maximum</b>	9.70	6.70	142.00	39.80	3142.00	200.90	4632.00	28.84	34.90	2.97	56.70	39.63	220.00

### 3.4. Multivariate analysis of the process water quality in the power plant

In order to obtain a better insight into the elemental patterns, a common chemometric approach to the data analysis was used. The arithmetic mean and standard deviation of the elemental concentrations for all samples were used to describe the central tendency and variations of the data, as given in Table 5.

In the first step of the statistic evaluation, Ryan–Joiner test (the significance level  $\alpha$  was 0.05) was preliminarily used to test the normality of concentration distribution within each element. This test revealed that the original data set deviated from normal distributions to different extents. The highest deviation was observed for dissolved oxygen, silica compounds and content of Na<sup>+</sup>, Cl<sup>-</sup> and SO<sub>4</sub><sup>2-</sup>. In contrast, the log–transformed data were normally distributed for all metals and anions. Hereupon, all data analyses were performed using log–transformed data.

#### 3.4.1. Principal component analysis / Factor analysis (PCA/FA)

In order to reveal the relations between the elements and to reduce the number of variables, the obtained monitoring data set were subjected to PCA/FA. PCA performed reductions of data matrix by transforming the data into orthogonal components that were a linear combination of the original variables. Before applying PCA modeling one should test the data matrix in order to detect outliers. Application of Grubb's test resulted in the detection of several outliers [43]. The critical value for  $\alpha = 0.05$  and  $n = 33$  was 2.95. This resulted in the detection of several outliers. The outliers detected in the original data set were *sample 22*, O<sub>2</sub>=14.00 (high), *sample 24*, SiO<sub>2</sub>=232.0 (high), *sample 33*, Cu<sup>2+</sup>=42.48 (high), F<sup>-</sup>=4.80 (high), *sample 31*, Cl<sup>-</sup>=591.8 (high) and Na<sup>+</sup>=886.9 (high), *sample 14* NO<sub>3</sub><sup>-</sup>=85.45 (high), and SO<sub>4</sub><sup>2-</sup>=3081 (high). These values were discarded from the PCA modelling. No outliers were found in the log–transformed data set. The correlation matrix of 13 elements obtained by PCA is presented in Table 6.

Significant and positive correlations were observed between Cl<sup>-</sup>, SiO<sub>2</sub>, Na<sup>+</sup>, Fe<sup>2+</sup>, Cu<sup>2+</sup>, Ca<sup>2+</sup>, Mg<sup>2+</sup> and pH ( $r=0.567$  to  $0.839$ ). These ions are responsible for water mineralization. Silica was positively correlated with Fe and Cu, and with Na and Cl indicating that these variables are derived from similar sources and have similar pathways. A high positive correlation was observed among Ca<sup>2+</sup> and Mg<sup>2+</sup> ( $0.839$ ), Na<sup>+</sup> and Cl<sup>-</sup> ( $0.765$ ), and moderately between SO<sub>4</sub><sup>2-</sup> and pH-values ( $0.439$ ). These parameters are responsible for deposits in pipes.

Decrease in pH-values increases the stability of the equilibrium reaction: NH<sub>3</sub> + H<sup>+</sup> = NH<sub>4</sub><sup>+</sup> (Ammonia is present in water as a result of inadequate dosing of hydrazine in the process of water conditioning). Low pH and increased presence of fluoride affects the growing presence of Si (which is caused by the separation of deposit). Silica and fluoride are in a good correlation because they lead to the formation and deposition of SiF<sub>4</sub> on the tubes. A good correlation was found for Fe and O<sub>2</sub>. Iron and dissolved oxygen form oxides (Fe<sub>2</sub>O<sub>3</sub>, Fe<sub>3</sub>O<sub>4</sub>) which cause corrosion.

This correlation matrix does not have many coefficients whose values are greater than 0.75, therefore the following criteria is adopted: significant correlation is considered to be the higher than 0.50 and a high (strong) correlation greater than 0.70 [21,41]. The correlations between the impurities are partly dependent on the problems in the system and operating modes, and partly on the chemical behaviour of water constituents. The water-steam cycle is a very complex system, with extreme operating conditions (high temperature and pressure). The working medium is the ultra-pure water, which contains very low concentrations of the elements, where instrumentation must be highly precise. Because they are affected simultaneously by spatial and temporal variations, the correlation coefficients should be interpreted with caution.

Before proceeding with the PCA, the suitability of the data for factor analysis and the justification for its implementation were assessed. Analysis of the correlation matrix revealed coefficient values of 0.3 and above. The



**Table 6.** The Pearson correlation matrix for the microelements in water–steam samples.

	pH	O <sub>2</sub>	SiO <sub>2</sub>	Na <sup>+</sup>	NH <sub>4</sub> <sup>+</sup>	Mg <sup>2+</sup>	Ca <sup>2+</sup>	Fe <sup>2,3+</sup>	Cu <sup>2+</sup>	F <sup>-</sup>	Cl <sup>-</sup>	NO <sub>3</sub> <sup>-</sup>	SO <sub>4</sub> <sup>2-</sup>
<b>pH</b>	1.000												
<b>O<sub>2</sub></b>	-0.027	1.000											
<b>SiO<sub>2</sub></b>	0.100	0.018	1.000										
<b>Na<sup>+</sup></b>	0.283	-0.052	0.592	1.000									
<b>NH<sub>4</sub><sup>+</sup></b>	0.364	-0.266	0.368	0.159	1.000								
<b>Mg<sup>2+</sup></b>	0.392	-0.027	0.384	0.625	0.258	1.000							
<b>Ca<sup>2+</sup></b>	0.570	-0.045	0.256	0.349	0.351	0.839	1.000						
<b>Fe<sup>2,3+</sup></b>	-0.091	0.249	0.579	0.644	0.005	0.354	0.080	1.000					
<b>Cu<sup>2+</sup></b>	-0.064	0.110	0.640	0.602	0.130	0.407	0.229	0.635	1.000				
<b>F<sup>-</sup></b>	0.048	-0.126	0.389	0.157	-0.042	0.371	0.380	0.128	0.175	1.000			
<b>Cl<sup>-</sup></b>	0.235	-0.113	0.757	0.765	0.418	0.755	0.611	0.567	0.602	0.427	1.000		
<b>NO<sub>3</sub><sup>-</sup></b>	0.370	0.063	-0.347	0.037	-0.088	0.211	0.351	-0.253	-0.285	-0.090	-0.140	1.000	
<b>SO<sub>4</sub><sup>2-</sup></b>	0.439	0.116	0.363	0.471	0.148	0.335	0.354	0.242	0.247	0.145	0.452	0.443	1.000

Kaiser–Meyer–Olkin Measure of Sampling Adequacy (KMO) value indicator was 0.625, which exceeds the recommended value of 0.6 [44]. The Bartlett test of sphericity [45] reached statistical significance  $p=0.000$  (should be  $p<0.50$ ), which indicates the suitability of the correlation matrix for factor analysis. From the shape of the scree plot, shown in Fig. 4, the number of important components that will be used in further calculations can be observed.

PCA revealed the presence of four components with characteristic values exceeding 1, explaining 37.9, 18.1, 11.4 and 8.6% of the variance. Based on the Catel criteria [46], two components will be used in further explanations of variances. This two-component solution explained a total of 56.0% of the variance, with the contribution of the first component of 37.9, and with the contribution of second component of 18.1%. Since two-component solution based on the Catel criteria explained 56% of the total variance, this criterion was rejected. Kaiser’s criterion [44] is adopted, according to which there are four main components that explain 76% of the total variance, because all the other components have eigenvalues less than 1.

Correlations and similarities between the variables can be seen in Fig. 5, which shows the loading plot of the first two components. Variables with low loadings have no significant impact on the structure of data, while the elements with high loadings have the most influence on the grouping and separation of power plant samples.

A high correlation was observed between: Na<sup>+</sup> and Cl<sup>-</sup>; Fe<sup>2+</sup>, Cu<sup>2+</sup> and SiO<sub>2</sub>; Ca<sup>2+</sup>, Mg<sup>2+</sup> and pH-values.

One of the major goals of the PCA is to reveal the factors that were significantly associated. It was expected that a high concentration of chloride would be associated with high concentrations of sodium and also that there would be a strong correlation between Fe and Cu.

In order to get a better insight into the latent structure of the data, the main component extracted correlation matrix was subjected to rotation. Varimax orthogonal rotation was applied, and the results after rotation are shown in Table 7. As can be seen, four significant factors were extracted.

The first factor explains the largest proportion of variance (37.9%). The representatives of this factor are iron, copper, silica, sodium and chlorides with high loading values, magnesium with moderate and sulphate and nitrate which have relatively low values of the loading. Except for NO<sub>3</sub><sup>-</sup>, all the elements have positive loading values in this factor. The key variables of the second factor are pH, NO<sub>3</sub><sup>-</sup>, Ca<sup>2+</sup>, Mg<sup>2+</sup> and SO<sub>4</sub><sup>2-</sup>. This factor is responsible for 18.1% of the total variance. The third factor, representing 11.4% of total variance, mainly includes F<sup>-</sup> with high loading, Ca<sup>2+</sup> and Mg<sup>2+</sup> which were moderately correlated, and also Cl<sup>-</sup> ion with positive, but medium-low loadings was present. The fourth factor consists only of NH<sub>4</sub><sup>+</sup>, pH and dissolved oxygen, all the other variables could not be considered significant

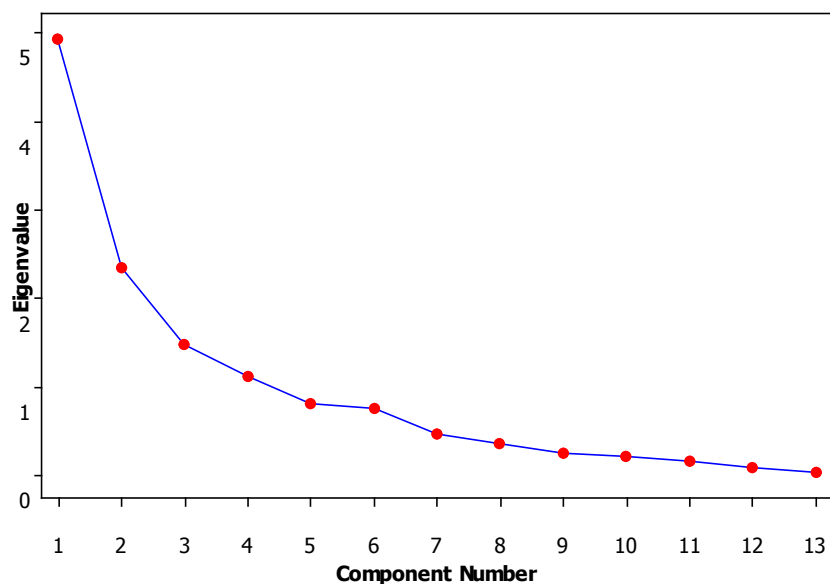

**Figure 4.** Scree plot of Eigen values of the principal components.

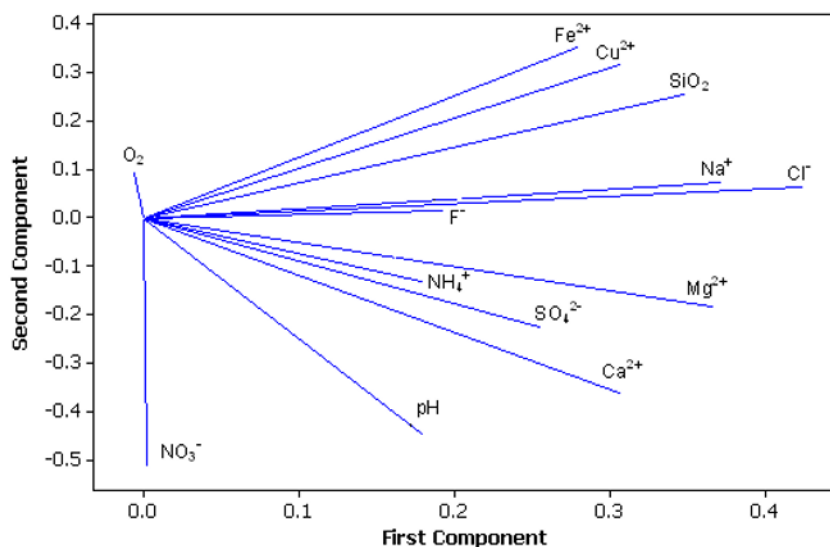

**Figure 5.** Loading plots of elements data in power plant water samples.

because they have relatively low loadings. This factor is responsible for 8.6% of the total variance. In this factor dissolved O<sub>2</sub> and NH<sub>4</sub><sup>+</sup>-ion are negatively correlated, which indicates that there is a strong influence between the matrix and trace elements (if alkaline conditions are dominant, reduced the formation of oxygen corrosion). The excess ammonia in the presence of oxygen causes corrosion of pipes made of brass and copper. The pH value of the water has to be aligned with the values for electrical conductivity and ammonia content. The optimum pH of water is in the range of 8.8 to 9.2 and it is maintained in order to avoid corrosion during plant operation.

It is obvious that some elements, such as Ca<sup>2+</sup>, Mg<sup>2+</sup> and Cl<sup>-</sup> have a high presence in more than one factor, indicating the existence of more than one significant source.

#### 3.4.2. Cluster analysis

HCA of the standardized variables using the Ward method as an amalgamation rule and the squared Euclidean distance as a measure of the proximity between the samples was performed. The obtained dendrogram presenting the clustering of the analyzed water samples is presented in Fig. 6.

**Table 7.** Varimax rotated factor loadings of the data for the elements in power plant samples.

	Component			
	PC1	PC2	PC3	PC4
pH	0.005	0.774	-0.002	0.305
O <sub>2</sub>	0.180	0.129	-0.240	-0.684
SiO <sub>2</sub>	0.829	-0.016	0.182	0.229
Na <sup>+</sup>	0.782	0.345	0.103	0.034
NH <sub>4</sub> <sup>+</sup>	0.238	0.235	-0.154	0.826
Mg <sup>2+</sup>	0.454	0.538	0.534	0.123
Ca <sup>2+</sup>	0.192	0.671	0.539	0.233
Fe <sup>2,3+</sup>	0.854	-0.053	-0.004	-0.242
Cu <sup>2+</sup>	0.837	-0.053	0.093	-0.039
F <sup>-</sup>	0.160	-0.039	0.883	-0.007
Cl <sup>-</sup>	0.779	0.269	0.395	0.285
NO <sub>3</sub> <sup>-</sup>	-0.353	0.781	0.002	-0.252
SO <sub>4</sub> <sup>2-</sup>	0.374	0.688	-0.037	-0.111

Extraction Method: Principal Component Analysis.  
Rotation Method: Varimax with Kaiser Normalization.

The dendrogram shows that all the monitoring locations can be grouped into four main clusters. Cluster I is formed by monitoring sites: 1, 7, 8, 9, 10, 11, and 2, 3, 4, 6 and corresponds to the less polluted sites. These samples are from normal operation phase. Cluster II is formed by points: 5, 15, 16, 17 and 14, 18, 19 and it corresponds to the sites with medium pollution. Cluster III is formed by locations: 12, 20, 21, 22 and 23, 24, 30, 31, 32. Cluster IV is formed by: 13, 27 and 25, 26, 28, 29, 33. Clusters III and IV corresponds to the sites with high pollution. Samples from clusters III and IV correspond to the phase of block moving and the measured concentrations of all ions were increased (especially for Ca<sup>2+</sup>, Na<sup>+</sup>, Cl<sup>-</sup>, SO<sub>4</sub><sup>2-</sup>, SiO<sub>2</sub> and NH<sub>4</sub><sup>+</sup>). The classification of these groups varies with the significance level. Cluster IV is characterized by the biggest Euclidean distance compared to other clusters (high significance of clustering).

### 3.4.3. Spatial/temporal variations in the monitoring data set depending on the TPP operation mode

Samples were collected at different time periods and different operation modes. An interesting monitoring case was found when the steam samples collected at the entrance of the turbine and at its exit were analyzed separately. An increase in the Cl<sup>-</sup> and SO<sub>4</sub><sup>2-</sup>

concentrations was observed in these samples. Such small increases could probably be attributed to the effect of steam separation in the condenser section of the thermal power plant. This separation process tends to slightly concentrate the resulting condensed steam phase at that sampling site.

Obtained results proved, that in the normal working conditions, the content of almost all ions were below the limiting values, with the exception of sulphate, which was slightly increased in the sample of the saturated steam (SS) and at the entrance to the evaporator of the boiler (IS). The concentration of calcium was increased in all the samples. The concentrations of Na<sup>+</sup> and Cl<sup>-</sup> ions were low, under 10 µg L<sup>-1</sup>, except for the sample of saturated steam [11].

In the phase of block moving, the concentrations of ionic species increased. Particularly high concentrations of Ca<sup>2+</sup>-ion were detected in all samples, while the increased content of Na<sup>+</sup>, Cl<sup>-</sup> and SO<sub>4</sub><sup>2-</sup>-ions was in the samples of condensate (C<sub>I</sub> and C<sub>II</sub>). Also, the concentrations of iron and copper were increased at the same locations.

The distribution of the iron and copper contents in the WSC with respect to dependence on the sampling location in the phase of block moving is presented in Fig. 7. Higher amounts of cations and anions in the analyzed samples indicate there is contamination of the condensate that affects the steam quality at extremely high temperatures and pressures.

The design of an optimal monitoring with marked the main control and diagnostic parameters in the water and steam in the WSC are presented in Fig. 8. Ionic species, especially ions which are indicators of corrosion, such as sodium, chloride, iron and copper, can be minimized by continuous monitoring and maintaining of their contents as low as possible. The best method for the protection of copper parts from corrosion is removal of oxygen from the system. If this cannot be achieved, the ammonia concentration needs to be lower than 0.5 mg L<sup>-1</sup>.

This suggests that the improved monitoring system must continuously monitor parameters, which directly indicates the quality of water and steam. On the basis of this research, it can be concluded how to simplify the system of chemical control in TPP Nikola Tesla.

In Fig. 8, selected parameters are especially marked (in red color). These parameters are: pH, conductivity, silica, sodium, and chloride content and they should be monitored on-line at the characteristic points in the WSC. Based on measurements of selected on-line parameters, other parameters could be also evaluated because of their high correlation with the measured

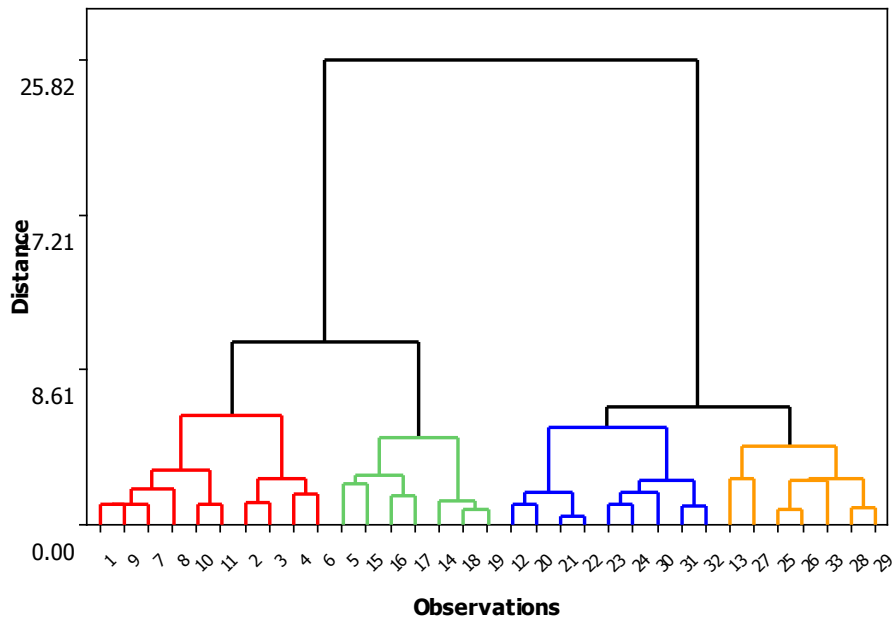

**Figure 6.** Dendrogram of the power plant water by cluster analysis based on Ward Linkage and Euclidean Distance.

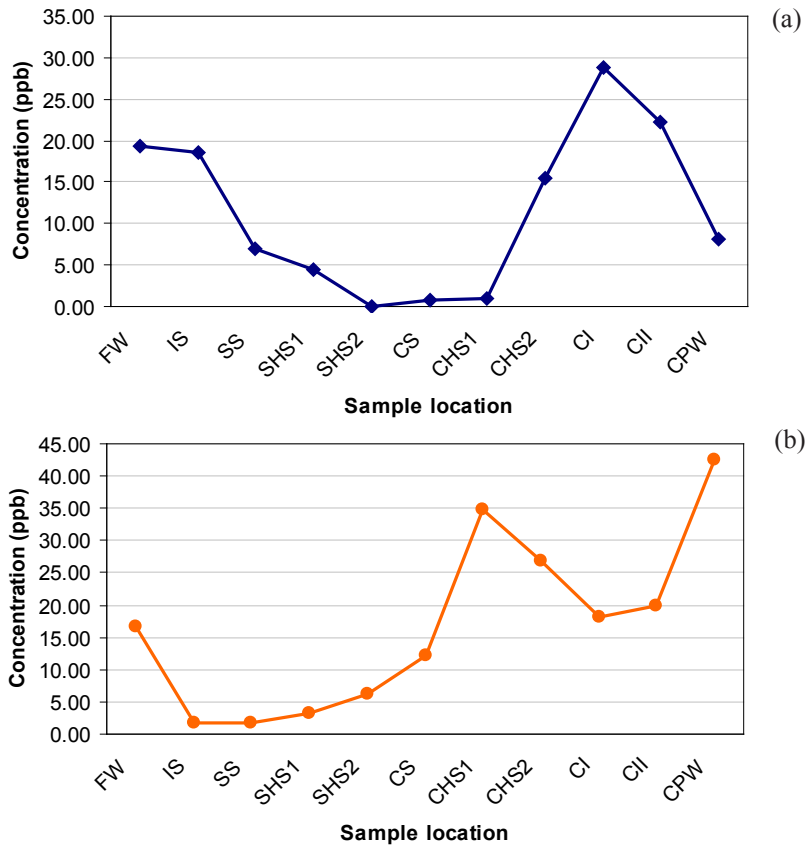

**Figure 7.** Distribution of iron and copper content depending on the sampling location and operation mode (a) Fe and (b) Cu.

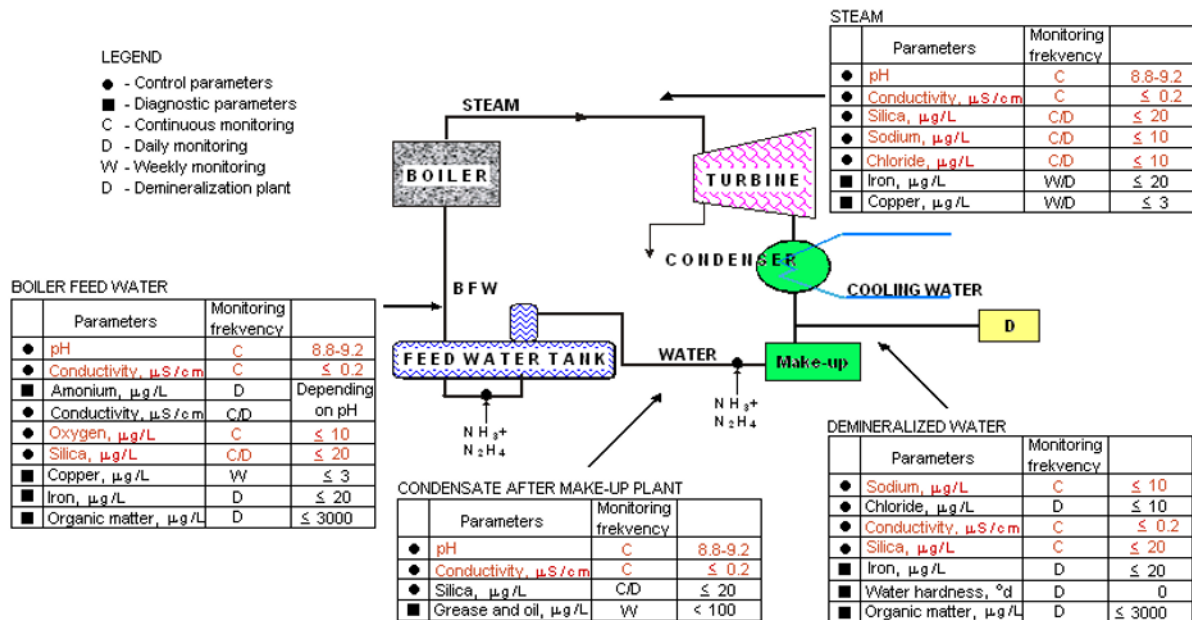

**Figure 8.** The design of an optimal monitoring with review of monitored parameters in the WSC.

parameters. In this way it is possible to obtain a complete insight into the state of the WSC with a reduced number of measured parameters that need to be controlled and with reduced frequency of their measurements.

Advantages of the continuous measurement of pH values and the other selected parameters are: fast on-line measurement and results, indication and assessment of the quality of water and steam in the water-steam cycle in power plants, the timely detection of disorders in the system and relation with other forms of impurities in the system.

In this way, the improved system of monitoring and control that includes and connects the measuring range of parameters, the frequency of measurements, the analytical methods, on-line sensors and the action levels will provide reliable operation and long life of TPP.

## 4. Conclusions

The object of this study was to analyse ionic traces in WSC systems through the concrete example of a TPP in Serbia. Ion chromatographic method and GFAAS method were developed previously and tested on real samples from the WSC.

For the first time the spatial/temporal variation of process water quality in the TPP and the distribution of ionic and other impurities (depending on working conditions and sample locations) by the use of multivariate statistical analysis were investigated. HCA, PCA and FA were applied.

PCA/FA were shown to be suitable for data reduction of parameters which can be related to the main problems concerning corrosion processes. It was concluded that only the pH,  $Na^+$ ,  $Cl^-$ ,  $SiO_2$ ,  $O_2$  are of priority importance for the explanation of the water quality variation in the WSC. In this manner, PCA/FA is convenient for extraction and identification of the factors/sources responsible for variations in water quality. PCA revealed the presence of four components with characteristic values exceeding 1, explaining 37.9, 18.1, 11.4 and 8.6% of the variance.

HCA has enabled the grouping of the samples according to the sampling location and working conditions. By this method it is possible to decrease the number of measured parameters on the measuring locations.

The idea was to design and optimize a monitoring strategy for future analysis by which the monitoring frequency could be decreased, as well as the number of sampling stations and the corresponding costs. The proposed monitoring scheme with a reduced number of parameters for continuous measurement was presented. Control positions with the selected parameters for on-line monitoring are marked, based on the results obtained by PCA / FA and CA methods.

The frequency of measurements can be reduced on the basis of on-line measured parameters when they deviate from proposed values. Because the on-line parameters are directly related to corrosion problems in the system and the operation mode, they can be taken as representatives of the four factors for on-line screening.

System monitoring can be simplified by choosing a reduced number of parameters of each factor ( $\text{SiO}_2$ ,  $\text{Na}^+$  and  $\text{Cl}^-$  for the first, pH and  $\text{Na}^+$  for second, silica for the third factor because it is strongly correlated with  $\text{F}^-$ ,  $\text{Ca}^{2+}$ ,  $\text{Mg}^{2+}$  who are representatives of this factor, and pH and dissolved  $\text{O}_2$  for the fourth factor).

## References

- [1] E. Kaiser, J. Riviello, M. Rey, J. Statler, S. Heberling, *J. Chromatogr. A* 739, 71 (1996)
- [2] H. Lu, Sh. Mou, R. Deng, J. Riviello, *Microchem. J.* 64, 1 (2000)
- [3] E. Santoyo, S.P. Verma, F. Sandoval, A. Aparicio, R. Garcia, *J. Chromatogr. A* 949, 281 (2002)
- [4] Z. Lu, Y. Liu, V. Barreto, C. Pohl, N. Avdalovic, R. Joyce, B. Newton, *J. Chromatogr. A* 956, 129 (2002)
- [5] P. Miskaki, E. Lytras, L. Kousouris, P. Tzoumerkas, *Desalination* 213, 182 (2007)
- [6] C. Lopez-Moreno, I. Viera, A.M. Urbano, *Desalination* 261, 111 (2010)
- [7] H. Huang, G.A. Sorial, *Chemosphere* 64, 1150 (2006)
- [8] R. Wang, N. Wang, M. Ye, Y. Zhu, *J. Chromatogr. A* 1265, 186 (2012)
- [9] H. Kaasalainen, A. Stefansson, *Talanta* 85, 1897 (2011)
- [10] D.Z. Čičkarić, I. Deršek-Timotić, A. Onjia, Lj. Rajaković, *J. Serb. Chem. Soc.* 70, 995 (2005)
- [11] D.Z. Živojinović, Lj.V. Rajaković, *Desalination* 275, 17 (2011)
- [12] *Pressurized Water Reactors Secondary Water Chemistry Guidelines, Revision 6 (EPRI Report 1008224), December, 2004*
- [13] V.N. Rajakovic-Ognjanovic, D.Z. Zivojinovic, B.N. Grgur, Lj.V. Rajakovic, *Appl. Therm. Eng.* 31, 119 (2011)
- [14] K.R. Cooper, R.G. Kelly, *J. Chromatogr. A* 739, 183 (1996)
- [15] D.H. Thomas, M. Rey, P.E. Jackson, *J. Chromatogr. A* 956, 181 (2002)
- [16] B. De Borja, M. Laikhtman, J. Rohrer, *J. Chromatogr. A* 995, 143 (2003)
- [17] D. Čičkarić, J. Marković, Lj. Rajaković, *Water Qual.* 2, 14 (2004)
- [18] Lj. V. Rajaković, V. Šijački-Žeravčić, P. Stefanović, et al., *Corrosion potential of water: Book 2 (Codex, Belgrade, 2002)*
- [19] Lj.V. Rajaković, J. Kerečki, *Hem. Ind.* 57, 318 (2003)
- [20] D. A. Lytle, M. N. Nadagouda, *Corros. Sci.* 52, 1927 (2010)
- [21] M. Varol, B. Gokot, A. Bekleyen, B. Sen, *Catena* 92, 11 (2012)
- [22] M. Cieszynska, M. Wesolowski, M. Bartoszewicz, M. Michalska, *Cent. Eur. J. Chem.* 9, 265 (2011)
- [23] F. Huang, X. Wang, L. Lou, Z. Zhou, J. Wu, *Water Res.* 44, 1562 (2010)
- [24] N. Ruggieri, M. Castellano, M. Capello, S. Maggi, P. Povero, *Mar. Pollut. Bull.* 62, 340 (2011)
- [25] A. Astel, M. Biziuk, A. Przyjazny, J. Namiesnik, *Water Res.* 40, 1706 (2006)
- [26] I. Stanimirova, M. Połowniak, R. Skorek, A. Kita, E. John, F. Buhl, B. Walczak, *Talanta* 74, 153 (2007)
- [27] R. Slingsby, R. Kiser, *Trends Anal. Chem.* 20, 288 (2001)
- [28] E. Gómez-Ordóñez, E. Alonso, P. Rupérez, *Talanta* 82, 1313 (2010)
- [29] W.W. Buchberger, *Trends Anal. Chem.* 20, 296 (2001)
- [30] *Standard Methods for the Examination of Water & Wastewater: Centennial Edition, 21st Edition (American Public Health Association, Washington, 2005)*
- [31] P. Raj Kannel, S. Lee, S. Raj Kanel, S. Pratap Khan, *Anal. Chim. Acta* 582, 390 (2007)
- [32] Y. Ouyang, *Water Res.* 39, 2621 (2005)
- [33] V. Simeonov, J.A. Stratis, C. Samara, G. Zachariadis, D. Voutsas, A. Anthemidis, et al., *Water Res.* 37, 4119 (2003)
- [34] T. Kowalkowski, R. Zbytniewski, J. Szpejna, B. Buszewski, *Water Res.* 40, 744 (2006)
- [35] E. Marengo M.C. Gennaro, E. Robotti, A. Maiocchi, G. Pavese, A. Indaco, A. Rainero, *Microchem. J.* 88, 167 (2008)
- [36] S. Razic, A. Onjia, S. Đogo, L. Slavkovic, A. Popovic, *Talanta* 67, 233 (2005)
- [37] B. Skrbic, A. Onjia, *Food Control* 18, 338 (2007)
- [38] K. Hron, M. Jelinkova, P. Filzmoser, R. Kreuziger, P. Bednar, P. Bartak, *Talanta* 90, 46 (2012)
- [39] A. Przybylowicz, P. Chesny, M. Herman, A. Parczewski, S. Walas, W. Piekoszewski, *Cent. Eur. J. Chem.* 10(5), 1590 (2012)
- [40] G. Ragno, M. De Luca, G. Ioele, *Microchem. J.* 87, 119 (2007)

## Acknowledgments

Support from the Research Fund of Serbia is gratefully acknowledged, Project No. III 43009 and TR 37010. The authors thank the TPP "Nikola Tesla" in Obrenovac for the samples from water-steam cycle used in this study.



- [41] S. Shrestha, F. Kazama, *Environ. Modell. Softw* 22, 464 (2007)
- [42] P.M.S.M. Rodrigues, R. M.M. Rodrigues, B.H.F. Costa, A.A.L. Tavares Martins, J.C.G. Esteves da Silva, *Chemometr Intell Lab.* 102, 130 (2010)
- [43] F. Grubbs, *Technometrics* 11(1), 1 (1969)
- [44] H. Kaiser, *Educ. Psychol. Meas.* 20, 141 (1960)
- [45] M.S. Bartlett, *Journal off the Royal Statistical Society* 16 (Series B), 296 (1954)
- [46] B.F.J. Manly, *Multivariate Statistical Methods: A Primer*, 3rd edition (Chapman and Hall/CRC, New York, 2005) 75-90