

*Powering Accra: Projecting Electricity Demand for Ghana's Capital City*

**Dissertation**

zur

Erlangung des Doktorgrades (Dr. rer. nat.)

der

Mathematisch-Naturwissenschaftlichen Fakultät

der

Rheinischen Friedrich-Wilhelms-Universität Bonn

vorgelegt von

*Tyler James Frazier*

aus

97th General United States Army Hospital  
Frankfurt am Main, Hessen, Germany

Bonn 2010

Angefertigt mit Genehmigung der Mathematisch-Naturwissenschaftlichen Fakultät der Rheinischen Friedrich-Wilhelms-Universität Bonn

1. Referent: Professor Dr. Paul L.G. Vlek
2. Referent: Professor Dr. Eckart Ehlers

Tag der Promotion:



This work is dedicated to my daughter Adriana Wafari Frazier.

*Now faith is the substance of things hoped for, the evidence of things not seen.*

Hebrews 11:1, King James Bible

## **ABSTRACT**

The purpose of this research was to create an agent-based urban simulation based on land use at the plot level for projecting the disaggregated electricity demand of the Greater Accra Metropolitan Area (GAMA). A simulation system comprised of location choice, regression, and simple models were used to project household, employment and land development decisions. Households, persons, and jobs tables were synthetically generated from GLSS5 (Ghana Living Standards Survey 2005) data using Stata, built in a MySQL database and incorporated for use in the Open Platform for Urban Simulation (OPUS). Electricity demand was projected for each of the simulation years based on a regression model. Numerous geospatial datasets were projected and edited in ArcGIS which describe the physical composition of Accra in its totality, including buildings, roads and electricity infrastructure. Household mobility was estimated from a modified Cox Regression of residential mobility in Accra (Bertrand et al.) and applied to the GLSS5 for use in the location choice model, while employment coefficients and parameters describing land value were derived from literature (Buckley et al.). The model has been applied for projecting the electricity demand of the Korle Bu district in terms of high, medium and low economic and population growth rates for the time period 2006 until 2025, based on monthly electricity consumption per meter. An additional phase of this research envisions including all 12 GAMA districts (using data which has been obtained); infrastructure models to project demand for transportation, water & sewer, and solid waste facilities; as well as comparing weak and strong sustainability scenarios with the business-as-usual development path for cost-benefit analysis of proposed public policies.

## TABLE OF CONTENTS

1.	Urban Studies and Electricity Use Planning in the Developing World	
1.1	Development Research and the City.....	7
1.2	Electricity Use and African Cities.....	11
1.3	The Remarkable Growth of Ghana’s Capital City.....	14
1.4	Research Objective.....	17
2.	Modeling the City	
2.1	The Science of the City.....	19
2.2	Platforms for Modeling Cities.....	22
2.3	Modeling Electricity Infrastructure.....	26
3.	The Physical and Human Geographic Patterns of Accra	
3.1	An Introduction to Accra.....	34
3.2	Greater Accra’s Physical Geographic Patterns.....	35
3.3	Greater Accra’s Human Geographic Patterns.....	46
4.	Electricity Infrastructure and Demand in Accra	
4.1	Powering Megacities in the Developing World.....	57
4.2	Electricity Supply in Ghana.....	58
4.3	Electricity Demand in Accra.....	62
5.	The Greater Accra Urban Simulation - Korle Bu District	
5.1	Urban Simulation System Described.....	71
5.2	Datasets.....	75
5.3	Models.....	80
5.4	Electricity Demand Projections.....	89
	Conclusion.....	95
	Appendix.....	97

# **Powering Accra: Projecting Electricity Demand for Ghana's Capital City**

# **Chapter 1**

## **Urban Studies and Electricity Use Planning in the Developing World**

## 1.1 Development Research and the City

Sir Hans Wolfgang Singer first identified one of the fundamental tenets of development research when he identified that the terms of trade between primary products and manufactured goods tend to deteriorate over time. The Singer thesis states, when resource flows from a periphery of poor and underdeveloped states to a core of wealthy states, the later will be enriched at the expense of the former. This occurs because as incomes rise, the demand for manufactured goods increases more rapidly than demand for primary products, and thus implying that it is the very structure of the market which is responsible for the existence of inequality in the world system. From this thesis emerged the concept that wealthy nations have a certain moral obligation to assist with the development of poorer nations, such that poverty is reduced, self sufficiency is promoted, and in the future, an industrialized economy will develop. It is this idea that has served as the basis for United Nations and World Bank programs, such as the International Development Association, the United Nations Development Program, and the World Food Program. It is also one of the fundamental tenets of the *Zentrum für Entwicklungsforschung* (ZEF) as well as the *Globaler Wandel des Wasserkreislaufes* (GLOWA), the institute and project hosting this doctoral work. (Singer, 1950)

In the post World War II era, development research has generally focused on poverty reduction, predominantly in the more rural, agricultural parts of developing countries, since impoverished households have been predominantly located within rural areas. Agricultural economists, hydrologic engineers, and social scientists have served to improve the lives of thousands of poor, rural households through managing water use for equitable allocation, promoting best management practices for agricultural and forest land uses, developing a better understanding of the causes of child mortality, as well as focusing on issues global phenomenon such as the dynamics of rural to urban migration and the impact HIV-AIDS, malaria, and famine have had on the Sub-Saharan. While these issues have not diminished in their importance, over the past 10 years a new, dramatic trend has begun to emerge across the landscape of the Sub-Saharan. Urbanization is reshaping the face of Africa and is demanding that urban and regional planning be incorporated as an integral part of the development research agenda.

### 1.1.1 Africa's Urbanization

The urbanization of Sub-Saharan Africa is occurring more rapidly than in any other region in the world, at a historically unprecedented absolute rate of increase. The current growth rate of almost 5 percent per year implies close to a doubling of the urban population in 15 years, with new urban residents projected to rise sharply by over 300 million between 2000 and 2030, more than twice the rural population increment (Figure 1). This implies that much of the new demand for jobs and services, as well as the supply of human energy to meet the countries' future needs, will appear in urban areas. (Kessides, 2006)

The demographic picture of Africa is one of change with the urban demographic growth coming from three sources: natural increase among existing urban residents, reclassification of formerly rural areas as urban, and internal rural-urban migration. The underlying dynamic of high urban growth rates are predominantly driven by natural increase, due to persistently high fertility rates and slowly declining mortality. Suburban land use reclassification and migration, together account for less than half (about 40%) of urban growth estimates. Furthermore, it is also necessary to explain rural-to-urban migration by "pull" factors, economic opportunities that attract residents to a city, and "push" factors, the lack of opportunities in rural areas. It is also significant to note that the traditional view of one-way rural-to-urban migration is much less important in overall population mobility than circular and seasonal migrations. And finally, perhaps the most important point regarding Africa's rapid and dramatic demographic change is that the real surge in urbanization is yet to come, with most of this growth

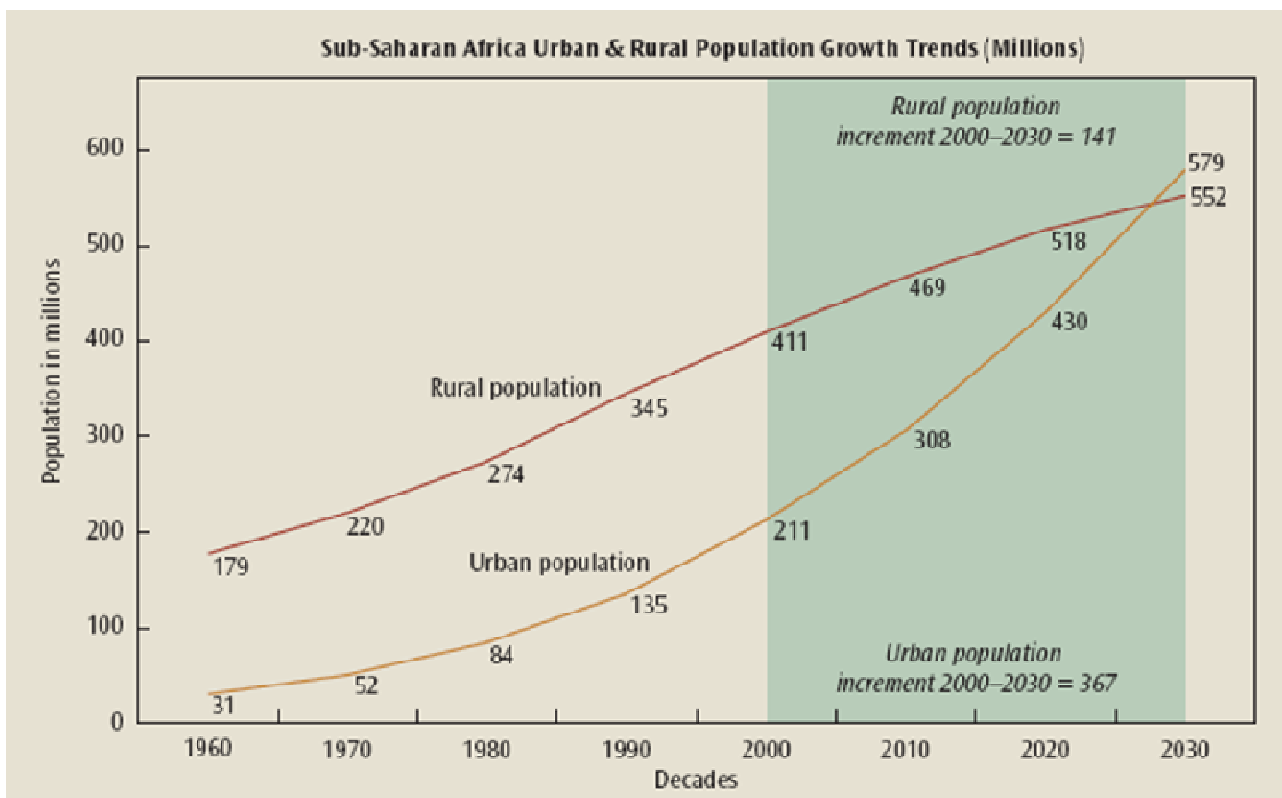

Figure 1.1 Sub-Saharan Africa Urban and Rural Population Growth (UN – World Urbanization Prospects, 2003)

expected from natural increase and rural-to-urban land use reclassification in the urban periphery. (Mabogunje, 2005)

Across all countries over time, the level of urbanization is strongly correlated to the level of economic development. In Sub-Saharan Africa this correlation is evident when comparing the levels of urbanization and of constant GDP per capita over the last decade (1990 to 2003), and is important to recognize because the economic growth that has taken place in recent years is on the whole mainly urban based. The industrial and services sectors, which roughly approximate urban based activities, accounted for at least 60 percent, and averaged almost 80 percent, of GDP growth in the region between 1990 and 2003. Additionally, the informal economy which cuts across all sectors and is predominantly urban based, has been estimated to contribute as much as 1/3rd of the total GDP in some African nations (Cameroon). Furthermore, the informal economy workforce is estimated to account for 78 percent of nonagricultural employment, 93 percent of all new jobs created and 61 percent of urban employment. Despite the strong performance of the urban based sector, for most of Africa the growth of total GDP in per capita terms has been insufficient to turn around poverty (Figure 2). If Sub-Saharan Africa is to meet the MDG of reducing poverty to 22 percent by 2015, the real GDP of African countries will need to grow by at least 6 percent per year (or slightly less if inequality improves). Policies that promote economic development through improved city planning and capital improvements will be required to enable the growth necessary in the industrial and services sectors to meet these MDG goals. (Baker, 2008)

An almost universal finding in developing countries is that rural poverty rates exceed urban poverty rates often by a very large margin, but in Sub-Saharan Africa figures show the difference between rural and urban poverty rates are actually quite close, and this gap is projected to close. Assuming no change in rural and urban poverty incidence, in twenty years half or more of the poor would reside in urban centers. Also, assessing the nature of urban poverty requires looking beyond monetary measures. Often the urban poor suffer from food insufficiency due to affordability, and while the location affords proximity to social

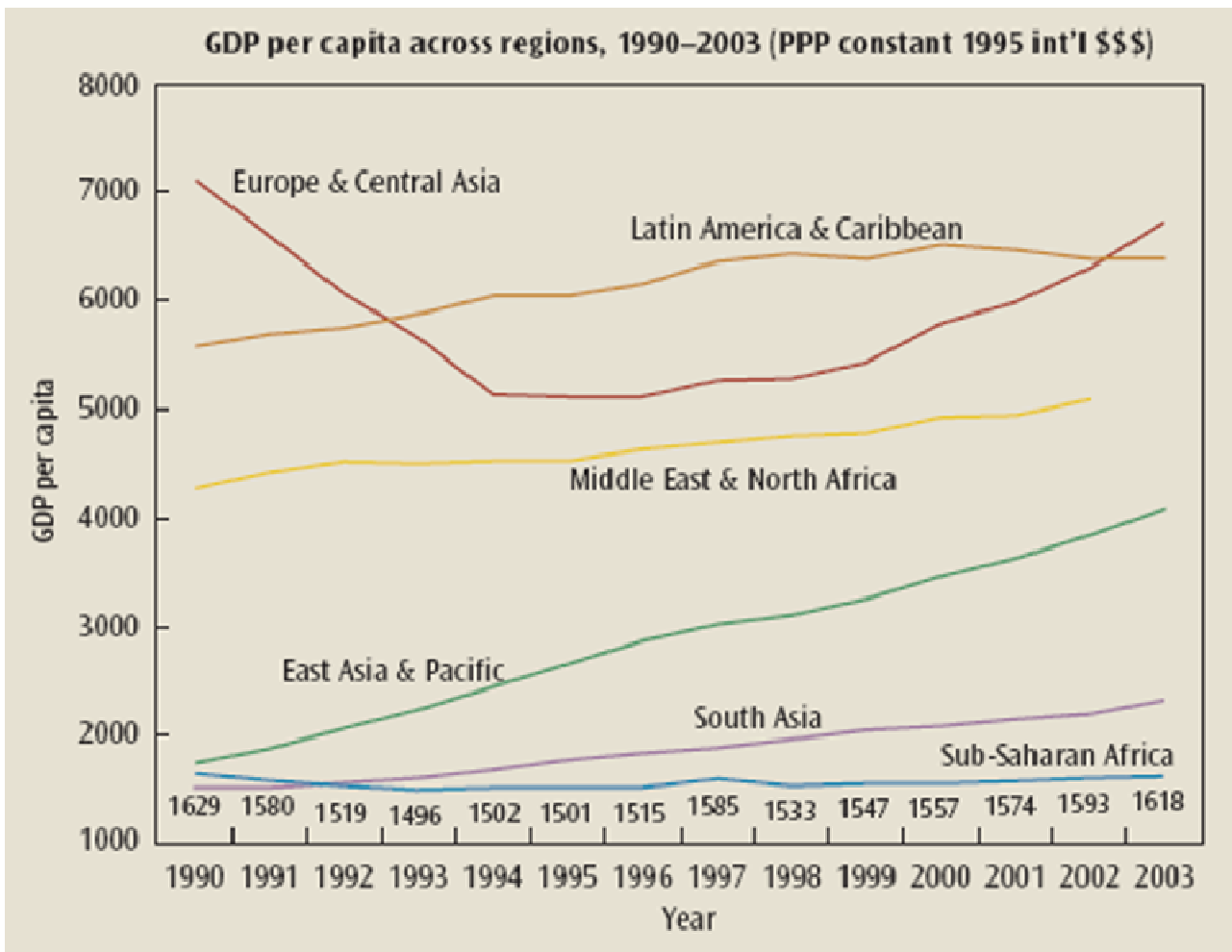

Figure 1.2 Real Per Capita Income in Sub-Saharan Africa has not Improved (GDF & WDI, 2004)

and infrastructure services it does not guarantee actual access or affordability. Physical infrastructures such as electricity, water and sewer, and transportation improvement are often extended to more remote and scattered but better-off neighborhoods while neighborhoods where the urban non-poor, which are more often even adjacent to existing infrastructures, are ignored. It's also difficult to quantify non-monetary costs for activities such as obtaining water or using sanitary facilities which may be in direct physically proximity to a household, but difficult to access due to the sheer numbers of people depending on them. Consequently, the UN-Habitat estimates that over 70 percent of the urban population suffers shelter deprivation in terms of inadequate housing, water supply, or sanitation helps to explain why the MDG target of reducing infant mortality is projected to not be met in the urban areas of most African counties. Such instances of inequitable infrastructure and social service planning are evidence that much of the deprivation in cities relates to institutional failures that perpetuate social exclusion between the urban poor and urban non-poor. Correcting intra-urban inequalities is good value since the urban slums and peri-urban residents form the core or the urban workforce and it is cost effective to ensure their effective access to basic services. (Kessides, 2006)

Cities financial performance, and therefore also their performance in service delivery, depends in the first instance on the intergovernmental fiscal framework that determines their authority to tax and their access to various forms of central revenues. While in the European Community local public expenditure averages 11 percent of GDP, in only a few African countries it amounts to 5% of GDP, and much more often is closer to 1%. The tax and borrowing authority for the cities, especially large cities and localities facing rapid population growth, rely less on taxation and more on transfers, and they are typically not



adapted to their greater expenditure and service delivery obligations. Local administrations have weak fiscal and administrative means, and are barely up to the task of maintaining services, let alone meeting the demands of growth. The result is public services are almost non-existent outside the wealthy neighborhoods and in many African cities firms and households subsist by their own grit. (Kwapong, 2008)

### **1.1.2 Urban Planning and African Cities**

Good urban management feeds into the entire national growth and welfare agenda, stimulating agricultural intensification and diversification of rural income, poverty reduction, good governance, and fiscal resource mobilization. Options for intensified agriculture and diversification into nonfarm production prove to be complimentary; they can also be fostered by common conditions, especially by effective access to major urban markets. The most constructive way of looking at the productive interlinkages among urban and rural areas may be as a virtuous circle, whereby access to urban markets and services for nonfarm production stimulates agricultural productivity and rural incomes, which in turn generate demand and labor supply for more such goods and services. (Kessides, 2006)

Urban areas epitomize the process of endogenous growth, whereby resources are used more productively and in new ways. Releasing the potential of Africa's cities by addressing basic weaknesses in land markets, public transport, and the provision of urban services could reduce an effective "binding constraint" to future growth in Africa. These benefits do not arise from the mere physical concentration of people and firms but from the ability of cities, and in particular their governments, to create an environment in which economic agents can easily interact, labor is mobile, urban land can become available for productive uses, and both citizens and firms trust they can safely invest in the future. Failure to ensure these ingredients of leads to ineffective cities and very high opportunity costs, both by lowering returns to urban assets and by provoking negative outcomes such as environmental degradation and social distress. (Mabogunje, 2005)

There are many advantages to meeting poverty reduction in urban areas. For example, the per capita costs of many forms of infrastructure and social services are generally lower, as many more people can be reached. Additional benefits can be a result of access to income from nonfarm and urban-based activities is associated with reduced rural poverty, and options for such income multiply in proximity to urban markets. Remittances represent such an important supplement to household incomes, not only from abroad, but also from the city to rural areas. Interestingly, remittances are likely to exceed microcredit or development assistance as a supplemental resource for many households. Also, improved transportation which enable migration or mobility is clearly a favorable element in income growth and poverty reduction, for both urban and rural populations. Policies should enable labor mobility as an element of general welfare and poverty reduction strategies. At the same time, migration can pose major challenges to the receiving areas by adding to near-term demands for services, raising the stakes for good urban management. (Baker, 2008)

African cities need to improve their basic flexibility of the markets, including reducing barriers for workers to obtain jobs, improving residential mobility and decreasing limitations on land use. There is large demand to make local public services more efficient, both those that can be produced through public-private partnerships and those that are pure local public goods. Also, by improving trust and confidence in government, the private sector and households won't be deterred from investing and partnering for the future, which alleviates some of the burdens borne by the public sector. Much greater benefits could be mobilized for the country and for urban inhabitants by focusing on basic investment and on efficient functioning of the essential core of land and housing, environmental services, public transportation, and

local finance. (Kessides, 2006)

In Africa, the housing sector is overwhelmingly informal, but with the right policies and institutions it could become a powerful engine for growth of jobs and for deepening the financial system. And while African governments dominate the ownership and use of urban lands, they fail to protect rights-of-way or to prevent sensitive areas from being settled. Poor regulation leads to low density, urban sprawl, which further increases the cost of public services. The health and well-being especially of the poor, but also the middle class are put at risk from the lack of and poor quality of urban environmental public goods and services, most notably water and sanitation, solid waste disposal, drainage and preservation of green space. Failures in urban transport policy seriously compromise the movement of individuals as well as the circulation of goods, again shuttering the urban marketplace. Road traffic is barely managed and roads are highly unsafe for cars and pedestrians.

### **1.1.3 The Cost of Neglect**

The failure to satisfy the basic conditions for effective cities will, in simplest terms, dilute the benefits that could be gained for the country. Neglecting African cities makes both firms and households more vulnerable to the diseconomies of urban agglomeration, which are observed in terms of: high costs of land; congestion and inadequate mobility; a polluted environment; and many other threats to social order, public health and public safety. Such risks are never entirely unavoidable within population concentrations, but they become greater and are prematurely imposed by very inadequate urban management. It is not credible to argue that diseconomies are outweighing the positive benefits of African cities, when these cities have virtually no working public transport or safe waste disposal, much of the land is held in public control with little available to meet market demand or the requirements that advance the public good, and infant mortality is rising due to poor public sanitation in the neighborhoods where most people live and work. (Kessides, 2006)

Unreliable infrastructure and high transaction costs undermine firms domestically, and this comparative disadvantage can be fatal for exporting firms attempting to participate in global markets. Urban poor children are found to be less healthy than their rural counterparts. Children in slums of Nairobi face enormously higher risks than do their peers living elsewhere in the same cities or rural settlements. The Ghana Statistical Service found that worsening indicators for urban poor, including underweight status, as relative to the rural poor.

Political preference is often given to reducing the relative dominance of the largest (primate) city and to promoting distribution of urban population and economic activity across a number of geographically dispersed, smaller cities. This approach inhibits optimal growth since large cities tend to be the most productive and the most attractive to innovative and information intensive economic activities. Urban policy should establish conditions and incentives that help existing local governments to mobilize revenues and to respond to the evolving demands for effective public services. Municipal development should be at the center of urban policy. Municipal management requires that local investment be on-budget and part of an expenditure plan, rather than undertaken through ad-hoc assistance arrangements. (Kessides, 2006)

## **1.2 Electricity Use and African Cities**

The International Energy Agency (IEA) predicts that worldwide energy consumption in the year 2030 will be about 60% higher than it was in 2002. Approximately 85% of the future power supply will still be based on fossil fuels, the burning of which represents the most important driving force for climate change. Cities are important arenas for energy use and production, and while urban areas occupy only 2% of the earth's

land surface, they are responsible for three-quarters of global energy consumption as well as approximately 85% of the global production of greenhouse gases. By 2030, 4.9 billion people, or 60% of the world's population, will inhabit cities, and the people living in these cities will consume 73% of the world's energy. In 20 years, cities will emit 73% of the world's greenhouse gases. (NKGCF 2008)

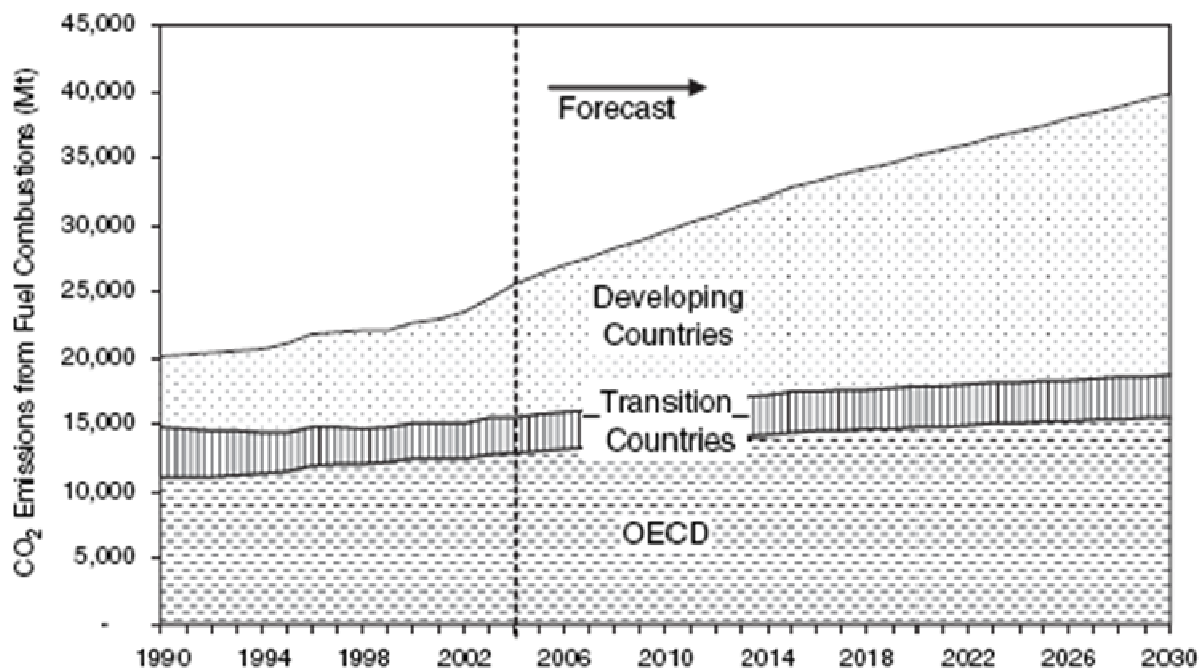

Figure 1.3 Historical and Forecasted CO<sub>2</sub> Emissions from Fuel Combustion by Region (IEA 2007)

Cities in the developing world are a particular concern, because 81% of urban energy growth will come from developing countries with their urban built up areas tripling in size. Developing countries will surpass OECD countries as the largest contributors of green house gas (GHGs) emissions by 2012, with their urban energy sectors being the primary force responsible for this dramatic increase. Within the urban energy sectors of developing countries, buildings and industries as well as energy supply and transportation present the highest potential for GHG reduction. (ESMAP 2009; The World Bank 2008; ESMAP 2007)

Cities offer strategic starting points for energy efficiency and climate protection. On the one hand, the concentration of people, material flows and residential districts makes it possible to reduce the consumption of resources because modern governance, planning and service concepts mean that more people can be supplied more economically using the same amount of transport, energy and space. Such gains in efficiency can flow into the surrounding suburban and rural areas, as well as into the national economy, to which large cities are integrated by means of resource flows and supply corridors. Also, the functional integration of urban industries, infrastructures and networks make the accelerated dissemination of innovations possible, not at least in the energy sector. An integrated approach to urban development is required which takes into account the overlapping fields of responsibility such as buildings, transportation networks, energy technologies, and citizen behavior, and integrates these into a long range planning approach.

### 1.2.1 Electricity Use and Poverty Reduction

Numerous studies have been conducted recently to determine the causalities between electricity consumption and gross domestic product or average annual income in developing countries. Narayan and

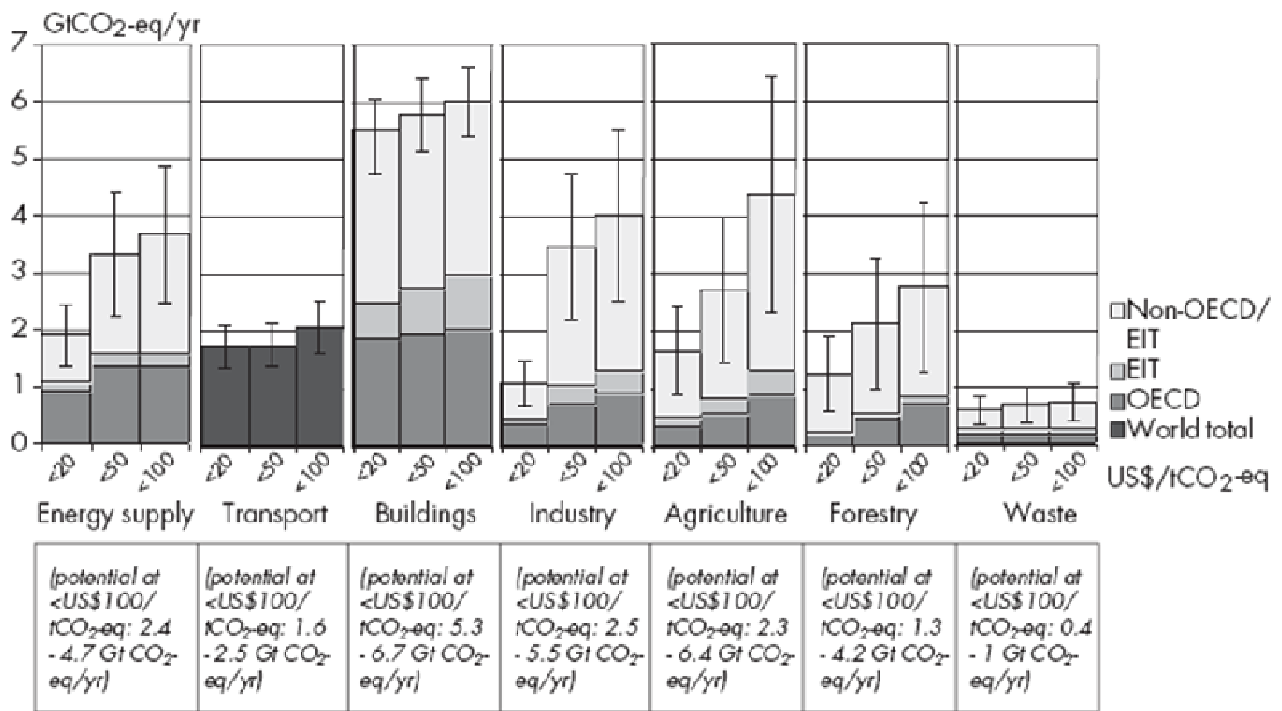

Figure 1.4 GHG Mitigation Measures Projected to 2030 (IPCC 2007)

Smith examined the causal relationship between electricity consumption and gross domestic product in a number of Middle East countries, finding that a 1 percent increase in electricity consumption increases GDP by 0.04%. Chen, Kuo, and Chen conducted a similar study investigating the relationship between GDP and electricity consumption in 10 developing countries in Asia and likewise found that sufficiently large supply of electricity can ensure a higher level of economic growth. Lee conducted a study of developing countries and found long-run and short-run causalities from energy consumption to GDP, while Akinlo conducted a similar study in Sub-Saharan Africa and likewise found that energy consumption has a significant positive long run impact on economic growth in Ghana, Gambia, and Senegal among other African countries. (Narayan & Smith 2009; Chen, Kuo, & Chen 2007; Lee 2005; Akinlo 2008)

While these studies clearly state the positive causality between electricity consumption, GDP, and average annual income, in more practical terms, the availability of electricity in urban areas is part of an enabling environment that promotes economic development and quality of life. The availability of electricity is not a panacea to cure all the ills of poverty, but availability of modern electricity services will make commercial businesses more profitable, residential households more enjoyable, industries more productive, and institutions more effective. Furthermore, electricity supply is part of a virtuous cycle that not only supports increases in the average annual incomes, but is also important in transportation networks for traffic control and street lighting, in water and sewer networks for maintaining pressure and preventing backflows, as well as with hospital, schools, and public safety.

### 1.2.2 Urban Planning and Electricity Demand

Energy demand forecasting is an essential component of energy planning and formulating strategies and recommending policies. The task is not only developing countries where necessary data, appropriate models and required institutions are lacking, but also in industrialized countries in which these limitations are somewhat less serious. Most demand modeling focuses on econometric, end use, or hybrid approaches. The econometric approach establishes a relationship between the dependent variable and certain chosen independent variables by statistical analysis for historical data. The relationship so determined can then be used for forecasting simply by considering changes in the independent variables

and determining their effect on the dependent variable. The discrete choice method and multinomial-logit model represent recent break-throughs in this type of approach. The end-use approach is more of a bottom-up approach which disaggregates energy demand in accordance with the individual land use (industrial, commercial, institutional, residential, transportation) and projects energy demand in accordance with those available, disaggregated end-uses and then summarizes the total derived demand. (Bhattacharyya, 2009)

### 1.3 The Remarkable Growth of Ghana's Capital City

Global experiences illustrate that as economies grow, rapid urbanization takes place that encompass a large share of a nation's population. In step with its Sub-Saharan location, Ghana is also experiencing unprecedented urbanization with approximately 50 percent of its more than 20 million people currently living in urban areas with this share expected to be 65% by 2030. The most significant growth is taking place in Accra, which is Ghana's administrative and commercial center, as well as its largest and fastest growing urban concentration. Inhabited by more than 3 million people, representing 15 percent of the total population and 40% of the total urban population, Accra's growth rate of 4% per year implies that the population will double in 16 years. But these projected increases are not a new trend, instead they are an extension of the past 15 years when Accra also doubled its population and expanded its area almost three fold. Between 1990 and 2005 the built up area increased from 133 square kilometers to 344 square kilometers, and the population density decreased from 14,000 persons per square kilometer to 8,000. (United Nations, 2005; World Bank, 2007; World Bank, 2009)

The urbanization pattern of Accra reveals strong physical growth, which is typified by moderate and patchy densification within the inner core, involving the replacement of residential by commercial uses, and uncontrolled and low density peripheral growth. This urban sprawl is expanding the boundaries of Accra and a key issue that emerges is the efficient delivery of infrastructure and services. Lack of comprehensive urban development policies and inadequate implementation of programs on urban management, land use, transport and economic development is permitting unbridled urban sprawl, which not only limits the growth potential of all sectors but also has a particularly significant affect on the most vulnerable sections of society due to their dependence on public systems. (World Bank 2007; World Bank 2008; Mabogunje, 2005)

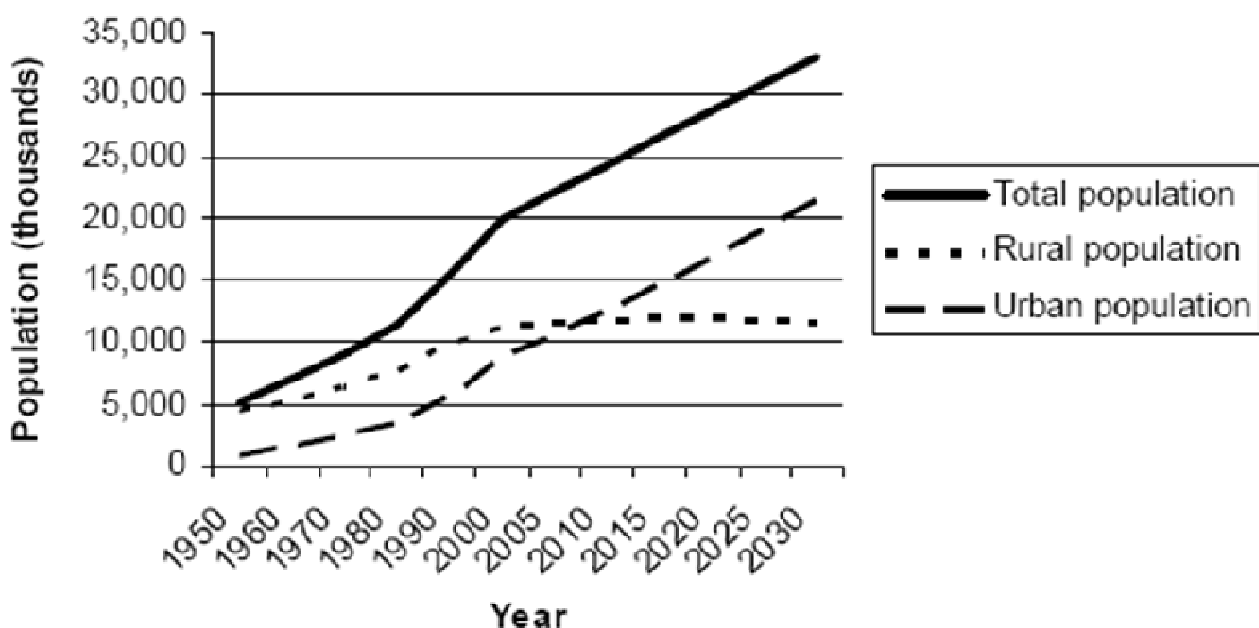

Figure 1.5 Ghana Urban and Rural Population Growth (UN – World Urbanization Prospects, 2005)



Without a clear policy direction and vision, the ability of cities to grow competitively and remain bankable and livable is often compromised. Like most Sub-Saharan countries, the growth of the agriculture sector in Ghana is slowing down and “push factors” are causing migration to towns and cities. However, the urban areas are not generating enough economic growth for the increased population and local authorities do not have sufficient resources or expertise to make comprehensive provisions for public services, such as electricity, water, transportation, education, health care, and public safety. While a contraction of the agricultural sector has served to encourage rural to urban migration, natural increases due to high fertility and greatly reduced child mortality rates in urban areas as well as the reclassification of rural areas to urban lands are the primary explanations for the growth of Ghanaian cities.

There is a strong need for Government commitment to address the emerging issues of the urban sector. It is clear that urbanization is here to stay and that it needs to be tackled strategically within the context of economic development and poverty reduction. There is a pervasive inertia which has prevented the Government of Ghana from effectively and decisively tackling the decentralization agenda and the subsequent service delivery and financing of local investments. Ghana needs to move away from “business as usual” and move towards sustainable solutions that link municipal management reforms to improved access to services and economic growth, providing operational tools for future planning, improving transfers and local taxation and creating an environment favorable to business and economic activities. (The World Bank, 2008)

Land management remains a key constraint for effective growth in Greater Accra. The dual system of land delivery, traditional and public, and the lack of systematic planning at the local level have created a complicated system of property rights. Existing revenue mechanisms like property tax rates add minimal value to the local government own-source revenues. Furthermore, the poor have very limited access to decent shelter and are often forced to live in slums or overcrowded tenements. The rapid demand for

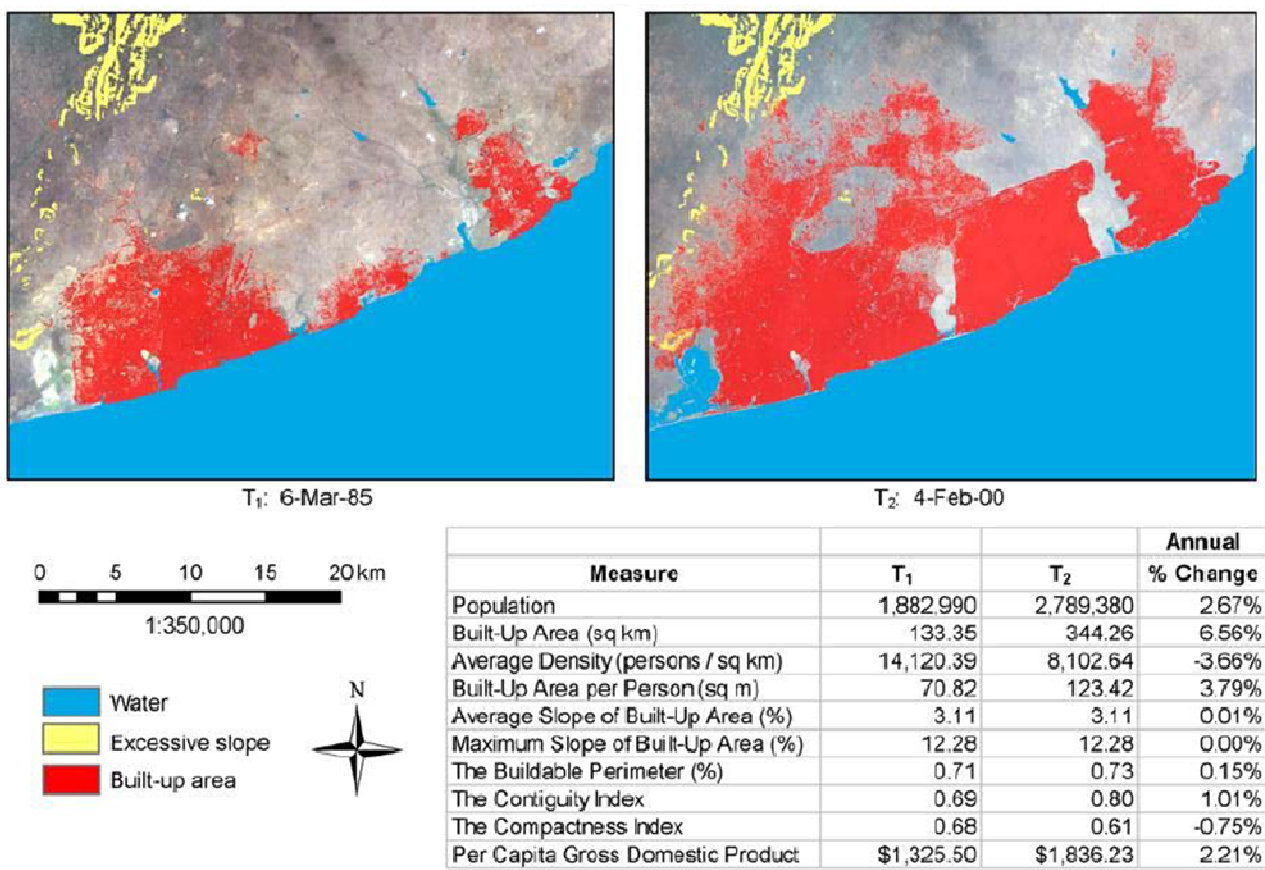

Figure 1.6 Urban Sprawl of Accra, Ghana from 1985 until 2000 (Buckley, 2005)

land in Accra has significantly increased land values in the central business districts, so that they are now comparable to some European Cities. But, lack of property rights is having an impact on business development, and within the decentralized context, it is evident that the District Assembly does not have enough authority and resources to effectively address land management activities. (The World Bank, 2008)

The decentralization agenda has taken a long time to take off in Ghana. Practical arrangements for sharing of duties and responsibilities between the DAs of Greater Accra and the Government remain to be defined and delivery of services to the population is hampered by a number of factors. Functional overlap between deconcentrated administration and DAs, use of secondment of deconcentrated staff to DAs, leaving DAs little influence on personnel matters and training, and transfers making up 84 percent of DA revenues (which leave little incentive for savings), are all structural problems. Additional issues are, the fact that District Assemblies generate only modest amounts of internal revenues, that DAs budgets are not linked to investment plans, and that transfer systems favor small DAs, while capital expenditures in Greater Accra are approximately \$2.7 USD per capita as compared to an estimated need of \$80 USD per capita. (The World Bank, 2008)

This results in a situation where the larger DAs of Greater Accra are not able to provide services to their populations. Due to inadequate financing and management capacity, water coverage has declined in urban areas from 85 percent in 1990 to 61% in 2004. Solid waste management presents a huge expense on the DAs budgets but is still not functioning, with only 70 percent being collected. Transportation networks have failing levels of service across the metropolitan area and safety standards woefully substandard. The electricity sector is strained, which could result in reduction of GDP by as much as 0.9 percent per year. (The World Bank, 2008)

With respect to investment climate issues, firms in urban areas are constrained by a number of challenges, including the cost (in terms of fees and procedures) of starting a business anywhere in Ghana, registering a commercial property, enforcing a contract, going through bankruptcy and trading across borders. Small and micro enterprises are severely constrained by lack of access to credit. Additionally, inadequate infrastructure facilities and public services hinder the formation and growth of firms by increasing the cost of doing business, limiting access to markets, and reducing efficiency. A vibrant urban agglomeration with improved connectivity and productivity can help bridge the gap with the rural areas like trade, services, and employment. (The World Bank, 2008)

Perhaps the most important factor in the modernization of Ghana is the presence of modern electricity systems in its urban centers. Of all the western world's appurtenances, none has a more profound potential to improve quality of life standards than a modern electricity infrastructure. The presence of electricity facilities supports all public infrastructures, from transportation systems to potable water and sanitary sewer services, from medical and public education to police, fire, and telecommunications. A reliable electricity supply is critical to the realization of a modern Ghana. (National Development Planning Commission of Ghana, 2005; United Nations, 2006)

Accra, Ghana is on the verge of becoming a megacity and thus facing critical decisions on which direction to take in the future. While its continued expansion could further fuel energy consumption demands, innovation in technology and urban planning could set up sustainable structures and guidelines for energy demand and production which would decouple economic growth from energy consumption, serve as a hospitable vehicle for poverty reduction and lead emissions from an exponential increase to at least a flattening growth curve.

## 1.4 Research Objective

Sub-Saharan Africa is urbanizing at a dramatic rate, which has the potential for many benefits as well as harms. Urban areas have great potential to serve as incubators of economic growth and engines of poverty reduction. Improved infrastructure is a significant component of promoting this growth in urban areas, and planning for improved electricity infrastructure can serve to increase GDP and average annual income, as well as be part of an enabling environment for economic development and poverty reduction. Focusing on electricity use in the cities of the Sub-Sahara is also important because urban areas in the developing world are projected to overtake OECD countries as the largest emitters of GHGs. Therefore developing a model for projecting the electricity demand of a major African city will serve as a foundation for quantifying the costs and benefits associated with proposals for economic development, poverty reduction, and environmental protection as well as acting as a template for other African cities.

The primary research objective of this work is to create a highly disaggregated property and land use urban simulation system for comprehensively projecting the electricity demand of the Korle Bu district in Accra, Ghana, in terms of low, medium, and high population and economic growth rates for the time period 2006 until 2025. In order to meet this primary research objective, the following secondary objectives will also be achieved.

1. To annually model household location choice by matching household attributes to preferred locations using a synthetically generated household population and the actual residential structures in Korle Bu.
2. To annually model commercial location choice by matching business attributes to preferred locations using a synthetically generated employment population and the actual commercial structures in Korle Bu.
3. To annually model the price of each individual plot in Korle Bu.
4. To annually project demographic and economic growth in Korle Bu for use in projecting low, medium and high growth scenarios.
5. To annually model electricity demand for each building and plot in Korle Bu, and then aggregate these demands to determine total projected electricity within the district as well as annual projected demand to 2025.

In total, these objectives comprise a single urban simulation system which describes every building and plot in the Korle Bu district for each year from 2006 until 2025, and thus enabling the disaggregated electricity demand projection.



# **Chapter 2**

## **Modeling the City**

## 2.1 The Science of the City

The study of the city falls under different names: City and Regional Planning, Geographical Sciences and Urban Studies, Town and Country Planning, Urban Economics, or Public Administration among many others. One of the reasons there are so many different approaches to studying the city is because understanding urban dynamics bridges many different disciplines of research. The Science of City and Urban Geography is interdisciplinary in nature; it includes economics and demographics, statistics and engineering, public policy and urban design, cultural studies and architecture.

The city can be defined in terms of its political boundaries as a subdivision of the state or by its contiguous urban area. Therefore, a city or town may have a politically defined boundary which is not coterminous with the urban area. Sometimes the aggregation of cities combine to create larger, continuous urban areas, while at other times, more rural municipalities, which are more similar to a district or a county, seek to include areas which are both rural and urban within their borders. The point being, cities generally have two different boundaries, one that defines the jurisdiction for a political entity which has some rights to govern within that area, and another that describes a contiguous urban area, which may be an aggregation of numerous political entities, on many different levels: local, county, district, regional, state or even national. The *de facto* city is more concerned with the contiguous urban area and how those political entities function and govern.

The fundamental unit of a city is property. While a city is defined in terms of its boundaries, it is also subdivided internally, with all parcels having some form of ownership, whether private, public, permanent or temporary. Generally speaking, residential land uses, such as a single family home, is a singularly subdivided piece of property which is owned by an individual or family. A more complicated form of ownership involves condominiums or higher density residential land uses. Commercial land uses may also be individually owned by a person or business, but often some designated part of the property is leased to a corporation for a given amount of time. Industrial operations may also be owned or leased. Institutional uses are generally owned by the public, as designated within a governmental body. Finally, rights-of-ways and easements are a form of ownership designated for public and private infrastructures, such as highways and roads, electricity and gas, water and sewer, stormwater and drainage, as well as telecommunication facilities.

While property which has been subdivided into individual lots, parcels, or right-of-ways is the primary unit of analysis, the primary means for describing these individual units is in terms of land use. There are four primary urban land uses: residential, commercial, industrial, and institutional. A parcel can also be described in terms of the existing use on that subject piece of property, for example, an apartment building may be considered as a medium density residential use. Furthermore, that existing use, may or may not comply with those uses which have been permitted for that subject parcel. This regulation of what is permitted on an individual piece of property is called zoning or sometimes current planning. A zoning designation serves to regulate what uses are permitted on a subject property, as well as the levels of density (residential uses which are measured in the number of dwelling units per acre or m<sup>2</sup>) or intensity (commercial and industrial uses which are measured in floor area ratio which is a comparison of the total building floor area to the property area) which are permitted, among other things. Finally future land use planning guides the development of large areas within a city, district or region as to what types of uses and development are consistent with the vision for that particular area. One such example could be an area which has been designated for Intensive Development, where more intense industrial operations are permitted, such as a harbor or trucking terminal. Comparatively a future land use designation of Environmental Conservation indicates a community vision which involves protecting habitat and fauna,

indigenous or endangered species, or groundwater recharge areas.

Studying the city is interdisciplinary in nature, but the two primary disciplines which serve as the foundation for Urban Sciences are demography and economics. Demographics and the associated use of statistics has many uses, but from the perspective of city planning focuses on domestic activities of individuals and their associated households, which assumedly are located on residential land uses. Within the context of city planning, economics is focused on the analysis and classification of jobs and businesses, which are primarily commercial or industrial. Additionally, economic analysis also identifies whether a particular business is associated more with providing local services, such as a restaurant or barber shop as compared to a business that is more involved with services which are provided outside of the local region, such as an international legal or engineering firm. Institutions or public services are also an important part of the city. Institutional analysis can focus on: Public Education (Universities, Colleges and Schools); Public Health (Hospitals and Clinics); as well as Public Safety (Military and Police). Infrastructure analysis is often a synthesis of engineering, which involves the design and construction of facilities (transportation, electricity, stormwater, potable water and sewer, telecommunications, and sometimes even parks and recreation) with public administration, which is more concerned with programming and finance.

### **2.1.1 Simulating Urban Dynamics**

To understand the dynamics of disaggregated demands, as exhibited by individuals, households or businesses located within a city, it is necessary to be aware that we are dealing with a complex system which is dominated by non-linear and interactive processes. Micro-level actions based on local interaction and their urban environment are responsible for the “emergence” of consumption patterns at a macro-level. While at the same time, changes in urban planning policies can create new opportunities and constraints which affect the micro-behavior of individual “agents” and influence the configuration of demand patterns. (Da Fonseca Feitosa et al. 2010)

The complexity inherent to disaggregated demands imposes serious difficulties to the use of deduction, intuition or hand calculation in the process of understanding this phenomenon. Regarding this issue, computer-based simulations have been pointed towards as the most appropriate tools for understanding complex systems. Complex adaptive systems (CAM) and multi-agent systems (MAS) in particular, represent a promising approach towards addressing the complexity of disaggregated demands. By nature, complex adaptive and multi-agent systems focus on individual behavior within a certain spatial environment and how the interactions of these individuals manifest in the construction of global frameworks. It deals with many autonomous and explicitly located entities, or agents, which react to their environment and make decisions according to a set of rules. (Da Fonseca Feitosa et al. 2010)

#### ***The Limits of Modeling Cities***

One of the key questions facing urban modelers is exactly how much detail is needed. The mainstream trend in urban transport and land use modeling is more and more towards disaggregation. Activity-based travel models have become the state of the art and agent-based land use models are proliferating. There are persuasive reasons for this trend including a growing individualization of society, the increased dominance of urban life styles, and the tendency for location and mobility patterns which are more diversified. Disaggregate models capture this heterogeneity. Still, some have argued that such attempts at microsimulation for large modelling projects failed to deliver in time, did not become operational for anyone other than the author, got lost in data collection and calibration and did not reach the state of policy analysis or simply remained in the academic environment and produced only PhD theses. One argument is based on the idea that when models include more information than necessary, they actually become exactly what is being simulated.

*"Simplifying assumptions are not an excrescence on model-building; they are its essence. Lewis Carroll once remarked that a map on the scale of one-to-one would serve no purpose. And the philosopher of science Russell Hanson noted that if you progressed from a five-inch balsa wood model of a Spitfire air plane to a 15-inch model without moving parts, to a half-scale model, to a full-size entirely accurate one, you would end up not with a model of a Spitfire but with a Spitfire".*

Robert M. Solow (1973)

This approach begs the question, how much micro is too much? Planners seeking to develop a more aggregate approach point towards constraints of data collection, computing time and stochastic variation and suggest that for each planning problem an optimum level of conceptual, spatial and temporal model resolution suggests to work towards a theory of balanced multi-scale models which are as complex as necessary for the planning task at hand and "as simple as possible but no simpler". (Wegener 2009)

In this work we tend towards higher levels of disaggregation and complexity, because the very systems we are simulating are in fact very complex. In fact many urban systems have already been modelled and can be observed as they operate in real time. Transportation monitoring systems are capable of observing traffic and trips as they occur, water and sewer systems can give real-time read outs of pressure and flow from a remote location, while children in schools can be monitored by their parents from their homes. Simplifying for the sake of simplicity does not necessarily result in better results, while likewise building a more complex simulation also does not guarantee results. Entity oriented modelling offers a new direction with a capability to synthesize discrete choice approaches with goal oriented and adaptive agent-based models within the context of an urban fabric of physical structures being modeled in real time. Furthermore, computer systems and programming languages has been developed which greatly expand the potential for speed and power.

### **Multi-Agent Systems and Agent-Based Models**

The concept of (computational or software) "agents" stems from the fields of Distributed Artificial Intelligence (DAI) and Multi-Agent Systems (MAS). Common definitions of the term characterize them as autonomous, reactive, goal-oriented, or socially able, just to cite a few. Agent-based models, instead, are most importantly goal oriented and adaptive, and are programmed with an element of learning which is inherent to the agent itself. In a multi-agent system, an agent may be assigned a value or utility, which is dependent on their actions within that environment, but a goal oriented agent may seek to maximize this value and can adapt and learn which actions to take in order to increase their value over time and thus reach a goal. The Erev and Roth algorithm is one example of learning programmed into an agent in order to adapt and reach a specified goal. (Weidlich and Veit, 2008)

### **Discrete Choice Models**

Multi-agent systems for urban simulation systems rely heavily on discrete choice modeling, a path breaking approach to modeling individual actions which was pioneered in the 1970s with Daniel McFadden's theory on Random Utility Maximization. This approach derives a model from the probability of choosing among a set of available alternatives based on the characteristics of the chooser, the attributes of the alternatives, and the proportional, relative utility amongst them. A household choosing among alternative locations in the housing market, which we index by  $i$ , can serve as a simple illustration of how discrete choice models operate within an urban simulation. Take for example each agent, or household, and assume that each alternative choice  $i$  has an associated utility  $U_i$  which can be separated into a systematic part and a random part.

$$U_i = V_i + \epsilon_i$$

Where

$V_i = \beta \cdot x_i$  is a linear – in – parameters function

$\beta$  is a vector of  $k$  estimable coefficients

$x_i$  is a vector of observed, exogenous, independent alternative, specific variables that may be interacted with the characteristics of the agent making the choice

$\epsilon_i$  is an unobserved random term

Assuming the unobserved term is distributed with a Gumbel distribution leads to the widely used multinomial logit model.

$$P_i = \frac{e^{V_i}}{\sum_j e^{V_j}}$$

Where

$j$  is an index over all possible alternatives

$\beta$  is estimated with the method of maximum likelihood

### Formula 2.1 Geometric Interpretation of a Simple Discrete Choice Model

The log of this denominator is called the *logsum*, or composite utility, and it summarizes the utility across all the alternatives. In the context of a choice of mode between origins and destinations, for example, it would summarize the utility (disutility) of travel, considering all the modes connecting the origins and destinations. Thus the *logsum* also has appeal as a comprehensive evaluation measure. (Waddell 2010)

## 2.2 Platforms for Modeling Cities

Regional, urban, city and town planning is interdisciplinary by nature, therefore modeling approaches towards simulating urban dynamics have also bridged many different areas of research. Urban simulation systems trend towards a synthesis of econometric, agent based models with physical representations of urban designed real cities, as they change through time. Infrastructure models, such as those that forecast the dynamics of transportation networks or electricity systems, typically either make projections at a national or regional (supranational) level or focus on a singular infrastructure project within a neighborhood or district. Rarely do infrastructure models forecast dynamics within a boundary that is coterminous with a *de facto* urban area.

The challenge of simulating the urban dynamics of any large city, such as Accra, is to physically model all of the physical infrastructure, including the transportation systems, water and sewer (if they exist), solid waste, storm runoff, public health, safety and education facilities, as well as projecting the daily decisions of households and businesses as well as their associated life cycle as these units progress into the future. Finally, modeled physical infrastructures should animate their functions as if they were occurring in real time, or hypothetically if a change to the system is being proposed. The result is an urban simulation that synthesizes and employs components of economics and demographics, statistics and engineering, public policy and urban design, cultural studies and architecture. This is the comprehensive and complex nature of simulating urban system dynamics of cities as well as their interaction with suburban and rural areas within that region.

### 2.2.1 NetLogo

NetLogo is a multi-agent programming language and integrated modeling environment for developing multi-agent systems and agent-based models in the social and natural sciences. NetLogo was designed in

the spirit of the Logo programming language to be "low threshold and no ceiling," that is to enable easy entry by novices and yet meet the needs of high powered users. The NetLogo environment enables exploration of emergent phenomena. It comes with an extensive models library including models in a variety of domains such as economics, biology, physics, chemistry, psychology, system dynamics and many other natural and social sciences. Beyond exploration, NetLogo enables the quick and easy authoring of models. It is particularly well suited for modeling complex systems developing over time. Modelers can give instructions to hundreds or thousands of independent "agents" all operating concurrently. This makes it possible to explore the connection between the micro-level behavior of individuals and the macro-level patterns that emerge from the interaction of many individuals. (NetLogo 2010)

### *Examples of Application*

One of the first works of real significance in the area of simulation modeling and development research was by Dr. Quang Bao Le. Le et al. developed an innovative and novel multi-agent system for simulating land-use and land cover change for an upland watershed along the central coast of Vietnam. Using Netlogo, Dr. Le developed his VN-LUDAS model, consisting of four modules, which represent the main components of the coupled human-landscape system in forest margins. Le et al. nested the bounded-rational approach based on utility maximization using spatial multi-nominal logistic functions with heuristic rule-based techniques to represent the decision-making mechanisms of households with regard to their agricultural activities. The agent-based architecture allowed integration of diverse human, environmental and policy-related factors into farmers' decision making with respect to land use and presentation of subsequent accumulated outcomes in terms of spatiotemporally explicit patterns of the natural landscape and population. (Le et al., 2005)

State of the art simulation of urban segregation, as well the development of a highly sophisticated urban simulation system, is found in the work of Dr. Flavia da Fonseca Feitosa. Da Fonseca Feitosa et al. built upon previous work developed at the Brazilian National Institute for Space Research (INPE), while synthesizing the work of Bao et al. and important historical foundations (Thomas Schelling) for a parameterized and calibrated hypothetical application of anti-segregation policies in São José dos Campos, Brazil and its environs. Da Fonseca Feitosa's MASUS, Multi-Agent Simulator for Urban Segregation, is a virtual laboratory built in the Netlogo programming environment to explore theoretical issues and policy approaches on segregation. Urban households are represented as individual agents that interact with one another as well as their environment while making decisions regarding whether or not to relocate as well as their actual location choice. Within this structure, urban segregation emerges from the complexity of interactions. (Da Fonseca Feitosa et al.)

Da Fonseca Feitosa et al. used this learning laboratory to explore the impact of income inequality and personal preferences on segregation, and found that decreasing levels of income inequality promote the spatial integration of different social groups within the city. Da Fonseca Feitosa et al. also conducted experiments to explore high-income families' neighborhood preference and revealed that high levels of poverty isolation were maintained even when affluent households did not take into account the income composition of neighborhoods while selecting their residential location. Finally, Da Fonseca Feitosa et al. present results with regard to the equitable distribution of infrastructure investments on clandestine settlements as well as the potential implementation of social mix policies (poverty and wealth dispersion) in Brazil. (Da Fonseca Feitosa et al.)

### **2.2.2 The Open Platform for Urban Simulation (UrbanSim)**

UrbanSim is a software-based simulation system for supporting planning and analysis of urban development, incorporating the interactions between land use, transportation, the economy, and the

environment. It is intended for use by Metropolitan Planning Organizations (MPOs), cities, counties, non-governmental organizations, researchers and students interested in exploring the effects of infrastructure and policy choices on a number of community outcomes. Unlike most multi-agent system and agent-based modeling platforms which have been developed in Java, UrbanSim was completely reprogrammed from Java to Python in 2007, due to the advantage Python has in terms of processing speed for the massive amounts of data that are normally associated with modeling large urban areas. (Waddell et al. 2010)

**Functional Description**

Structurally, UrbanSim is a system of models which predicts choices of individuals, households, and businesses. This urban simulation system relies heavily on discrete choice models for projecting residential, commercial, industrial and institutional location choice. Regression models are used to predict real estate price, while simple allocation models are used to determine exogenous variables such as population or economic growth. Each UrbanSim project has a fundamental spatial unit of analysis, either a parcel, gridcell, or zone, which is normally determined depending on the quality of data available. If comprehensive data is not available, for each and every unit, a synthetic population generator may be used to simulate needed tables, so long as certain statistical parameters are met. The resulting group of tables or baseyear data is then used as input for the models that run sequentially and comprise the larger urban simulation system. As each model is run, the baseyear data is updated to reflect the projected outcome, which is sequentially used as input for subsequent models until the series or annual cycle has

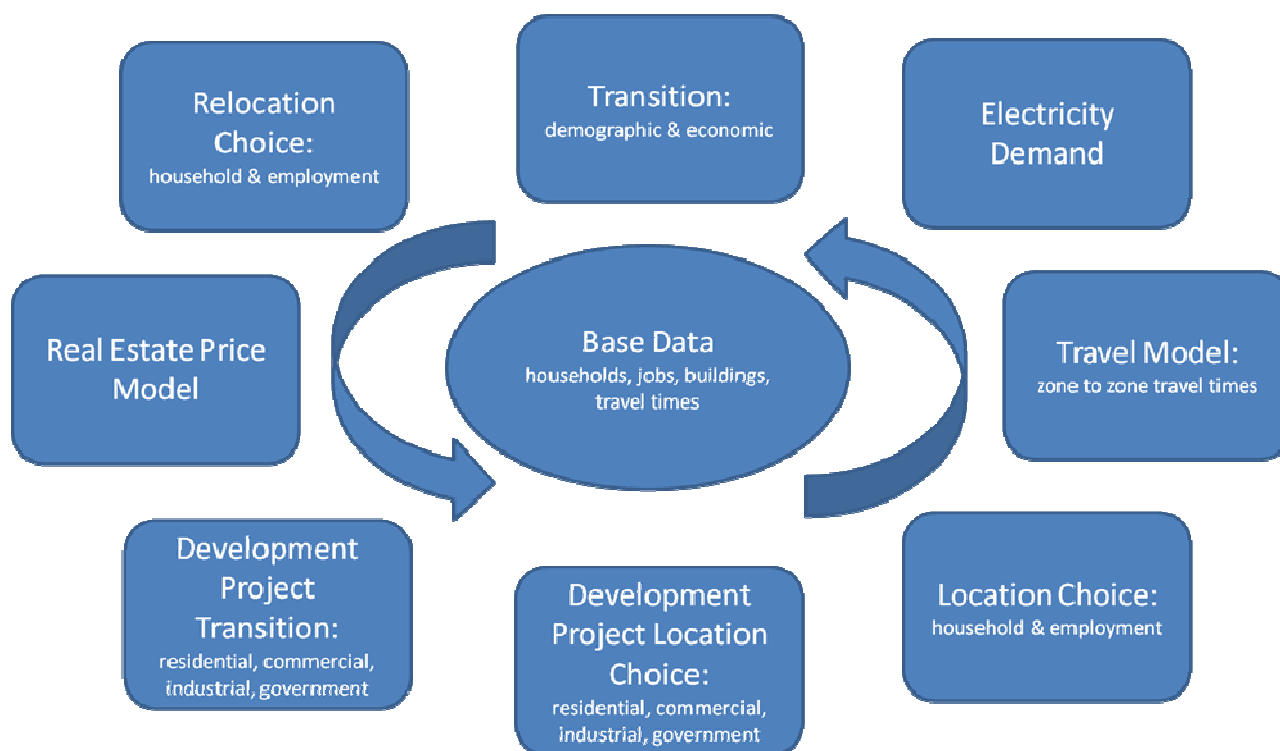

Figure 2.1 UrbanSim Annual Cycle of Model System

been completed for that single simulation year. (Waddell et al. 2010)

Each urban simulation project is typically comprised of 4 different types of models which allocate jobs and households, determine if jobs and household will relocate, chooses where they will locate, and determines land value. These 4 types of models use the attributes of the fundamental spatial unit (parcel, gridcell, or zone) for the dataset (land use, land value, economic and demographic characteristics, and energy consumption) to estimate each model. The Economic and Demographic Transition Models



integrate exogenous forecasts of aggregate employment by sector and control totals for population and households. As sectors grow or decline from the preceding year, jobs are added or removed from the database. Likewise the demographic transition model approximates changes to affect the net result of each time step. These models serve as the interface with an exogenous macroeconomic model. The Employment and Household Relocation Models predict the probability that jobs or households of each type will move from their current location or stay during a particular year. As the utility of different locations increases or decreases as well as the value of the existing location, firms and households may chose to relocate. *Employment and Household Location Choice Models* predict that a job or household that is either new or has moved within the region will be located at a particular site. Buildings are used as the basic geographic unit of analysis. Each job and household has an attribute of space that it needs and this provides a simple accounting framework for space utilization within buildings. Households are further defined by income level and the presence of children or family size. Land Value is modeled using a hedonic regression of the log-transformed property value per square foot. Attributes of the parcel are also used such as infrastructure availability, accessibility, density and neighborhood effects. (Waddell et al. 2010)

### Synthetic Population Generation

UrbanSim is essentially an activity based microsimulation model system that recognizes that fact that disaggregated demand (for transportation, water, electricity, goods and services etc...) is a derived demand, where individuals undertake activities in time and space. The behavioral unit under consideration is the individual person, thus leading to model systems that are capable of simulating activities of individual persons over the course of a day, week, month and year. As activity-based microsimulation model systems operate at the level of the individual, household and person attribute information become necessary for the entire population within the study area. The problem faced by urban modelers is that high quality comprehensive data is virtually never available at the disaggregate level for an entire region or metropolitan area. However, a random sample from a survey is often available and can be used to generate a complete synthetic population with comprehensive data on attributes of interest. The activity based model system can then be applied to this synthetically generated population to forecast disaggregated demand at the level of the individual person. (Pendyala et al. 2009)

Synthetic populations can be formed from the random samples by choosing or selecting households and persons from the random samples such that the joint distribution of the critical attributes of interest in the synthetic population match known aggregate distributions of household and person attributes. Using a heuristic approach called Iterative Proportional Updating (IPU), synthetic populations can be generated

$$\text{Minimize } \sum_j \left[ \left( \sum_i d_{i,j} w_i - c_j \right) / c_j \right]^2 \text{ or } \sum_j \left[ \left( \sum_i d_{i,j} w_i - c_j \right)^2 / c_j \right] \text{ or } \sum_j \left[ \left| \sum_i d_{i,j} w_i - c_j \right| / c_j \right]$$

subject to  $w_i \geq 0$

Where

$i$  denotes a household ( $i = 1, 2, \dots, 8$ )

$j$  denotes the constraint or population characteristic of interest ( $j = 1, 2, \dots, 5$ )

$d_{i,j}$  represents the frequency of the population characteristic (household/person type)  $j$  in household  $i$

$w_i$  is the weight attributed to the  $i$ th household

$c_j$  is the value of the population characteristic  $j$

#### Formula 2.2 Geometric Interpretation of the Iterative Proportional Updating (IPU) Method



where both household level and person level characteristics can be matched in a computationally efficient manner. The mathematical optimization problem takes the form of Formula 2.2 depending on the objective function. (Pendyala et al. 2009)

### ***Multiple Regression Model for Projecting Disaggregated Demand of Public Services***

In order to project disaggregated demand for a specific public service (potable water, electricity, solid waste etc...) a multiple regression model based on property characteristics such as historic consumption, land use, demographic and economic data can be incorporated into the urban simulation system. A multiple regression model is a multivariate statistical technique, which examines the variable being forecasted (e.g. electricity demand) and multiple other variables in order to forecast the implicit nature of a dependent to multiple other significant independent variables.

When using a multiple regression model, it is important to minimize the correlation between predictor variables. If predictor variables are related to each other, a change in one variable will cause other variables to change, resulting in an exaggerated change in the dependent variable. This is the problem of collinearity. Although relationships between predictor variables may be unavoidable, an effort to

$$y = \beta_0 + \beta_1x_1 + \beta_2x_2 + \beta_3x_3 + \dots + \varepsilon$$

*Where:*

y = electricity demand

x = predictor variable: historical consumption, land use, etc ...

$\beta$  = regression coefficient

$\varepsilon$  = residual term

### **Formula 2.3 A Simple Linear Regression**

minimize collinearity is important for maximizing the prediction power of the regression model. (King et al. 2006)

### ***Examples of Application***

UrbanSim is being formally used for planning purposes by a number of local and regional governments mostly in the United States. These city and regional planning organizations include Honolulu, Hawaii's Oahu Metropolitan Planning Organization; Eugene-Springfield, Oregon as implemented by the Oregon Department of Transportation; the Houston-Galveston Area Council; the Regional Planning Agency for Paris, France; Seattle, Washington's Puget Sound Regional Council; the San Francisco County Transportation Authority; and the Southeast Michigan Council of Governments. More recent application has included the SustainCity project which is being led by ETH and is developing a model UrbanSim based on Zurich, Switzerland as well as application in Johannesburg, South Africa, which is being funded by the Council for Scientific and Industrial Research (CSIR). Other academic institutions that are reportedly developing UrbanSim models are the Technical University of Berlin (Germany), the Universidade Federal de Santa Catarina (Brazil), Arizona State University (USA) and the University of Florida, among many others. (Waddell et al. 2010)

## **2.3 Modeling Electricity Infrastructure**

Named the greatest engineering achievement of the 20th century by the National Academy of Engineering (USA), the electrical grid has been called the largest and most complex machine in the world as well as the largest industrial investment in the history of humankind. Electrical power systems are extremely intricate, comprising generation, transmission and distribution subsystems, and in order to keep modern

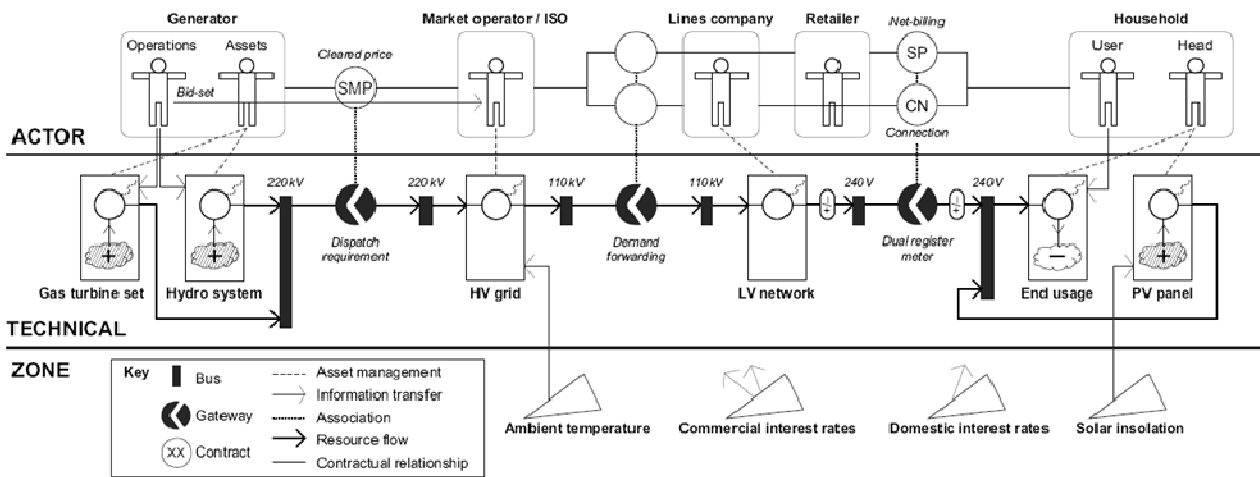

Figure 2.2 Entity Oriented Electricity System Model (Morrison et al.)

systems operating smoothly, different kinds of software are used at different operational stages and levels. For example, Supervisory Control and Data Acquisition (SCADA) and Energy Management System (EMS) software is used to supervise, control and manage generation and transmission systems, and Distribution Management System (DMS) software is used to manage distribution networks. (Sun & Tesfatsion, 2006b)

Electricity system analysis can be built around three conceptual layers comprising primarily actors, infrastructure, and zones. Actors are typically grouped in accordance with their legal identity, for example power generation companies, load-serving entities and independent system operator within the domain of wholesale markets. Likewise actors in retail markets are defined in accordance with their legal identity such as retail power distributor and consumers at their end-use. The technical layer is structured around the processing of resource stocks and flows, high-voltage transmission grids, low voltage distribution networks, as well as end use power consumption or production. Interconnected control domains are interfaced by gateways which reflect various types of legal contracts which may be managed by the ISO for wholesale transactions or possibly LSEs in the case of dual register meters (net metering). The zonal layer incorporates conditions that are more exogenous to the system such as weather, macroeconomics, or the site suitability for implementation of a new technology. (Morrison et. Al, 2008)

Because of the technical nature of the traded good, electricity markets rank among the most complex of all markets operated at present. Supply and demand have to be balanced in real time, considering transmission limits and unit commitment constraints. These complexities drive most classical modeling methods to their limits. Equilibrium models either do not consider strategic bidding behavior or assume that players have all the relevant information about the other players' characteristics and behavior. Due to the difficult real-world aspects, such as asymmetric information, imperfect competition, strategic interaction, collective learning and the possibility of multiple equilibria, more and more researchers have been developing agent-based models for simulating electricity infrastructure and market dynamics. (Tsfatsion & Weidlich 2006)

### 2.3.1 Accounting Frameworks

Developed at the Stockholm Environment Institute, the Long range Energy Alternatives Planning System (LEAP) is a widely-used software tool for energy policy analysis and climate change mitigation assessment. LEAP is an integrated modeling tool that can be used to track energy consumption, production and resource extraction in all sectors of an economy. It can also be used to account for both energy sector and non-energy sector greenhouse gas (GHG) emission sources and sinks. In addition to tracking GHGs,

LEAP is used to analyze emissions of local and regional air pollutants, making it well-suited to studies of the climate and the co-benefits of local air pollution reduction. (SEI, 2009)

LEAP is not a model of a particular energy system, but rather a tool that can be used to create models of different energy systems, where each requires its own unique data structures. LEAP's modeling capabilities operate at two basic conceptual levels. At one level, LEAP's built-in calculations handle all of the "non controversial" energy, emissions and cost-benefit accounting calculations. At the second level, users enter spreadsheet-like expressions that can be used to specify time-varying data or to create a wide variety of sophisticated multi-variable models, thus enabling econometric and simulation approaches to be embedded within LEAP's overall accounting framework. LEAP is intended as a medium to long-term modeling tool with most studies using a forecast period of between 20 and 50 years. LEAP is designed around the concept of long-range scenario analysis. Scenarios are self-consistent storylines of how an energy system might evolve over time. (SEI, 2009)

The advantage of LEAP is its simple straight forward approach to modeling energy supply and demand in a manner that is scalable to economies which are multi-national in nature (such as West Africa) or detailed down to the size of a large city or district within a city (such as Korle-Bu in Accra). The interface is very intuitive, user friendly, and instructive. It is also a very good learning tool and is being used by numerous developing countries for exactly that purpose. The general approach of LEAP is to aggregate data in an accounting framework, which doesn't lend itself to highly disaggregated approaches which may incorporate large amounts of detail at the individual household or business level. It is also unclear how LEAP would operate when coupled with another modeling platform, such as those used to simulate urban dynamics. Nonetheless, LEAP is an excellent framework and is being used by the Ministry of Energy in Ghana, where a number of different models of Ghana's energy infrastructure have been developed and deployed. (SEI, 2009)

### **2.3.2 Optimization Models**

Ghana's electricity system has been in the process of moving from a centralized structure based on set tariffs or contractual relationships between purchaser and buyer towards a deregulated one where wholesale trading and the various dynamics of supply and demand decisions dynamics are incorporated into the system. Optimization models are particularly useful for modeling centralized systems or decisions made by single organizations, such as in a centralized structure, but as Ghana plans to deregulate its electricity markets, more sophisticated models will be needed. The US based consulting firm Nexant technologies has developed just such a system for Ghana as part of the USAID funded West Africa Regional Transmission Stability Study. Nexant has developed two separate modeling frameworks, the Elfin optimum (Least Cost) generation expansion plan and the GE-PSLF model to project load flows and dynamic responses within the network. (Nexant 2005)

The Elfin modeling framework was developed to seek economical methods to increase the economic and environmental efficiency of energy investments, while the GE Positive Sequence Load Flow model is an analytical tool to perform transmission planning for load flow studies. Elfin includes generation planning analysis to adequately meet demand for electricity at a minimum cost through the incorporation of two main components: generation production forecast and generation optimization. The Elfin generation forecast uses a probabilistic load duration curve simulation method to dispatch resources to meet demand described by a load input curve, while the resource model makes allocations through an optimization process that includes iterative testing and life cycle cost benefit analysis. One of the main goals of the GE Positive Sequence Load Flow model is to design a large scale transmission system which operates in a safe and reliable manner. While Nexant Technologies' modeling approach for the West

Africa Regional Transmission Stability Study is based on sound examples (including implementation in Florida, New York, California, France, China, and Indonesia) in many regards it is ideologically path dependent. This is particularly true in terms of modeling demand, which is largely aggregated and overly simplified. (Nexant 2005)

### **2.3.3 Equilibrium Models**

Approaches which explicitly consider market equilibria within a traditional mathematical programming framework are classified as equilibrium models. Two common types are the Cournot competition, where firms compete in quantity strategies, and the Supply Function Equilibrium (SFE), where firms compete in offer curve strategies. Both models are based on the concept of Nash equilibrium, the market reaches equilibrium when each firm's strategy is the best response to the strategies actually employed by its opponents. The SFE approach presents some advantages with respect to more traditional models of imperfect competition since it does not rely on the demand function, but on the shape of equilibrium supply functions. (North et al., 2002; Veit, Fichtner, & Ragwitz, 2004; Ventosa, Baíllo, Ramos, & Rivier, 2005)

MARKAL (an acronym for MARKal ALlocation) is an example of an equilibrium modeling framework of energy systems that uses a technology-rich basis for estimating energy dynamics for one or several regions over a multi-period horizon. MARKAL was developed by the Energy Technology Systems Analysis Program (ETSAP), which is an extension of the International Energy Agency (IEA). MARKAL computes energy balances at all levels of an energy system: primary resources, secondary fuels, final energy, and energy services. The model aims to supply energy services at minimum global cost by simultaneously making equipment investment and operating decisions and primary energy supply decisions, by region. The choice of generation equipment (type and fuel) incorporates analysis of both the characteristics of alternative generation technologies and the economics of primary energy supply. The modeling framework takes into account global features as well as local decisions thus making MARKAL a vertically integrated model of the entire energy system. (ETSAP 2009)

Alam Mondal's work at the Zentrum für Entwicklungsforschung focuses on the relationship of economic development and sustainable energy paths in Bangladesh. Through the development of a MARKAL energy use model for Bangladesh, Mondal's work examines the potential contribution of renewable energy to the future power supply mix under least cost analysis. The scientific innovation of his research is to specify national energy strategies which may arise in the further development of the Bangladesh energy sector with a special focus on renewable energy technologies. (Mondal 2010)

### **2.3.4 Multi-agent and Agent-based Models**

Energy systems exist to provide industry, commerce, households and institutions with fuels and energy-services. In addition to financial cost and reliability imperatives, these systems are now being asked to perform across a range of sustainability criteria. Most national systems fall well short on this second count and governments need to promote a suitable transition. The development of suitable public policy has necessitated the need for sophisticated simulation techniques, particularly considering the technical and commercial complexities involved, the multi-criteria nature of the policy problem, and the fact that most interventions will interact. (Morrison et al., 2008)

Agent-based simulations are an important next step from equilibrium models, as the problems under consideration become too complex for a formal equilibrium framework. Static models seem to neglect the fact that agents learn from past experience, improve their decision-making and adapt to changes in the environment (e.g. competitors' moves, demand variations, or uncertain hydro flows). Integrated

simulation models can represent strategic agent decision dynamics by a set of sequential rules that can range from scheduling generation units and constructing offer curves to individual household and business decisions. Adaptive agent based simulation techniques can shed light on features of electricity markets that static models ignore and are helpful in the analysis of new regulatory measures and market rules. Multi-agent and agent-based simulation systems present the potential framework to explore the influence that repetitive interaction of participants exerts on the evolution of wholesale and retail electricity markets. (Tsfatsion & Weidlich 2006; Sun & Tsfatsion, 2006b)

### ***Entity Oriented Modeling***

Highly disaggregated and relatively literal energy system simulations represent an emerging field, as well as an important type of simulation system, which may also be referred to as a Complex Adaptive System (CAM). This type of high resolution, bottom up approach which not only includes each plant, connection, actor, decision and transaction but also the dynamic, networked infrastructure system is referred to as Entity-Oriented (EO) modeling. EO modeling is a style of simulation where all relevant entities in the problem domain are represented in a relatively concrete form. In terms of electricity power systems all relevant entities will generally include all actors and agents within the system: from the domain of high-voltage transmission, centralized power generation and wholesale markets; to low voltage distribution, distributed power generation, retail markets; as well as all the functions implicit to disaggregated demand at the fundamental level of analysis: the household, business, industry, or institution. (Morrison et al., 2008)

The advantages and benefits of entity oriented models are derived from their nature as a bottom up approach which is capable of accommodating high resolution, localized simulations that focus on sections of the overall system. EO models capture network dynamics naturally, because they are well suited to system architectures and institutional arrangements where these dynamics are likely to develop. EO models are also particularly useful for modeling demand, since demand from the most fundamental disaggregated unit of analysis is the primary driver of actions. EO models are also particularly useful for incorporating the idea of distributed management and distributed systems as well as modeling the network dynamics which arise from the capacitated nature of networks. This is an important advantage since it is also likely that future energy systems will be strongly status aware in order to respond to changing circumstances in an intelligent manner. (Morrison et al., 2008)

Despite being detail intensive, entity oriented models are not fundamentally difficult to calibrate, so long as adequate data is available. Comparatively, other models often require abstract causalities to be estimated and can be quite sensitive to inaccuracies. EO models are also capable of providing insight into the way energy systems might be prompted to evolve from their present state towards pathways of energy sustainability. EO systems modeling offer the ability to observe and understand *butterfly effects* within the system, how seemingly minor network dynamics can affect overall trajectories (such as in long-range weather systems). Finally EO modeling is very capable of integrating actor/agent based modeling for investigating fundamental interactions with social and economic systems. This type of *bounded rationality* is used to describe decision-making which sidesteps the doctrines of (Bayesian) maximized subjective expected utility and discounted profit stream, and instead recognizes that actors, whether domestic or commercial, have limited knowledge, limited information gathering and processing abilities and different preferences and perceptions as to future states of the world. (Morrison et al., 2008)

### ***Justification for Improving Empirical Derivations of Disaggregated Demand***

Energy demand forecasting is an essential component for energy planning, strategy formulation for sustainable futures and developing energy policy recommendations. The task is challenging in developing

countries where necessary data, appropriate models and required institutions are lacking. Most energy demand models focus on a single approach such as: econometric or end-use; demand analysis by focusing on elasticities of demand and their variability among or across studies; or comparison of forecasts with the actually demand of industrialized countries. To date, we are unaware of any work that has attempted to capture the broad range of approaches and their methodological underpinnings considering the policy perspective of the developing world. Furthermore supply shortage is quite common in developing countries for commercial energies in general and electricity in particular. Consumption does not necessarily represent actual demand due to the existence of unfulfilled or suppressed demand. Finally, the possibilities of “leapfrogging” technological developments render unthrive the developing world from the path dependence experienced in industrialized countries. (Bhattacharyya & Timilsina, 2009)

Projected energy demands are often found to deviate from the actual demands due to limitations in the model structure or inappropriate assumptions. One review of energy demand forecasts in the United States, found that most forecasts overestimated demand by 100%. The models employed suffer from a long list of limitations including burying analytical assumptions in “black boxes” which are difficult to evaluate and reproduce the results. Others use inaccurate characterizations of the behavior of economic agents or group consumers into a few representative agents that represent the millions of decisions made by millions of individuals. (Bhattacharyya, Timilsina, 2009; Craig et al. 2002; Laitner et al. 2003)

A weak quantitative means for projecting demand generally results in load serving entities passing increased costs downstream to retail markets. This is largely a result of strategic behavior in the wholesale electricity markets where each agent can potentially influence market prices by bidding above marginal cost. While a rational, profit-seeking behavior, wholesale electricity regulation permits this type of behavior when competition in the retail sector is not providing a counter-balance. (Weidlich & Veit, 2006; Ventosa, Baillo, Ramos, & Rivier, 2005)

### Examples

Researchers at Iowa State University have developed Open Source Software (OSS) of an agent-based framework for testing the dynamic efficiency and reliability of the U.S. Federal Energy Regulatory

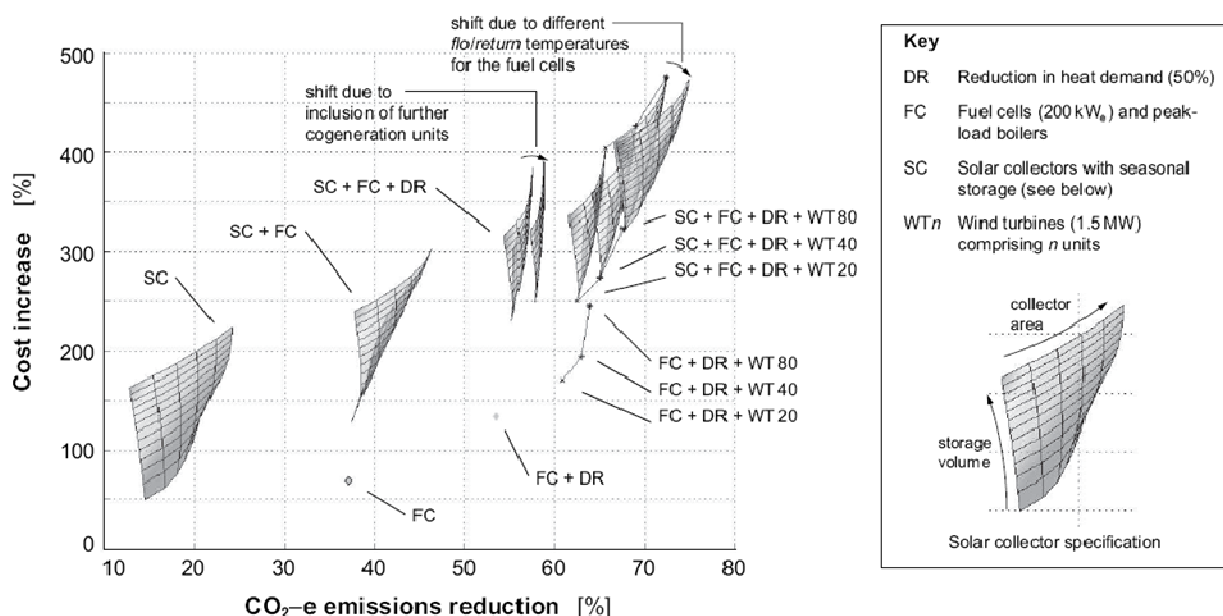

Figure 2.3 Feasibility analysis for 200 kW neighborhood fuel cells operating in a range of configurations and control settings.

Commission's (FERC) proposed Wholesale Power Market Platform. This framework, which is referred to as AMES (Agent-based Modeling of Electricity Systems), models strategic traders interacting over time in a wholesale power market that is organized in accordance with core FERC recommended features and that operates over a realistically rendered transmission grid. This state of the art agent-based wholesale market simulation uses a derived form of the Erev-Roth stochastic reinforcement learning algorithm for each profit seeking Generator, which learns over time which marginal cost function to report to the ISO based on the profits it has earned from previously reported functions. The AMES model demonstrates the inherent and quasi-monopolistic nature of power generation companies to collude and game wholesale electricity markets in the United States, while load serving entities, generally pass costs along to the consumer with end users being provided few if any choices. (Tsfatsion & Weidlich 2006; Sun & Tsfatsion, 2006b)

Researchers at the Technical University of Berlin have developed Xeona (extensible entity oriented optimization-based network mediated analysis) an object-oriented simulation environment where demand drives system evolution as it responds to market dynamics and public policy. Xeona has been used to assess how various schemes for different types of land uses in southern Germany can compete with district heat and electricity from the incumbent municipal utility. The study considered the merits of installing natural gas fired fuel cells for a block of low-rise apartment buildings as well as the potential network interactions with renewable energy opportunities, such as solar systems and wind generation. The study found that technological multi-criteria performance is sensitive to the quality of local integration. The study also found significant positive social externalities despite the fact that none of the proposed options qualified as a fully commercial proposition. (Morrison et. Al, 2008)

## **Chapter 3**

# **The Physical and Human Geographic Patterns of Accra**



### 3.1 An Introduction to Accra

This chapter presents a description of Greater Accra in terms of its physical and human geographical environment. The physical geography of Accra is described in terms of spatial land development, existing infrastructure, and the existing land use patterns. This includes a discussion of the consequences of urbanization, an assessment of transportation, water and sewer, and solid waste services, and an inventory of the existing industrial, institutional, commercial, and residential land uses. Likewise, Accra's human geography is described in terms of its politics, economics, and demographics. A discussion of the different instruments for revenue generation including means of taxation is presented and followed by an inventory and assessment of the economic and microeconomic characteristics as well as profiles of demographics including households and their mobility. Electricity is given individual attention in the subsequent chapter.

#### 3.1.1 A Brief History

Most local experts equate the establishment of Accra with the development of a coastal fishing village in the late sixteenth century. The earliest known settlers on the stretch of coastline now named Accra were the Kpesi people. Ga-speaking migrants from the "Niger country" reached this area in the sixteenth century, made their homes among the Kpesi and absorbed them into their communities. This fishing village was east of Korle Lagoon, but eventually would expand to encompass the oldest adjoining parts of present-day Accra, in particular, Jamestown and Ussher Town. Archeological evidence suggests that the village was spatially organized around the sheltered harbors with low-density shelters adjoining the coastline in an unplanned fashion. (Grant 2009)

During the first part of the colonial period, the slave trade began to reinforce the development of coastal trade centers, where warehouses and permanent installations were needed. During this time a number of forts were built in what is known as present-day Accra (Fort Ussher by the Dutch in 1605, Christiansborg Castle by the Swedes in 1657, and Fort James by the British in 1673). These three forts, all

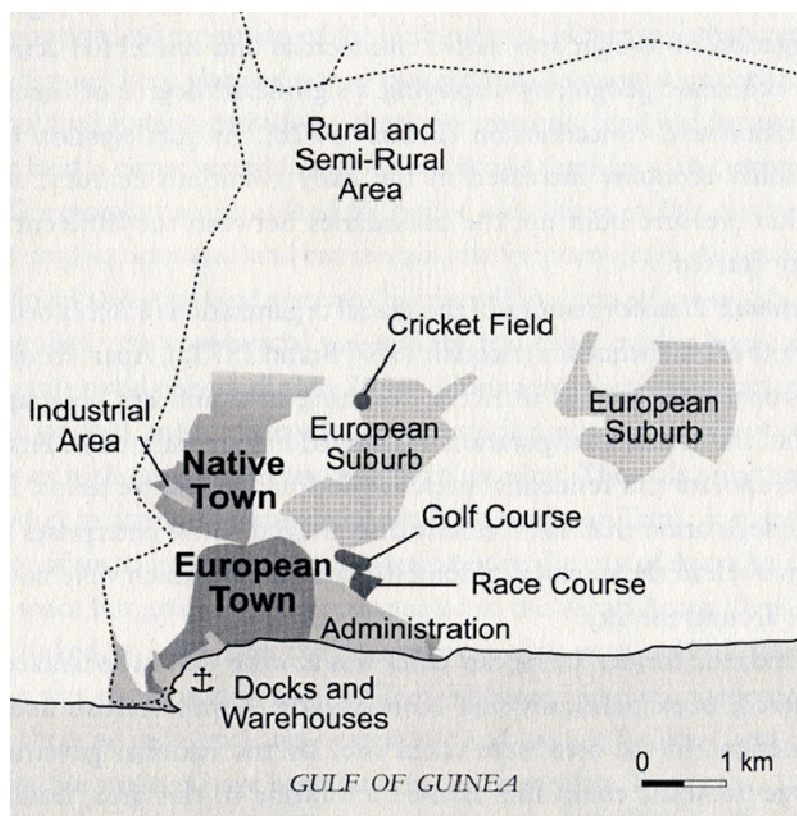

Figure 3.1 Spatial Organization of Accra during the Colonial Period (Grant)

within three miles, formed a nucleus for foreign commercial enterprise in the early colonial period. In proximity to these forts were walled Ga villages which were oriented towards trading with the European merchants. Scattered settlements connected by footpaths rather than an urban clustered center characterized the emerging organization of Accra. (Grant 2009)

The second part of colonial development involved the British consolidation of power on the Gold Coast in 1874, when they defeated the Ashantis. The rise of Accra as an urban center dates to 1877, when the colonial headquarters were relocated there from Cape Coast. One reason for the move related to the earthquake of 1862, which had severely destroyed large portions of Accra, and presented colonial rulers with an opportunity to plan, rebuild and reorganize the space. During the 19<sup>th</sup> century the role of the forts changed to administration centers for officials, troops and later police. The British also attempted to improve sanitation and living conditions in the area as well as make spatial distinctions for foreign and domestic sectors. European commercial and residential areas were clearly distinguished from domestic commercial and residential areas. The Town and Country Planning Ordinance of 1945 was the basis for zoning and building codes which was strictly enforced in the European Central Business District. This act has remained in effect and is administered by the Town and Country Planning Department even though the ordinance was enacted prior to the foundation of Ghana as a Republic. (Grant 2009)

During the 20<sup>th</sup> century and in particular from 1920 onwards, Accra continued to develop as a warehouse city rather than a factory city with commerce replacing government as the primary element in the urban based economy. A major reason for this was the cocoa boom of the 1920s that deepened the interdependence of Accra with the external economy. In 1957 the Republic of Ghana was founded and led by Kwame Nkrumah, a period which is characterized with focus on infrastructure investment and programs aimed towards promoting the economic development of industries. It also was a period that witnessed Ghanaian businesses monopolizing markets and many foreign industries pulling out of the country. Spatially, this period is characterized by a decline of foreign corporate and residential presence, the de-Europeanization of the central business district, and rapid population growth including the rise of national entrepreneurship and a significant expansion in the number and size of domestic businesses. (Grant 2009)

### **3.2 Greater Accra's Physical Geographic Patterns**

Evidence suggests that even though the growth rate has been consistent nationally; the share of population growth is shifting considerably from rural to urban areas. Population trends indicate that by 2010, more than half of Ghana's population will be living in urban areas, with urbanization expected to reach 65 percent by 2030. Greater Accra is the best example of this urbanization, with its sprawling urban expansion into the surrounding rural spaces. The annual growth rate of Accra is 4.4% with the city predominantly growing towards the west (including Awoshie, Kwashieman, LaPaz, Abeka, North Odokor and the far eastern suburbs (Nungua and Teshie). Areas like Burma Camp, Osu and La have also shown increases in population, while localities adjoining Accra such as Dome, Taifa, Gbawe, New Achimota, Anyaa, Santa Maria, Amanfrom, Nii Boye Town, Mallam, Kissieman, Agboba, which were classified as rural in the 1984 census, have attained urban status in the 2000 census. (The World Bank, 2008) A large conurbation has also been created with Tema, which has taken in La, Teshie and Nungua. Areas like Madina, Adenta, Taifa, Ofankor and Pokase which only a few years ago were classified as Ga Rural District have now firmly become part of the Accra – Tema conurbation. Tema has also expanded to include Ashaiman, a city of more than 100,000. (The World Bank 2008)

A recent study (Angel et. Al 2005) reveals that the built up area in the Accra Metropolitan area increased from 133 square kilometers in 1985 to 344 square kilometers in 2000. The existing urbanization pattern

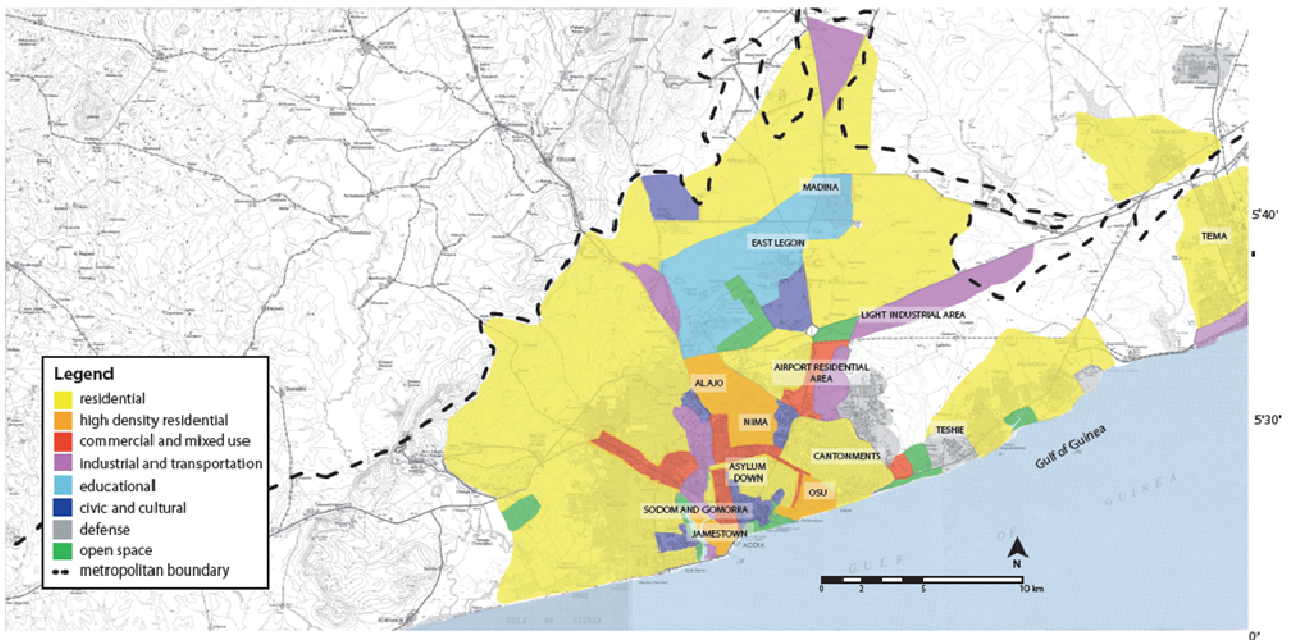

Figure 3.2 Greater Accra Metropolitan Area with Some of Its Neighborhoods and Land Uses (Columbia Accra Studio 2003)

reveals a historically rooted central urban core, which has retained some vestiges of its British Town Planning design, while clearly expressing a synthesis from the imprint of a more recent Ghanaian influence. The inner core of the city is relatively dense, with the replacement of residential by commercial users in some places. The more recent growth of Accra is typified by an organic, uncontrolled, low density peripheral expansion with a rate of growth which is occurring at a much more rapid pace than the central urban population growth. This type of expansion is illustrated by the an ad hoc transformation of Ga District by local tribal rulers (the Nana), from agricultural and forest lands to low density single family housing, and a variety of local commercial uses. (The World Bank, 2008)

Planning in Greater Accra can be described as sporadic and non-compliant at best. Within the context of decentralization, the District and Metropolitan Assemblies (DAs and MAs) have been entrusted with

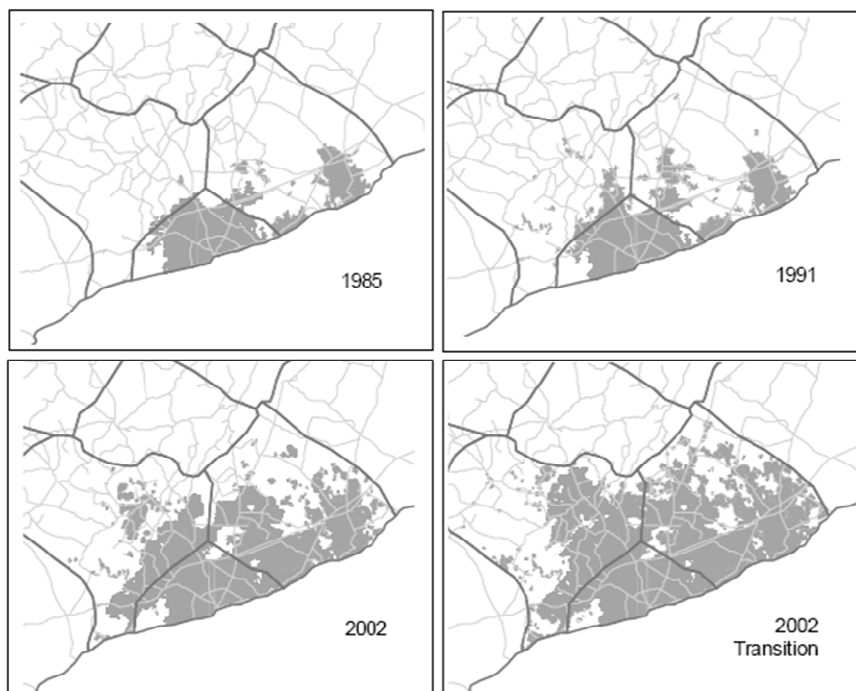

Figure 3.3 Urbanization of Accra from 1985 to 2002 (Yankson)

significant responsibilities related to planning and enforcing the physical development within their administrative boundaries. However it is evident that links between the national planning system and the local authorities are extremely weak. The Greater Accra Metropolitan Structure Plan was developed in 1991 to plan for future growth, but enforcement remains a challenge as there is very limited coordination between the Central Government agencies and metropolitan assemblies. This has resulted in a lack of planning that has benefited the private sector. Without any active enforcement of planning standards, any individual can hire a surveyor (who may or may not be certified by the District Assembly) to develop a layout plan for a discrete development. These layout plans are developed randomly without any consideration for infrastructure, and unless the property requires a title, it normally will not pass through the District Assembly. There is no reliable process for review of permitted uses as part of building permitting, zoning is ineffective and review predominantly does not exist, consideration of impacts as well as the demand for infrastructures as part of a capital improvement plan and comprehensive planning process is non-existent. (The World Bank 2008)

Due to haphazard development in Greater Accra, a responsive disposition rather than a systematic proactive approach to planning that takes into account a multitude of stakeholders will be required. In Accra, new land owners are created quite frequently, but it is impossible for the land sector agencies to keep their records up-to-date. As land owners develop land in all sectors of the city's periphery, often without the knowledge of the land sector agencies or the city authorities, the city's boundaries expand as people build on such lands without either development or building permits. Planning authorities can hardly provide exact statistics about the city's boundaries as illegal settlements continue to sprawl into

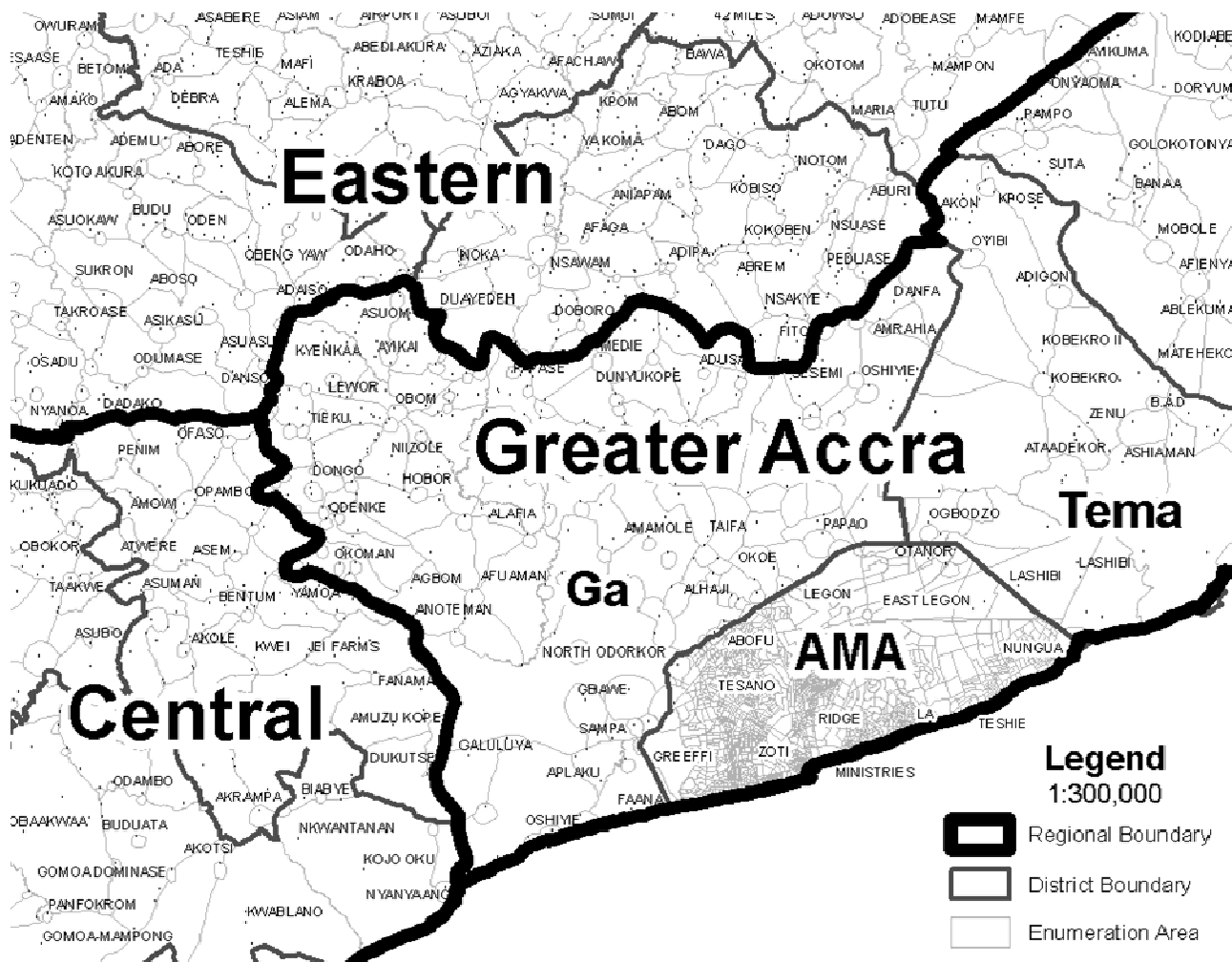

Figure 3.4 Political Subdivisions of Accra (by Author)



the suburbs. Additionally, as land owners develop, particularly in the urban periphery, utility providers can hardly keep pace in all parts of the city, nor should they. These types of development impacts have a significantly adverse effect on the implementation of development controls as well as infrastructure and institutional planning. It is likely at some point in the future, costly development impact fees will be needed to counteract years of unplanned and unregulated urban sprawl. Finally, the massive expansion of Accra in all directions indicates the presence of an active private sector involved in the land markets which benefits from this chaotic environment. This is particularly evident in the areas of Ga where titles for customary lands that have been traditionally used for rural and agricultural purposes are being subdivided and used for low density single family homes. (The World Bank 2008)

### Consequences of Urbanization

The urbanization process as manifested in Ghana has resulted in increasing poverty in urban areas. It is estimated that 1.9 million people live below the poverty line in Ghanaian cities, many whom are admittedly uncounted or undercounted by the Statistical Service. While rural poverty is declining, urban poverty is increasing, and based on the increased migration from rural to urban areas it can be expected that worsening living conditions of the urban poor will continue. The 2005 GPRS also notes that households belonging to the self-employment category have a greater chance of falling into poverty in urban areas compared to rural areas. Additionally, urban poverty has worsened the conditions of women, especially female-headed households, who are statistically significant among the urban poor. (NDPC 2005)

One of the most observed consequences of urbanization is the rapid proliferation of the housing stock. Household formation and housing stock have increased sharply in Greater Accra over the past two



Figure 3.5. Compound Houses in Nima (By Author)

decades (1984 – 2000), largely because of a rapid and significant population shift. (Ghana Statistical Service 2003) A further examination of the housing patterns of the Greater Accra Metropolitan area reveals that close to 42 percent of the population lives in compounds followed by 18 percent in separate houses and 16 percent in semi-detached houses. Compound housing is typically characterized by a large number of households and groups of between 10 and 30 rooms with kitchen and toilet facilities arranged around an open court that is used as a common living space.

Additionally, a recent study by Columbia University illustrates that in 2001 more than half of the urban population in Ghana were living in slum settlements. Approximately 60% of the Greater Accra metropolitan area is comprised of low-income neighborhoods that are characterized by high density, poor infrastructure including low housing quality, existence of informal businesses, and irregular development without any planning or consideration for future expansion. A lack of provisions for affordable housing is also a significant consequence. For example an SSNIT unit in Tema is estimated at \$20,000 to \$25,000 USD, which is extremely high, compared to an average annual per capita income of \$450 USD. (The World Bank 2008) Closer examination of the living conditions reveals that due to poor shelter options, people are forced to live in overcrowded tenements. Overcrowding of settlements poses a serious public health and safety issue, as well as reflecting the gap between the rich and the poor in terms of meeting shelter needs. Accra needs between 14,000 and 16,000 units per year to meet existing growth rates, not taking into account the more than 100,000 units needed to reduce existing congestion. (Columbia University 2003)

### **3.2.1 Infrastructure** **Transportation**

In spite of the growing economic importance of Accra, most parts of the city are not adequately served by good access roads. The urban transport environment in Accra is characterized by heavy congestion particularly during peak periods, low vehicle utilization rates, weak implementation of traffic management measures, and inadequate facilities for pedestrians and bicyclists, poor road safety arrangements and extremely high accidents rates. Almost 70 percent of person trips in Accra depend on some form of bus as the dominant mode, using less than 15% of the road space; in contrast, private cars and taxis move less than 30 percent of the person trips but occupy over 70 percent of the road space. The transport sector is a dominant source of local air pollution that is responsible for poor health and other negative impacts. (The World Bank, 2008)

In spite the importance of urban public transport in meeting mobility demands of Accra's residents, it operates under financial and management constraints. Accra's inadequate public transport system suppresses the economic and social advantages Ghana's capital city possesses. There is an increasing vehicle population of more than 10 percent per annum, and in 2006 this reached 15 percent. Commuting times from suburban Accra, Adenta, Madina, East Legon, Aburi etc...can be 3 hours or more for transport time to and from work. These terribly high commuting times reduce productivity, increase pollution from exhaust, increase fuel consumption, and negatively affect the health of Accra's inhabitants. (The World Bank, 2008)

Long term transportation planning is drastically needed for Greater Accra, which not only takes into consideration public transportation systems such as Buses, but also links land use to transportation infrastructure. Some efforts have been made, as evidenced by the Bus Rapid Transit (BRT) system which is being used on selected roads in Accra, and some efforts at intersection improvements, traffic networking operations, and enforcement of traffic regulations, but much more is needed. Linking land use to transportation planning, implementing concurrency standards, setting the functional classification of



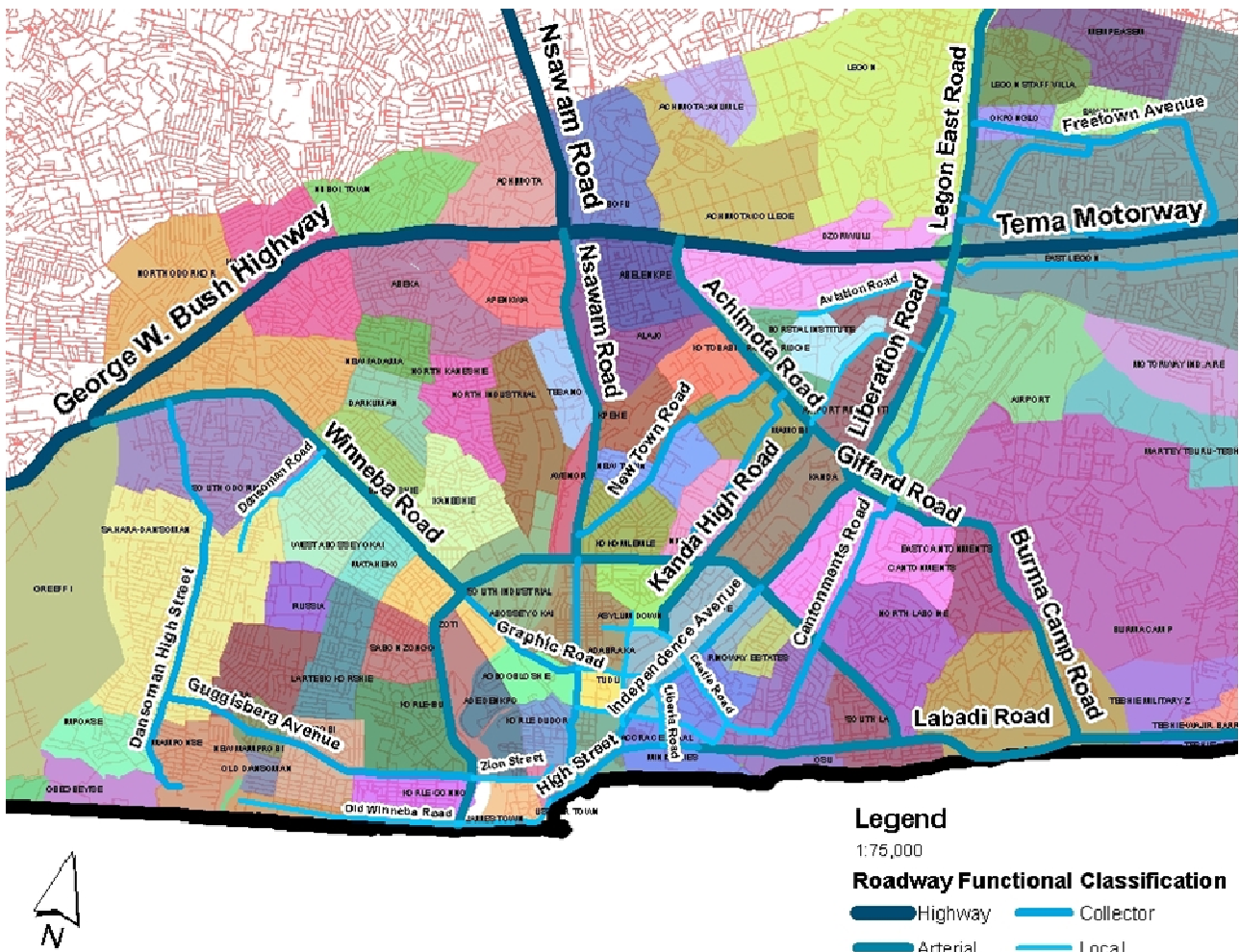

Figure 3.6 Major Roadways of Accra

roadways, and level of service standards for road segments are all needed as part of a comprehensive transportation effort. Hiring and training an effective local police force is also critical to the effort where corruption is rampant and undermines reinforcement of motorist behavior.

The Medium Term Development Plan of the AMA paints a dire picture of the city’s hard infrastructure, especially roads. This is partially due to rapid urbanization and the multitude of associated unplanned settlements which have resulted in more than 400 kilometers of un-engineered roads. Service roads, which are essential for commercial and industrial trips are often intermittent or non-existent, especially in Central Accra, where they are crucial. Overall, the condition of roads in the AMA are listed as more than 45% in poor condition, and almost 30% in fair condition.

Accra is also served by a number of divided major and minor arterials. These include the Tema Motorway, which is supposed to be controlled access, and its extension to Malam, the so-called, soon to be improved George W. Bush Highway. Ring Road, Kwame Nkrumah Boulevard, Liberation Road, Ridge Road, Gifford Road, Kanda Highway are some of the other more significant arterials. High and Oxford Streets as well as Graphic, Spintex, and New Town Roads and Nima Highways are some of the more significant Major Collectors. Some of the more important junctions in Accra are Kwame Nkrumah Circle, Tetteh Quarshie Interchange, Ako Adjei Overpass, King Tackie Tawiah Overpass, and Obtsey Lamptey Circle. With few exceptions, all of these road segments and interchanges are failing nearly all if not all standards for Level of Service.

### Potable Water Supply and Sanitation

Current reports of water supply in Accra indicate that access to public water has decreased from 85% in 1990 to about 60%. Likewise, access to a public sewer for flush toilets is estimated at only 30%. The decaying situation of public water provisions is a combination of inadequate funding for infrastructure (a reported deficit of about \$20 Million USD per year in order to achieve 85% access by 2015) and unbridled, unplanned low density urban sprawl. The result is a disadvantageous economy of scale for water and sewer provisions, as well as the added complexity associated with revenue collection. Furthermore poor planning and improper management has affected the water sector, as evident by a \$20 Million USD World Bank funded wastewater treatment plant which has been constructed but has not been in operation since its completion. The majority of sanitary waste is pumped from the millions of septic tanks located throughout Accra and trucked to Korle Gonno where it is released directly into the Gulf of Guinea.

Problems with water supply for industrial or commercial consumption typically depend on several factors, principally the size of firms or their location. Larger established businesses rarely suffer from shortages because they are located in sectors where water distribution is prioritized or they compensate for service with private storage facilities. On the other hand, for small and medium scale businesses (SMEs), such as hair-dressing salons, car washing bays, and chop bars, intermittent water supply can have a significant, negative economic effect. While there are several strategically located reservoirs and water towers throughout the city, delivery to households and SMEs tend to fall below demand because of inadequate production at the two main water pumping stations: Weija and Kpong – Akuse. It is unclear as to the reason why the Kpong - Akuse station is not used to supply more water to Greater Accra. (AMA, 2004)



Figure 3.7 Inoperable Wastewater Treatment and Septic Truck Disposal



### Stormwater & Flooding

Ambiguities in the responsibility for maintenance of storm drains have contributed to inadequate investment and ineffective service of storm drains in Accra. In Accra, the Hydrologic Service Department of the Ministry of Works and Housing is responsible for the maintenance of large drains and AMA for the rest. Much of the drain cleaning is done as needed and without planning, and in the past, contracts have been awarded to more than one agency for the same area. The Department of Urban Roads had maintained the street side drains as a temporary measure, but in 2002 handed this responsibility over to the AMA, albeit without budget transfers. A proposal to establish a drain maintenance unit was not implemented because the AMA did not want to assume financing responsibility. The result is that storm drains are not properly maintained and many have silted and accumulated refuse to a level where they act as garbage dumps. No Total Maximum Daily Loads have been established in regards to any stormwater runoff, and toxicity levels are well beyond anything appropriate for a humane urban environment.

### Solid Waste

The AMA spends about 37 percent of its current expenses on garbage collection. Residents of Accra generate about 1500 to 1800 tons of solid waste per day. On average only 70% of this waste is collected. A Waste Management Department has been established and empowered, and has seen some improvement with regard to privatization (Zoom Lion is one example).

### 3.2.2 Existing Neighborhood and Land Use Assessment

In many ways, Accra is simply a combination of small villages that have grown over the years, blurring the

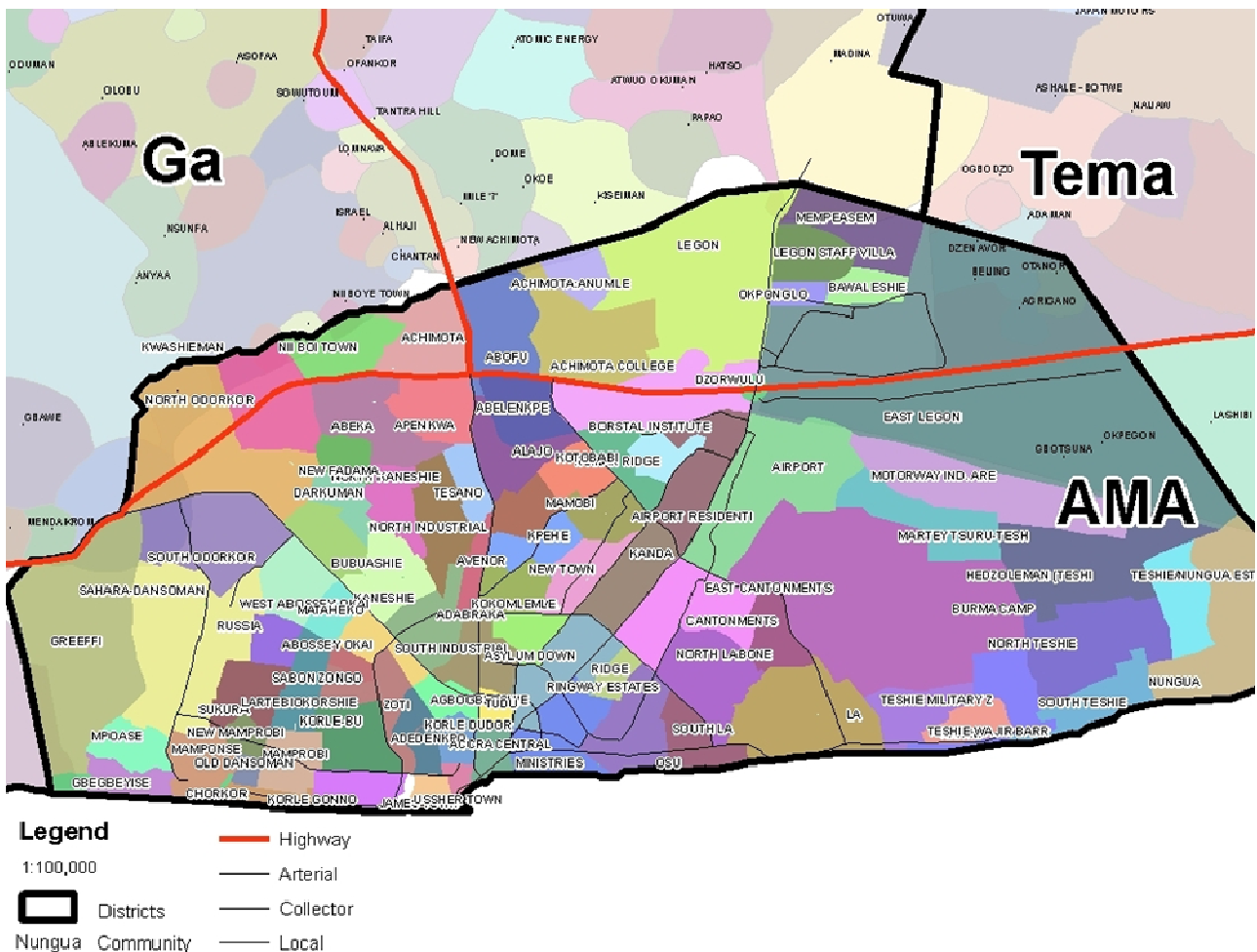

Figure 3.8 Accra's Neighborhoods

lines between where neighborhoods begin and end, and eventually aggregating and synthesizing in becoming what we now know as Greater Accra. Many Accraians still refer to the multitude of neighborhoods that comprise Accra as if they are individual towns or cities, and in fact, most of the neighborhoods retain distinct characteristics. As a good starting point, Greater Accra can be delineated in accordance with those neighborhoods which comprise the AMA, Ga, and Tema districts.

### Industrial Land Uses

Industrial land uses are range in intensity of use from heavy to light. Locations for the most intense industrial land uses are relatively well defined in designated industrial areas. The largest ones are located in proximity to the rail line either along Graphic Road or in the north or south industrial parks. Large scale industrial operations such as Coca-cola, Fan Ice, or Star Beer are located here. While also often just as intense but smaller in size, machine shops and car repair outfits are also located throughout the city. These are often more disaggregated, often fronting one the higher traffic thoroughfares.

### Institutional Land Uses

Numerous institutional uses are located throughout the Greater Accra Region. Two of the larger complexes are the Korle Bu Teaching hospital in Korle Gonno, west of the Lagoon, and the Military Installation on Gifford Road. The national ministries in Accra Central are also a significant agglomeration of institutional uses, including many of the Greater Accra district level offices. The University of Legon, which is located north of the Tetteh-Quarshie Interchange, is also very significant in size. Smaller scale hospitals, police stations, and schools are also spread across the district and region.



Figure 3.9 Industrial Land Uses Located in the South Industrial Area between Obetsey Lamptey Circle and the Odaw River (by





Figure 3.10 Regional Market in Accra: Malam Ata Market on New Town Road in Kokomlemle

### *Commercial Land Uses*

Located throughout Accra are a number of markets which are an agglomeration of multiple uses. Two of the larger regional markets are the Makola Market in Agboghloshie and Malam Ata Market in Kokomlemle. Numerous other commercial districts are located throughout the city, including at Kaneshie and along New Town Road. Commercial activities are also particularly active at Kwame Nkrumah Circle as well as throughout Central Accra. Commercial uses along Osu Road cater more to foreign populations and more affluent Accranaians. This is also true of the Accra Mall, a new development located at Tetteh-Quarshie, as well as the higher quality uses which can be found throughout East Legon to Adjookano and Transaco Village. Still, pretty much throughout Accra, small scale commercial uses are found everywhere located in kiosks or converted freight containers (TEUs) and very often located within street right-of-ways.

### *Residential Land Uses*

Housing types in Accra can be characterized more or less in terms of the size and value of the building, as well as its density. The highest quality and most expensive housing, which is generally for foreigners and only the most affluent Accranaians, are single family detached dwellings located within planned residential subdivisions with gated access by a private street. The next step in quality of housing are single family homes located on subdivided plots with direct access by a public road. While not part of a gated community, these types of homes are generally accessed via a gate and surrounded by a 6 to 8 foot wall which is centered on the property line. While these may be inhabited by foreigners, it is more common to find families with more long standing ties to the community, or perhaps second generation immigrants (Lebanon, Russia in some instances, and elsewhere). By far the most common type of housing in Accra is the compound structure, which is typically a combination of rooms, around a common open area. Like the detached home, the quality of housing is often correlated to its access. Higher quality compound structures can be found and accessed via a public street or from a short walk, while some of the lower quality compound structures are only accessed via footpath, insulated and surrounded by numerous other compound structures, which likely comprise a larger slum like neighborhood.

Compound structures account for almost 70% of the housing stock in Accra, while those living in separate

houses or semi-detached homes comprise about 15% of all dwelling types. Flats or apartments comprise 9% of the stock. More than 50% of all households in Accra rent spaces located within a compound structure, while only about 25% own their home. Of the compound houses located in Accra, 54% are comprised of a single room, while 31% are comprised of two rooms. The mean area occupied by a household in Accra is 42.6 square meters. Approximately 85% of all households in Greater Accra have access to water from a supply pipe, either indoors or in proximity to their domicile. Almost 90% of all households in Accra have access to electricity for lighting purposes, but still more than 50% use charcoal for cooking, while only 35% use natural gas. Only 40% of Accranaian households report their garbage is collected, while more than 42% dispose of their garbage in a 'public dump' and nearly 10% 'dump it elsewhere.' Additionally, only 30% of Accra's households report the use of a flush toilet, but it is unclear if these flush into a sanitary sewer system leading to a wastewater treatment facility or a combined sewer, which drains into the roadside storm sewers and eventually into open canals, the water table and towards the Gulf of Guinea. (GSS, 2008)

### High End Developments and Properties

Within the last two decades Accra has gone through a far reaching social and economic transformation resulting in an increasing fragmentation of urban residential space. As foreign direct investment led to more foreign nationals requiring a residence in Accra, demand for private enclaves which have been clearly demarcated from the surrounding environment have been demanded. This is partly due to the demand to create microenvironments within the city which are more akin to western style housing (or eastern in some cases) as well as problems associated with widespread land law cases, which have seen anywhere from 15,000 to 60,000 cases pending in the recent past. Individual units, depending on the gated subdivision, generally range in price from 30,000 to 460,000 USD (the high end being the homes located in Transacco Valley). Once these 23 gated communities are all completed, the total number of units will be 3,572 houses and 72 apartments or about 3% of the current stock.

### Detached Homes, Flats and Apartments

While the majority of Accranaians continue to reside in compound structures, Single Family Homes or

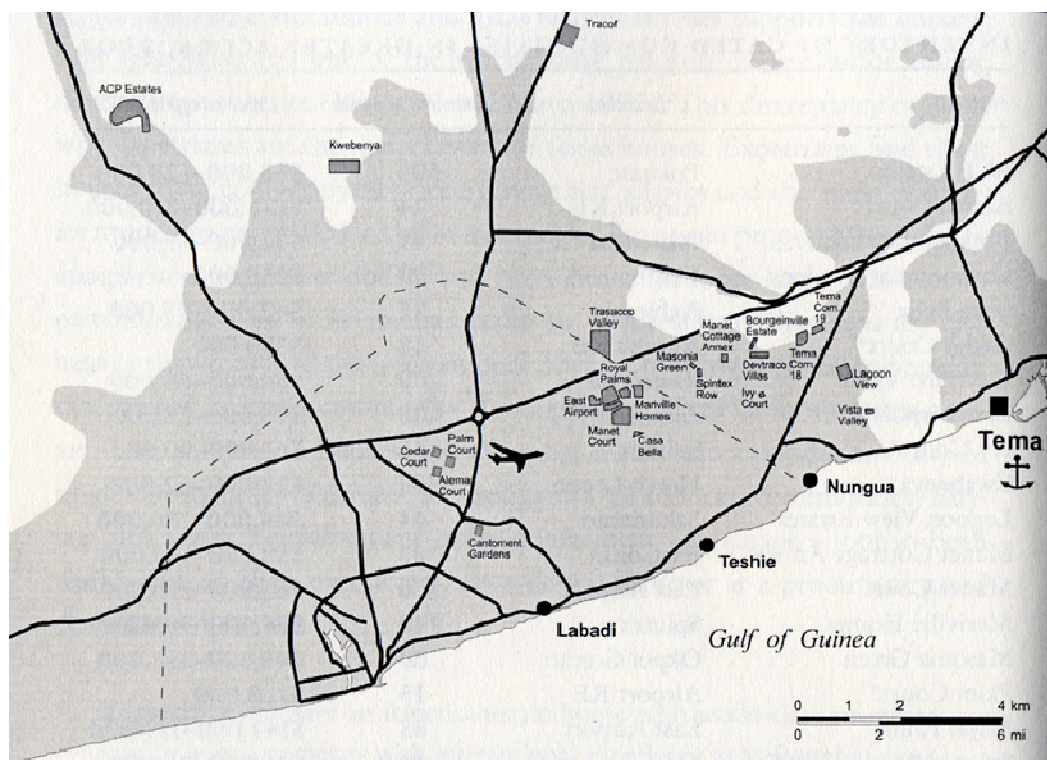

Figure 3.11 Gated Communities throughout Accra (from Grant)



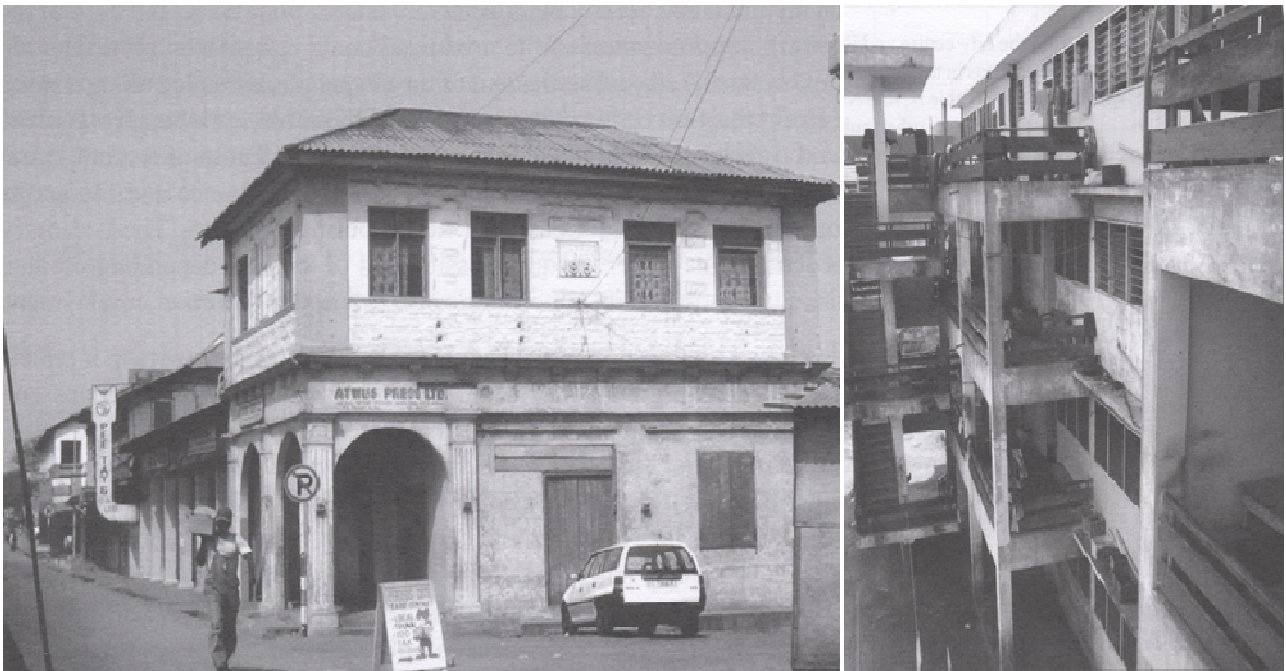

Figure 3.12 Detached Home and Flats typical of Accra (from Bertrand)

detached homes have gained more and more popularity over the recent years. Census results indicate that 68,340 new houses were built in Accra since 1984 with the largest increase being in semi-detached homes as well as flats and apartments. The value of single family homes is typically dictated by the neighborhood and the public services which are provided. Single family homes in East Legon, Cantonments, Osu and Airport Residential are some of the most expensive properties in Accra. While the normally access paved public streets, they also also typically walled and accessed via a gate. Single family homes in neighborhoods such as Kokomlemlé or La are generally second tier properties which or normally not surrounded by a wall. The surface quality of the access road will also have a large impact on the residential value of the property.

### Compound Structures

By current accounts compound structures account for anywhere from 45% to 70% of the housing stock in Accra, and are the most dominant type of residential housing structure. Due to the popularization of western styles of housing, this type has shown a decrease in popularity since 1984. Part of this decrease in popularity was often inability to sell or transfer the property due to the associated idea that property was the birthright succeeding generations, rather than being at the disposal of the living. A compound house normally consists of many small rooms off a private internal courtyard. This open, unroofed courtyard leads directly to household living spaces directly from the courtyard or sometimes by a porch or veranda. Compound dwellings can also vary in size, with most being single story structures, but multi-story buildings also exist.

### 3.3 Greater Accra's Human Geographic Patterns

Ghana is subdivided into 10 Regions and 170 Districts, the Greater Accra Metropolitan Area spans two of these regions (Greater Accra and Central Regions) and five of these districts (AMA, Ga East, Ga West, Tema, and Awutu-Senya). Complicating political subdivisions further, the Greater Accra Region is comprised of 2 Metropolitan Assemblies (Accra and Tema, both which have populations of more than 250,000 inhabitants) and 6 Municipal Assemblies (Adenta, Ashaiman, Ga East, Ga West, Ledzekuku-Krowor, and Weija which have populations of more than 95,000 inhabitants). Additionally, the Municipalities of Kasuo and (to a lesser extent) Nsawam have been absorbed into sprawling Accra. Both

are politically located in different regions (Central and Eastern Regions respectively) with different seats of Regional and District administrative authority, but physically and economically are connected to Accra. (Ministry of Local Government, 2009) These District Assemblies which comprise the Greater Accra Metropolitan Area have been part of the decentralization process enacted as part of Law 207 (PNDC) in 1988. In 1993, the Local Government Act granted District Assemblies (DAs) the power to: (i) exercise political and administrative authority in the District; (ii) provide guidance for district inhabitants; (iii) supervise all administrative authorities in the District; (iv) and assure overall development of the District including development of basic infrastructure, provision of municipal works and services, and management of human settlements and the environment. (The Republic of Ghana, 1993)

### *Local Government Decentralization in Accra*

Since the fight against poverty introduced a social dimension to structural adjustment, the community ideal has influenced urban development which has been promoted and financed by international donors in African towns. The intent of this ideal has been to plan for a decentralized, socially regulated, urban fabric which is highly disaggregated, to the block and even plot with the intent to make public administration of policy (for example urban taxation) more efficient. These “Urban Projects” of the World Bank have assumed the virtues of all that is local, while highlighting decentralization measures, community upgrading, and local participation. Part of the intent is to introduce into the willingness and capacity of townspeople to pay for their services, and also points to the residential anchoring of urban dwellers as the best guarantee of mobilizing these necessary resources. In this framework, landowners are considered the best settled and most solvent taxpayers, thought to making up a stable territorial pattern, with a clear identity on the very local scale of intervention and of urban markets. (Bertrand 2005)

US\$	Accra (2003)	Cotonou (2003)	Dakar (2002)	Ouagadougou (2002)	Porto-Novo (2003)
<b>Current revenues</b>	<b>4.5</b>	<b>23.8</b>	<b>15.0</b>	<b>16.0</b>	<b>14.0</b>
Taxes	1.4	12.0	12.0	8.3	1.8
Fees and rent	1.2	1.6	2.2	2.0	1.8
Other revenues (grants included)	1.8	7.7	0.7	1.0	9.4
Income n-1	-	2.6	-	4.6	1.0
<b>Current expenditures</b>	<b>4.3</b>	<b>17.8</b>	<b>11.0</b>	<b>12.7</b>	<b>10.4</b>
Personnel	1.3	2.8	4.0	2.8	2.3
Other current expenses	3.0	15.1	7.0	7.9	8.1
Interest	-	-	-	0.2	-
Deficit n-1	-	-	-	1.8	-
Saving (income)	0.1	6.0	3.9	3.3	3.6
<b>Capital revenues</b>	<b>2.6</b>	<b>6.7</b>	<b>1.8</b>	<b>5.3</b>	<b>3.6</b>
Saving used	-	6.7	1.8	-	3.6
Grants from State	2.2	-	0.0	0.0	-
Other grants	0.4	-	-	-	-
Loans	0.0	-	-	-	-
Other revenues	-	-	-	5.1	-
<b>Capital expenditures</b>	<b>2.6</b>	<b>6.7</b>	<b>1.8</b>	<b>4.9</b>	<b>5.3</b>
Reimbursement of debt	-	-	-	0.2	0.1
Equipment	2.6	6.7	1.8	4.6	5.3
Other expenses	-	-	-	0.2	-
Result	0.0	-	-	0.3	-1.7
<b>Total revenues</b>	<b>7.1</b>	<b>30.6</b>	<b>16.8</b>	<b>21.2</b>	<b>17.6</b>

Figure 3.13 Comparison of Resources and Expenses from Five African Cities (from Farvacque-Vitkovic et al.)

In the more specific context of Accra, at the end of the 1980s, district assemblies were given new powers and means as part of the decentralization framework, while during the last decade local government has evolved towards election and designation of assembly members and Unit Committees. This transformation has also brought to the surface older problems, notably in the relations between indigenous people and outsiders, the former using customary procedure as a defense against migrants' demographic pressures. The real objects of pressure and identity manipulation at the local level, especially among the impoverished populations are limitations upon: the access to land, the influence of community opinion, neighborhood representation and municipal lobbying. Urban development in Accra has overlooked the questions regarding tenant participation when addressing poverty reduction and the result of the local "good governance" concept has concealed disintegrating social relations in the rental sector. One cannot overlook that the aggregation of local governments comprising Greater Accra, which have been both required and promised by international donors, has largely contributed to the disenfranchisement of migrant populations and remains an obstacle to poverty reduction. (Bertrand 2005)

### Local Government Funding Mechanisms

District Assembly revenues are largely made up of transfers from the central government or donors. Of the Greater Accra DAs, approximately 84% were transfers, while only 16% was generated from internal revenues such as rates, fees and land revenues. Still while all DA revenues represent about 5 percent of central Government revenue, the central government transfers only 4.5% of its budget to the DAs. In 2004, DAs spent 78 percent of their total budgets on investments while only 11 percent was for personnel salaries. A comparison of the municipal finances of five West African cities shows a sharp differentiation especially between Accra and other capitals of the Region. A recent study estimated that an investment of \$80 USD per capita over more than 300 square kilometers would be needed to upgrade basic infrastructure services in Accra. (The World Bank, 2008)

When comparing the five largest DAs in Ghana data reveals that they represent 44% of the total current internally generated revenues, but only 10% of the grants. This is a testament to the fact that revenues per capita in large DAs are low compared to the average, with Accra having among the lowest revenue per capita of all the cities. In addition to receiving a disproportionate share of the grants from the central Government, internally generated revenues have also been very low in Accra, averaging around 15% of

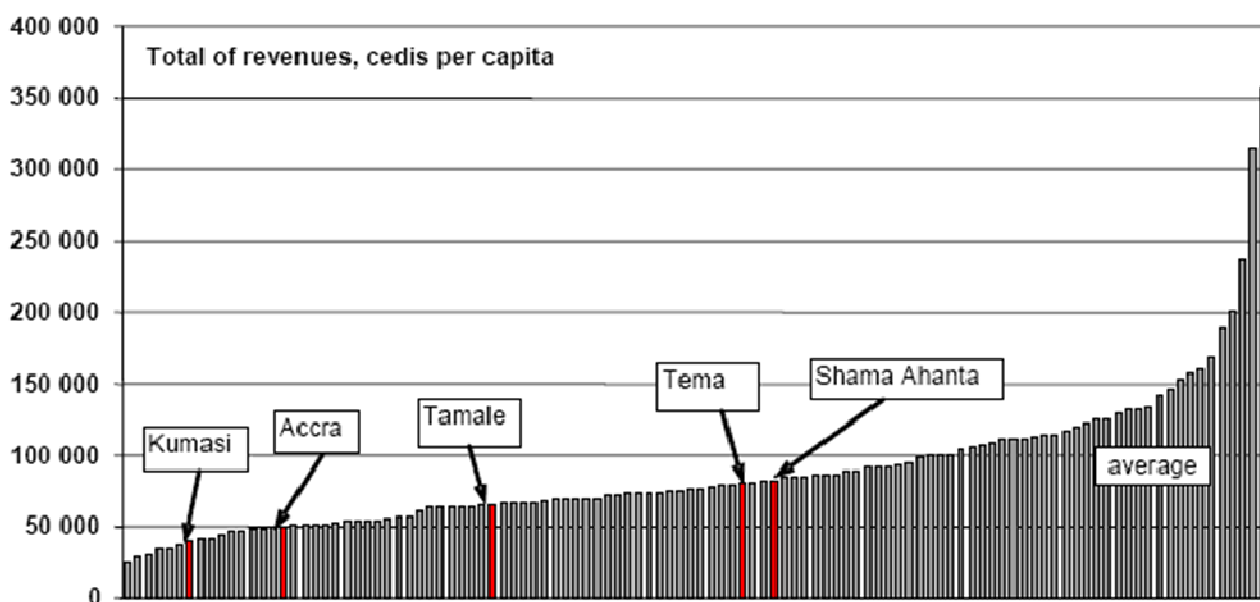

Figure 3.14 District Assembly Revenues per Capita (from Farvacque-Vitkovic et al.)

the total budget. Also, the formula for the allocation of the District Assembly Common Fund disproportionately weights the smaller DAs. For example, an average district represents 0.72 percent of the total population of Ghana, and usually receives the same proportion of the Common Fund. But the Accra Metropolitan Assembly (AMA) represents nearly 9% of the population, but receives a bit more than 1% of the Common Fund. Clearly this distribution favors the small DAs, with the statistical distribution being diametrically opposed to the population size. In large countries, transfer mechanisms tend to favor large cities as they are most often the providers of diverse and expensive services. However, under the existing Ghanaian fiscal transfer system, the resource transfers favor rural districts and small towns. (DACF 2005)

The situation is similar for HIPC grants, which also follows a distribution formula similar to the DACF. For example compare disbursements to the Upper West Region which received about 135,000 Cedis per capita, while the Greater Accra Region received closer to 60,000 Cedis per capita. Again rural areas are being favored over urban areas, and the northern regions over the southern ones. Another illustration of this preference are the grants to Tamale, the poorest metropolitan area, which receives the same amount per capita as Accra due to substantial grants. Additionally, other donor support is concentrated on half the Districts, with large cities such as Accra receiving close to nothing. (The World Bank 2008)

### Land Valuation

The Land Valuation Board carries out the valuation of properties in each of the districts (AMA, Ga, Tema, etc...) and prepares a Valuation List which is a list of all the assessed properties and their values. This taxation mechanism is called the Property Rate and it is the only tax that is based entirely on property, with its valuation method based on the replacement cost. Land in Greater Accra is a vastly undervalued fiscal resource as well as an untapped instrument for potential sustainable land development. Likewise,

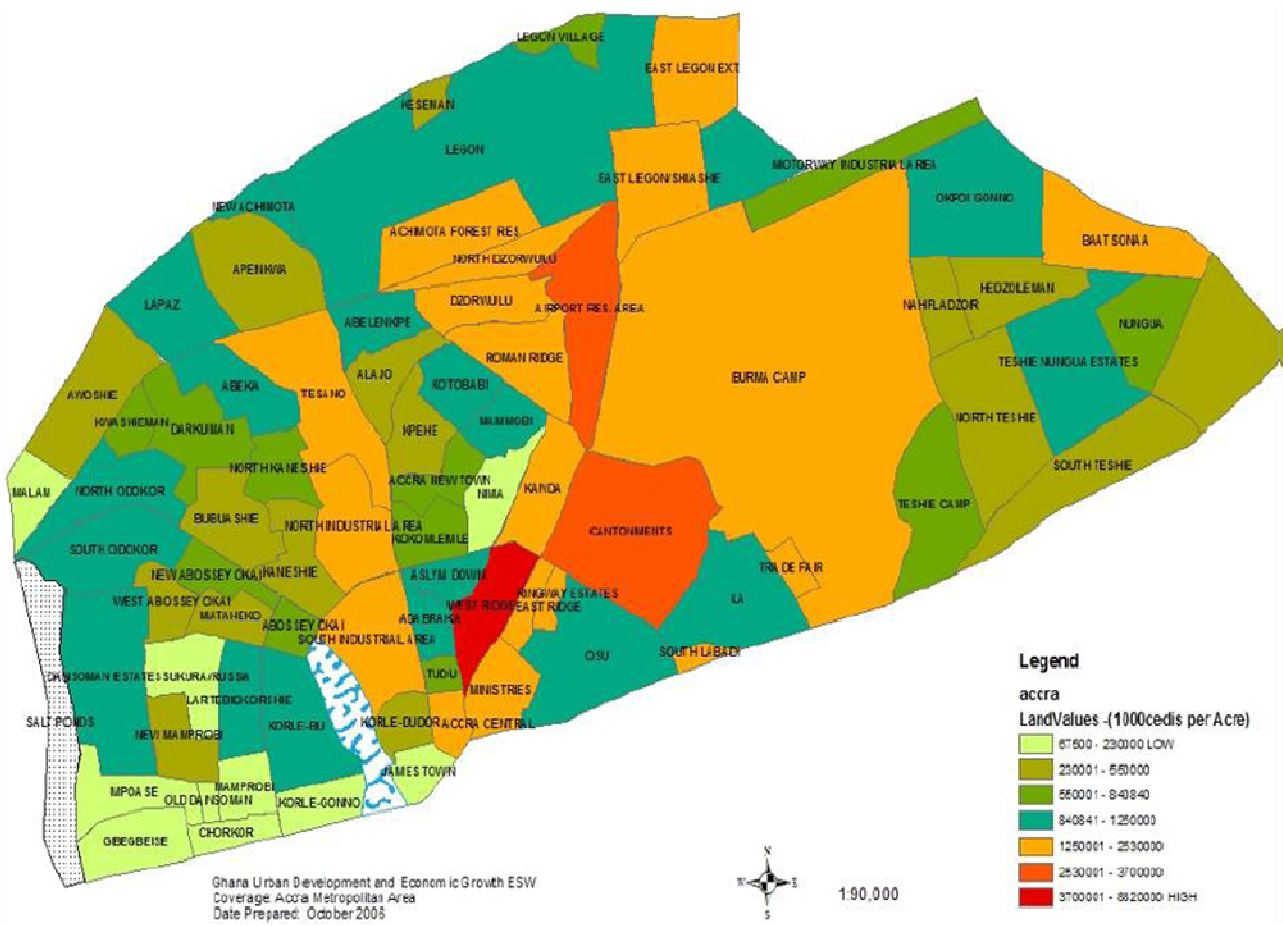

Figure 3.15 Land Values throughout Accra (from Farvacque-Vitkovic et al.)



property taxation is a potentially important tool for the Accra Metropolitan Assembly, requires drastic revision from a simple method for generating revenue to one that serves specific land management goals and objectives. (The World Bank 2008)

Revenue generated from property in Accra is no better than 2 GHC per capita, which lends serious doubt as to whether the resources yielded by the property rates are commensurate with the cost of administering the assessment of individual Property Rates in order to create the Valuation List. Determining the replacement cost of all the properties in a district is extremely time consuming, and becomes even more so when valuing specialized properties such as plants and machinery for very large industrial buildings. A better approach is to base property taxation on the open market value. This has the advantage of discouraging speculation by weighing the tax more heavily on vacant lands and would also capture land values which are not the result of landowner investment decisions (unearned increments to land value). Levying based on the open market value would make the assessment faster and less cumbersome with the ability to process mass valuations and limit the number of man hours need from a Regional Valuation Board which has been rife with corruption. (GSS, 2008)

### 3.3.1 Economics

While there are no official statistics on the contribution of the overall urban economy to Ghana’s GDP, it may be estimated, based on the share of industry and services (which are mainly urban-based) that the urban economy contributes about 60 percent to GDP. (GPRS-II, 2005) The AMA estimates that Accra’s total economic activity accounts for at least 10% of Ghana’s GDP, with manufacturing activities contributing to over 50% of value added. This implies that focusing on Ghana’s urban economies, especially Accra, to add more value to their agricultural output is critical to achieving the nation’s aim of achieving middle income status. Additionally, nearly 80% of all Foreign Direct Investment in Ghana were investments located in the Greater Accra Region (approximately \$160 Million USD in 2005 alone), further emphasizing the importance for urban development research.

Adequate urban infrastructure and services, a supportive urban policy framework at the AMA, Greater Accra Region, and National levels, and good institutional capacity are essential for the growth of the urban economy. Infrastructure investments serve to promote an enabling environment for micro, small and medium enterprises (MSMEs). However, in Accra, inadequate infrastructure facilities and public services hinder the formation and growth of firms by increasing the cost of doing business, limiting access to markets, and reducing efficiency. Urban productivity is also hampered by low-density urban sprawl, which

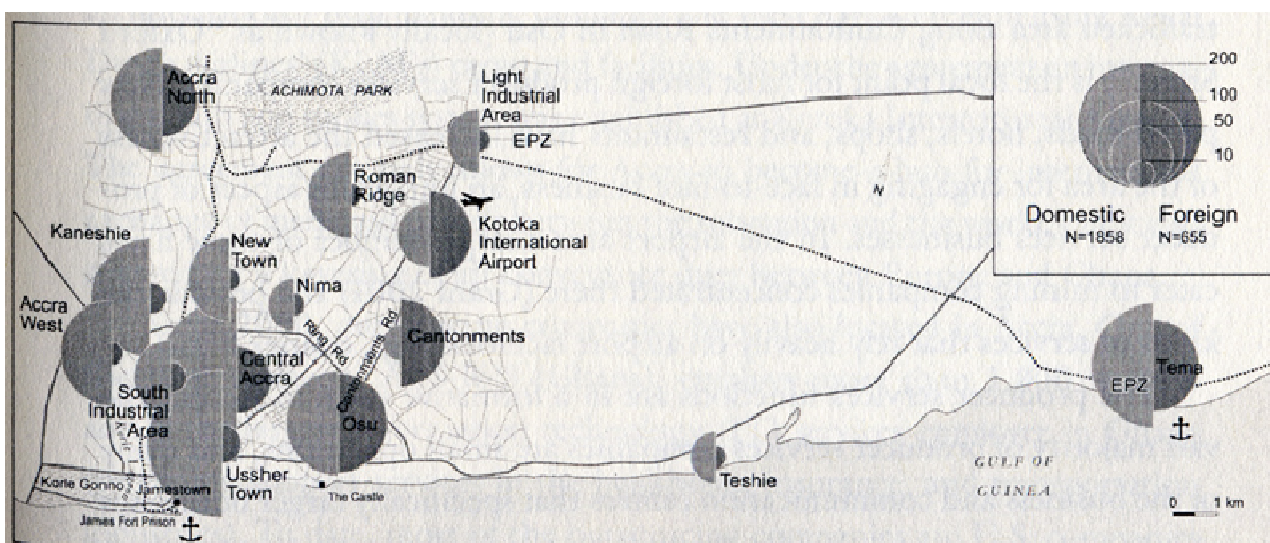

Figure 3.16 Foreign and Domestic Businesses in Accra (from Grant)

increases the cost of infrastructure and commuting. Concentrations of small and micro enterprises in urban areas provide thousands of jobs and serve as incubators for the growth of firms, but these lack most basic services and are at risk from ill-conceived location schemes. In the medium to longer term, the development of industry will be constrained unless measures are taken to facilitate the availability of land and services for industries. Emerging enterprises with premises and sufficient technical knowledge and the more sophisticated technologies with dynamic growth potential (such as a welding shop, for example) are more likely to have a direct impact. Enterprises whose operations are closer to subsistence than to the market economy need to be considered separately policy wise due to an unlikelihood for growth potential and wealth accumulation. At the household level, the productivity of the urban poor is kept low by among many things, deficiency in basic services, especially road access and sanitation. (Camilleri, 2006)

### Labor Force and Earnings

The informal sector accounts for 40 percent of the national income, with the majority of this earned in urban areas. In Accra, the informal sector, which is predominantly comprised of self-employed workers often employed in retailing or light volume trading services, accounts for somewhere between 45% and 80% percent of the total labor force. Of the approximately 3 million Accraians, 60 % of all persons between the ages of 15 and 64 are economically active, while this number increases to 80% of males and 70% of females between the ages of 25 to 64. (GSS, 2008) Most have either wage employment (males nearly 50%) or are self-employed without employees (females a bit more than 50%). The main occupation listed for 45% of all persons between 15 and 64 was either service & sales or craft and related trades. An economic breakdown of employment by sector also reinforces the significance of the informal sector with more than 30% employed in the trade industry, and 16% in manufacturing. It is estimated there are more than 440,000 businesses spread amongst the manufacturing, trading, and “other” sectors. Interestingly, female operated businesses outnumbering male owned ones almost 3 to 1, thus emphasizing the importance of household enterprises. Agriculture, primarily fishing is also a significant contributor to household income in Accra. (GSS, 2008)

Greater Accra has an average annual income of 1,529 GHC and a mean annual per capita income of 544 GHC. In terms of household sources of income, the majority of money brought into Accra’s homes is from wage income (almost 60%) while non-farm self employment accounts for about 25%. Those working in the financial services, real estate, and electricity sectors consistently worked more than 40 hours per week. Public administration, education, and health and social work also received more than 35 hours per week of work. The financial and real estate industries paid the best, with employees receiving more than 1.5 and 1.25 GHC per hour respectively. Likewise, those classified as legislators/managers or professionals

Current activity rate by sex, age group and locality (percent)

Sex	Age-group	Accra
Male	7 – 14	0.4
	15 – 24	18.3
	25 – 44	82.2
	45 – 64	80.4
	65+	25.8
	All	46.2
Female	7 – 14	1.7
	15 – 24	22.0
	25 – 44	60.6
	45 – 64	70.6
	65+	9.8
	All	41.6
Both sexes	7 – 14	1.0
	15 – 24	20.3
	25 – 44	75.8
	45 – 64	75.7
	65+	17.2
	All	44.8

Distribution of the currently employed population aged 15 - 64 years, by industry group, locality and sex (percent)

Industry	Accra		
	Male	Female	All
Agriculture	20.8	16.6	18.6
Fishing	1.3	0.2	0.7
Mining	1.3	0.6	0.9
Manufacturing	16.3	16.9	16.6
Electricity	0.9	0.1	0.5
Construction	6.8	0.2	3.5
Trade	18.4	42.1	30.4
Hotel and restaurants	1.0	5.1	3.1
Transport and communication	10.4	1.1	5.7
Financial services	1.4	0.3	0.8
Real estates	3.4	0.7	2.1
Public administration	5.5	1.8	3.7
Education	5.8	5.3	5.6
Health and social work	1.6	1.7	1.7
Other community services	4.2	6.4	5.3
Activities of private households	0.7	0.7	0.7
Extra territorial organizations	0.2	0.0	0.1
All	100.0	100.0	100.0

Average basic hourly earnings (GHC) in main job by sex and industry of the employed aged 15 years +

Main Industry	Earnings		
	Male	Female	All
Agriculture	0.49	0.29	0.41
Fishing	1.18	0.96	1.16
Mining	0.92	0.44	0.80
Manufacturing	0.59	0.66	0.63
Electricity	0.83	0.48	0.77
Construction	0.63	0.30	0.62
Trade	0.66	0.56	0.59
Hotel and restaurants	0.81	0.61	0.64
Transport and communication	0.48	0.61	0.49
Financial services	1.07	0.98	1.04
Real estates	1.26	0.74	1.18
Public administration	0.70	1.03	0.78
Education	0.95	0.74	0.87
Health and social work	1.00	0.88	0.94
Other community services	0.65	0.60	0.67
Activities of private households	0.50	0.24	0.38
Extra territorial organizations	1.33	0.00	1.33
All	0.61	0.60	0.55

Figure 3.17 Activity, Distribution, and Earnings of Accraians (from GSS)

expectedly received the highest hourly earnings, also 1.5 GHC or more. Comparatively, those working in the services and trades made closer to 0.5 GHC per hour. Remittances are also significant, accounting for almost 10% of all household income in Greater Accra, particularly amongst mothers with children living abroad. (GSS, 2008)

### 3.3.3 Demographics

The report of the fifth round from the Ghana Living Standard Survey (GLSS) indicates that approximately 921,000 households are located in the Greater Accra Region, and that the mean size for these households is 3.4 persons. This 2005 estimate is down considerably from the 2000 census of 4.6 persons per household, but should be carefully considered in terms of its accuracy. While the neighborhoods of Osu, Cantonments, and East Legon reflect a typical subdivision, Kokomlemle, Nima, New Town, La, Dansoman, Nungua, Madeina & Adenta, and many others are better examples of the typical neighborhood that comprises this largely residential urban metropolis. The midyear census for Greater Accra as well as the GLSS 5 estimate the population for Greater Accra between 3.1 and 3.7 million persons and, estimates the Greater Accra Metropolitan Area, which comprises the AMA, TMA, and their surrounding urban areas, at 2.6 million. These population estimates should also be carefully considered in terms of its accuracy.

Most of the heads of households in Accra are male and more than 40 years old, while 65% of all households are inhabited by a married couple. Accra's population is young with a large segment of the men being under 30 years old (more than 30%) and women under 25 years old (more than 28%). Most Accranaians trace their ethnicity to Akan (Asante or Fanti) or Ga lineages (more than 75%), while Ewe ancestral lineages (generally from the Volta Region) comprise about 14%. Also, more than 80% of all households profess a Christian denomination, the highest concentration in Ghana, while a significant and noticeable Muslim population is also reflected in the statistical count (about 12% of households). Unlike more rural parts of Ghana, Accranaians neither practice traditional African religions nor consider themselves non-believers in statistically significant numbers. (GSS, 2008)

A survey of the proportion of households owning various items revealed interesting characteristics with implications for the future. Less than 2% of all households in Greater Accra owned an air conditioner, while about 50% owned either a kerosene, electric or gas stove. Additionally a bit less than 50% owned a refrigerator. Only 6% of the households in Accra owned a computer and less than 2% owned a washing machine. While 73% of all households in Accra possessed a television, only 10% owned an automobile and 5% a bicycle. The average annual expenditure of families dwelling in a compound house was 2,263 GHC per year, while separate houses and semi-detached houses had expenditures of 6,835 and 3,830 GHC respectively. Survey results indicated that flat apartment expenditures were 4,147 GHC per year. (GSS,

**Households, by type**

Type of dwelling	Accra (GAMA)
Separate House(Bungalow)	8.5
Semi-detached house	6.8
Flat/Apartment	8.9
Room(s) [Compound House]	53.9
Room(s) [Other Type]	15.6
Several Huts/Buildings [same compound]	2.8
Several Huts/Buildings [different compound]	0.0
Tents/Improvised Home	2.3
Other	1.4
All	100.0

**Household heads, by ethnicity (percent)**

Ethnicity	Greater Accra
Akan	39.3
Asante	10.7
Fanti	10.1
Other Akan	18.5
Ga-Dangme	37.7
Ewe	13.9
Guan	1.8
Gurma	0.4
Mole-Dagbani	4.8
Grusi	1.0
Mande	0.5
All other	0.7
Total	100.0

**Household heads by religion**

Religion	Accra (GAMA)
Christians	81.6
Catholic	9.3
Anglican	3.8
Presbyterian	14.0
Methodist	8.1
Pentecostal	31.4
Spiritualist	3.0
Other Christian	12.0
Islam	11.5
Traditional	0.5
No Religion	6.1
Other	0.3
Total	100.0

Figure 3.18 Households by Type, Ethnicity and Religion (from GSS)

2008)

### Household Mobility

According to the social and territorial dynamics of the metropolis, urban development is a dialectical process between the residential mobility of individuals and households and the anchoring effects resulting from capital improvements. On the regional scale, one cannot study rehabilitating Accra without examining the constraints and opportunities presented by housing and employment markets. Where an individual lives and works affects the redistribution of populations through a combination of inward and outward movements, and recomposes local territorial groups according to criteria of accessibility and transport services. Since independence, several studies have considered migration in its classical sense, as a one-way, definitive movement, but there has not been a study of residential mobility in the center of Ghana's principal labor pool and property market. (Bertrand 2005)

To establish what differentiates the mobility of the inhabitants of Accra, within the perimeter of the capital region, several demographic and socioeconomic indicators were recorded as part of a study by the Institut de Recherche pour le Developpement (IRD) in the Centre Population et Developpement (CEPED) at the University of Paris. The purpose of the study was to measure mobility and to examine variations of its intensity in Accra. To ensure representativeness throughout the Greater Accra Metropolitan Area, seven survey zones were chosen: Old Teshie, Lagos Town (New Town), New Fadama, New Gbawe, Tema City 5, Ashaiman, and Dodowa. The choice of neighborhoods was based on the spatial configuration of Accra and the history of its settlements. The primary attributes taken into consideration when choosing these 7 communities were: distance to center, type of housing stock (compound house, self-contained house, and flats), socioeconomic level of households, and indigenous versus migrant populations. Bertrand and Delaunay established several demographic and socioeconomic variables as well as religious and tribal affiliation indicators in order to differentiate the Accranaians' mobility.

### The Affect of Time

From the perspective of studying residential mobility, we can assume that when a person decides to move, for whatever their reason, that decision reflects that the value of the new location is higher than the hazard of moving. As time passes, and individuals grow in age, stability becomes more of the norm and the tendency to move diminishes. Bertrand's study in Accra generally found this to be the case. The

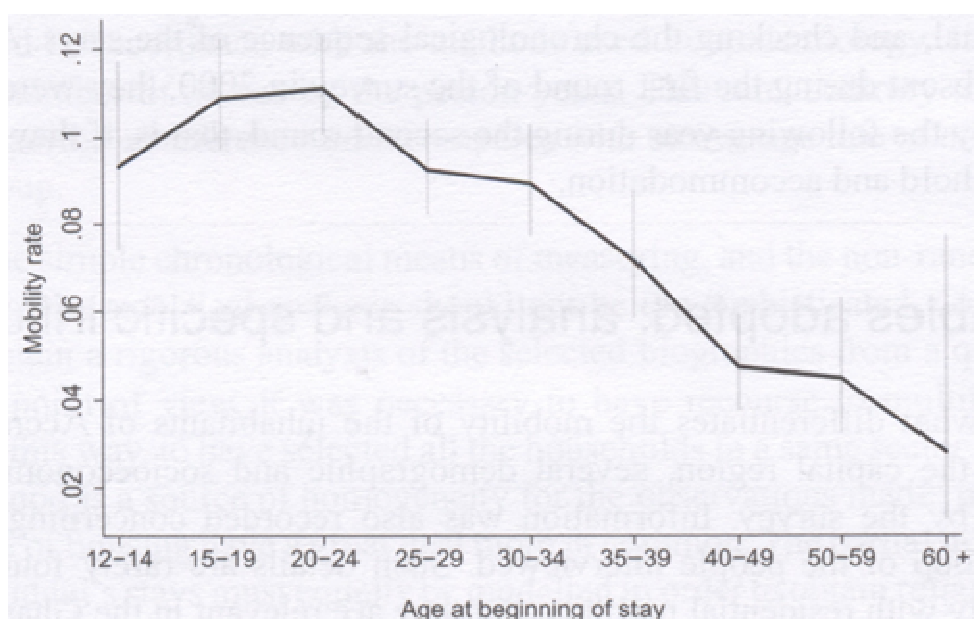

Figure 3.19 Mobility by Age (from Bertrand)

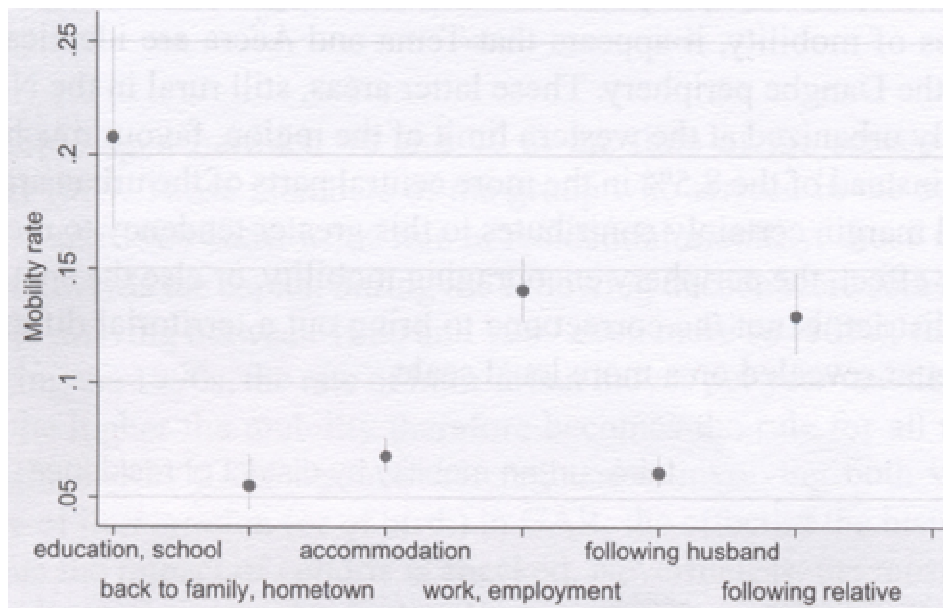

Figure 3.20 Mobility by Reason (from Bertrand)

frequency of moving increases until the age of about 25, which coincides with the search for work and accommodation, and the settling of an independent household; then residential mobility rapidly decreases after this age. It is also important to identify that different cohorts are more mobile than others at the same moments in their lifetimes, a reflection of the fact that Accra as a city is also ever evolving and affecting intra-urban residential mobility. For example, 20 – 24 year olds in the year 2000 have a 17% probability of choosing to move over the hazard presented by moving as compared with a 11% probability observed retrospectively for the sum of all other cohorts aged 20 – 24. This increase in the likelihood of residential mobility may depend on the historical context of the city at that precise moment. Permanent settling seems to be becoming more difficult, likely due to expanding and overpopulating the oldest urbanized areas as well as increases in salaried work which creates incentive to relocate.

#### Location and Reason for Move

According to the study, the profiles for Metropolis Accra and Tema have similar mobility rates, while Ga and Dangbe west, districts which are more so in the urban periphery, also have similar rates. These latter areas, or more recently urbanized at the western limits of the region, tend towards much higher mobility, due to a concentric effect with their location at the peripheral suburbs encouraging mobility. With regard to the reason for a move, short stays tend to be motivated by education, while professional reasons precipitate longer stays. Three reasons lead to undifferentiated duration of stays: the return to the hometown or to the family, the simple change of accommodation, or the accompaniment of a husband.

#### Individual Characteristics

Bertrand also developed the respective mobility based on a number of individual characteristics indicated as part of their survey. Regarding sex, residential mobility clearly indicates that men are significantly more mobile than women. The prominence of male mobility was particularly prominent in Upper Dodowa. Marital status had a less prominent indication of mobility, with single people apparently making shorter stays as compared with married and divorced persons. Interestingly, divorced persons were significantly more mobile than separated individuals. Separation is particularly characteristic of poor levels, typical of the Ga in Teshie and the Shai in Dodowa, who marry more often within their community, where they can benefit from usufructuary rights. Level of education is a strong discriminating factor in mobility, with mobility rates steadily increasing as educational status progresses towards more advanced education.



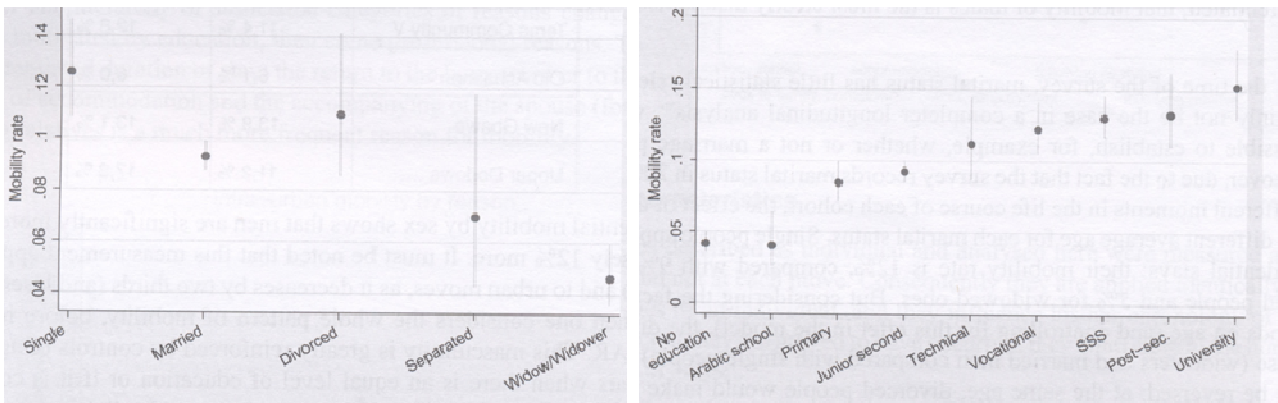

Figure 3.21 Mobility by Marital Status and Education (from Bertrand)

Professional status can also provide some details as to the residential mobility of an individual, with public sector workers having the highest rates (11% with a move per year). Mobility can also be ascertained in accordance with ethnic group and religion, with Akan and Ewe groups showing the highest incidences of choosing a new residential location, while Northerners and those from other West African origins illustrated lower rates. In terms of mobility in accordance with religious affiliation, traditional cults showed the lowest rates, while those who did not attend church or described themselves as having no religion had the highest chance of relocating. Moslems, Catholics, Protestants and Pentecostal/Charismatics had rates ranging from 6% to 11% respectively.

### Households and Housing Types

In general individuals in single person households were less mobile than those in households composed of several people, with the frequency of moving decreasing when a household comprised three or more persons, but increased when nine or more individuals occupied a domestic unit. The considerable rise in the mobility of spouses and children is also likely when compared to the head of household. Compound housing often brings together families of modest incomes or even living in poverty, while flats and self-contained houses are reserved for the middle class. Mobility is higher amongst flats and self-contained houses while occupants of compound houses tend to settle more or may be restricted by the land and property market in Accra.

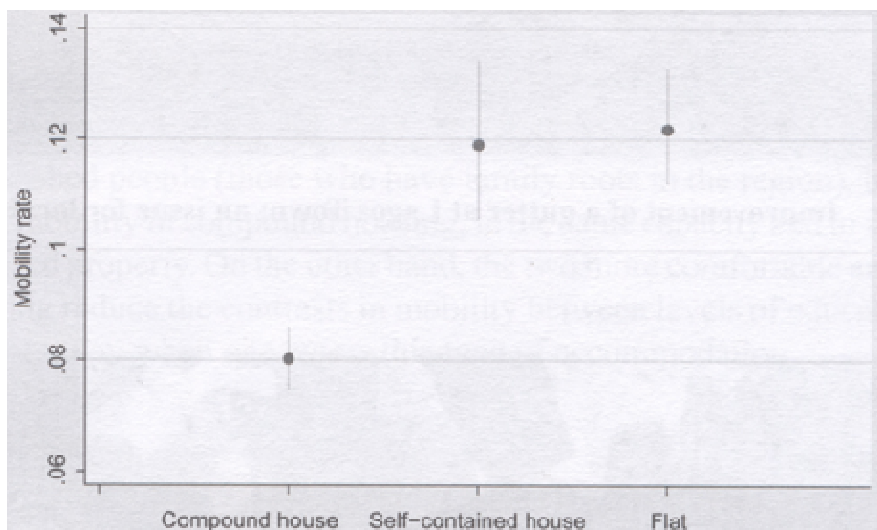

Figure 3.22 Mobility by Housing Type (from Bertrand)

## **Chapter 4**

# **Electricity Infrastructure and Demand in Accra**

## 4.1 Powering Megacities in the Developing World

Efficient power supply and energy demands will be central questions in the 21<sup>st</sup> century and beyond. Mankind's energy consumption is rising continuously and presents enormous challenges for climate protection and energy security. The International Energy Agency (IEA) predicts that worldwide energy consumption in the year 2030 will be more than 60% higher than it was in 2002. Approximately 85% of the future power supply will still be based on fossil fuels, the burning of which represents the most important driving force for climate change. Also, urban agglomerations, and in particular, megacities in developing and newly industrialized countries are important arenas for energy use and production. While cities take up only 2% of the earth's land surface, they are responsible for three quarters of global energy consumption as well as approximately 85% of the global production of greenhouse gases. The underlying trend to urbanization (with an approximate 1.8% increase per year in the global urban population) and to the spreading of megacities is continuous. (NKGCF 2008)

Megacities offer strategic starting points for energy efficiency and climate protection. On the one hand, the concentration of people, material flows and residential districts in megacities makes it possible to reduce the consumption of resources because modern governance, planning and service concepts mean that more people can be supplied more economically using the same amount of transport, energy and space. Such gains in efficiency can flow into the surrounding suburban and rural areas, as well as into the national economy, to which large cities are integrated by means of resource flows and supply corridors. Also, the functional integration of urban industries, infrastructures and networks make the accelerated dissemination of innovations possible, not at least in the energy sector. An integrated approach to urban development is required which takes into account the overlapping fields of responsibility such as buildings, transportation networks, energy technologies, and citizen lifestyles, and integrates these into a long range planning approach. (NKGCF 2008)

Accra, Ghana is a good example of the aforementioned, following in the footsteps of its Nigerian megacity neighbor, Lagos, and transitioning towards income inequality. While its continued expansion will further fuel energy consumption demands, innovation in technology and urban planning could set up sustainable structures and guidelines for energy demand and production which would decouple economic growth from energy consumption and lead emissions from an exponential increase to at least a flattening growth curve.

### 4.1.1 Electricity and the Development Context

Perhaps the most important factor in the modernization of Ghana from a third world country to an industrialized nation is the presence of modern electricity systems in its urban centers. Of all the western world's appurtenances, none has a more profound potential to improve quality of life standards than of a modern electricity infrastructure. The presence of electricity facilities supports all public infrastructures, from transportation systems to potable water and sanitary sewer services, from medical and public education to police, fire, and telecommunications. A reliable electricity supply is critical to the realization of a modern Ghana. (National Development Planning Commission of Ghana, 2005; United Nations, 2006)

Currently there are many plans to improve electricity supply throughout West Africa. The Economic Community of West Africa States (ECOWAS) has commissioned activity that will promote the West African Gas Pipeline Project (WAGP), a primarily submarine natural gas pipe that runs about 30 kilometers off the coast from Nigeria through the Gulf of Guinea west alongside Ghana with spurs to Tema and Takoradi. ECOWAS has also promoted plans for improved transmission through its West Africa Regional Transmission Stability Study, which includes upgrading transmission lines from Volta to Aboadze and then on to Prestea from 161kV to 330kV. Both of these studies include Ghana as part of the larger ECOWAS plan for



the West African Power Pool (WAPP) which envisions a deregulated electricity market that includes all West African states and would operate in a manner similar to power markets in South Africa, Europe, or the Americas. (Nexant Inc., 2004b; The World Bank & MIGA, 2004)

There are also national commissioned plans seeking to improve electricity services across Ghana such as the Bui Dam hydro project on the Black Volta River or proposals to increase generation capacity at the Takoradi Thermal Plant. The national government has also taken steps towards consolidating and restructuring the Electricity Company of Ghana (ECG) and the Northern Electricity Department (NED) of the Volta River Authority (VRA) to promote efficient management. The Public Regulatory Commission (PURC) is considering appropriate tariffs for hydro, thermal, and renewable power generators within a system that is moving towards deregulation, and the Energy Commission of Ghana is working towards a supervisory structure to govern spot and day-ahead market operations and regulation of carbon-dioxide emissions. There have also been commissioned studies seeking to project: electricity affordability for Ghana's largest economic sector, residential households; reduction of wood-fuel consumption when electricity services are made available; and improved indoor air quality as well as women and children's respiratory health. (Energy Commission of Ghana, 2006; Nexant Inc., 2004b)

Currently most Ghanaians rely on wood-fuels as their primary source of energy. Of the nearly 6.6 million Tons of Oil Equivalent (TOE) produced in terms of indigenous energy, approximately 3.8 TOE was derived from wood-fuels. Of this 3.8 TOE derived from wood-fuel, about 75% is by the residential sector in the form of firewood or charcoal and predominantly used for cooking. Household consumption of wood-fuels is also one of the primary contributors to Ghana's rapid deforestation, a loss of more than 6000 sq.km of forests since the year 2000 and 20,000 sq.km since 1990. Comparatively, only 0.5 TOE of indigenous primary energy was produced in the form of electricity from hydro and thermal sources in 2004. Of the approximately 6000 GWhs generated in 2004, more than 50% of all distribution was to residential households and more than 5000 GWhs were consumed by customers of ECG and NED. It should also be noted that the industrial and services sectors, which together account for nearly 75% of Ghana's GDP, rely critically on electricity. (Energy Commission of Ghana, 2006; Royal Danish Ministry of Foreign Affairs & Energy Commission of Ghana, 2003; The World Bank & MIGA, 2004; United Nations, 2006)

## 4.2 Electricity Supply in Ghana

The key players in Ghana's power sector are the Volta River Authority (VRA) responsible for power generation, transmission and system operation for the entire country; the Electricity Company of Ghana (ECG) responsible for distribution in southern Ghana, where most of the electricity is consumed; and the Northern Electricity Department (NED), which is a VRA subsidiary responsible for power distribution in northern Ghana. All of these agencies are owned by the Government of Ghana and regulated by the Energy Commission and the Public Utility Regulatory Commission (PURC). VALCO, which had traditionally been the largest privately owned bulk consumer of electricity, closed its Tema aluminum smelters in 2002. (Nexant Inc., 2004b; The World Bank & MIGA, 2004)

Until recently, the sole sources of power supply in Ghana were from the VRA owned hydroelectric plants of Akosombo (1038 MW, commissioned in 1965) and Kpong (160MW, commissioned in 1982), and imports from Cote d'Ivoire. Since demand was outstripping the supply from the two hydro generation stations and poor hydrologic conditions were increasingly resulting in severe power shortages (such as in 1997 and 1998), the Government commissioned a 330-MW Combined Cycle thermal plant at Takoradi in 1999. The Government followed this by further diversifying its electricity production capabilities with a second thermal plant at the same site in 2000. This second plant, which was developed through a joint-venture partnership between the VRA and CMS Energy (Jackson, Michigan, USA) is a 220-MW Simple Cy-

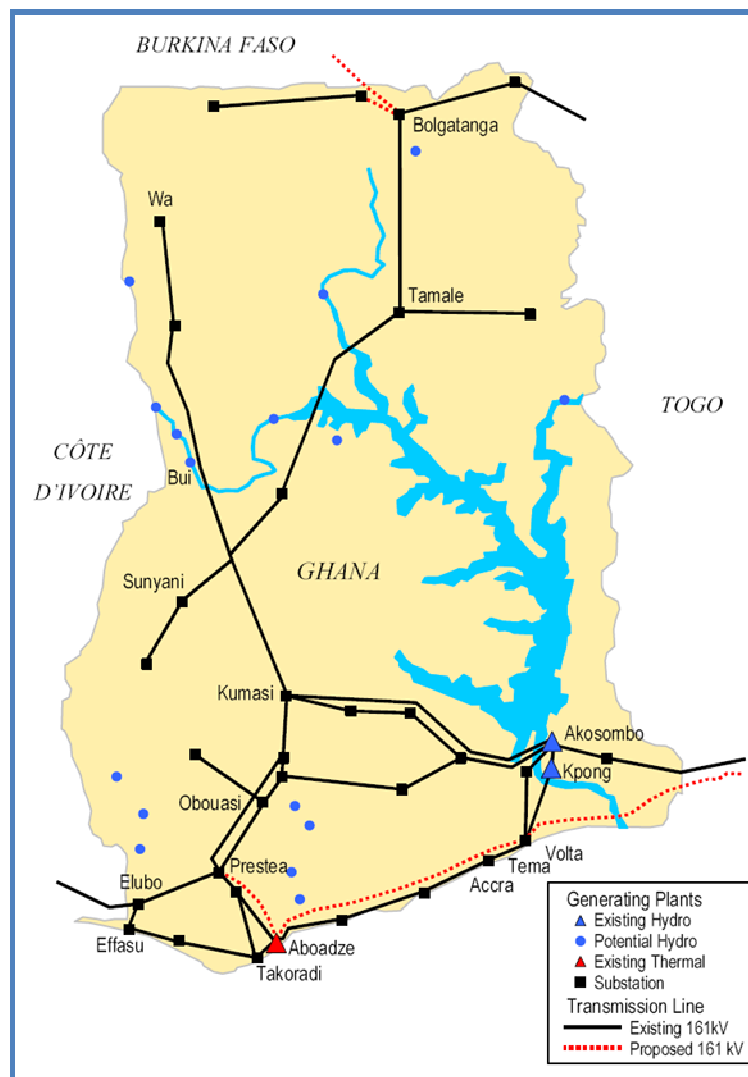

Figure 4.1 VRA Transmission Network

cle thermal plant, with the option for an additional 110-MW steam turbine, once natural gas becomes available. Currently both plants are run on light crude oil imported from Nigeria. (Energy Commission of Ghana, 2006; Nexant Inc., 2004b)

At present, the total generation capacity of the VRA is 1038-MW and 160-MW from the two hydro stations and 550-MW from the two thermal stations. The firm energy supply is made up of 4800 GWh hydro and 2500 GWh thermal, however depending on water inflows into Lake Volta, the hydro output can reach up to 6100 GWh per year. The VRA transmission network is comprised of 36 substations and approximately 4000 km of transmission lines in a loop that covers most of the country. Standard transmission voltages are 161kv and 69kv. Major transmission lines run from the hydro stations at Akosombo and Kpong to Accra and also Kumasi. Additional 161kv lines run from the thermal stations at Takoradi to Accra and also to Kumasi. Ghana's transmission system also has major interconnections with the national electricity grids of Cote d'Ivoire and Togo extending from Prestea and Akosombo respectively. A single circuit 161kv line extends from Kumasi supplying power to northern Ghana, including a minor connection to Burkina Faso. An additional upgrade to the Burkina Faso connection has been planned as an ECOWAS-WAPP priority project. (Energy Commission of Ghana, 2006; Nexant Inc., 2004b; The World Bank & MIGA, 2004)

VRA operates a fully automated modern control center at the Tema substation. A generation pre-schedule, which covers all the generating plants of the VRA as well as in Cote d'Ivoire and Togo, is prepared daily and shared to ensure coordinated operations. All generating units and substations can be monitored from the control center. VRA also has contracts for buying and selling energy with Cote d'Ivoire and Togo, as well as the joint venture with CMS Energy at Takoradi. Tariffs for bulk consumers, including ECG, are also regulated by the Energy Commission and PURC. Action has been taken towards restructuring and cleaning up the VRA and ECG balance sheets, including debt restructuring to settle all accounts among Government entities and reduce some of the debt burden of these companies. This restructuring will enable ECG to start matching electricity demand with the necessary network upgrades and expansions. In the past, ECG has been burdened by under-investment in their power distribution system, overloaded transformers and distribution networks, and the continued use of obsolete equipment, all of which resulted in high distribution system losses and poor electricity supply, quality, and reliability. (Energy Commission of Ghana, 2006; Nexant Inc., 2004b; The World Bank & MIGA, 2004)

In parallel, Ghana is in the process of deregulating its electricity sector, which will include the introduction of an Independent System Operator for transmission management as well as private companies for improved distribution and new thermal generation facilities. This includes plans for CMS Energy to increase electricity production at the Takoradi power complex to 660-MW and operate the plant under a performance based contract. There are also plans to introduce a third, privately owned 330-MW Combined Cycle generation facility once the WAGP spur is completed to Tema. The Ghanaian Government is moving towards tighter coordination in a competitive market environment, which is expected to progress in all areas of development including institutional, legal, and regulatory arrangements. By 2020, Ghana is expecting to conduct electricity trading through day-ahead and hour-ahead markets. (Energy Commission of Ghana, 2006; Nexant Inc., 2004b; The World Bank & MIGA, 2004)

#### 4.2.2 Electricity Sector Issues

For the past 10 years, Ghana has been struggling to meet an increasing electricity demand. From 1988 to 2002, Ghana's electricity consumption increased at an average rate of over 8% per annum, with peak

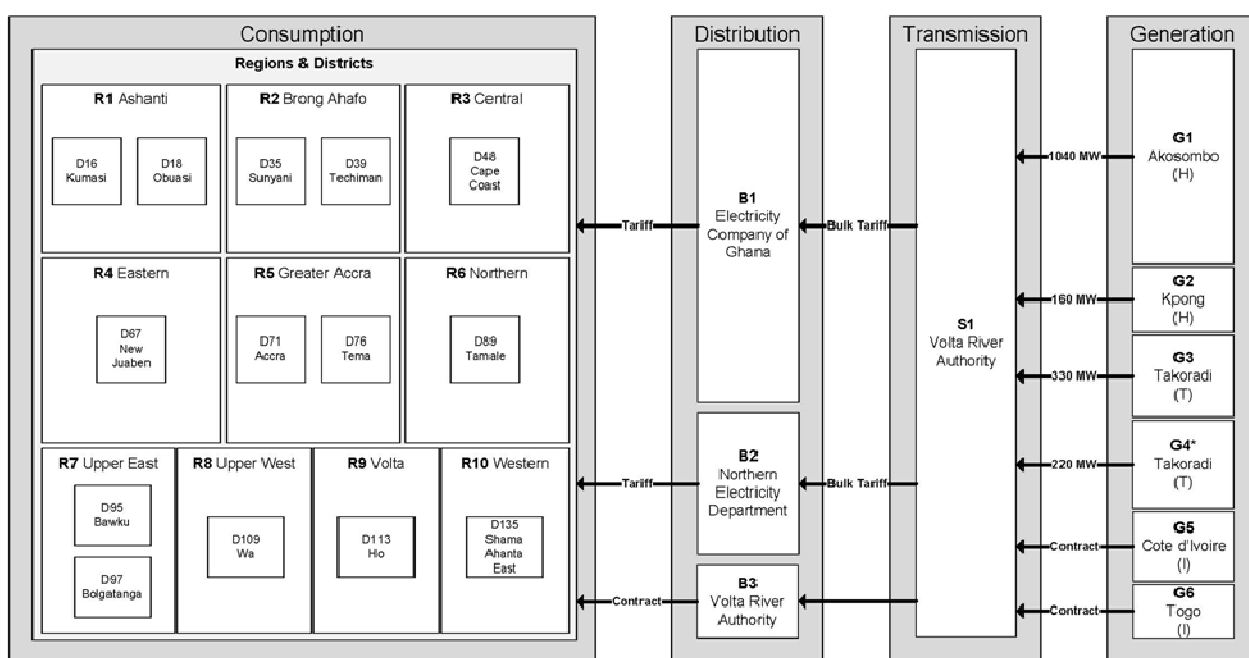

\* With the exception of G4 Takoradi Thermal 220 MW, all Electricity Generation, Transmission, and Distribution Authorities, Companies, Departments and Systems are owned by the Republic of Ghana. G4 Takoradi Thermal 220 MW is a joint venture between CMS Energy USA and the VRA.

Figure 4.2 Electricity System Status Quo in Ghana: Illustrative representation of the current state structure

power supplied by the VRA network reaching 1200 MW and total energy consumed for 2002 at 7400 GWhs. Meeting these demands has been neither cheap nor easy, with costs to generate electricity averaging 8c/kw from imported light crude oil for the Takoradi plants coupled with the severe drought conditions of the recent years which have resulted in structural deficits and the resultant load shedding. Making matters worse, both the VRA and ECG have been characterized by lack of financial discipline, below potential performance, low resource mobilization, and under-investment. This poor fiscal management is evidenced by the 144.9 million USD debt relief granted to the VRA and 95.06 million USD to ECG. (The World Bank & MIGA, 2004)

Infrastructure improvement is badly needed in order to better serve all areas of the country. Major transmission line upgrades are underway, which will increase line voltages from 161kv to 330kv. These include a third line from Volta to Aboadze (Takoradi) to transmit power east-west across the VRA network. This line will eventually tie into an upgraded 330kv line extending from Volta to Mome Hagou, Togo, east to Sakete, Benin, and on to Ikeja West, Nigeria. Along the western coast of Ghana a third line will also be installed to upgrade transmission between Aboadze and Prestea (with the Cote d'Ivoire interconnection) and on to Kumasi. Plans are also in the early stages for connecting Bolgatanga to Ouagadougou, and thus making a circuit with the Cote d'Ivoire network through Burkina Faso. (Nexant Inc., 2004b)

In 2001-2002 Purdue University undertook a Planning Study that comprehensively modeled data and information on West Africa electricity trade and capacity expansion options for the entire region. The West Africa Power Pool Electricity Data Set #6, is a ready source of technical data for modeling generation, transmission and international transactions. In 2004 Nexant incorporated the Purdue model as a primary source of information for its review of the electricity demand/supply balances in its Regional Power System Master Plan. Nexant's analysis of generation and transmission requirements was conducted using

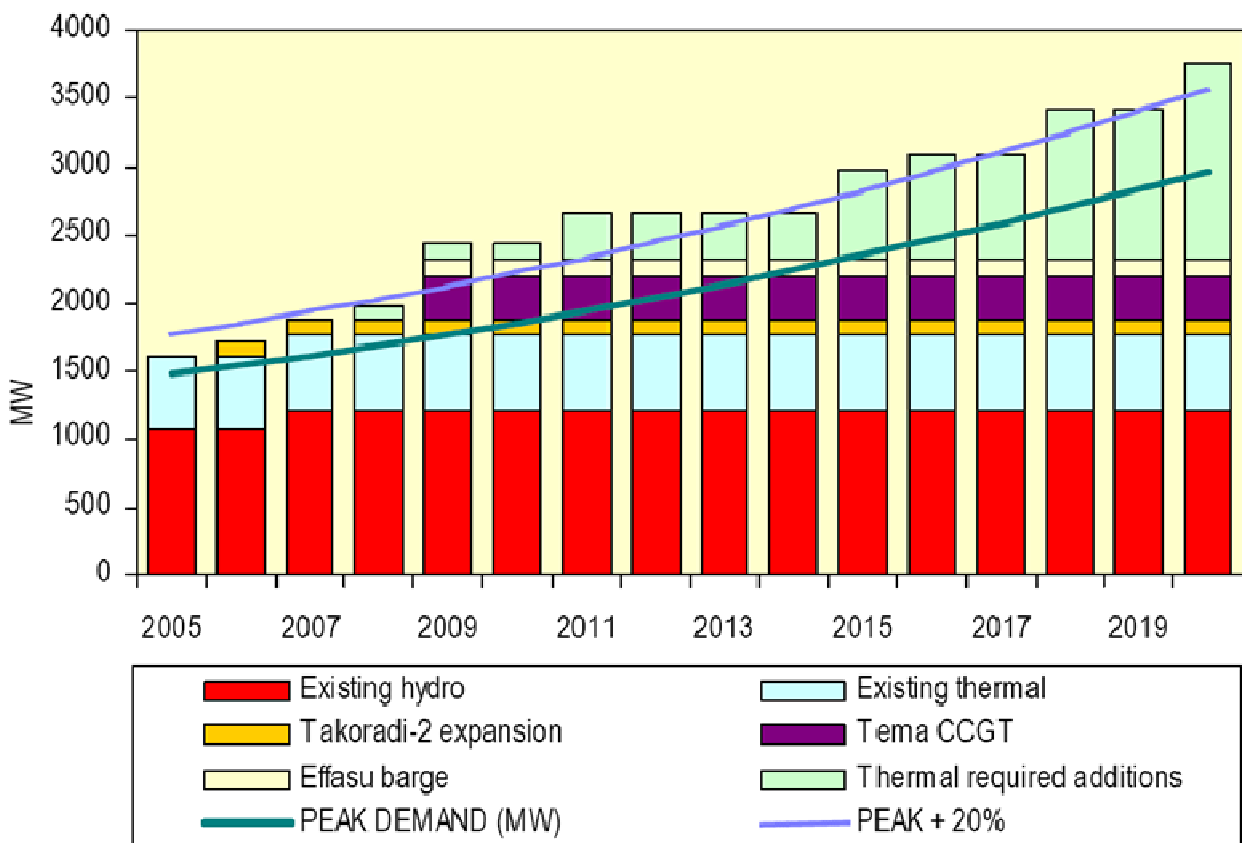

Figure 4.3 VRA Supply / Demand Balance Forecast

the Elfin production simulation model, which was used to prepare an optimum (Least Cost) generation expansion plan. (Nexant Inc., 2004a)

The Nexant Elfin model projects peak and energy demand forecasts for the period 2003 to 2020. In summary, total domestic consumption is expected to grow at an annual average of 6.3 percent from 2000 to 2020. The economy is also expected to grow at a rate of five percent until 2020, based on the growth rate of the past decade. It is also expected that Ghana will move toward a sustainable electricity pricing policy representing long-run marginal cost to ensure that the VRA meets its financial obligations, including commitments to purchase natural gas. A key uncertainty in the demand forecast is the supply to VALCO, which was closed in 2002 with no signs of restarting the plant in the near term. Demand forecasts in Figure 2 assume VALCO will not reopen in the near future. (Nexant Inc., 2004c, 2004d)

### 4.3 Electricity Demand in Accra

The Electricity Company of Ghana has subdivided Accra into 2 Regions, Accra West and Accra East, which is then further subdivided into 12 districts: Makola, Legon, Roman Ridge, Teshie, Korle Bu, Achimota, Bortianor, Dansoman, and three other districts that were unnamed at the time of the data collection. Tema is a separate region unto itself. For the purposes of the electricity demand model which will be presented in a later chapter, the following discussion of electricity demand will focus on the Korle Bu district, which is located in the Accra West Region.

#### 4.3.1 Korle Bu District Described in Terms of Location, Area and Population

According to the 2000 census, the Korle Bu district had a population of 186,593 persons. The district is bordered by Kwame Nkrumah Boulevard along the eastern boundary, Kwame Nkrumah Circle at the

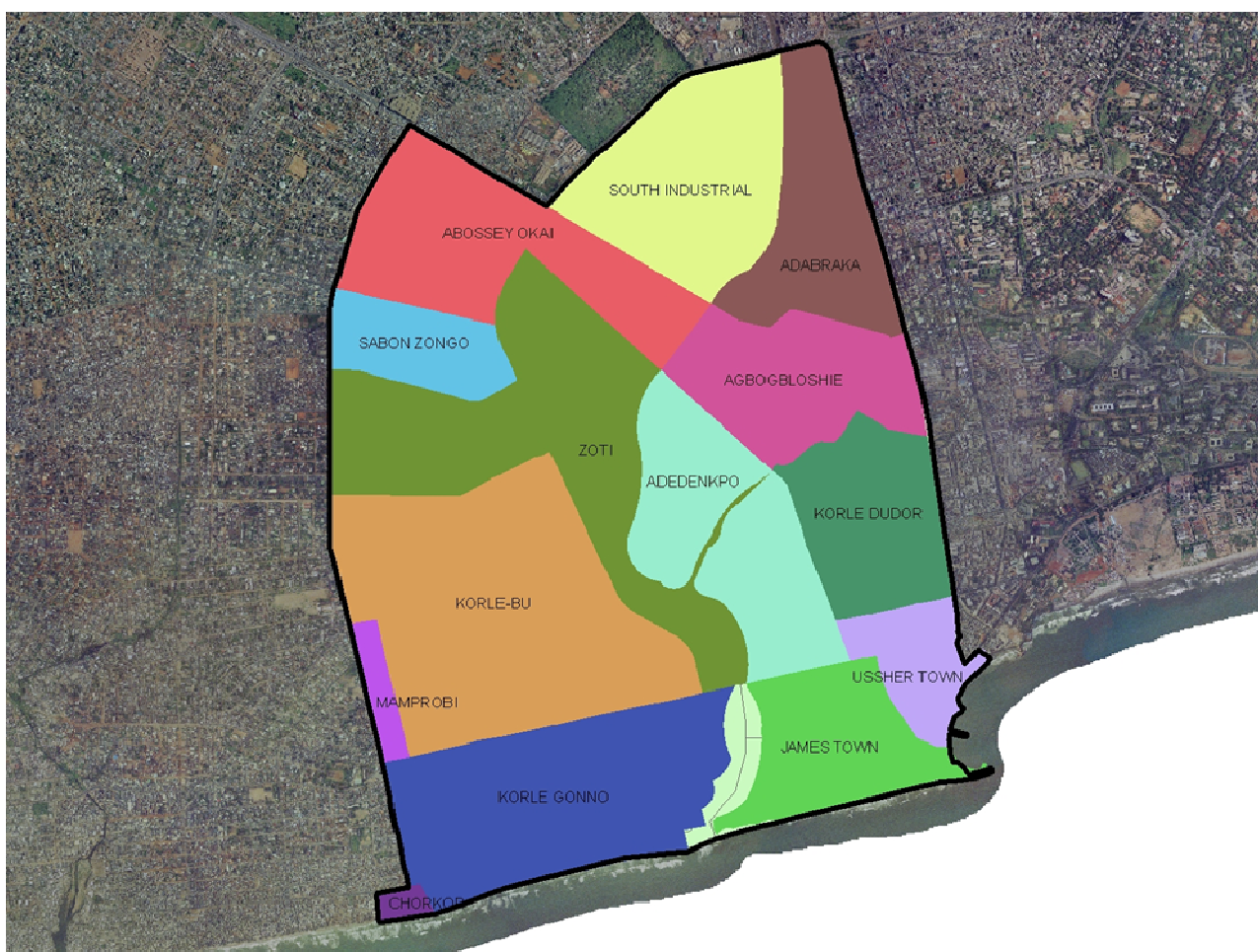

Figure 4.4 Korle Bu District and the Communities Comprising this part of Accra



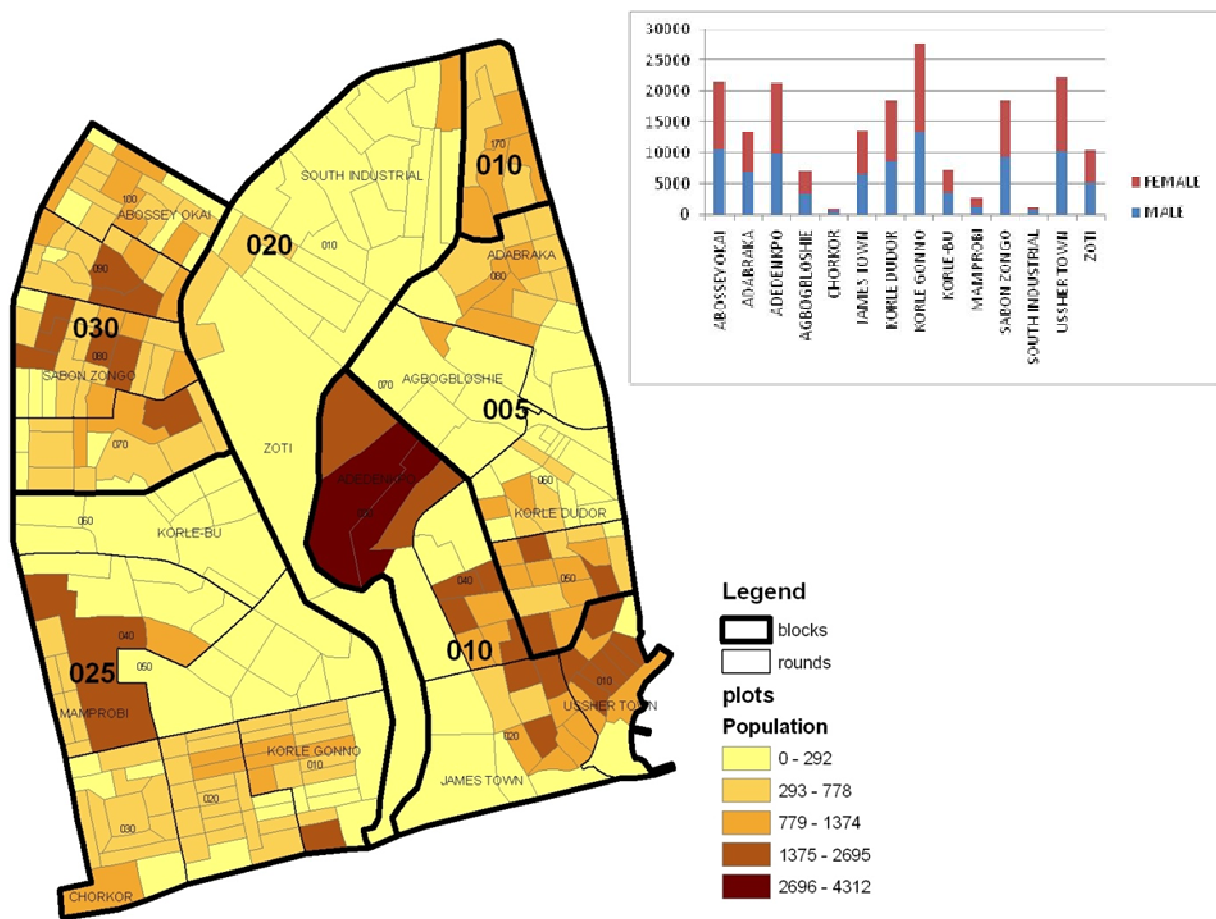

Figure 4.5 Block and Round Boundaries as well as Population by Plot and Community

northwest corner, Ring Road and then Obetsebi Lamptey Circle to the north, Eduardo Mohdlana Road along the western side, and the Gulf of Guinea to the south. The nearly 190,000 persons living in Korle Bu comprise 43,763 households of which 89,857 are men and 96,736 are women. Of these approximately 44,000 households, they occupy 10,964 residential structures which total 1,359,837 square meters in total floor area.

The property itself is subdivided from the district boundary which is 12.6 km<sup>2</sup> in area into five blocks, which have then been subsequently subdivided into rounds and ultimately into plots where buildings or structures are located. James Town and Ussher Town are two of the older communities in Accra and are also primarily residential in nature with fishing along the shoreside. Korle Gonno is one of the more heavily populated subdivisions, which is located across the lagoon. Agboghloshie and Adedenkpo are the location of the largest market in Accra, the end of the rail line as well as one of the largest slums in Ghana. The South Industrial area is characterized by a number of large businesses including many foreign ones, while the Adabraka is directly adjacent to Kwame Nkrumah Circle to the south-west and is significantly characterized by the local business activities typical to Circle as well as some residential land uses.

Two of the more densely populated parts of Korle Bu are Ussher Town near the terminus of Kwame Nkrumah Boulevard as it intersects High Street, and Sabon Zongo to the south of Obetsebi-Lamptey Circle. Ussher Town is one of the oldest section of Accra and is the location of Ussher Fort, a British Prison that predates the Republic of Ghana. Sabon Zongo has also received notoriety for being a destination for immigrants. Much different in terms of land use composition, the South Industrial Area is characterized by a number of large businesses operating in Accra and throughout Ghana. These are some of the most

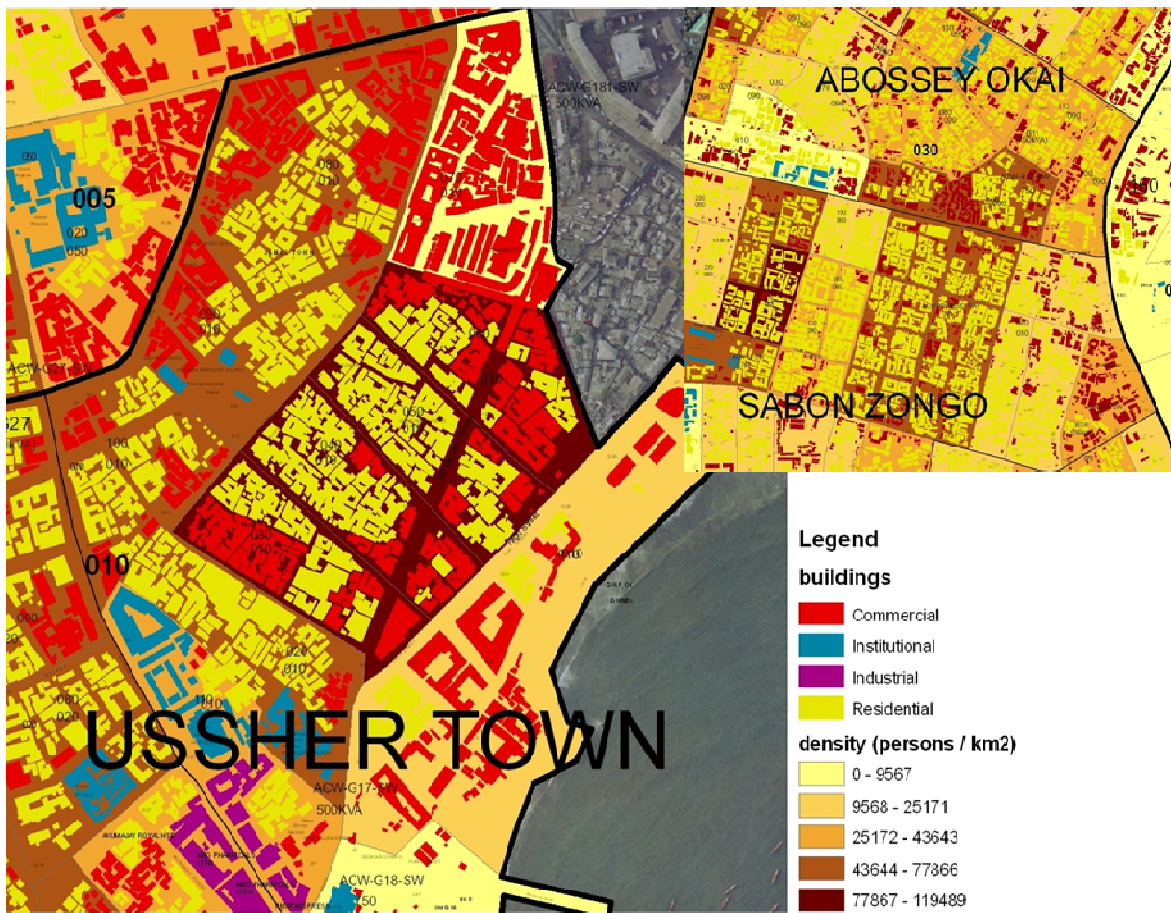

Figure 4.6 Density and Land Use in Ussher Town and Abossey Okai



Figure 4.7 Land Use in the South Industrial Park

valuable properties in Ghana as well as the highest consumers of electricity. African Concrete Products, Super Industries, Ghana Rubber Products, as well as a number of automobile dealerships and construction businesses are located in the South Industrial Park.

### 4.3.2 Consumption by Plot and Land Use

The following figure illustrates the total electricity consumption in Kilowatt-Hours for the time period from October 2006 until January 2008. The highest power consumption is in the area of the South Industrial Area, while the commercial center on the west side of Kwame Nkrumah Boulevard (Swanzy Shopping Arcade and multiple office buildings adjacent to the south) also consumed significant amounts of electricity during this time period. The mixed commercial and residential land uses to the west of Obetsebi-Lamptey Circle in Abossey Okai, also consumed significant amounts of power.

Electricity consumption in the South Industrial Area typically ranges from 5,000 to 35,000 kWh per month, but two of the plots consumed considerably more electricity. Plot 0030 in the South Industrial Area, which is the site of Super Industries Ghana, African Concrete Products, Vicon Processing, Prestige Steel, Carbon Products, Meriplastic Manufacturing, Crown Rice Mills and many other industrial land uses, demonstrated a remarkable increase in electricity consumption. Land uses located within this plot exhibited an increase in consumption of more than 12 fold on average and a more than 200 times increase from the lower amounts of demand late in 2006 and early in 2007 to the highest mark in more than 5,000,000 kWh in August 2007, at the height of the global economic boom.

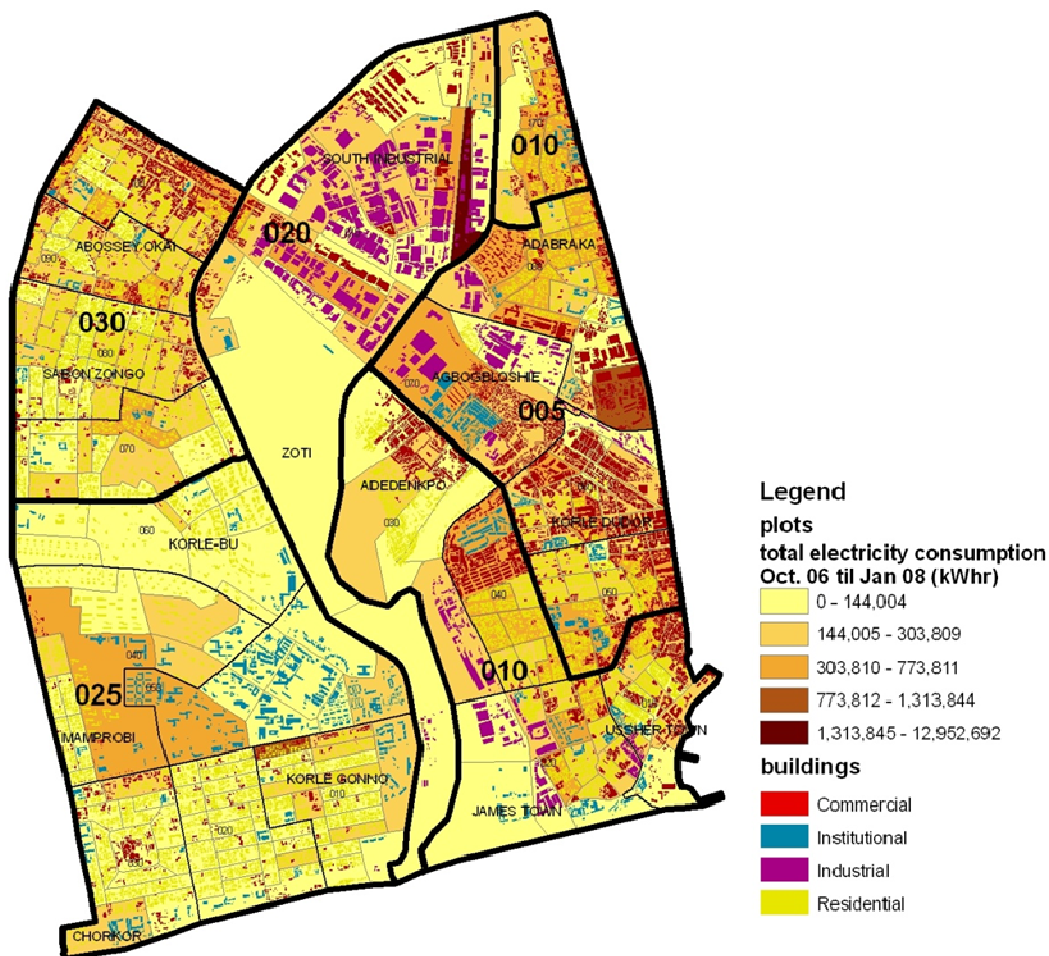

Figure 4.7 Korle Bu Electricity Consumption by Plot and Land Use



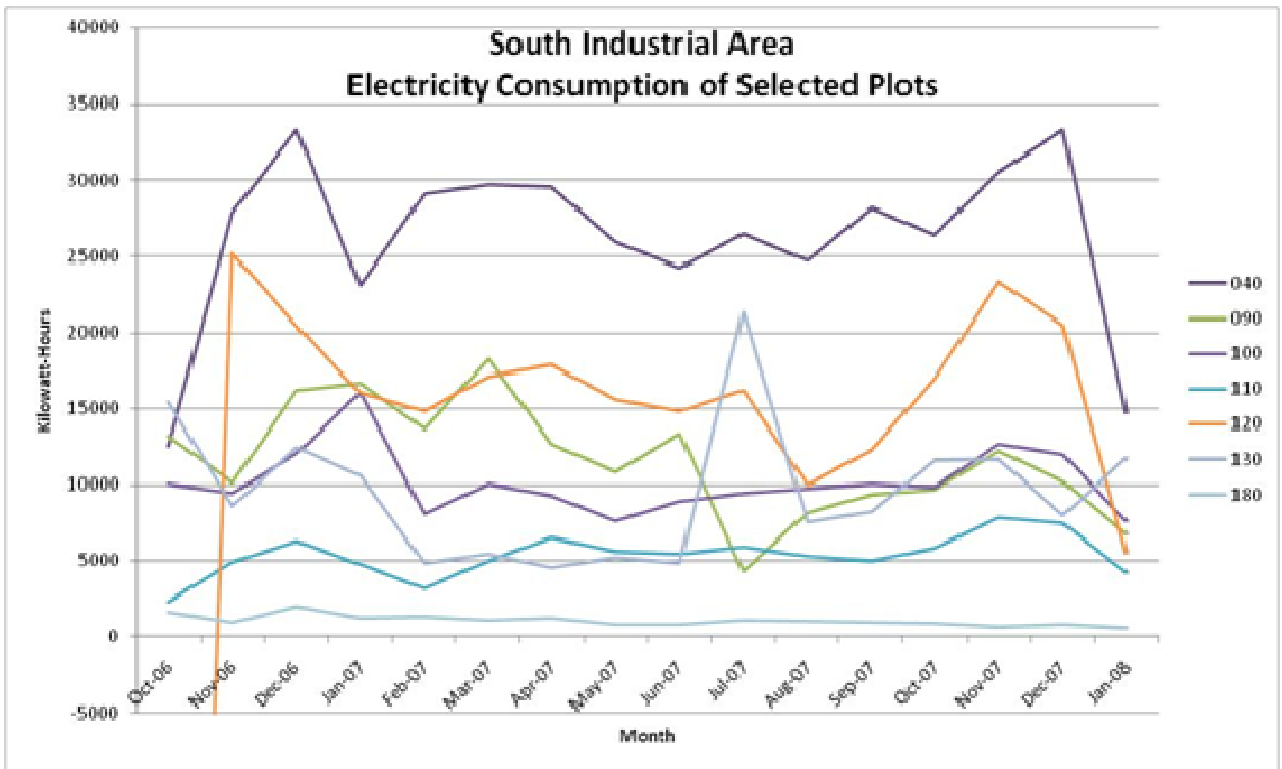
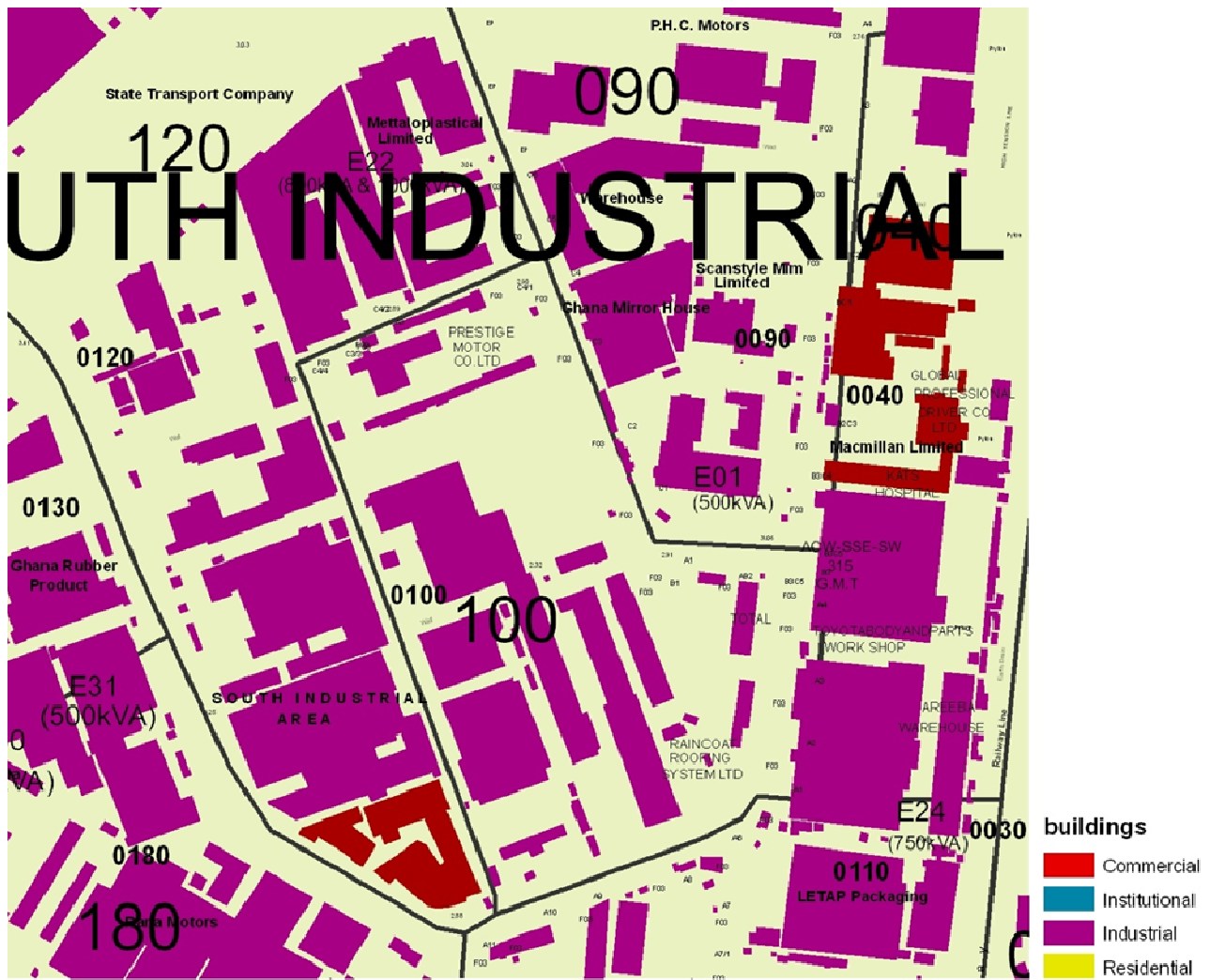

Figure 4.8. Electricity Consumption Profiles of Plots in the South Industrial Park from October 2006 until January 2008

Plots 0190 and 0200 in the South Industrial Park are also remarkable since they have demonstrated increases in electricity consumption, and strong peaks in certain months. While the consumption averages are not as significant as Plot 0030, they demands are still more than the typical consumption profile. A number of automobile dealerships are located in this area, including Nissan, Japan Motors, Kia Motors, Honda Motors as well as Silver Star, Rainbow Trading Company, Bonsu and Brothers, Presbyterian Press, Pepsi, Accra Machine Shop and Princes Cold Stock, among others. The more typical electricity consumption profile is exhibited by Plots 0090, 0100 and 0120 as illustrated in the previous figure.

Some of the more intense commercial land uses are located along both sides of Kwame Nkrumah Avenue heading south from Circle towards High Street and the Gulf of Guinea. For the purposes of this inquiry, the focus will be upon the west side of Kwame Nkrumah Avenue, since it is the eastern boundary of the Korle Bu district. Agboghloshie and Korle Dudor are the larger communities where many commercial developments and aggregations of local commercial activities as well as informal businesses are located. The Swanzy Shopping Center, the Cocoa Board, and adjacent businesses are located in this area, as well as Ghana's main railroad, which terminates amidst the businesses located along Graphic Road and in immediate proximity to Katamanto Market. A number of large banks are located in this vicinity, and even more so in the approach to High Street.

Typical consumption for commercial land uses are similar to those for the industrial land uses found in the South Industrial Park. While individual uses which have higher peaks are not as extreme compared with industrial activities, on the whole, commercial land uses trend towards slighter higher consumption rates, averaging from 10,000 kWh per month upwards to 50,000 kWh. The plot where the Swanzy Shopping Arcade is located exhibited the highest consumption rates, as well as noticeable increases in demand during this time period. Averages consumption rates for the local shopping center approximated 60,000 or 70,000 kWh per month late in 2006 while increasing more towards 90,000 early in 2008. Similar increases should be expected for other commercial shopping centers such as the Accra Mall at Tetteh Quarshie Interchange.

Residential electricity consumption rates typically range from 5,000 to 15,000 kWh per month as illustrated by consumption in the predominantly residential subdivision of Korle Gonno, which is directly to the south of the large institutional complex, the Korle Bu Teaching Hospital. A number of churches and schools are interspersed throughout the area, as well as commercial establishments of various sizes. Plot 130 which borders Guggisberg Avenue had a significant peak of electricity consumption (nearly 1,000,000 kWh in a single month) which approaches the outlying peaks demands from the industrial and commercial land uses. This is unusual, especially since the only significant commercial use is the Mobile Filling station and a number of other smaller commercial activities. The majority of buildings in this plot are residential as well.

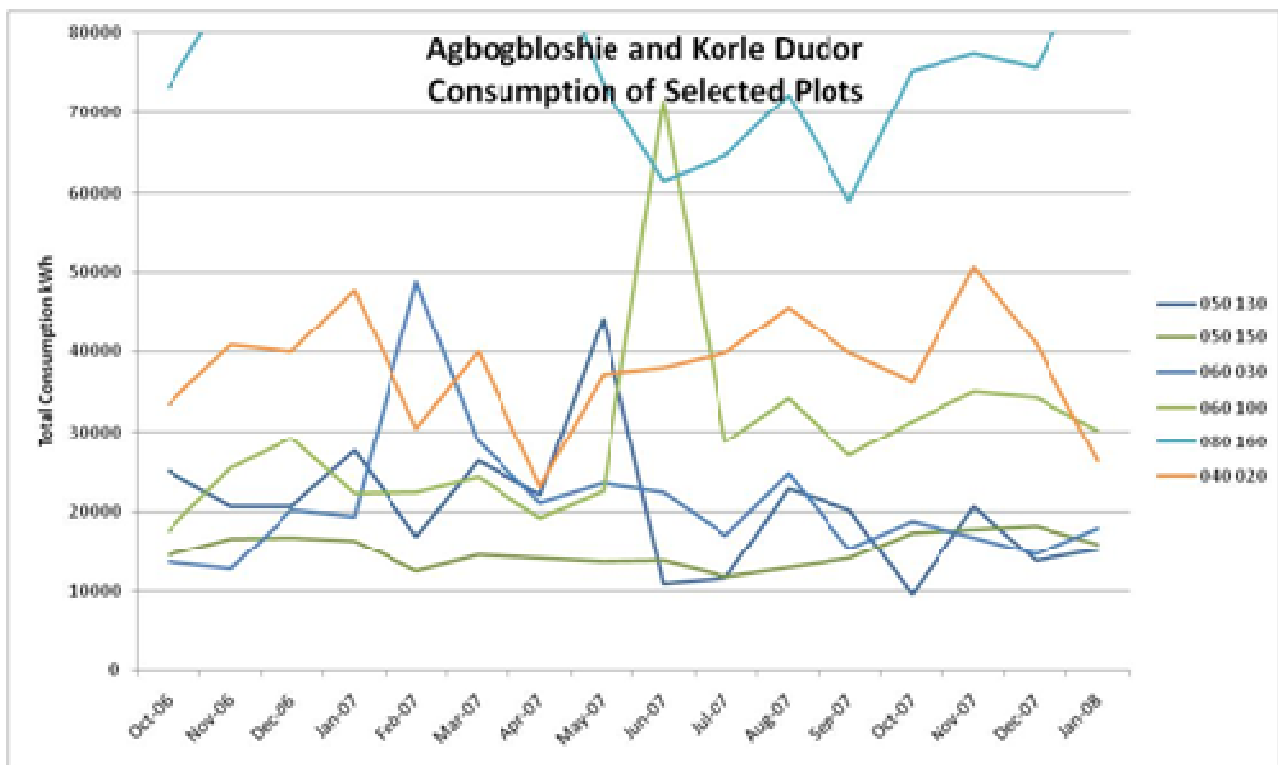
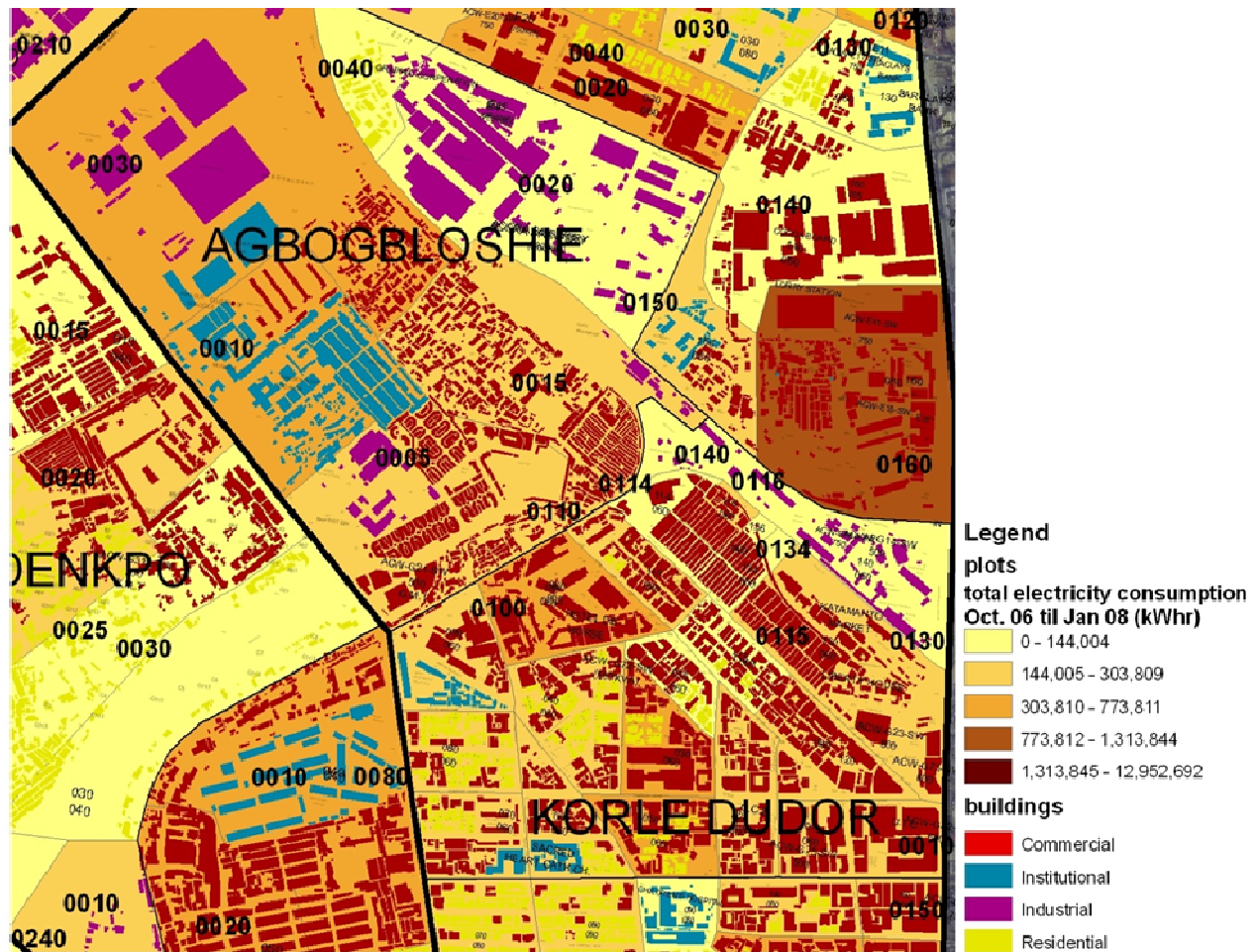

Figure 4.9 Consumption Profiles of Commercial Land Uses per Plot in Agbogbloshe and Korle Dudor

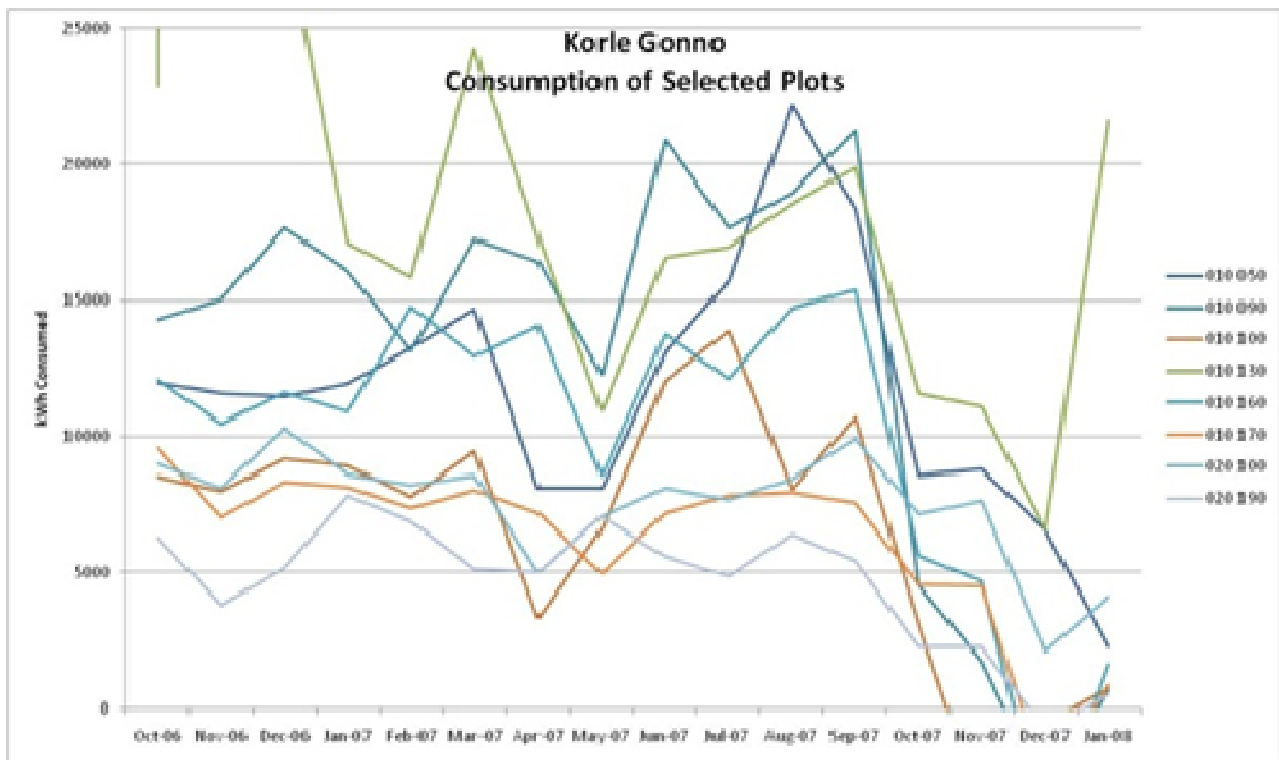
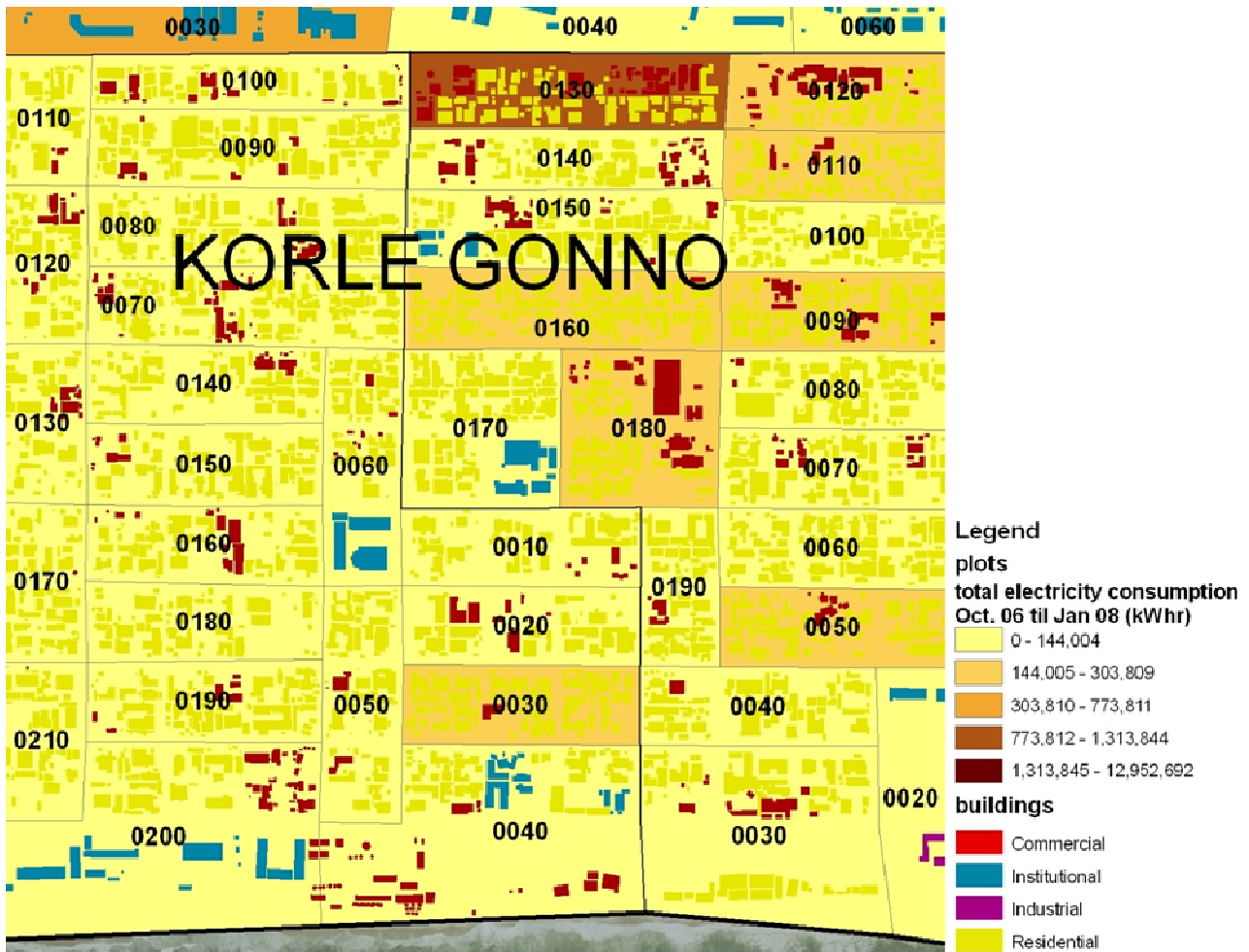

Figure 4.10 Consumption Profiles of Residential Plots in Korle Gonno

# **Chapter 5**

**Greater Accra**

**Urban Simulation**

**Korle Bu District**



## 5.1 Urban Simulation System Described

The Greater Accra Urban Simulation for Korle Bu (GAUS-KB) is comprised of different models which project the population and composition of households, employment, land development and infrastructure from the year 2006 until 2025. Household & employment models predict how the total Korle Bu population transitions from year to year, determines if an existing family or job will decide to relocate and then determines the best match for these moving families and jobs within a building at a new location. Land development models set the price of land, predict if and what type of new development projects will likely be proposed in Korle Bu, and then add new dwellings or floor area to existing parcels in order to accommodate demand for housing and jobs. An infrastructure model introduces a highly disaggregated electricity demand model for Korle Bu in terms of land use, household and employment attributes for each zone (plot).

GAUS-KB is fundamentally comprised of three different parts: data, which was obtained in Accra and describes the subject study area; models, which use the data as input for running discrete choice, regression, or allocation models; and scenarios, which use exogenous data for input into the model system. GAUS-KB inputs data from either the baseyear or scenario database. The baseyear database contains all the information on households, jobs, buildings, parcels, transportation and electricity which defines the initial state when the simulation starts, which is at the end of the year 2005. The scenario database contains data for simulating low, medium or high population and economic growth rates.

### 5.1.1 Data Sources

The largest and most significant datasets used in this research to describe Korle Bu and Greater Accra, were obtained from: the Ghana Statistical Service (GSS); the Electricity Company of Ghana (ECG); and the Lands Commission. GSS Administration has provided the entire dataset from the fifth round of the Ghana Living Standards Survey (GLSS5) which covered a nationally representative sample (8,687 households and 37,128 persons), but for this research the 1,107 households containing 3,447 persons who reside within

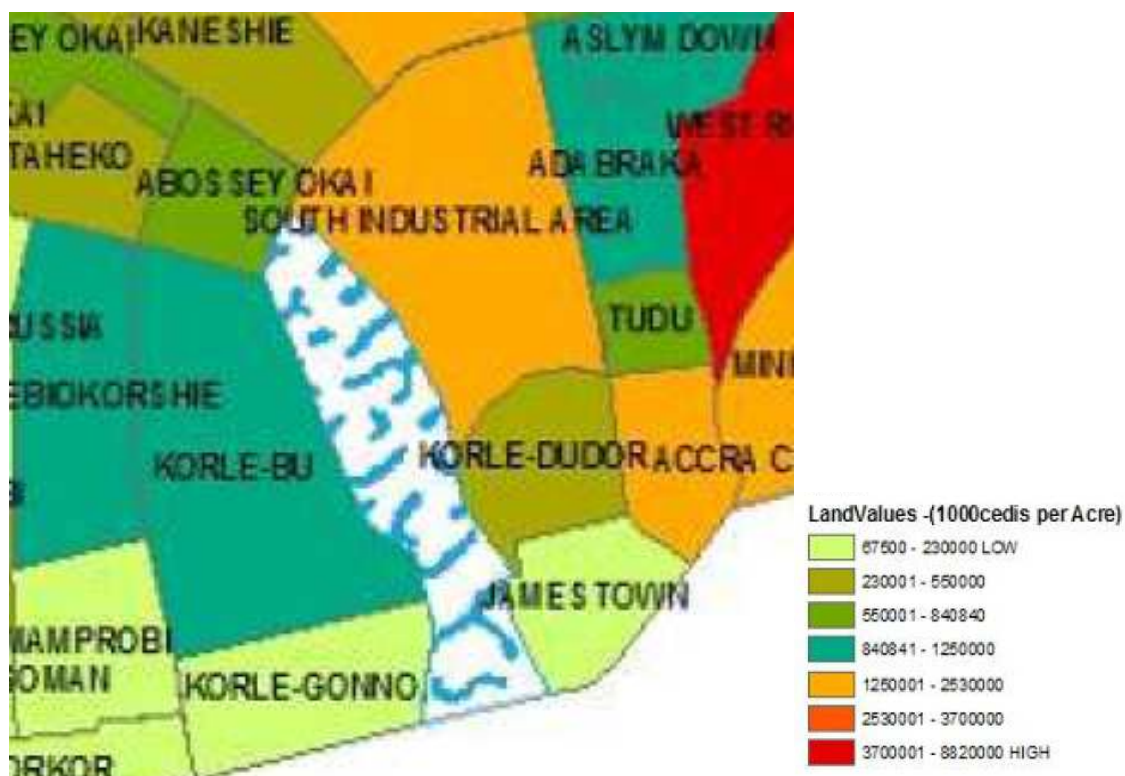

Figure 5.1 Industrial and Commercial Property Values in Korle Bu from the Africa Region Working Paper Series Number 110: Development of the Cities of Ghana (World Bank)

$$R_{\text{owners}} = 3.04 + .053x_{\text{income}} - 0.07x_{\text{hhsz}} + 0.00x_{\text{hhsz}^2}$$

$$R_{\text{renters}} = 1.04 + .072x_{\text{income}} + 0.24x_{\text{hhsz}} - 0.01x_{\text{hhsz}^2}$$

Where:

R = housing rents

$\beta_0$  = constant

$x_{\text{income}}$  = log of income per capita

$x_{\text{hhsz}}$  = household size

$x_{\text{hhsz}^2}$  = household size squared

Figure 5.2 Residential property values: Regression formula of Property Values in Accra from Buckley et al.

the Greater Accra Metropolitan Area (GAMA) were used. The GSS Geographic Information System (GIS) Section provided 2000 Population and Household Census Data for Ghana, as well as the Enumeration Area Map, which spatially describes the boundaries of all localities in Ghana, and most importantly throughout Greater Accra. ECG Administration has provided a thoroughly robust dataset of the historical record of electricity consumption for every meter (as well as the land use at that meter) in Accra West and Accra East per month for the time period from October 2006 until January 2008. The ECG Survey Department has provided physical data in AutoCAD format describing all property boundaries throughout Greater Accra, to the level of plot, as well as individual meter locations and annotations which describe land use.

The Lands Commission Survey Department has provided physical data in AutoCAD format on all structures throughout Greater Accra, including all buildings, roads, and annotations. The Survey Department also provided orthofotos of the region at 60cm resolution, as well as photographs of Land Title Districts and Sectoral Maps, but ECG data was considered preferred since it was provided in a digital format that was more readily converted for use in a GIS. Land use per plot and structure has been individually determined by the author, by using the land use designation in the ECG dataset, annotations from both the ECG and

$$\mu = \beta_0 + .077x_{\text{sex}} - 0.11x_{\text{age}} - 0.08x_{\text{cohort}} + 0.31x_{\text{edu1}} \text{ or } 0.49x_{\text{edu2}} + 0.07x_{\text{dweltype}} - 0.34x_{\text{occupystat}}$$

Where:

$\mu$  = number of incidents

$\beta_0$  = constant

$x_{\text{sex}}$  = sex

$x_{\text{age}}$  = age

$x_{\text{edu1}}$  = primary or junior secondary school versus non – educated

$x_{\text{edu2}}$  = senior secondary school or University versus non – educated

$x_{\text{dweltype}}$  = compound housing versus flat or self – contained house

$x_{\text{occupystat}}$  = freeholder versus owner or tenant

Age/Income	0-35	36-249	250-599	600-959	960-1301	1302-1919	1920-3159	3160-100000	Mean
15-19	0.133013	0.131223	0.182112	0.126377					0.143181
20-24	0.123688		0.130773	0.133227	0.124518	0.128205	0.153337	0.180859	0.13923
25-29	0.102521	0.111597	0.114808	0.126122	0.124093	0.118106	0.130143	0.123715	0.118888
30-34	0.096336	0.087733	0.104155	0.089789	0.094839	0.099655	0.113142	0.111723	0.099672
35-39	0.081382	0.071712	0.074156	0.077072	0.085478	0.088004	0.097852	0.098497	0.084269
40-49	0.059396	0.070479	0.064743	0.067391	0.066962	0.070236	0.077083	0.080031	0.06954
50-59	0.055671	0.055082	0.053964	0.054074	0.05247	0.056731	0.062332	0.070263	0.057573
60-100	0.047353	0.049653	0.055031	0.050041	0.048988	0.054145	0.045664	0.058313	0.051149
Mean	0.08742	0.082497	0.09746775	0.090511625	0.085335429	0.087868857	0.097079	0.103343	

Figure 5.3 Transformed Cox Regression of Residential Mobility in Greater Accra from Bertrand et al. (Top) and application to GAMA observations from the GLSS5 for use in the Annual Relocation Rates table in GAUS-KB (Bottom)





Figure 5.4 Property Subdivisions in Korle Bu in Rounds and Plots (also referred to as Zones)

Lands Commissions’ Survey Departments, as well as from numerous field surveys throughout the study area from 2007 to 2009.

While the Lands Commission, Land Valuation Board for Greater Accra has a comprehensive set of land valuation data on every plot throughout Greater Accra, after numerous efforts to obtain the data, it was not released. Land value averages have been obtained for each Enumeration Area throughout Greater Accra from the World Bank’s Africa Region Working Paper Series Number 110: Development of the Cities of Ghana, from the estimated land value data provided by the Greater Accra Metropolitan Assembly, as





Figure 5.5 Building Types in Ussher Town

well as a study of real estate values conducted by the Rockefeller Foundation in association with the World Bank. (Figure 5.1) Industrial and commercial land uses range in value from 4 to 63 GHC per m<sup>2</sup> while residential values have been estimated from Buckley et al. (Figure 5.2) Synthetically derived households were used with the household location choice model from the year 2005 to estimate these residential property values.

Coefficients of residential mobility have been estimated from the work of Monique Bertrand and Daniel Delaunay, Residential Mobility in the Greater Accra Region: Individual and Geographical Differentiations. Bertrand et al. provide a general synthetic model of the factors of variation involved in the residential mobility in Greater Accra as well as a mean rate of mobility for a number of different neighborhoods. Bertrand et al. indicate Old Teshie, Lagos Town and New Fadema have mobility rates of 3.1%, 4.5% and 9.3% respectively, while Greater Accra as a whole has a probability of 8.6%. The areas of Lagos Town (New Town) and New Fadema are the closest in terms of proximity to Korle Bu, but are relatively small communities when compared to the study area which is a district of nearly 200,000 persons. In fact Korle Bu incorporates a diversity of distinct communities which all exhibit somewhat different characteristics. The areas of James Town and Ussher Town are comparable to Old Teshie while Agbogbloshie exhibits characteristics typical of very low residential mobility, while other areas may be comparable to New Town or New Fadema. Presented in terms of the odds or hazard ratio in a Cox regression model, these parameters were transformed with the parameters applied to the 1107 GAMA observations. For the purposes of this study, the mean household mobility rate was set at 7.8%. It may seem counterintuitive that an increase in annual income (in GHCs) positively correlates to increased residential mobility. (Figure 5.3)

Coefficients of employment mobility by sector were estimated from GLSS5 data, but these figures are

ID	Sector	Frequency	Percent
1	Single Family Residential	2,695	13.61
2	Multi-Family Residential	8,269	41.76
11	Service-Institutional	1,314	6.64
12	Industrial	886	4.47
13	Office	2,238	11.30
14	Retail	2,120	10.71
15	Highway Retail	2,281	11.52
total		19,803	100.00

Figure 5.6 Building Types: including the number of each type of building in Korle Bu

admittedly quite raw and require further investigation and study in the future. Variables which included observations for employment by sector, amount of time at current job, and time since taking a new job were taken into account for estimating employment mobility.

## 5.2 Datasets

GAUS-KB is comprised of four different types of datasets: those providing information about land, households, employment, and infrastructure. The two primary datasets about land are the zones and buildings tables, which describe property within Korle Bu, as well as the numerous buildings. Datasets about households include demographic information which describes the households and persons living throughout Korle Bu. Datasets about employment are primarily contained in the jobs table, which describes each individual job, throughout the district. Finally, datasets about infrastructure includes travel\_data times to and from each zone as well as historical electricity consumption patterns.

### 5.2.1 Datasets about Land

There are two datasets which describe characteristics related to land, the zones table and the buildings table. The zones table includes variables which describe the size of the property and how much of the property has already been developed. It also contains data regarding the predominant type of development located on the property, whether residential, commercial, industrial, or institutional. (Figure 5.4) The buildings table includes variables which describe the building type, the existing and maximum number of jobs and households, as well as the average value per unit. (Figure 5.5)

The building\_types table is used by GAUS-KB as a reference for each of the different types of structures located throughout Korle Bu. Residential building types are designated as either single family (one household per residential structure) or multi-family (more than one household), while commercial structures are designated as either office, retail or highway retail, with highway retail being considered the smallest structures which are most often located immediately adjacent to roadway, often within the right-of-way. Service or institutional structures are generally hospitals, schools or buildings housing other public services, while industrial are generally quite large in size and located either the North or South Industrial Parks. (Figure 5.6)

coefficient name	estimate	standard error	t statistic	variable name
ln_avg_hh_income	0.397204	0.0344578	11.5273	ln(building.aggregate(household.income,function=mean))
ln_emp_30_min	0.209228	0.0456355	4.58476	ln_bounded(building.disaggregate(urbansim_zone.zone.number_of_jobs_within_30_am_low_time_threshold))
ln_households	0.100648	0.0219955	4.57586	ln(building.number_of_agents(household))
ln_job_density_zone	0.0123342	0.00221957	5.55703	building.disaggregate(zone.number_of_agents(job)/zone.area)/1000
ln_pop_density_zone	-0.0161921	0.0120318	-1.34577	building.disaggregate(zone.aggregate(household.persons)/zone.area)/1000
zone_area_bldg	-0.0397923	0.0183041	-2.17395	building.disaggregate(zone.area)

Figure 5.7 Real Estate Price Model Coefficients (top) and Specifications (bottom)

The `real_estate_price_model_coefficients` and `real_estate_price_model_specification` tables contain the variables and parameters used in the model to estimate real estate value. Dependent variables of average household income, the number of jobs within 30 minutes travel time, the number of households, job density within that particular zone, population density and the total building area are used to estimate real estate price for each building type in accordance with the zone where it is located. The coefficients table provides the parameters for each variable used in the regression, while the specification table defines the variable in python for interpretation by the operating platform. (Figure 5.7)

### 5.2.2 Datasets about Households

The primary dataset which describes households is the households table, which is a synthetically generated population of all households in Korle Bu, including attributes such as number of persons,

```

. sum

```

Variable	Obs	Mean	Std. Dev.	Min	Max
persons	1107	3.31346	2.175449	1	15
workers	1107	1.250226	.8682086	0	7
children	1107	1.543812	1.696349	0	8
income	1107	1881.198	4059.816	0	57840
dwel~type	1107	3.869015	1.470631	1	9
no_rooms	1107	1.828365	1.255508	1	9
occupy~s	1107	2.036134	.8127347	1	4
area	1107	43.82993	195.5936	2.2	4700
rent~annual	1107	124.2895	1446.925	0	47450

```

. corr, wrap
(obs=1107)

```

	persons	workers	children	income	dwel~e	no_rooms	occupy~s	area	rent_a~l
persons	1.0000								
workers	0.5080	1.0000							
children	0.9007	0.3680	1.0000						
income	0.2197	0.3383	0.1275	1.0000					
dwel~type	-0.1988	-0.0968	-0.1182	-0.1861	1.0000				
no_rooms	0.3898	0.1970	0.2905	0.3772	-0.4470	1.0000			
occupy~s	-0.2529	-0.1051	-0.2182	-0.1158	0.2180	-0.3253	1.0000		
area	0.0695	-0.0138	0.0369	0.0210	-0.0586	0.1064	-0.0959	1.0000	
rent~annual	0.0157	0.0458	0.0037	0.0673	-0.0671	0.0442	-0.0032	0.0074	1.0000

```

. sum

```

Variable	Obs	Mean	Std. Dev.	Min	Max
persons	53244	3.329239	2.165254	1	15
workers	53244	1.253418	.8692657	0	7
children	53244	1.555236	1.689618	0	8
income	53244	1883.808	4082.573	0	57840
dwel~type	53244	3.859721	1.472786	1	9
no_rooms	53244	1.837428	1.266009	1	9
occupy~s	53244	2.038164	.8115951	1	4
area	53244	44.60172	205.2088	2.2	4700
rent~annual	53244	125.9327	1458.993	0	47450

```

. corr, wrap
(obs=53244)

```

	persons	workers	children	income	dwel~e	no_rooms	occupy~s	area	rent_a~l
persons	1.0000								
workers	0.5081	1.0000							
children	0.8992	0.3653	1.0000						
income	0.2201	0.3345	0.1283	1.0000					
dwel~type	-0.1994	-0.0921	-0.1183	-0.1845	1.0000				
no_rooms	0.3893	0.1895	0.2893	0.3762	-0.4455	1.0000			
occupy~s	-0.2540	-0.1041	-0.2196	-0.1184	0.2145	-0.3241	1.0000		
area	0.0685	-0.0089	0.0391	0.0194	-0.0551	0.0947	-0.0895	1.0000	
rent~annual	0.0148	0.0457	0.0029	0.0679	-0.0686	0.0452	-0.0034	0.0071	1.0000

Figure 5.8 Households Table including a Comparison of Summary Statistics and Variable Correlations from GAMA Survey Observations (Top) and the Synthetically Generated Households for Korle Bu (Bottom)

HH Size	2006	2007	2008	2009	2010	2011	2012	2013	2014	2015	2016	2017	2018	2019	2020	2021	2022	2023	2024	2025
1	16505	16835	17172	17515	17866	18223	18587	18959	19338	19725	20120	20522	20932	21351	21778	22214	22658	23111	23573	24045
2	8649	8822	8998	9178	9362	9549	9740	9935	10134	10336	10543	10754	10969	11188	11412	11640	11873	12111	12353	12600
3	7537	7688	7841	7998	8158	8321	8488	8658	8831	9007	9188	9371	9559	9750	9945	10144	10347	10554	10765	10980
4	6613	6745	6880	7018	7158	7301	7447	7596	7748	7903	8061	8222	8387	8555	8726	8900	9078	9260	9445	9634
5	6414	6542	6673	6807	6943	7082	7223	7368	7515	7665	7819	7975	8135	8297	8463	8632	8805	8981	9161	9344
6	4164	4247	4332	4419	4507	4597	4689	4783	4879	4976	5076	5177	5281	5387	5494	5604	5716	5831	5947	6066
7	1679	1713	1747	1782	1817	1854	1891	1929	1967	2007	2047	2088	2129	2172	2215	2260	2305	2351	2398	2446
8	796	812	828	845	862	879	896	914	933	951	970	990	1010	1030	1050	1071	1093	1115	1137	1160
9	580	592	603	616	628	640	653	666	680	693	707	721	736	750	765	781	796	812	828	845
10	230	235	239	244	249	254	259	264	269	275	280	286	292	298	303	310	316	322	328	335
11	40	41	42	42	43	44	45	46	47	48	49	50	51	52	53	54	55	56	57	58
12	0	0	0	0	0	0	0	0	0	0	0	0	0	0	0	0	0	0	0	0
13	0	0	0	0	0	0	0	0	0	0	0	0	0	0	0	0	0	0	0	0
14	37	38	38	39	40	41	42	43	43	44	45	46	47	48	49	50	51	52	53	54
totals	53244	54309	55395	56503	57633	58786	59961	61161	62384	63632	64904	66202	67526	68877	70254	71659	73093	74554	76046	77566

Figure 5.9 Household Control Totals Table for 2% Increase in Population

children, workers, and total household income. The total number of households for the Korle Bu Region was determined from the 2000 census totals with a 4% increase per year through 2005. Using the survey weights and the bootstrap method in Stata, a resample population of 53,244 households was created with statistical parameters which are nearly identical to the original sample population. (Appendix B) Figure 5.8 presents summary statistics of the original survey observations and the synthetically generated population including correlation amongst all variables.

The annual\_household\_control\_totals table contains the number of households scheduled for potentially moving into the district for each of the simulation years. The table is structured according to household size, ranging from single person households up to 12 persons within a household. The rate of increase for each year determines the population growth rate, with low scenarios set at a 2% rate of increase and high growth rates at 4%. (Figure 5.9) The annual\_household\_relocation\_rates table contains the probability that a particular type of household will move at least once within a given simulation year. Household types are defined in accordance with the age of the head of household as well as the total family income. These probabilities are a simplified form derived from the modified Cox regression of Bertrand et al. (Figure 5.3)

The household\_location\_choice\_model\_coefficients and household\_location\_choice\_model\_specification tables contain the variables and parameters used in the model to determine the new location for a household which has been scheduled to move. Similar to the real estate model, dependent variables of average household income, the number of jobs within 30 minutes travel time, the number of households, job density within that particular zone, population density and the total building area are used to estimate household location choice. The coefficients table provides the parameters for each variable used in the regression, while the specification table defines the variable in python for interpretation by the operating platform. (Figure 5.10)

### 5.2.3 Datasets about Employment

The primary dataset which describes employment is the jobs table, which is a synthetically generated population of all jobs in Korle Bu, including their occupation, income, and location as well as variables

coefficient name	estimate	standard error	t statistic	variable name
ln_avg_hh_income	0.397204	0.0344578	11.5273	ln(building.aggregate(household.income,function=mean))
ln_emp_30_min	0.209228	0.0456355	4.58476	ln_bounded(building.disaggregate(urbansim_zone.zone.number_of_jobs_within_30_am_lov_time_threshold))
ln_households	0.100648	0.0219955	4.57586	ln(building.number_of_agents(household))
ln_job_density_zone	0.0123342	0.00221957	5.55703	building.disaggregate(zone.number_of_agents(job)/zone.area)/1000
ln_pop_density_zone	-0.0161921	0.0120318	-1.34577	building.disaggregate(zone.aggregate(household.persons)/zone.area)/1000
zone_area_bldg	-0.0397923	0.0183041	-2.17395	building.disaggregate(zone.area)

Figure 5.10 Household Relocation Choice Model Coefficients and Specifications

related to relocation probabilities such as number of hours worked per week and number of months in current job. The total number of jobs for the Korle Bu Region was determined from GSS estimates (as scaled for Korle Bu) and analysis of buildings and their use. Again using survey weights and the bootstrap method in Stata, a resample population of 79,856 jobs was created with statistical parameters which are nearly identical to the original sample population. (Appendix B) While in reality employment choices are made by businesses, in GAUS-KB jobs are the individual unit of analysis, which is equivalent to assuming that businesses are making individual choices about the location of each job. Future model development envisions an analogous set of business transition, relocation and location choice models. Figure 5.11 presents summary statistics of the original survey observations and the synthetically generated jobs table, including correlation amongst all variables.

The employment\_sectors table is used by GAUS-KB to define each job in accordance with its sector.

```

. sum

```

Variable	Obs	Mean	Std. Dev.	Min	Max
occupa	1382	561.4363	245.7125	11	933
industry	1376	5334.578	2261.297	111	9900
no_years	1384	8.185694	8.319943	0	51
no_months	1372	1.583819	3.026911	0	48
income	1381	1.51e+07	3.30e+07	0	5.76e+08
education	1270	4.759843	3.913339	1	16
sector	757	6.015852	2.695727	1	10
work_place	1383	6.445409	4.941014	1	16
no_coworkers	1293	32.90255	214.6276	0	4000
sex	1384	1.480491	.4997999	1	2
age	1384	37.55058	11.43919	10	85

```

. corr, wrap
(obs=631)

```

	occupa	industry	no_years	no_mon~s	income	educat~n	sector	work_p~e	no_cow~s	sex	age
occupa	1.0000										
industry	-0.4327	1.0000									
no_years	-0.1817	0.1402	1.0000								
no_months	0.0061	0.0219	-0.1675	1.0000							
income	-0.2398	0.0495	0.1517	-0.0164	1.0000						
education	-0.4798	0.2089	0.1144	0.0425	0.3414	1.0000					
sector	0.4558	-0.3277	-0.3747	-0.0583	-0.2160	-0.3846	1.0000				
work_place	0.1743	0.1504	-0.0844	-0.0450	-0.1497	-0.1979	0.2585	1.0000			
no_coworkers	-0.0510	-0.1054	0.0504	-0.0274	-0.0002	-0.0308	-0.1087	-0.1196	1.0000		
sex	-0.1199	0.1190	-0.0902	0.0563	-0.0884	-0.0448	-0.0072	0.1313	-0.0306	1.0000	
age	-0.1981	0.1230	0.6409	-0.1025	0.2129	0.1030	-0.2842	-0.0894	0.0317	-0.1865	1.0000

```

. sum

```

Variable	Obs	Mean	Std. Dev.	Min	Max
occupa	79413	489.1998	273.6928	11	933
industry	79413	5856.084	2239.604	122	9900
no_years	79413	8.526324	8.984244	0	51
no_months	79413	1.925415	3.67388	0	48
income	79413	1.77e+07	3.41e+07	0	5.76e+08
education	79413	6.001083	4.245492	1	16
sector	79413	5.960309	2.695429	1	9
work_place	79413	6.359551	5.283113	1	16
no_coworkers	79413	50.59373	240.5287	0	4000
sex	79413	1.278028	.4480299	1	2
age	79413	37.34745	11.03443	15	71

```

. corr, wrap
(obs=79413)

```

	occupa	industry	no_years	no_mon~s	income	educat~n	sector	work_p~e	no_cow~s	sex	age
occupa	1.0000										
industry	-0.4451	1.0000									
no_years	-0.1909	0.1504	1.0000								
no_months	-0.0017	0.0296	-0.1484	1.0000							
income	-0.2420	0.0603	0.1471	-0.0072	1.0000						
education	-0.4918	0.2139	0.1104	0.0493	0.3485	1.0000					
sector	0.4695	-0.3496	-0.3755	-0.0827	-0.2170	-0.3762	1.0000				
work_place	0.1758	0.1665	-0.0951	-0.0552	-0.1569	-0.2054	0.2897	1.0000			
no_coworkers	-0.0647	-0.0500	0.0612	-0.0074	0.0028	-0.0144	-0.1421	-0.1298	1.0000		
sex	-0.1294	0.1119	-0.0774	0.0429	-0.0764	-0.0331	-0.0313	0.1607	-0.0058	1.0000	
age	-0.1904	0.1294	0.6482	-0.0846	0.2200	0.1055	-0.2838	-0.1129	0.0326	-0.1612	1.0000

Figure 5.11 Jobs Table including a Comparison of Summary Statistics and Variable Correlations from GAMA Survey Observations (Top) and the Synthetically Generated Jobs Table for Korle Bu (Bottom)



ID	Sector	Frequency	Percent
1	Service-Institutional	5883	7.37
2	Industrial	12628	15.81
3	Office	19532	24.46
4	Retail	22322	27.95
5	Highway Retail	19491	24.41
	total	79856	100

Figure 5.12 Sectors: including the number of each type of job in Korle Bu

Service industries are primarily defined as institutional jobs such as those associated with hospitals, schools or other public services, while industrial jobs are generally associated with either a factory or workshop of varying sizes. Office sector jobs could include many different types of occupations such as real estate professionals, computer and network services, insurance sales, or a number of other types of businesses involving accounting or clerical functions to different degrees. Retail occupations include jobs located in hotels or restaurants as well as at locations which house stores or shops for selling general merchandise, while highway retail is further differentiated from retail from its location, which is either fixed or not fixed along street right-of-ways. Highway retail jobs may also be found in proximity to lorry parks and are primarily focused on the very active and dynamic informal economy. These types of jobs often locate in the smallest commercial buildings such as kiosks and stalls, or in neighborhood, district or regional markets (such as Malam Ata Market). (Figure 5.12)

The annual\_employment\_control\_totals table contains the number of jobs scheduled for potentially moving into the district for each of the simulation years. The table is structured according to the five employment sectors with the rate of increase in the number of jobs for each year determining the economic growth rate, with low scenarios set at a 2% rate of increase and high growth rates set at 4%. (Figure 5.13) The annual\_job\_relocation\_rates table contains the probability that a job in a particular sector will move at least once within a given simulation year. As estimated from GLSS data on employment, informal and retail type jobs have the highest probabilities of moving (25% and 20%), while institutional jobs have the lowest probability (10%). Industrial and office type jobs rates for relocation were set at 12.5 and 15% respectively.

The employment\_location\_choice\_model\_coefficients table and its associated specification table contain the variables and parameters used in the model to determine the new location for a job which has been scheduled to move. Dependent variables of number of employees within 30 minutes location, number of employees in zone, and population density are used to estimate the location choice for a moving job. The coefficients table provides the parameters for each variable used in the regression, while the specification table defines the variable in python for interpretation by the operating platform. (Figure 5.14)

### 5.2.4 Datasets about Infrastructure

The travel\_data table includes the travel distances and times to and from each zone (or plot) throughout Korle Bu. The travel data can be interpreted as the composite utility of going from one place to another given the available travel modes, which is estimated in terms of travel by motorized vehicle. The next phase of development for the GAUS-KB model will incorporate a fully developed transportation model that couples OPUS with MatSim.

The electricity\_demand table is an account of electricity consumed and recorded by each of the more than 15,000 meters found throughout the district. These meters have been spatially associated with each

sector_id	2005	2006	2007	2008	2009	2010	2011	2012	2013	2014	2015	2016	2017	2018	2019	2020	2021	2022	2023	2024	2025
1	5883	6001	6121	6243	6368	6495	6625	6758	6893	7031	7171	7315	7461	7610	7762	7918	8076	8238	8402	8570	8742
2	12628	12881	13138	13401	13669	13942	14221	14506	14796	15092	15393	15701	16015	16336	16662	16996	17336	17682	18036	18397	18765
3	19532	19923	20321	20728	21142	21565	21996	22436	22885	23343	23809	24286	24771	25267	25772	26288	26813	27350	27897	28454	29024
4	22322	22768	23224	23688	24162	24645	25138	25641	26154	26677	27210	27755	28310	28876	29453	30042	30643	31256	31881	32519	33169
5	19491	19881	20278	20684	21098	21520	21950	22389	22837	23294	23759	24235	24719	25214	25718	26232	26757	27292	27838	28395	28963
totals	79856	81453	83082	84744	86439	88167	89931	91729	93564	95435	97344	99291	101277	103302	105368	107476	109625	111818	114054	116335	118662

Figure 5.13 Employment Control Totals Table representing an Economic Growth Rate of 2%

coefficient name	estimate	standard error	t statistic	variable name
In_emp_30_min	0.209228	0.0456355	4.58476	In_bounded(building.disaggregate(urbansim_zone.zone.number_of_jobs_within_30_am_lov_time_threshold))
In_employees	1.11436	0.0102515	108.702	In_bounded(building.number_of_agents(job))
In_pop_density_zone	-0.0161921	0.0120318	-1.34577	building.disaggregate(zone.aggregate(household.persons)/zone.area)/1000

Figure 5.14 Employment Location Choice Model Coefficients and Specifications

building location and joined to the data tables received from the Electricity Company of Ghana for the year 2007. A regression model estimating electricity demand at the zone level is used in the electricity demand model to estimate consumption per year in terms of the composition of households, jobs and other attributes for each of the 280 zones. (Figure 5.15)

### 5.3 Models

The Greater Accra Urban Simulation – Korle Bu district is comprised of a number of different models which project agent decisions regarding land, households, employment, and land development. Within the platform itself (OPUS), each GAUS-KB model is a Python Class which has inherited its properties from an Urbansim Parent Class (which also inherits its set of functionality and structure from opus\_core). These urbanism child classes of the opus\_core includes a number of: discrete choice models, a set of agents which make choices from a finite set of possibilities or alternatives based on probabilities derived from utilities computed from given variables and coefficients; regression models, which implement a regression procedure; and allocation models, which distribute given quantities according to weights while meeting capacity restrictions. GAUS-KB also includes a number of simple models which compute a variable on a dataset such that the result becomes a primary attribute. As each model completes its simulation run, data is updated and stored for that particular year, for output and joining to individual plots in the GAUS-KB geodatabase. A single simulation run continues for each year until the simulation period has been completed.

#### 5.3.1 Land Models

The Real Estate Price Model uses real estate prices as the indicator of the match between demand and supply of land at different locations for different land uses. This role is important within the urban simulation to the rationing of land and buildings to consumers based on preferences and ability to pay. Since prices enter the location choice utility functions for jobs and households, adjustment in prices will

source	SS	df	MS			
Model	9.2950e+11	10	9.2950e+10	Number of obs =	267	
Residual	2.2927e+12	256	8.9559e+09	F( 10, 256) =	10.38	
Total	3.2222e+12	266	1.2114e+10	Prob > F =	0.0000	
				R-squared =	0.2885	
				Adj R-squared =	0.2607	
				Root MSE =	94636	

Units	Coef.	Std. Err.	t	P> t	[95% Conf. Interval]	
households	1031.323	782.4942	1.32	0.189	-509.6223	2572.268
persons	-472.299	486.0457	-0.97	0.332	-1429.456	484.8581
workers	-142.6345	514.79	-0.28	0.782	-1156.397	871.128
children	609.9626	599.723	1.02	0.310	-571.0562	1790.981
jobs	528.4578	800.6546	0.66	0.510	-1048.25	2105.166
sector_id1	-4701.427	1591.696	-2.95	0.003	-7835.913	-1566.942
sector_id3	-1165.414	1053.497	-1.11	0.270	-3240.039	909.2104
sector_id4	750.1572	1176.905	0.64	0.524	-1567.49	3067.805
sector_id5	343.0444	1145.637	0.30	0.765	-1913.03	2599.118
income	-2.270184	10.04528	-0.23	0.821	-22.05208	17.51172
_cons	52452.58	18653.95	2.81	0.005	15717.84	89187.31

Figure 5.15 Regression model of Electricity Demand per Zone

alter location preferences. Similarly an adjustment in property value will alter the preference of developers. The model predicts the average value per unit for each building, applied as a single dwelling for residential land uses or a single enterprise for commercial, industrial, and institutional land uses.

Figure 5.16 presents building value results from the Real Estate Price Model (run in terms of a low population and economic growth rate scenario) in the area of Sabon Zongo at three year intervals beginning in 2007. Perhaps the most obvious result is that building values fluctuate only slightly in this area, indicating a relatively entrenched population. Considering the low household incomes and low mobility rates it can be concluded that the numerous multi-family dwellings are rentals which are income produces for landlords, who may or may not have legal title to the property. With the relatively stable value and low mobility, it is questionable how much residents benefit from their location in central Accra and their proximity to numerous employment opportunities. Instead it is more likely that these real estate property values are projecting a representation of the potential rental income collected by landlords from these very dense, mostly high density residential land uses. Residential densities in this particular area can range upwards from 65 dwelling units/acre with average household sizes of 4 persons and including a remarkable amount of site coverage since nearly all residential structures are a single story in height (less than 20 feet). Furthermore, open space is nearly non-existent and little or no consideration has been for public service easements such as water, sewer or other utilities, likely as result of the intention to optimize inhabitable living spaces for increased rental income potential. Consideration for identifying the front and back sides of structures is also difficult with many compound structures gaining access from street rights-of-way with individual access to family dwellings within the compound structure from a central courtyard. The diversity of values projected by the model also indicates that space does exist for newcomers, but since property values remain nearly constant, it is more likely that these spaces are available for individual immigrants who have moved to the area and are in the process of adopting new associations with existing householders or perhaps taking the place of a previous individual who had decided to move elsewhere rather than a wholesale change of family inhabitation within a single dwelling. It is also possible that the diversity of values indicates that property rights either in terms of ownership or the right to administer a property is unclear or under contest and presents an obstacle to inhabiting a dwelling. Finally, these real estate property projection may also indicate that some of the dwellings are simply uninhabitable or very undesirable either due to the condition of the stucture, its location within the neighborhood or a combination of both.

### 5.3.2 Household Models

The Household Transition Model creates and removes households in Korle Bu based on the annual\_household\_control\_totals table, which provides target quantities of household types by year in terms of the number of persons residing in those households. The model iterates over the different defined marginal characteristics, determines the number of households belonging to that household type, and compares the control total for that particular type and year. If the difference is positive, new households are created, negative, households are removed, and if the difference is zero, nothing occurs. New households are combined with those that have decided to relocate, and are then queued for input to the Household Location Choice Model. Households scheduled to be removed from a particular type are randomly sampled for deletion. Input from this table is the primary source for determining the rate of demographic growth, with the low growth scenario set at a 2% rate of increase, medium 3%, and high 4% per year from 2006 until 2025. In Accra, household sizes range from 1 to 12 persons. (Figure 5.9)

The Household Relocation Model predicts the probability that a particular household will move from its current location or remain there for that particular year. This model determines which households in Korle Bu will be scheduled for relocation based on the given probabilities for each household type found



Figure 5.16 Real Estate Price Model outputs per Building for the years 2007 to 2022 in Sabon Zongo, log of average unit value

in the annual\_relocation\_rates\_for\_households table. These mobility rates have been estimated from the work by Bertrand and Delaunay as previously described and provide the probabilities that a household with given characteristics will relocate at least once within the time span of a single year. The run method iterates over the households table using the rate set, and determines for each household if it will move or not. As households are identified for relocation, they are combined and queued with new households from the transition model for input into the Household Location Choice Model. Households which move outside of the Korle Bu district are deleted. (Figure 5.3)

The Household Location Choice Model predicts the probability that a household which is either new to the district or has moved from another location within Korle Bu will be located in a particular residence (Figure 5.17) The number of households available to locate within a building depends on the number of available units, and as new or relocated households are matched to an available unit, the data is updated in the buildings table. The model predicts the likelihood of a household locating in a particular building, using six variables: average household income within the zone, proximity to jobs, number of households within the zone, job and population density as well as open space within the round where the residential structure is located. The model has been specified to estimate household preference to locate in zones (plots) where household incomes and access to the highest number of jobs within 30 minutes of the home are highest. The number of households and job density within the round also positively influence housing bids, while population density and lack of open space within the round negatively influence housing bids. (Figure 5.10)

Figures 5.18 illustrates the number of households located in each of the 280 zones throughout Korle Bu as predicted by GAUS-KB for the years 2006 to 2025 in terms of a low demographic and economic growth rate. This spatial representation of the model projection indicates the largest number of households will be located in Sabon Zongo with round 030-080 absorbing the largest number and demonstrating the most significant growth during the 20 year period with an increase of approximately 3000 new households. The adjacent round 030-070, which is in Zoti, trends towards having the second largest number of households, and in general the block comprising these four rounds (Zoti, Sabon Zongo and Abossey Okai) exhibit a strong trend towards very high densities. The second hotspot where household population demonstrates large numbers and growth is in the area of Adedenkpo, particularly round 010-040 in the southern half, which is adjacent to Korle Dudor where large numbers of households also trend in the plots (zones) along the shared border. The model projects that in the year 2017, population growth will extend into the northern plots comprising Adedenkpo or the area often referred to as “Sodom and Gomorrah.” As with

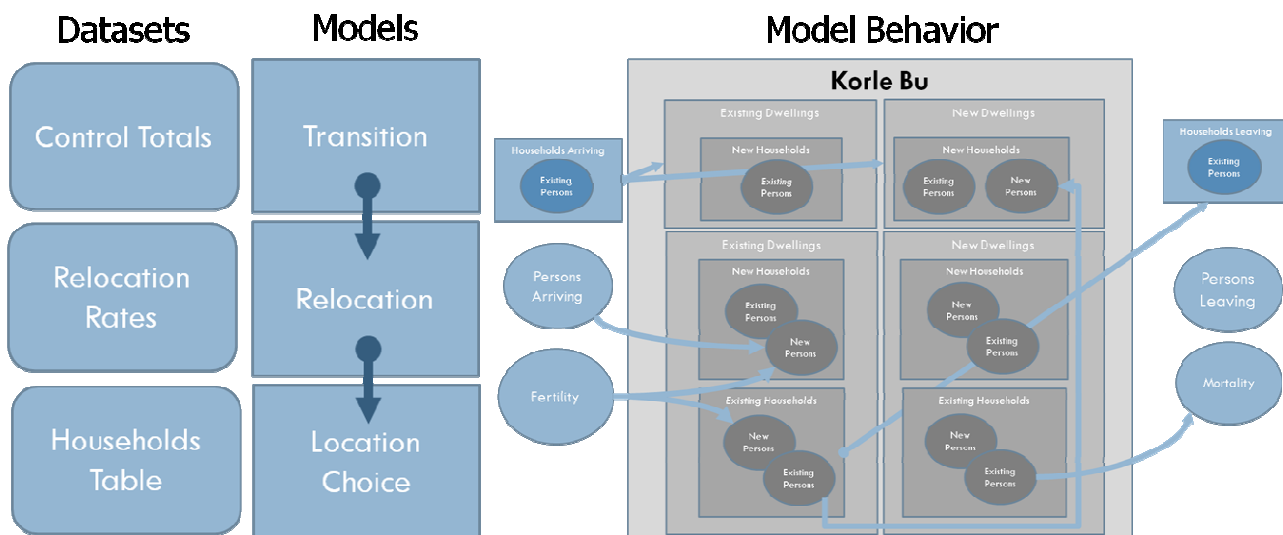

Figure 5.17 Household Datasets, Models, and Associated Behavioral Structure of Location Choice Model



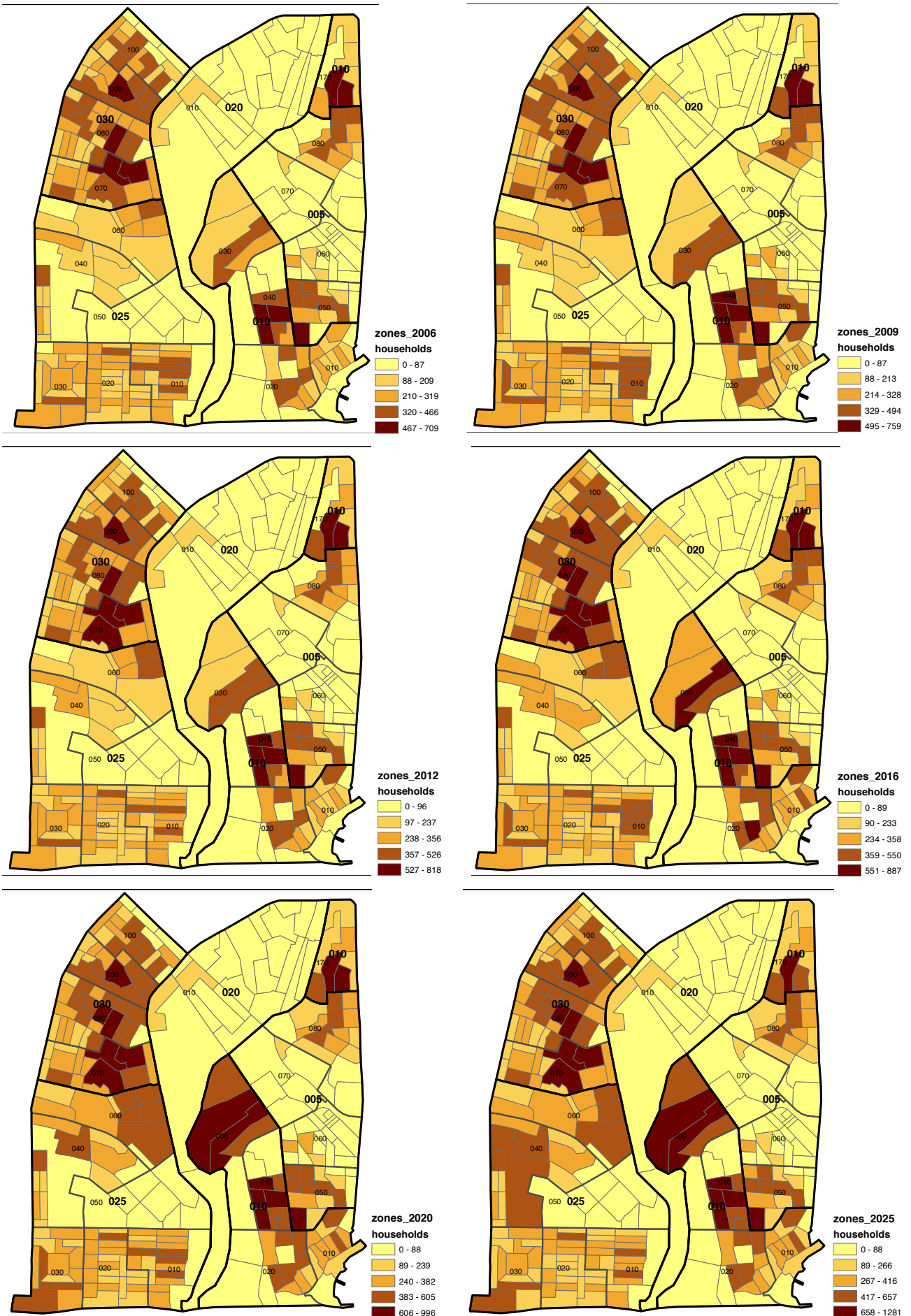
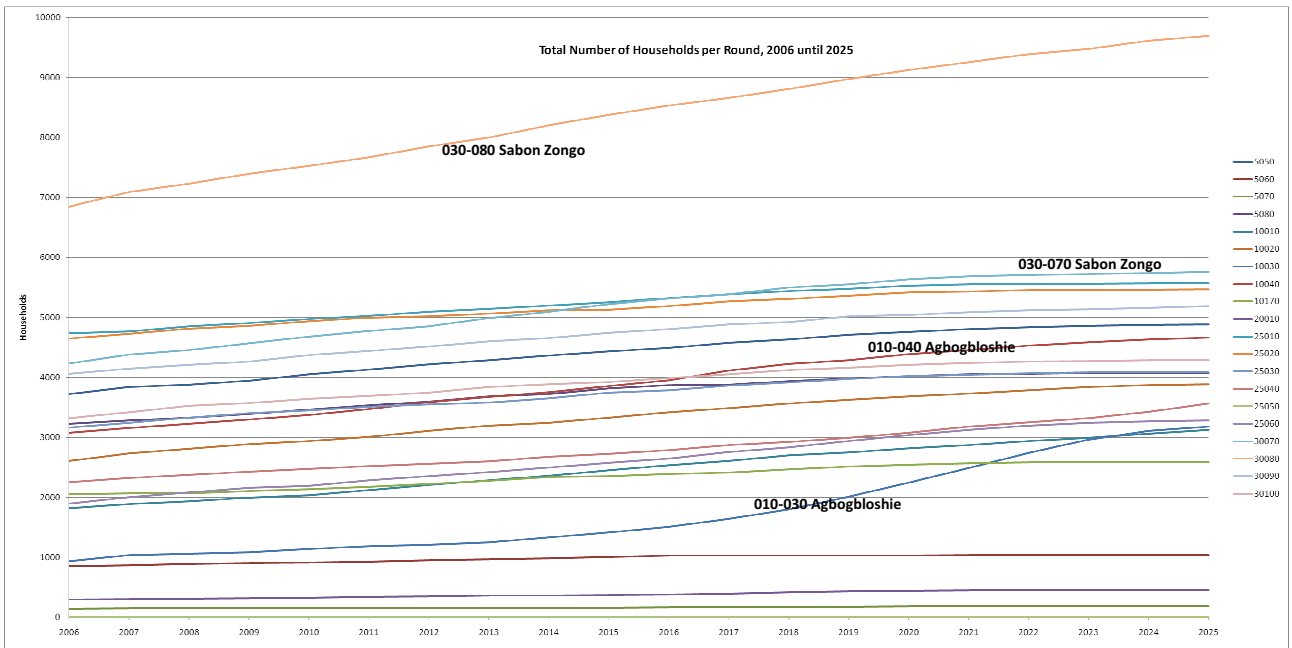

Figure 5.18 Household Location Choice Model outputs for the years 2006 til 2025: total number of households per Zone



round	2006	2007	2008	2009	2010	2011	2012	2013	2014	2015	2016	2017	2018	2019	2020	2021	2022	2023	2024	2025
5050	3721	3838	3878	3942	4056	4131	4212	4283	4361	4433	4494	4576	4633	4708	4754	4803	4832	4859	4876	4880
5060	848	866	889	905	913	928	953	969	984	1008	1031	1031	1025	1026	1029	1035	1036	1038	1039	1038
5070	138	144	145	149	149	151	154	157	156	157	164	168	169	173	174	174	174	174	174	174
5080	3228	3283	3325	3390	3467	3532	3598	3682	3719	3810	3868	3878	3940	3985	4020	4050	4060	4077	4077	4077
10010	1821	1890	1932	1994	2033	2117	2205	2280	2357	2452	2535	2607	2697	2746	2817	2869	2939	2992	3065	3121
10020	2610	2727	2805	2885	2937	3008	3109	3196	3242	3328	3416	3489	3564	3625	3684	3732	3780	3835	3866	3883
10030	936	1035	1059	1084	1137	1180	1210	1248	1329	1414	1507	1640	1795	2009	2242	2482	2739	2963	3108	3176
10040	3076	3159	3225	3298	3372	3470	3592	3675	3753	3850	3953	4112	4220	4284	4382	4457	4535	4583	4632	4662
10170	2050	2062	2067	2106	2138	2177	2218	2276	2332	2352	2391	2412	2471	2513	2541	2571	2580	2585	2589	2588
20010	294	299	309	315	323	339	347	360	365	372	381	394	415	436	439	447	452	453	451	454
25010	4735	4761	4853	4906	4975	5031	5101	5144	5200	5253	5321	5384	5438	5476	5534	5556	5557	5564	5572	5573
25020	4651	4728	4809	4855	4937	4997	5019	5066	5123	5131	5192	5266	5307	5357	5418	5432	5451	5455	5464	5466
25030	3160	3238	3329	3401	3449	3513	3549	3584	3650	3743	3784	3860	3913	3978	4019	4047	4069	4085	4085	4086
25040	2253	2318	2371	2431	2478	2520	2560	2596	2677	2725	2781	2866	2925	2997	3077	3177	3248	3321	3430	3564
25050	0	0	0	0	0	0	0	0	0	0	0	0	0	0	0	0	0	0	0	0
25060	1898	2006	2077	2154	2191	2282	2350	2420	2495	2576	2643	2754	2833	2938	3042	3126	3192	3240	3266	3278
30070	4229	4379	4458	4574	4680	4775	4850	4989	5100	5200	5314	5385	5501	5557	5636	5688	5706	5726	5740	5761
30080	6849	7090	7233	7397	7525	7674	7848	8002	8207	8374	8531	8661	8812	8974	9126	9256	9388	9479	9615	9700
30090	4057	4144	4204	4262	4373	4440	4515	4605	4654	4740	4807	4877	4921	5022	5045	5086	5120	5134	5162	5187
30100	3320	3418	3529	3573	3640	3689	3746	3834	3883	3919	3993	4054	4120	4160	4206	4235	4265	4267	4283	4288
district	53874	55385	56407	57621	58773	59954	61136	62366	63587	64857	66106	67414	68699	69964	71185	72233	73123	73830	74494	74956

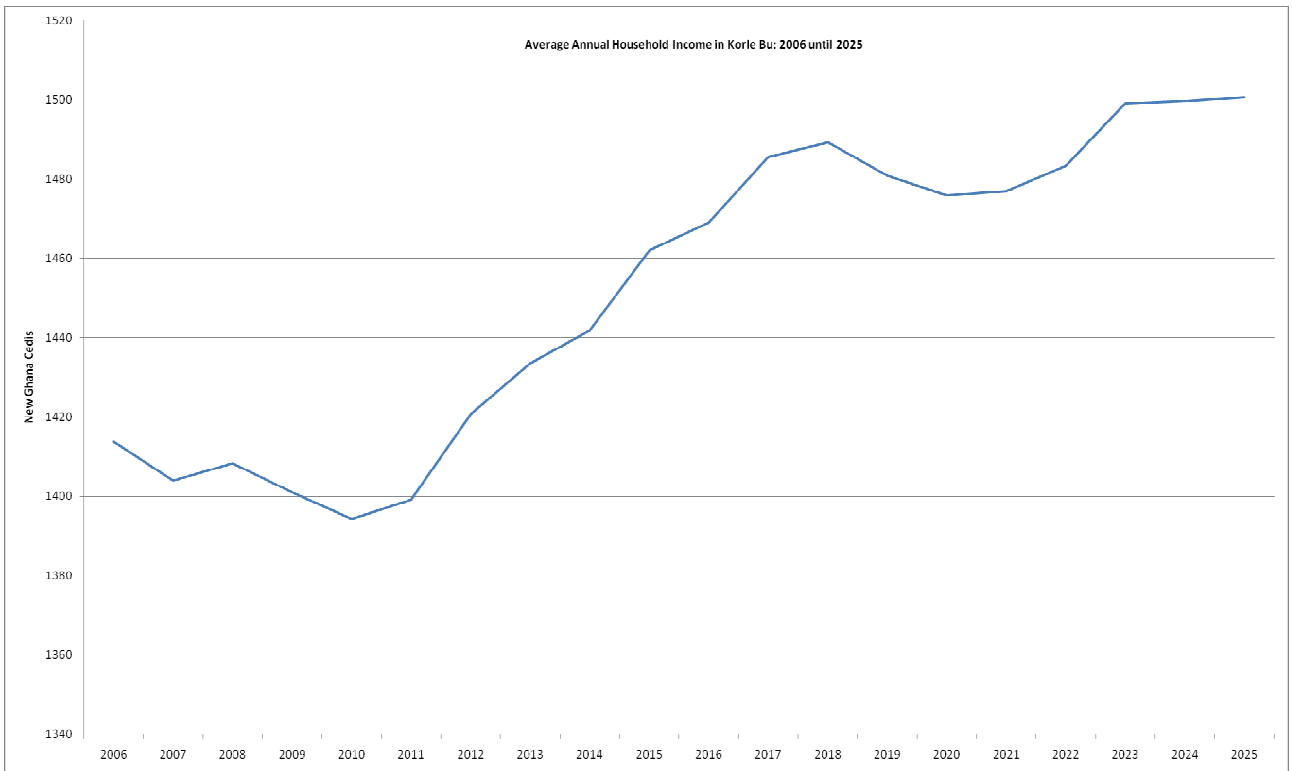

Figure 5.19 Total Number of Households Per Zone (Top) and Average Annual Income in District (Bottom) for the simulation years 2006 til 2025

the real estate price model analysis of Sabon Zongo, the Household Mobility simulations present questions related to population growth and if any real poverty reduction can be expected if business-as-usual in Korle Bu continues. Under the low economic and demographic growth scenario, average household income increases by only 100 GHGs (1400 to 1500) over the twenty year time span from 2006 to 2025. (Figure 5.19)

### 5.3.3 Employment Models

The Employment Transition Model creates and removes jobs in Korle Bu based on the annual\_employment\_control\_totals table which gives target quantities of the number of persons employed by sector for each simulated year. (Figure 5.13) The model iterates over the different defined marginal characteristics and determines the number of jobs that belong to that sector. It then compares that number to the control total for that particular sector and year. If the difference is positive, new jobs are created, if it is negative, then jobs are removed, if it is zero, nothing occurs. New jobs are combined with those that have decided to relocate, and are then queued for input in the Employment Location Choice Model. Jobs which are to be removed from a particular sector are randomly sampled for deletion. By changing the control totals table, low, medium and high economic growth rates of aggregate employment by sector have been forecast. Input from this table is the primary source for determining the rate of economic growth, with low, medium and high growth rate scenarios set at 2%, 3% and 4% per respectively. Data from the GLSS5 which was based on the World Bank Industrial Classification System have been aggregated to match the classification system used in the basic version of the employment and business models. (Figure 5.12)

The Employment Relocation Model predicts the probability that a particular job will move from its current location or remain there for that particular year. This model determines which jobs in Korle Bu will be scheduled for relocation based on the given probabilities for each sector found in the annual\_relocation\_rates\_for\_jobs table. These probabilities were estimated from variables related to job mobility in the GLSS5, including those most likely considered to be part of the informal sector. The run method iterates over the jobs table using the rate set, and determines for each job if it will be moved or not. As jobs are identified for relocation, they are combined and queued with new jobs from the transition model for input into the Employment Location Choice Model. Jobs which will move outside of Korle Bu are deleted.

The Employment Location Choice Model predicts the probability that a job which is either new to the

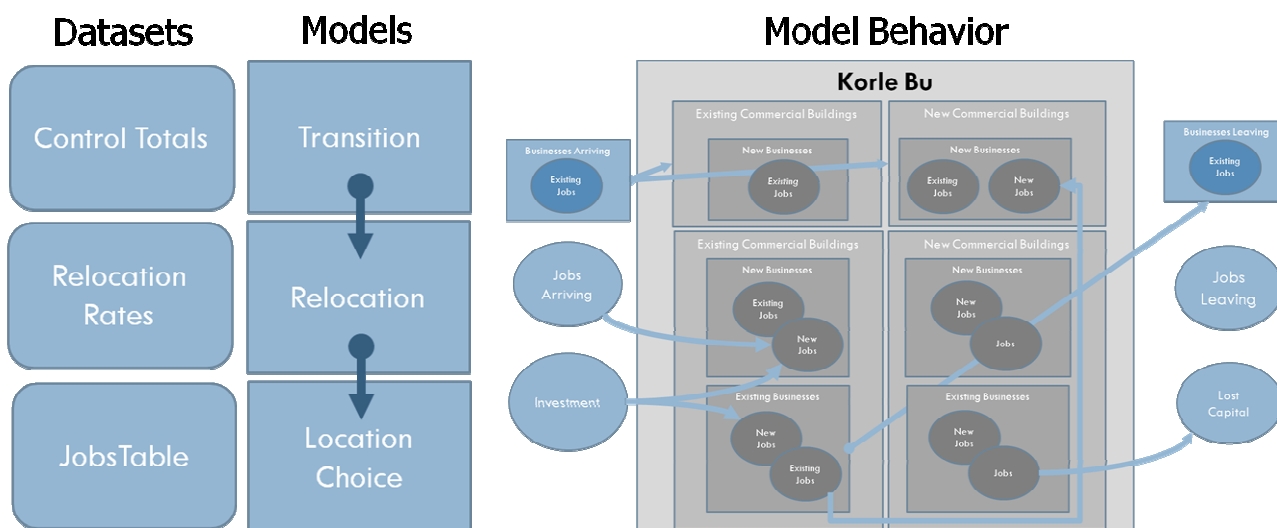
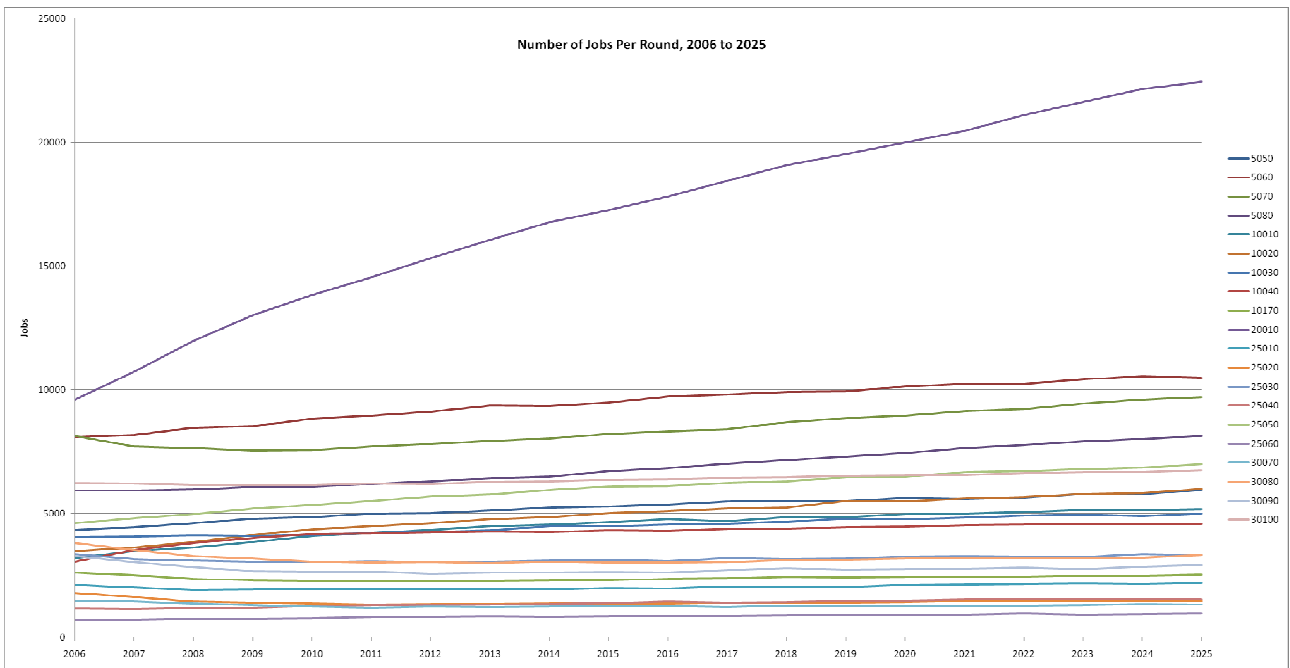

Figure 5.20 Employment Datasets, Models, and Associated Behavioral Structure of Location Choice Model



Figure 5.21 Employment Location Choice Model outputs for the years 2006 til 2025: total number of jobs per Zone



round	2006	2007	2008	2009	2010	2011	2012	2013	2014	2015	2016	2017	2018	2019	2020	2021	2022	2023	2024	2025
5050	4346	4450	4597	4792	4850	5001	5019	5118	5234	5268	5369	5487	5494	5509	5625	5589	5649	5797	5781	5943
5060	8094	8172	8452	8532	8822	8948	9123	9360	9341	9485	9735	9813	9903	9931	10135	10228	10236	10420	10537	10474
5070	8143	7711	7649	7545	7559	7709	7816	7922	8024	8215	8318	8401	8678	8844	8955	9129	9226	9435	9612	9714
5080	5941	5934	5977	6064	6094	6188	6303	6418	6481	6704	6825	7019	7156	7294	7451	7650	7773	7905	8016	8133
10010	3196	3475	3617	3849	4098	4216	4338	4472	4542	4638	4772	4693	4844	4844	4980	4993	5044	5135	5133	5168
10020	3472	3632	3848	4142	4363	4485	4599	4768	4858	5010	5096	5188	5232	5508	5489	5608	5673	5795	5824	5987
10030	4044	4082	4118	4096	4128	4213	4260	4317	4478	4490	4538	4578	4657	4782	4764	4837	4901	4943	4895	4996
10040	3062	3520	3803	4017	4175	4205	4238	4271	4252	4317	4289	4377	4378	4448	4468	4518	4534	4566	4566	4587
10170	2595	2510	2369	2293	2280	2280	2262	2283	2307	2298	2368	2370	2445	2429	2432	2445	2439	2479	2480	2514
20010	9597	10731	11977	13013	13827	14542	15312	16060	16760	17258	17820	18447	19073	19517	19985	20463	21091	21630	22168	22437
25010	2117	2014	1905	1929	1943	1944	1937	1951	1924	1996	1970	2062	2057	2038	2122	2128	2147	2167	2158	2203
25020	1794	1618	1445	1404	1364	1314	1342	1345	1365	1355	1364	1409	1395	1406	1412	1451	1434	1432	1435	1461
25030	3366	3155	3092	3044	3024	3078	3030	3053	3102	3143	3077	3189	3148	3173	3258	3281	3258	3244	3367	3325
25040	1160	1126	1168	1201	1252	1293	1301	1325	1335	1381	1440	1393	1426	1466	1488	1516	1535	1525	1529	1529
25050	4598	4802	4974	5189	5337	5495	5680	5765	5953	6087	6123	6245	6302	6459	6474	6669	6714	6790	6855	7000
25060	692	713	749	755	762	805	819	849	826	842	851	857	868	891	900	901	951	908	929	934
30070	1490	1435	1367	1291	1234	1201	1232	1206	1227	1228	1247	1223	1272	1274	1252	1268	1283	1305	1340	1314
30080	3817	3523	3273	3167	3050	3005	3029	2984	3059	3007	3012	3037	3124	3140	3181	3207	3191	3214	3212	3212
30090	3284	3041	2824	2669	2653	2644	2571	2611	2613	2631	2612	2703	2779	2721	2739	2721	2810	2745	2846	2906
30100	6228	6218	6163	6142	6153	6207	6205	6276	6306	6355	6386	6449	6467	6530	6534	6551	6620	6658	6658	6755
district	81036	81862	83367	85134	86968	88773	90416	92354	93987	95708	97212	98940	100698	102204	103644	105208	106509	108093	109341	110714

Figure 5.22 Total Number of Jobs Per Round for the simulation years 2006 til 2025

district or has moved from another location within Korle Bu will be located in a particular place of business (Figure 5.20) The number of jobs available to locate within a building depends on the number of available spaces, and as new or relocated jobs are matched to an available unit, the data is updated in the buildings table. The model predicts the likelihood of a job locating in a particular building, using three variables: proximity to jobs, number of jobs within the round, and number of potential employees. The model has been specified to estimate job preference for locating in zones (plots) where access to the highest number of potential employees is highest. Population density has a slight negative influence on job choice. (Figure 5.14)

Figures 5.21 illustrates the number of jobs located in each of the 280 zones throughout Korle Bu as predicted by GAUS-KB for the years 2006 to 2025 in terms of a low demographic and economic growth rate. This spatial representation of the model projection indicates the largest single concentration of jobs will be in round 020-010, which primarily represent the South Industrial Park. This particular round is projected to outpace all other rounds over the twenty year period by more than double. The adjacent round 005-070, Agbogbloshie, also exhibits strong growth in number of jobs, which interestingly appears to be connected to the part of Adedenkpo known as “Sodom and Gomorrah.” A third much smaller hotspot is located within round 025-050 and appears to be associated with a projected expansion of the Korle Bu Teaching Hospital. (Figure 5.22)



Construction cost per unit	Description	Building Type	Building m2 per Unit	Building Type ID	land m2 minimum	Plot Type	Template ID
50	compound house	mfr_condo	30	1	500	1	1
75	flat	mfr_apartment	50	1	500	1	1
100	self contained house	sfr_home	120	1	500	1	1
85	mfr_apartment	mfr_apartment	50	1	500	1	1
45	com	com	30	2	200	1	1
50	ind	ind	1000	3	2000	2	1

Figure 5.23 Basic Development Types for GAUS-KB

### 5.3.4 Land Development Models

The development\_templates table represents land developments of a traditional vernacular in basic terms. The Development Project Location Choice Model projects real estate development as a process where real estate property developers seek the best available site for their real estate projects. This model has been implemented in a very basic form to project traditional land development in Korle Bu based on existing types. During the next phase of developing GAUS, this model will be improved to better represent the decisions of property developers including their potential return on an investment with regard to a more diverse portfolio of potential land development types (as observed in Accra).

## 5.4 Electricity Demand Projections

Figure 5.15 presents the results of a regression model which has been used to project electricity demand based on the composition of demographic and economic characteristics comprising each of the 280 zones in Korle Bu for each year from 2006 to 2025. The dependent variable, which is measured as units of electricity consumed, projects total number of kilowatt-hours demanded, as determined by the number of households and their composition in terms of persons, workers, children and average annual income as well as the total number of jobs and number of jobs per sector. The model then applies the regression coefficients to the output from the household and employment mobility models to estimate total projected electricity demand for each individual zone (plot) in terms of the total amount of kilowatt-hours consumed for that particular simulation year.

Figure 5.24 provides a spatial illustration of projected electricity demand by zone (plot) from 2006 until 2025 in terms of a low population and economic growth rate. The projection largely reflects the results of the employment mobility models, with the area projected to exhibit both the largest demand and increase in demand for electricity being round 020-010 or the South Industrial Park, which increases from a bit more than 3,000,000 kilowatt-hours to well over 6,000,000 per year. Interestingly, the Sabon Zongo round, 030-080, is projected by the model to be the second largest consumer of electricity surging from 3,000,000 to 3,935,000 kWhs per year. In more general terms, the plots comprising Agbogbloshie as well as those in the northern part of Adedenkpo trend towards hotspots of high end consumption patterns throughout the urban simulation time period. One additional hotspot to consider for electricity demand is the plot where the Korle Bu Teaching hospital is located.

Figure 5.25 demonstrates projected electricity demand per round and year including a table of actual simulated consumption. The chart clearly illustrates the importance of the South Industrial Area in terms of electricity demand but also charts the growth of Sabon Zongo as the second largest consumer. From there, the results indicate that plots along the western side of Kwame Nkrumah Boulevard along will have the highest demand, with rounds 005-060 and 005-080 each projected to consume more than 3,000,000 kWhs per year by 2025 and round 005-050 not far behind at more than 2,500,00 kWhs. One other area of interest is the Abossey Okai neighborhood which is largely commercial along Winneba Road and Obtsey Lamptey Circle. While Abossey Okai transitions to Sabon Zongo to the south and those high density residential land uses, in this particular area the retail and highway retail (informal sector) jobs appear to positively impact electricity demand with projections of more than 2,750,000 kWhs per year predicted by 2025.

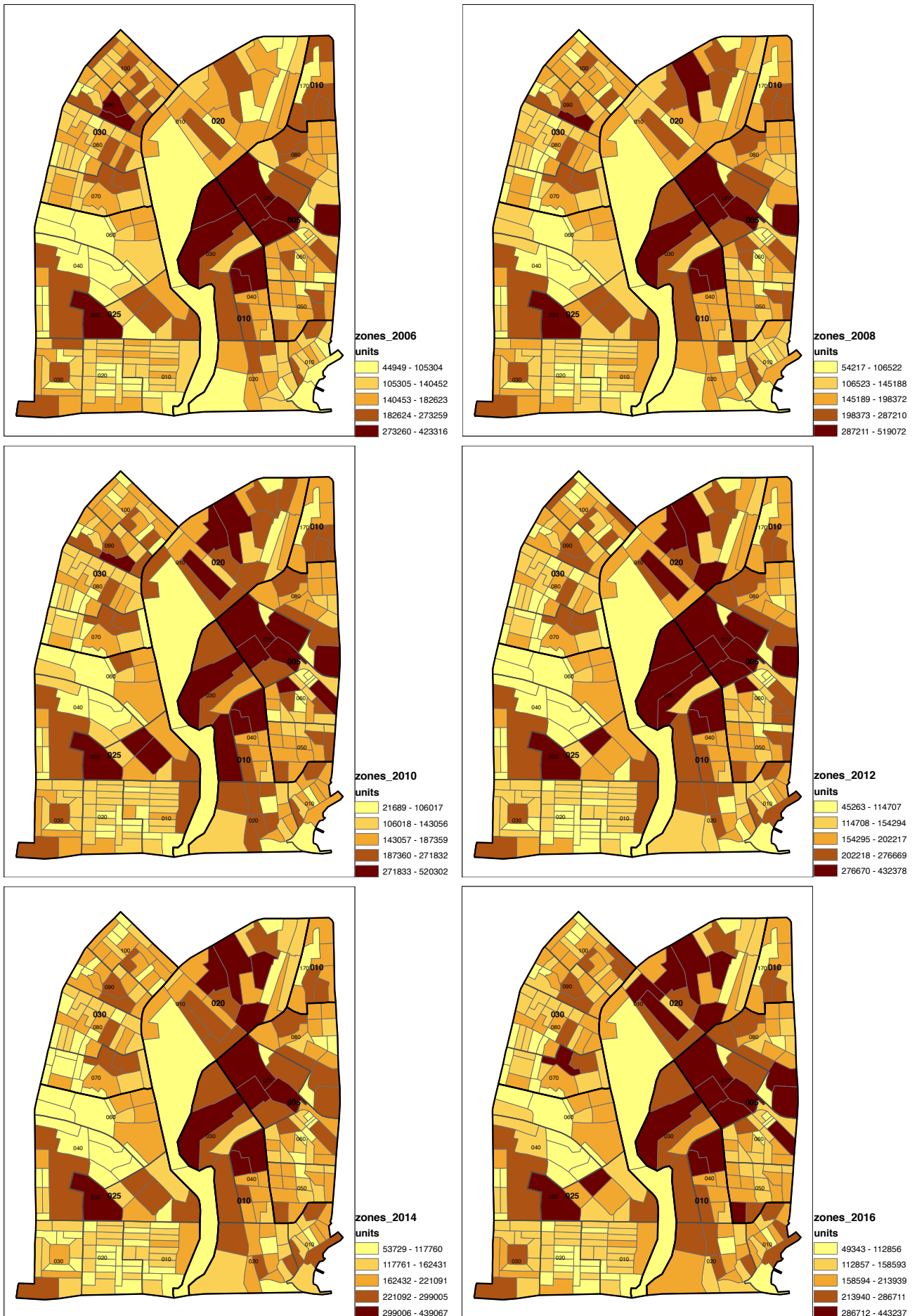

Figure 5.24 Annual Projected Electricity Demand in total Kilowatt-hours (kWh) per Zone for the Simulation Years 2006—2025



Figure 5.24 (continued) Annual Projected Electricity Demand in total Kilowatt-hours (kWh) per Zone, 2006—2025

Figure 5.26 illustrates the GAUS-KB projection of electricity demand for the entire district. This graph aggregates all demand in the district and presents total projected consumption in kilowatt-hours for each year in terms of the low population and economic growth rate. The graph clearly illustrates that electricity demand is projected to increase by nearly 17% during the twenty year period, with total number of kWhs increasing from almost 42,000,000 to 50,000,000. Considering that the approximately 200,000 persons inhabiting Korle Bu represent only about 0.008% of Ghana’s total population, this is a significant amount of projected consumption compared to overall totals for the country (once demand from the Valco aluminum smelter is removed).

This electricity demand projection clearly indicates the significance of industrial consumption in Korle Bu. It also presents some other interesting results, including projecting increased consumption patterns in Agbogbloshie as well as Adedenkpo and along the west side of Kwame Nkrumah Boulevard. Sabon Zongo, which is a high density residential area, also projected very high demand for future electricity consumption, which seems to indicate it is functionally more similar to commercial and industrial zones rather than the other residential areas in the district such as Korle Gonno, Ussher Town or James Town.

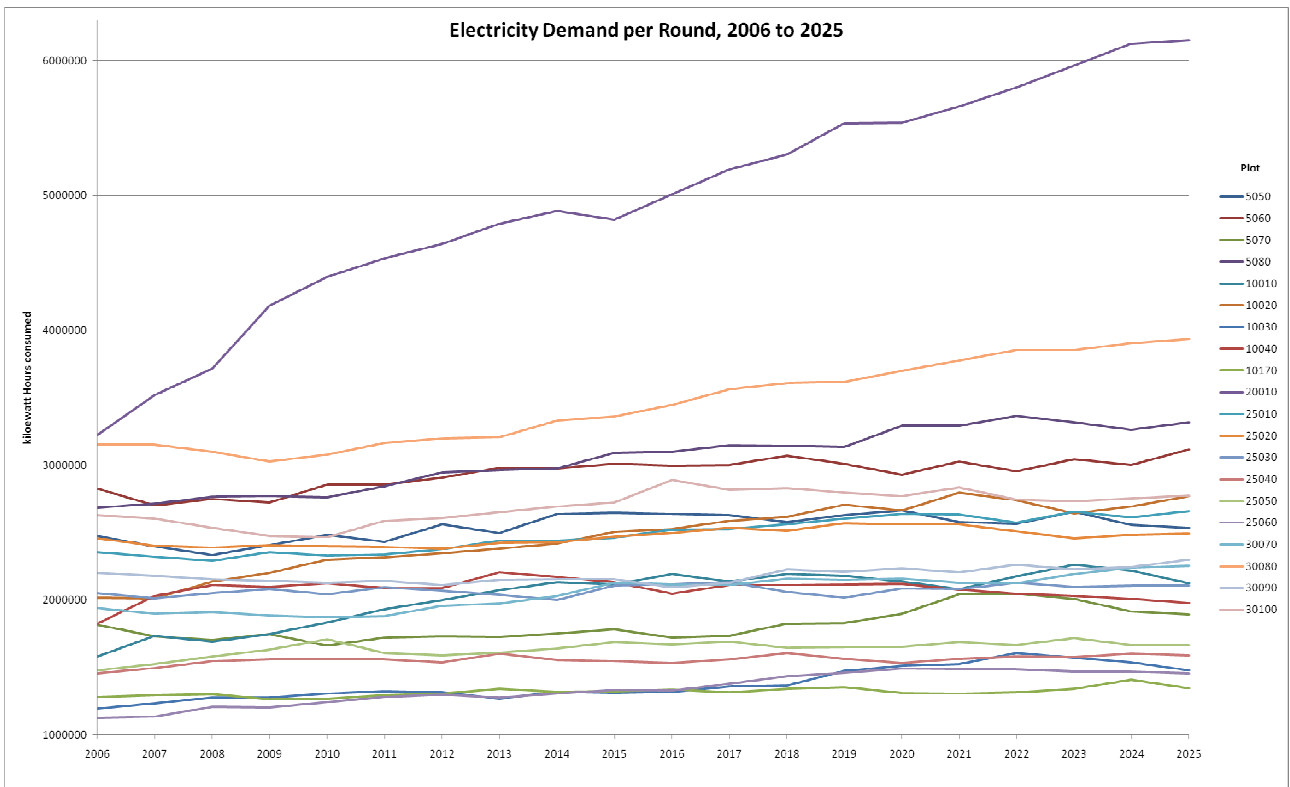

round	2006	2007	2008	2009	2010	2011	2012	2013	2014	2015	2016	2017	2018	2019	2020	2021	2022	2023	2024	2025
5050	2475647	2396644	2334494	2407654	2485256	2434523	2562581	2498399	2636407	2644860	2639745	2631480	2576020	2627932	2665839	2578610	2566308	2656393	2556182	2534211
5060	2828168	2701339	2748211	2724663	2857178	2855256	2906627	2980439	2977121	3012543	2998184	3000710	3072387	3008417	2929893	3029758	2956269	3045636	3004006	3119318
5070	1818129	1732489	1704124	1747734	1663167	1723514	1731779	1726673	1753770	1781574	1720819	1736055	1822663	1828449	1898572	2041265	2047562	2010225	1913480	1892520
5080	2684044	2717245	2765936	2769043	2761304	2843057	2946782	2964414	2976346	3089926	3098496	3148051	3145332	3133577	3293232	3292143	3364652	3318114	3261151	3319368
10010	1581873	1733586	1691917	1746453	1832699	1931341	1999845	2072369	2132910	2117500	2192615	2135677	2194853	2177893	2135357	2083379	2173591	2261039	2218599	2123066
10020	2018308	2013836	2136816	2203512	2298928	2317517	2348510	2380148	2420234	2505133	2524998	2586277	2618359	2707517	2664467	2794558	2741309	2640782	2695564	2771651
10030	1196873	1234615	1275456	1278573	1305419	1322778	1314591	1268049	1318203	1312547	1320597	1358739	1368503	1472346	1512934	1526077	1608014	1570722	1535756	1477204
10040	1823868	2031547	2111436	2097954	2124322	2088692	2091969	2203700	2170186	2121316	2048775	2111857	2110865	2113676	2118275	2075599	2047822	2031755	2010582	1977413
10170	1281640	1292441	1301878	1263922	1267615	1292257	1306245	1341756	1319897	1321925	1334853	1313609	1339444	1351705	1312298	1304552	1315093	1338859	1407879	1343744
20010	3224525	3518786	3714881	4184651	4395564	4535967	4641168	4793504	4886041	4822367	5009211	5194012	5305673	5537234	5539444	5659626	5801419	5963657	6127944	6151035
25010	2355777	2323090	2293217	2355592	2330578	2340512	2377667	2439136	2442745	2461877	2523075	2526602	2561796	2602996	2637125	2633512	2574412	2657086	2613594	2680399
25020	2457573	2402995	2389180	2406687	2398602	2393731	2380752	2422034	2427048	2472898	2498685	2537241	2514815	2568464	2562119	2562148	2509457	2459891	2483334	2492675
25030	2052512	2011914	2050563	2081928	2042705	2096447	2070163	2038194	2001637	2106558	2116050	2134142	2061813	2018516	2086597	2083587	2127094	2099847	2106343	2106911
25040	1457701	1495103	1544225	1560087	1557713	1558962	1539223	1600166	1556508	1548114	1531995	1561081	1606225	1563750	1534677	1561705	1578892	1576802	1600042	1588115
25050	1476317	1522807	1578680	1631437	1709330	1604830	1590135	1610512	1639671	1686739	1669655	1689823	1645045	1648894	1654834	1686769	1665470	1715978	1665372	1661017
25060	1126674	1135177	1206665	1202784	1243763	1279678	1296028	1275669	1307705	1330426	1328163	1377908	1434077	1459835	1490303	1485728	1486497	1471365	1468518	1454761
30070	1940467	1898507	1910188	1883565	1870001	1879126	1958358	1972646	2028324	2126609	2114473	2110702	2158971	2149614	2159795	2129157	2124016	2192246	2241801	2254848
30080	3152741	3152643	3101512	3026372	3077750	3166448	3197096	3207131	3333067	3362524	3447797	3563498	3611270	3617512	3701429	3775589	3854900	3852540	3907388	3935220
30090	2199859	2179031	2154904	2142537	2130107	2141529	2112667	2150403	2154061	2153221	2093064	2129369	2228483	2211500	2237592	2204001	2262008	2225991	2242166	2298019
30100	2628097	2605203	2534831	2476678	2465025	2587484	2610067	2651022	2694079	2722244	2891991	2819027	2831002	2797865	2769152	2833309	2746105	2732602	2753382	2775885

Figure 5.25 Electricity Demand per Round, Projection 2006 to 2025

While this electricity demand model for Korle Bu indicates the South Industrial plots as significant consumers, it does so in a spatial manner that illustrates how hotspots can result in adjacent areas growing as well. Projections of growth in the Agbogbloshie and Adedenkpo areas are likely as much a result from the number of jobs and households that chose to move there as well as their adjacent location to the South Industrial zones as well as Korle Dudor and Adabraka along Kwame Nkrumah Boulevard. Considering the impact of the industrial sector on the local and regional economy, it is advised for the Volta River Authority and Electricity Company of Ghana to address electricity infrastructure and services from Kwame Nkrumah Circle along Kwame Nkrumah Boulevard to the termination of the Accra-Kumasi Railroad, along its right-of-way towards Obtsey Lamptey Circle and then back to Circle again. Infrastructure improvements along this circuit would serve to greatly benefit not only business and industries but also potentially to a large number of new households which could locate in the area.

Electricity demand in the Sabon Zongo area presents a unique opportunity for introducing a strong sustainability approach to meeting consumption needs. This area could be used as a model for decentralized low voltage electricity supply or incentive based net metering, which includes not only high density residential uses but also institutional land uses such as schools or possibly police stations. A

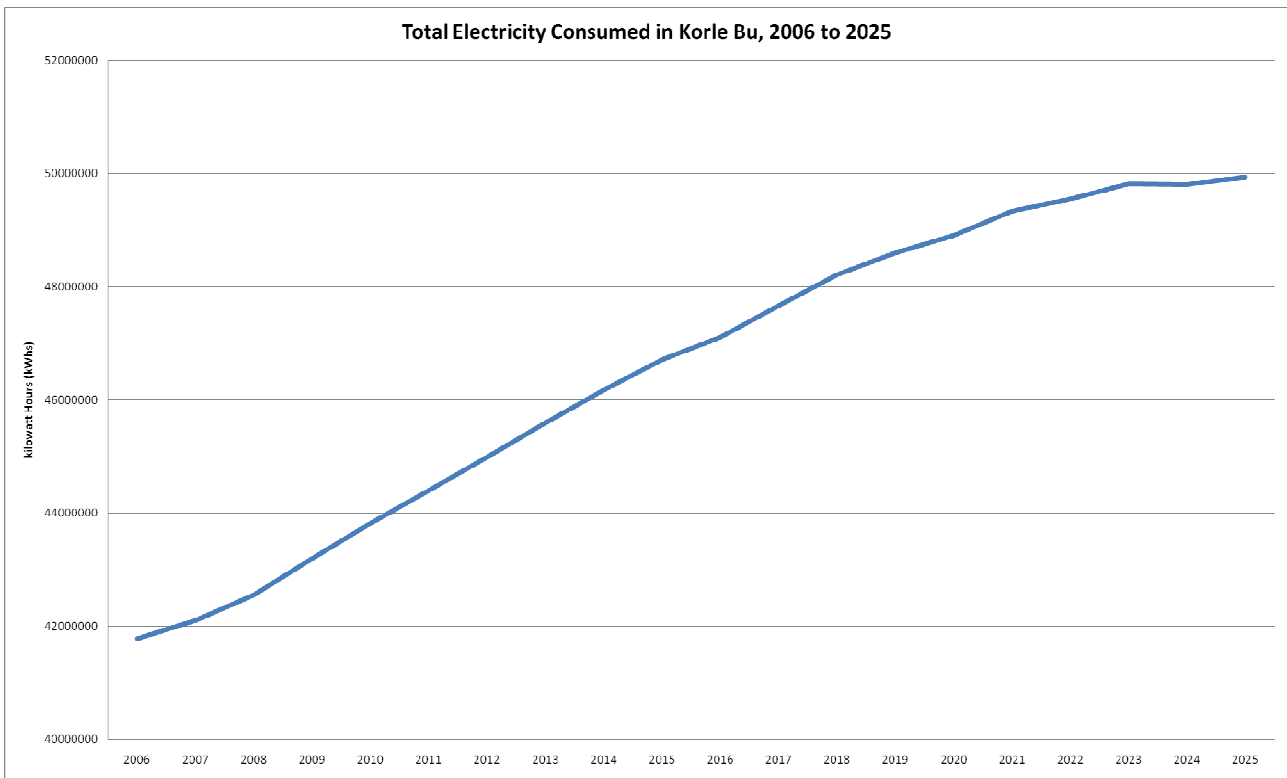

Figure 5.26 Total Projected Electricity Demand in Korle Bu District from 2006 to 2025 based on GAUS-KB urban simulation, demographic and economic growth rates of 2%

second opportunity for introducing a strong sustainability electricity supply plan would be in the area of the Korle Bu Teaching Hospital and the Korle Gonno residential area, which is directly to the south. Korle Gonno is also largely residential, but with densities that are much lower and possibly more manageable than those found in Sabon Zongo.

It should be noted that the demographic and economic projection used in this simulation was very conservative, but still represented an increase of nearly 17% in expected total consumption over the twenty year period. On the contrary increases in average household income of about 5% were modest at best. Furthermore, the plausibility of this model’s projections are remarkable. Sabon Zongo and Adedenkpo are clearly characterized as high density areas where it is questionable how much the residents benefit from their proximity to the central city. The model also clearly indicates the South Industrial Area as a magnet for jobs and electricity consumption, which is also easily validated. Finally, the model projects the importance of the diverse number of businesses located along the western side of Kwame Nkrumah Boulevard, particularly in the direction of Kwame Nkrumah Circle. This avenue along with the railroad right-of-way, appear to be the spine for electricity distribution and consumption in this extremely important district in Ghana’s capital city.



# **Urban Planning, Electricity Demand and the Future of Accra, Ghana**

## Conclusion

Africa is urbanizing at an alarming rate and Urban Planning is a critically missing component of the Development Research agenda. Urban Sprawl is rampant in the cities of West Africa while electricity consumption and CO<sub>2</sub> emissions in developing countries are projected to overtake developed countries between 2015 and 2020. Energy consumption in buildings is the most responsible for CO<sub>2</sub> emissions in both the developed and developing world. Accra, Ghana is an excellent example of an African city which is rapidly urbanizing in a sprawling manner and is a good choice to serve as a case study for developing an urban simulation which projects electricity demand.

Part of the problem with promoting sustainable development for African cities is the complex nature of understanding and describing these urban systems. Multi-agent systems and agent-based models have emerged as useful tools for understanding and simulating complex systems such as a city. One such state of the art framework is the Open Platform for Urban Simulation, which was developed by the Center for Urban Simulation and Policy Studies at the University of Washington and has gained in popularity for use by a number of cities around the world. This research represents the first known example of an agent-based urban simulation system of a major urban city in Africa.

Often real data is not used when modeling cities, because it is not realistic to record all of the attributes needed for large populations, but instead it is useful to generate synthetic populations from surveys which are statistically nearly the same as the real population. When coupled with an entity oriented model, an agent based system can be a powerful tool for understanding and simulating a complex system, such as electricity infrastructure within an urban area. While most electricity models focus on supply side approaches, this research represents the first known example of a large scale disaggregated demand side model of electricity use in either the developed or developing world. Such an approach promotes a diversity of land and energy use controls, incentives and investments which are more focused towards decentralized supply and a better understanding of efficiency measures in the aggregate.

In order to build such a disaggregated model, we have to understand the city in terms of its most basic parts: persons or households and the places where they dwell or work, buildings. Demographic characteristics such as the household profile, income and mobility are necessary when building the basis for an urban simulation system as well as the economic characteristics such as type of employment and location. Assessing and understanding existing land uses as well as infrastructure and social services are also important as well as understanding how much the local government is participating in development or management of urban growth. This is particularly important in Ghana where favoritism is clearly demonstrated in favor of smaller cities in the more rural, northern part of the country.

In order to build an urban simulation system for projecting the disaggregated electricity demand of a city, the Korle Bu district in Accra has been described and modeled in great detail. This description is a building by building estimate aggregated to the plot of approximately 20,000 structures housing 200,000 persons with about 80,000 associated jobs in the central part of Accra, Ghana. This base urban simulation is then used to project the kilowatt-hours consumed by each building within a single simulation year.

The results of the model indicate the South Industrial Park and the extremely dense area of Sabon Zongo are projected to be the two highest areas of electricity consumption during the next 15 years. The area of Agboghloshie and Adedenkpo are also projected to demonstrate significant electricity demand as well as the numerous businesses located along Kwame Nkrumah Boulevard. Overall, electricity demand in Korle Bu is projected to steadily increase from 42,000,000 kilowatt-hours in 2006 to 50,000,000 kilowatt-hours in 2025, a remarkable increase considering average annual income is projected to increase in Korle Bu

from only 1400 to 1500 GHCs per year.

The objective of this work was to create a highly disaggregated property and land use urban simulation system for comprehensively projecting the electricity demand of a large urban area or the Korle Bu district in Accra, Ghana, in terms of either a low, medium, or high population and economic growth rates for the time period 2006 until 2025. In meeting this research objective, the GAUS-KB model annually models household location choice, employment location choice and real estate price. Demographic and economic growth models have been included in order to simulate low, medium and high growth rates. The result is a highly disaggregate urban simulation system which can be used to model electricity demand, and thus fulfills the research objectives intended by this work.

# Appendix

- A. **Technical Addendums**
  - 1. **Output from Simulation Run**
  - 2. **Stata DO file**
- B. **Bibliography**
- C. **Curriculum Vitae**

## Technical Addendum: Selected Years from Simulation Run of GAUS-KB

```

Simulate year 2006: started on Sat Aug 28 02:34:37 2010
  Running Real Estate Price Model (from urbansim.models.real_estate_price_model): started
on Sat Aug 28 02:34:38 2010
    ln_average_value_per_unit=ln(building.average_value_per_unit)....0.0 sec
    Total number of individuals: 19803
    REPM chunk 1 out of 1.: started on Sat Aug 28 02:34:38 2010
      Number of agents in this chunk: 19803
      ln_avg_hh_income = ln(building.aggregate(household.income,
function=mean))....0.0 sec
      ln_emp_30_min = ln_bounded(building.disaggregate
(urbansim_zone.zone.number_of_jobs_within_30_am_lov_time_threshold))
      urbansim_zone.zone.SSS_within_DDD_SSS_threshold
      number_of_jobs = zone.number_of_agents(job)..0.0 sec
      urbansim_zone.zone.SSS_within_DDD_SSS_threshold: completed...0.1 sec
      ln_emp_30_min = ln_bounded(building.disaggregate
(urbansim_zone.zone.number_of_jobs_within_30_am_lov_time_threshold)): completed...0.2 sec
      ln_households = ln(building.number_of_agents(household))....0.0 sec
      ln_job_density_zone = building.disaggregate(zone.number_of_agents(job)/
zone.area)/1000
      zone.number_of_agents(job)/zone.area.....0.0 sec
      ln_job_density_zone = building.disaggregate(zone.number_of_agents(job)/
zone.area)/1000: completed...0.0 sec
      ln_pop_density_zone = building.disaggregate(zone.aggregate(household.persons)/
zone.area)/1000
      zone.aggregate(household.persons)/zone.area
      zone_id = household.disaggregate(building.zone_id)....0.0 sec
      zone.aggregate(household.persons)/zone.area: completed...0.0 sec
      ln_pop_density_zone = building.disaggregate(zone.aggregate(household.persons)/
zone.area)/1000: completed...0.0 sec
      zone_area_bldg = building.disaggregate(zone.area)....0.0 sec
      REPM chunk 1 out of 1.: completed.....0.3 sec
    Running Real Estate Price Model (from urbansim.models.real_estate_price_model):
completed...0.4 sec
  Running Household Transition Model (from urbansim.models.transition_model): started on
Sat Aug 28 02:34:39 2010
    persons      actual target difference      action
    1      15389   15697.0 308.0   +308
    2      7621    7773.0 152.0   +152
    3      7130    7273.0 143.0   +143
    4      7501    7651.0 150.0   +150
    5      6493    6623.0 130.0   +130
    6      4977    5077.0 100.0   +100
    7      2087    2129.0  42.0    +42
    8      916     934.0  18.0    +18
    9      777     793.0  16.0    +16
    10     254     259.0   5.0     +5
    11     47      48.0   1.0     +1
    12     52      53.0   1.0     +1

    Running Household Transition Model (from urbansim.models.transition_model):
completed...0.1 sec
  Running Employment Transition Model (from urbansim.models.transition_model): started on
Sat Aug 28 02:34:39 2010
    sector_id    actual target difference      action
    1      5883    6001   118    +118
    2     12628   12881  253    +253
    3     19532   19923  391    +391
    4     22322   22768  446    +446
    5     19491   19881  390    +390

    Running Employment Transition Model (from urbansim.models.transition_model):
completed...0.1 sec
  Running Household Relocation Model (from urbansim.models.agent_relocation_model):
started on Sat Aug 28 02:34:39 2010
    Number of movers: 54310
  Running Household Relocation Model (from urbansim.models.agent_relocation_model):
completed...0.2 sec
  Running Household Location Choice Model (from
urbansim.models.household_location_choice_model): started on Sat Aug 28 02:34:40 2010
    Total number of individuals: 54310
    HLCM chunk 1 out of 3.: started on Sat Aug 28 02:34:40 2010
    .....      Number of agents in this chunk: 18104
    building.max_households=building.number_of_agents(household)....0.0 sec
    Available capacity: 75604.0 units.
    building.building_id>0.....0.0 sec
    ln_avg_hh_income = ln(building.aggregate(household.income,

```



```

function=mean))....0.0 sec
    ln_emp_30_min = ln_bounded(building.disaggregate
(urbansim_zone.zone.number_of_jobs_within_30_am_lov_time_threshold))
        urbansim_zone.zone.SSS_within_DDD_SSS_threshold
        number_of_jobs = zone.number_of_agents(job)..0.0 sec
        urbansim_zone.zone.SSS_within_DDD_SSS_threshold: completed...0.0 sec
    ln_emp_30_min = ln_bounded(building.disaggregate
(urbansim_zone.zone.number_of_jobs_within_30_am_lov_time_threshold)): completed...0.0 sec
    ln_households = ln(building.number_of_agents(household))....0.0 sec
    ln_job_density_zone = building.disaggregate(zone.number_of_agents(job)/
zone.area)/1000
        zone.number_of_agents(job)/zone.area.....0.0 sec
    ln_job_density_zone = building.disaggregate(zone.number_of_agents(job)/
zone.area)/1000: completed...0.0 sec
    ln_pop_density_zone = building.disaggregate(zone.aggregate(household.persons)/
zone.area)/1000
        zone.aggregate(household.persons)/zone.area
        zone_id = household.disaggregate(building.zone_id)....0.0 sec
        zone.aggregate(household.persons)/zone.area: completed...0.0 sec
    ln_pop_density_zone = building.disaggregate(zone.aggregate(household.persons)/
zone.area)/1000: completed...0.0 sec
    Choice set size: 50
    Number of unplaced agents: 6 (in 3 iterations)
    HLCM chunk 1 out of 3.: completed.....5.0 sec
    HLCM chunk 2 out of 3.: started on Sat Aug 28 02:34:45 2010
    Number of agents in this chunk: 18104
    building.max_households-building.number_of_agents(household)....0.0 sec
    Available capacity: 57506.0 units.
    ln_avg_hh_income = ln(building.aggregate(household.income,
function=mean))....0.0 sec
    ln_households = ln(building.number_of_agents(household))....0.0 sec
    ln_pop_density_zone = building.disaggregate(zone.aggregate(household.persons)/
zone.area)/1000
        zone.aggregate(household.persons)/zone.area
        zone_id = household.disaggregate(building.zone_id)....0.0 sec
        zone.aggregate(household.persons)/zone.area: completed...0.0 sec
    ln_pop_density_zone = building.disaggregate(zone.aggregate(household.persons)/
zone.area)/1000: completed...0.0 sec
    Choice set size: 50
    Number of unplaced agents: 23 (in 3 iterations)
    HLCM chunk 2 out of 3.: completed.....4.3 sec
    HLCM chunk 3 out of 3.: started on Sat Aug 28 02:34:49 2010
    Number of agents in this chunk: 18102
    building.max_households-building.number_of_agents(household)....0.0 sec
    Available capacity: 39425.0 units.
    ln_avg_hh_income = ln(building.aggregate(household.income,
function=mean))....0.0 sec
    ln_households = ln(building.number_of_agents(household))....0.0 sec
    ln_pop_density_zone = building.disaggregate(zone.aggregate(household.persons)/
zone.area)/1000
        zone.aggregate(household.persons)/zone.area
        zone_id = household.disaggregate(building.zone_id)....0.0 sec
        zone.aggregate(household.persons)/zone.area: completed...0.0 sec
    ln_pop_density_zone = building.disaggregate(zone.aggregate
(household.pers.....ons)/zone.area)/1000:
completed...0.0 sec
    Choice set size: 50
    Number of unplaced agents: 407 (in 3 iterations)
    HLCM chunk 3 out of 3.: completed.....4.9 sec
    Running Household Location Choice Model (from
urbansim.models.household_location_choice_model): completed...14.2 sec
    Running Employment Relocation Model (from urbansim.models.agent_relocation_model):
started on Sat Aug 28 02:34:54 2010
    Number of movers: 81454
    Running Employment Relocation Model (from urbansim.models.agent_relocation_model):
completed...0.1 sec
    'agents_grouping_attribute' set to job.home_based_status.
    Running Non_home_based Employment Location Choice Model (from
urbansim.models.employment_location_choice_model): started on Sat Aug 28 02:34:54 2010
    Total number of individuals: 81454
    Non_home_based ELCM chunk 1 out of 2.: started on Sat Aug 28 02:34:54 2010
    Number of agents in this chunk: 40727
    building.max_jobs-building.number_of_agents(job)....0.0 sec
    Available capacity: 98041.0 units.
    ln_employees = ln_bounded(building.number_of_agents(job))....0.0 sec
    ln_pop_density_zone = building.disaggregate(zone.aggregate(household.persons)/
zone.area)/1000
        zone.aggregate(household.persons)/zone.area
        zone_id = household.disaggregate(building.zone_id)....0.0 sec

```

```

zone.aggregate(household.persons)/zone.area: completed...0.0 sec
ln_pop_density_zone = building.disaggregate(zone.aggregate(household.persons)/
zone.area)/1000: completed...0.0 sec
Choice set size: 30
Number of unplaced agents: 0 (in 3 iterations)
Number of unplaced agents: 2 (in 3 iterations)
Number of unplaced agents: 3 (in 3 iterations)
Number of unplaced agents: 13 (in 3 iterations)
Number of unplaced agents: 4 (in 3 iterations)
Non_home_based ELCM chunk 1 out of 2.: completed.....6.5 sec
Non_home_based ELCM chunk 2 out of 2.: started on Sat Aug 28 02:35:01 2010
Number of agents in this chunk: 40727
building.max_jobs=building.number_of_agents(job).....0.0 sec
Available capacity: 57336.0 units.
ln_employees = ln_bounded(building.number_of_agents(job))....0.0 sec
Choice set size: 30
Number of unplaced agents: 20 (in 3 iterations)
Number of unplaced agents: 35 (in 3 iterations)
Number of unplaced agents: 108 (in 3 iterations)
Number of unplaced agents: 137 (in 3 iterations)
Number of unplaced agents: 96 (in 3 iterations)
Non_home_based ELCM chunk 2 out of 2.: completed.....15.4 sec
Running Non_home_based Employment Location Choice Model (from
urbansim.models.employment_location_choice_model): completed...22.0 sec
Writing datasets to cache for year 2006: started on Sat Aug 28 02:35:16 2010
Flushing building
C:\opus\data\accra_zone/runs\run_2.run_2010_08_28_02_34\2006\buildings doesn't
exist and is created
Flushing travel_data
C:\opus\data\accra_zone/runs\run_2.run_2010_08_28_02_34\2006\travel_data doesn't
exist and is created
Flushing home_based_status
C:\opus\data\accra_zone/runs\run_2.run_2010_08_28_02_34\2006\home_based_status
doesn't exist and is created
Flushing zone
C:\opus\data\accra_zone/runs\run_2.run_2010_08_28_02_34\2006\zones doesn't exist
and is created
Flushing household
C:\opus\data\accra_zone/runs\run_2.run_2010_08_28_02_34\2006\households doesn't
exist and is created
Flushing job
C:\opus\data\accra_zone/runs\run_2.run_2010_08_28_02_34\2006\jobs doesn't exist and
is created
Flushing building_type
C:\opus\data\accra_zone/runs\run_2.run_2010_08_28_02_34\2006\building_types doesn't
exist and is created
Writing datasets to cache for year 2006: completed.....0.5 sec
Simulate year 2006: completed.....39.4 sec
....

***** Moving to next year logfile *****

.. Simulate year 2007: started on Sat Aug 28 02:35:18 2010
Running Real Estate Price Model (from urbansim.models.real_estate_price_model): started
on Sat Aug 28 02:35:19 2010
ln_average_value_per_unit=ln(building.average_value_per_unit)....0.0 sec
Total number of individuals: 19803
REPM chunk 1 out of 1.: started on Sat Aug 28 02:35:19 2010
Number of agents in this chunk: 19803
ln_avg_hh_income = ln(building.aggregate(household.income,
function=mean))....0.0 sec
ln_emp_30_min = ln_bounded(building.disaggregate
(urbansim_zone.zone.number_of_jobs_within_30_am_lov_time_threshold))
urbansim_zone.zone.SSS_within_DDD_SSS_threshold
number_of_jobs = zone.number_of_agents(job)..0.0 sec
urbansim_zone.zone.SSS_within_DDD_SSS_threshold: completed...0.1 sec
ln_emp_30_min = ln_bounded(building.disaggregate
(urbansim_zone.zone.number_of_jobs_within_30_am_lov_time_threshold)): completed...0.1 sec
ln_households = ln(building.number_of_agents(household))....0.0 sec
ln_job_density_zone = building.disaggregate(zone.number_of_agents(job)/
zone.area)/1000
zone.number_of_agents(job)/zone.area.....0.0 sec
ln_job_density_zone = building.disaggregate(zone.number_of_agents(job)/
zone.area)/1000: completed...0.0 sec
ln_pop_density_zone = building.disaggregate(zone.aggregate(household.persons)/
zone.area)/1000
zone.aggregate(household.persons)/zone.area

```

```

zone_id = household.disaggregate(building.zone_id)...0.0 sec
zone.aggregate(household.persons)/zone.area: completed...0.0 sec
ln_pop_density_zone = building.disaggregate(zone.aggregate(household.persons)/
zone.area)/1000: completed...0.0 sec
zone_area_bldg = building.disaggregate(zone.area)...0.0 sec
REPM chunk 1 out of 1.: completed.....0.3 sec
Running Real Estate Price Model (from urbansim.models.real_estate_price_model):
completed...0.3 sec
Running Household Transition Model (from urbansim.models.transition_model): started on
Sat Aug 28 02:35:19 2010

```

	persons	actual	target	difference	action
1	15697	16011.0	314.0	+314	
2	7773	7929.0	156.0	+156	
3	7273	7418.0	145.0	+145	
4	7651	7804.0	153.0	+153	
5	6623	6755.0	132.0	+132	
6	5077	5178.0	101.0	+101	
7	2129	2171.0	42.0	+42	
8	934	953.0	19.0	+19	
9	793	808.0	15.0	+15	
10	259	264.0	5.0	+5	
11	48	49.0	1.0	+1	
12	53	54.0	1.0	+1	

```

Running Household Transition Model (from urbansim.models.transition_model):
completed...0.1 sec
Running Employment Transition Model (from urbansim.models.transition_model): started on
Sat Aug 28 02:35:19 2010

```

	sector_id	actual	target	difference	action
1	6001	6121	120	+120	
2	12881	13138	257	+257	
3	19923	20321	398	+398	
4	22768	23224	456	+456	
5	19881	20278	397	+397	

```

Running Employment Transition Model (from urbansim.models.transition_model):
completed...0.1 sec
Running Household Relocation Model (from urbansim.models.agent_relocation_model):
started on Sat Aug 28 02:35:19 2010
Number of movers: 5903

```

```

Running Household Relocation Model (from urbansim.models.agent_relocation_model):
completed...0.2 sec

```

```

Running Household Location Choice Model (from
urbansim.models.household_location_choice_model): started on Sat Aug 28 02:35:19 2010
Total number of individuals: 5903
HLCM chunk 1 out of 3.: started on Sat Aug 28 02:35:19 2010
Number of agents in this chunk: 1968
building.max_households-building.number_of_agents(household)...0.0 sec
Available capacity: 23185.0 units.
building.building_id>0.....0.0 sec
ln_avg_hh_income = ln(building.aggregate(household.income,
function=mean))....0.0 sec
ln_emp_30_min = ln_bounded(building.disaggregate
(urbansim_zone.zone.number_of_jobs_within_30_am_lov_time_threshold))
urbansim_zone.zone.SSS_within_DDD_SSS_threshold
number_of_jobs = zone.number_of_agents(job)..0.0 sec
urbansim_zone.zone.SSS_within_DDD_SSS_threshold: completed...0.0 sec
ln_emp_30_min = ln_bounded(building.disaggregate
(urbansim_zone.zone.number_of_jobs_within_30_am_lov_time_threshold)): completed...0.0 sec
ln_households = ln(building.number_of_agents(household))....0.0 sec
ln_job_density_zone = building.disaggregate(zone.number_of_agents(job)/
zone.area)/1000
zone.number_of_agents(job)/zone.area.....0.0 sec
ln_job_density_zone = building.disaggregate(zone.number_of_agents(job)/
zone.area)/1000: completed...0.0 sec
ln_pop_density_zone = building.disaggregate(zone.aggregate(household.persons)/
zone.area)/1000
zone.aggregate(household.persons)/zone.area
zone_id = household.disaggregate(building.zone_id)...0.0 sec
zone.aggregate(household.persons)/zone.area: completed...0.0 sec
ln_pop_density_zone = building.disaggregate(zone.aggregate(household.persons)/
zone.area)/1000: completed...0.0 sec
Choice set size: 50
Number of unplaced agents: 5 (in 3 iterations)
HLCM chunk 1 out of 3.: completed.....0.5 sec
HLCM chunk 2 out of 3.: started on Sat Aug 28 02:35:20 2010
Number of agents in this chunk: 1968
building.max_households-building.number_of_agents(household)...0.0 sec
Available capacity: 22677.0 units.

```

```

ln_avg_hh_income = ln(building.aggregate(household.income,
function=mean))....0.0 sec
ln_households = ln(building.number_of_agents(household))....0.0 sec
ln_pop_density_zone = building.disaggregate(zone.aggregate(household.persons)/
zone.area)/1000
zone.aggregate(household.persons)/zone.area
zone_id = household.disaggregate(building.zone_id)....0.0 sec
zone.aggregate(household.persons)/zone.area: completed...0.0 sec
ln_pop_density_zone = building.disaggregate(zone.aggregate(household.persons)/
zone.area)/1000: completed...0.0 sec
Choice set size: 50
Number of unplaced agents: 1 (in 3 iterations)
HLCM chunk 2 out of 3.: completed.....0.5 sec
HLCM chunk 3 out of 3.: started on Sat Aug 28 02:35:20 2010
Number of agents in this chunk: 1967
building.max_households-building.number_of_agents(household)....0.0 sec
Available capacity: 22183.0 units.
ln_avg_hh_income = ln(building.aggregate(household.income,
function=mean))....0.0 sec
ln_households = ln(building.number_of_agents(household))....0.0 sec
ln_pop_density_zone = building.disaggregate(zone.aggregate(household.persons)/
zone.area)/1000
zone.aggregate(household.persons)/zone.area
zone_id = household.disaggregate(building.zone_id)....0.0 sec
zone.aggregate(household.persons)/zone.area: completed...0.0 sec
ln_pop_density_zone = building.disaggregate(zone.aggregate(household.persons)/
z.....one.area)/1000: completed...0.0 sec
Choice set size: 50
Number of unplaced agents: 3 (in 3 iterations)
HLCM chunk 3 out of 3.: completed.....0.5 sec
Running Household Location Choice Model (from
urbansim.models.household_location_choice_model): completed...1.5 sec
Running Employment Relocation Model (from urbansim.models.agent_relocation_model):
started on Sat Aug 28 02:35:21 2010
Number of movers: 16593
Running Employment Relocation Model (from urbansim.models.agent_relocation_model):
completed...0.1 sec
'agents_grouping_attribute' set to job.home_based_status.
Running Non_home_based Employment Location Choice Model (from
urbansim.models.employment_location_choice_model): started on Sat Aug 28 02:35:21 2010
Total number of individuals: 16593
Non_home_based ELCM chunk 1 out of 1.: started on Sat Aug 28 02:35:21 2010
Number of agents in this chunk: 16593
building.max_jobs-building.number_of_agents(job)....0.0 sec
Available capacity: 31552.0 units.
ln_employees = ln_bounded(building.number_of_agents(job))....0.0 sec
ln_pop_density_zone = building.disaggregate(zone.aggregate(household.persons)/
zone.area)/1000
zone.aggregate(household.persons)/zone.area
zone_id = household.disaggregate(building.zone_id)....0.0 sec
zone.aggregate(household.persons)/zone.area: completed...0.0 sec
ln_pop_density_zone = building.disaggregate(zone.aggregate(household.persons)/
zone.area)/1000: completed...0.0 sec
Choice set size: 30
Number of unplaced agents: 28 (in 3 iterations)
Number of unplaced agents: 117 (in 3 iterations)
Number of unplaced agents: 339 (in 3 iterations)
Number of unplaced agents: 284 (in 3 iterations)
Number of unplaced agents: 452 (in 3 iterations)
Non_home_based ELCM chunk 1 out of 1.: completed.....8.8 sec
Running Non_home_based Employment Location Choice Model (from
urbansim.models.employment_location_choice_model): completed...8.8 sec
Writing datasets to cache for year 2007: started on Sat Aug 28 02:35:30 2010
Flushing building
C:\opus\data\accra_zone/runs/run_2.run_2010_08_28_02_34\2007\buildings doesn't
exist and is created
Flushing travel_data
C:\opus\data\accra_zone/runs/run_2.run_2010_08_28_02_34\2007\travel_data doesn't
exist and is created
Flushing home_based_status
C:\opus\data\accra_zone/runs/run_2.run_2010_08_28_02_34\2007\home_based_status
doesn't exist and is created
Flushing zone
C:\opus\data\accra_zone/runs/run_2.run_2010_08_28_02_34\2007\zones doesn't exist
and is created
Flushing household
C:\opus\data\accra_zone/runs/run_2.run_2010_08_28_02_34\2007\households doesn't
exist and is created
Flushing job

```

```

C:\opus\data\accra_zone/runs\run_2.run_2010_08_28_02_34\2007\jobs doesn't exist and
is created
Flushing building_type
C:\opus\data\accra_zone/runs\run_2.run_2010_08_28_02_34\2007\building_types doesn't
exist and is created
Writing datasets to cache for year 2007: completed.....0.5 sec
Simulate year 2007: completed.....12.0 sec
..

***** CUT 2008 through 2014 *****

..
Simulate year 2015: started on Sat Aug 28 02:36:57 2010
Running Real Estate Price Model (from urbansim.models.real_estate_price_model): started
on Sat Aug 28 02:36:58 2010
ln_average_value_per_unit=ln(building.average_value_per_unit)....0.0 sec
Total number of individuals: 19803
REPM chunk 1 out of 1.: started on Sat Aug 28 02:36:58 2010
Number of agents in this chunk: 19803
ln_avg_hh_income = ln(building.aggregate(household.income,
function=mean))....0.1 sec
ln_emp_30_min = ln_bounded(building.disaggregate
(urbansim_zone.zone.number_of_jobs_within_30_am_lov_time_threshold)
urbansim_zone.zone.SSS_within_DDD_SSS_threshold
number_of_jobs = zone.number_of_agents(job)..0.1 sec
urbansim_zone.zone.SSS_within_DDD_SSS_threshold: completed...0.2 sec
ln_emp_30_min = ln_bounded(building.disaggregate
(urbansim_zone.zone.number_of_jobs_within_30_am_lov_time_threshold)): completed...0.3 sec
ln_households = ln(building.number_of_agents(household))....0.0 sec
ln_job_density_zone = building.disaggregate(zone.number_of_agents(job)/
zone.area)/1000
zone.number_of_agents(job)/zone.area.....0.1 sec
ln_job_density_zone = building.disaggregate(zone.number_of_agents(job)/
zone.area)/1000: completed...0.1 sec
ln_pop_density_zone = building.disaggregate(zone.aggregate(household.persons)/
zone.area)/1000
zone.aggregate(household.persons)/zone.area
zone_id = household.disaggregate(building.zone_id)....0.0 sec
zone.aggregate(household.persons)/zone.area: completed...0.1 sec
ln_pop_density_zone = building.disaggregate(zone.aggregate(household.persons)/
zone.area)/1000: completed...0.1 sec
zone_area_bldg = building.disaggregate(zone.area)....0.0 sec
REPM chunk 1 out of 1.: completed.....0.7 sec
Running Real Estate Price Model (from urbansim.models.real_estate_price_model):
completed...0.8 sec
Running Household Transition Model (from urbansim.models.transition_model): started on
Sat Aug 28 02:36:58 2010
persons      actual target difference   action
1      18391  18759.0 368.0   +368
2      9108   9290.0 182.0   +182
3      8521   8691.0 170.0   +170
4      8964   9144.0 180.0   +180
5      7760   7915.0 155.0   +155
6      5948   6067.0 119.0   +119
7      2494   2544.0 50.0    +50
8      1095   1117.0 22.0    +22
9      929    947.0  18.0    +18
10     304    310.0  6.0     +6
11     56    57.0   1.0     +1
12     62    63.0   1.0     +1

Running Household Transition Model (from urbansim.models.transition_model):
completed...0.3 sec
Running Employment Transition Model (from urbansim.models.transition_model): started on
Sat Aug 28 02:36:59 2010
sector_id   actual target difference   action
1      7031   7171   140    +140
2     15092 15393  301    +301
3     23343 23809  466    +466
4     26677 27210  533    +533
5     23294 23759  465    +465

Running Employment Transition Model (from urbansim.models.transition_model):
completed...0.2 sec
Running Household Relocation Model (from urbansim.models.agent_relocation_model):
started on Sat Aug 28 02:36:59 2010
Number of movers: 6439
Running Household Relocation Model (from urbansim.models.agent_relocation_model):

```



```

completed...0.2 sec
  Running Household Location Choice Model (from
urbansim.models.household_location_choice_model): started on Sat Aug 28 02:36:59 2010
    Total number of individuals: 6439
    HLCM chunk 1 out of 3.: started on Sat Aug 28 02:36:59 2010
    ..
      Number of agents in this chunk: 2147
      building.max_households-building.number_of_agents(household)...0.1 sec
      Available capacity: 13727.0 units.
      building.building_id>0.....0.0 sec
      ln_avg_hh_income = ln(building.aggregate(household.income,
function=mean))....0.0 sec
      ln_emp_30_min = ln_bounded(building.disaggregate
(urbansim_zone.zone.number_of_jobs_within_30_am_lov_time_threshold))
      urbansim_zone.zone.SSS_within_DDD_SSS_threshold
      number_of_jobs = zone.number_of_agents(job)..0.0 sec
      urbansim_zone.zone.SSS_within_DDD_SSS_threshold: completed...0.0 sec
      ln_emp_30_min = ln_bounded(building.disaggregate
(urbansim_zone.zone.number_of_jobs_within_30_am_lov_time_threshold)): completed...0.0 sec
      ln_households = ln(building.number_of_agents(household))....0.0 sec
      ln_job_density_zone = building.disaggregate(zone.number_of_agents(job)/
zone.area)/1000
      zone.number_of_agents(job)/zone.area.....0.0 sec
      ln_job_density_zone = building.disaggregate(zone.number_of_agents(job)/
zone.area)/1000: completed...0.0 sec
      ln_pop_density_zone = building.disaggregate(zone.aggregate(household.persons)/
zone.area)/1000
      zone.aggregate(household.persons)/zone.area
      zone_id = household.disaggregate(building.zone_id)...0.0 sec
      zone.aggregate(household.persons)/zone.area: completed...0.0 sec
      ln_pop_density_zone = building.disaggregate(zone.aggregate(household.persons)/
zone.area)/1000: completed...0.0 sec
      Choice set size: 50
      Number of unplaced agents: 21 (in 3 iterations)
      HLCM chunk 1 out of 3.: completed.....0.6 sec
      HLCM chunk 2 out of 3.: started on Sat Aug 28 02:37:00 2010
      Number of agents in this chunk: 2147
      building.max_households-building.number_of_agents(household)...0.0 sec
      Available capacity: 13287.0 units.
      ln_avg_hh_income = ln(building.aggregate(household.income,
function=mean))....0.0 sec
      ln_households = ln(building.number_of_agents(household))....0.0 sec
      ln_pop_density_zone = building.disaggregate(zone.aggregate(household.persons)/
zone.area)/1000
      zone.aggregate(household.persons)/zone.area
      zone_id = household.disaggregate(building.zone_id)...0.0 sec
      zone.aggregate(household.persons)/zone.area: completed...0.0 sec
      ln_pop_density_zone = building.disaggregate(zone.aggregate(household.persons)/
zone.area)/1000: completed...0.0 sec
      Choice set size: 50
      Number of unplaced agents: 9 (in 3 iterations)
      HLCM chunk 2 out of 3.: completed.....0.5 sec
      HLCM chunk 3 out of 3.: started on Sat Aug 28 02:37:00 2010
      Number of agents in this chunk: 2145
      building.max_households-building.number_of_agents(household)...0.0 sec
      Available capacity: 12875.0 units.
      ln_avg_hh_income = ln(building.aggregate(household.income,
function=mean))....0.0 sec
      ln_households = ln(building.number_of_agents(household))....0.0 sec
      ln_pop_density_zone = building.disaggregate(zone.aggregate(household.persons)/
zone.area)/1000
      zone.aggregate(household.persons)/zone.area
      zone_id = household.disaggregate(building.zone_id)...0.0 sec
      zone.aggregate(household.persons)/zone.area: completed...0.0 sec
      ln_pop_density_zone = building.disaggregate(zone.aggregate
(household.persons.....)/zone.area)/1000: completed...0.0 sec
      Choice set size: 50
      Number of unplaced agents: 17 (in 3 iterations)
      HLCM chunk 3 out of 3.: completed.....0.5 sec
      Running Household Location Choice Model (from
urbansim.models.household_location_choice_model): completed...1.7 sec
      Running Employment Relocation Model (from urbansim.models.agent_relocation_model):
started on Sat Aug 28 02:37:01 2010
      Number of movers: 19981
      Running Employment Relocation Model (from urbansim.models.agent_relocation_model):
completed...0.1 sec
      'agents_grouping_attribute' set to job.home_based_status.
      Running Non_home_based Employment Location Choice Model (from
urbansim.models.employment_location_choice_model): started on Sat Aug 28 02:37:01 2010
      Total number of individuals: 19981

```

```

Non_home_based ELCM chunk 1 out of 1.: started on Sat Aug 28 02:37:01 2010
  Number of agents in this chunk: 19981
  building.max_jobs=building.number_of_agents(job).....0.1 sec
  Available capacity: 20680.0 units.
  ln_employees = ln_bounded(building.number_of_agents(job))....0.0 sec
  ln_pop_density_zone = building.disaggregate(zone.aggregate(household.persons)/
zone.area)/1000
      zone.aggregate(household.persons)/zone.area
      zone_id = household.disaggregate(building.zone_id)....0.0 sec
      zone.aggregate(household.persons)/zone.area: completed...0.0 sec
  ln_pop_density_zone = building.disaggregate(zone.aggregate(household.persons)/
zone.area)/1000: completed...0.0 sec
  Choice set size: 30
  Number of unplaced agents: 10 (in 3 iterations)
  Number of unplaced agents: 58 (in 3 iterations)
  Number of unplaced agents: 435 (in 3 iterations)
  Number of unplaced agents: 266 (in 3 iterations)
  Number of unplaced agents: 865 (in 3 iterations)
  Non_home_based ELCM chunk 1 out of 1.: completed.....6.2 sec
Running Non_home_based Employment Location Choice Model (from
urbansim.models.employment_location_choice_model): completed...6.3 sec
Writing datasets to cache for year 2015: started on Sat Aug 28 02:37:07 2010
  Flushing building
  C:\opus\data\accra_zone/runs\run_2.run_2010_08_28_02_34\2015\buildings doesn't
exist and is created
  Flushing travel_data
  C:\opus\data\accra_zone/runs\run_2.run_2010_08_28_02_34\2015\travel_data doesn't
exist and is created
  Flushing home_based_status
  C:\opus\data\accra_zone/runs\run_2.run_2010_08_28_02_34\2015\home_based_status
doesn't exist and is created
  Flushing zone
  C:\opus\data\accra_zone/runs\run_2.run_2010_08_28_02_34\2015\zones doesn't exist
and is created
  Flushing household
  C:\opus\data\accra_zone/runs\run_2.run_2010_08_28_02_34\2015\households doesn't
exist and is created
  Flushing job
  C:\opus\data\accra_zone/runs\run_2.run_2010_08_28_02_34\2015\jobs doesn't exist and
is created
  Flushing building_type
  C:\opus\data\accra_zone/runs\run_2.run_2010_08_28_02_34\2015\building_types doesn't
exist and is created
  Writing datasets to cache for year 2015: completed.....0.8 sec
  Simulate year 2015: completed.....10.8 sec
....

***** CUT 2016 through 2019 *****

....
  Simulate year 2020: started on Sat Aug 28 02:38:05 2010
  Running Real Estate Price Model (from urbansim.models.real_estate_price_model): started
on Sat Aug 28 02:38:05 2010
  ln_average_value_per_unit=ln(building.average_value_per_unit)....0.1 sec
  Total number of individuals: 19803
  REPM chunk 1 out of 1.: started on Sat Aug 28 02:38:05 2010
  Number of agents in this chunk: 19803
  ln_avg_hh_income = ln(building.aggregate(household.income,
function=mean))....0.2 sec
  ln_emp_30_min = ln_bounded(building.disaggregate
(urbansim_zone.zone.number_of_jobs_within_30_am_lov_time_threshold))
      urbansim_zone.zone.SSS_within_DDD_SSS_threshold
      number_of_jobs = zone.number_of_agents(job)..0.1 sec
      urbansim_zone.zone.SSS_within_DDD_SSS_threshold: completed...0.3 sec
  ln_emp_30_min = ln_bounded(building.disaggregate
(urbansim_zone.zone.number_of_jobs_within_30_am_lov_time_threshold)): completed...0.4 sec
  ln_households = ln(building.number_of_agents(household))....0.0 sec
  ln_job_density_zone = building.disaggregate(zone.number_of_agents(job)/
zone.area)/1000
      zone.number_of_agents(job)/zone.area.....0.1 sec
  ln_job_density_zone = building.disaggregate(zone.number_of_agents(job)/
zone.area)/1000: completed...0.1 sec
  ln_pop_density_zone = building.disaggregate(zone.aggregate(household.persons)/
zone.area)/1000
      zone.aggregate(household.persons)/zone.area
      zone_id = household.disaggregate(building.zone_id)....0.0 sec
      zone.aggregate(household.persons)/zone.area: completed...0.1 sec
  ln_pop_density_zone = building.disaggregate(zone.aggregate(household.persons)/

```

```

zone.area)/1000: completed...0.1 sec
    zone_area_bldg = building.disaggregate(zone.area)...0.0 sec
    REPM chunk 1 out of 1.: completed.....0.9 sec
    Running Real Estate Price Model (from urbansim.models.real_estate_price_model):
completed...1.0 sec
    Running Household Transition Model (from urbansim.models.transition_model): started on
Sat Aug 28 02:38:06 2010
    persons      actual target difference    action
    1      20305   20712.0 407.0    +407
    2      10056   10257.0 201.0    +201
    3       9408   9596.0 188.0    +188
    4       9897   10095.0 198.0    +198
    5       8567   8739.0 172.0    +172
    6       6567   6698.0 131.0    +131
    7       2754   2809.0 55.0     +55
    8       1209   1233.0 24.0     +24
    9       1025   1046.0 21.0     +21
    10      335     342.0 7.0      +7
    11      62      63.0 1.0      +1
    12      69      70.0 1.0      +1

    Running Household Transition Model (from urbansim.models.transition_model):
completed...0.4 sec
    Running Employment Transition Model (from urbansim.models.transition_model): started on
Sat Aug 28 02:38:07 2010
    sector_id    actual target difference    action
    1       7762    7918 156     +156
    2      16662   16996 334     +334
    3      25772   26288 516     +516
    4      29453   30042 589     +589
    5      25718   26232 514     +514

    Running Employment Transition Model (from urbansim.models.transition_model):
completed...0.3 sec
    Running Household Relocation Model (from urbansim.models.agent_relocation_model):
started on Sat Aug 28 02:38:07 2010
    Number of movers: 7521
    Running Household Relocation Model (from urbansim.models.agent_relocation_model):
completed...0.2 sec
    Running Household Location Choice Model (from
urbansim.models.household_location_choice_model): started on Sat Aug 28 02:38:07 2010
    Total number of individuals: 7521
    HLCM chunk 1 out of 3.: started on Sat Aug 28 02:38:07 2010
    ..      Number of agents in this chunk: 2507
            building.max_households-building.number_of_agents(household)...0.1 sec
            Available capacity: 7583.0 units.
            building.building_id>0.....0.0 sec
            ln_avg_hh_income = ln(building.aggregate(household.income,
function=mean))....0.0 sec
            ln_emp_30_min = ln_bounded(building.disaggregate
(urbansim_zone.zone.number_of_jobs_within_30_am_lov_time_threshold))
            urbansim_zone.zone.SSS_within_DDD_SSS_threshold
            number_of_jobs = zone.number_of_agents(job)..0.0 sec
            urbansim_zone.zone.SSS_within_DDD_SSS_threshold: completed...0.0 sec
            ln_emp_30_min = ln_bounded(building.disaggregate
(urbansim_zone.zone.number_of_jobs_within_30_am_lov_time_threshold)): completed...0.0 sec
            ln_households = ln(building.number_of_agents(household))....0.0 sec
            ln_job_density_zone = building.disaggregate(zone.number_of_agents(job)/
zone.area)/1000
            zone.number_of_agents(job)/zone.area.....0.0 sec
            ln_job_density_zone = building.disaggregate(zone.number_of_agents(job)/
zone.area)/1000: completed...0.0 sec
            ln_pop_density_zone = building.disaggregate(zone.aggregate(household.persons)/
zone.area)/1000
            zone.aggregate(household.persons)/zone.area
            zone_id = household.disaggregate(building.zone_id)...0.0 sec
            zone.aggregate(household.persons)/zone.area: completed...0.0 sec
            ln_pop_density_zone = building.disaggregate(zone.aggregate(household.persons)/
zone.area)/1000: completed...0.0 sec
            Choice set size: 50
            Number of unplaced agents: 118 (in 3 iterations)
            HLCM chunk 1 out of 3.: completed.....0.7 sec
            HLCM chunk 2 out of 3.: started on Sat Aug 28 02:38:08 2010
            Number of agents in this chunk: 2507
            building.max_households-building.number_of_agents(household)...0.0 sec
            Available capacity: 7131.0 units.
            ln_avg_hh_income = ln(building.aggregate(household.income,
function=mean))....0.0 sec
            ln_households = ln(building.number_of_agents(household))....0.0 sec

```

```

zone.area)/1000      ln_pop_density_zone = building.disaggregate(zone.aggregate(household.persons)/
zone.aggregate(household.persons)/zone.area
                    zone_id = household.disaggregate(building.zone_id)...0.0 sec
                    zone.aggregate(household.persons)/zone.area: completed...0.0 sec
ln_pop_density_zone = building.disaggregate(zone.aggregate(household.persons)/
zone.area)/1000: completed...0.0 sec
Choice set size: 50
Number of unplaced agents: 162 (in 3 iterations)
HLCM chunk 2 out of 3.: completed.....0.6 sec
HLCM chunk 3 out of 3.: started on Sat Aug 28 02:38:09 2010
Number of agents in this chunk: 2507
building.max_households-building.number_of_agents(household)...0.0 sec
Available capacity: 6731.0 units.
ln_avg_hh_income = ln(building.aggregate(household.income,
function=mean))....0.0 sec
ln_households = ln(building.number_of_agents(household))....0.0 sec
ln_pop_density_zone = building.disaggregate(zone.aggregate(household.persons)/
zone.area)/1000
                    zone.aggregate(household.persons)/zone.area
                    zone_id = household.disaggregate(building.zone_id)...0.0 sec
                    zone.aggregate(household.persons)/zone.area: completed...0.0 sec
ln_pop_density_zone = building.disaggregate(zone.aggregate
(household.pe.....rsons)/zone.area)/1000: completed...0.0 sec
Choice set size: 50
Number of unplaced agents: 195 (in 3 iterations)
HLCM chunk 3 out of 3.: completed.....0.7 sec
Running Household Location Choice Model (from
urbansim.models.household_location_choice_model): completed...2.0 sec
Running Employment Relocation Model (from urbansim.models.agent_relocation_model):
started on Sat Aug 28 02:38:09 2010
Number of movers: 23394
Running Employment Relocation Model (from urbansim.models.agent_relocation_model):
completed...0.1 sec
'agents_grouping_attribute' set to job.home_based_status.
Running Non_home_based Employment Location Choice Model (from
urbansim.models.employment_location_choice_model): started on Sat Aug 28 02:38:09 2010
Total number of individuals: 23394
Non_home_based ELCM chunk 1 out of 1.: started on Sat Aug 28 02:38:09 2010
Number of agents in this chunk: 23394
building.max_jobs-building.number_of_agents(job)....0.1 sec
Available capacity: 13959.0 units.
ln_employees = ln_bounded(building.number_of_agents(job))....0.0 sec
ln_pop_density_zone = building.disaggregate(zone.aggregate(household.persons)/
zone.area)/1000
                    zone.aggregate(household.persons)/zone.area
                    zone_id = household.disaggregate(building.zone_id)...0.0 sec
                    zone.aggregate(household.persons)/zone.area: completed...0.0 sec
ln_pop_density_zone = building.disaggregate(zone.aggregate(household.persons)/
zone.area)/1000: completed...0.0 sec
Choice set size: 30
Number of unplaced agents: 19 (in 3 iterations)
Number of unplaced agents: 115 (in 3 iterations)
Number of unplaced agents: 1020 (in 3 iterations)
Number of unplaced agents: 697 (in 3 iterations)
Number of unplaced agents: 1981 (in 3 iterations)
Non_home_based ELCM chunk 1 out of 1.: completed.....7.8 sec
Running Non_home_based Employment Location Choice Model (from
urbansim.models.employment_location_choice_model): completed...7.9 sec
Writing datasets to cache for year 2020: started on Sat Aug 28 02:38:17 2010
Flushing building
C:\opus\data\accra_zone/runs/run_2.run_2010_08_28_02_34\2020\buildings doesn't
exist and is created
Flushing travel_data
C:\opus\data\accra_zone/runs/run_2.run_2010_08_28_02_34\2020\travel_data doesn't
exist and is created
Flushing home_based_status
C:\opus\data\accra_zone/runs/run_2.run_2010_08_28_02_34\2020\home_based_status
doesn't exist and is created
Flushing zone
C:\opus\data\accra_zone/runs/run_2.run_2010_08_28_02_34\2020\zones doesn't exist
and is created
Flushing household
C:\opus\data\accra_zone/runs/run_2.run_2010_08_28_02_34\2020\households doesn't
exist and is created
Flushing job
C:\opus\data\accra_zone/runs/run_2.run_2010_08_28_02_34\2020\jobs doesn't exist and
is created
Flushing building_type

```

C:\opus\data\accra\_zone/runs/run\_2.run\_2010\_08\_28\_02\_34\2020\building\_types doesn't exist and is created

Writing datasets to cache for year 2020: completed.....1.0 sec  
Simulate year 2020: completed.....13.5 sec

..

\*\*\*\*\* CUT 2021 through 2024 \*\*\*\*\*

..... Simulate year 2025: started on Sat Aug 28 02:39:28 2010  
Running Real Estate Price Model (from urbansim.models.real\_estate\_price\_model): started on Sat Aug 28 02:39:28 2010

ln\_average\_value\_per\_unit=ln(building.average\_value\_per\_unit)....0.1 sec  
Total number of individuals: 19803  
REPM chunk 1 out of 1.: started on Sat Aug 28 02:39:28 2010  
Number of agents in this chunk: 19803  
ln\_avg\_hh\_income = ln(building.aggregate(household.income, function=mean))....0.2 sec  
ln\_emp\_30\_min = ln\_bounded(building.disaggregate(urbansim\_zone.zone.number\_of\_jobs\_within\_30\_am\_lov\_time\_threshold))  
urbansim\_zone.zone.SSS\_within\_DDD\_SSS\_threshold  
number\_of\_jobs = zone.number\_of\_agents(job)..0.2 sec  
urbansim\_zone.zone.SSS\_within\_DDD\_SSS\_threshold: completed...0.4 sec  
ln\_emp\_30\_min = ln\_bounded(building.disaggregate(urbansim\_zone.zone.number\_of\_jobs\_within\_30\_am\_lov\_time\_threshold)): completed...0.5 sec  
ln\_households = ln(building.number\_of\_agents(household))....0.0 sec  
ln\_job\_density\_zone = building.disaggregate(zone.number\_of\_agents(job)/zone.area)/1000  
zone.number\_of\_agents(job)/zone.area.....0.1 sec  
ln\_job\_density\_zone = building.disaggregate(zone.number\_of\_agents(job)/zone.area)/1000: completed...0.1 sec  
ln\_pop\_density\_zone = building.disaggregate(zone.aggregate(household.persons)/zone.area)/1000  
zone.aggregate(household.persons)/zone.area  
zone\_id = household.disaggregate(building.zone\_id)....0.0 sec  
zone.aggregate(household.persons)/zone.area: completed...0.1 sec  
ln\_pop\_density\_zone = building.disaggregate(zone.aggregate(household.persons)/zone.area)/1000: completed...0.1 sec  
zone\_area\_bldg = building.disaggregate(zone.area)....0.0 sec  
REPM chunk 1 out of 1.: completed.....1.0 sec  
Running Real Estate Price Model (from urbansim.models.real\_estate\_price\_model): completed...1.2 sec

Running Household Transition Model (from urbansim.models.transition\_model): started on Sat Aug 28 02:39:30 2010

persons	actual	target	difference	action
1	22419	22867.0	448.0	+448
2	11102	11324.0	222.0	+222
3	10387	10595.0	208.0	+208
4	10928	11146.0	218.0	+218
5	9459	9648.0	189.0	+189
6	7251	7396.0	145.0	+145
7	3040	3101.0	61.0	+61
8	1334	1361.0	27.0	+27
9	1132	1155.0	23.0	+23
10	370	377.0	7.0	+7
11	68	70.0	2.0	+2
12	76	77.0	1.0	+1

Running Household Transition Model (from urbansim.models.transition\_model): completed...0.5 sec

Running Employment Transition Model (from urbansim.models.transition\_model): started on Sat Aug 28 02:39:30 2010

sector_id	actual	target	difference	action
1	8570	8742	172	+172
2	18397	18765	368	+368
3	28454	29024	570	+570
4	32519	33169	650	+650
5	28395	28963	568	+568

Running Employment Transition Model (from urbansim.models.transition\_model): completed...0.3 sec

Running Household Relocation Model (from urbansim.models.agent\_relocation\_model): started on Sat Aug 28 02:39:30 2010

Number of movers: 10753

Running Household Relocation Model (from urbansim.models.agent\_relocation\_model): completed...0.2 sec

Running Household Location Choice Model (from urbansim.models.household\_location\_choice\_model): started on Sat Aug 28 02:39:31 2010



```

Total number of individuals: 10753
HLCM chunk 1 out of 3.: started on Sat Aug 28 02:39:31 2010
..
    Number of agents in this chunk: 3585
    building.max_households-building.number_of_agents(household)...0.1 sec
    Available capacity: 3163.0 units.
    building.building_id>0.....0.0 sec
    ln_avg_hh_income = ln(building.aggregate(household.income,
function=mean))....0.0 sec
    ln_emp_30_min = ln_bounded(building.disaggregate
(urbansim_zone.zone.number_of_jobs_within_30_am_lov_time_threshold))
    urbansim_zone.zone.SSS_within_DDD_SSS_threshold
    number_of_jobs = zone.number_of_agents(job)..0.0 sec
    urbansim_zone.zone.SSS_within_DDD_SSS_threshold: completed...0.0 sec
    ln_emp_30_min = ln_bounded(building.disaggregate
(urbansim_zone.zone.number_of_jobs_within_30_am_lov_time_threshold)): completed...0.0 sec
    ln_households = ln(building.number_of_agents(household))....0.0 sec
    ln_job_density_zone = building.disaggregate(zone.number_of_agents(job)/
zone.area)/1000
    zone.number_of_agents(job)/zone.area.....0.0 sec
    ln_job_density_zone = building.disaggregate(zone.number_of_agents(job)/
zone.area)/1000: completed...0.0 sec
    ln_pop_density_zone = building.disaggregate(zone.aggregate(household.persons)/
zone.area)/1000
    zone.aggregate(household.persons)/zone.area
    zone_id = household.disaggregate(building.zone_id)...0.0 sec
    zone.aggregate(household.persons)/zone.area: completed...0.0 sec
    ln_pop_density_zone = building.disaggregate(zone.aggregate(household.persons)/
zone.area)/1000: completed...0.0 sec
    Choice set size: 50
    Number of unplaced agents: 1358 (in 3 iterations)
    HLCM chunk 1 out of 3.: completed.....1.0 sec
    HLCM chunk 2 out of 3.: started on Sat Aug 28 02:39:32 2010
    Number of agents in this chunk: 3585
    building.max_households-building.number_of_agents(household)...0.0 sec
    Available capacity: 2936.0 units.
    ln_avg_hh_income = ln(building.aggregate(household.income,
function=mean))....0.0 sec
    ln_households = ln(building.number_of_agents(household))....0.0 sec
    ln_pop_density_zone = building.disaggregate(zone.aggregate(household.persons)/
zone.area)/1000
    zone.aggregate(household.persons)/zone.area
    zone_id = household.disaggregate(building.zone_id)...0.0 sec
    zone.aggregate(household.persons)/zone.area: completed...0.0 sec
    ln_pop_density_zone = building.disaggregate(zone.aggregate(household.persons)/
zone.area)/1000: completed...0.0 sec
    Choice set size: 50
    Number of unplaced agents: 1411 (in 3 iterations)
    HLCM chunk 2 out of 3.: completed.....1.0 sec
    HLCM chunk 3 out of 3.: started on Sat Aug 28 02:39:33 2010
    Number of agents in this chunk: 3583
    building.max_households-building.number_of_agents(household)...0.0 sec
    Available capacity: 2839.0 units.
    ln_avg_hh_income = ln(building.aggregate(household.income,
function=mean))....0.0 sec
    ln_households = ln(building.number_of_agents(household))....0.0 sec
    ln_pop_density_zone = building.disaggregate(zone.aggregate(household.persons)/
zone.area)/1000
    zone.aggregate(household.persons)/zone.area
    zone_id = household.disaggregate(building.zone_id)...0.0 sec
    zone.aggregate(household.persons)/zone.area: completed...0.0 sec
    ln_pop_density_zone = building.disaggregate(zone.aggregate
(household.persons)/zone.area)/1000: completed...0.0 sec
    Choice set size: 50
    Number of unplaced agents: 1392 (in 3 iterations)
    HLCM chunk 3 out of 3.: completed.....1.0 sec
    Running Household Location Choice Model (from
urbansim.models.household_location_choice_model): completed...3.0 sec
    Running Employment Relocation Model (from urbansim.models.agent_relocation_model):
started on Sat Aug 28 02:39:34 2010
    Number of movers: 28747
    Running Employment Relocation Model (from urbansim.models.agent_relocation_model):
completed...0.1 sec
    'agents_grouping_attribute' set to job.home_based_status.
    Running Non_home_based Employment Location Choice Model (from
urbansim.models.employment_location_choice_model): started on Sat Aug 28 02:39:34 2010
    Total number of individuals: 28747
    Non_home_based ELCM chunk 1 out of 1.: started on Sat Aug 28 02:39:34 2010
    Number of agents in this chunk: 28747
    building.max_jobs-building.number_of_agents(job)....0.1 sec

```

```

Available capacity: 8125.0 units.
ln_employees = ln_bounded(building.number_of_agents(job))....0.0 sec
ln_pop_density_zone = building.disaggregate(zone.aggregate(household.persons)/
zone.area)/1000
    zone.aggregate(household.persons)/zone.area
    zone_id = household.disaggregate(building.zone_id)....0.0 sec
    zone.aggregate(household.persons)/zone.area: completed...0.0 sec
    ln_pop_density_zone = building.disaggregate(zone.aggregate(household.persons)/
zone.area)/1000: completed...0.0 sec
    Choice set size: 30
    Number of unplaced agents: 41 (in 3 iterations)
    Number of unplaced agents: 186 (in 3 iterations)
    Number of unplaced agents: 2186 (in 3 iterations)
    Number of unplaced agents: 1428 (in 3 iterations)
    Number of unplaced agents: 4108 (in 3 iterations)
    Non_home_based ELCM chunk 1 out of 1.: completed.....10.0 sec
    Running Non_home_based Employment Location Choice Model (from
urbansim.models.employment_location_choice_model): completed...10.1 sec
    Writing datasets to cache for year 2025: started on Sat Aug 28 02:39:44 2010
    Flushing building
    C:\opus\data\accra_zone/runs/run_2.run_2010_08_28_02_34\2025\buildings doesn't
exist and is created
    Flushing travel_data
    C:\opus\data\accra_zone/runs/run_2.run_2010_08_28_02_34\2025\travel_data doesn't
exist and is created
    Flushing home_based_status
    C:\opus\data\accra_zone/runs/run_2.run_2010_08_28_02_34\2025\home_based_status
doesn't exist and is created
    Flushing zone
    C:\opus\data\accra_zone/runs/run_2.run_2010_08_28_02_34\2025\zones doesn't exist
and is created
    Flushing household
    C:\opus\data\accra_zone/runs/run_2.run_2010_08_28_02_34\2025\households doesn't
exist and is created
    Flushing job
    C:\opus\data\accra_zone/runs/run_2.run_2010_08_28_02_34\2025\jobs doesn't exist and
is created
    Flushing building_type
    C:\opus\data\accra_zone/runs/run_2.run_2010_08_28_02_34\2025\building_types doesn't
exist and is created
    Writing datasets to cache for year 2025: completed.....1.3 sec
    Simulate year 2025: completed.....17.4 sec
..

```

## Technical Addendum: Bootstrap Estimation DO file in Stata used to Generate Synthetic Populations from the Ghana Living Standard Survey (2005)

```
Clear
cd "C:\Documents and Settings\ZEF\Desktop\"
local dsn="simulate.dta"
use "`dsn'",clear
sum
pweight *
local nn=1000
forvalues i = 1/`nn' {
    use "`dsn'"
    bsample
    dis "b`i'.dta"
    save "b`i'.dta",replace
        count
}
use "`dsn'",clear

forvalues i = 1/`nn' {
    append using "b`i'.dta"
        count
}

di "***** Finished"
forvalues i = 1/`nn' {
    erase "b`i'.dta"
}
save simulationfull,replace

sum
pweight *

misschk,gen(_m)
drop if _mnumber>0

bsample 200000

sum
pweight *
save korlebu200000,replace
```

## REFERENCES

- Akinlo, A.E. (2008). Energy consumption and economic growth: Evidence from 11 Sub-Sahara African countries. *Energy Economics* 30, 2391–2400.
- Angel, Shlomo , Sheppard, Stephen C. , and Civco Daniel L., Buckley, Robert , Chabaeva, Anna , Gitlin, Lucy , Kraley, Alison , Parent, Jason , and Perlin, Micah. (2005). The Dynamics of Global Urban Expansion. Transport and Urban Development Department, The World Bank, Washington D.C.
- Avato, Patrick, Coony, Jonathan (2008). Accelerating Clean Energy Technology Research, Development, and Deployment: Lessons from Non-energy Sectors. World Bank Working Paper No. 138. The World Bank, Washington, D.C.
- Ayers, Jesse (2009). UrbanSim\OPUS Real Estate Development Model. Maricopa Association of Governments. Phoenix, Arizona, USA.
- Baker, Judy L. (2008). Urban Poverty: A Global View. The International Bank for Reconstruction and Development, The World Bank. Washington, DC.
- Bertrand, Monique, Delaunay, Daniel (2005). Residential Mobility in the Greater Accra Region: Individual and Geographical Differentiations. Institut de Recherche pour le Developpement (IRD). Paris.
- Bhattacharyya, Subhes C., Timilsina, Govinda R. (2009). Energy Demand Models for Policy Formulation: A Comparative Study of Energy Demand Models. Policy Research Working Paper 4866, Development Research Group: Environment and Energy Team. The World Bank.
- Buckley, Robert M., Mathema, Ashna S. (2007). Is Accra a Superstar City? Policy Research Working Paper 4453, Finance Economics and Urban Department, Urban Division. Washington, DC.
- Buckley, Robert M., Mathema, Ashna S. (2007). Real Estate and Remittances in Accra, Ghana: A Case of the Winner's Curse? Public-Private Infrastructure Advisory Facility, Multilateral Investment Guarantee Agency.
- Buckley, Robert M., Mathema, Ashna S. (2008). Real Estate Regulations in Accra: Some Macroeconomic Consequences? *Urban Studies*; 45; 2249
- Center for Environment, Health Research and Training (2007). Environment and Social Management Framework. Ministry of Transportation, Transport Sector Development Program, Road Sector. Tema, Ghana.
- Center for Urban Simulation and Policy Analysis (2009). The Open Platform for Urban Simulation: Users Guide and Reference Manual. University of Washington, Seattle, Washington, USA.
- Chen, Sheng-Tung, Kuo, Hsiao-I, Chen, Chi-Chung (2007). The relationship between GDP and electricity consumption in 10 Asian countries. *Energy Policy* 35 2611–2621.
- Chien-Chiang Lee (2005). Energy consumption and GDP in developing countries: A cointegrated panel analysis. *Energy Economics* 27, 415– 427.

Coulombe, Harold, Wodon, Quentin (2007). Poverty, Livelihoods, and Access to Basic Services in Ghana. Ghana CEM: Meeting the Challenge of Accelerated and Shared Growth. The World Bank. Washington, DC.

Cox, Nicholas (2002). Speaking Stata: How to Move Step by: Step. The Stata Journal 2, Number 1, pp. 86-102.

Crooks, Andrew, Castle, Christian, and Batty, Michael (2007). Key Challenges in Agent-Based Modelling for Geo-Spatial Simulation. Working Paper 121. Centre for Advanced Spatial Analysis (CASA), University College London. London.

Czernohous, C., Fichtner, W., Veit, D., & Weinhardt, C. (2003). Management decision support using long-term market simulation. *Information Systems and e-Business Management*, 1(4), 405-423.

Dauda, Honourable Collins (2009). Improving Land Administration in Ghana: Lessons and Challenges in Moving Ahead, Presentation. Conference on Land Governance in Support of MDGs: Responding to New Challenges. Washington, DC.

Energy Commission of Ghana. (2003). Solar Wind Report: Republic of Ghana.

Energy Commission of Ghana (2003). Strategic National Energy Plan: 2005 - 2020, Strategic National Energy Plan - 2005-2020, Indigenous Energy Resource Catalogue. Kwame Nkrumah University of Science and Technology. Kumasi, Ghana

Energy Commission of Ghana (2006). Strategic National Energy Plan: 2006 - 2020: Annex I, Energy Supply to the Economy, Electricity. Republic of Ghana.

Energy Foundation (2008). Licensing Framework for Distributed Power Generation. Accra, Ghana.

Energy Foundation (2008). Saving Electrical Energy in the Residential Sector: Combining Education and Technology. Good Practice Case Study 005. Cantonments, Accra, Ghana.

Energy Foundation (2008). Saving Energy in Public Buildings: Electrical Energy Savings in a Government Ministry Building (Minsitry of Mines & Energy). Good Practice Case Study 001. Cantonments, Accra, Ghana.

Energy Sector Management Assistance Program, Program Description (2009). ESMAP's Energy Efficient Cities Initiative, The World Bank.

Energy Sector Management Assistance Program (2007). Scaling Up Demand-Side Energy Efficiency Improvements through Programmatic CDM. ESMAP Technical Paper 120/07, Carbon Finance Unit World Bank, Washington, DC.

Energy Sector Management Assistance Program (2006). Scaling Sub-Saharan Africa: Introducing Low-cost Methods in Electricity Distribution Networks. ESMAP Technical Paper 104/06, Energy and Water Department, Washington, DC.

Faah, George (2008). Road Transportation Impact on Ghana's Future Energy and Environment. Faculty of



Economics and Business Administration, Technische Universität Freiberg. Freiberg, Germany.

Farvacque-Vitkovic, Catherine, Godin, Lucien, LeRoux, Hughes, Verdet, Florence and Chavez, Roberto (2005). *Street Addressing and the Management of Cities*. Directions in Development. The World Bank, Washington, DC.

Farvacque-Vitkovic, Catherine, Raghunath, Madhu, Eghoff, Christian, Boakye, Charles (2008). *Development of the Cities of Ghana: Challenges, Priorities and Tools*. Africa Region Working Paper Series Number 110, Washington, D.C.

Federal Ministry of Education and Research (2008). *Energy and Climate Efficient Structures in Urban Growth Centres: Guiding Principles for Targeting the Federal Ministry of Education and Research's Funding Priority on the Sustainable Development of the Megacities of Tomorrow*. Germany.

Feitosa, Flávia F., Le, Quang Bao, and Vlek, Paul L.G. (2009). *Multi-Agent Simulator for Urban Segregation (MASUS): A Tool to Explore Alternatives for Promoting Inclusive Cities*. Center for Development Research (ZEF), University of Bonn. Bonn, Germany.

Frick, Martin, Axhausen, Kay W. (2004). *Generating Synthetic Populations using IPF and Monte Carlo Techniques: Some New Results*. Conference paper STRC 2004, Swiss Transport Research Conference. Zurich.

Genoese, M., Sensfuß, F., Weidlich, A., Most, D., & Rentz, O. (2005). *Development of an agentbased model to analyse the effect of renewable energy on electricity markets*: University of Karlsruhe.

German National Committee on Global Change Research (2008). *Global Change Research in Germany 2008*. Federal Ministry of Education and Research. Munich, Germany.

Ghana Statistical Service. (2003). *Core Welfare Indicators Questionnaire (CWIQ) Survey: National Summary: Republic of Ghana*. Accra, Ghana.

Ghana Statistical Service. (2008). *Ghana Living Standard Survey: Report of the Fifth Round (GLSS 5)*. Accra, Ghana.

Grant, Richard (2009). *Globalizing City: The Urban and Economic Transformation of Accra, Ghana*. Syracuse University Press, Syracuse, New York, USA.

Hughes, Thomas P. (1993). *Networks of Power: Electrification in Western Society, 1880—1930*. The John Hopkins University Press, Baltimore and London.

International Bank for Reconstruction and Development, International Development Association (2009). *Management Report and Recommendation in Response to the Inspection Panel Investigation Report. Ghana: Second Urban Environmental Sanitation Project, IDA Credit No. 3889-GH*.

Jin, Ying, Williams, Ian, Shahkarami, Mo (2002). *A new land use and transport interaction model for London and its surrounding regions*. WSP Group, University of Cambridge. Cambridge.

Kessides, Christine (2006). *The Urban Transition in Sub-Saharan Africa: Implications for Economic Growth and Poverty Reduction*. The Cities Alliance, Washington D.C.

King, Kathleen , Polebitski, Austin , Traynham, Lee for Professor Paul Waddell. *Seattle Water Demand Forecast Model*. University of Washington, Seattle, Washington, USA.

Kwapong, Dr. O. Adwoa Tiwaah Frimpong (2008). *Urban Development and Poverty Reduction: Some Institutional Issues*. Institute of Adult Education, University of Ghana and the Cities Alliance: Ghana's Municipal Finance and Management Initiative. Originally printed in the Ghanaian Times on February 5 and 6, 2008.

Larbi, Odame W. (2009). *Ghana: Equity Implications of Land Certification*, Presentation. Land Administration Project, Ministry of Lands, Forestry and Mines, Republic of Ghana.

Long, J. Scott, Freese, Jeremy (2006). *Regression Models for Categorical Dependent Variables Using Stata*. Stata Press, College Station, Texas, USA.

Mabogunje, Professor Akin L. (2005). *Global Urban Poverty Research Agenda: The African Case*. Technical Committee on Housing and Urban Development and Comparative Urban Studies Project of the Woodrow Wilson International Center for Scholars. Abuja, Nigeria and Washington D.C., USA.

Genoese, Massimo, Sensfuß, Frank, Weidlich, Anke, Möst, Dominik, and Rentz, Otto (2005). *Development of an agent-based model to analyse the effect of renewable energy on electricity markets*. Institute for Industrial Production, University of Karlsruhe. Karlsruhe, Germany.

Meibom, Peter, Morthorst, Erik Poul, Nielsen, Lars Henrik, Weber, Christoph, Sander, Kai, Swider, Derk Ravn, Hans (2003). *Power System Models: A Description of Power Markets and Outline of Market Modelling in Wilmar*. Risø National Laboratory, Roskilde, Denmark.

Morrison, Robbie, Wittmann, Tobias, Heise, Jan, and Bruckner, Thomas (2005). *Policy Oriented Energy System Modeling with Xeona*. Institute for Energy Engineering, Technische Universität Berlin. Berlin.

Narayan, Paresh Kumar, Smyth, Russell (2008). *Multivariate granger causality between electricity consumption, exports and GDP: Evidence from a panel of Middle Eastern countries*. *Energy Policy* 37 (2009) 229–236

National Development Planning Commission of Ghana (2005). *Growth and Poverty Reduction Strategy (GPRS II) (2006 - 2009)*: Republic of Ghana.

Nexant Inc. (2004a). *West Africa Regional Transmission Stability Study - Project Inception Report*: Prepared for USAID and ECOWAS Secretariat.

Nexant Inc. (2004b). *West Africa Regional Transmission Stability Study - Volume 2: Master Plan*: Prepared for USAID and ECOWAS Secretariat.

Nexant Inc. (2004c). *West Africa Regional Transmission Stability Study - Volume 3: Stability Study & Operational Analysis* Prepared for USAID and ECOWAS Secretariat.

Nexant Inc. (2004d). *West Africa Regional Transmission Stability Study - Volume 4: Implementation*

*Strategy*: Prepared for USAID and ECOWAS Secretariat.

North, M., Conzelmann, G., Koritarov, V., Macal, C., Thimmapuram, P., & Veselka, T. (2002). *ELaboratories: Agent-Based Modeling of Electricity Markets*: Argonne National Laboratory.

North, M.J., Tatara, Eric, Collier, N.T., Ozik, J. (2006). Visual Agent-Based Model Development with REPASt Symphony. Argonne National Laboratory, Argonne, Illinois, USA.

Obeng-Asiedu, Patrick (2004). Allocating Water Resources for Agricultural and Economic Development in the Volta River Basin. Center for Development Research (ZEF), GLOWA-Volta Project. Bonn, Germany.

Obeng-Odoom, Franklin (2009). The Future of our Cities. *Cities* 26, 49–53.

Franklin Obeng-Odoom (2009). Spatial Political Economy - An Urban Twist, Presentation. Department of Political Economy, University of Sydney, Australia.

Franklin Obeng-Odoom (2009). Transforming Third World Cities Through Good Urban Governance: Fresh Evidence. Theoretical and Empirical Researches in Urban Management Number 1(10). Department of Political Economy, University of Sydney, Australia

Royal Danish Ministry of Foreign Affairs, & Energy Commission of Ghana. (2003). *Indigenous Energy Resource Catalogue*: Kwame Nkrumah University of Science and Technology.

Sensfuß, F., & Genoese, M. (2006). *Agent-based simulation of the German electricity markets-An analysis of the German spot market prices in the year 2001*: Fraunhofer Institute for Systems and Innovation Research.

Sun, J., & Tesfatsion, L. (2006a). *DC Optimal Power Flow Formulation and Solution Using QuadProgJ*: Iowa State University.

Sun, J., & Tesfatsion, L. (2006b). *Dynamic Testing of Wholesale Power Market Designs: An Open- Source Agent-Based Framework*: Iowa State University.

The World Bank (2008). Data Sheet for Project Paper for Land Administration Project. Project ID: P071157, Country Director: Ishac Diwan, Ghana.

The World Bank (2003). Ghana: Corporatization of Distribution Concessions through Capitalization. Report 272/03, UNDP and World Bank Energy Sector Management Assistance Programme. Washington, DC.

The World Bank (2005). Power Sector Reform in Africa: Assessing Impact on Poor People. Report 306/05, Energy and Water Department, UNDP and World Bank Energy Sector Management Assistance Programme. Washington, DC.

The World Bank & MIGA. (2003). Project Appraisal Document for A Land Administration Project, Report No.: 25913. AFTS4, Country Department 10, Africa Regional Office.

The World Bank & MIGA. (2007). Project Appraisal Document for An Urban Transport Project, Report No.: 39750-GH. Transport Sector, Africa Region.

The World Bank & MIGA. (2004). Project Appraisal Document for An Urban Water Project, Report No.: 28557-GH. Water and Urban 2, Country Department 10, Africa Region.

The World Bank (2007). Project Information Document Appraisal Stage. Report No.: AB2813, Ghana Urban Transport Project, General Transportation Sector, Africa.

The World Bank & MIGA. (2004). Project Appraisal Document for the West African Gas Pipeline Project (No. 30335-AFR).

United Nations (2006). *The Millennium Development Goals Report*. New York City.

United Nations (2006). World Urbanization Prospects: The 2005 Revision. Department of Economic and Social Affairs: Population Division. New York, 2006:

Veit, D., Fichtner, W., & Ragwitz, M. (2004). *Agent-based Computational Economics in Power Markets – Multi-agent Based Simulation as a Tool for Decision Support*: University of Karlsruhe.

Veit, D., & Weidlich, A. (2006). Simulating the dynamics in two-settlement electricity markets via an agent-based approach. *International Journal of Management Science and Engineering Management*, 1(2), 83-97.

Ventosa, M., Baíllo, Á., Ramos, A., & Rivier, M. (2005). Electricity market modeling trends *Energy Policy*, 33 (7), 897-913.

Waddell, Paul, Wang, Liming, Liu, Xuan (2007). UrbanSim: An Evolving Planning Support System for Evolving Communities. University of Washington and Southeast Michigan Council of Governments. Center for Urban Simulation and Policy Analysis, University of Washington. Seattle, Washington, USA.

Weidlich, A., Sensfuß, F., Genoese, M., & Veit, D. (2004). *Studying the effects of CO2 emissions trading on the electricity market: A multi-agent-based approach*: University of Karlsruhe.

Weidlich, A., & Veit, D. (2006). *Bidding in Interrelated Day-Ahead Electricity Markets - Insights from an Agent-Based Simulation Model*: University of Karlsruhe.

Wheaton, Bill, Chasteen, Bernadette, Presentation (2005). Generating Synthetic Populations Using Public Microdata. RTI International. Research Triangle Park, North Carolina, USA.

Yankson, Paul W. K., Kofie, Richard Y., Moller-Jensen, Lasse (2004). Monitoring urban growth: urbanisation of the fringe areas of Accra. Legon, Ghana.

Ye, Xin, Konduri, Karthik, Pendyala, Ram M., Sana, Bhargava, Waddell, Paul (2009). A Methodology to Match Distributions of Both Household and Person Attributes in the Generation of Synthetic Populations. Transportation Research Board and Department of Civil and Environmental Engineering, Arizona State University. Tempe, Arizona, USA.

## Acknowledgements

First I would like to give thanks to the heavenly Father almighty and his son Jesus Christ, for guiding, protecting and empowering me on my walk of life. Also, I want to recognize my parents Dennis and Mary Frazier for providing me with the environment needed for cultivating and strengthening my faith.

At the Zentrum für Entwicklungsforschung I have many people to give thanks, first and foremost Dr. Guenter Manske and Frau Rosemarie Zabel for reviewing my application and making recommendation to the ZEF C Sekretariat. Equally so, I want to recognize Prof. Dr. Paul L.G. Vlek for accepting me into the program, supporting me throughout my time of study, encouraging me to join the GLOWA-Volta project, sending me to Ghana and in general being an excellent mentor. I should also give special mention to Charles Rodgers and Jens Liebe, who were the GLOWA-Volta project coordinators in Bonn, during my time of research.

The number of people to thank in Accra, Ghana for assisting and supporting me with my work is in reality countless, but here I will attempt to give special thanks to those persons who were most central. First I want to recognize Rosalind Quartey from the Ghana Statistical Service for her hard work, assistance, provisions, project management, and perhaps most importantly, hospitality during my many months and years while I lived in Kokomlemle, Accra. I would also like to give special mention to Isaac who worked for Rosalind in her Ministries office during the time I was developing spatial interpretations of the GLSS5. I would also like to take this opportunity to recognize another individual who promoted me an immeasurable amount, Professor E. Owusu-Bennoah, who was the Director General of CSIR in Accra during my research. Prof. Owusu-Bennoah and his assistant Edward Decker, wrote many many letters of introduction, recommendation and made positive accounts of my work to several members within the Ghanaian professional community, including assisting with my ability to work closely with the Electricity Company of Ghana.

I would also like to give a very special point of recognition to Bernard Abeiku Arthur, Director of Transportation, for also providing me with important pointers regarding current and ongoing work related to infrastructure development and the World Bank. Additionally, I would like to acknowledge the collaboration and incorporation of my efforts and work by Dr. Odame Larbi, in particular my participation in the Land Administration Project, as well as his efforts to move me forward within his Ghanaian network of Professionals. I would also like to give recognition to Mr. Patrice Afenyo at ECG as well as Mr. Dorney C.J.Y. Aggey and his assistants Crown Disu and George Appiah-Kubi for their very valuable provisions. Finally, I would like to mention the efforts made by Edward P. Karbo, Director of the Town and Country Planning Department as well as his intelligent and very helpful assistant Alhassan Mohammed, who personally provided me insight and tips that led towards a direct and successful navigation of the places and people I needed to meet during my field research.

There are also several persons from IWMI I would like to make a mention, since this field office served as my beginning point while in Accra, in more than one regard. A very special thanks to Dr. Boubacar Barry for all of his helpful provisions, including office space at IWMI, use of the dark blue Galloper, which I drove throughout Accra nearly everyday, as well as providing me with a very nice bed and room in his home located in Agirigano. I would also like to recognize my colleague and good friend Daniel Ofori for providing administrative assistance and project management during my months and years in Accra, as well as, from afar, while I was sitting in Bonn, either preparing for a new trip or completing paperwork from the last one. In this same regard, I should also give mention to Frau Hagedorn-Mensah and her assistant Rosewitha in the ZEF project finance office, for their patience and understanding with my many questions regarding proper procedures and correctly completed paperwork. Back in Accra, I also would like to mention the administrative staff at IWMI, including drivers Salisu Aidam, Eli Sokpoli, Kwesi, Samiru as well as the administrative staff, Linda Beccles-Adjepong and her assistant Debra.

There are also a countless number of colleagues from ZEF, nearly all of whom eventually would become close friends, that I want to recognize for their contributions towards the successful completion of my doctoral studies. First I want to recognize Flavia Feitosa for her countless contributions, some of which were intellectual, but most of which were personal or even trivial, yet have become so much a part, of who I am today. I also would like to recognize the assistance of my very good friend Edward Nketiah-Amponsah for all his help in both Bonn and Accra. I would also like to mention several of my classmates, who provided encouragement and friendship during my time in Bonn, including Aibek, Dela, Emmanuel, Ermias, Patricia and Philine. I would also like to give special thanks to Grace Villamor for her friendship. Additionally, I would like to recognize Dr. Quang Bao Le for his advice, comments and input related to my work, and a heartfelt and sincere thanks to Guido Lechters, who is arguably the most important person at ZEF, eventhough he will likely deny this fact!

The most important recognition and thanks goes to my family, my mother and father, Mary and Dennis Frazier, for encouraging me to travel to Bonn and supporting me during my time here. Also to my sister and brother, Amy Heffernan and Benjamin Frazier, as well as my aunt, Linda Welch and grandmother, Jessie McClain. Finally, I want to recognize the love, understanding, support and never ending source of strength of Catherine Wanjiku, who became a part of my life towards the end of this work, but in fact, this time was the most crucial part of my development, progress and final success. God works in mysterious ways, and the gift of Catherine and her beautiful daughter Natalie Wahu, whom I love equally as my own, is a perfect example of this type of heavenly gift. Catherine is the best partner a man could wish to have as well as the best mother a man could ever want for his children. For you, I reserve my utmost and highest acknowledgement and praise.