

ABSTRACT

The authors present an overview of new multiple access schemes based on a combination of code division and multicarrier techniques, such as multicarrier code-division multiple access (MC-CDMA), multicarrier direct sequence CDMA (multicarrier DS-CDMA), and multitone CDMA (MT-CDMA).

Overview of Multicarrier CDMA

Shinsuke Hara, Osaka University

Ramjee Prasad, Delft University of Technology

Code-division multiple access (CDMA) is a multiplexing technique where a number of users simultaneously and asynchronously access a channel by modulating and spread their information-bearing signals with preassigned signature sequences.

Recently, CDMA technique has been considered to be a candidate to support multimedia services in mobile radio communications [1], because it has its own capabilities to cope with asynchronous nature of multimedia data traffic, to provide higher capacity over conventional access techniques such as time-division multiple access (TDMA) and frequency-division multiple access (FDMA), and to combat the hostile channel frequency selectivity. Direct sequence (DS-) and frequency hopping (FH-) CDMA techniques have been subject to extensive research.

On the other hand, the multicarrier modulation scheme, often called orthogonal frequency-division multiplexing (OFDM), has drawn a lot of attention in the field of radio communications. This is mainly because of the need to transmit high data rate in a mobile environment which makes a highly hostile radio channel. To combat the problem, the OFDM seems to be a solution.

It was in 1993, an epoch of CDMA application, that three types of new multiple access schemes based on a combination of code division and OFDM techniques were proposed, such as "multicarrier (MC-) CDMA," "multicarrier DS-CDMA," and "multitone (MT-) CDMA." These schemes were developed by different researchers, namely, MC-CDMA by N. Yee, J-P. Linnartz and G. Fettweis [2], K. Fazel and L. Papke [3], and A. Chouly, A. Brajal and S. Jourdan [4]; Multicarrier DS-CDMA by V. DaSilva and E. S. Sousa [5]; and MT-CDMA by L. Vandendorpe [6]. These signals can be easily transmitted and received using the fast Fourier transform (FFT) device without increasing the

transmitter and receiver complexities, and have the attractive feature of high spectral efficiency due to minimally densely subcarrier spacing.

This article reviews the three types of Multicarrier CDMA schemes, and discusses their advantages and disadvantages in terms of the transmitter and receiver structures, the spectral efficiency and the downlink bit error rate (BER) performance

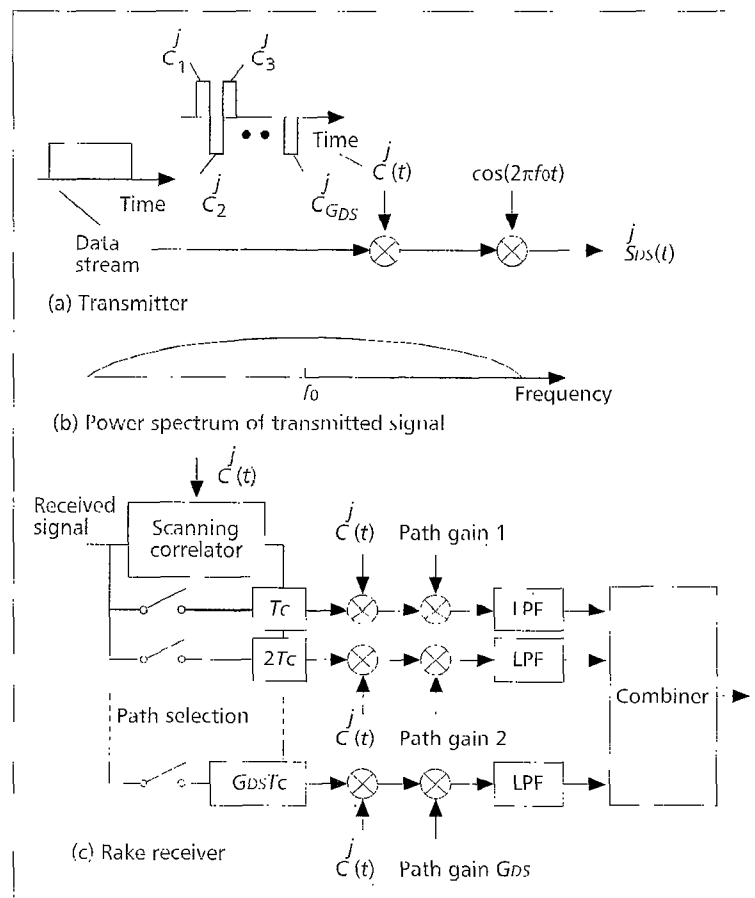

■ Figure 1. DS-CDMA scheme: a) transmitter; b) power spectrum of its transmitted signal; c) receiver.

This article is a minor revised version of an invited paper presented at The Fourth IEEE International Symposium on Spread Spectrum Techniques and Applications (ISSSTA'96), 22-25 Sept., Mainz, Germany.

in a frequency selective slow Rayleigh fading channel.

MULTICARRIER CDMA SCHEMES AND TRANSMITTER STRUCTURES

OFDM scheme is robust to frequency selective fading, however, it has severe disadvantages such as difficulty in subcarrier synchronization and sensitivity to frequency offset and nonlinear amplification, which result from the fact that it is composed of a lot of subcarriers with their overlapping power spectra and exhibits a non-constant nature in its envelope. Therefore, the Multicarrier CDMA schemes inevitably have the same drawbacks. However, the combination of OFDM signaling and CDMA scheme has one major advantage that it can lower the symbol rate in each subcarrier so that a longer symbol duration makes it easier to quasi-synchronize the transmissions.

The Multicarrier CDMA schemes are categorized mainly into two groups. One spreads the original data stream using a given spreading code, and then modulates a different subcarrier with each chip (in a sense, the spreading operation in the frequency domain) [2-4], and other spreads the serial-to-parallel (S/P) converted data streams using a given spreading code, and then modulates a different subcarrier with each of the data stream (the spreading operation in the time domain) [5, 6], similar to a normal DS-CDMA scheme. In order to focus much attention on the difference among these schemes, we first explain a basic DS-CDMA scheme.

DS-CDMA SCHEME

The DS-CDMA transmitter spreads the original data stream using a given spreading code in the time domain. The capability of suppressing multi-user interference is determined by the cross-correlation characteristic of the spreading codes. Also, a frequency selective fading channel is characterized by the superimposition of several signals with different delays in the time domain [1]. Therefore, the capability of distinguishing one component from other components in the composite received signal is determined by the auto-correlation characteristic of the spreading codes.

Figures 1a and b show the DS-CDMA transmitter of the j -th user for binary phase shift keying/coherent detection (CBPSK) scheme and the power spectrum of the transmitted signal, respectively, where G_{DS} denotes the processing gain and $C^j(t) = [C_1^j C_2^j \dots C_{G_{DS}}^j]$ the spreading code of the j -th user.

COMBINATION OF FREQUENCY DOMAIN SPREADING AND MULTICARRIER MODULATION MC-CDMA SCHEME

The MC-CDMA transmitter spreads the original data stream over different subcarriers using a given spreading code in the frequency domain [2-4]. In other words, a fraction of the symbol corresponding to a chip of the spreading code is transmitted through a different subcarrier. In a downlink mobile radio communication channel, we can use the Hadamard Walsh codes as an optimum orthogonal set, because we do not have

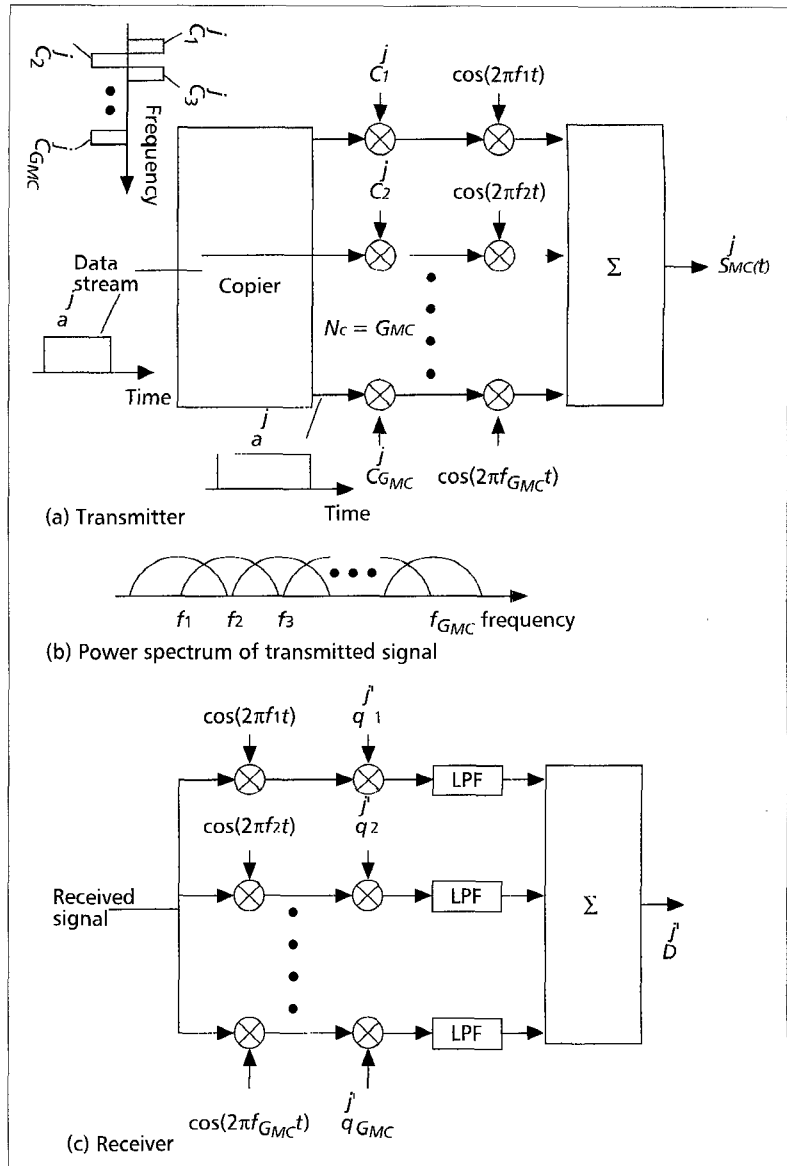

■ Figure 2. MC-CDMA scheme: a) transmitter; b) power spectrum of its transmitted signal; c) receiver.

to pay attention to the auto-correlation characteristic of the spreading codes.

Figures 2a and b show the MC-CDMA transmitter of the j -th user for CBPSK scheme and the power spectrum of the transmitted signal, respectively, where G_{MC} denotes the processing gain, N_C the number of subcarriers, and $C_j^j(t) = [C_1^j C_2^j \dots C_{G_{MC}}^j]$ the spreading code of the j -th user. In [2], a MC-CDMA scheme is discussed assuming that the number of subcarriers and the processing gain are all the same. Therefore, in this figure, we make the same assumption ($N_C = G_{MC}$).

However, we do not have to choose $N_C = G_{MC}$, and actually, if the original symbol rate is high enough to become subject to frequency selective fading, the signal needs to be first S/P-converted before spreading over the frequency domain. This is because it is crucial for Multicarrier transmission to have frequency non-selective fading over each subcarrier [7]. Figure 3 shows the modification to ensure frequency non-selective fading, where T_S denotes the original symbol duration, and the original data sequence is first converted into P parallel sequences, and then each sequence is mapped onto G_{MC} subcarriers ($N_C = P \times G_{MC}$).

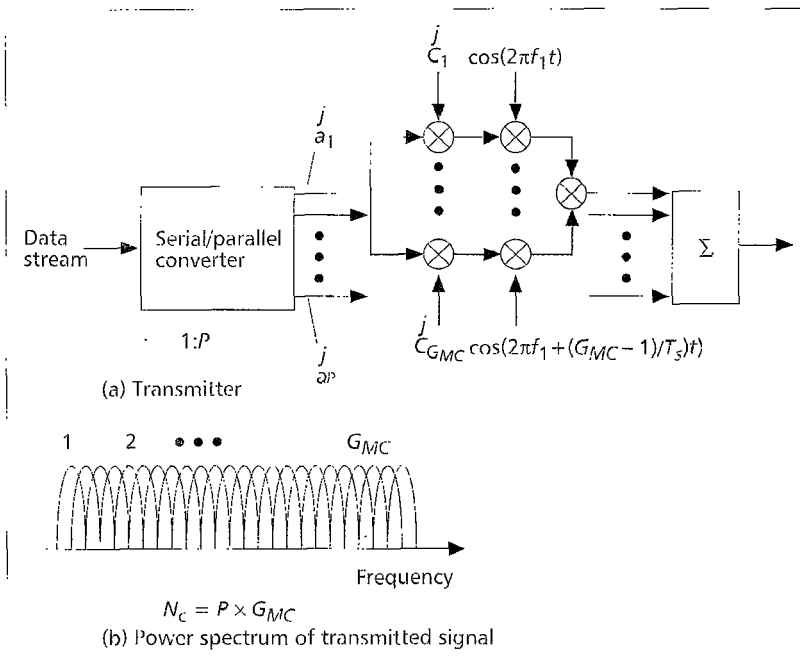

■ **Figure 3.** Modification of MC-CDMA scheme: a) transmitter; b) power spectrum of its transmitted signal.

Also, the proper choice of the number of subcarriers and the guard interval is important in order to increase the robustness against frequency selective fading. Given the property of a frequency selective fast multipath fading channel, there exists the optimal value to minimize the BER in the number of subcarriers and the length of guard interval [8].

COMBINATION OF TIME DOMAIN SPREADING AND MULTICARRIER MODULATION

There are two schemes corresponding to this category. In both schemes, when setting the number of subcarriers to be one, they become equivalent to a normal DS-CDMA scheme.

MULTICARRIER DS-CDMA SCHEME

The Multicarrier DS-CDMA transmitter spreads the S/P-converted data streams using a given spreading code in the time domain so that the resulting spectrum of each subcarrier can satisfy the orthogonality condition with the minimum frequency separation [5]. This scheme is originally proposed for a uplink communication channel, because the introduction of OFDM signaling into DS-CDMA scheme is effective for the establishment of a quasi-synchronous channel.

Figures 4a and b show the Multicarrier DS-CDMA transmitter of the j -th user and the power spectrum of the transmitted signal, respectively, where G_{MD} denotes the processing gain, N_C the number of subcarriers, and $C^j(t) = [C_1^j C_2^j \dots C_{G_{MD}}^j]$ the spreading code of the j -th user.

In [9], a multicarrier based DS-CDMA scheme with a larger subcarrier separation is proposed in order to yield both frequency diversity improvement and narrow band interference suppression. In addition,

a Multicarrier based DS-CDMA scheme, which transmits the same data using several subcarriers, is proposed in [10].

MT-CDMA SCHEME

The MT-CDMA transmitter spreads the S/P-converted data streams using a given spreading code in the time domain so that the spectrum of each subcarrier prior to spreading operation can satisfy the orthogonality condition with the minimum frequency separation [6]. Therefore, the resulting spectrum of each subcarrier no longer satisfies the orthogonality condition. The MT-CDMA scheme uses longer spreading codes in proportion to the number of subcarriers, as compared with a normal (single carrier) DS-CDMA scheme, therefore, the system can accommodate more users than the DS-CDMA scheme.

Figures 5a and b show the MT-CDMA transmitter of the j -th user for CBPSK scheme and the power spectrum of the transmitted signal, respectively, where G_{MT} denotes the processing gain, N_C the number of subcarriers, and $C^j(t) = [C_1^j C_2^j \dots C_{G_{MT}}^j]$ the spreading code of the j -th user.

SYSTEM FEATURES COMPARISON

Table 1 shows the system features comparison. When a rectangular pulse is used in the DS-CDMA scheme, similar to other schemes, the required bandwidths of MC-CDMA and Multicarrier DS-CDMA schemes are almost half as wide as that of DS-CDMA scheme, and the MT-CDMA scheme has almost the same bandwidth as the DS-CDMA scheme. However, when the Nyquist filter with a small rolloff factor is used in the DS-CDMA scheme, the required bandwidths of MC-CDMA and Multicarrier DS-CDMA schemes become comparable with that of DS-CDMA scheme.

RECEIVER STRUCTURES

DS-CDMA SCHEME

A single-user DS-CDMA Rake receiver contains multiple correlators, each synchronized to a different resolvable path in the received composite signal (Fig. 1c). The bit error rate

	DS-CDMA	MC-CDMA	Multicarrier DS-CDMA	MT-CDMA
Symbol duration at subcarrier	T_S	$N_C T_S / G_{MC}$	$N_C T_S$	$N_C T_S$
The number of subcarriers	(1)	N_C	N_C	N_C
Processing gain	G_{DS}	$G_{MC} \approx G_{DS}$	$G_{MD} = G_{DS}$	$G_{MT} = N_C G_{DS}$
Chip duration	T_S / G_{DS}		$N_C T_S / G_{MD}$	$N_C T_S / G_{MT}$
Subcarrier separation		$1/T_S$	$G_{DS} / (N_C T_S)$	$1 / (N_C T_S)$
Required bandwidth (main lobe)	G_{DS} / T_S Nyquist filter with roll-off factor ≈ 0	$(N_C + 1) / N_C \cdot G_{MC} / T_S$	$(N_C + 1) / N_C \cdot G_{MD} / T_S$	$(N_C - 1 + 2G_{MT}) / (N_C T_S)$

■ **Table 1.** System features comparison.

(BER) performance depends on how many fingers the Rake receiver employs. Usually, a 1, 2, 3, or 4-finger Rake receiver is used depending on hardware limitation. Also, when the Nyquist filters are introduced in the transmitter and receiver for base band pulse shaping, the Rake receiver may wrongly combine paths. This is because noise causing distortion in an auto-correlation characteristic often results in wrong correlation. In a DS-CDMA system based on the Rake structure, the system capacity is limited by self-interference (SI) and multiple access interference (MAI), which result from the imperfect auto-correlation characteristic and imperfect cross-correlation characteristic of spreading codes, respectively.

A single-user receiver treats the received signals due to other active users as stationary interference, while in a multi-user detection (MUD), the receiver jointly detects those signals in order to mitigate the nonorthogonal properties of the received signals. As a result, the performance is much improved. However, it can be concluded that it is difficult for the DS-CDMA receivers to make full use of the received signal energy scattered in the time domain.

MC-CDMA SCHEME

In an MC-CDMA receiver the received signal is combined, in a sense, in the frequency domain, therefore, the receiver can always employ all the received signal energy scattered in the frequency domain. We believe that this is the main advantage of the MC-CDMA scheme over other schemes. However, through a frequency selective fading channel, all the subcarriers have different amplitude levels and different phase shifts (although they have high correlation among subcarriers), which results in the distortion of the orthogonality among users.

Figure 2c shows the MC-CDMA receiver of the j' -th user, where after the serial-to-parallel conversion, the m -th subcarrier is multiplied by the gain q_m to combine the received signal energy scattered in the frequency domain. The decision variable is given by

$$D^{j'} = \sum_{m=1}^{G_{MC}} q_m y_m \quad \text{with} \quad y_m = \sum_{j=1}^J z_m^j a^j c_m^j + n_m.$$

Here, y_m and n_m are the complex baseband component of the received signal after down-conversion with subcarrier frequency synchronization and the complex additive Gaussian noise at the m -th subcarrier, respectively, z_m^j and a^j are the complex envelop of the m -th subcarrier and the transmitted symbol for the j -th user, respectively, and J is the number of active users. We can assume $z_m^j = z_m$ ($j = 1, 2, \dots, J$) in a downlink channel.

ORTHOGONALITY RESTORING COMBINING (ORC)

In a downlink channel, choosing the gain as $q_m^{j'} = c_m^{j'} z_m^* / |z_m|^2$, the receiver can eliminate the multiuser-interference perfectly [4, 7]:

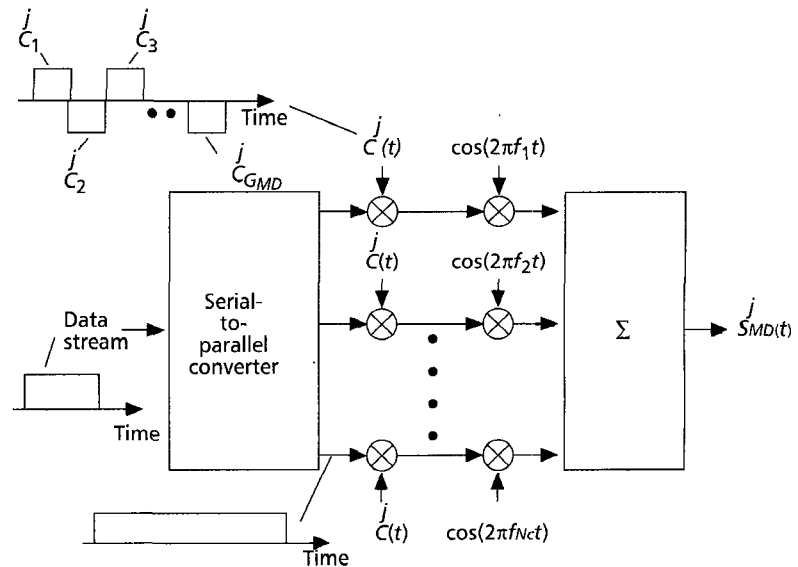

(a) Transmitter

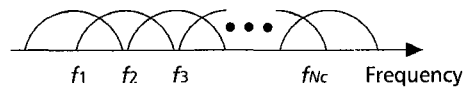

(b) Power spectrum of transmitted signal

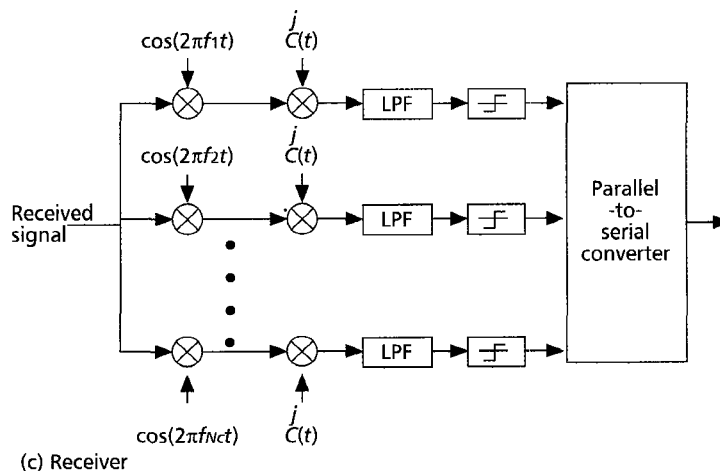

(c) Receiver

■ Figure 4. Multicarrier DS-CDMA scheme: a) transmitter; b) power spectrum of its transmitted signal; c) receiver.

$$D^{j'} = a^{j'} + \sum_{m=1}^{G_{MC}} c_m^{j'} z_m^* / |z_m|^2 n_m.$$

However, low-level subcarriers tend to be multiplied by high gains, and the noise components are amplified at weaker subcarriers. This noise amplification effect degrades the BER performance, although there is no error floor in this method.

CONTROLLED EQUALIZATION (CE)

This method suppresses the excessive noise amplification effect in the orthogonality restoring detection. The decision is made based on the sum of base band components of subcarriers whose amplitudes are larger than a detection threshold:

$$D^{j'} = a^{j'} + \sum_{m=1}^{G_{MC}} c_m^{j'} z_m^* / |z_m|^2 u(|z_m| - \gamma) y_m.$$

Here, γ and $u(\cdot)$ are the detection threshold and the unit step function, respectively. For a given signal-to-noise energy per bit (E_b/N_0), there exists an optimal threshold to minimize the BER.

Access scheme	Detection strategy	Uplink	Downlink
DS-CDMA	Rake combiner MUD	✓ ✓	✓
MC-CDMA	ORC		✓
	CE		✓
	EGC	✓	✓
	MRC	✓	✓
	MMSEC		✓
	ML MUD		✓
	EGC-EGC MUD		✓
	ORC-MRC MUD		✓
	CE-ML MUD		✓
	DIC		✓
	MMSEIC		✓
Multicarrier DS CDMA	Non-rake receiver	✓	
MT-CDMA	Rake combiner	✓	
	DFE	✓	
	LE	✓	
	JEIC	✓	

■ Table 2. Detection strategies comparison.

EQUAL GAIN COMBINING (EGC) AND MAXIMUM RATIO COMBINING (MRC)

The gains for the equal gain combining and the maximum ratio combining are given by $q_m^j = c_m^j z_m^{j*} / |z_m^j|$ (EGC) and by $q_m^j = c_m^j z_m^{j*} / (|z_m^j| + N_0)$ (MRC), respectively [2]. In the case of one user, the maximum ratio combining method can minimize the BER.

MINIMUM MEAN SQUARE ERROR COMBINING (MMSEC)

In a downlink channel, this method estimates the transmitted symbol a^j by the linear sum [4]:

$$\hat{a}^j = \sum_{m=1}^{G_{MC}} q_m^j y_m.$$

Based on the minimum mean square estimation (MMSE) criterion, the error must be orthogonal to all the baseband components of the received subcarriers: $(a^j - \hat{a}^j) y_m = 0$ ($m = 1, 2, \dots, G_{MC}$). The gain is given by $q_m^j = c_m^j z_m^{j*} / (|z_m^j|^2 + N_0)$. Here, N_0 is the noise power. Note that for small $|z_m^j|$, the gain becomes small to avoid the excessive noise amplification while for large $|z_m^j|$, it becomes in proportion to the inverse of the subcarrier envelop $z_m^{j*} |z_m^j|^2$ in order to recover the orthogonality among users. In [4], a method based on the MMSE criterion is proposed, which adaptively estimates the optimum gains taking account of correlation among subcarriers.

MAXIMUM LIKELIHOOD MULTI-USER DETECTION (ML MUD)

When all the users know z_m^j and c_m^j for $j = 1, 2, \dots, J$ and $m = 1, 2, \dots, G_{MC}$, this method finds a set of a^j ($j = 1, 2, \dots, J$) to minimize the following likelihood function [3]:

$$\Lambda = \sum_{m=1}^{G_{MC}} \left| y_m - \sum_{j=1}^J z_m^j a^j c_m^j \right|^2.$$

This method is applicable to both uplink and downlink channels, but the complexity of this detection method grows exponentially as the number of users increases.

EGC-EGC MULTI-USER DETECTION (EGC-EGC MUD)

In a downlink channel, this method first estimates a set of a^j ($j = 1, 2, \dots, J, j \neq j'$) by the equal gain combining:

$$D^j = \sum_{m=1}^{G_{MC}} c_m^j z_m^{j*} / |z_m^j| y_m \quad (j = 1, 2, \dots, J, j \neq j'),$$

and then estimates $a^{j'}$ by the equal gain combining after removing the multiple user interference component from the received signal:

$$D^j = \sum_{m=1}^{G_{MC}} c_m^j z_m^{j*} / |z_m^j| \left(y_m - \sum_{j=1, j \neq j'}^J z_m^j \hat{a}^j c_m^j \right).$$

This method requires knowledge of the spreading codes assigned to all the active users.

ORC-MRC MULTI-USER DETECTION (ORC-MRC MUD)

In a downlink channel, this method first estimates a set of a^j ($j = 1, 2, \dots, J, j \neq j'$) by the orthogonality restoring detection, and then estimates $a^{j'}$ by the maximum ratio combining method after removing the multiple user interference component from the received signal [7]. If the decisions for other users are correct, this method can minimize the BER. This method also requires knowledge of the spreading codes assigned to all the active users.

CE-ML MULTI-USER DETECTION (CE-ML MUD)

In a downlink channel, this method first estimates a^j ($j = 1, 2, \dots, J$) by the controlled equalization, and then estimates a different set of a^j based on the maximum likelihood criterion. This method needs to know the spreading codes assigned to all the active users, and requires the estimation of z_m .

DECORRELATING AND MMSE INTERFERENCE CANCELERS (DIC AND MMSEIC)

These methods cancel MAI by adaptively estimating it based on the decorrelation and MMSE criteria, respectively. The DIC tries to decorrelate each canceler output from all the other users bit estimate, while the MMSEIC to minimize the mean square error. They are applicable to both uplink and downlink channels.

MULTICARRIER DS-CDMA SCHEME

Figure 4c shows a Multicarrier DS-CDMA receiver. Usually, it is composed of N_C normal coherent (Non-Rake) receivers, because it is crucial to have frequency non-selective fading over each subcarrier [5]. Therefore, with no forward error correction (FEC) among subcarriers, this scheme can obtain no frequency diversity gain.

MT-CDMA SCHEME

Figure 5c shows a MT-CDMA receiver composed of N_C Rake combiners, each of which has the same structure as the DS-CDMA Rake receiver (Fig. 1c). This is an optimum receiver for an additive white Gaussian (AWGN) channel [6].

The MT-CDMA scheme suffers from intersubcarrier interference, while the capability to use longer spreading codes results in the reduction of SI and MAI, as compared with the spreading codes assigned to a normal DS-CDMA scheme. In a channel where this improvement is dominant, The MT-CDMA scheme can outperform the DS-CDMA scheme.

A decision feedback equalizer (DFE), a linear equalizer (LE), and a linear joint multiple access interference canceler/equalizer (JEIC) suited for frequency selective fast fading channels are also proposed, all of which have multiple input-multiple output (MIMO) type structures based on the MMSE criterion.

DETECTION STRATEGIES COMPARISON

Table 2 shows the detection strategies comparison. For the MC-CDMA scheme, a lot of strategies have been proposed and analyzed for the downlink channel, because of easy subcarrier synchronization and estimation. Multi-user detection techniques are necessary for the MC-CDMA uplink channel even without near/far effect, because the orthogonality among users is totally distorted.

BIT ERROR RATE COMPARISON

So far, some reports have been dedicated to the BER comparison between DS-CDMA and MC-CDMA schemes [1, 7]. In this article, we show computer simulation results on the BER performance of DS-CDMA, MC-CDMA, Multicarrier DS-CDMA, and MT-CDMA schemes in a (synchronous) downlink communication channel [11, 12].

We assume a frequency selective slow Rayleigh fading channel, where there are two paths in the multipath delay profile and each path has the same average power and the delayed path uniformly ranges from 0 to T_S . To make a fair comparison, we assume the processing gains $G_{DS} = 31$ (Gold Codes), $G_{MC} = 32$ (Hadamard Walsh Codes), $G_{MD} = 31$ (Gold Codes), $G_{MT} = 63$ ($N_C = 2$) and 127 ($N_C = 4$) (Gold Codes). Also, we assume a perfect subcarrier synchronization and subcarrier state estimation.

Given a frequency selective fading channel, we can calculate the frequency correlation function defined as the Fourier Transform of the multipath delay profile, which determines the frequency correlation among subcarriers. It is well known that the BER performance depends on the covariance matrix of the channel, in other words, it is uniquely determined by the eigenvalues. Therefore, the BER of DS-CDMA scheme is determined by the eigenvalues of the time domain covariance matrix, while that of MC-CDMA scheme is determined by the eigenvalues of the frequency domain covariance matrix. We showed that the frequency domain covariance matrix has the all the same eigenvalues as the time domain covariance matrix [7]. Therefore, given a frequency selective channel, the best performance of DS-CDMA scheme (for a single user with a perfect auto-correlation characteristic of the spreading code) is all the same as that of MC-CDMA scheme (for a single user). It also implies that we cannot assume an independent characteristic at each subcarrier even if we employ an ideal frequency interleav-

ing and that, considering the FFT operation, the assumption results in a frequency selective fading at each subcarrier. The BER lower bound [13] is given by (the one by 2-branch maximum ratio combiner)

$$BER_{\text{LowerBound}} = \left(\frac{1-\mu}{2}\right)^2 \sum_{l=0}^1 \binom{l+1}{l} \left(\frac{1+\mu}{2}\right)^l$$

$$\text{with } \mu = \sqrt{\frac{E_b/N_0}{2+E_b/N_0}}$$

Figure 6 shows the BER of DS-CDMA scheme for 1-finger Non-Rake (selection combiner) and 2-finger Rake receivers. Even for the case of one user, there is a little difference between 2-finger Rake receiver and the lower bound because of the SI, and as the number of users increases, the BER gradually degrades because of the MAI. The 1-finger Non-Rake receiver, which selects a larger path, always misses a

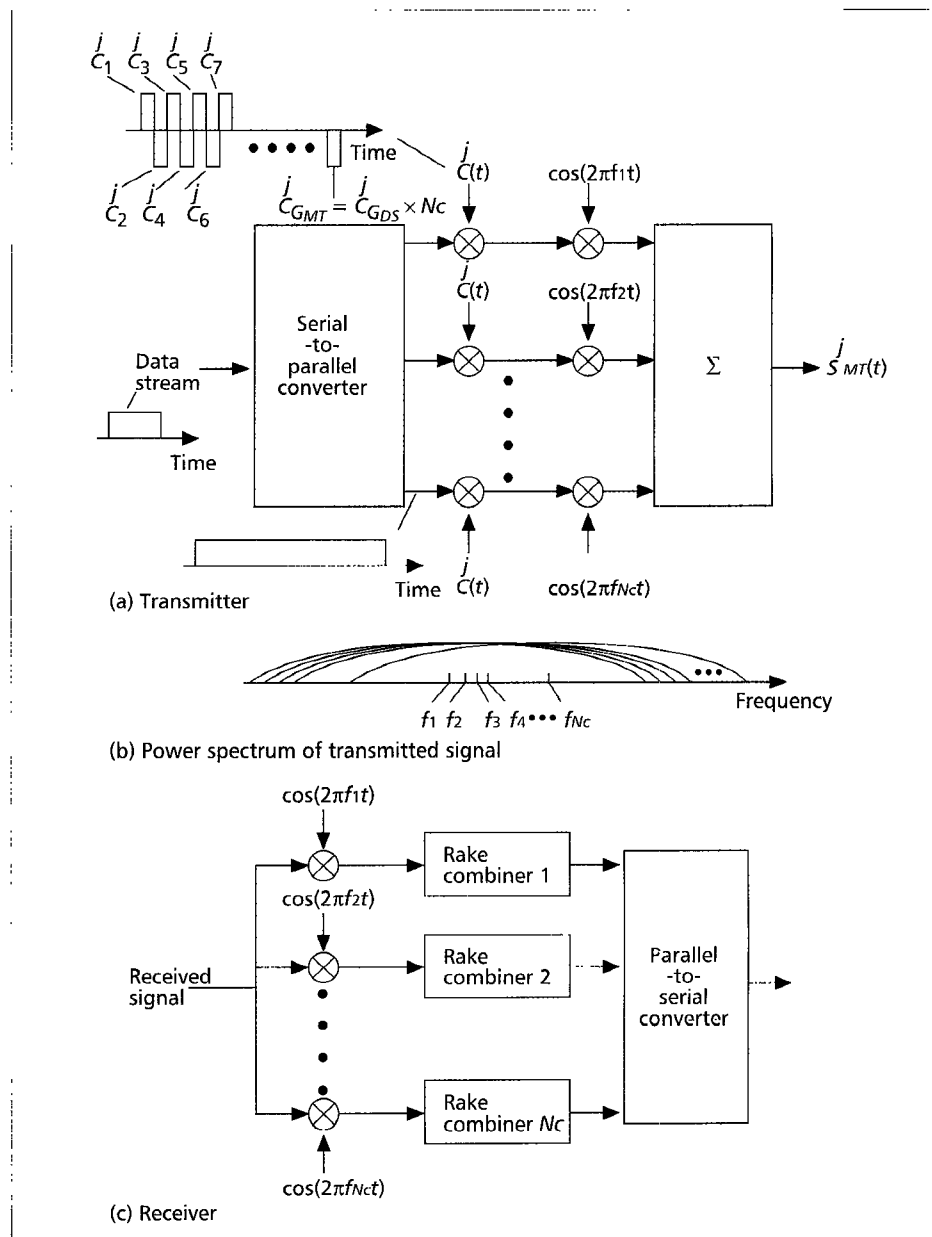

■ Figure 5. MT-CDMA scheme: a) transmitter; b) power spectrum of its transmitted signal; c) receiver.

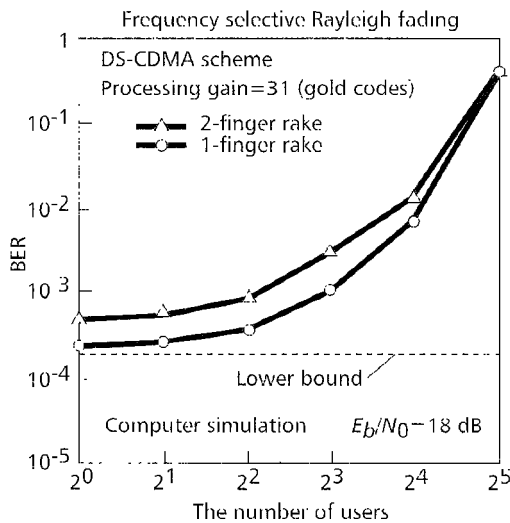

■ Figure 6. BER performance of DS-CDMA scheme.

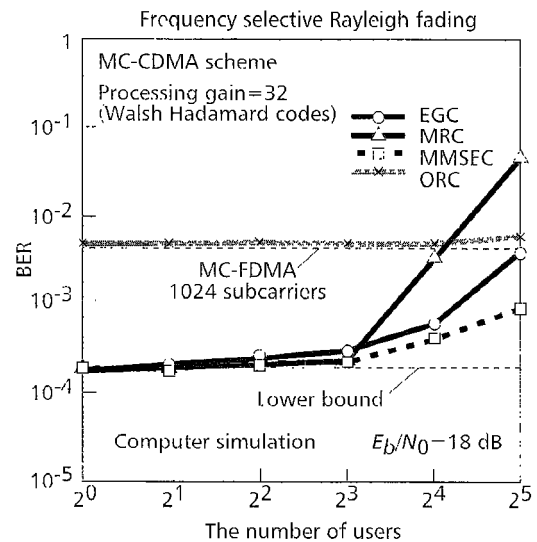

■ Figure 7. BER performance of MC-CDMA scheme.

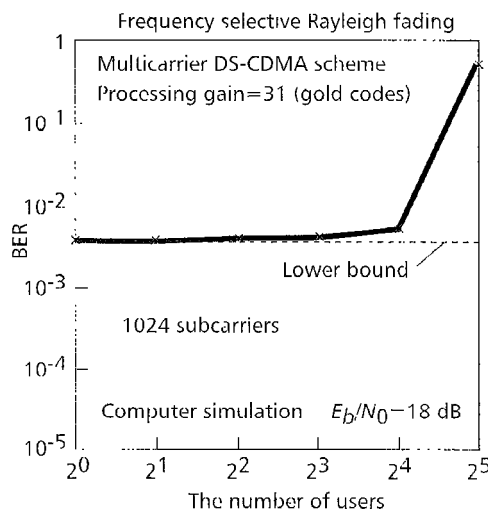

■ Figure 8. BER performance of multicarrier DS-CDMA scheme.

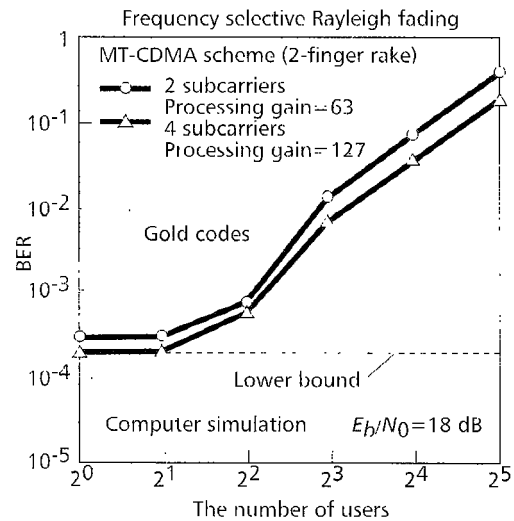

■ Figure 9. BER performance of MT-CDMA scheme.

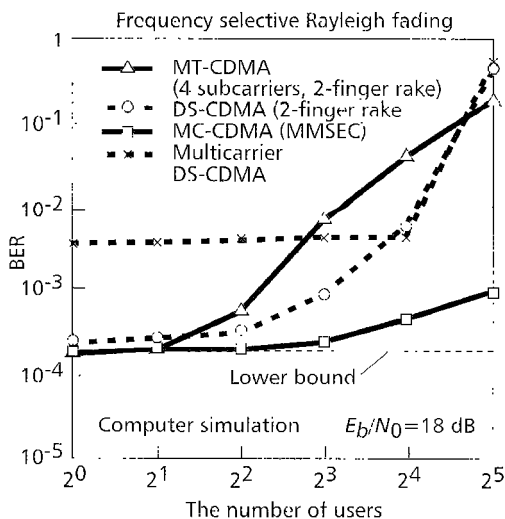

■ Figure 10. BER comparison.

part of the received signal energy, therefore, the performance is worse than that of the 2-finger receiver.

Figure 7 shows the BER of MC-CDMA scheme for ORC, EGC, MRC and MMSEC, respectively, where 1024 subcarriers and 1 percent guard interval are used to have frequency nonselective fading over each subcarrier [7]. Also, in this figure, the performance of MC-FDMA scheme, where 1024 subcarriers are employed as well and a different set of 32 subcarriers is assigned to a different user, is shown. The BER performance of the MC-FDMA scheme [13] is given by

$$BER_{MC-FDMA} = \frac{1}{2} \left(1 - \sqrt{\frac{E_b/N_0}{1 + E_b/N_0}} \right)$$

which is identical to the BER expression for a frequency nonselective slow Rayleigh fading channel. As compared with the MC-FDMA scheme, the MC-CDMA scheme with ORC performs worse. Therefore, we should not use the ORC even if we can perfectly estimate the subcarrier state information. However, the MRC can minimize the BER for the case of one user, because as the number of users increases, the BER rapidly degrades. The EGC, which requires only

subcarrier synchronization, can keep a good BER performance; furthermore, the MMSEC performs better than the EGC.

Figure 8 shows the BER of Multicarrier DS-CDMA scheme, where 1024 subcarriers and 1 percent guard interval are introduced as well. When we do not take account of FEC and interleaving techniques, the BER performance is lower bounded by the same expression for MC-FDMA scheme, because it cannot gain frequency and time diversity effect.

Figure 9 shows the BER of MT-CDMA scheme with 2-finger Rake receiver for $N_C = 2$ and $N_C = 4$, respectively. The MT-CDMA scheme with $N_C = 4$ performs better than that with $N_C = 2$, because, in the channel used in this computer simulation, the intersubcarrier interference, which increases in proportion to the number of subcarriers, less affects the detection process, as compared with the BER improvement effect due to using longer spreading codes.

Figure 10 shows the BER comparison of DS-CDMA scheme with 2-finger Rake receiver, MC-CDMA scheme with MMSEC, Multicarrier DS-CDMA scheme and 2-subcarrier MT-CDMA scheme with 2-finger Rake receiver. It is evident from this figure that the MC-CDMA scheme with MMSEC outperforms all other schemes, although it requires the estimation of subcarrier state information and noise power, and the knowledge of the number of active users.

CONCLUSIONS

This article reviews the Multi-Carrier-based CDMA schemes such as MC-CDMA, Multicarrier DS-CDMA and Multitone CDMA, and discusses their advantages and disadvantages, with a normal DS-CDMA scheme. Computer simulation results have shown that the MC-CDMA scheme with MMSEC is a promising protocol in a 2-path frequency selective slow Rayleigh fading channel. However, more detailed discussions and analyses using different multipath delay profiles are required.

REFERENCES

- [1] R. Prasad, *CDMA for Wireless Personal Communications*, Artech House Publishers, 1996.
- [2] N. Yee, J-P. Linnartz and G. Fettweis, "Multicarrier CDMA in Indoor Wireless Radio Networks," *Proc. of IEEE PIMRC '93*, Yokohama, Japan, Sept. 1993, pp.109-13.
- [3] K. Fazel and L. Papke, "On the Performance of Convolutionally-Coded CDMA/OFDM for Mobile Communication System," *Proc. of IEEE PIMRC '93*, Yokohama, Japan, Sept. 1993, pp.468-72.
- [4] A. Chouly, A. Brajal and S. Jourdan, "Orthogonal Multicarrier Techniques Applied to Direct Sequence Spread Spectrum CDMA Systems," *Proc. of IEEE GLOBECOM '93*, Houston, USA, Nov. 1993, pp.1723-28.

- [5] V. M. DaSilva and E. S. Sousa, "Performance of Orthogonal CDMA Codes for Quasi-Synchronous Communication Systems," *Proc. of IEEE ICUPC '93*, Ottawa, Canada, Oct. 1993, pp. 995-99.
- [6] L. Vandendorpe, "Multitone Direct Sequence CDMA System in an Indoor Wireless Environment," *Proc. of IEEE First Symposium of Communications and Vehicular Technology in the Benelux*, Delft, The Netherlands, Oct. 1993, pp. 4.1-1-4.1.8.
- [7] S. Hara, T-H. Lee and R. Prasad, "BER Comparison of DS-CDMA and MC-CDMA for Frequency Selective Fading Channels," *Proc. of 7th Tyrrhenian International Workshop on Digital Communications*, Viareggio, Italy, Sept. 1995, pp. 3-14.
- [8] S. Hara et al., "Transmission Performance Analysis of Multicarrier Modulation in Frequency Selective Fast Rayleigh Fading Channel," *Wireless Personal Communications*, vol. 2, no. 4, 1995/1996, pp. 335-56.
- [9] S. Kondo and L. B. Milstein, "Performance of Multicarrier DS CDMA Systems," *IEEE Trans. Commun.*, vol. 44, no. 2, Feb. 1996, pp. 238-46.
- [10] E. Sourour and M. Nakagawa, "Performance of Orthogonal Multicarrier CDMA in a Multipath Fading Channel," *IEEE Trans. Commun.*, vol. 44, no. 3, Mar. 1996, pp. 356-67.
- [11] S. Hara and R. Prasad, "DS-CDMA, MC-CDMA and MT-CDMA for Mobile Multi-Media Communications," *Proc. of IEEE VTC '96*, Atlanta, USA, April 1996, pp.1106-10.
- [12] R. Prasad and S. Hara, "An Overview of Multicarrier CDMA," *Proc. of IEEE ISSSTA '96*, Mainz, Germany, Sept. 1996, pp. 107-14.
- [13] J. G. Proakis, *Digital Communications*, Mc-Graw Hill, 2nd ed., 1991.

BIOGRAPHIES

SHINSUKE HARA [M '90] (hara@comm.eng.osaka-u.ac.jp) received B.Eng., M.Eng. and Ph.D. degrees in communication engineering from Osaka University, Osaka, Japan, in 1985, 1987 and 1990, respectively. From April 1990 to March 1996, he was an assistant professor in the Department of Communication Engineering, Osaka University. Since April 1996, he has been with the Department of Electronic, Information, and Energy Engineering, Graduate School of Engineering, Osaka University, and now he is an associate professor. From April 1996 to March 1997, he was a visiting scientist in Telecommunications and Traffic Control Systems Group, Delft University of Technology, Delft, The Netherlands. His research interests include satellite, mobile and indoor wireless communications systems, and digital signal processing.

RAMJEE PRASAD [SM '90] received a B.Sc.(Eng.) from Bihar Institute of Technology, Sindri, India, and M.Sc.(Eng.) and Ph.D. degrees from Birla Institute of Technology (BIT), Ranchi, India, in 1968, 1970, and 1979, respectively. He joined BIT as senior research fellow in 1970 and became associate professor in 1980. During 1983-1988 he was with the University of Dar es Salaam (UDSM), Tanzania, where he became full professor in Telecommunications in the Department of Electrical Engineering in 1986. Since 1988, he has been with the Telecommunications and Traffic Control Systems Group, Delft University of Technology, The Netherlands, where he is actively involved in the area of personal, indoor, and mobile radio communications. He has published over 200 technical papers and authored a book, *CDMA for Wireless Personal Communications*, Artech House (Norwood, MA). He is a coordinating editor and editor-in-chief of *Wireless Personal Communications* and is also an editorial board member of *IEEE Communications Magazine* and *IEE Electronics Communication Engineering Journal*. His current research interest is in wireless networks, packet communications, adaptive equalizers, spread-spectrum CDMA systems, multimedia communications, and wireless ATM.