



(RESEARCH ARTICLE)



## Population dynamics of *Aedes aegypti* (Diptera: Culicidae): Contributions to the prevention of arbovirosis in Villa Clara, Cuba

Rigoberto Fimia Duarte <sup>1,2,\*</sup>, Yusimí Guerra Véliz <sup>2</sup>, David del Valle Laveaga <sup>3</sup>, Rolando J Morales Guerra <sup>2</sup>, Wilfredo Castañeda López <sup>4</sup>, Julio Leiva Haza <sup>2</sup>, Freddy E Zambrano Gavilanes <sup>5</sup> and Frank M Wilford González <sup>2</sup>

<sup>1</sup> Faculty of Health Technology and Nursing, University of Medical Sciences of Villa Clara, Cuba.

<sup>2</sup> Central University "Marta Abreu" of Las Villas, Villa Clara, Cuba.

<sup>3</sup> Academic Area of Health, Maya World University, México.

<sup>4</sup> Provincial Center of Hygiene, Epidemiology and Microbiology of Villa Clara, Cuba.

<sup>5</sup> Faculty of Agronomy Engineering, Technical University of Manabí, Manabí, Ecuador.

GSC Biological and Pharmaceutical Sciences, 2022, 18(02), 173–188

Publication history: Received on 09 January 2022; revised on 10 February 2022; accepted on 12 February 2022

Article DOI: <https://doi.org/10.30574/gscbps.2022.18.2.0066>

### Abstract

Emerging and re-emerging infectious diseases constitute one of the main health problems worldwide. The objective of the research consisted of analyzing the development dynamics of adult mosquito populations of the species *Ae. aegypti* in Villa Clara province, Cuba during the period 2016-2020. The research covered the 13 municipalities of Villa Clara. An observational, descriptive, ecological, retrospective and analytical-statistical (by decision tree/exploratory data analysis) study was conducted. The study was based on the collection of positive samples/number of outbreaks reported in the 13 municipalities of the province, in the different months of the period analyzed, for the mosquito species *Ae. aegypti*, where each sample point corresponded to the number of specimens collected in one of the years covered, with one of the months of the year in question (12 months), the 13 municipalities, and 9 types of reservoirs. This resulted in 7 020 observations, which constitutes the sample size. The presence of the species under analysis was found in the 13 municipalities of the province, with abundant population densities; on the other hand, the variables with the greatest incidence in the population dynamics were: municipality and type of reservoir, with emphasis on the low tank, as the preferred oviposition and breeding site for this species. It is concluded that *Ae. aegypti* has a high capacity for adaptation and high ecological plasticity, with a marked correspondence between the ecology and habitat of the species under analysis.

**Keywords:** Adults; *Aedes aegypti*; Decision tree; Population dynamics; Villa Clara

### 1. Introduction

Emerging and re-emerging infectious diseases constitute one of the health problems that have aroused most interest in different countries around the world in recent years [1-4], as many of them are considered national catastrophes due to the high morbidity they generate, the large number of lives they cost and the cost that these represent from the economic point of view for the country [5-7]. They cease to be health problems to become economic problems, due to their impact on tourism, industry, product exports, in addition to the resources that the health sector must contribute to control such infectious entities [8-10].

\* Corresponding author: Rigoberto Fimia Duarte; Phone: +53-59740716 and ORCID: <https://orcid.org/0000-0001-5237-0810>

Email: [rigoberto.fimia66@gmail.com](mailto:rigoberto.fimia66@gmail.com)

Faculty of Health Technology and Nursing, University of Medical Sciences of Villa Clara, Cuba.

Numerous factors or combination of factors can contribute to the emergence of infectious diseases [11-16]. Already known diseases may spread to new geographic areas, populations, or genetic changes may occur in known organisms. Previously unknown infections may develop in people living or working in changing ecological conditions, which increase their exposure to insect vectors, animal reservoirs or an environment that is the source of new pathogens [16-18].

Millions of people in the world suffer from infections transmitted by arthropod vectors; among them, culicidae are undoubtedly of the greatest hygienic-sanitary importance, because they constitute one of the priority health problems in almost all tropical regions and are responsible for the maintenance and transmission of the pathogens that cause Dengue, Yellow Fever, Zika, Chikungunya and other deadly and debilitating infections. Dengue is a disease of great public health importance in tropical and subtropical areas, where 50 and 100 million cases occur each year [1,2,17,19].

With sporadic presentation, Dengue has emerged as one of the diseases that most affect public health, it manifests itself with important social and economic impacts given its current dispersion, high morbidity and significant mortality of severe cases [1, 2, 18].

The situation of emerging and re-emerging infectious diseases in the Americas is extremely serious [20-22], as there is a high number of infectious diseases, among which dengue deserves special mention, which has spread to numerous countries in the Caribbean and Central American area, in Venezuela, Colombia and Peru and new types of viruses have appeared, resulting in an increase in dengue hemorrhagic fever [23-25]. Yellow fever remains a persistent threat and Chikungunya and Zika have been introduced. Most cases, of arboviral diseases previously emerged are caused by viruses, usually considered to be controlled or of little public health importance, which are transmitted by vector organisms, mainly mosquitoes [26-29].

In Cuba, the incidence of these entities, both parasitic and viral, is undoubtedly a health problem (MINSAP 2016a, b) [30, 31], with a tendency to increase the number of cases, as well as the populations of vector organisms [5, 31, 32]. The control of dengue and its vector is an emerging problem that resists traditional solutions, but requires systems thinking to understand various aspects of the dynamics of this disease. Traditional analytical methods must be suited to the high degree of predictability of these emerging health problems in which many variables are involved [12, 13, 16, 24].

The objective of the research consisted of analyzing the developmental dynamics of *Ae. aegypti* mosquito populations in Villa Clara province, Cuba during the period 2016-2020.

---

## 2. Material and methods

### 2.1. Study area

The research was carried out in the province of Villa Clara, Cuba, whose provincial capital is the municipality of Santa Clara and covered the 13 municipalities that make up the province, which is located in the central region of the island of Cuba (Latitude: 22° 29'40" N, Longitude: 79°28'30" W). In Villa Clara province, specialists of the Provincial Unit of Surveillance and Antivectorial Control (UPVLA) have registered about 316 370 dwellings and/or premises in the general universe, of which 236 391 belong to the urban universe (74.7%) and an average of approximately 1 581 850 tanks used for water storage in these dwellings and/or premises, with conditions for the breeding, proliferation and dissemination of culicidae of this species distributed in the 13 municipalities.

### 2.2. Type of study

Observational, descriptive, ecological, retrospective and analytical-statistical study (based on multivariate analysis, by means of decision tree/exploratory data analysis), in the period from 2016 to 2020.

### 2.3. Population

The population of mosquitoes of the species *Ae. aegypti* (adult phase) of the 13 municipalities that make up the province Villa Clara, Cuba (2016 to 2020).

## 2.4. Sample

The results of the collection of positive samples/number of outbreaks reported in the 13 municipalities of Villa Clara province, in the different months of the period analyzed (2016-2020), of the *Ae. aegypti* mosquito species in the adult phase are presented.

Each sample point (observation) corresponds to the number of specimens collected in one of the years comprised, between 2016 and 2020 (5 years), with one of the months of the year in question (12 months), one municipality of Villa Clara province (13 municipalities) and one type of reservoir (9 types of reservoirs). This resulted in 7 020 observations, which constitutes the sample size. (The sample size was calculated by the generalized multiplication theorem; that is, by multiplying the number of years by the number of months, by the number of municipalities and by the number of types of deposits ( $5 \times 12 \times 13 \times 9 = 7\ 020$ )).

## 2.5. Type of sampling used

Census sampling, which attempts to include the entire population of adult mosquitoes living in the urban universe, although only those detected by vector control workers are included.

## 2.6. Methods and techniques for the collection of information

The documentary review of the records and statistical files existing in the Provincial Unit of Surveillance and Vector Control (UPVLA) and in the Provincial Department of Health Statistics of Villa Clara, where the entire entomological history of the work cycles conceived in the 13 municipalities of the province is compiled, which is periodically reported in statistical tables established for such purposes by the National Directorate of Surveillance and Vector Control (DNVLA) and the Department of Health Statistics of the Ministry of Public Health (MINSAP).

The information collected is based on the work cycles established for surveillance and vector control, aimed at focal work in the universe of dwellings and premises in urban and rural areas of the 13 municipalities of the province, but in the case of our research it was focused on the urban universe (related to the ecology of the vector under study). The periodicity of the cycles is monthly, in the case of this universe.

## 2.7. Information processing

The data were organized by means of the Windows Excel application, by years and months; that is, 11 columns were placed: the first one with the municipalities and the provincial accumulated, the remaining ones with the years and their respective focus.

The second had a total of 14 columns; the first with the years and the average focal point, while the following 12 columns represent the months with their respective focal point and the last one, the total by years, in each of the municipalities of the province. After organizing the data, we proceeded to obtain the time series and trend for each of the variables mentioned, which was reflected in the figures prepared for all the municipalities, according to the variables under analysis.

The following were considered as independent variables: Year, Month, Municipality and Type of deposit, while the dependent or predictor variable was the number of adult *Ae. aegypti* specimens/specimens. The statistical technique used was the decision tree, from which a classification model of the observations was created by considering the influence of the independent variables included in the study.

The method used to grow the tree was the exhaustive CHAID (Chi-square automatic interaction detector), which is an algorithm that allows the automatic detection of interactions by means of Chi-square. At each step, CHAID chooses the independent variable (predictor) that has the strongest interaction with the dependent variable. The categories of each predictor are merged if they are not significantly different with respect to the dependent variable. The comprehensive analysis indicates that all possible splits for each predictor variable are examined, and treats all variables equally, regardless of the type and number of categories.

The depth of the tree was chosen in advance with a value of three (three levels). As restrictions, the minimum number of cases in a parent node was taken as 100, and in a branch node as 50.

### 3. Results

In the research carried out, the following variables were obtained as influential variables: year, municipality and type of deposit. The variable: year was forced to be the first predictor variable, so it gave rise to the first level of the tree. This was done to begin with an analysis of the temporal evolution of the distribution of adult specimens of *Ae. aegypti* in the period analyzed. The second predictor variable was "municipality" (second level of the tree) and the third "type of deposit" (third level of the tree), both identified in that same order by the algorithm, according to their incidence on the distribution of adult *Ae. aegypti* individuals. The variable "month" was excluded from the model, which means that its contribution to the final model was not significant.

As a result, a total of 38 nodes were obtained, of which 28 were terminal. From here on in the text, nodes will be referred to with a capital n followed by the node number (Figure 1)

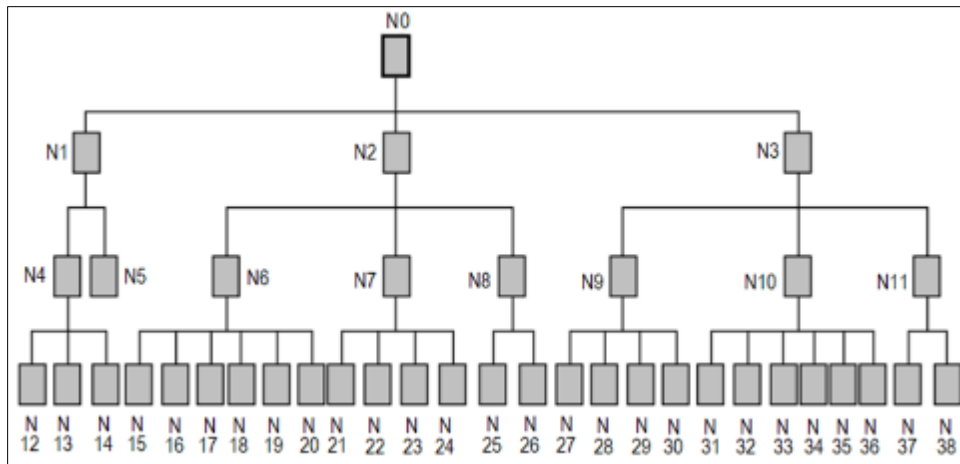

Figure 1 Decision tree map

#### 3.1. Analysis of level zero

N0 includes the total number of observations  $n=7\ 020$ . The mean is 9.3 individuals per observation and the standard deviation is approximately 48, which indicates that there is a great variability in the samples collected (the number of individuals collected varies greatly from one observation to another). For the N0: the mean is 9.31; however, the mode and median are zero, the third quartile is 3. The range was 166, which indicates the existence of several extreme points far away from the center of the data.

#### 3.2. Analysis of the first level of the tree

From N0, starting from the first predictor variable "year", three nodes are derived: N1, N2 and N3 (Figure 2).

N1: This node corresponds to the year 2016, it includes 1 404 observations, representing 20 % of the total observations made in the five years. The mean is 5.5 individuals per observations and the standard deviation is 30.9; indicating high variability.

N2: corresponds to the period from 2017 to 2018. It includes 2 808 observations representing 40 % of the total. The mean is 8.7 individuals per observations and the standard deviation is 46.9.

N3: Corresponds to the years 2019 and 2020. It includes 2 808 observations, with a mean of 11.8 individuals per observation and standard deviation of 55.4 (Figure 2).

A comparison of these three nodes shows that the mean increased, which reflects that the number of individuals per observation increased over the years, indicating that vector control has been decreasing over time.

On the other hand, variability has been high in the three periods determined, with an increase observed over time. This variability indicates that there is high diversification in terms of the action of the independent variables by groups of observations.

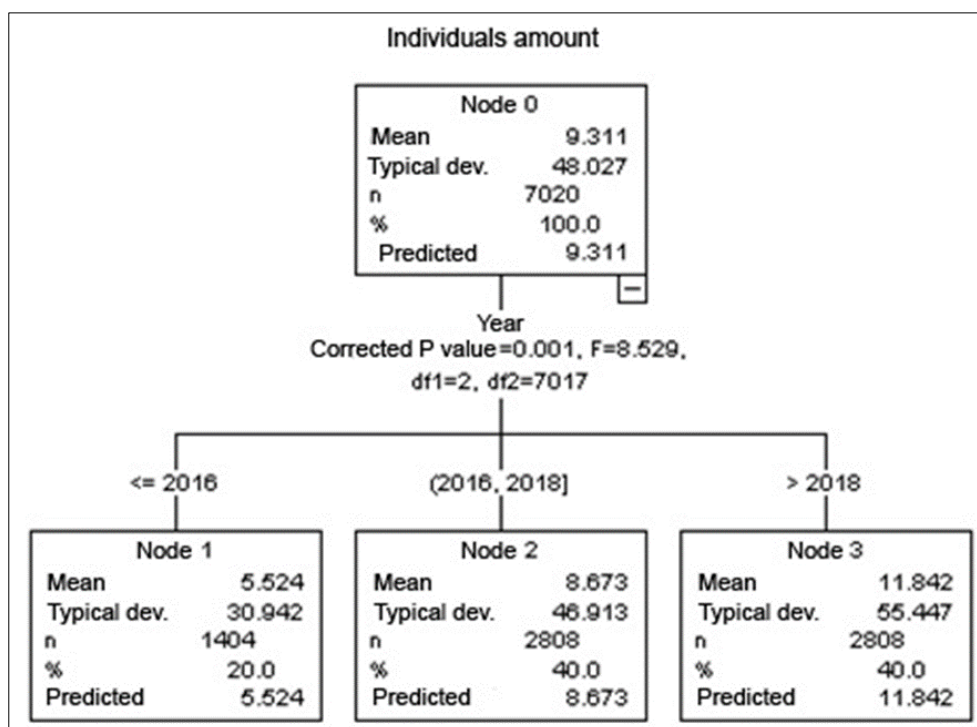

Figure 2 First level of the decision tree

### 3.3. Analysis of the second level of the decision tree

At the second level, the predictor variable was municipality.

In each municipality, 108 observations are included, corresponding to the 9 types of deposits multiplied by the 12 months of the year. In each node, a number of observations is included that depend on the number of municipalities included in that node, so that the number 108 is multiplied by the number of municipalities included in the node in question.

### 3.4. Year 2016 "N1"

N1 gives rise to two nodes: N4 and N5.

N4: groups 12 municipalities: Corralillo, Quemado, Sagua, Encrucijada, Camajuaní, Caibarién, Remedios, Placetas, Cifuentes, Santo Domingo, Ranchuelo and Manicaragua with an average of 2.6 adult specimens per observation and a standard deviation of 12.9. N5 includes only Santa Clara with a mean of 40.8 and a standard deviation of 95.9.

Between N4 and N5, a very marked difference is observed, highlighting the municipality of Santa Clara (N5), with a mean number of adult individuals per observation (40.8), much higher than that of the rest of the municipalities (N4), which is 2.6. The standard deviation is high in both nodes, although in Santa Clara it reaches a much higher value, indicating the high variability of the observations (Figure 3).

### 3.5. Years 2017 and 2018

N2 gives rise to three nodes: N6, N7 and N8.

N6 includes the municipalities: Corralillo, Quemado, Encrucijada, Camajuaní, Caibarién, Remedios, Cifuentes and Santo Domingo, the mean is 1.2 adult individuals per observation and the standard deviation is 3.2.

N7 includes the municipalities: Sagua, Placetas, Ranchuelo and Manicaragua with a mean of 6.9 adult individuals per observation and a standard deviation of 16.9.

N8 includes only Santa Clara with a mean of 75.7 adult individuals per observation and a standard deviation of 150.

Between these three nodes a very marked difference is observed, with an increase in the mean in the same order in which the nodes have been defined (Figure 4).

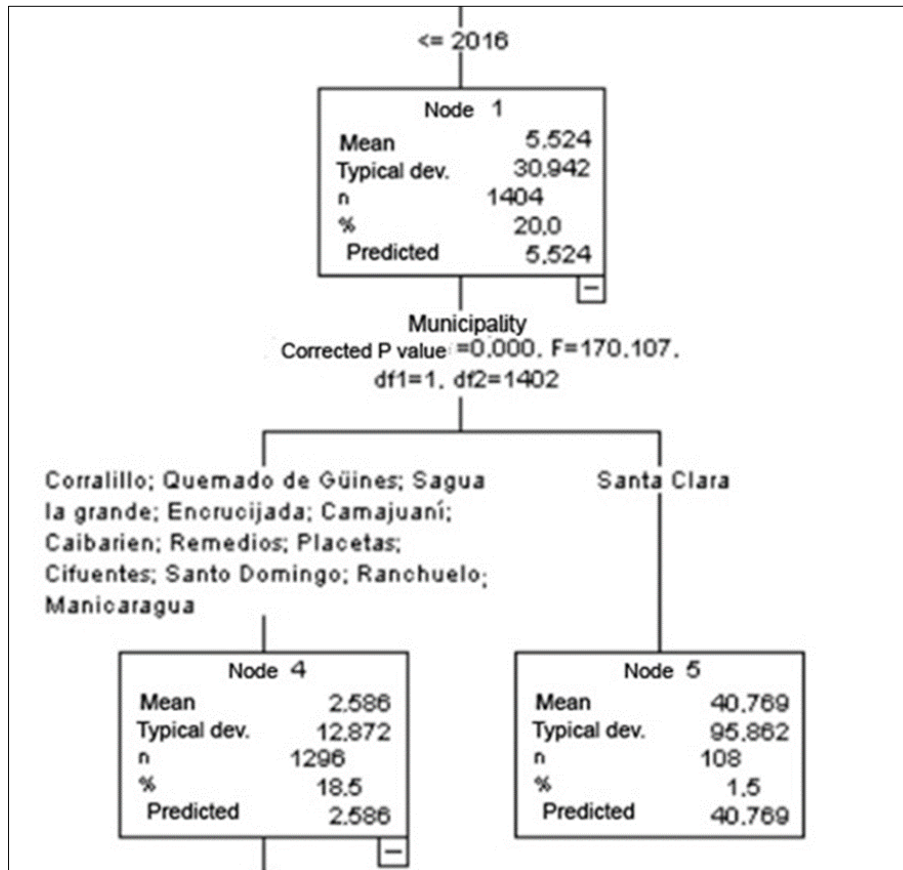

Figure 3 Second level of the decision tree for 2016

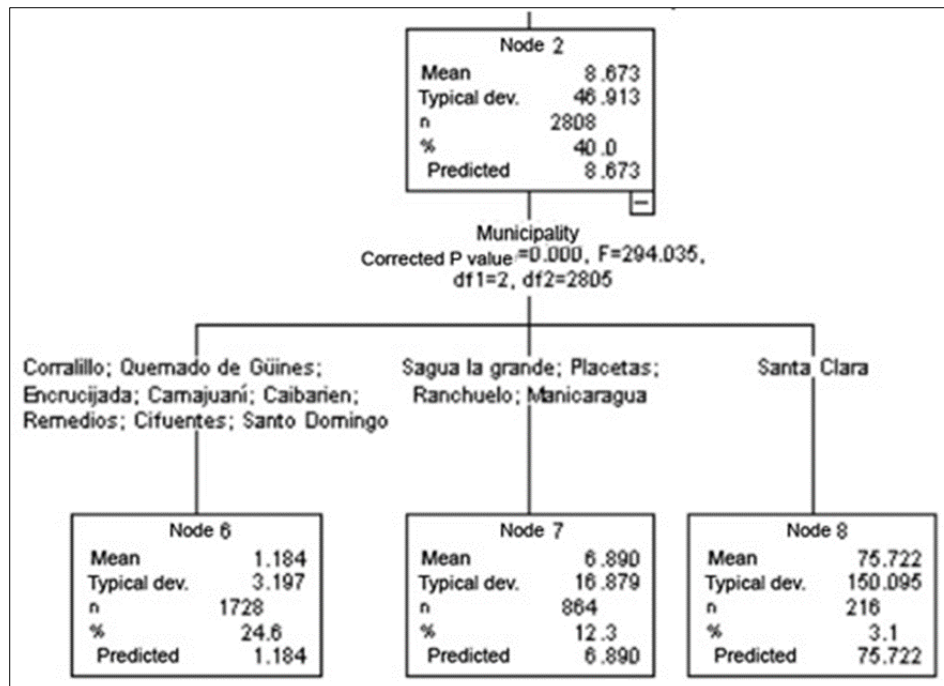

Figure 4 Second level of the decision tree for the period between 2017 and 2018

The municipality Santa Clara remains as the most affected, the same as in 2016, in addition, for this municipality, an increase in the mean by almost double compared to 2016 is observed (Figure 3/ N5). This indicates that the number of adult individuals per observation increased considerably, so it can be said that the municipality of Santa Clara was more affected in 2017 and 2018 than in 2016 (compare N5 in Figure 3 with N8 in Figure 4), however, between 2017 and 2018 no differences were found for this municipality.

As for the rest of the municipalities, which in 2016 were included in the same node (Figure 3 N4) with similar characteristics, already in the period between 2017 and 2018 they form two well differentiated nodes (N6 and N7), highlighting that those included in N6 (Corralillo, Quemado, Encrucijada, Camajuaní, Caibarién, Remedios, Cifuentes and Santo Domingo) have decreased the number of adult individuals per observation (the mean is lower than in 2016, compare N6 with N4), so their epidemiological situation improved; while in the municipalities corresponding to N7, the presence of adults per observations has increased by almost three times, so that their epidemiological situation is more affected than in 2016 (compare N4 with N7).

### 3.6. Years 2019 and 2020

N3 gives rise to three nodes: N9, N10 and N11.

N9 includes the municipalities: Corralillo, Quemado, Encrucijada, Cifuentes and Santo Domingo with a mean of 1.2 adult individuals per observation and a standard deviation of 2.4.

N10 include the municipalities: Sagua, Camajuaní, Caibarién, Remedios, Placetas, Ranchuelo and Manicaragua with a mean of 7.8 adult individuals per observation and a standard deviation of 16.7.

N11 only includes Santa Clara with a mean of 93.2 adult individuals per observation and a standard deviation of 175.6 (Figure 5).

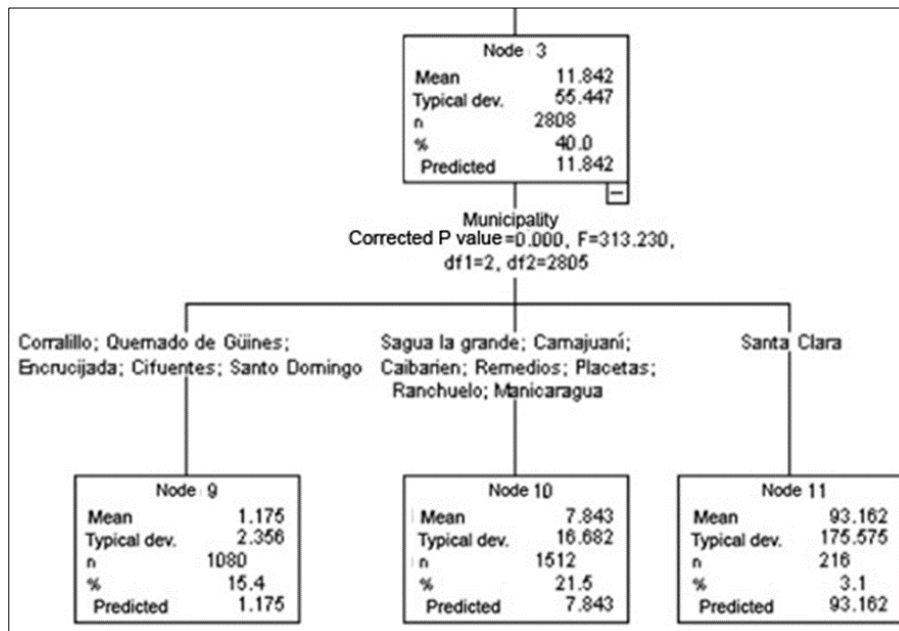

Figure 5 Second level of the decision tree for the period between 2019 and 2020

### 3.7. Analysis of the third level of the decision tree

Regarding the third level of the tree the predictor variable was the type of deposit.

In 2016, N4, gave rise to three nodes, N12, N13 and N14, differentiating the types of tanks into three groups. The highest value of the mean (10,562) corresponded to low tank, which is located in N12. The municipality of Santa Clara (N5) does not present divisions, this is because the possible divisions resulted in nodes with  $n < 50$ , which is restricted by the assumed model (Figure 6)

N6: gives rise to six nodes: N15, N16, N17, N18, N19 and N20. This shows that there are large differences in the number of adult individuals according to the type of tank. It is observed that the type of deposit whose mean number of individuals per observation was higher in "low tank", with a value of 4, 297; followed by the type labeled with "other" with a mean of 2,521 and the rest with means below 1 (Figure 7).

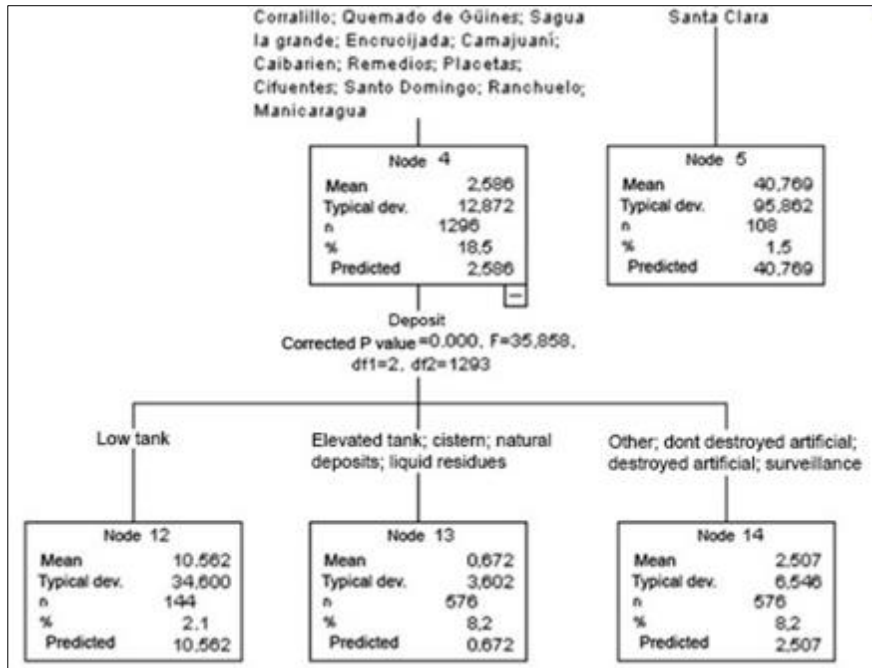

Figure 6 Third level of the decision tree for the type of deposits. Year 2016

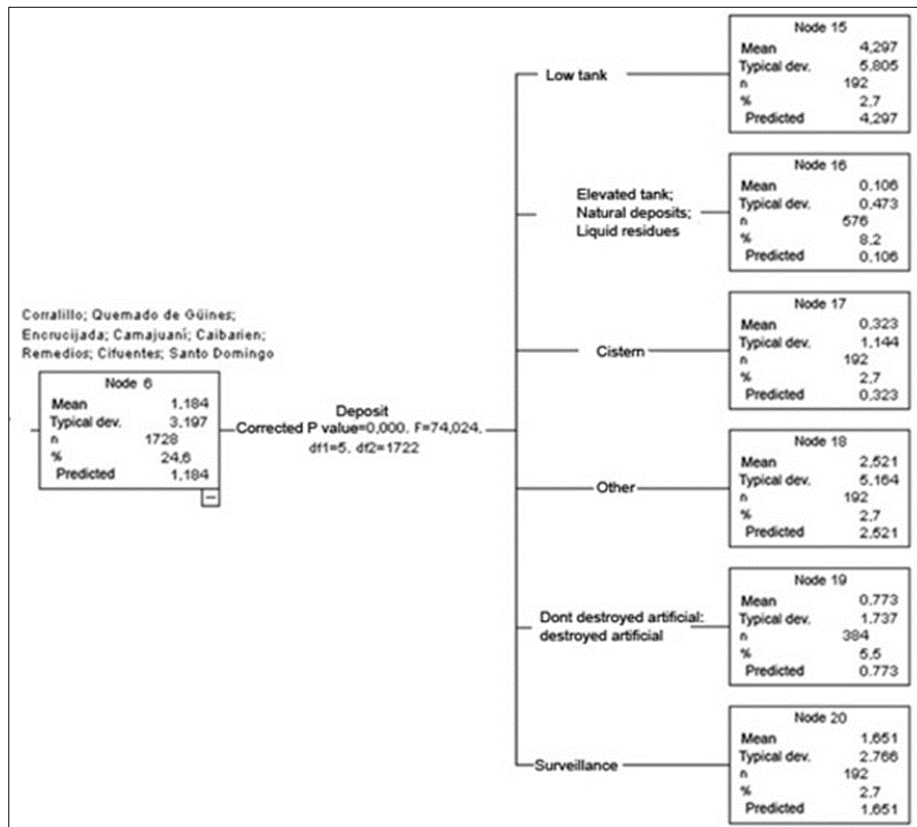

Figure 7 Third level of the decision tree for the period corresponding to 2017-2018 (only N6 and its child nodes are represented)



For 2017-2018, the graph was divided by parent nodes to achieve fit on the sheet.

For N6, it was obtained that the tank type with the highest mean was low tank (mean of 4.297), followed by "other" and "surveillance" and with means of 2.521 and 1.651 respectively, the rest present means below 1 (Figure 7)

In N7 also the type of tank with more individuals per observation was "low tank", with mean of 28.479, followed by "other", "artificial not destroyed" and "artificial destroyed", with mean of 8.573 (this value even higher than the highest for the previous period obtained for "low tank"). Then "elevated tank", "cistern" and "surveillance", with mean of 2.299 and finally "natural reservoirs" and "liquid waste" whose mean 0.458 is below zero (Figure 8).

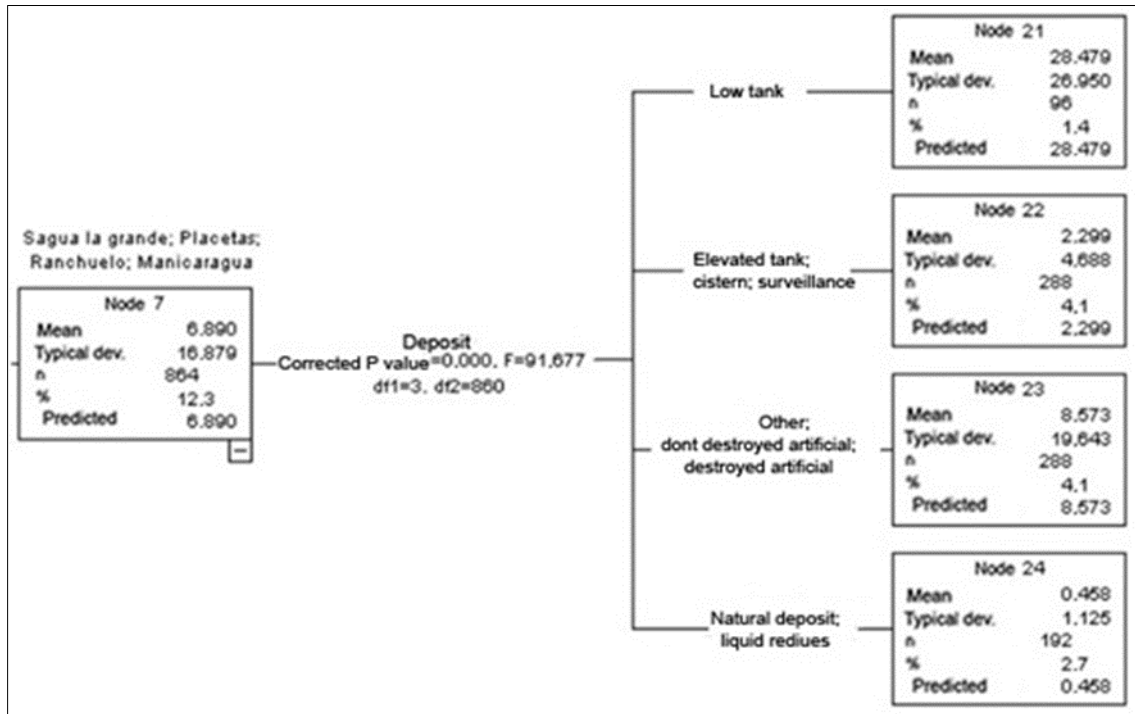

**Figure 8** Third level of the decision tree for the period corresponding to 2017-2018 (only N7 and its child nodes are represented)

In N8, which collects observations from Santa Clara, a very significant differentiation for tank types is observed in two nodes: N25 and N26. N25 includes "low tank", "other", artificial not destroyed" and "artificial destroyed" with the highest mean 161.958 (about 162 adult individuals per observation). N26 includes "elevated tank", "cistern", "natural reservoirs", "liquid waste" and "surveillance", with a standard deviation of 6.542, much lower than N25 (Figure 9).

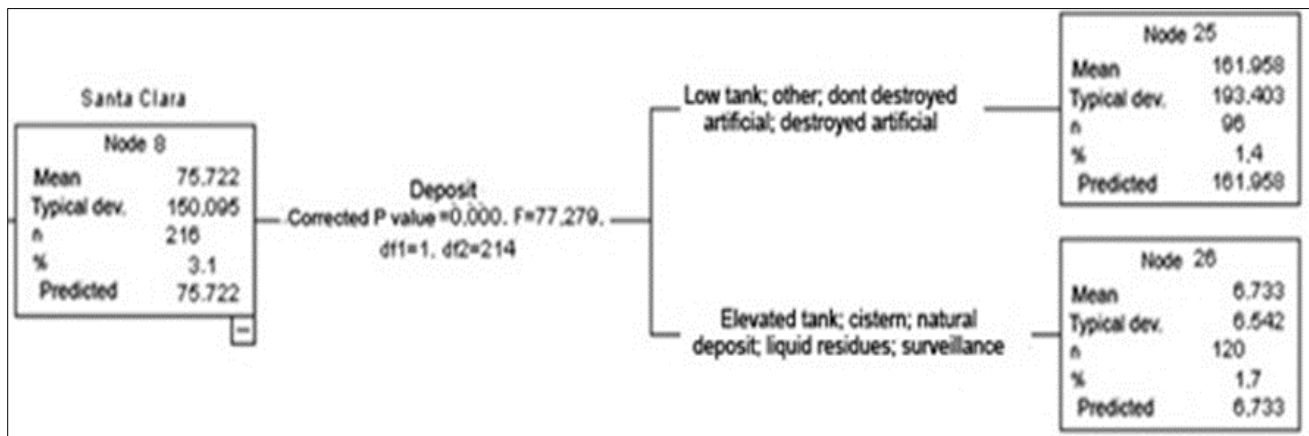

**Figure 9** Third level of the decision tree for the 2017-2018 period (only N8 and its child nodes are represented)

From N9 onwards, the formation of 4 nodes N27, N28, N29 and N30 is observed, which classifies the types of tanks into four groups. The one with the highest mean is N27 corresponding to "low tank" with a value of 4.608 and is followed by "other" with a mean of 2.200, the rest of the deposit types corresponding to N29 and N30 present a mean below one individual per observation (Figure 10).

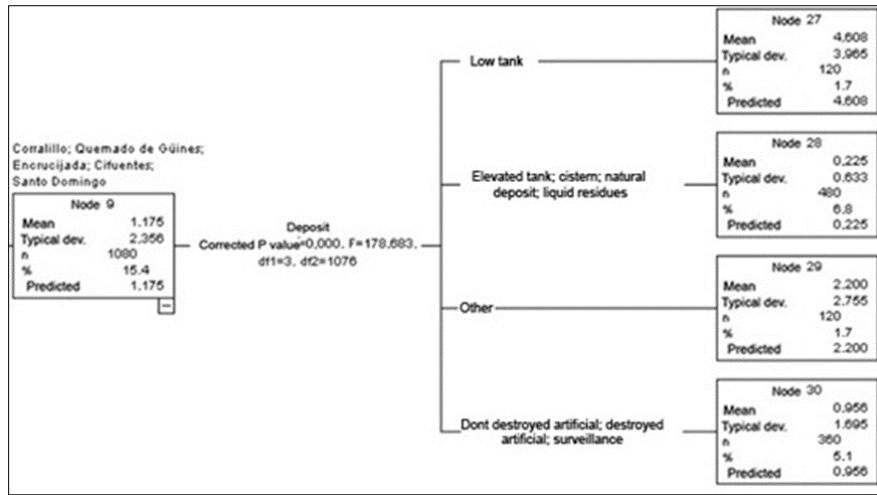

Figure 10 Third level of the decision tree for the 2019-2020 period (only N9 and its child nodes are represented)

In N10, the variability is very large resulting in a classification of 9 deposit types studied in six groups, ranging from N31 to N36. The deposit type with the highest mean value was "low tank", with a value of 33.863; in descending order followed by "other", with mean of 16.286; "artificial not destroyed", with mean of 3.994; "cistern" and "surveillance", with 2.036 and finally "elevated tank", natural deposits and "liquid waste", with less than one individual per observation (0.813) (Figure 11).

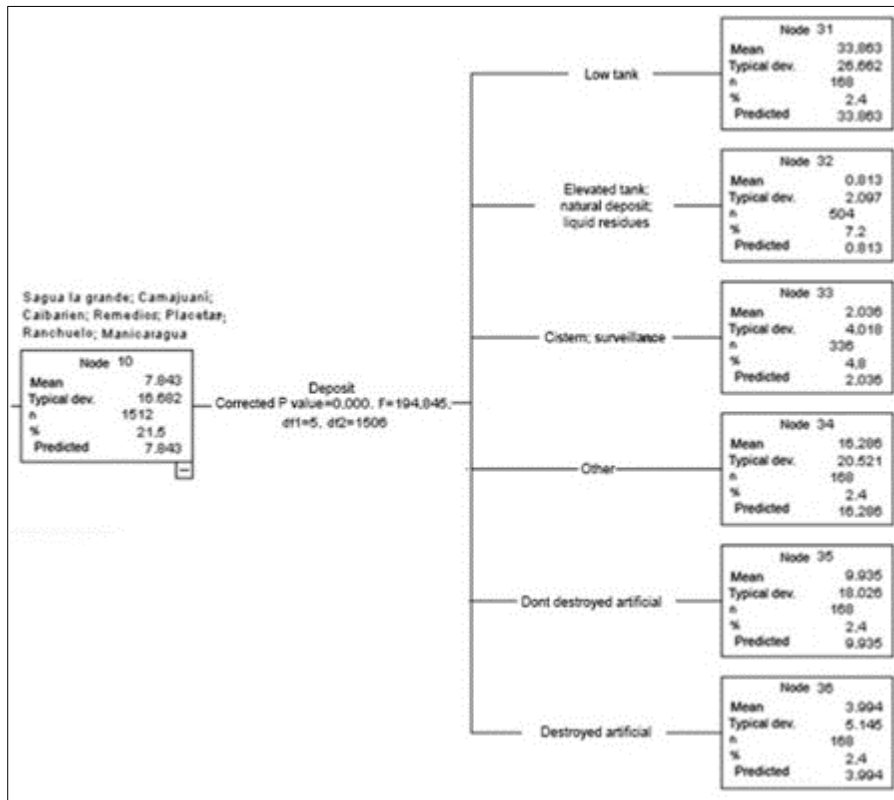
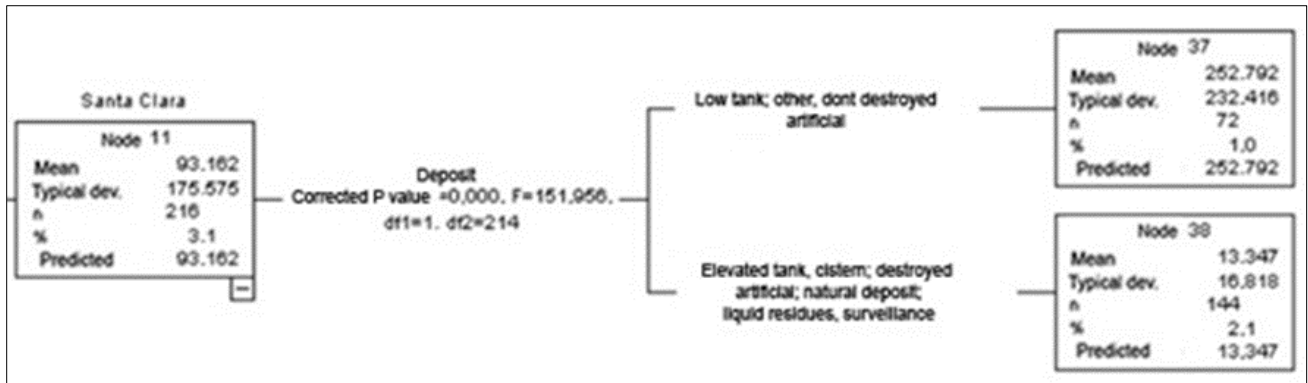

Figure 11 Third level of the decision tree for the period corresponding to 2019-2020 (only N10 and its child nodes are represented)

In N11, only Santa Clara is included and the differentiation by tank type results in two groups N37 and N38. In N37 ("low tank", "other" and "artificial not destroyed"), the mean is 252.792; about 253 individuals per observation, very high with respect to N38 ("elevated tank", "cistern", "artificial destroyed", natural deposits", liquid waste" and "surveillance") with mean of 13.347 (Figure 12).



**Figure 12** Third level of the decision tree for the period corresponding to 2019-2020 (only N11 and its child nodes are represented)

In summary, the table 1 shows a grayscale differentiation of the means of adult individuals by type of deposit, considering the three periods determined by the first predictor variable (year) and the second predictor variable (municipality). For the differentiation of the shades, an exponential function of base 10 ( $y=10^x$ ) was used, so that as the exponent increases, the coloration becomes darker.

**Table 1** Means of adult individuals per observation for the third level of the decision tree

		N1: Year 2016		N2: Year 2017 y 2018			N3: Year 2019 y 2020			
		Municipality								
		N4		N5	N6	N7	N8	N9	N10	N11
Kind of deposits	TB	N12: 10.6		N15: 4.3	N21: 28.4	N25: 162	N27: 4.6	N31: 33.7	N37: 252.8	
	TE	N13: 0.67		N16: 0.1	N22: 2.3	N26: 6.7	N28: 0.2	N32: 0,8	N38: 13.3	
	C			N17: 0.3				N33: 2.0		
	DN			N16: 0.1	N24: 0.6			N32: 0.8		
	RL	N14: 2.5		N18: 2.5	N23: 8.6	N25: 162	N29: 2.2	N34: 16.3	N37: 252.8	
	Otro			N19: 0.8				N35: 9.9		
	AND			N20: 1.7	N:22: 2.3			N26: 6.7	N30: 0.97	N36: 4.0
	AD							N33: 2.0		
	V									

Legend: Mean number of adult individuals per observation is greater than zero and less than one; The mean number of adult exemplars per observation is greater than 1 and less than 10; The mean number of adult exemplars per observation is greater than 10 and less than 100; The mean number of adult exemplars per observation is greater than 100.

From the table above it is observed that the highest averages of individuals per observation are given for N37, which corresponds to "low tank", "Other" and "artificial not destroyed" in the municipality Santa Clara, between the years 2019 and 2020. In descending order, it is followed by N25, which corresponds to "low tank", "Other", "artificial not destroyed" and "artificial destroyed" also in the municipality Santa Clara, between the years 2017 and 2018.

In the same order N5 corresponding to the municipality Santa Clara in 2016, presents an average of 40.8 individuals per observation, although in this case there is no differentiation between the types of tanks, which is given because the division of a node can only occur in the child nodes where more than 50 observations can be included.

Given this limitation, figure 13 was produced, which shows the types of deposits for the Santa Clara municipality in 2016. The graph shows that the highest number of individuals per observation occur in "low tank", and in descending order followed by "other", "artificial not destroyed" and "artificial destroyed", however, the maximum of each of them is below the median for "low tank", the rest of the deposit types, the maximum value is well below the first quartile for "low tank".

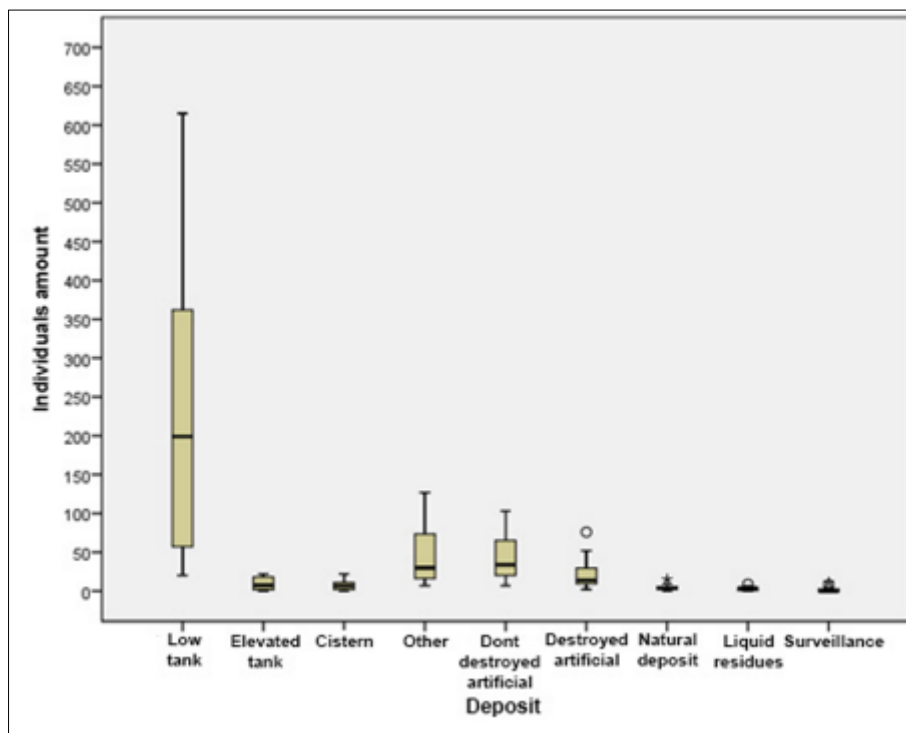

**Figure 13** Distribution of deposits by type for the municipality Santa Clara in 2016

In summary, *Ae. aegypti* was identified in the 13 municipalities of Villa Clara province, with a marked presence, both inside the home and in the surroundings/peridomicile, with a predominant focus on low tanks. The variables with the greatest influence in the investigation were: year, municipality and type of tank, while the month variable was excluded from the study, since its contribution to the final model was not significant.

#### 4. Discussion

The results obtained in the research in relation to the analysis by municipalities (2016-2020) according to the nodes, agree with those reached by Machado (2019) [33] in his master's thesis, where it was obtained, that both the highest mean value and the standard deviation were higher in Santa Clara and lower, in the municipality Encrucijada. In the lengths of the series (11 years of annual data), the maximum value reached was 8 778 in Santa Clara and the minimum, zero, for the municipalities: Corralillo, Quemado, Encrucijada and Caibarién, results that agree with those obtained by other authors in this regard [34-38] and even for other mosquito genera.

There is a large variability of data by municipality, which may be given by: the incidence of the particular physical-geographical characteristics of each of them, aspects inherent to the quality, capacity and preparation of the technical force dedicated to surveillance and vector control activities, as well as the stability of this qualified force, which does not behave in the same way in all territories, taking into account their socio-political, economic and cultural characteristics; especially in the municipality of Santa Clara, where there is a marked instability, which leads to fluctuations in the force and not always recruiting those with the necessary skills to ensure the quality of the actions; In addition, other aspects that intervene are the deficient individual support of the community in the protection and care of their health, focused on the low perception of risk manifested, the failure to perform the family autofocal every seven days, as well as the deficient water supply, the poor physical condition and protection of the tanks used for the storage of this water and the deficient environmental conditions, all of which agrees with the results achieved by other authors [26,33,34,37,39,40].

The results obtained in this research also coincide to a large extent with the behavior of the focal point in the 13 municipalities of Villa Clara province during the years 2007 to 2009, in the thesis of Machado (2019) [33], where it can be seen that the municipalities of Santa Clara, Ranchuelo, Placetas, Manicaragua, Santo Domingo and Sagua la Grande turned out to be those with the highest absolute frequency (Fi), something very similar for the case of cumulative relative frequency (fai), with slight changes in relation to the position of the municipalities, Santo Domingo and Sagua la Grande turned out to be those with the highest absolute frequency (Fi), something very similar for the case of the accumulated relative frequency (fai), with slight changes in relation to the position of the municipalities, with highlights for the municipalities of Manicaragua and Santo Domingo, something very similar to that obtained by other authors in this regard [33,38,41].

Similarly, the behavior of the province's focal point during the years 2010 to 2017 (eight years), where the municipalities with the highest absolute frequency (Fi), coincide with what was described in the preceding years, highlighting that the municipality of Santa Clara occupies in the eight years of study the most significant place, since all these years it is presented as the one with the highest focal point reported in the province, followed by Sagua la Grande, which is shown as the second highest focal point in 5 years (2011-2014-2015-2016 and 2017), the 3rd in 2 years (2010-2013) and the 5th one year (2012), followed by the municipality Ranchuelo, which was presented in the years studied as the second with the second highest reported focal points in one year (2010), the third in three years (2011-2016-2017), the fourth in three years (2012-2014-2015), and the fifth in two years (2013-2016). Manicaragua comes in second for two years (2012-2013), 4th for two years (2011-2016) and 5th for two years (2014-2017). In the case of the municipality of Santo Domingo, it is presented as third for three years (2012-2014-2015), 4th one year (2013) and 5th one year (2010), while the municipality of Placetas is presented as 4th for two years (2010-2011) and 5th in two years of those evaluated (2014-2017), which confirms that these municipalities are those that have maintained the entomological situation of the province compromised during the period evaluated and with this the epidemiological risk, something very similar to what was obtained in the current research, only with slight differences in some years.

We can evaluate that the stage of the years where the increase of cases and the focus on *Ae. aegypti*, is the time in our country when there is an increase in rainfall, high temperatures, variation in atmospheric pressure values, as well as the time of development of major atmospheric phenomena in the Caribbean Sea region, where our archipelago is geographically located, It is also the time of the year when, due to the beginning of the summer season in our country, the labor indiscipline of the work force in the system increases, which also has an impact on the increased risk in the proliferation of vector populations and thus the appearance of suspected cases, results that are consistent with those obtained by other authors [38,40,41,47].

The report of suspected cases of dengue manifests a proportional correspondence to the increase in focality by months in the municipality Santa Clara reporting an increase in the months of July to October, which demonstrates the existing relationship between the entomological and epidemiological aspects (focality-suspected cases). In addition, it is important to refer, as previously stated, that these months coincide with the time of increased rainfall, high temperatures and other variations in the status of the climate in our country, which also shows the interrelationship between these processes, results that agree with those obtained by other authors in this regard [42-45].

Regarding the third level of the tree, the predictor variable was the type of tank, in 2016, N4: it gave rise to three nodes N12, N13 and N14, differentiating the types of tanks into three groups, where the highest value of the mean (10.562) corresponded to the low tank, which is located in N12. The municipality of Santa Clara (N5) does not present divisions, this is because the possible divisions resulted in nodes with  $n < 50$ , which is restricted by the assumed model, but something very similar occurred in the rest of the years (2017-2020), since the low tank maintained predominance, corroborated by the values of the mean, a result that coincides with those obtained by other authors in this regard, and even in other provinces of Cuba [8, 38, 41].

The great variety in terms of the number of nodes obtained, evidences that there are large differences in relation to the number of adult individuals according to the type of reservoir, where the type of reservoir whose mean number of individuals per observation was higher, also turned out to be, the "low tank", with a value of 4, 297, followed by the type labeled with "other", with a mean of 2,521 and the rest with means below 1 (years 2017 and 2018), which agrees with results obtained by Diéguez et al. (2015) [8] and Fimia et al. (2020b) [47].

The differentiation in terms of deposits was similarly marked for the Santa Clara municipality (N8, a very significant differentiation is observed for tank types in two nodes: N25 and N26). N25 includes "low tank", "other", "artificial not destroyed" and "artificial destroyed", with the highest mean 161.958 (about 162 adult individuals per observation), where "elevated tank", "cistern", "natural deposits", "liquid waste" and "surveillance" are also included, with a mean of 6.542, much lower than N25, but with a marked predominance of low tank [8, 38, 41, 47]. So the highest averages of

individuals per observation occur for N37, which corresponds to "low tank", "Other" and "artificial not destroyed" in Santa Clara municipality, between the years 2019 and 2020. In descending order, it is followed by N25, which corresponds to "low tank", "Other", "artificial not destroyed" and "artificial destroyed" also in the municipality Santa Clara, between the years 2017 and 2018. In the same order N5 corresponding to the Santa Clara municipality in 2016, presents an average of 40.8 individuals per observation, although in this case there is no differentiation between tank types [8, 33, 46].

---

## 5. Conclusion

The variables with the greatest influence on population dynamics were: municipality and type of deposit, corroborating once again the correspondence between ecology and habitat of the species under analysis. The methodology used for the statistical technique of the decision tree provides excellent classification possibilities, with multiple observations based on the influence of the dependent variables. *Ae. aegypti* was identified in the 13 municipalities of Villa Clara province, with a marked presence, both inside the home and in the surroundings/peridomicile, being predominant the focus on the low tanks, which demonstrates the capacity of adaptation and ecological plasticity of the species in question, before the strong actions of chemical control to which the species has been subjected in our country since the 80's of the last century.

---

## Compliance with ethical standards

### *Acknowledgments*

The author would like to thank all those who have helped the author in this research, but especially to Prof. David Del Valle Laveaga, MSc. for his financial contribution to defray the costs of processing the article.

### *Disclosure of conflict of interest*

The authors declare that there is no conflict of interest regarding the publication of this article.

### *Statement of informed consent*

Informed consent was obtained from all individual participants included in the study.

### *Source of funding*

The authors declare that they have no funding support for this study.

---

## References

- [1] Marquetti FM. Bioecological aspects of importance for the control of *Aedes aegypti* and other culicidae in the urban ecosystem [doctoral thesis]. Havana City. Pedro Kourí" Institute of Tropical Medicine (IPK). 2006.
- [2] Guzmán MG, Álvarez M, Halstead SB. Secondary infection as a risk factor for dengue haemorrhagic fever/dengue shock syndrome: an historical perspective and role of antibody-dependent enhancement of infection. *Arch Virol.* 2013; 158: 1445-1459.
- [3] Cabezas SC, Fiestas DV, García MM, Palomino SM, Mamani CE, Donaires AF. Dengue in Peru: a quarter of a century after its reemergence. *Rev Peruana Med Exp Public Health.* 2015; 66(2): 219-227.
- [4] Gould E, Pettersson J, Higgs S, Charrel R, de Lamballerie X. Emerging arboviruses: why today? *One Health.* 2017; 4: 1-13.
- [5] Fimia DR, Marquetti FM, Iannacone J, Hernández CN, González MG, Poso del Sol M, Cruz RG. Anthropogenic and environmental factors on culicid fauna (*Diptera: Culicidae*) of Sancti Spiritus province, Cuba. *The Biologist (Lima).* 2015; 13(1): 53-74.
- [6] Pérez BMO. Role of *Aedes* mosquitoes in pathogen transmission. *AMC.* 2018; 22(5): 634-639.
- [7] Edwards HM, Chin VD, Duy BL, Thanh PV, Thang ND, Trang DM, Chavez I, Hii J. Characterising residual malaria transmission in forested areas with low coverage of core vector control in central Vietnam. *Paras Vect.* 2019; 12: 454.

- [8] Diéguez FL, García JA, San Martín MJL, Fimia DR, Iannacone OJ, Alarcón-Elbal PM. Seasonal behavior and relevance of permanent and useful reservoirs for the presence of *Aedes (Stegomyia) aegypti* in Camagüey, Cuba. *Neotropical Helminthology*. 2015; 9(1): 103-111.
- [9] Wilke ABB, Medeiros-Sousa AR, Ceretti-Junior W, Marrelli MT. Mosquito populations dynamics associated with climate variations. *Acta Tropica*. 2016; 166: 343-350.
- [10] Borge de Prada M, Rodríguez-Sosa MA, Vásquez Bautista YE., Guerrero KA, Alarcón-Elbal PM. Mosquitoes (Diptera, Culicidae) of medical importance associated with urban solid waste in Jarabacoa, Dominican Republic. *Revista Salud Jalisco, Número Especial*. 2018; 20-27.
- [11] Fimia DR, Díaz ZM, Ramos RQ, Reid JW, Santander CE, Victores IS. On experimental predation of mosquito larvae by the copepod *Mesocyclops aspericornis* (Copepoda: Cyclopoida). *REDVET*. 2010; 11(38): 1- 7.
- [12] Fimia DR, Aldaz CJ, Aldaz CN, Segura OJ, Segura OJ, Cepero RO, Osés RR, Cruz CL. Mosquitoes (*Diptera: Culicidae*) and their control by means of biological agents in Villa Clara province, Cuba. *International Journal of Current Research*. 2016; 8(12): 43114-43120.
- [13] Alarcón EPM, Paulino RR, Diéguez FL, Fimia DR, Guerrero KA, González M. Mosquito-borne arbovirosis (Diptera: Culicidae) in the Dominican Republic: a review. *The Biologist*. 2017; 15(1): 193-219.
- [14] Benítez PMO. Role of *Aedes* mosquitoes in pathogen transmission. *AMC*. 2018; 22(5): 634-639.
- [15] González BR. Description of a new species of *Culex* (Diptera: Culicidae) from Cuba. *Bulletin of the Aragonese Entomological Society (SEA)*. 2013; (52): 117-8.
- [16] Nguyen TT, Lundkvist A, Lindahl J. Urban transmission of mosquito-borne flaviviruses – a review of the risk for humans in Vietnam. *Infect. Ecol. Epidemiol*. 2019; 9: 1660129.
- [17] Ayala SY, Colos GP, Portal QE, Ibarra JL, Condor AR, Carrasco BC, Ramírez R. Quantitative biological response of two predators (Heteroptera: Notonectidae) in larval control of *Aedes aegypti* (Diptera: Culicidae). *Revista Colombiana de Entomología*. 2021; 47(2): e10535.
- [18] Rydzanicz K, Czulowska A, Dyczko D, Kiewra D. Assessment of mosquito larvae (Diptera: Culicidae) productivity in urban cemeteries in Wrocław (SW Poland). *International Journal of Tropical Insect Science*. 2021; 1-7.
- [19] González BR. *Culicidae of Cuba*. 1<sup>st</sup> ed. Havana: Scientific-Technical Editorial. 2006.
- [20] Brathwaite DO, San Martín JI, Montoya RH, Del Diego J, Zambrano B, Dayan GH. The history of dengue outbreaks in the Americas. *The American Journal of Tropical Medicine and Hygiene*. 2012; 87(4): 584-593.
- [21] World Health Organization (WHO). *State of the Art in the Prevention and Control of Dengue in the Americas*. Meeting Report. Washington, DC. 2014.
- [22] World Health Organization (WHO). *Zoonoses and Veterinary Public Health. Emerging zoonoses*. 2016.
- [23] Bhatt S, Gething P, Brady O. The global distribution and burden of dengue. *Nature*. 2013; 37(6): 1103-16.
- [24] Cauchemez S, Ledrans C, Poletto P, Quenel H, Valk V, Colizza P, Boelle Y. Local and regional spread of chikungunya fever in the Americas. *Euro. Surveill*. 2014 ; 19: 20854.
- [25] Bezerra JMT, Araújo RGP, Melo FF, Gonçalves CM, Chaves BA, Silva BM, Silva LD, Brandão ST, Secundino NFC, Norris DE, Pimenta PFP. *Aedes (Stegomyia) albopictus* dynamics influenced by spatio temporal characteristics in a Brazilian dengue-endemic risk city. *Acta Tropica*. 2016; 164: 431-437.
- [26] Riverón CRL. Emerging and reemerging diseases: a challenge for the 21<sup>st</sup> century. *Rev Cubana Pediatrics*. 2002; 74(1): 7-22.
- [27] Gould E, Higgs S. Impact of climate change and other factors on emerging arbovirus diseases. *Transactions of the Royal Society of Tropical Medicine and Hygiene*. 2009; 103(2): 109-121.
- [28] Rivera GO. *Aedes aegypti*, dengue virus, chikungunya, Zika and climate change. Maximum medical and official alert. *REDVET*. 2014; 15(10).
- [29] Zanluca C, Melo VC, Mosimann AL, Santos GI, Santos CN, Luz K. First report of autochthonous transmission of Zika virus in Brazil. *Mem Inst Oswaldo Cruz*. 2015; 110: 569-572.
- [30] Ministerio de Salud Pública (MINSAP). First case of Zika virus imported into Cuba. 2016a.
- [31] Ministerio de Salud Pública (MINSAP). First case of autochthonous Zika transmission in Cuba. 2016b.

- [32] Fimia DR, González GR, Cepero RR, Valdés ÁM, Osés RR, Corona SE, Argota PG. Influence of some climatic variables on the fluvial malacofauna with zoonotic importance in Villa Clara province. REDVET. 2012a; 13(7): 1695-7504.
- [33] Machado VI. Mathematical modeling of the population dynamics of the *Aedes aegypti* mosquito (Diptera: Culicidae) with some meteorological variables in Villa Clara province. 2007-2017 [master thesis]. ResearchGate. 2019.
- [34] Rodríguez MJ, Cepero RO, Rodríguez A. Surveillance and control of temporary and permanent breeding sites of culicidae in Villa Clara. REDVET. 2006; 7(7): 12-6.
- [35] Osés RR, Fimia DR, Iannacone OJ, Saura GG, Gómez CL, Ruiz CN. Modeling of the equivalent effective temperature for the Yabu season and for the total larval density of mosquitoes in Caibarién, Villa Clara province, Cuba. Rev Peruana de Entomología. 2016; 51(1): 1-7.
- [36] Osés RR, Fimia DR, Marinice P, Castillo CJC, Pedraza MA, Cepero RO, Pérez de Corcho MM. Modeling of total larval and *Anopheles* mosquito density in Villa Clara, Cuba. Impact of atmospheric pressure. REDVET. 2018; 19(6).
- [37] Fimia DR, Machado VI, Osés RR, Aldaz CJW, Armiñana GR, Castañeda LW, Argota PG, Hernández CL, Iannacone J. Mathematical modeling of the population dynamics of the *Aedes aegypti* mosquito (Diptera: Culicidae) with some climatic variables in Villa Clara, Cuba. 2007- 2017. The Biologist (Lima), vol.17, jul-dic, Suplemento Especial. 2019; 2.
- [38] Fimia DR. Mathematical modeling of population dynamics of the *Aedes aegypti* (Diptera: Culicidae) mosquito with some climatic variables in Villa Clara, Cuba. International Journal of Zoology and Animal Biology (IZAB). 2020; 3(3).
- [39] Valdés MV, Reyes AM, Marquetti FMC, González BR. Mosquito species richness, distribution and breeding sites in Boyeros municipality. Rev Cubana Med Trop. 2013; 65(1): 131-136.
- [40] Rodríguez RM, Díaz RM, Álvarez GY, Calderón AO. Breeding sites of *Aedes aegypti* (Linnaeus) and geographic distribution of *Aedes albopictus* (Skuse) in the province of Limón, Costa Rica. 2012. Rev Cubana Med Trop. 2014; 66(2): 219-227.
- [41] Machado VI, Hernández CL, Fimia DR, Pérez TBE, Santana RM, Molina PA, Quintero SN. The resident focal point: an alternative in the control of *Aedes aegypti* (Diptera: Culicidae) and the prevention of dengue in a health area of Santa Clara municipality, Villa Clara, Cuba. REDVET. 2018; 19(6): 1-7.
- [42] Ayala SYO, Ibarra JI, Grieco JP, Achee N, Mercado HR, Fernández SI. Behavioral response of *Aedes aegypti* (Linnaeus, 1762) to pyrethroid adulticides commonly used in public health. Peruvian Journal of Experimental Medicine and Public Health. 2008; 25(1): 26-34.
- [43] Fimia DR, Osés RR, Otero MM, Diéguez FL, Cepero RO, González GR, Silveira PEA, Corona SE. The control of mosquitoes (Diptera: Culicidae) using biomathematical methods in Villa Clara province. REDVET. 2012b; 13(3).
- [44] García GS, Pérez BA, Fimia DR, Osés RR, Garín LG, González GR. Influence of some climatological variables on larval densities in culicidae hatcheries. Pol Cap. Roberto Fleites 2009-2010. REDVET 13(05B).2012.
- [45] Ngoagouni C, Kamgang B, Nakouné E, Paupy C, Kazanji M. Invasion of *Aedes albopictus* (Diptera: Culicidae) into central Africa: what consequences for emerging diseases? Parasites & Vectors. 2015; 8: 191-7.
- [46] Troyo A, Calderón AO, Fuller DO, Solano ME, Avedaño A, Arheart KL. Seasonal profiles of *Aedes aegypti* (Diptera: Culicidae) larval habitats in an urban area of Costa Rica with a history of mosquito control. J Vector Ecology. 2008; 33(1): 76-88.
- [47] Fimia DR, Osés RR, Alarcón EPM, Aldaz CJW, Roig BB, de la Fé RPY. Mathematical modeling of the effect of atmospheric pressure on the population density of mosquitoes (Diptera: Culicidae) in Villa Clara, Cuba. Journal of the School of Medicine (Rev. Fac. Med.). 2020; 68(4): 541-549.