

# PCW/PHEOS-WCA: Quasi-geostationary Arctic measurements for weather, climate and air quality from highly eccentric orbits

Richard L. Lachance<sup>1</sup>, John C. McConnell<sup>2</sup>; C. Tom McElroy<sup>2</sup>; Norm O'Neill<sup>3</sup>; Ray Nassar<sup>4</sup>; Henry Buijs<sup>1</sup>; Peyman Rahnama<sup>5</sup>; Kaley Walker<sup>6</sup>; Randall Martin<sup>7</sup>; Chris Sioris<sup>2</sup>; Louis Garand<sup>4</sup>; Alexander Trichtchenko<sup>4</sup>; Martin Bergeron<sup>8</sup>; and the PHEMOS Science Team<sup>9</sup>

<sup>1</sup>ABB Analytical, Canada; <sup>2</sup>York University, Canada; <sup>3</sup>U of Sherbrooke, Canada; <sup>4</sup>Environment Canada, Canada; <sup>5</sup>COM DEV, Canada; <sup>6</sup>U of Toronto, Canada; <sup>7</sup>Dalhousie University, Canada; <sup>8</sup>Canadian Space Agency, Canada; <sup>9</sup>(see Acknowledgements), Canada

## ABSTRACT

The PCW (Polar Communications and Weather) mission is a dual satellite mission with each satellite in a highly eccentric orbit with apogee ~42,000 km and a period (to be decided) in the 12–24 hour range to deliver continuous communications and meteorological data over the Arctic and environs. Such as satellite duo can give 24×7 coverage over the Arctic. The operational meteorological instrument is a 21-channel spectral imager similar to the Advanced Baseline Imager (ABI). The PHEOS-WCA (weather, climate and air quality) mission is intended as an atmospheric science complement to the operational PCW mission. The target PHEOS-WCA instrument package considered optimal to meet the full suite of science team objectives consists of FTS and UVS imaging sounders with viewing range of ~4.5° or a Field of Regard (FoR) ~ 3400×3400 km<sup>2</sup> from near apogee. The goal for the spatial resolution at apogee of each imaging sounder is 10×10 km<sup>2</sup> or better and the goal for the image repeat time is targeted at ~2 hours or better. The FTS has 4 bands that span the MIR and NIR with a spectral resolution of 0.25 cm<sup>-1</sup>. They should provide vertical tropospheric profiles of temperature and water vapour in addition to partial columns of many other gases of interest for air quality. The two NIR bands target columns of CO<sub>2</sub>, CH<sub>4</sub> and aerosol optical depth (OD). The UVS is an imaging spectrometer that covers the spectral range of 280–650 nm with 0.9 nm resolution and targets the tropospheric column densities of O<sub>3</sub> and NO<sub>2</sub> and several other Air Quality (AQ) gases as well the Aerosol Index (AI).

**Keywords:** Geostationary Viewing, FTS MIR-NIR Imager, UVS Imager, GHG, air quality, weather forecasting, boreal forest burning, aerosols.

## 1. INTRODUCTION

The Canadian Space Agency, in partnership with Environment Canada and the Department of National Defense and several other government ministries, is planning an innovative operational mission called PCW (Polar Communications and Weather) that will combine communications and meteorology over the Arctic region. This mission will provide high capacity, continuous communication services over the Canadian Arctic as well as meteorological observations which will lead to improved weather forecasting for the Arctic region. The PCW mission includes an imaging spectro-radiometer (PCW/ISR) much like the MODIS or ABI imagers. It is planned to have ~21 channels overlapping with standard meteorological imaging channels to cover the visible, NIR and MIR. The goal for the spatial resolution of the shortest wavelength visible channel is ~0.5×0.5 km<sup>2</sup>. The communications and meteorological goals of 24×7 coverage will be achieved using 2 satellites flying in tandem in a highly elliptical orbit (HEO) with an apogee ~42,000 km and an orbital period to be chosen between 12 and 24 hours (see Figure 1 left). To date, the 3 orbital periods considered are the 12 hour, or Molniya orbit, the 16 hour Three Apogee Orbit (TAP) and a 24 hour or Tundra orbit. The Molniya orbit is better for Earth observations since it has a lower apogee. However, it crosses the Van Allen belts 4 times a day and with its perigee ~500 km where the instruments are subjected to more intense high energy proton and electron radiation than for a TAP orbit with a much higher perigee. The TAP orbit [1] is the most likely candidate and has a lower apogee than the modified Tundra orbit (24 hour period, inclination > 80°). The nadir location of the orbit in an Earth-based frame is shown at right in Figure 1. Both the TAP and Tundra orbits have reduced radiation hazards as compared with the Molniya orbit as their perigees are higher. The PCW/ISR is designed to image the entire planetary hemisphere under the spacecraft from several hours before and after apogee, the exact time depending on the orbit chosen. This should provide meteorological observations 24 h/day, 7 days/week of entire northern latitudes with high temporal resolution (of the order of 15 minutes) at MIR wavelengths and reduced coverage in the solar reflected light channels during the Arctic winter. This should provide more timely weather advisories and, more specifically, information about tropospheric winds using cloud images.

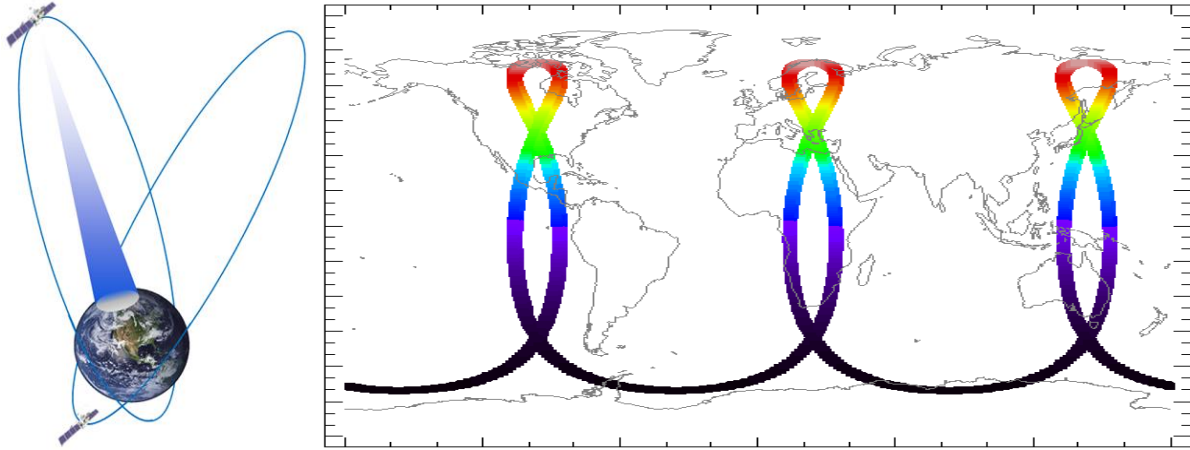

Figure 1: The ground track for a satellite in a Three Apogee (TAP) Orbit during a 48-hour period. The color scale indicates the satellite altitude from a perigee of 8100 km (black) to an apogee of 43,000 km (red). A second satellite in the same TAP orbital plane, would have an identical ground track, offset by 8 hours [1].

## 2. POLAR HIGHLY ELLIPTICAL ORBITAL SCIENCE: WEATHER, CLIMATE AND AIR QUALITY

The PHEOS (Polar Highly Elliptical Orbital Science) Weather, Climate and Air Quality instrument suite and science mission would be an essential complement to the PCW meteorological mission. The proposed instruments will enhance the PCW meteorological mission by adding imaging vertical sounding measurements to the suite of meteorological information gathered by the PCW meteorological imager. The basic instruments are a Fourier transform spectrometer (FTS) operating in the Near-IR (NIR) and Mid-IR (MIR) and a dispersive UV-VIS (ultraviolet-visible) spectrometer (UVS). The FTS will allow measurement of temperature and water vapour vertical profiles and a number of other species essential for understanding and prediction of air quality in the Arctic and environs and monitoring changes in climate gases, while the UVS instrument will provide additional critical measurements on air quality. The idea of quasi-geostationary viewing allows observation of continuous change for the fields of interest under the satellite. For fields such as temperature and water vapour one can measure the evolution of the weather with height, thus allowing a better assessment of the ability of models to represent processes.

## 3. WEATHER, CLIMATE CHANGE AND AIR QUALITY MONITORING

Changes in the Arctic region, such as the rapid disappearance of multi-year ice [2], appear to be a harbinger of early climate change, and global temperature changes are amplified at polar latitudes by changes in surface albedo, water vapour amount and possibly changes in the Arctic Ocean currents. As temperatures increase and summer multi-year ice recedes, ice melts for longer periods, the ocean warms and there is more moisture in the air which can lead to reduced radiative cooling, increasing the potential for storm formation. Moreover, the increased radiative forcing also accelerates the melting of the ice.

### 3.1 Meteorological measurements

The Arctic region is a fundamental driver critical for the development of winter storms in boreal latitudes. And as all major forecast centres use global models to drive higher-resolution, regional forecasts, the PCW and PHEOS data set will be a major contribution to this international effort.

Studying climate change at high latitudes requires a better understanding of weather and climate processes, such as convection, ice formation and precipitation and interaction with the changing snow and ice surface in polar regions. PHEOS instruments will contribute to these improvements.

### 3.2 Greenhouse gas measurements

It is important to accurately monitor greenhouse gases (GHGs) in the atmosphere to understand and quantify their sources and sinks, and this is no less important in the Arctic and high latitudes. In fact, there are concerns that methane could be released in significant amounts from either warming permafrost or possible release from shallowly buried clathrates off the polar shelf [3]. The potential rapid release of Arctic methane would accelerate global warming around the world.

The potential increase in release of CO<sub>2</sub> from permafrost thaw or other manifestations of Arctic climate change is also an issue. Although in wetter permafrost regions, methane is the dominant GHG released, CO<sub>2</sub> dominates in drier regions and understanding the balance between emissions of these two GHGs in a changing Arctic will continue to be important [4].

The net CO<sub>2</sub> balance of boreal forests (between photosynthesis and respiration) is another topic of interest for scientific and policy reasons. Quasi-continuous PHEOS CO<sub>2</sub> observations over the Boreal forests would be valuable for studies of the CO<sub>2</sub> uptake and release from these forests.

Canadian and international groups will be able to use the PHEOS CO<sub>2</sub> and CH<sub>4</sub> data in concert with ground-based and aircraft data in data assimilation systems to better estimate GHG emission sources and sinks and improve our understanding of carbon cycle processes.

### 3.3 Arctic air quality

With the decrease in the polar multi-year ice the summer time, Arctic becomes much more accessible to shipping and also to mineral and gas exploration under the cold Arctic waters. Already large ships are making their way across the Arctic Ocean and this is likely to increase dramatically over the next 10–20 years [5]. As a result, one anticipates that the air quality of the north will degrade and there will be a need for continuous monitoring of many species related to air quality (see below). Some of the emissions expected from shipping and drilling will be volatile organic compounds and NO<sub>x</sub> and so, in sunlight, ozone, a GHG, will be generated adding to the radiative forcing in the Arctic. In addition, SO<sub>2</sub> and NO<sub>2</sub> and particulate levels are expected to increase during the summer shipping and exploration period compromising health of all Arctic inhabitants. Furthermore, with the potential drying of the boreal forest, it is anticipated that the number of incidents of air pollution from the burning of the boreal forest impacting the Arctic will increase and much of this pollution ends up in the Arctic.

## 4. INSTRUMENTS

In order to provide meteorological, climate, and air quality data to complement the PCW/ISR imager, instruments with an imaging capacity are essential. The CSA imposed rather strict limits on the total mass, power, and volume available for the PHEOS instrument package of 50 kg, 100 W and  $\sim(30\text{ cm})^3$ , respectively. These tight constraints impose strict limitations on telescope size, as well as on spectral and spatial resolution. One of the proposed innovations is to house the FTS and UVS within the same structure as shown in Figure 2 [6].

The scientific objectives as outlined in the User Requirement Document (URD), developed in Phase 0, call for an observation quality for species and temperature to be at least as good as currently available from a low Earth orbit (LEO) instrument such as the European Infrared Atmospheric Sounding Interferometer (IASI) flying on MetOp. Thus an FTS was chosen with spectral range 0.7 to 14  $\mu\text{m}$ , with 4 bands, 1, 2, 3 and 4, listed in Table 1. There are two MIR bands, namely Band-1 from 6.7 to 14.2  $\mu\text{m}$ , and Band-2 from 3.7 to 5.6  $\mu\text{m}$ , and two NIR bands, Band-3  $\sim 1.6\ \mu\text{m}$  and Band-4 at 0.76  $\mu\text{m}$ . The goal for the FTS spatial resolution is  $10\times 10\text{ km}^2$ . The spectral resolution is  $0.25\text{ cm}^{-1}$  for Bands 1 to 4, and  $0.5\text{ cm}^{-1}$  for Band-4. The sensitivity required is slightly better than the current version of IASI. It is anticipated that the FTS will image its FoR approximately once per hour (goal) with a threshold value of 3 hours. This will be done by using detectors with  $\sim 56\times 56$  pixels and by staring at the same ground spot for  $\sim 100$  seconds in order to achieve the S/N requirements. It is estimated that cloud movement in the image will not be a serious problem. The FTS then steps across the FoR. If it is necessary to reduce the data rate of the instrument, pixels will be selected for downlink in a “chessboard” pattern or with a simple algorithm based on the zero path-length transform signal to assess the degree of cloudiness. In addition, to imaging the FoR, a deep space calibration will be necessary. It will be made by pointing the instrument  $\sim 10^\circ$  from the centre of the FoR.

### UVS view

Ebox in red, covers not shown

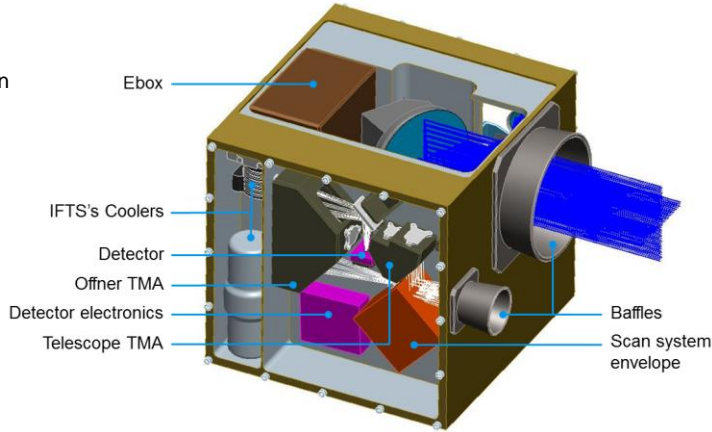

### IFTS view

Small Configuration, covers not shown

- Concept with electronics packaged with optics to reduce overall volume
- Electronics in separate boxes mounted in the spacecraft is better for thermal considerations
- Volume occupied by the electronics is 9600 cm<sup>3</sup>

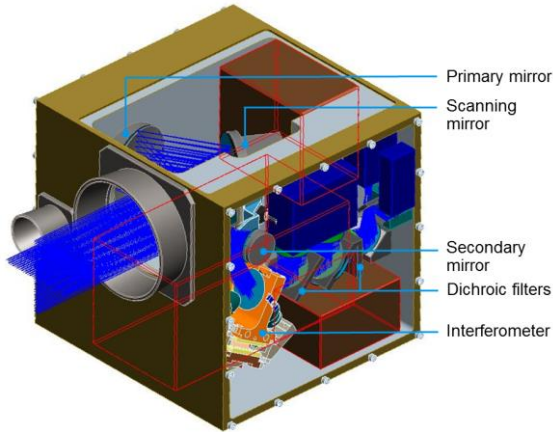

### IFTS

Opto-mechanical 3D layout

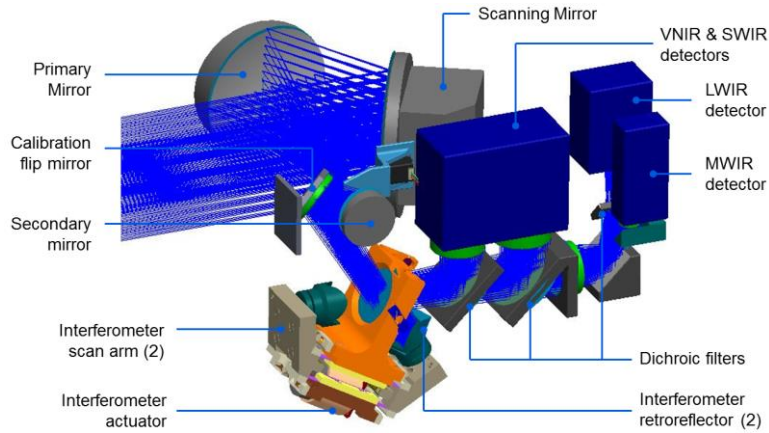

Figure 2: Preliminary design for the FTS/UVS instrument combination for PCW/PHEOS.

Table 1: FTS and UVS instrument bands

Instrument Band	Spectral Range	Spectral Resolution	Spatial Resolution
FTS 1	700–1500 cm <sup>-1</sup>	0.25 cm <sup>-1</sup>	10×10 km <sup>2</sup>
2	1800–2700 cm <sup>-1</sup>	0.25 cm <sup>-1</sup>	
3a	5990–6010 cm <sup>-1</sup>	0.25 cm <sup>-1</sup>	
3b	5990–6257 cm <sup>-1</sup>	0.25 cm <sup>-1</sup>	
4	13060–13168 cm <sup>-1</sup>	0.50 cm <sup>-1</sup>	
UVS	280–650 nm	1 nm	8×8 km <sup>2</sup>

The UVS instrument is a grating spectrometer with 1 nm spectral resolution (3 samples) in order to retrieve the target AQ gases listed in Table 2 (see below). The goal for the spatial resolution of the UVS instrument is  $\sim 8 \times 8 \text{ km}^2$ . The UVS instrument will only stare for a few seconds during which it will take many images of the same spot to satisfy detector constraints. The UVS instrument is described in more detail in [7] and also in [8]. The details of the UVS instrument design as well as related analyses and trade-off studies including those related to resolution, spectral coverage and sampling can also be found in [7].

It is anticipated that the FoR, an area  $\sim 3400 \times 3400 \text{ km}^2$  at apogee, will be imaged by both instruments. During the viewing period the spacecraft antenna will be pointing at the ground receiving station in Northern Canada and it is anticipated that for a TAP orbit that observations will be taken  $\pm 6$  hours of apogee which may be extended by an additional  $\pm 4$  hours under certain circumstances for possible stereo-viewing with both satellites. During the descent the spatial resolution will improve by about 30%. In addition, during this period the ground track of the space craft will move at  $< 300 \text{ m/s}$ .

## 5. VIEWING STRATEGY

A zero order viewing strategy is that the FoR for both PHEOS instruments will overlap with that of the PCW/ISR. However, for a significant part of the year the Arctic region will be in darkness and only the MIR channels of the PCW/ISR and the FTS can collect data if viewing is constrained to be towards the communications receiver. Thus it is planned to design viewing flexibility so that the UVS and FTS can target different locations away from the communications receiver. For simplicity, the imaging UVS and FTS have a fixed range of viewing angles and a fixed number of pixels within this range. It is planned to design flexibility into the viewing/scanning system so that special events can be tracked more rapidly with the PHEOS instruments but with reduced spatial coverage. It is anticipated that boreal forest fires, volcanic eruptions, extreme low pressure storms along the east coast of Canada and USA or regional air quality events will be targeted.

As stated earlier, the multiband imager will scan the full earth disk and hence provide the maximum arctic coverage in addition to extensive coverage at lower latitudes. On the other hand, the imaging UVS and FTS instruments have a limited FoR and hence will concentrate nominal viewing in the high arctic region.

## 6. COMPOSITION MEASUREMENTS

The species to be measured by the PHEOS instruments are important for weather (W), climate (C), and air quality (AQ) applications. The target species are listed in Table 2. Although the instruments for PCW/PHEOS are science (as opposed to operational) instruments, some of the anticipated products may be assimilated by weather forecast centres. In particular, it is anticipated that measurements of the tropospheric temperature and water vapour profiles using FTS measurements from Bands-1 and 2 will be important in improving Arctic weather information, and this could lead to more accurate forecasting of winter storms that break out from the Arctic. It is anticipated that the radiances will be assimilated by the forecast centres rather than retrieved profiles.

Table 2: Target species

	Data product	Vertical resolution	Precision, Column amount	Instruments
W	Water profile	2 km	10%	FTS (1,2)†
W	Temp.	2 km	1°C	FTS (1)
C	CH <sub>4</sub>	PC*	4%	FTS (1)
C	CH <sub>4</sub>	TC	4%	FTS (3)
C	CO <sub>2</sub>	PC	1%	FTS (1)
C	CO <sub>2</sub>	TC	1%	FTS (3)
C/AQ	AOD	5 km	0.03 15%	FTS (4)
C/AQ	Ozone	TC/SC	$0.8 \times 10^{19} - 3 \times 10^{19}$	UVS, FTS (2)
AQ	NO <sub>2</sub>	TC/SC	$10^{15} - 10^{16}$	UVS
AQ	CO	PC	$1.3 \times 10^{18}$	FTS (2)
C/AQ	AI	PC	0.03 15%	UVS

\*PC, TC, SC: partial, tropospheric and stratospheric columns respectively, AOD: Aerosol optical depth

† The numerals refer to the bands used.

In addition, the spectral range of the FTS will allow measurements of CO<sub>2</sub> and CH<sub>4</sub> columns in both the NIR and MIR. The NIR measurements will yield total columns of these GHGs, while the MIR kernels contain abundance information from the mid-troposphere. In order to be useful for source inversion, the assigned precision requirements for CO<sub>2</sub> and CH<sub>4</sub> are high. The NIR Band-3 of the FTS has been allocated for these measurements.

A critical support measurement for GHG retrievals is the O<sub>2</sub> A-band in the FTS Band-4. The resolution targeted (Table 1) will allow the retrieval of surface pressure for converting the GHG column densities to column-averaged mixing ratios (XCO<sub>2</sub> and XCH<sub>4</sub>), along with an assessment of the amount of aerosol or thin cirrus present.

Tropospheric AQ products are also targets for PHEOS and are also listed in Table 2. In this case it is anticipated that the vertical resolution will be ~5–10 km, so that in effect, vertical columns will be measured by the UVS instrument and partial columns by the MIR channels of the FTS. Also for NO<sub>2</sub> and ozone the stratospheric columns (SC) have generally larger amounts than the tropospheric columns and care must be taken to extract the SC with sufficient accuracy that the tropospheric column (TC) has useful accuracy, hopefully for assimilation in air quality models in the post-2018 era. In addition, to ozone and NO<sub>2</sub> as target species, we also intend to include CO as a target species in the MIR. Although the kernel is not optimised for full TC amounts, measurements of the MIR channel of MOPITT [9] and IASI [10] have shown that useful profile information can be extracted.

As noted above, aerosol information can be obtained from the O<sub>2</sub> A-band. But useful aerosol information can also be obtained from the UV AI [11], which yields information on the aerosol amount and aerosol location in the vertical.

Calculations have been undertaken in Phase A to assess the possibility of retrieving the height and aerosol optical depth (AOD) of a layer or plume, of cloud or from Biomass Burning (BB). Various factors affect the precision of the retrieved AOD and plume height from the O<sub>2</sub>-A band. Among these are the true plume height, and the true AOD and the aerosol type. The surface albedo is a minor factor since the A-band provides the ability to disentangle surface reflectance from aerosol scattering by virtue of the large absorption optical depths. Plume height can be retrieved to within 100 m even for slightly absorbing aerosol (single scattering albedo of 0.95) if the plume is at higher altitude (e.g. 8–10 km) and the aerosol optical depth is 0.5 and known a priori (as well as all other aerosol parameters such as plume thickness, single scattering albedo, and phase function). Aerosol optical depth can be retrieved to 1% for such cases as well. These retrieval results were based on FTS simulations with a spectral resolution of 0.6 m<sup>-1</sup> and a signal-to-noise ratio of 160. For lower or optically thinner plumes, the retrieval precision worsens significantly. There has never been a dual-satellite-system providing observations of the A-band at high spectral resolution. The upcoming PHEOS mission would provide a unique opportunity to test the potential of such measurements to retrieval aerosol optical depth, plume height and phase function simultaneously.

There are many more species in addition to those listed in Table 2 than can be obtained with the PHEOS instruments. These include in the UVS, BrO, HCHO, AI, (HCO)<sub>2</sub>, in the MIR HNO<sub>3</sub>, PAN, CH<sub>3</sub>OH, HCOOH, HCN, NH<sub>3</sub>, CH<sub>3</sub>COOH, and SO<sub>2</sub> is available in both the UVS and MIR while CH<sub>4</sub>, CO<sub>2</sub> can be measured in both MIR and NIR.

Some of these species will only be accessible by temporal and/or spatial averaging. Other species will only be available for special events such as, for example, a volcanic eruption where SO<sub>2</sub> was measured by IASI [12] using SO<sub>2</sub> bands at 4 and 7.3 μm, or as HCN emissions, for example, from forest fires species [13] or Arctic Spring ozone depletion events when marine boundary layer BrO in the Arctic becomes very abundant [14].

## 7. SYNERGY WITH THE METEOROLOGICAL IMAGER

There is a strong potential for an important synergy between the PCW/ISR and the PHEOS instruments. PCW/ISR has higher surface spatial resolution, and a more rapid repeat viewing period, but its spectral resolution is much lower and, as compared to the FTS in the mid-IR, there is almost no capacity for retrieval with concomitant vertical information. For example, the PCW/ISR aims to have column ozone amounts, but the product derived from both the UV and mid-IR instruments will have height information and promises to be more quantitative. One of the important uses of the imager using the highest spatial resolution visible channel is for cloud clearing (see below).

## 8. CLOUDINESS ISSUES

Cloudy pixels are an issue for both PHEOS instruments, although sometimes cloudiness can be turned to an advantage. For example, if the cloud top height is known, then the amount of material above that level is known, and if there is a nearby cloud-free pixel, then the differing amount of material lies beneath the cloud level. However, generally

cloudiness poses a problem if it is not 100% or less than some small number depending on the retrieval problem. To some extent, the spectral information in the MIR also contains useful cloud clearing information. However, it will also be useful to have the more detailed spatial information available from the PCW/ISR.

Nadir observations can be adversely affected by clouds in the field of view. Krijger *et al.* [15] studied the effect of sensor resolution on the number of cloud-free observations. However, if MIR channels such as at 14.5  $\mu\text{m}$  with a higher altitude weighting function ( $\sim 100$  hPa) are chosen, then much more temperature data becomes useful [16]. Also the European Centre for Medium-Range Weather Forecasts (ECMWF) is now using completely cloudy pixels [17]. Given the  $10 \times 10 \text{ km}^2$  ground pixel, approximately 18% of the pixels would be cloud-free globally, 21% would be at the 5% threshold and 26% would be at the 20% threshold. Given a  $3 \times 3 \text{ km}^2$  ground pixel, approximately 25% of the pixels would be cloud-free, 25% would be at 5% threshold and 27% would be at 20% threshold. As stated above, the PCW/ISR imager data would be used for selecting the cloud-free ground pixels.

## 9. AEROSOLS

The PCW/ISR has the potential for retrieving AOD much like MODIS but, as for MODIS, it will be difficult to get accurate absolute amounts in the case of the high surface reflectance and low sun angle conditions of the Arctic. However, the combination of the imager with the UV-Vis data and also the  $\text{O}_2$  A-band (Band-4) data can yield a more quantitative product. As well, in combination with other information such as ground-based sun photometer data as well as ground and satellite-based backscatter lidar data, the AOD retrievals can be improved over dark targets such as open water and developed over bright Arctic surfaces such as snow and ice. With the high spatial and temporal resolution of the PCW/ISR, there will be detailed information on the spatio-temporal evolution of plumes from biomass burning and dust storms pollution dispersion, dust and ash advection from volcanic events. Combined with species data from ground-based and satellite data, it will be possible to back out quantitative information on emission strengths, vertical profiles and the geographic positions for these aerosol sources.

## 10. CONCLUSIONS FROM PHASE-A

The PHEOS Phase A study was focused on the refinement of the URD (User Requirements Document) and the preparation of a Mission Requirements Documents (MRD) based on the URD. The instruments and the ground segment concepts of PHEOS-WCA were defined in a more detailed fashion. The requirements from the MRD were flowed-down into a preliminary system requirements document (PSRD) for the space segment and for the ground segment of PHEOS WCA.

### 10.1 Ground Segment

The data captured by PHEOS-WCA will follow two main streams: an operational stream to be included in the weather data assimilation to serve the daily needs of weather forecasting, and a science stream to provide data for research in atmospheric science as well as monitoring of Arctic air quality. The operational stream will also include data to monitor special events such as volcanic eruptions, severe storms and forest fires. The reception of the PHEOS-WCA data and the processing and management of the operational data stream will be performed by the Ground Segment of PCW. The Ground Segment of PHEOS-WCA will handle the processing, archiving and distribution of the science data stream. It will be supervised by the PHEOS-WCA Science Operation Centre (SOC). The SOC will also be in charge of coordination with the PCW Ground Segment, as well as of early orbit phase data validation and of outreach and education.

### 10.2 Instrument Design Status

Based on detailed design analysis, three instrument concepts were proposed at the end of Phase A (see Figure 3).

- C1 is a configuration which is compliant with the imposed mass and volume constraints and which includes a three-band version of the imaging infrared FTS with a small telescope aperture.
- C2 is a configuration which includes all four of the URD bands for the imaging FTS with a small telescope aperture and also includes an imaging UV-VIS spectrometer.
- C3 is the configuration which includes a four-band imaging FTS with a large aperture telescope and an imaging UV-VIS spectrometer.



As noted, C1 complies with the very tight resource allocations imposed by the CSA. It complies with all threshold sensitivity requirements for the channels chosen for the FTS and addresses all the higher priority objectives outlined in the URD. In addition, we have chosen to maintain the goal of  $10 \times 10 \text{ km}^2$  spatial resolution rather than relax to the threshold of  $20 \times 20 \text{ km}^2$ . However, in most other cases the goals are not attained.

Configuration C2 complies with the threshold sensitivity requirements and covers all the science objectives but exceeds the linear dimensions allocation by 2 cm.

C3, the optimal configuration, complies with all goal sensitivity requirements, covers all the science objectives but exceeds the mass and the linear dimensions allocation by 16 kg and 23 cm respectively. Once the actual allocations are better known, it will be possible to make a trade between the required resources and the scientific return.

The compliant configuration, achieved with a 10 cm aperture telescope and consisting of an IFTS with Bands-1, 2, and 3a with no UVS instrument, compromises the SNR requirements. However, in spite of this, most, if not all of the MIR target gases will be within the threshold. Thus important numerical weather forecast (NWP) information, temperature and water vapour versus height will be retrieved, with a horizontal spatial resolution uncompromised. This latter point is extremely important, as if and when pixel averaging is required, the smaller pixels will provide better cloud clearing opportunities than larger pixels as described in the URD.

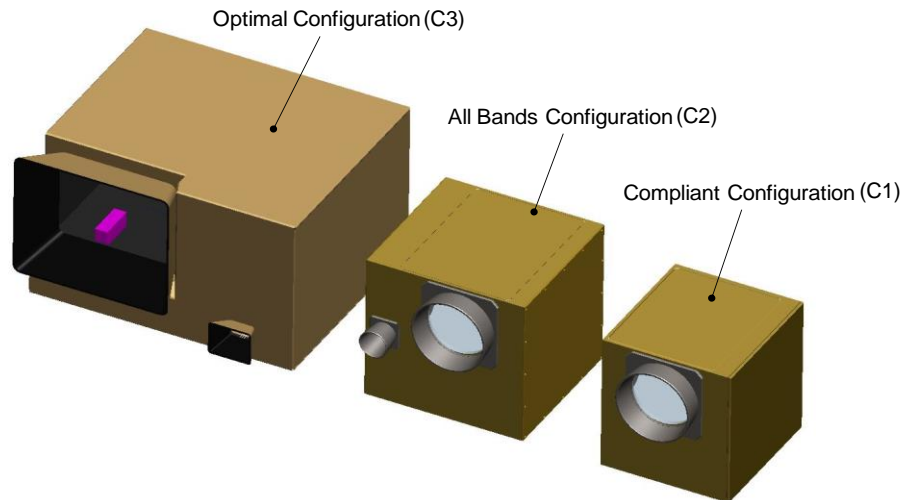

Figure 3: Preliminary design for the FTS/UVS instrument combination for PCW/PHEOS.

In addition, with the current MIR spectral range, ozone partial columns in the troposphere and stratosphere should be retrieved as well as tropospheric column  $\text{CO}$ . This represents all the target MIR air quality gases. As well as this, there are many other species which will be accessible on a serendipity basis, such as methanol,  $\text{HCN}$ ,  $\text{NH}_3$  or  $\text{SO}_2$  from volcanoes. Their detection may require some spatial averaging but the small  $10 \times 10 \text{ km}^2$  pixel size (our goal) will be better for cloud clearing than our threshold pixel size of  $20 \times 20 \text{ km}^2$ .

Greenhouse gases, methane, and  $\text{CO}_2$  are also accessible in the MIR Band-1 and 2, but there is reduced surface sensitivity in the MIR as compared to the near infrared (NIR) and only partial columns will be retrieved. However, the single NIR channel, Band-3a which targets methane, and which has always been a prime goal, should have adequate SNR because of the narrower spectral band; is expected to give excellent total column methane data. Lack of aerosol information from Band-4 is compromised for retrievals, but is much less serious for methane than for  $\text{CO}_2$  retrievals. Band-4 is missing, which targets aerosols and clouds. This information, which is useful for retrievals for GHG species in the NIR as scattering by aerosols, can impact the retrievals. However, the PCW meteorological imager can provide some information about the aerosol layer

The lack of a UVS instrument does compromise one of the target air quality gases,  $\text{NO}_2$ . Of course, tropospheric  $\text{O}_3$  is also compromised but, as noted above, there will be information from the FTS in the MIR, although the near-surface/lower troposphere information is less robust because of reduced thermal contrast in the lower atmosphere. In addition, it will not be possible to have access to the aerosol index, which is useful as it gives information on absorbing aerosol and its altitude.



In summary, it can be seen that the compliant version meets many of the objectives outlined in the URD. One of the target air quality gases is not obtained, namely tropospheric and stratospheric column NO<sub>2</sub>. And the total column GHG CO<sub>2</sub> is not measured although the partial column is measured. The lack of Band-4 and UVS limits aerosol information although semi-quantitative information can be obtained from the met-imager and the FTS can also detect volcanic ash. Some species of opportunity (e.g. HCHO) also would be lost.

For the configuration C2, the main differences from the compliant version above are the inclusion of Band-3b, which is broad enough to capture both CO<sub>2</sub> and methane, and the inclusion of Band-4 and the UVS instrument. The FTS aperture remains at 10 cm and so SNR does not change for Band-1 and 2. Band-3b differs in two ways from Band-3a, namely Band-3a is narrower and the SNR is higher than for the wider Band-3b. However Band-3b also includes CO<sub>2</sub> as well as methane and the CO<sub>2</sub> is an important target climate gas. The lower SNR compromises both the methane and CO<sub>2</sub> retrieval which would likely require pixel averaging as discussed in the URD. As noted above, the small pixel size ameliorates the poorer SNR as it can be enhanced by averaging local cloud-free pixels. Thus CO<sub>2</sub>, an important GHG, is accessible and preliminary OSSE-like calculations (Ray Nassar private communication, 2012) show that these temporally resolved measurements can have a dramatic impact on estimates of the CO<sub>2</sub> sources and sinks over the Boreal Forest.

In the case of the configuration C3, the instrument has the same bands as for C2 and thus the arguments about the scientific usefulness made for configuration C2 also apply to C3. The main difference between both configurations is that the SNR of the Optimal Configuration is improved so that goals are made rather than thresholds and this will likely lead to reduced spatial averaging. The relative sizes of the three concepts are shown in Figure 3.

The PCW mission is an innovative mission to provide communications and meteorological data for the Arctic and environs. PHEOS WCA will take advantage of the unique opportunity provided by the highly elliptical orbit planned for PCW to monitor the atmospheric and surface exchange processes taking place in the high northern latitudes not only to conduct atmospheric and climate research, but also monitoring of air quality and to complement the meteorological instrument of PCW by adding hourly sounding data to the information that will be collected by PCW.

## 11. ACKNOWLEDGEMENTS

The PHEOS-WCA Science Team Members are: York U.: B.H. Solheim, K. Semeniuk, Y. Chen, A. Lupu, I.C. McDade, J.J. Shan, W.F.J. Evans; U. Toronto: D. Jones, K.A. Walker, K. Strong, P.F. Fogal, Environment Canada: L. Garand, Y. Rochon, C. McLinden, R. Menard, D.S. Turner, R. Nassar; Dalhousie U.: J. Drummond, R. Martin, T. Duck; U. Saskatchewan: D. Degenstein, A. Bourassa; U. Sherbrooke: N. O'Neil, A. Royer; HCO/SAO: K. Chance; ISPL, ULB: C. Clerbaux; Carleton U.: A. Hakam; U. Waterloo: C. Boone; Xprime Consultants: J. Kaminski; Old Dominion U.: P. Bernath; RAL, UK: B. Kerridge; FMI: J. Tamminen; Yonsei U.: J. Kim; ECWMF: V.-H. Peuch. The team would like to thank the Canadian Space Agency for support.

## 12. REFERENCES

- [1] Trishchenko, A. P., L. Garand, and L. D. Trichtchenko. Three apogee 16-h highly elliptical orbit as optimal choice for continuous meteorological imaging of the polar regions. *J. Atmos. Oceanic Tech.*, **28**, 1407-1422, 2011. DOI: 10.1175/JTECH-D-11-00048.1
- [2] Wang, M., and J. E. Overland, A sea ice free summer Arctic within 30 years? *Geophys. Res. Lett.*, **36**, L07502, 2009, doi:10.1029/2009-GL037820.
- [3] Shakova *et al.*, Geochemical and geophysical evidence of methane release over the East Siberian Arctic Shelf, *J. Geophys. Res.*, **115**, C08007, doi:10.1029/2009JC005602, 2010.
- [4] Schurr, E.A.G, et al.: Vulnerability of Permafrost Carbon to Climate Change: Implications for the Global Carbon Cycle, *BioScience*, **58**, 8, 701-714, 2008.
- [5] Corbett, J.J., D. A. Lack, J. J. Winebrake, S. Harder, J. A. Silberman, and M. Gold, Arctic shipping emissions inventories and future scenarios, *Atmos. Chem. Phys.*, **10**, 9689-9704, 2010.
- [6] Walker *et al.*, Development of an FTS for thermal and near-infrared sounding of weather, air quality and greenhouse gases in the Arctic, *ATMOS-2012*, 2012 (abstract).
- [7] Rahnama, P., *et al.*, UV-VIS Spectrometer (UVS) for the Polar Communications and Weather (PCW) Mission, Proceedings of ASTRO'12, 16<sup>th</sup> CASI Astronautics conference, Quebec City, Canada, 24-26 Apr 2012, *Polar Communications and Weather Mission*, 186, 2012. Available at: <FTP://casi:ASTRO-2010@astroconference.ca>

- [8] McElroy *et al*, PCW/PHEOS UV-VIS Spectrometer: Air Quality from a Quasi-Geostationary Orbit, this issue, 2012.
- [9] Yurganov, L.N., W. W. McMillan, A.V. Dzhola, E. I. Grechko, N. B. Jones, and G. R. van der Werf, Global AIRS and MOPITT CO measure-ments: Validation, comparison, and links to biomass burning variations and carbon cycle, *J. Geophys. Res.*, 113, D09301, doi:10.1029/2007-JD009229, 2008.
- [10] Clerbaux, C., A. Boynard, L. Clarisse, M. George, J. Hadji-Lazaro, H. Herbin, D. Hurtmans, M. Pommier, A. Razavi, S. Turquety, C. Wespes, and P.-F. Coheur, Monitoring of atmospheric compos-ition using the thermal infrared IASI/MetOp sounder, *Atmos. Chem. Phys.* **9**, 6041-6054, 2009.
- [11] Guan, H., R. Esswein, J. Lopez, R. Bergstrom, A. Warnock, M. Follette-Cook, M. Fromm, and L. Iraci, A multi-decadal history of biomass burning plume heights identified using aerosol index measurements, *Atmos. Chem. Phys.*, **10**, 6461-6469, 2010.
- [12] Karagulian, F., L. Clarisse, C. Clerbaux, A. J. Prata, D. Hurtmans, and P. F. Coheur, Detection of volcanic SO<sub>2</sub>, ash, and H<sub>2</sub>SO<sub>4</sub> using the Infrared Atmospheric Sounding Interferometer (IASI). *J. Geophys. Res.*, **115**, D00L02, doi:10.1029/2009JD012786, 2010.
- [13] Lupu, A., J.W. Kaminski, L. Neary, J. C. McConnell, K. Toyota, C. P. Rinsland, P. F. Bernath, K. A. Walker, C. D. Boone, Y. Nagah-ama, and K. Suzuki, Hydrogen cyanide in the upper troposphere: GEM-AQ simulation and comparison with ACE-FTS observations, *Atmos. Chem. Phys.*, **9**, 4301–4313, 2009.
- [14] Toyota, K., J. C. McConnell, A. Lupu, L. Neary, C. A. McLinden, A. Richter, R. Kwok, K. Semeniuk, J.W. Kaminski, S.-L. Gong, J. Jarosz, M. P. Chipperfield, and C. E. Sioris, Analysis of reactive bromine production and ozone depletion in the Arctic boundary layer using 3-D simulations with GEM-AQ: inference from synoptic-scale patterns, *Atmos. Chem. Phys.*, **11**, 3949–3979, 2011
- [15] Krijger, J.M., van Weele, M. and Frey, R., Technical Note: The effect of sensor resolution on the number of cloud-free observations from space, *Atmos. Chem. Phys.*, **7**, 2881-2891, 2007.
- [16] McNally, A. P., and P.D. Watts, A cloud detection algorithm for high-spectral-resolution infrared sounders, *Q. J. R. Meteorol. Soc.*, **129**, 3411–3423, 2003. doi: 10.1256/qj.02.208
- [17] McNally, A. P., The direct assimilation of cloud-affected infrared radiances in the ECMWF 4D-Var, ECMWF/EUMETSAT NWP-SAF Workshop on the assimilation of IASI in NWP, 6 – 8 May 2009.