

Woodchip drying in a screw conveyor dryer

Ozgur Kaplan and Cenk Celik

Citation: *J. Renewable Sustainable Energy* 4, 063110 (2012); doi: 10.1063/1.4766890

View online: <http://dx.doi.org/10.1063/1.4766890>

View Table of Contents: <http://jrse.aip.org/resource/1/JRSEBH/v4/i6>

Published by the [American Institute of Physics](#).

Related Articles

Effects of volumetric dilution on anaerobic digestion of food waste
J. Renewable Sustainable Energy 4, 063112 (2012)

Numerical study on aerodynamic performances of the wind turbine rotor with leading-edge rotation
J. Renewable Sustainable Energy 4, 063103 (2012)

Actuation abilities of multiphasic electroactive polymeric systems
J. Appl. Phys. 112, 094108 (2012)

Smart textiles: Challenges and opportunities
App. Phys. Rev. 2012, 10 (2012)

Smart textiles: Challenges and opportunities
J. Appl. Phys. 112, 091301 (2012)

Additional information on J. Renewable Sustainable Energy

Journal Homepage: <http://jrse.aip.org/>

Journal Information: http://jrse.aip.org/about/about_the_journal

Top downloads: http://jrse.aip.org/features/most_downloaded

Information for Authors: <http://jrse.aip.org/authors>

ADVERTISEMENT



AIP | Journal of Renewable and Sustainable Energy

Sign Up For the Free Newsletter Today!

AIP | Journal of Renewable and Sustainable Energy

The advertisement features a green background with a white box containing the text "Sign Up For the Free Newsletter Today!". To the right, there is a small image of the journal cover, which shows a red building with solar panels on the roof, set against a blue sky and ocean. The journal title "AIP | Journal of Renewable and Sustainable Energy" is visible at the top of the cover image.

Woodchip drying in a screw conveyor dryer

Ozgur Kaplan and Cenk Celik^{a)}

Department of Mechanical Engineering, Kocaeli University, 41380 Kocaeli, Turkey

(Received 26 May 2012; accepted 25 October 2012; published online 13 November 2012)

Moisture content of raw biomass materials is a crucial parameter for system efficiency and the main purpose of the drying process is to reduce moisture content of the wet biomass. In this study, the drying characteristics of woodchip dried in a screw conveyor dryer had investigated experimentally. The experimental results demonstrated that drying rate had increased with the increasing drying air temperature and flow rate; however, the amount of volatile organic matters in the sample has kept constant. Furthermore, the results have showed that the best drying conditions in this study is 30 m³/h drying airflow rate, 200 °C drying air temperature, and co-current dryer type. With these conditions, moisture content of woodchip decreased from 60% to 27% (wet basis, mass %). © 2012 American Institute of Physics. [<http://dx.doi.org/10.1063/1.4766890>]

I. INTRODUCTION

Wood is thought to be the first source of energy of human kind. Today, wood is the most important renewable source of energy in the world.¹ In 2007, 13% of the energy consumed in the world is generated from wood. 77% of the renewable energy is produced from biomass. In total, 8.7% of the energy consumed in the world is produced from wood.² In April 2009, the European Parliament and Council adopted a Directive (2009/28/EC) on the promotion of the use of energy from renewable sources, while the Europe 2020 strategy (approved in June 2010) confirmed an EU target such that 20% of energy should come from renewable sources by 2020.³ Experts believe that biomass is likely to contribute half the 20% renewable energy target.⁴

Wood can be converted to energy via various technologies. These technologies can be divided into two main topics: thermochemical and biochemical processes. Digestion and fermentation can be considered as biochemical processes. Biochemical processes operated in a solution and moisture content of wood are not an issue in this energy conversion type. Thermochemical processes consist of combustion, gasification, and pyrolysis.⁵ In combustion process, higher moisture content of wood causes operational problems, decrease in the combustion temperature, and combustion efficiency. In gasification process, higher tar concentration and decrease in the lower heating value of the syngas is a result of usage of wood with higher moisture content.⁶ The moisture content of the biomass has a significant impact on pyrolysis process. Moisture content of the wood affects the conversion efficiency and the quality of the liquid product, in which final moisture content of the liquid product needs to be in a range of 5%–10%.⁵

Biomass materials can be dried with:

- through-circulation dryer (perforated floor dryer)
- packed moving bed dryer
- direct and indirect rotary dryer (rotary cascade dryer and steam-tube dryer)
- fluidized bed dryer
- pneumatic conveying dryer (flash dryer).

^{a)} Author to whom correspondence should be addressed. Electronic addresses: cenkcelik@kocaeli.edu.tr and c.celik@ucl.ac.uk. Tel.: +90 262 3033419. Fax: +90 262 3033003.

Drying medium for these types of dryers can be hot air, flue gas, and superheated steam. Woodchips are most commonly dried with packed moving bed dryers, rotary dryers, and pneumatic (or flash) dryers in the industry.⁵

Packed moving bed dryers are also known as conveyor dryers. Wet wood chips are fed from the left side of the conveyor and create a loosely compacted bed on the conveyor that has a perforated belt that lets hot air pass through the bed of woodchips and dries them. Drying time can be controlled by controlling the speed of conveyor. Under stable operating conditions, the volume of wet chips is fed at a constant mass flow rate and the drying time is controlled based on the final moisture content.⁷

Most of the rotary dryers in industry are direct contact type dryers. Direct contact rotary dryers consist of a hollow, rotational metal cylinder providing space for direct contact between the material to be dried and the drying medium, usually hot air. During the direct contact, the heat and mass transfer between those two streams is high. This transfer is increased by a series of flights installed on the inner surface of cylinder. When the cylinder is rotating, the flights lift the solid material within the cylinder from bottom to top. During the rotation, the materials are dropped from top to the bottom through the hot air. In addition, uniform moisture content distribution of the dried product can be achieved, because every piece of the solid material has an equal chance of contact with the hot air.⁸

Pneumatic dryers are gas–solid transport systems with continuous convective heat and mass transfer process. This type of dryer can achieve rapid drying with short residence time by fully immersing the material in a high velocity gas flow. In the dryer, the hot gas stream transports the solid particles through a pipe or flow duct and makes direct contact with the material to be dried. This gas stream is also a drying medium to supply the heat required for drying and carries away the evaporated moisture.⁵

A detailed review about these dryers can be found in Pang *et al.*⁵ And also, further reading about industrial dryers can be found in Mujumdar.⁹

Waje *et al.* conducted a series of experiments and published several papers about screw conveyor dryer.^{10–13} They investigated residence time distribution (RTD) and mean residence time (MRT) in screw dryer conveyor and found out that with the increasing screw speed, degree of mixing is increased but MRT is decreased. The flow in a screw conveyor dryer approaches plug flow as the feed rate is increased, whereas an increase in the screw speed results in a mixed flow.¹⁰ The MRT can be better controlled with screw speed rather than the solids flow rate. The discharge uniformity was found to be a strong function of the solids flow rate and the screw speed.¹¹

In this paper, the drying characteristics of woodchip dried in a screw dryer have been investigated and the optimum drying conditions have been determined.

II. EXPERIMENTAL

A. Materials

The wood used in the experiments has been provided from The General Directorate of Forestry. It has been crushed and sifted to 0–2 mm woodchips at the Fuel Processing Laboratories of The Scientific and Technological Research Council of Turkey (TÜBİTAK), Marmara Research Center, Energy Institute. Elemental analysis has been applied to the woodchip samples using LECO Truspec CHN-S Elemental Analysis equipment. Carbon (C), hydrogen (H), and nitrogen (N) contents of sample are investigated under ASTM 5373 standard and sulfur content investigated under ASTM D 4239 standards. Results of these analyses are given in Table I.

TABLE I. Elemental analysis of sessile oak woodchip (dry basis, % mass).

Biomass type	C (%)	H (%)	N (%)	S (%)	O (%)
Turkish pine	56.26	8.9	0.24	0	32.72

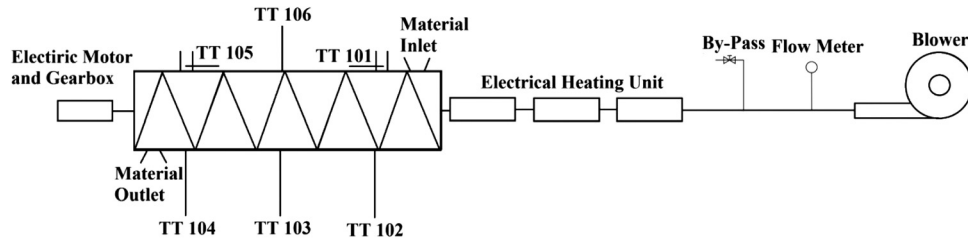

FIG. 1. Schematic of experimental setup.

The moisture content of the wet and dried woodchips is measured in each experiment. For moisture content measuring, Sartorius MA100 thermogravimetric moisture content measurement equipment is used.

Also, a proximate analysis (ASTM E-1755) is applied to the wet and dried biomass samples. The moisture content, volatile organic matter, fixed carbon, and ash content of wood chips are obtained with this analysis to determine whether if any drying based volatile organic matter emissions are releasing or not.

The experimental setup consists of an air blower, electrical heating unit, screw conveyor, and air distribution pipes. Schematic of experimental setup is given in Fig. 1.

Ambient air is sent to the electrical heating system by a blower to heat the drying air. The hot drying air is delivered to the screw conveyor where it meets with wet woodchips. Drying air can be delivered to the screw conveyor from both sides with pipe 1 and pipe 2. Therefore, the dryer can be operated in both co-current and counter-current conditions. Six thermocouples are connected to the system. TT101 thermocouple measures air inlet temperature in co-current flow direction and air outlet temperature in counter-current condition (Fig. 2). Similarly, TT 105 thermocouple measures air outlet temperature in co-current and air inlet temperature in counter-current flow direction. TT106 thermocouple measures outside surface temperature of conveyor housing (on the aluminum sheet that covers insulation material). TT102, TT103, and TT104 thermocouples measure inside dryer temperature.

The air supply blower has an input power of 2.2 kW motor and delivers approximately 250 m³/h of air at a maximum head pressure drop of 280 mbar. A frequency modulator controls the air flow rate. The air is heated by electrical heater, which has a power of 4.5 kW and is controlled with contactors. A 0.37 kW electric motor and redactor set are used for rotating the screw and it is controlled by a frequency modulator. The flow rate of air is measured with Bass Instruments FOFT-025 orifice type flow meter. Humidity and temperature of ambient air are measured with Kimo TH-300 humidity sensor. Thermocouples along the dryer and at the pipes are NiCr-Ni type-K and have an accuracy of 0.1 °C. All the measurement equipments are connected to Ahlborn Almemo MA 5690-1 data logger and data logger is connected to a PC via

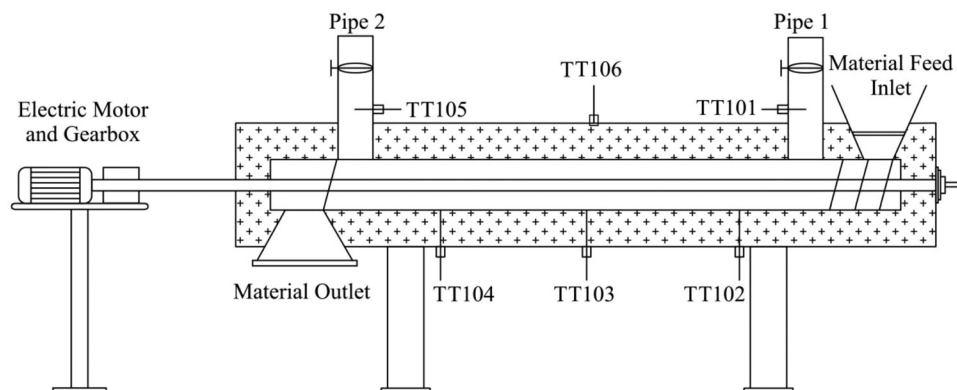

FIG. 2. Schematic of screw conveyor dryer.

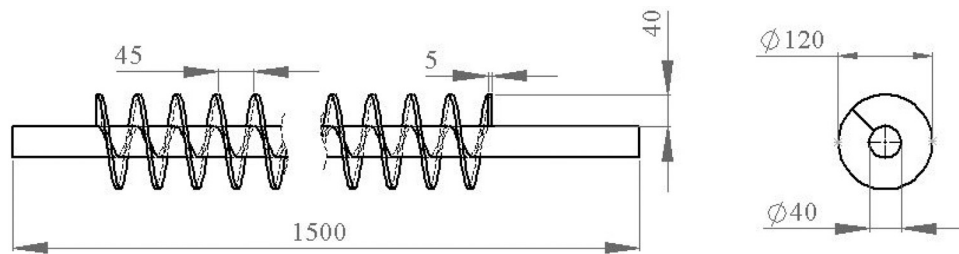

FIG. 3. Dimensions of the screw.

RS232 serial port. The data collected from measurement equipments are logged with an AMR Win Control computer program.

Cylindrical housing of the screw conveyor is made from 5 in. drawn steel pipe. Screw of the conveyor has an outside diameter of 120 mm and has 45 mm pitch. Length of screw is 1.5 m and drying zone (between the inlet and the outlet pipes) of the dryer is 1 m long.

Dimensions of the screw are given in Fig. 3. Air distribution pipes are made from 3 in. drawn steel pipe. Both the housing of the conveyor and the air distribution pipes are insulated with 50 mm ceramic wool.

B. Method

Experiments are conducted under $F_1 = 20 \text{ m}^3/\text{h}$ and $F_2 = 30 \text{ m}^3/\text{h}$ air flow rates. Three different air inlet temperatures ($T_1 = 150^\circ\text{C}$, $T_2 = 175^\circ\text{C}$, and $T_3 = 200^\circ\text{C}$) are selected for both co-current and counter-current flow direction conditions. The test matrix is given in Table II.

Revolution of the screw is kept constant as 18 rpm and total of 1.5 kg wet woodchip is fed to the bunker of drying system for each experiments. For both co-current and counter current flow conditions, the wet biomass in the fuel bunker passes through the screw pipe, and delivers to the storage tank at the exit. The one passing time of 1.5 kg of wet biomass inside the screw conveyor is around 3.15 min at 18 rpm screw speed. Initial moisture of wood chips used in the experiments is kept same as (60%, wet basis, % mass) for each set of experiments. 1.5 kg of wet woodchip is fed to the dryer and dried four times in the same conditions and at the end of each experiment, a sample is collected from dried woodchips for moisture content analysis. Moisture content of this sample is measured on wet basis. Also, a short analysis (ASTM E-1755) is applied to the four time dried woodchip sample and its volatile organic compound (VOC) is investigated and compared with the original (non-dried) sample of woodchip.

III. RESULTS AND DISCUSSION

The effects of different drying conditions to the drying process are investigated in this study. Bar graphics are drawn with the final (after drying four times) moisture content of woodchip. These graphics are useful to see the effects of drying conditions to drying process.

Fig. 4 shows the moisture content of four times dried wood chips at different drying conditions (flow rates, drying air temperatures, and flow directions). As shown in this figure, the moisture content of woodchips decreased for all cases with increasing drying air temperature.

TABLE II. The test matrix.

	Co-current			Counter current		
T ($^\circ\text{C}$)	150	175	200	150	175	200
F_1 (m^3/h)	20	20	20	20	20	20
F_2 (m^3/h)	30	30	30	30	30	30

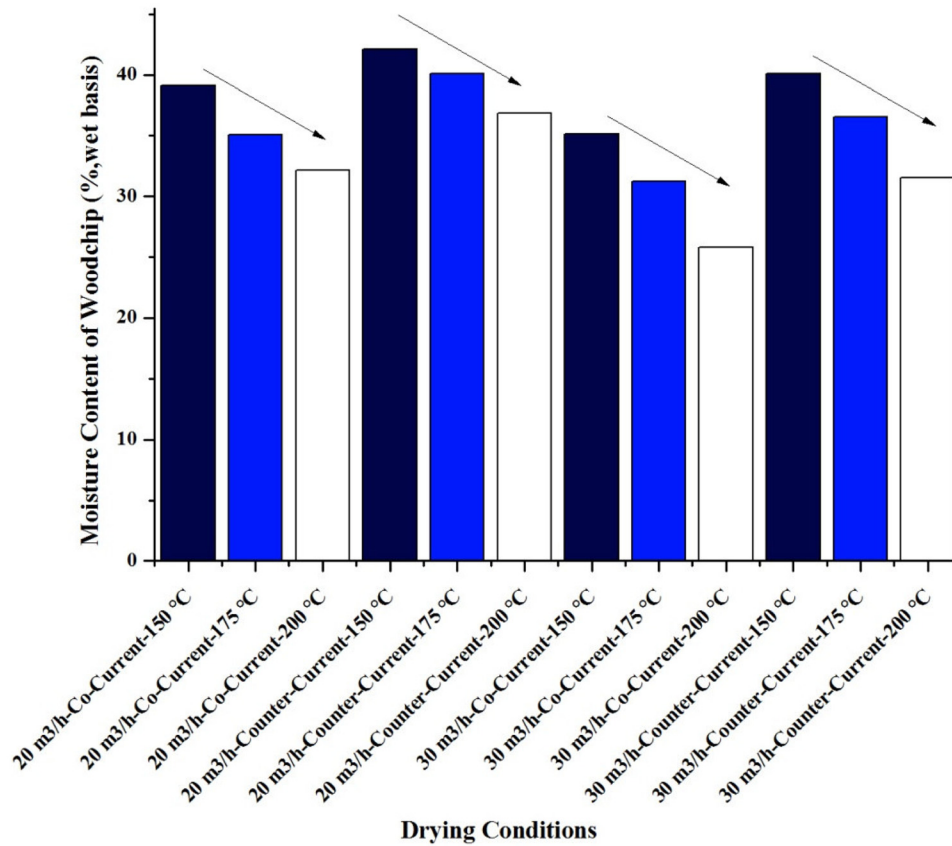

FIG. 4. The effect of drying air temperature to drying process.

The reason of this decrease of moisture content can be explained with the increasing heat transfer between the drying air and the woodchips.

Fig. 4 was re-designed to show the effect of drying air flow rate on drying process (Fig. 5). Moisture content of woodchip decreased by increasing the drying air flow rate in all conditions. It is because, the increase in the drying air flow rate increases the net energy transfer to the dryer. Energy balance for drying air can be written as in the following equation:

$$Q = \dot{m}_{\text{air}} \times (h_{\text{air inlet}} - h_{\text{air outlet}}). \quad (1)$$

In this equation, \dot{m}_{air} is the mass flow rate of drying air, $h_{\text{air inlet}}$ is the enthalpy of the drying air at the dryer inlet, and $h_{\text{air outlet}}$ is the enthalpy of the drying air at the dryer outlet. The increase in the volumetric flow rate also increases the mass flow rate. Thus, the increase in both the drying air temperature and the drying air flow rate increases the net energy transferred to the dryer. Some part of this energy dries the woodchip; some part of it is the heat loss to the surrounding ambient. Since it is a well insulated dryer, heat loss to the surroundings can be ignored. In that case, all the energies transferred to the dryer are used in the drying process. This means that the increase in the drying air flow rate increases the heat transferred to the woodchip.

A bar graph of moisture content of woodchip against drying conditions is presented in Fig. 6. This graph was re-designed from Fig. 6 to see the effect of drying type to drying of woodchip. In this figure, it can be seen clearly that regardless from other drying conditions (drying air temperature and drying air flow rate) with co-current drying, lower moisture contents can be reached compared to counter-current drying. It is thought to be that in counter-current drying, drying air losses from material outlet section is greater than drying air losses from material feed inlet section

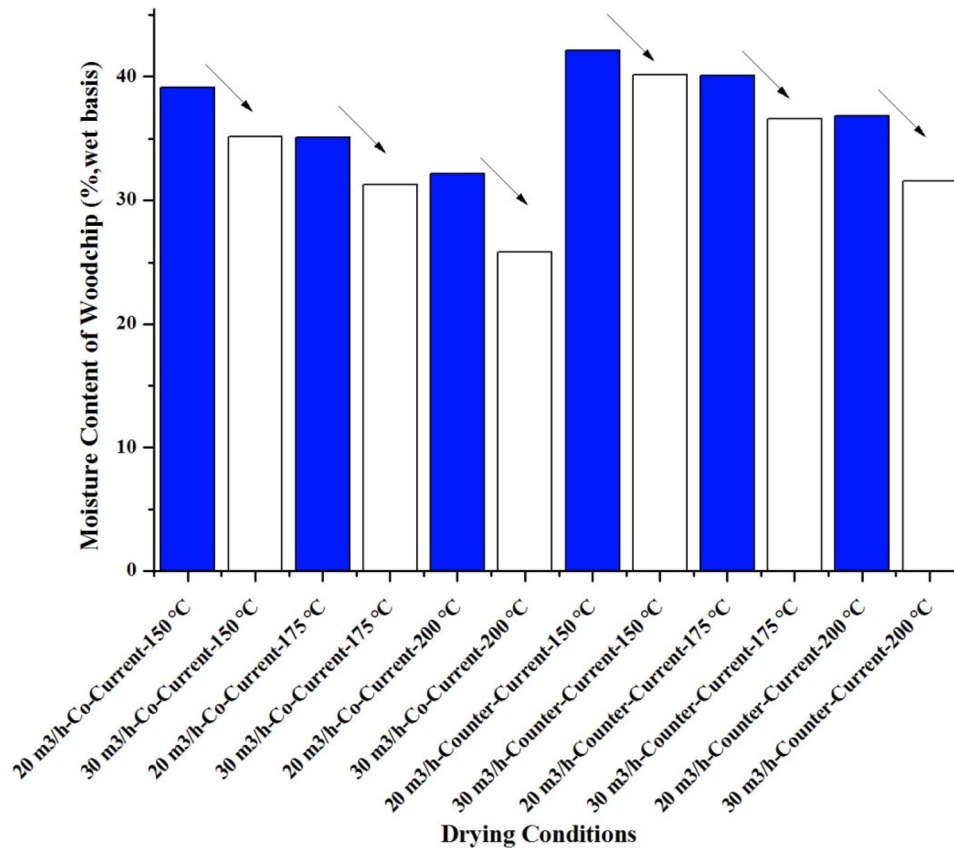

FIG. 5. The effect of drying air flow rate to drying process.

in co-current. That could be the reason why with co-current dryer setup lower moisture contents can be reached.

In total, 48 experiments are conducted in this project. In each experiment, a small amount of sample is collected, and the moisture content and temperature of this woodchip are measured. The change of moisture content of woodchip against drying step-dryer length is presented in Fig. 7. These curves were drawn under 20 m³/h drying air flow rate, co-current dryer setup, and various drying air temperatures 150 °C, 175 °C, and 200 °C. The initial moisture content of woodchip was 60% (wet basis, mass %). Similarly, Figs. 8–10 are drawn with different flow rates and drying setups, the drying air temperatures were the same as 150 °C, 175 °C, and 200 °C.

Change of the temperature of woodchip against drying step-dryer length is shown in Fig. 11. These curves are drawn under 20 m³/h drying air flow rate, co-current dryer setup, and various drying air temperatures 150 °C, 175 °C, and 200 °C. The initial temperature of woodchip was 13.5 °C. Similarly, Figs. 12 and 13 were drawn with different flow rates and drying setups, the drying air temperatures are the same as 150 °C, 175 °C, and 200 °C.

In Figs. 7–10, moisture content against drying step-dryer length curves was given and it tends to be in linear form. First-degree equations are fitted to these curves and it is found that the lower coefficient of determination is 0.91442. The linear form of this curve shows that the drying process takes place in the constant drying rate period.¹⁴

In the constant-rate period of drying, moisture movement within the solid is rapid enough to maintain a saturated condition at the surface, and the rate of drying is controlled by the rate of heat transferred to the evaporating surface. Drying proceeds by diffusion of vapor from the saturated surface of the material across a stagnant air film into the environment. The rate of mass transfer balances the rate of heat transfer, and the temperature of the saturated surface remains constant.¹⁴

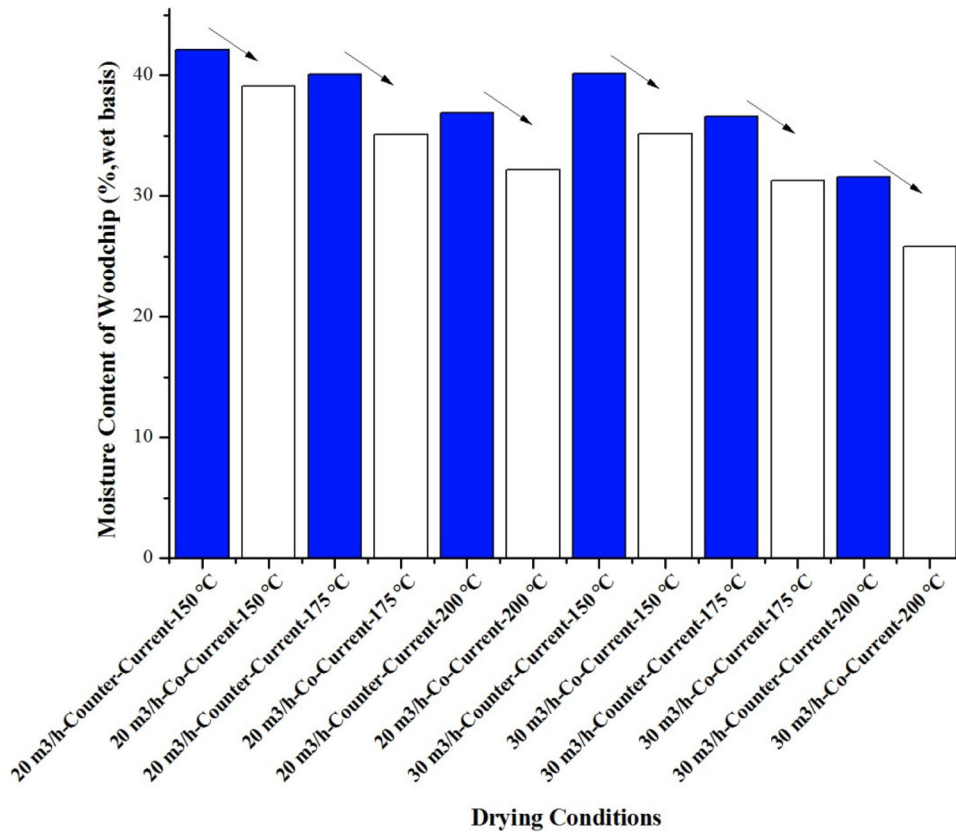

FIG. 6. The effect of drying type to drying process.

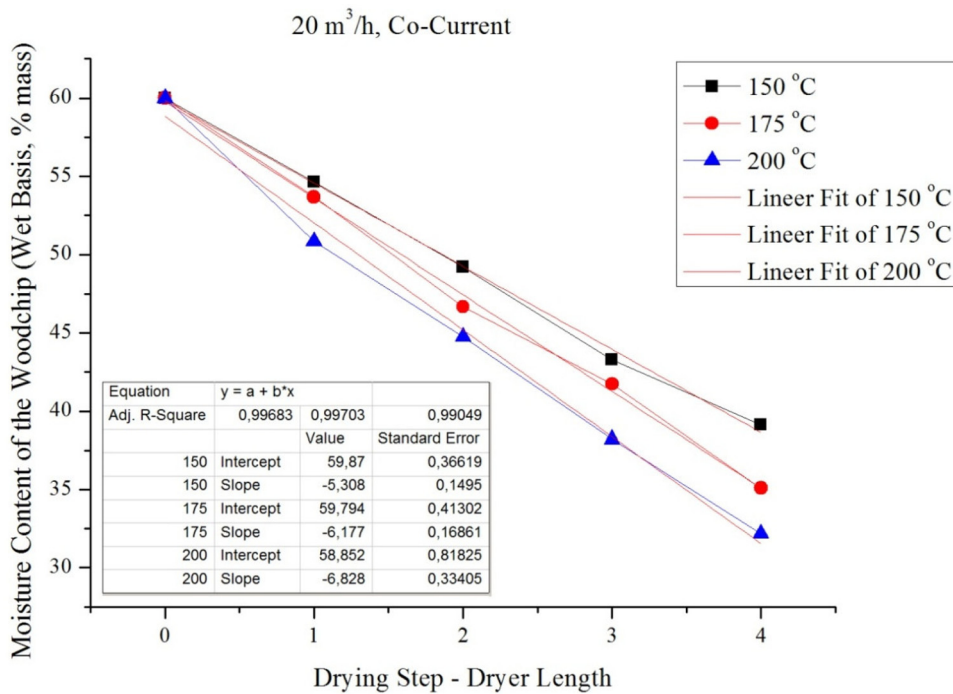

FIG. 7. Change of moisture content of woodchip under 20 m³/h drying air flow rate, co-current dryer type, and various drying air temperatures.

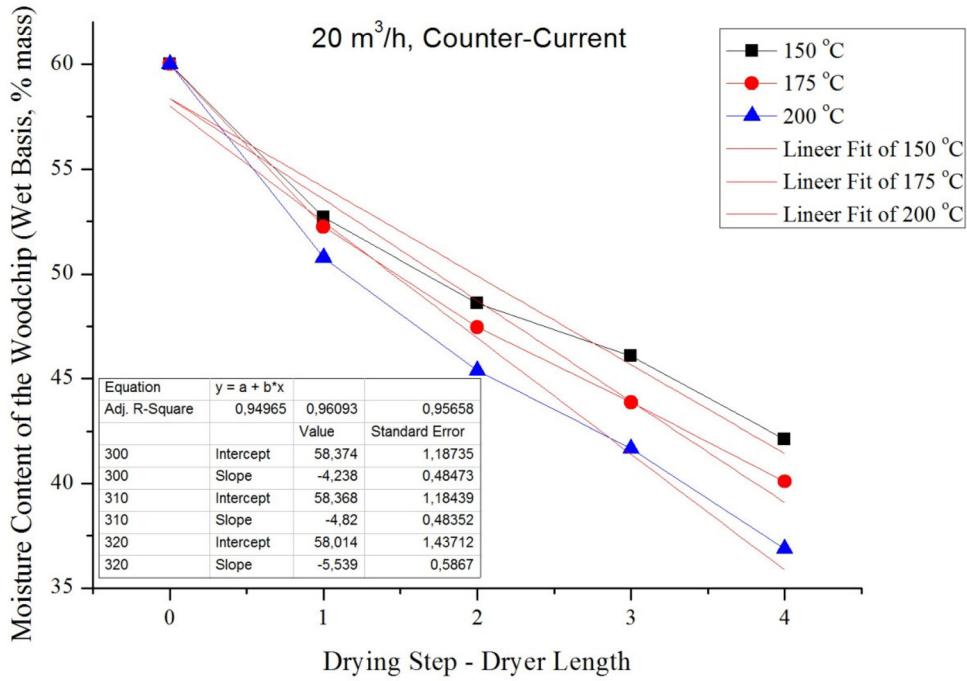

FIG. 8. Change of moisture content of woodchip under 20 m³/h drying air flow rate, counter-current dryer type, and various drying air temperatures.

In Figs. 11–13, temperatures of woodchip against drying step-dryer length curves are also given. In the all curves, in the first step of drying, there is a peak point. After that point, temperature of woodchip decreases and stays constant. These results are consistent with the theory.

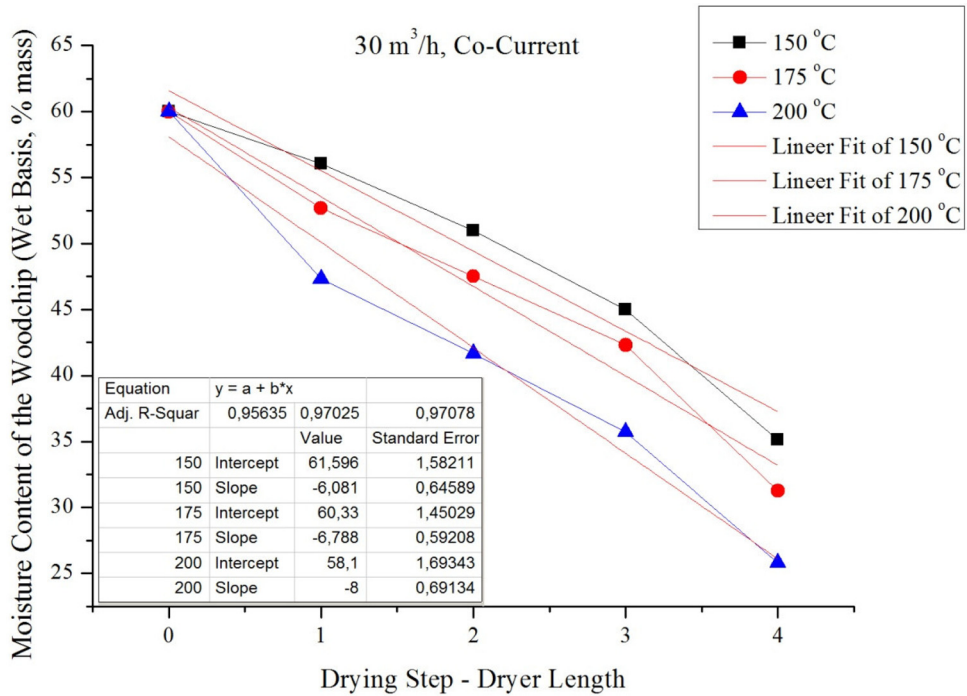

FIG. 9. Change of moisture content of woodchip under 30 m³/h drying air flow rate, co-current dryer type, and various drying air temperatures.

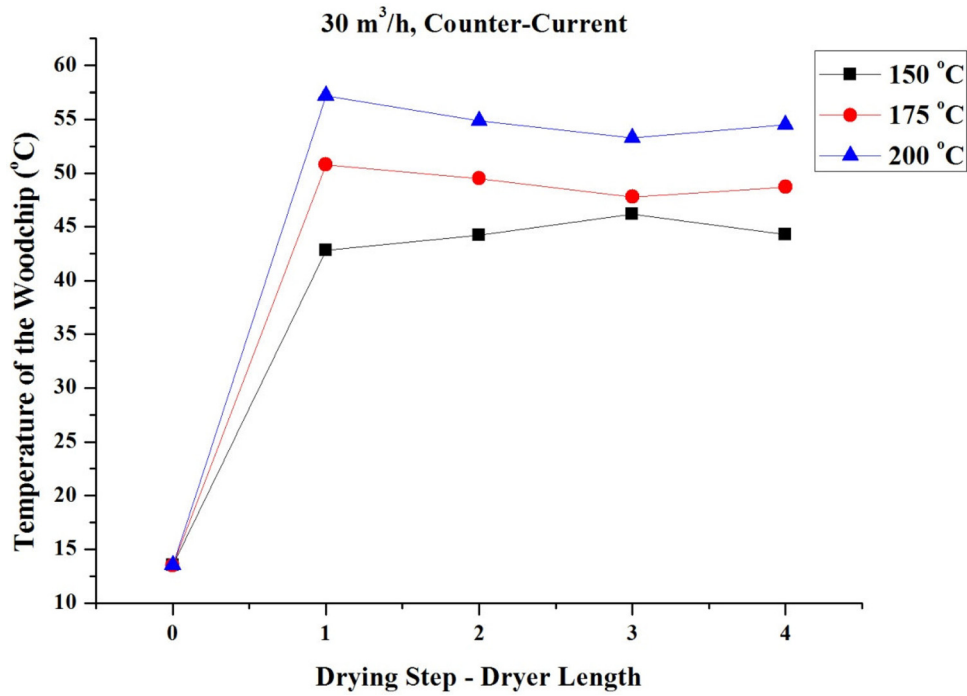

FIG. 10. Change of temperature of woodchip under 30 m³/h drying air flow rate, counter-current dryer type, and various drying air temperatures.

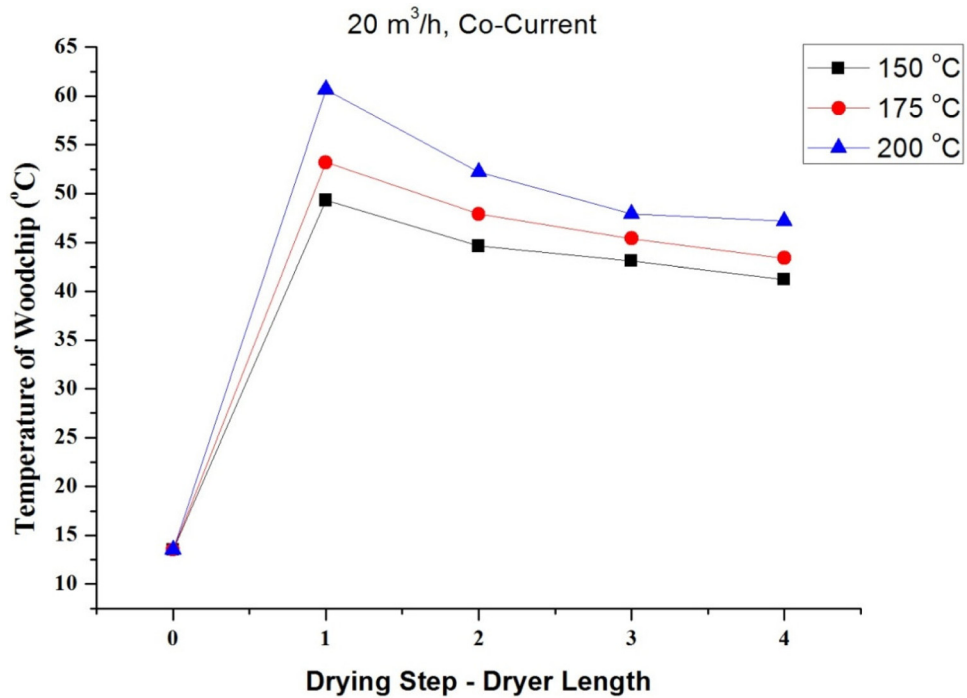

FIG. 11. Change of temperature of woodchip under 20 m³/h drying air flow rate, co-current dryer type, and various drying air temperatures.

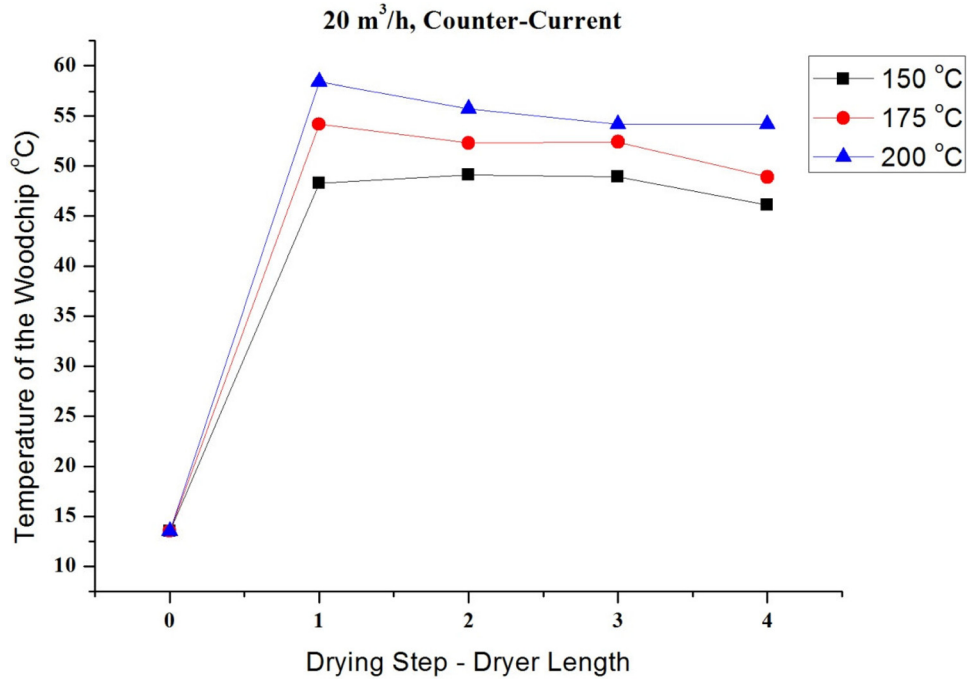

FIG. 12. Change of temperature of woodchip under 20 m³/h drying air flow rate, counter-current dryer type, and various drying air temperatures.

In Table III, short analysis (ASTM E-1755) results of both original (wet) and dried samples are presented. Original (wet) woodchip sample consisted of 80.96% volatile organic compound in its structure. Under all drying conditions, volatile organic compound amounts are nearly the same. The biggest change in the amount of volatile organic matter was at 30 m³/h drying air

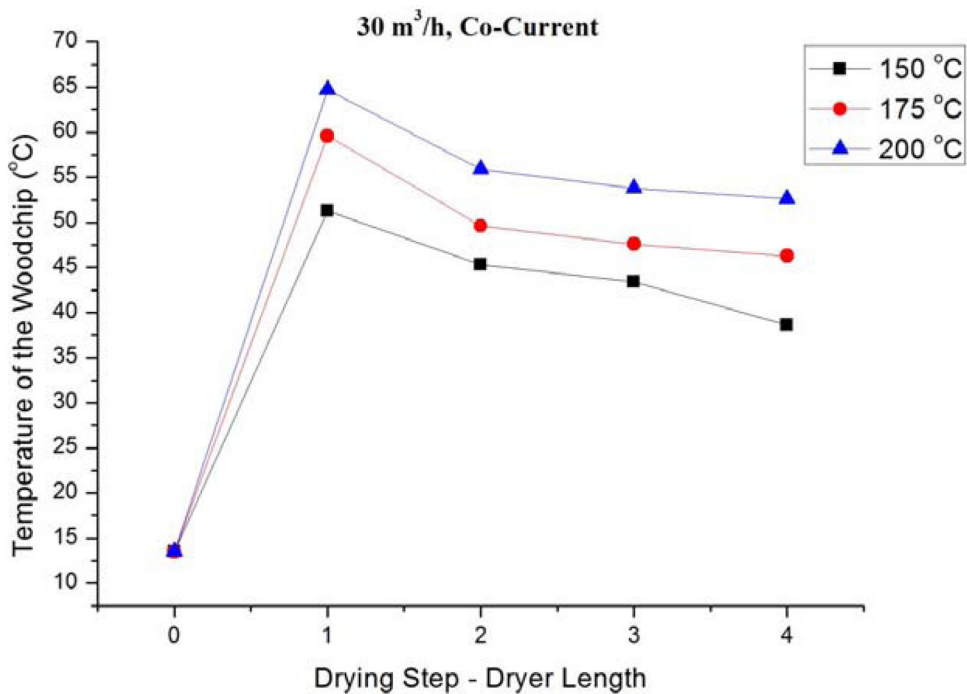

FIG. 13. Change of moisture content of woodchip under 30 m³/h drying air flow rate, counter-current dryer type, and various drying air temperatures.

TABLE III. Short analysis (ASTM E-1755) results of dried and original (wet) woodchips (dry basis, mass %).

Drying conditions (drying air flow rate, drying type, drying air temperature)	Ash	Volatile organic compound	Fixed carbon
Original sample (wet sample)	1.41	80.96	17.63
20 m ³ /h, Co-current, 150 °C	1.53	80.26	18.20
20 m ³ /h, Co-current, 175 °C	1.26	80.26	18.48
20 m ³ /h, Co-current, 200 °C	1.65	79.88	18.48
20 m ³ /h, Counter-current, 150 °C	1.45	80.27	18.27
20 m ³ /h, Counter-current, 175 °C	1.49	80.95	17.56
20 m ³ /h, Counter-current, 200 °C	1.46	80.24	18.30
30 m ³ /h, Co-current, 150 °C	1.70	80.16	18.14
30 m ³ /h, Co-current, 175 °C	1.54	79.81	18.65
30 m ³ /h, Co-current, 200 °C	1.43	80.41	18.15
30 m ³ /h, Counter-current, 150 °C	1.52	80.66	17.82
30 m ³ /h, Counter-current, 175 °C	1.78	80.40	17.82
30 m ³ /h, Counter-current, 200 °C	1.96	79.49	18.55

flow rate, 200 °C drying air temperature, and counter-current dryer setup and it was only 1.8%, which was negligible. These results show that under all drying conditions investigated in this study, structure of the woodchip stayed intact, and no drying based volatile organic matter emissions are released.

IV. CONCLUSIONS

Drying of Turkish Pine woodchip is investigated under various drying conditions in this study. It is found that the increase in both the drying air temperature and the flow rate of drying air increased the rate of evaporation during drying. Co-current dryer setup also provided the increase in the rate of evaporation.

Nevertheless, the experimental results showed that the drying air flow rate should not exceed 30 m³/h since higher flow rates create operational problems such as woodchip blowing out from the chimney and the material feed inlet. Therefore, if higher flow rates are needed, a cyclone and a bag filter should be added to the exit of chimney.

It is observed that there were no drying based emissions releasing at 200 °C drying air temperature. Higher temperatures should be investigated to find the maximum temperature to operate the screw conveyor dryer.

The experimental results showed that the best drying conditions in this study are 30 m³/h drying air flow rate, 200 °C drying air temperature, and co-current dryer type. With these conditions, moisture content of woodchip decreased from 60% to 27% (wet basis, mass %).

ACKNOWLEDGMENTS

This work was done at Fuel Processing Laboratories of Tübitak, Marmara Research Center, Energy Institute. The authors are grateful to the Tübitak. The authors also appreciate Mr. H. İbrahim Saraç, Mr. Hayati Olgun, and Mr. Awf Al Kassir for providing technical support, Mrs. Berrin BAY for her help in the ASTM E-1755 analysis, Mr. Erkutay Taşdemirci for his help in overcoming technical issues during the experiments, Mr. William Neuheisel, Ms. Nuriye Kalem, Mr. Mert Tükel, and Mr. Berkan Uzun for their help in writing the article.

¹See <http://www.fao.org/forestry/energy/en/> for the importance of the wood.

²World Energy Council, 2010 survey of energy resources, 2010.

³Forestry in EU and World, European Commission, 2010.

⁴See <http://www.erec.org/renewable-energy/bioenergy> for understanding of the expertise belief about biomass.

⁵S. Pang and A. S. Mujumdar, "Drying of woody biomass for bioenergy: Drying technologies and optimization for an integrated bioenergy plant," *Drying Technol.* **28**(5), 690–701 (2010).

- ⁶K. Svoboda, J. Martinec, M. Pohořely, and D. Baxter, "Integration of biomass drying with combustion/gasification technologies and minimization of emissions of organic compounds," *Chem. Pap.* **63**(1), 15–25 (2009).
- ⁷S. Pang and Q. Xu, "Drying of woody biomass for bioenergy using packed moving bed dryer: Mathematical modeling and optimization," *Drying Technol.* **28**(5), 702–709 (2010).
- ⁸Q. Xu and S. Pang, "Mathematical modeling of rotary drying of woody biomass," *Drying Technol.* **26**(11), 1344–1350 (2008).
- ⁹A. S. Mujumdar, *Handbook of Industrial Drying* (CRC, 2006).
- ¹⁰S. S. Waje, B. N. Thorat, and A. S. Mujumdar, Study of residence time distribution in a pilot scale screw conveyor dryer, *Drying Technol.* **25**(1), 249–259 (2007).
- ¹¹S. S. Waje, B. N. Thorat, and A. S. Mujumdar, "Hydrodynamic characteristics of a pilot scale screw conveyor dryer," *Drying Technol.* **25**(4), 609–616 (2007).
- ¹²S. S. Waje, B. N. Thorat, and A. S. Mujumdar, "Screw conveyor dryer: Process and equipment design," *Drying Technol.* **25**(1), 241–247 (2007).
- ¹³S. S. Waje, B. N. Thorat, and A. S. Mujumdar, "An experimental study of the thermal performance of a screw conveyor dryer," *Drying Technol.* **24**(3), 293–301 (2007).
- ¹⁴H. R. Perry and W. D. Green, *Perry's Chemical Engineers' Handbook*, 7th ed. (McGraw Hill, 1999), pp. 12-31–12-32.