

**GLOBAL BUSINESS AND TECHNOLOGY
ASSOCIATION**

**CHANGING BUSINESS ENVIRONMENT:
GAMECHANGERS, OPPORTUNITIES AND RISKS**



ISBN: 1-932917-13-6

ISSN: 2520-6486

Editors:

N. Delener, Ph.D.

Christina Schweikert, Ph.D.

**GLOBAL BUSINESS AND
TECHNOLOGY ASSOCIATION**

**NINETEENTH ANNUAL
INTERNATIONAL CONFERENCE**

READINGS BOOK

ISBN: 1-932917-13-6

ISSN: 2520-6486

**CHANGING BUSINESS ENVIRONMENT:
GAMECHANGERS, OPPORTUNITIES AND RISKS**

Editors:

N. Delener, Ph.D

Christina Schweikert, Ph.D.

VIENNA, AUSTRIA

July 11-15th, 2017

**PUBLISHED BY THE
GLOBAL BUSINESS AND TECHNOLOGY ASSOCIATION
P.O. BOX 8021 | NEW YORK, NEW YORK 10116 | U.S.A.**

ISBN: 1-932917-13-6

ISSN: 2520-6486

The materials published in this Readings Book may be reproduced for instructional and noncommercial use. Any use for commercial purposes must have the prior approval of the President of the Global Business and Technology Association.

All full papers submitted to the Global Business and Technology Association Conferences are subject to a peer reviewing process, using subject specialists selected for their expert knowledge in the areas.

The Global Business and Technology Association (GBATA) is listed with EBSCO and ProQuest. This allows researchers from throughout the world to access articles from the Readings Book.

Published in the United States of America, 2017

FORWARD

The purpose of the conference is to provide a unique international forum to facilitate the exchange of cutting-edge information through multidisciplinary presentations of new challenges in global business and technology strategies, policies and issues.

All full papers submitted to the Global Business and Technology Association Conferences are subject to a peer reviewing process, using subject specialists selected because of their expert knowledge in the areas.

Academicians, practitioners, and public policy makers at all levels throughout the world submitted original papers for conference presentation and for publication in this Readings Book. All competitive papers were refereed (subject to a peer review). The result of these efforts produced 329 empirical, conceptual and methodological papers involving all functional areas of business education with a special focus on international aspects. Of the 208 papers accepted for presentation at the conference, 108 papers are published in this Readings Book.

ACKNOWLEDGEMENT

Many people and organizations are responsible for the successful outcome of the Nineteenth Annual International Conference of the Global Business and Technology Association (GBATA). GBATA extends its many thanks to the financial sponsors of this conference: Austrian Federal Economic Chamber, Austria; Federal Ministry of Science, Research and Economy, Austria; and the Polytechnic Institute of Leiria, Portugal.

A successful conference could not be possible without the special cooperation and care of the program committee members. Furthermore, many thanks go to the reviewers for their time spent on the many papers that were submitted to this conference.

A special thanks as well to the session chairs and discussants for taking the extra time to make this conference a success. Last but not least, an important acknowledgement to all these who submitted their work to be considered for presentation at the conference.

N. Delener, Ph.D.
President, GBATA

REVIEWERS

Ryma Abassi, ISET COM, Tunisia
Salima Abbas, ISET COM, Tunisia
Samir Abdelhafidh, University of Tunis El Manar, Tunisia
Rute Abreu, Polytechnic Institute of Guarda, Portugal
Claudia Rosa Acevedo, Universidade de São Paulo, Brazil
Anne-Maria Aho, Seinäjoki University of Applied Sciences, Finland
Shaukat Ali, University of Wolverhampton, U.K.
Paulo Almeida, Polytechnic Institute of Leiria, Portugal
Rui M. P. de Almeida, Polytechnic Institute of Lisbon, Portugal
Susana Almeida, Polytechnic Institute of Leiria, Portugal
Irina V. Alyoshina, State University of Management, Russia
Erhan Aslanoglu, Piri Reis University, Turkey
Tamer Mohamed Atef, Sultan Qaboos University, Qatar
Mohamed Karim Azib, University of Tunis El Manar, Tunisia
João Paulo Baía, Setúbal Polytechnic Institute, Portugal
Mário Simões Barata, Polytechnic Institute of Leiria, Portugal
Tania Silva Barboza, Pontifical Catholic University of Rio de Janeiro, Brazil
Alba Caicedo Barreth, University of Guayaquil, Ecuador
Sérgio Bastos, FUCEPE, Brazil
Liandi van den Berg, North-West University, South Africa
Rajendra P. Bhati, Lal Bahadur Shastri Institute of Management and Technology, India
Ann Blaya-Arena, Valmont Industries, U.S.A.
Herman Boikanyo, University of Johannesburg, South Africa
Gordon Bowen, Regent's University London, U.K.
Jorge Brantes, Pontifical Catholic University of Rio de Janeiro, Brazil
Francisco Carreira, Polytechnic Institute of Setúbal, Portugal
Alexandra Cristina Pinheiro Carvalho, Polytechnic Institute of Leiria, Portugal
Catia Marques Cebola, Polytechnic Institute of Leiria, Portugal
Vincent Chen, Cornerstone Consulting International, China
Lynsie Chew, University College London, U.K.
Elizabeth Chinomona, Vaal University of Technology, South Africa
Pawan Kumar Chugan, Nirma University, India
Mona Chung, Deakin University, Australia
Elsabe Conradie, CMS Council for Medical Schemes, South Africa
Magali Pedro Costa, Polytechnic Institute of Leiria, Portugal

Teresinha Covas, UNIP, Brazil
Sérgio Cruz, Aveiro University, Portugal
Dhouha Doghri, University of Manouba, Tunisia
Bongazana Dondolo, Tshwane University of Technology, South Africa
Đurđana Ozretić Došen, University of Zagreb, Croatia
Zenzo Lusaba Dube, National University of Science & Technology, Zimbabwe
Joseph Kuyamba Dzanja, LUANAR, Malawi
Richard Farr, University of Bolton, U.K.
Lígia Catarina Marques Febra, Polytechnic Institute of Leiria, Portugal
Maria Eduarda da Silva Teixeira Fernandes, Polytechnic Institute of Leiria, Portugal
Vitor Hugo Ferreira, Polytechnic Institute of Leiria, Portugal
Nikolay Filinov, National Research University Higher School of Economics, Russia
Afifa Hariz Frikha, ISET Charguia, Tunisia
Geoffrey Gachino, University of Dubai, U.A.E.
Brigita Gajšek, University of Maribor, Slovenia
Maher Gassab, University of Manouba, Tunisia
G. Gbadamosi, Bournemouth University, U.K.
Geoff A. Goldman, University of Johannesburg, South Africa
Conceição Gomes, Polytechnic Institute of Leiria, Portugal
Victor Gumbo, National University of Science and Technology NUST, Bulawayo
Ismail Haddad, Université de Carthage, Tunisia
Liz Heyworth-Thomas, University of Wolverhampton, U.K.
Reann Immelman, Barclays Africa (Absa Group), South Africa
Mezghani Ines, ISET COM, Tunisia
Yana Inzhivotkina, University of Guayaquil Campus FACSO
Varsha Jain, MICA, India
Tirlok Kumar Jain, Manipal University, India
Olumide Jaiyeoba, Limkokwing University of Creative Technology, Botswana
Frederic Jallat, ESCP Europe, France
Rim Jallouli, University of Manouba, Tunisia
Miroslaw Jarosinski, Warsaw School of Economics, Poland
Sanna Joensuu, Seinäjoki University, Finland
Bongani Khumalo, Tshwane University of Technology, South Africa
Olle Klasson, Stratwise Management Consulting, Sweden
Lillian Klasson, Stratwise Management Consulting, Sweden
Carina Kleynhans, Tshwane University of Technology, South Africa
Stephen Ko, Hong Kong Polytechnic University, China

Georg Kodydek, Vienna University of Economics and Business, Austria
 Monika Koller, Vienna University of Economics and Business, Austria
 Sergey V. Koloskov, Bauman Moscow State Technical University, Russia
 Jurij Kovac, University Maribor, Slovenia
 Edmir Kuazaqui, Universidade Presbiteriana Mackenzie, Brazil
 Yasuhiko Kubo, Sagami Women's University, Japan
 Manoj Kumar, Maharshi Dayanand Saraswati University, India
 Ana Lambelho, Polytechnic Institute of Leiria, Portugal
 Taiguara de Freitas Langrafe, Fundação Escola de Comércio Álvares Penteado, Brazil
 Gerald Ledlow, UTHEALTH Northeast, U.S.A.
 Auke Leen, Leiden University, Netherlands
 Vanessa León León, Florida International University, U.S.A.
 Inês Lisboa, Polytechnic Institute of Leiria, Portugal
 Alvaro Ferreira Lisboa Junior, John Kennedy University, Brazil
 Victor Lu, St. John's University, U.S.A.
 Eugénio Pereira Lucas, Polytechnic Institute of Leiria, Portugal
 Clifford Mabhena, National University of Science and Technology NUST, Zimbabwe
 Joana César Machado, Universidade Católica Portuguesa, Portugal
 Sheri L. Mackey, Luminosity Global Consulting Group, U.S.A.
 Stephen W. Mackey, University of Southern California Dornsife, U.S.A.
 Daniel K. Maduku, University of Johannesburg, South Africa
 Mohammed Mahdi, University of Wolverhampton Business School, U.K.
 Vincent Maher, Iona College, U.S.A.
 K.M. Makhitha, University of South Africa, South Africa
 Matjaž Maletič, University of Maribor, Slovenia
 Antonio Vico Mañas, Pontifícia Universidade Católica de São Paulo, Brazil
 Miha Marič, University of Maribor, Slovenia
 Susana Henriques Marques, ISCTE - Lisbon University Institute, Portugal
 Jose Luis Pereira Martins, Polytechnic Institute of Leiria, Portugal
 Miguel Martins, University of Johannesburg, South Africa
 Bruno Mascitelli, Swinburne University of Technology, Australia
 Ken Mathu, University of Pretoria, South Africa
 Rose Matikiti, University of Johannesburg, South Africa
 Noluthando S. Matsiliza, Cape Peninsula University of Technology, South Africa
 Victoria Matthews, Matthews & More Ltd., U.K.
 Lord Mensah, University of Ghana, Ghana
 Lurdes Mesquita, Polytechnic Institute of Cávado, Portugal

Paolo Miranda, Purdue University Northwest, U.S.A.
Thabang Mofokeng, University of Johannesburg, South Africa
Ingrid Mokgobu, Tshwane University of Technology, South Africa
Aubrey Mokoena, Vaal University of Technology, South Africa
Michael Mokoena, Tshwane University of Technology, South Africa
Genesis Thabo Molepo, Tshwane University of Technology, South Africa
Thabiso Morodi, Tshwane University of Technology, South Africa
Samir R. Moussalli, Huntingdon College, U.S.A.
Mercy Mpinganjira, University of Johannesburg, South Africa
Sylvia Mudau, Tshwane University of Technology, South Africa
Barbara Mueller, Johannes Kepler Universitat Linz, Austria
Stanley Mukhola, Tshwane University of Technology, South Africa
Zlatko Nedelko, University of Maribor, Slovenia
Bethuel Sibongiseni Ngcamu, Cape Peninsula University of Technology, South Africa
Hester Nienaber, University of South Africa, South Africa
Cecile Nieuwenhuizen, University of Johannesburg, South Africa
Nityesh Bhatt, Nirma University, India
Peter Nkala, National University of Science & Technology, Zimbabwe
Pat Obi, Purdue University Northwest, U.S.A.
Henrique Fernandes Pacheco, Pontifical Catholic University of Rio de Janeiro, Brazil
Pramod Paliwal, Pandit Deendayal Petroleum University, India
Nilam Panchal, Gujarat University, India
Fabio de Oliveira Paula, Pontifical Catholic University of Rio de Janeiro, Brazil
Olga M. Pisareva, State University of Management, Russia
David Pooe, University of Johannesburg, South Africa
M. Potgieter, NWU Potchefstroom, South Africa
George V. Priovolos, Iona College, U.S.A.
Anna Putnová, Brno University of Technology, Czech Republic
Carla Ricaurte Quijano, ESPOL, Ecuador
Colin Reddy, University of Johannesburg, South Africa
Maria Reznakova, Brno University of Technology, Czech Republic
Mornay Roberts-Lombard, University of Johannesburg, South Africa
Susana Rodrigues, Polytechnic Institute of Leiria, Portugal
A.T. Roux, Tshwane University of Technology, South Africa
Rudi Rozman, University of Ljubljana, Slovenia
Alejandro Chanabá Ruiz, FIMCBOR, Ecuador
Rosebud Rundora, Vaal University of Technology, South Africa

A.A. Rust, CPUT, South Africa
Cristina Isabel Branco de Sá, Polytechnic Institute of Leiria, Portugal
Zahra Salimi, University of Bolton, U.K.
Luis Lima Santos, Polytechnic Institute of Leiria, Portugal
Yohei Sasakawa, Fukuoka University, Japan
Chris Schachtebeck, University of Johannesburg, South Africa
Arnold Schuh, Wirtschaftsuniversität Wien, Austria
Christina Schweikert, St. John's University, U.S.A.
Neha Sharma, NIT Graduate School of Management, India
Kirsty-Lee Sharp, Vaal University of Technology, South Africa
Mabutho Sibanda, University of KwaZulu Natal, South Africa
Paula Marisa Nunes Simões, Polytechnic Institute of Leiria, Portugal
Pedro Manuel Rodrigues Carreira, Polytechnic Institute of Leiria, Portugal
Ivan A. Smarzhevskiy, RUDN-University, Russia
Vanessa Brulon Soares, Universidade Federal do Rio de Janeiro, Brazil
Filipe Augusto Silveira de Souza, Pontifical Catholic University of Rio de Janeiro, Brazil
Deepak Srivastava, Nirma University, India
Miklós Stocker, Corvinus University of Budapest, Hungary
Maria A. Strenina, RUDN-University, Russia
Sona L. Sumbatyan, State University of Management, Russia
A. K. Singh Suryavanshi, Chandigarh University, India
Rajhi Mohamed Tahar, University of Tunis El Manar, Tunisia
M. Tait, NMMU, South Africa
Mohamed Anis Bach Tobji, University of Manouba, Tunisia
Harismita Trivedi, Nirma University, India
Irene Troccoli, Estacio, Brazil
Anmari Viljamaa, Seinäjoki University of Applied Sciences, Finland
Marius Wait, University of Johannesburg, South Africa
Christoph Winkler, Long Island University, U.S.A.
Sudhir Yadav, Pandit Deendayal Petroleum University, India
Prithvi Yadav, Narsee Monjee Institute of Management, India
Ayse Yuce, Ryerson University, Canada
Oleg N. Zhilkin, People's Friendship University of Russia, Russia
Anna N. Zhilkina, State University of Management, Russia
Whitehead Zikhali, National University of Science and Technology NUST, Zimbabwe
Ondrej Zizlavsky, Brno University of Technology, Czech Republic
Deborah Zouain, Getulio Vargas Foundation

TABLE OF CONTENTS

Author(s)	Title	Page
Mag. Aneliya Adzhemova	Implications of Country Risks Changes on Market Cultivation Strategies: A Study Based On Austrian Companies With Subsidiaries in The Russian Federation	1
Dominic Appiah, Wilson Ozuem, & Kerry E. Howell	Brand Switching in the Smartphone Industry: A Preliminary Study	8
Samuel Ayertey & Wilson Ozuem	Linking Service Failures to Customer Satisfactions	16
Nicolene Barkhuizen, Nico Schutte & Leonie Nagel	Talent Management, Organisational Satisfaction and Turnover Intentions of Academic Staff	22
Alba Caicedo Barreth, Alba Barreth González, & Alex Franco Rodríguez	Communication for Tourism Development in Communities: A Case Study in Puna Island	31
Ayesha L. Bevan-Dye	Cosmopolitanism Versus Ethnic Identity Amongst South African Generation Y Students	39
Ayesha L. Bevan-Dye	Addressing the Ambiguity Surrounding Contemporary Generational Measurement Parameters	47
Nidhi S. Bisht	Job Stressors And Burnout in Field Officers of Microfinance Institutions in India: Role of Work-Related Rumination	54
D.A.J. Bornman	Flipping Innovative Teaching and Learning on its Head: A Hybrid Model for Undergraduate Business Management Education at South African University	65
Amani Boussaada & Fatma Siala Guermazi	Performance of Business Model of Banks: Identification and Analysis	73
Maleka Mogotsi Caiphus	Good Governance in Local Government: A South African Perspective	80
Mei-Ju Chen	Effects of Emotions Expression of Online Reviewer on the Perceived Helpfulness of Review Readers: From an Aggregative Perspective of Theory	87
Norman Chiliya, Cecile Nieuwenhuizen, & Darelle Groenewald	The Role of Government In The Implementation Of Sustainable Development Initiatives By Adventure Tourism SMMES In South Africa: An Exploratory Inquiry	96
Sulin Chung	The Role of Government in the Implementation of Sustainable Development Initiatives by Adventure Tourism Embedding the Convenience Store Business in a Changing Chinese Market: A Case Study of Familymart	105

Mona Chung & Bruno Mascitelli	Chinese Migration to Australia: From Discrimination to Business Investors?	111
Mark Cwiek, George Kikano, Jacob Klaus, Marcia Novaretti, & Drew Weil	Critical Steps Taken in the United States, Brazil and Around the World to Improve Patient Safety: Global Implications for Hospitals and Medical Organizations	120
Jessica Day, Reaan Immelman, & Mornay Roberts-Lombard	Choice Factors of Restaurant Patrons in the Marketing of Restaurants in South Africa	117
Hélène Delerue & Hélène Sicotte	Marginal Analysis of Project Resource Slack on Risks Perception	134
Hilda Bongazana Dondolo, & Nkosivile Welcome Madinga	In-Store Shopping Cart Abandonment: An Exploratory Study	140
Zenzo Lusaba Dube, Elias Muzinda, Ntobeko Ndlovu, Hilda Bongazana Dondolo, & Nkosivile Welcome Madinga	An Analysis of Enterprise Risk Management and Corporate Governance in Zimbabwe's Banking Sector	156
Koushik Dutta	Organizational Identity and Strategic Decisions in a Changing Business Environment	162
Nabila El jed, Kaouther Znaidi, & Chokri El Fidha	The Impact of Socio Professional Category of the Consumers on the Acceptance Level Towards Islamic Banking Window	172
Shandi Els, Mornay Roberts-Lombard, & Elsabe Conradie	Relationship Building Dimensions to Strengthen Customer Loyalty – An Islamic Banking Perspective	181
Hisao Fujimoto, Yuko Hayashi, & Yasuhiko Kubo	Purchasing-Consuming Cycle Model of Consumers and Retailers' Inventory Strategy	189
María J. García G., Gilberto J. Hernández G., & José G. Hernández R.	The Prime Numbers in the Kitchen	195
Dante Jorge Dorantes-Gonzalez	A Business Model Frame for Innovative Startups	204
Cookie M. Govender & Marius Wait	Managing Work Integrated Learning Strengths, Opportunities and Risks in the Emerging South African Environment	213
Palesa T. Gule & Daniel K. Maduku	Explaining Consumer Attitude Towards Purchasing Green Products: The Role of Knowledge, Self-Identity, and Utility	223
Tessie H H Herbst	Building Leadership Capacity in a University of Technology: 360-Degree Feedback as a Tool for Personal and Institutional Transformation	231
José G. Hernández R., Gilberto J. Hernández G., & María J. García G.	Some Sins in the Negotiations in Times of Industry 4.0: Soccer and Brexit	241
D. Frank Hsu & Xiaojie Lan	A Graph Model for Large and Heterogeneous Database Architectures	250

Suzaan Hughes & Chris Schachtebeck	Youth Entrepreneurial Intention in South Africa – A Systematic Review During Challenging Economic Times	260
Reaan Immelman & Mornay Roberts-Lombard	The Relevance of Information Sources in the Marketing of Independent Primary Schools in South Africa	269
Genius Katekwe	Developmental Challenges Faced by the Zimbabwean Economy: The Link to the Economy Structures	277
Khaled Kasseba	Oil Business Joint Ventures Performance Management Determinants-Towards a Conceptual Framework	286
Bongani Khumalo, Genesis Molepo, & Andile Mji	Managing Change Through Strategic Planning in South African Schools for Quality Improvement	301
Jessica Knight, Thina Mazibuko, & Geoff A Goldman	The Value of Corporate Social Responsibility for Beneficiaries: A South African Case Study	309
Moukita Koumba, John Francis Agwa-Ejon and Anup Pradhan	Environmental Implications of Artisanal Sandstone Mining: A Case Study of an Artisanal Sandstone Mine in Qwaqwa South Africa	318
Vladimir K. Krylov & Anna N. Zhilkina	Anti-Crisis Monetary Policy and Deflation	327
Marcia Lebambo & Richard Shambare	Entrepreneurship Policies Versus Practice: A Great Divide for Tourism Establishments in Rural South Africa	330
Auke R. Leen	The Austrian Case for a Consumption Tax to Finance the European Union	338
Anita Lennox	Managing Organised Sport: Are Alterations to School Sport Values Necessary?	346
Anita Lennox & Fanie Roos	Preparing Students for the Workplace – Development of Soft Skills	354
Tatiana Leonova & Galina Plotnikova	Cluster Approach to Innovation Policy: Russian Experience	361
Frank Paul Le Veness	Puerto Rico: The Saga Continues	367
T. Diana L. van Aduard de Macedo-Soares, Rodrigo Oliveira da Silva, & Sérgio Augusto Pereira Bastos	Framework for Analysis of Corporate Political Strategies of Regulated Firms From a Relational and Ethical Perspective: Focus on the Brazilian Rail Freight Sector	374
Nelson Sizwe Madonsela, Kehinde Sobiyi, & Bhekisipho Twala	Competitive Business Intelligence and Analytics Systems: A Strategy for SMME Organizations	386
Daniel K. Maduku	The Impact of System Characteristics on Decision-Makers' Attitude Towards the Adoption of Mobile Marketing	394
Chengedzai Mafini, Welby Vandrys, & Loury-Okoumba	Green Supply Chain Management and Supply Chain Performance in Manufacturing Small and Medium Enterprises	402

Lucky Boy Tebogo Makhubedu, Eveth Nwobodo-Anyadiegwu, & Charles Mbohwa	The Effect of Human Capital Investment and Motivation on Miners' Productivity at a South African Platinum Mine	411
Lucky Boy Tebogo Makhubedu, Eveth Nwobodo-Anyadiegwu, & Charles Mbohwa	Employee Engagement in the Trade Union Federation(s) Versus Management Saga in the South African Mineral Exploration Industry	426
Kelebogile Makhuzeni & Nico Schutte	The Legal Side of Talent: Exploring the Factors Affecting the Effective Management of Dispute Resolutions in Selected South African Government Institutions	436
Rankhumise Edward Malatse & Botshe Andrew Ramabele	Assessing the Implementation of Corporate Social Responsibility Practices: Insights from Camden and Grootvlei Power Stations	443
Molefe Jonathan Maleka	Exploring the Relationship Between a Living Wage and Human Resources Outcomes: Evidence from Tshwane Marabastat Mall	453
Cátia Malheiros, Conceição Gomes, Luís Lima Santos, & Paula Cardoso	Are the Independent Hotels Identified with USALI?	461
Guilherme de Andrade Martins, Maria Fatima Ludovico de Almeida, & Rodrigo Flora Calili	A Fuzzy AHP-TOPSIS Model for the Assessment and Selection of Renewable Energy Technologies	470
Jamwell Maswanganyi	The Protection of an 'Employee' Whose Contract is Terminated before Commencement of Work in South African Law	485
Jamwell Maswanganyi	The Protection of Personal Information of Research Participants in Research Conducted Electronically	492
Ken Mathu	Cleaning South Africa's Coal Supply Chain	501
Raymond Matlala & Richard Shambare	Understanding the Influence of Black Tax on University Students' Entrepreneurial Intentions in South Africa	508
NS Matsiliza	Curriculum Reform as a Vehicle for Change in the Field of Public Administration	516
Deborah Mokgojwa, Nicolene Barkhuizen, & Nico Schutte	The Development of a Talent Risk Management Tool for Academics in South African Education Institutions	525
Matodzi Michael Mokoena, Mmakosha Ingrid Mokgobu & Murembiwa Stanley Mukhola	The Economic Effects of Hartbeespoort Dam Areas	532
Genesis Molepo, Bongani Khumalo & Andile Mji	Accountability Sessions After Quarterly Results Analysis: An Effective Strategy for Education Top Management and an Immense Task to Principals and Educators Alike	540
John Ntshaupe Molepo	Cities to Cities International Relations: A Case of the City of Tshwane Municipality	550

Oyewale Mayowa Morakinyo, Matlou Ingrid Mokgobu, & Murembiwa Stanley Mukhola	Particulate Matter in Pretoria West, South Africa: Levels and Potential Risks for Human Health	558
Mercy Mpinganjira	Antecedents of Citizens' Attitude Towards M-Government: An Empirical Investigation	563
Mercy Mpinganjira	The Influence of Perceived Shopping Value on Online Store Revisit Intentions	571
Re-an Müller	Brand Personality Scale Development – A Literature Analysis	579
Re-an Müller	The Prominence of Branding Through History and its Relevance To Modern Brands: A Literature Review	589
Thomas Thinandavha Munyai, Kgashane Stephen Nyakala, & Charles Mbohwa	Lean Six Sigma Model for Improving Productivity Rate of Steel Manufacturing SMES	601
Nyasha Muswera, Richard Shambare, & Liberty Maunzagona	The “Ubuntu” Entrepreneurship Paradigm: Evidence from South African Rural Indigenous Micro-Entrepreneurs	616
Makamu N.I	The State of Performance Management and Development System in the Selected South African National Government Departments	623
Vinessa Naidoo & Mbiere Francois Sakata	An Assessment of Supply Constraints within the Low Cost Housing Sector in Tshwane, South Africa	631
Takalani Nemarumane & Charles Mbohwa	Impact of Waste Management Techniques of Industrial Parks in South Africa	638
Takalani Nemarumane & Charles Mbohwa	Benefits of Implementing Eco-Industrial Parks in South Africa through Sustainable Design	647
Vânia Maria Lima Neves & Patrícia Amélia Tomei	The Effect of Global Mindset on Leadership Behavior	656
Hester Nienaber	Immediate Manager, Performance Evaluation and Employee Engagement: Game Changer for Organizational Performance?	665
Vikelwa Nomnga	Traditional Foods are Safe for Consumption: A Case Study in Nompumelelo Community, East London, Eastern Cape Province	677
Charanya Nopnukulvised, Laden Aldin, & Gordon Bowen	The Influence of Multichannel Shopping on Hedonic Shopping Value	686
Eveth Nwobodo-Anyadiegwu & Charles Mbohwa	Corporate Social Responsibility as Driver of Sustainable Development in Host Community	696
Eveth Nwobodo-Anyadiegwu, Charles Mbohwa, & Michael Mutingi	Application of Ishikawa Diagram for Analysis of Experiential Learning Program in Higher Education	707

Stephen Nyakala, Thomas Munyai, Andre Vermeulen, & Jan-Harm Pretorius	Implementation of Quality Assurance Practices and Effectiveness of Road Construction Industry: A Case of South African Local Municipalities	717
Adejoke C. Olufemi, Andile Mji, & Murembiwa S. Mukhola	Low Carbon Awareness Among Young Adults in South Africa: A Preliminary Study	732
Nadine Oosthuizen & Sandra Perks	A Framework of the Factors Necessary for Effective Online Mentoring as an E-Learning Tool	739
Burhan Ozkan & Wasiu Olayinka Fawole	Food Insecurity Risks Perception and Management Strategies Among Households: Implications for Zero Hunger Target in Nigeria	748
Kelebogile Paadi, Nicolene Barkhuizen & Sonia Swanepoel	Exploring Talent Indicators in Internship Programmes for Human Resources Management Graduates	755
Alexandra Palioura & Shaukat Ali	e-Marketing & e-WOM Strategies: Challenges for Greek Hoteliers in Zakynthos	764
Elena Patten & Wilson Ozuem	The Notion of Omni-Channel Retailing in the Fashion Industry	776
Sandra Perks & Jodé May	Workplace Strategies to Increase Environmental Awareness to Reduce Global Warming Effects	782
Clarice Breviglieri Porto & T. Diana L. van Aduard de Macedo-Soares	Analysis from an Institutional Perspective of Firm Alliance Portfolios' Implications for Innovation: Two Cases in Brazil's Automotive Sector	790
Anna Poulakas, Alon Yoeli, Sebastian Deossa, Caio Batista de Melo, D. Frank Hsu, Dawn Johnson Adams, Cesarina Javier, & Anita Vazquez Batisti	WATSHERE: A Watson Cognitive System to Navigate Social/Health Resources for Public Schools	806
Anup Pradhan & John Francis Agwa-Ejon	Effectiveness of the Online Library Database in the University: A Case Study of the University of Johannesburg Bunting Road Campus	817
Nesrine Zouaoui Rejeb, Chokri El Fidha, & Kaouther Zenaidi	A Conceptual Framework of Perceived Efficiency of CRM: Case of Mobile Phone Operators in Tunisia	825
Therese Roux	Tracking a Lion in the Jungle: Trends and Challenges in Outdoor Advertising Audience Measurement	834
Therese Roux, Sfiso Mahlangu and Thembeke Lebeso	Organising the Giant that Never Sleeps: Digital Out-Of-Home (DOOH) Advertising Classifications	842
Jael Gudiño Ruiz, Alba Caicedo Barreth, & Marlon Salazar	Incidence of Cultural Activities in Tourism for Designing Tourist Products in Guayaquil	851
Rosebud Rundora & Job Dubihlela	Usage Patterns of Activity-Based Costing and the Impeding Barriers to Adoption by Manufacturing SMES in Gauteng, South Africa	859

Pichita Sansuwan & Supeecha Panichpathom	Habit Formation to Support the Continuance Usage of Line Application	869
Caroline Satche & Emeka E Obioha	Knowledge, Attitudes, and Beliefs of South African Antiretroviral Care Receivers on HIV and AIDS	878
Musa Saurombe, Nicolene Barkhuizen, & Nico Schutte	Management Perspectives on a Talent Value Proposition for Academic Staff in a South African Higher Education Institution	886
Chris Schachtebeck & Lehana Thabane	Frequency of Applications of Systematic Reviews in Evidence Synthesis in Management Research: A Scoping Review of South African Practices	895
Kehinde Sobiyi, Nelson Sizwe Madonsela, & Bhekisipho Twala	Assessment of Employee Empowerment on Service Quality in South Africa	903
Sona Sumbatyan	The Role of the Tax System in the Development of Oil and Gas Complex	911
C. Synodinos	Validating a Green Purchase Behaviour Model Amongst African Generation Y Students	915
C. Synodinos, D.G. Price, & A.L. Bevan-Dye	Antecedents of Mobile Gaming Brand Loyalty Amongst South African Generation Y Students: Pilot Test Results	924
Chih-Ching Teng, Shih-Min Hsu, & Shan-Shan Cheng	Identifying Critical Ethical Issues in the Hospitality Workplace: The Employee Perspective	932
José Eduardo de Oliveira Trindade & Maria Fatima Ludovico de Almeida	Measurement and Evaluation of Innovative Capacity and Innovation Performance of Small and Medium-Sized Enterprises	937
Ndivhuho Tshisevhe	The Effects of Trade Union Security Arrangements in the Workplace: South African Perspective	949
Liandi van den Berg	Key Intelligence Topics of Sport Coaches: Where Should the Focus Be?	958
Liandi van den Berg	Are Volunteer Coaches Jeopardising Youth Sport Participation?	966
CM van der Bank	A Human Rights Perspective: Family Dispute Resolution in the African Social Order and the Relevance of Culture	974
Elina Varamäki, Juha Tall, Anmari Viljamaa, Anne-Maria Mäkelä, & Marko Matalamäki	Unsuccessful SME Business Transfers	983
Maria Estela Varua, Mathew Bright, & Margaret Moussa	Australian Knowledge Workers' Productivity: What Matters?	991
A. Vasilopoulos	Multivariate Regression: A Very Powerful Forecasting Method	1000

Marius Wait & Mariette Frazer	The Effectiveness of Board Game Learning as an Educational Tool in Employee Development	1009
Ying Wang, Xiaoqin He, & Nan Bi	An Exploratory Research Study on Uncivilized Behaviour Based on Mass Media Exposure: A Case Study of Chinese Outbound Tourists	1021
Varang Wiriyawit	Regime Switching of Monetary Policy and Detectability	1028
Zhenning Xu, D. Frank Hsu, Weihua Gan, Ting Geng, Christina Schweikert	Market Segmentation using Cluster Analysis and Combinatorial Fusion	1034
Oleg N. Zhilkin & Anna N. Zhilkina	Investments in Growing Economies and Investment Attractiveness of Regions	1044

IMPLICATIONS OF COUNTRY RISKS CHANGES ON MARKET CULTIVATION STRATEGIES: A STUDY BASED ON AUSTRIAN COMPANIES WITH SUBSIDIARIES IN THE RUSSIAN FEDERATION

Mag. Aneliya Adzhemova
Vienna University of Economics and Business, Austria

ABSTRACT

The aim of this research project is to illustrate the relationship between country risk changes over time and market cultivation strategies for internationalization activities, with a focus on subsidiaries. For getting more concrete, the central research question to be answered is what the consequences of the changes of the Russian country risk are for the business activities of Austrian companies with subsidiaries in the Russian Federation after a successfully realized market entry. A case study research will be carried out through the inclusion of company information gained, on the one hand, from the annual reports of the selected companies, and, on the other hand, from expert interviews. Thus, the present thesis links both cross-border dimensions and company-specific aspects.

Keywords: country risk, ratings, foreign direct investments, market cultivation strategies, Russia.

INTRODUCTION

The Russian Federation is characterized not only by remarkable geographical conditions, but also by particular economic, political, legal and socio-cultural characteristics. As a result, especially foreign investors are confronted with specific business conditions. The World Bank's Doing Business (see Endnote 1) reports show a positive development of the Russian business environment: According to the Ease of Doing Business Ranking (2015), in 2006, the Russian Federation was ranked 79th (p. 92), then from 2009 to 2012 120th (Doing Business 2009, 2008, p. 6; Doing Business 2012, 2011, p. 6.), and since then it has improved its position over and over again, currently being at rank 40 (Doing Business 2017, 2016, p. 7). However, for approximately two years the Russian Federation has been in a deep economic crisis. While domestic companies rely on protectionist measures by the state, foreign companies are trying to adapt to the continuously changing and increasingly risky business environment. Investment growth, which has been again reached after the last economic crisis in 2009, fell even more dramatically in March 2014 due to the economic sanctions imposed by the European Union (see Figure 1).

Figure 1: Austrian foreign direct investments to the russian federation (in millions of US dollars)

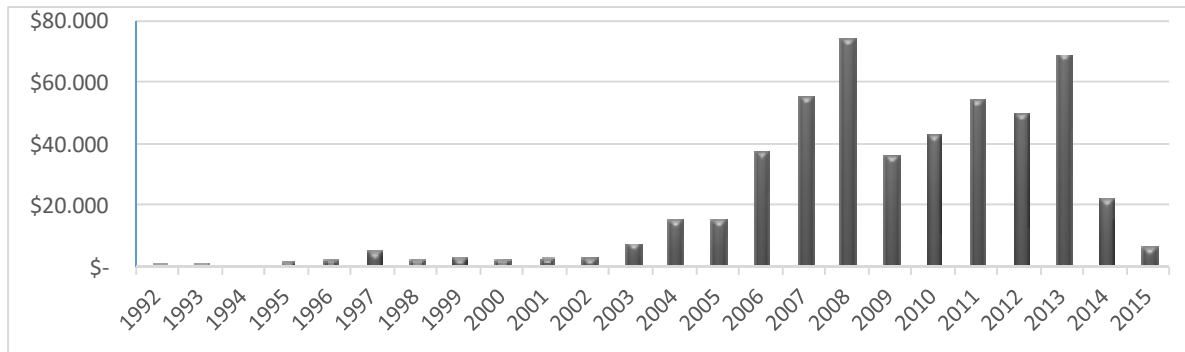

Source: <http://data.worldbank.org/indicator/BX.KLT.DINV.CD.WD?locations=RU>, World Bank, 2017.

Globally, after 2013, a sharp drop in the net foreign direct investment flows into the Russian Federation has been observed. For Austria, however, the Russian Federation has always been a favored business partner (see Endnote 2): hundreds of Austrian companies have ventured to enter the highly promising, but at the same time still highly controversial Russian market. Despite the well-known protectionist policy of the Russian government against foreign investors (see Endnote 3), many larger and smaller Austrian companies have ventured to enter the controversial Russian market through direct investment.

A view of the state of the Austrian FDI transactions in the Russian Federation reveals a persistent decline since 2011 (see Figure 2).

Figure 2: Austrian direct investment transactions to the russian federation (in millions of euros)

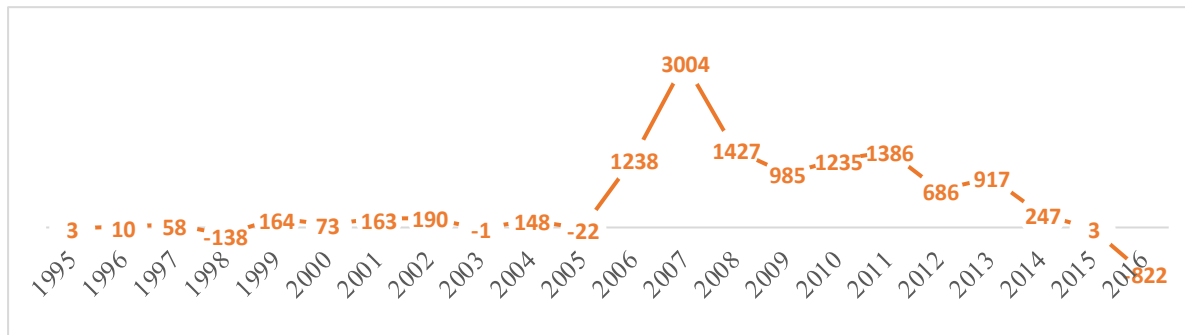

Source: <https://www.oenb.at/isaweb/report.do?lang=DE&report=9.3.02>, Austrian National Bank, 2017.

The statistical data of the Austrian National Bank are also confirmed by the World Bank data. According to those figures, after 2013, i.e. just before the Crimean conflict and the sanctions that followed, a massive decline in the level of FDI flows to the Russian Federation was to be observed: In 2013 FDI amounted to US\$ 69.22 billion, in 2014 fell to US \$ 22.03 billion and in 2015 - to US\$ 6.48 billion (The World Bank, 2015). The main causes for this ongoing decrease of the direct investment transactions from Austria to the Russian Federation in the last years are not only the well-known problems like extreme dependence on raw materials exports, lack of competitiveness of the manufacturing industry, a very high level of corruption, inefficient bureaucracy and a still continuing economic stagnation (Jänecke & Wehner, 2014, p. 2), but also, based on the Crimea-conflict, the still lasting sanctions from Western Europe. Based on these observations, the aim of this research project is to trace connections between subsequent changes in the country risk (ratings) of the Russian Federation and their influence on investment strategies regarding the market engagement of Austrian companies on the Russian market.

LITERATURE REVIEW AND RESEARCH QUESTION

Typically, country risk is interpreted as a generic term for the overall risk environment of a country, which leads to the delimitation of country risk in the broader sense from country risk in the narrow sense of *sovereign risk*. Based on that specification, *country risk* is associated with eventual negative impacts affecting companies' activities abroad that arise from the total economic, political and socio-cultural situation of the host country (Meyer, 1987, p. 16). In addition, the legal environment of the host country, potential global economic and environmental events are to be considered (Przybylski, 1993, p. 63), as well as various internal and external political tensions with neighboring countries or world powers and unions. Particularly in view of the recent clashes between Russia and the EU resulted in a number of sanctions, a special attention should be paid to the country risk's subcategory *political risk*. However, a synonymy of the generic term *country risk* and *political risk* as just one of its components should be avoided.

Empirical social research on the connection between risk and FDI rarely pays attention to the overall country risk. However, there are some exceptions like, for example, Blonigen (2005). Some of the studies concentrate on particular aspects like single components of country risk, for example, *political risk* (see Endnote 4); other study findings are often related to a specific region (see Endnote 5). There are also empirical works that investigate the influence of country risk *ratings* on FDI (Vijayakumar et al., 2009). Additionally, at the center of interest are often the initial motives for starting an internalization process and not the following decisions about the continuous presence at a certain foreign market. Consequently, the present doctoral thesis focuses on the exact implications of changes of the overall country risk on the conceptualized market cultivation strategies in this particular country case of Russia. In course of this research project, the following central research question has to be answered: *What impact do changes of the country risk of Russia have on market cultivation strategies of Austrian subsidiaries in Russia?*

METHODOLOGICAL APPROACH

Sampling

As stated in the introduction, Austria has always been an important partner for Russia. The concrete subjects of this research investigation are therefore Austrian companies with the strongest possible foreign representation in Russia, i.e. wholly-owned subsidiaries with Austrian capital participation up to 100%.

The main source of suitable companies was the homepage of the Vienna Stock Exchange because quoted companies have to publish their annual reports that provide a good data basis. The list has been also completed by own research work. Consequently, there has been selected a total of six companies having at least one sales office or/ and a production facility in the Russian Federation. In the next step, the chosen companies have been grouped in three industry sectors: financial institutions, infrastructure and mechanical engineering.

Research method

Due to the small sample of relevant Austrian companies with direct investments in Russia and the intention to carry out an in-depth analysis of the selected companies, the best research method turns out to be a *case study* method. Within this method, an individual case or a series of case studies are being described and investigated in detail (Flick, 2009, p. 177). Usually, the main idea is to find one or more solutions for a certain problem that a company is confronted with (Yin, 2003, p. 12). A major advantage of the case study method is the fact that the case is not isolated from the context, in contrast to an experiment, but it is being analyzed in its ordinary environment (Eisenhardt & Graebner, 2007, p. 25). Exactly this research strategy is pursued also in this dissertation.

Data collection

Secondary data

The secondary data that has to be obtained include, on the one hand, statistical FDI data from the Austrian National Bank as well as from the Central Bank of Russia. On the other hand, also vital for the realization of this research project are country risk ratings provided by different rating agencies. The third secondary source are annual reports of the selected Austrian companies from 2011 – three years before - to 2016 (published in 2017) – three years after the escalation of the conflict between Russia and Ukraine in March 2014. Relevant for the analysis are mainly two sections: risk management report and group management report.

Primary data

Based on the gained information from the insight into the company reports, there will be conducted expert interviews with the responsible persons for the business activities on the Russian market. Personal interviews are proved to provide much flexibility both in the process of data collection and the following analysis (Yeung, 1995, p. 313). This intention is planned to be realized both with representatives in the Austrian headquarters and with the respective persons directly in Russia. The second target group to be interviewed should not be underestimated, because these will be the people who have the chance to observe the occurring changes due to the volatile country risk on site and so give valuable, close to the market, information about the performance of the business operations in such a turbulent environment.

Figure 3: Phases of data collection

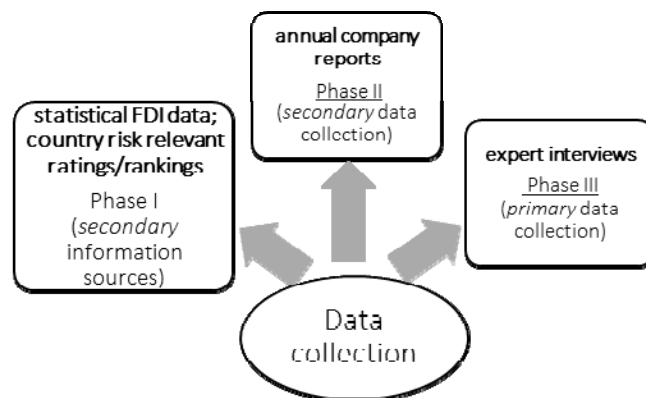

Data evaluation

Both the annual reports of the selected companies and the planned narrative interviews will be analyzed through the qualitative research method *document analysis*. The data of both information sources will be analyzed by using the software program for qualitative data analysis *Atlas.ti* (see Endnote 6).

EXPECTED RESULTS AND RESEARCH RELEVANCE

Looking at the interpretations of country risk in company reports, it turns out that there are no specific definitions of the term described. The most often used aspect is the political one, which could be easily explained by the recent geopolitical issues in Russia. These political instabilities, lately appearing as a result of the significant worsening of the bilateral relationship between Russia and the EU because of the Russia-Ukraine-conflict, are expected to have the most grave impact not only on the economic situation of the country, but also on the performance of the

subsidiaries of foreign companies there: financial losses, project postponements, staff cuts, closure of branches and other negative consequences for the business operations of foreign, including Austrian, subsidiaries on the Russian market. These and other concrete implications should be identified in the process of the planned research.

The main idea of this dissertation is to investigate the coherence between the development of market cultivation strategies at company level and the changing country risk for the selected country example. This doctoral thesis would, on the one hand, assist other (Austrian) companies that have already built subsidiaries in Russia with suggestions how to optimize their business operations there in difficult times. On the other hand, the results of this work will help other (Austrian) companies looking to enter the Russian market with FDI orienting regarding the selection of appropriate investment strategies in light of the actual country risk of Russia. And last but not least, this research makes an important and innovative contribution to the in-depth analysis of the effects of changes of the country risk (ratings) of one specific host country on the corporate performance of international companies there.

REFERENCES

- Aharoni, Y. (1966): The foreign investment decision process. In: *The Int. Exec.* 8 (4), 13–14.
- Astrov, V. (2009): Austria: relations with Russia and implications for the EU Eastern Partnership. In: Foti, G., Ludvig, Z. (Hg.): *EU-Russian relations and the Eastern Partnership: Central-East European member state interests and positions.* *East European Studies* (1). Budapest, 165–182.
- Austrian National Bank (2017): *Transaktionen Aktiver Direktinvestitionen nach Regionen. Regionale Zuordnung nach dem Sitz der ausländischen Tochter*, <https://www.oenb.at/isaweb/report.do?lang=DE&report=9.3.02>.
- Bennett, P. D.; Green, R. T. (1972): Political instability as a determinant of direct foreign investment. In: *The Int. Exec.* 14 (3), 20–21.
- Blonigen, B. A. (2005): A Review of the Empirical Literature on FDI Determinants. In: *Atl Econ J* 33 (4), 383–403.
- Brada, J. C.; Kutan, A. M.; Yigit, T. M. (2006): The effects of transition and political instability on foreign direct investment inflows. In: *Economics of Transition* 14 (4), 649–680.
- Chakrabarti, A. (2001): The determinants of foreign direct investments: Sensitivity analysis of cross-country regressions. *Kyklos* 54(1), 89-114.
- Click, R.W (2005): Financial and political risks in US direct foreign investment. *Journal of International Business Studies* 36, 559-575.
- Demirbag, M.; Tatoglu, E.; Glaister, Keith W. (2007): Factors influencing perceptions of performance. The case of western FDI in an emerging market. In: *International Business Review* 16 (3), 310–336.
- Doing Business in 2006 (2005): *Creating jobs.* The World Bank, 92.
- Doing Business 2009 (2008). The World Bank, 6.
- Doing Business 2012 (2011): *Doing Business in a More Transparent World.* The World Bank, 6.
- Doing Business 2017 (2016): *Equal Opportunity for All.* The World Bank, 7.

- Eisenhardt, K. M.; Graebner, M. E. (2007): Theory building from cases. Opportunities and challenges. In: *Academy of Management Journal* 50 (1), 25–32.
- Flick, U. (2009): *Qualitative Sozialforschung. Eine Einführung*, 7th ed., Reinbek bei Hamburg: rowohltts enzyklopädie.
- Friese, S. (2014): *Qualitative Data Analysis with Atlas.ti. Second Edition*. SAGE Publication. London.
- Goerzen, A.; Sapp, S.; Delios, A. (2010): Investor Response to Environmental Risk in Foreign Direct Investment. In: *Manag Int Rev* 50 (6), 683–708.
- Hayakawa, K., Kimura, F. & Lee, H. (2013): How Does Country Risk Matter for Foreign Direct Investment? *The Developing Economies, Vol. 51*, Issue 1, 60–78.
- Jänecke, B.; Wehner, W. (2014): *Russlandknigge. Praxisleitfaden für Geschäftsbeziehungen*. 4th ed. Berlin: De Gruyter Oldenbourg.
- Kobrin, S. J. (1976): The Environmental Determinants of Foreign Direct Manufacturing Investment. An Ex Post Empirical Analysis. In: *J Int Bus Stud* 7 (2), 29–42.
- Kobrin, S. J. (1978): When does political instability result in increased investment risk? In: *Columbia Journal of World Business* 13 (3), 113–122.
- Levis, M. (1979): Does political instability in developing countries affect foreign investment flow? An empirical examination. In: *Management International Review* 19 (3), 59–68.
- Meyer, M. (1987): *Die Beurteilung von Länderrisiken der internationalen*. Duncker & Humblot. Berlin.
- Przybylski, R. (1993): *Neuere Aspekte der Länderrisikobeurteilung internationaler Unternehmungen: eine Untersuchung unter besonderer Berücksichtigung der neuen politischen Ökonomie und des Einsatzes von KI-Technologien*. Kovač. Hamburg.
- Root, Franklin R.; Ahmed, A. A. (1979): Empirical Determinants of Manufacturing Direct Foreign Investment in Developing Countries. In: *Economic Development and Cultural Change* 27 (4), 751–767.
- The World Bank (2015): Data, Foreign direct investment, net inflows (BoP, current US\$), <http://data.worldbank.org/indicator/BX.KLT.DINV.CD.WD>.
- Vijayakumar, J., Rasheed, A. & Tondkar, R. (2009): Foreign Direct Investment and Evaluation of Country Risk: An Empirical Investigation. *Multinational Business Review, Vol. 17* (3), 181-203.
- World Bank (2017): Foreign direct investment, net inflows (BoP, current US\$): Russia, <http://data.worldbank.org/indicator/BX.KLT.DINV.CD.WD?locations=RU>.
- Yeung, H.W. (1995): Qualitative Personal Interviews in International Business Research: Some Lessons from a Study of Hong Kong Transnational Corporations. *International Business Review Vol. 4*, No. 3, 313-339.
- Yin, Robert K. (2003): *Case study research. Design and methods*. 3. Auflage. Thousand Oaks, California: SAGE.

ENDNOTES

¹ *Doing Business* presents quantitative indicators for business regulations in different countries. The *Ease of Doing Business Ranking*, for example, shows how easy it is to conduct a business in a certain country. The higher the ranking, the easier the business management.

² Historically, as the nearest Western European country, Austria has concluded the first long-term gas contract with the former Soviet Union already in 1968 (Astrov, 2009).

³ Further information can be found in the Federal Law "On foreign investments in the Russian Federation" (Федеральный закон "Об иностранных инвестициях в Российской Федерации") of 09.07.1999.

⁴ Aharoni (1966); Bennett & Green (1972); Kobrin (1976, 1978); Levis (1979); Root & Ahmad (1987); Chakrabarti (2001); Click (2005); Hayakawa, Kimura & Lee (2013)

⁵ Goerzen, Sapp & Delios (2010); Demirbag, Tatoglu & Glauster (2007); Brada, Kutan & Yigit (2006).

⁶ *Atlas.ti* is a German software program used primarily for qualitative analysis of text documents as well as images, videos and sound files. The name *ATLAS* is an acronym and stands for "Archiv für Technik, Lebenswelt, AlltagsSprache (Archive of Technology, Lifeworld and Everyday Language)" and the abbreviation *ti* at the end means text interpretation (Friese, 2014).

BRAND SWITCHING IN THE SMARTPHONE INDUSTRY: A PRELIMINARY STUDY

Dominic Appiah, University of Plymouth, United Kingdom
Wilson Ozuem, University of Gloucestershire, United Kingdom
Kerry E. Howell, University of Plymouth, United Kingdom

ABSTRACT

In recent years, the number of smartphone users has increased globally. The increase in choice and purchase intentions have enabled manufacturers to innovate new services that have created a competitive environment. This paper presents theoretical insight into the phenomenon of the brand switching behaviour of consumers in the smartphone industry, with implications for how resistance could be built from an identity theory perspective. Much emphasis has historically been placed on the functional utility of products at the expense of social meanings and with the expectation of product function, sufficient attention has been given to the socio psychological attributes, personal and social meanings of brands. The findings in this study include switching behaviours and organisational responses to contexts affecting the strategic actions and interactions. These comprise of the input of the concept of self-congruence, thus, how much a consumer's self-concept is congruent with the personality of a typical user of the brand. One way consumers achieve this is to consume brands that are congruent with one's own view of self, or ideal self. Consumers evaluate the symbolism of the brand and determine whether it is appropriate for their 'selves'.

Keywords: Brand Management, Brand Loyalty, Social mobility, Consumer Behaviour, identity theory.

INTRODUCTION AND BACKGROUND

In recent years, the number of smartphone users has increased globally. The smartphone is a type of multifunctional mobile phone that comes with applications such as mail, internet, calendar, notepads, and cameras in addition to telephone functionality. The greatest difference between smartphones and earlier multifunctional mobile phones is the fact that various applications can be added after the purchase of the device. Initially, mobile phone technology was used only for communication purposes. Later the inclusion of additional features created a greater market and modified the purchase behaviour of the customer when the evolution of the smart phone made a great impact on customer choice (Slawsby, Leibovitch, & Giusto, 2003). It is accepted that mobile phones are not desired purely for communication purposes but also for various features such as media support, Internet connectivity and special applications (Jones, 2002 and Hansen, 2003). Lately, smartphones have attracted the attention of all age groups from teenagers to pensioners and the special features both in terms of hardware (appearance and design) and software (applications and technology) influence choice.

Smartphones are radical innovative products which differ from normal mobile phones in terms of their additional features which are similar to miniature computers that provide various functions like built-in Operating Systems (OS), special software applications, multi-pixel camera or video features, music systems, internet connectivity and advancement in design and appearance. The increase in choice and purchase intentions have enabled manufacturers to innovate new services that have created a competitive environment. In this context multiple companies have introduced new smartphones, thereby gaining customer satisfaction and loyalty (Ganesan and Sridhar, 2014).

The dramatic growth in the usage of smartphones has attracted researchers and academics (Massoud and Gupta, 2003; Barnes and Scornavacca, 2004; Park and Yang, 2006) and special features in smartphones have created greater perception and expectations (Edell and Burke, 1987; Aaker, 1997). The features of the product are what the customer expects as a necessity. According to Nowlis and Simonson (1996) product features

generally attract customers and this leads to greater choice in choosing the products. Similarly Larivière and Van den Poel (2004) and Thompson et al (2005) stated that it is possible to attract new customers and retain existing customer by creating attractive features that result in customer's choice of choosing the product. In the context of smartphones, these features can include hardware or software components, whereby hardware is the tangible product defined by features, like colour, design, appearance, size and product weight, whereas software is an intangible attribute and includes programs, procedures and documentation which are purely based on operations. In general, the software of a smartphone is the operating platform and the apps that run the phone or the storage memory. The most important part of the smartphone is the operating system (OS), and OS manufacturers maintain a strong influence over the smartphone market. There are many software operating systems such as iOS (Apple), Android (Google), Windows (Microsoft), Symbian (Nokia) and RIM (Blackberry). Innovations in hardware and software have enabled growth in the smartphone market, since the multi-functional operations provided in products create a trust in technology that attracts the customer towards products. Trust in successful product features add ultimately brand recognition and this is the primary factor that affects intentions to purchase (Nah, Zhao & Zhu, 2003).

In a report by Kantar World panel Communications Technology, Apple in 2015 performed well, after new figures revealed its iOS operating system market share grew by 12% in the past year at the expense of rival Android, Apple's smartphone market share continues to grow across the UK, after consumers increasingly turn their backs on rival Android devices. The Californian Company achieved its highest ever share of Britain's smartphone market in the three months to October, 2014 after iPhones accounted for 39.5% of all sales. Now iPhones account for 42.5% of British sales - a growth of 12.2% year-on-year. Apple's growth comes at the expense of biggest rival Google's Android, whose UK share fell by 6.7% over the same period, according to data from Kantar World panel Communication Technology. Samsung in particular saw its market share decline across Europe and the US, while Apple now accounts for just under half of all US smartphone sales (47.4%), a 4.3% growth compared to the same period in 2013. The launch of iPhone 6 accounted for about one in five (19%) purchases in the three months to November 2014. As of November 2014, iOS accounted for 23.8% of smartphones in Britain, Germany, France, Italy and Spain; an increase of 6.3% compared to November 2013. Android's share, meanwhile, fell by 3.2 per cent from 69.9% in 2013 to 66.8% in 2014. Launched in September, 2014 the iPhone 6 and iPhone 6 plus have been key contributing factors to Apple's market share expansion.

THEORETICAL FRAMEWORK AND CONTEXTUALISATION

The plethora of research on brand switching covers customer motivations to review available alternatives in the market place due to changes in competitive activities, as a means to maximise functional utility product attributes and the marketing mix (Guadagni & Little 1983; Seiders & Tigerts, 1997; McFadden 1986). Nonetheless, the extant literature in the above stream of research fails to acknowledge the impact of socio psychological attributes besides functional utility maximization (Rao, Davis & Ward, 2000; Tajfel & Turner 1979; Ashok, Dillon & Yuan, 2002; Swait & Erdem 2007; Lam, Ahearne, Hu & Schillewaert, 2010; Oswald, 1999; Chaplin & John, 2005; de Chernatony & MacDonald, 1992). This paper presents a theoretical insight into the phenomenon of the brand switching behaviour of consumers in a competitive market with implications for how resistance could be built from an identity theory perspective.

As highlighted above, much emphasis has historically been placed on the functional utility of products at the expense of social meanings and with the expectation of product function, sufficient attention has been given to the socio psychological attributes, personal and social meanings of brands (Rao et al., 2000; Tajfel & Turner 1979; Ashok, Dillon & Yuan, 2002; Swait & Erdem 2007; Lam, Ahearne, Hu & Schillewaert, 2010; Oswald, 1999; Chaplin & John, 2005; de Chernatony & MacDonald, 1992). The basic assumption underlying this study is that people are constantly involved in social interactions and interpreting their constantly changing world. Hence this study deviates from the conventional economic perspective of treating brand switching as functional utility maximisation (Guadagni & Little 1983; Seiders & Tigerts, 1997; McFadden 1986), to treating brand switching as a consequence of social mobility between brand identities amongst consumers (Lam, Ahearne, Hu & Schillewaert, 2010).

First, the study explores existing literature on brand loyalty and identity theory to examine the effects of identity on customer loyalty. Despite extensive studies on brand loyalty (Anderson & Narus, 2004; Ozuem & Lancaster, 2012; Ozuem et al., 2016; Zeithaml, 1998), there has been little research on how market disruptions affect customer-brand-relationships and how firms can reposition themselves to sustain brand loyalty when disruptions occur in today's complex and globalised business environment (Lam, Ahearne, Hu & Schillewaert, 2010). Although the loyalty literature provides rich and useful insight into customer-brand relationships, two limitations warrant further investigation (Lam, Ahearne, Hu & Schillewaert, 2010).

1. Sustainability of brand loyalty predictors refers to resisting both time and market disruptions (*ibid*) however, the brand loyalty literature has mainly focused on how brands perform under normal market conditions (Keller & Lehmann, 2006). Yet as the business environment grows more complex and globalized, market disruptions become more prevalent.
2. Another limitation, arises when we consider the perceived value of brands when conceptualised and operationalized as functional utilitarian values. This is prevalent in the brand loyalty literature, which does not capture other non-utilitarian factors, such as socio psychological benefits, that might motivate customers to continue buying (e.g., Bagozzi 1975; Gardner & Levy 1955; Holbrook & Corfman 1985; Richins 1994; Sheth, Newman, & Gross, 1991; Solomon, 1983; Sweeney & Soutar 2001).

Secondly, this study builds upon the loyalty literature by considering the limitations identified above, to propose and develop a conceptual framework known as consumer-identification (CBI) model, in chapter four, to examine the issue of brand switching in a specific market disruption, namely the introduction of a radically new brand due to innovation in the technology industry and specifically the smartphone industry. The CBI model developed by Lam, Ahearne, Mullins, Hayati, & Schillewaert, (2013) is adapted and advanced for this study to support the antecedents of consumer identification in the Smartphone industry at a more matured and competitive stage. This sector was selected as the product category for this study because it represents a context in which brand switching is most likely to occur because of the multiple alternatives and short inter-purchase frequencies that identify it (Campo, Gijsbrechts & Nisol, 2000; Goldsmith, 2000). Notably, the market for smartphones is probably the most dynamic of any in the world, and the degree and rate of change in technology and product innovation disrupting the market is staggering (Azize, Hakan & Cemal, 2013).

Switching occurs when a customer is motivated to review their available alternatives in the market place due to a change in competitive activities in the market (Seiders & Tigerts, 1997). Economists view consumer choices as means to achieve maximization of functional utility (McFadden 1986). In addition, a common practice among marketing researchers is to model consumer brand switching as choices based on product attributes and the marketing mix (Guadagni & Little 1983). However, according to the original text on multi attribute utility theory (Lancaster 1966), consumer utility includes not only a brand's functional, but also its socio psychological attributes. Furthermore, McFadden (1986, p. 284), contends that it is necessary to incorporate psychometric data in choice models because these factors also shape the utility function. Surprisingly, it is not until recently that research on choice models has revived the need to incorporate softer, non-product related attributes, such as customers' attitudes and perceptions into models of brand choice and brand switching (Ashok, Dillon & Yuan, 2002; Swait & Erdem 2007). These researchers posit that such softer attributes also play an important role in predicting brand choice, and brand preference.

Following existing models of brand choice, "relative perceived value" is defined as the extent to which the utilitarian value of the functional benefits of a branded offering exceeds those of another alternative in the same product category (Lam, Ahearne, Hu & Schillewaert, 2010). When customers experience difficulty in generating positive information about their choice, they may infer that the amount of positive information is rather limited and may reverse their attitude towards the chosen brand (Wanke, Bohner, & Jurkowsch, 1997). With its relevance to functional utility, relative perceived value influences switching behaviour as functional utility maximization.

Brand switching as social mobility

In line with recent developments in choice modelling, social identity theory suggests that brand switching also serves socio psychological purposes besides functional utility maximization (Rao, Davis & Ward, 2000; Tajfel &

Turner 1979). This theory posits that people derive their identity from affiliations with social groups. They value such membership and distinguish themselves from those who do not share such affiliations, forming the in-group and the out-group. According to Lam et al., (2010), when a social identity is threatened, that is, negatively perceived in-group members will likely respond by resorting to three basic strategies: social mobility, social creativity, and social change. Social mobility refers to a person's attempt to leave or dissociate him or herself from the group, and moving from a lower-status group to a higher status one is an example (ibid). Social creativity describes a person's attempt to "seek positive distinctiveness for the in-group by redefining or altering the elements of the comparative situation" (Tajfel & Turner 1979, p. 43). For example, a business school that does not compare favourably with other schools in overall evaluation may seek out specific dimensions of comparison that grant it superiority over these other schools (Elsbach & Kramer 1996).

Finally, social change refers to direct competition with the out-group to retrieve higher status. In the marketing context, social change can be initiated either by competitors or by customers who identify with a brand. Market disruptions that are externally caused by competitors (e.g., radically innovative brands) can be viewed as attempts to initiate social change between competitors to vie for favour amongst customers. When a radically new brand is introduced, some customers may perceive it as having a more attractive identity than the incumbent's identity. From the customer's point of view, brand identifiers sometimes proactively generate negative word of mouth about brands that they do not identify with, especially after they are exposed to comparative advertising. From the identity theory perspective, the researcher proposes that customers may switch to a new brand for self-enhancement purposes to maximize socio psychological utility (e.g., symbolic benefits) rather than functional utility (e.g., functional benefits). In support of the social mobility argument, Rao, Davis, & Ward (2000) insist that firms migrate from the NASDAQ stock market to the New York Stock Exchange to preserve a positive identity.

In the marketing context, Stern, Thompson & Arnould, (1998) narrative analysis of marketing relationships implies that customers may switch to a brand they used to dislike by revising their view of the brand's identity and reference group. Research into cultural assimilation also reports that immigrants swap their cultural identities in consumption as they assimilate into the mainstream culture (Oswald 1999). Similarly, Chaplin and John (2005) suggest that, as children mature into adolescents, their self-concept becomes more sophisticated and so does their connections with brands. When the boundary between the in-group and the out-group is impermeable and changing group membership is not realistic, social mobility is not a viable strategy to cope with identity threats. For example, people rarely change their political affiliation, as social identity theory suggests that under such circumstances, people will engage in social creativity (Tajfel & Turner 1979). Tajfel & Turner (1979, p. 43) posit that social creativity can take multiple forms, such as (1) comparing the in-group with the out-group based on some new dimensions, (2) changing the values assigned to the attributes of the group such that previously negative comparisons are now cast in a positive light, and (3) avoiding using the high-status out-group as a comparative frame of reference. In other words, social creativity is a form of identity-based comparison that is based on in-group biases, and defined as a strong belief in the superiority of the group with which a person identifies. It is a form of prejudice against the non-identified group. Brewer (1979) posits that such in-group biases are both cognitive and motivational because these biases motivate in-group members (e.g., brand identifiers) to attend only to elements that the in-group will evaluate more positively than the out-group.

CONCLUSIONS AND MANAGERIAL IMPLICATIONS

Switching occurs when a customer is motivated to review available alternatives in a market place due to 'a change in competitive activity in the market place' (Seiders & Tigert, 1997). Hogan and Armstrong (2001) posited that brand switching is about replacing an incumbent resource with a more valuable one to achieve competitive advantage. Sathish, Kumar, Naveen, & Jeevanantham (2011) indicated that brand switching is a consumer behaviour where the behaviour of the consumers differs based on the satisfaction level of the consumers with providers or companies. Hence, brand switching can be described as the process of being loyal to one product or service, and switching to another due to dissatisfaction or any other problems.

The study discusses switching behaviours and organisational responses to contexts affecting the strategic actions and interactions. These comprise of the input of the concept of self-congruence. Self-congruity

refers to how much a consumer's self-concept is congruent with the personality of a typical user of the brand (Appiah, Ozuem & Howell, 2016). Brand personality is the set of human characteristics associated with a brand (Aaker 1997). Consumers tend towards those brands with similar personality traits to themselves. Individuals are driven by a need to feel good about themselves, and try to maintain, as well as enhance their own self-esteem (Malär, Krohmer, Hoyer, & Nyffenegger, 2011). One way towards achieving this is to consume brands that are congruent with one's own view of self, or ideal self (Sirgy 1982).

Indeed brands may be viewed as a system of signs in construction of the self (Schembri, Merrilees, & Kristiansen, 2010). Consumers evaluate the symbolism of the brand and determine whether it is appropriate for their 'selves' (Ahuvia 2005; Belk 1988; Schouten 1991). From the above arguments put forward, it can be said that shoppers re-purchase specific brands that carry meanings to them, as opposed to just the product utility (Appiah, 2015). Hence it can be argued that particular brands that possess distinctive identity have the potential to obtaining consumers attention and loyalty.

REFERENCES

- Aaker, D. A. (1995). "Building strong brands". New York: The Free Press
- Aaker J. (1997). Dimensions of Brand Personality. *Journal of Market Research*. 34: 347–56
- Albert, N., & Merunka, D. (2013). The role of Brand love in consumer-brand relationships. *Journal of Consumer Marketing*, 30, 258–266.
- Anderson, J. C., & Narus, J. A. (2004). *Business Market Management: Understanding, Creating, and Delivering Value*. Mahwah, NJ: Pearson Education.
- Appiah, D., Ozuem, W., & Howell, K. E. (2016). Towards A Sustainable Brand Loyalty: Attitudinal Loyalty Perspective. Global Business and Technology Association Conference. Dubai, U.A.E.
- Appiah, D. (2015). Building Brand Loyalty: Identity Theory Perspective. Role Competences and Responsibilities of Public Institutions on Generating New Scope towards European Integration. Seventh International Scientific Conference. Pristina, Albania
- Ashok, K., Dillon, W. R. & Yuan, S. (2002). "Extending Discrete Choice Models to Incorporate Attitudinal and Other Latent Variables," *Journal of Marketing Research*. 39 (February), 31–46.
- Azize, S., Hakan, K. & Cemal, Z. (2013). Creating Commitment, Trust and Satisfaction for a Brand: What is the Role of Switching Costs in Mobile Phone Market? *Procedia - Social and Behavioral Sciences*. 99 (2013) 496 – 502.
- Bagozzi, R. P. (1975). "Marketing as Exchange," *Journal of Marketing*. 39 (10), 32–39.
- Barnes, S. J. & Scornavacca, E. (2004). "Mobile marketing: the role of permission and acceptance", *International Journal of Mobile Communications*. Vol.2, No.2, pp. 128-139
- Belk, R. W. (1988). Possessions and the Extended Self. *Journal of Consumer Research*. 15 (September) 139-68.
- Campo, K., Gijbrecchts, E. & Nisol, P. (2000). Towards understanding consumer Response to Stock outs. *Journal of Retailing*. 76, 219–242.
- Chaplin, Lan Nguyen & Deborah Roedder John (2005). "The Development of Self-Brand Connections in Children and Adolescents," *Journal of Consumer Research*. 32 (1), 119–29.
- de Chernatony L. & MacDonnald, M. (1992). *Creating Powerful Brands*. Butterworth-Heinemann Ltd.

- Edell, J. A. & Burke, M. C. (1987), "The power of feelings in understanding advertising effects". *Journal of Consumer research*, Vol.14, No.3, pp.421-433.
- Gardner, B. B. & Levy J.S. (1955). The Product and the Brand, *Harvard Business Review*, 33 (March-April), 33-39.
- Ganesan & Sridhar (2014). Smart Phone Attributes, Choice and Brand Importance For Millennial Customer. *The Journal of Contemporary Management Research*, Vol.8 Issue No. 2, 71 - 89.
- Guadagni, Peter M. & D.C. J. Little (1983), "A Logit Model of Brand Choice Calibrated on Scanner Data: A Logit Model of Brand Choice Calibrated on Scanner Data," *Marketing Science*, 2 (3), 203–238.
- Goldsmith, R. E. (2000). Characteristics of the heavy user of fashionable clothing. *Journal of Marketing Theory and Practice*. 8, 21–28.
- Hansen, L. (2003). Service layer essential for future success. Ericsson Mobility World, General article, (June), available at: <http://www.ericsson.com>
- Holbrook, M. B. & Corfman, K. P. (1985). "Quality and Value in the Consumption Experience: Phaedrus Rides Again," in *Perceived Quality: How Consumers View Stores and Merchandise*, Jacob Jacoby and Jerry C. Olson, eds. Lanham, MD: Lexington Books, 31–57.
- Jones, S. (2002). "3G launch strategies, early adopters, why & how to make them yours". Tarifica report.
- Keller, K. L. & Donald R. Lehmann (2006), "Brands and Branding: Research Findings and Future Priorities," *Journal of Marketing Science*, 25 (6), 740–59.
- Lam, S. K., Ahearn M., Hu Y., & Schillewaert N. (2010), 'Resistance to Brand Switching When a Radically New Brand Is Introduced: A Social Identity Theory Perspective', *Journal of Marketing*, 74 (6), 128-46.
- Lam, S. K., Ahearne, M., Mullins, R., Hayati, B., and Schillewaert, N. (2013). Exploring the Dynamics of Antecedents to Consumer–Brand Identification with a New Brand. *Journal of the Academy of Marketing Science*, 41: 243-252.
- Lancaster, K. J. (1966). "A New Approach to Consumer Theory," *Journal of Political Economy*. 74 (2), 132–57.
- Larivière, B., & Van den Poel, D. (2004), "Investigating the Role of Product Features in Preventing Customer Churn, by using Survival Analysis and Choice Modelling: The Case of Financial Services", *Expert Systems with Applications*, Vol.27, No.2, pp. 277-285.
- Malär, L., Krohmer, H., Hoyer, W. D. & Nyffenegger, B. (2011), "Emotional Brand Attachment and Brand Personality: The Relative Importance of the Actual and the Ideal Self," *Journal of Marketing*, 75 (4), 35-52.
- Massoud, S., & Gupta, O. K. (2003), "Consumer perception and attitude toward mobile communication", *International Journal of Mobile Communications*, Vol.1, No.4, pp.390-408.
- McFadden, D. (1986), "The Choice Theory Approach to Market Research," *Journal of Marketing Science*, 5 (4), 275–97.
- Nah, F.F-H., Zhao, F. & Zhu, W. (2003), "Factors influencing users' adoption of mobile computing", in Mariga, J. (Ed.), *Managing E-commerce and Mobile Computing Technologies Book*, Idea Group Inc., Hershey, PA, pp. 260-71

- Nowlis, S. M., & Simonson, I. (1996), "The effect of new product features on brand choice", *Journal of Marketing Research*, Vol.33, No.1, pp.36-46.
- Oswald, L. R. (1999), "Culture Swapping: Consumption and the Ethnogenesis of Middle-Class Haitian Immigrants," *Journal of Consumer Research*, 25 (March), 303–318.
- Ozuem, W. & Lancaster, G. (2012). Technology-induced customer services in developing countries. In N. Delener (Ed.), *Service science research, strategy and innovation: Dynamic knowledge management methods* (pp. 185–201). Hershey, PA: IGI Global.
- Ozuem, W., Thomas, T and Lancaster, G. (2016). The Influence of Customer Loyalty on Small Island Economies: An Empirical and Exploratory Study. *Journal of Strategic Marketing*, 24 (6). Pp.447-469.
- Park, J. K. & Yang, S. (2006), "The moderating role of consumer trust and experiences: value driven usage of mobile technology", *International Journal of Mobile Marketing*, Vol.1, No.2, pp. 24-32
- Rao, H., Davis F. G., & Ward, A. (2000). "Embeddedness, Social Identity and Mobility: Why Firms Leave the NASDAQ and Join the New York Stock Exchange," *Administrative Science Quarterly*, 45 (2), 268–92.
- Richins, M. L. (1994). "Valuing Things: The Public and Private Meanings of Possessions," *Journal of Consumer Research*. 21 (10), 504–521.
- Sathish, M., Kumar, K.S., Naveen, K.J. and Jeevanantham, V. (2011). A Study on Consumer Switching Behaviour in Cellular Service Provider: A Study with reference to Chennai. *Far East Journal of Psychology and Business*, 2(2) 72
- Schembri, S., Merrilees, B. & Kristiansen, S. (2010). "Brand consumption and narrative of the self," *Journal of Psychology & Marketing*, 27 (6), 623-37.
- Seiders, K. & Tigert, D. J. (1997). Impact of Market Entry and Competitive structure on store switching/store loyalty. *International Review of Retail, Distribution & Consumer Research*. Vol. 7 Issue 3, p227-247.
- Schouten, J. W. (1991), "Selves in Transition: Symbolic Consumption in Personal Rites of Passage and Identity Reconstruction," *Journal of Consumer Research*, 17 (4), 412-25.
- Sheth, J. N., Newman, B. I. & Gross, B. L. (1991), "Why We Buy What We Buy: A Theory of Consumption Values," *Journal of Business Research*. 22 (2), 159–70.
- Sirgy M. J. (1982). "Self-Concept in Consumer Behaviour: A Critical Review," *Journal of Consumer Research*. 9 (3), 287-300.
- Slawsby, A., Leibovitch, A. M., & Giusto, R. (2003), "Worldwide mobile phone forecast and analysis, 20032007". IDC Report No.29586.
- Solomon, M. R. (1983). "The Role of Products as Social Stimuli: A Symbolic Interactionism Perspective," *Journal of Consumer Research*. 10 (10), 319–29.
- Stern, B. B., Thompson, J. C. and Arnould, E. J. (1998). "Narrative Analysis of a Marketing Relationship: The Consumer's Perspective". *Journal of Psychology and Marketing*, 15 (3), 195–214.
- Swait, J. & Erdem, T. (2007), "Brand Effects on Choice and Choice Set Formation Under Uncertainty," *Journal of Marketing Science*, 26 (5), 679–97.
- Sweeney, J. C. & Soutar, G. N. (2001). "Consumer Perceived Value: The Development of a Multiple Item Scale," *Journal of Retailing*. 77 (2), 203–220.

- Tajfel, H. & Turner, J.C. (1979). "The Social Identity Theory of Intergroup Behaviour", in *Psychology of Intergroup Relations*, Stephen Worchel and William G. Austin, eds. Chicargo: Nelson-Hall, 33-47
- Thompson, D. V., Hamilton, R. W., & Rust, R. T. (2005). "Feature fatigue: When product capabilities become too much of a good thing". *Journal of marketing research*, 42(4), 431-442.
- Wanke, M., Bohner, G. & Jurkowitsch, A. (1997). "There Are Many Reasons to Drive a BMW: Does Imagined Ease of Argument Generation Influence Attitudes?" *Journal of Consumer Research*, 24 (9), 170-177.
- Zeithaml V. A. (1988). Consumer Perceptions of Price, Quality and Value: A means-end Model and Synthesis of Evidence. *Journal of Marketing*. 52, pp 2-22.

LINKING SERVICE FAILURES TO CUSTOMER SATISFACTIONS

Samuel Ayertey, University of Plymouth, United Kingdom
Wilson Ozuem, University of Gloucestershire, United Kingdom

ABSTRACT

For businesses to resolve the matter of failures, it is critically important, therefore, to focus on developing levels of service, with particular reference to service recovery strategies. By contrast, however, in the online fashion industry, with no physical presence of service providers, and thus human interactions are minimal, service recovery strategies are more challenging. Service recovery is a crucial approach that can be utilised to help increase customer satisfaction, irrespective of business backgrounds, and the fashion industry is no exclusion. Drawing on current studies, this paper focuses on how effective recovery strategies for service failure can enhance the competitive position of organisations.

Keywords: Service failure, Service recovery, Fashion industry, Customer satisfaction, Customer switching behaviour.

INTRODUCTION

Over the past 30 years, fashion retailing, an innovative, dynamic and challenging industry has undergone immense changes, with the United Kingdom remaining at the forefront, and as a result is under considerable academic scrutiny (Doherty, 2000), particularly, but not exclusively, with reference to branding (Birtwistle and Freathy, 1998). Bhardwaj and Fairhurst, 2010 (among others) have recently studied consumer response to the fast fashion sector, which presents significant issues where its development is concerned. They assert that the fashion clothing industry has evolved significantly, principally during the last two decades (*ibid*). Christopher, Lowson, and Peck, (2004) identified problems with the way fashion is consumed and noted issues concerning quality and innovation, with the market becoming ever more demanding. This becomes evident in the demand for greater variety and more informed styles yet more economically priced than ever. (Ferne, Maniatakis and Christopher, 2009). In this connection, Doyle, Moore, and Morgan (2006) and Mollá-Descals, Frasquet-Deltoro and Ruiz-Molina (2011) noted the changes in the dynamics and increasing complexity of the fashion industry. Characteristics of such changes include a reduction in the requirements for manufacture in large quantities, and a larger number of fashion “seasons”. Other features include improved organisation of supply chains, leading businesses to opt for models that can be delivered flexibly and fast, and produced at low cost.

The internal and global importance of the U.K. fashion industry is underlined by London being among the top four world fashion centres, with Paris, New York and Milan (Jackson and Shaw, 2006). Jackson and Shaw (2006) particularly commented on London and Birmingham’s fundamental creativity and keenness in pursuing the latest trends, and on their being centres of luxury and fashion, attracting extensive traditional and virtual mass media, keen-eyed followers, enthusiasts and professionals. London Fashion Week, which takes place in February and September, is an example, as is the existence of the London College of Fashion. Topshop, a giant U.K. fashion concern, is of global significance. In terms of business, the fashion industry represents an important part of the national economy, with UK clothing and footwear sales reaching £48.55 billion in 2007 (Key Note, 2008).

According to a Mintel (2015) report online fashion accounted for £12.4bn consumption in the United Kingdom in 2015, representing a rise of over 15% as compared with the figure for 2014 (£10.7bn, while the U.K. trade in accessories accounted for £2.7bn, a 3.4 % increase over the figures for 2014. Oxford Economics

(produced by the British Fashion Council, 2016) published data showing significant increases in the UK fashion industry's contribution to the United Kingdom economy, rising by 22% from £21bn in 2009 to £26bn in 2014.

By definition, experience goods, for example clothing and footwear, are characterised by intangibility (Hassanein and Head, 2005) as well as difficulty in establishing the characteristics of the product (e.g. quality or price) until it has in fact been sold (Nelson, 1974; Weathers, Sharma and Wood, 2007). The absence of sales staff in online sales further complicates online service experiences, increasing the scope for service failures. Further important factors in this sense are the wide variety of merchandising mechanisms, demands by customers for online interactive assistance (which may also be psychological) from staff (Kunz, 2005). Yet the wide range of communication mechanisms and technology used by online marketers are requirements to stimulate the clientele to buy before they make their own individual evaluation of the product. Customers can, indeed, go to a physical store, a bricks-and-mortar establishment, to view the product for quality, size and fit, if the retailer is a large global concern. However, for pure-play fashion sellers this is not possible - the situation is not the same and represents a serious disadvantage: marketing visually is very difficult to achieve, and there is no direct contact with store staff. What this means is that, in order to compete with physical stores, pure-play online merchants must evolve perfect presentations of their products for their potential customers. In other words, a clear and thorough understanding of how different media affect customers' shopping experiences is essential.

THEORETICAL CONTEXT

Academics and practitioners have been focussing on online service failure and recovery strategies in particular since 2002 (Holloway and Beatty, 2003; Forbes, Kelly and Hoffman, 2005; Ozuem and Lancaster, 2014; Azemi and Ozuem, 2016). Complexity in this area has directed scholars of different disciplines to service recovery strategies, including the financial sector (Michel, 2001), online retailers (Wang, Wu, Sh., Lin, and Wang, 2011), restaurant services (Mattila, 1999), production and management services (Craighead, Karwan and Miller, 2004), business in general (Choi and Mattila, 2008; O'Keeffe, Ozuem and Lancaster, 2016; Ozuem, Limb & Lancaster, 2016), marketing (Sivakumar, Li and Dong, 2014), consumer behaviour (Argo, White and Dahl, 2006) and the service industry (Chuang, Cheng, Chang and Yang, 2012).

Additionally, research into online service failure and recovery strategies has succeeded in assigning meaning to online service failures and categorising them into many typologies (Forbes, Kelly and Hoffman, 2005; Kuo, Yen and Chen, 2011). Further attention has been given to the effects of online service failure and recovery strategies on lenses of traditional encounters' antecedents, with fewer antecedents in online failures being considered (Kuo, Yen and Chen, 2011; Wang, Wu, Sh., Lin, and Wang, 2011). Such epistemological orientations limit the potential and opportunities inherent in the selling of goods on the Internet (Ozuem, Howell & Lancaster, 2008). Understanding service inadequacy depends on individual expectations, so approaching the ontology of customers where failure and recovery processes are concerned should be contextual rather than generic or standardised. Lately, as identified by McColl-Kennedy and Sparks, (2003) and Tax, Brown, and Chandrasherakan, (1998) the justice and fairness theory has been of service in increasing the understanding of service failure and recovery. The principles of justice theory depend on equal fairness assessed from all parties in a society (Mandle, 2009). Meanwhile, Zhu, Nakata, Sivakumar, and Grewal (2013) sought to understand customer perceptions of what causes service failure (such as whether it is the customer's or the provider's fault).

Recovery Complexity

Different factors are assigned to the lacuna between customers and the provider when a failure arises. This begins with anonymous customer complaints which hinder providers who seek to comprehend customers' conceptualisations of the failure, leading the providers to view customers as "heterogeneous" (Sivakumar, Li, and Dong, 2014) in terms of their recovery strategy expectations. Similarly, Bougie, Pieters, and Zeelenberg (2003) contended that "most dissatisfied customers generally do not bother to complain" (p. 390), situating providers in a position where they do not comprehend the need to provide any recovery strategy. The issue appears to be even more complex in connection with online encounters. Scholars have undoubtedly enriched the service discipline although there is as yet no satisfactory definition of the service concept in terms of failure and recovery strategies. Whereas a majority of research has investigated service failure and recovery in conventional services (Ha and Jang, 2009; Shapiro *et al.*, 2006; Thwaites and Williams, 2006), the utilisation of the justice

theory for investigation of how customers respond in terms of their satisfaction after recovery, and their behavioural intentions in online settings has been scant. (Wang, Wu, Sh., Lin, and Wang, 2011). Empirical research on consumer perceptions of online service failure and recovery, however, is surprisingly scarce, despite the fact that service failures, both offline and online, are inevitable events for service firms. Crucially, online service failures can have a negative impact on profitability. Holloway and Beatty (2003) suggest that customers complain online more than offline. For consumers, the Internet offers a platform that makes complaining effortless yet impactful, where a wide and geographically dispersed audience can be reached. Compared with offline environments, switching is easier on the Internet since customers can browse and look for alternative providers with the click of a mouse. Given this background, gaining an understanding of how to manage online service failures effectively is essential to the success of firms operating in an online environment. Current research mainly concerns customers' reactions at brick-and-mortar outlets (i.e. offline) to service failure and recovery encounters, rather than in online encounters. Studies in this domain underline the importance of fair (or just) service recovery in restoring customer satisfaction following offline service failures (Smith, Bolton, & Wagner, 1999; Sparks & McColl-Kennedy, 2001; Roschk & Kaiser, 2013; Ozuem, Borrelli & Lancaster, 2017).

In earlier research into online service failures, Holloway and Beatty, (2003) noted that following recovery attempts by an online business, there is some feeling of injustice among customers, specifically related to the issues of interaction, distribution, and procedures cited by online clients. Yang and Young, (2009) affirm that purchasers of fashion are firmly convinced that the only way to buy is in a physical store (Mintel, 2009), since their inspiration is a response to their senses. The authors also assert that increasingly fashion e-businesses perceive the necessity of developing features for the online customer to interrelate with the product, thus attempting to remove or reduce the risks associated with purchasing fashion online. Cho and Workman, (2011) note that among the aspects that concern online customers are the appearance of the fashion item when worn, including with other items, and a range of information regarding the appeal of the item, and the appeal to the customers' senses. These imponderables are the root of concerns about the ability of retailers to be able to sell clothes online.

In this connection, a BBC report (2016) affirms that most online clothes shoppers send something back, thus suggesting that individuals like to feel and see garments before purchasing.

CONCLUSIONS AND MANAGERIAL IMPLICATIONS

With advances in modern information and communication technologies' (ICT) infrastructures have changed the way in which customer-firm interactions take place and services are delivered remarkably. Through the use of modern technology, services can be provided over long distances and without the physical presence of customers and employees (Schumann, Wunderlich and Wangenheim, 2012). Consumers are increasingly becoming familiar with online services and technology-mediated interactions, as they may offer the advantage of faster delivery, more convenient cost- and time-saving services than offline businesses. With the continued rapid development in the field of modern ICT, more and more services will be delivered by means of technology mediation. In the United Kingdom only, recent estimates show that 87% of consumers have Internet broadband connections at home and there are plans to make superfast broadband accessible to 95% of all households by 2017. When asked, 90% of consumers reported having shopped online in the previous three months (Mintel, 2015). In the online retail sector, especially sales of clothing and accessories are estimated to have reached the value of £10.7 billion in 2014, equivalent to more than 17% of the total spending on clothing and accessories. The Internet therefore provides unmatched opportunities for retail businesses.

Online retailers work with third parties, including logistics companies, to deliver their services and products to the customers. As this introduces yet another element into the chain of processes, it increases the likelihood of failures, such as delivery difficulties. In addition, the absence of an in-store sales assistant together with the sense of powerlessness caused by product uncertainty and low retailer visibility increases perceived risks associated with online purchasing. What this means is that in online sales there are likely to be more service failures as what is delivered fails to meet what the client expected, and more complaints, than in offline retailing. In this connection, a growing body of research has resulted from the increasing importance of the Internet in consumer purchasing decisions.

REFERENCES

- Argo, J. J., White, K., & Dahl, D. W. (2006). Social comparison theory and deception in the interpersonal exchange of consumption information. *The Journal of Consumer Research*, 33(1), 99–108. doi:10.1086/504140
- Azemi, Y., & Ozuem, W. (2015). Social media and SMEs in transition countries. In G. Bowen & W. Ozuem (Eds.), *Computer-mediated marketing strategies: social media and online brand communities* (pp. 114–133). Hershey, PA: IGI Global.
- BBC News (2016), available at: <http://www.bbc.co.uk/news/business-36395719>
- Bhardwaj, V. & Fairhurst, A. (2010) “Fast fashion: response to changes in the fashion industry”, *The International Review of Retail, Distribution and Consumer Research*, Vol. 20 No. 1, pp. 165-173.
- Birtwistle, G. & Freathey, P. (1998) “More than just a name above the shop: A comparison of the branding strategies of two UK fashion retailers”, *International Journal of Retail and Distribution Management*, Vol. 26 No. 8, pp. 318–23.
- British fashion council (2016) *The British Fashion Industry & London Fashion Week Facts & Figures. February 2016*, London, available at: www.britishfashioncouncil.co.uk.
- Bougie, R., Pieters, R., & Zeelenberg, M. (2003). Angry customers don't come back, they get back: The experience and behavioural implications of anger and dissatisfaction in services. *Journal of the Academy of Marketing Science*, 31(4), 377–393. doi:10.1177/0092070303254412.
- Cho, S. & Workman, J. (2011), “Gender, fashion innovativeness and opinion leadership, and need for touch: effects on multi-channel choice and touch/non-touch preference in clothing shopping”, *Journal of Fashion Marketing and Management*, Vol. 15 No. 3, pp. 363-82.
- Choi, S., & Mattila, A. S. (2008). Perceived controllability and service expectations: Influences on customer reactions following service failure. *Journal of Business Research*, 61(1), 24–30. doi:10.1016/j.jbusres.2006.05.006.
- Christopher, M., Lawson, R. & Peck, H. (2004) “Creating agile supply chains in the fashion industry”, *International Journal of Retail & Distribution Management*, Vol. 32 No. 8, pp. 367-76.
- Chuang, S. C., Cheng, Y. H., Chang, C. J. & Yang, S. W. (2012). "The effect of service failure types and service recovery on customer satisfaction: a mental accounting perspective." *The Service Industries Journal*. 32(2): 257–271.
- Craighead, C., Karwan, K. & Miller, J. (2004), "The effects of severity of failure and customer loyalty on service recovery strategies", *Production and Operations Management*, Vol. 13 No. 4, pp. 307-21.
- Doherty, A.M. (2000) “Factors Influencing International Retailers' Market Entry Mode Strategy: Qualitative Evidence from the UK Fashion Sector”, *Journal of Marketing Management*, Vol.16 No. 1, pp. 223-245.
- Doyle, S.A., Moore, C.M., & Morgan, L. (2006) “Supplier management in fast moving fashion retailing”, *Journal of Fashion Marketing and Management*, Vol. 10 No. 3, pp. 272-81.
- Fernie, J., Maniatakis, P.A., & Christopher, C.M. (2009) “The role of international hubs in a fashion retailer's sourcing strategy”, *The International Review of Retail, Distribution and Consumer Research*, Vol. 19 No. 4, pp. 421-436.

- Forbes, L. P., Kelly, S. W. & Hoffman, K. D. (2005) "Typologies of e-commerce retail failures and recovery strategies," *Journal of Service Marketing*, Vol. 19, No. 5, pp. 280-292.
- Ha, J., & Jang, S. S. (2009). Perceived justice in service recovery and behavioural intentions: The role of relationship quality. *International Journal of Hospitality Management*, 28(3), 319-327.
- Hassanein, K., & Head, M. (2005). The Impact of Infusing Social Presence in the Web Interface: An Investigation Across Different Products. *International Journal of Electronic Commerce* 10(2), 31-55.
- Holloway, B. B., & Beatty, S. E. (2003). Service failure in online retailing: A recovery opportunity. *Journal of Service Research*, 6(1), 92–105.
- Jackson, T., & Shaw, D. (2006). *The fashion handbook*. Oxon, UK: Routledge.
- Key Note (2008), *Clothing and Footwear Industry*, Key Note, London.
- Kunz, G. (2005), *Merchandising :Theory ,Principles, and Practice*, Fairchild, Books, New York, NY.
- Kuo, Y.-F., Yen, S.T. & Chen, L.H. (2011), "Online auction service failures in Taiwan: typologies and recovery strategies", *Electronic Commerce Research and Applications*, Vol. 10 No. 2, pp. 183-193.
- Mandle, J. (2009). *Rawls's a theory of justice: An introduction* (1st ed.). New York, NY: Cambridge University Press. doi:10.1017/CBO9780511814099.
- Mattila, A. (1999). An examination of factors affecting service recovery in a restaurant setting, *journal of Hospitality and Tourism Research*, Vol.23, No.3, pp.284-298.
- McColl-Kennedy, J.R .& Sparks, B.A. (2003) Application of fairness theory to service failures and service recovery. *Journal of Service Research*, 5(3), 251-266.
- Michel, S. (2001) "Analyzing service failures and recoveries: a process approach", *International Journal of Service Industry*, Vol. 12, No. 1, pp. 20-33.
- Mintel (2009) Ethical Clothing – UK – February 2009, Mintel, London.
- Mintel (2014), "Online Clothing Retailing", available at: <http://oxygen.mintel.com> (accessed 30 March 2016).
- Mintel (2015), "Online Grocery Retailing", available at: <http://oxygen.mintel.com> (accessed 30 April 2015).
- Mollá-Descals, A., Frasset-Deltoro, M., & Ruiz-Molina, M.E. (2011) "Internationalization patterns in fashion retail distribution: implications for firm results", *The Service Industries Journal*, First published on: 24 February 2011.
- Nelson, P. (1974), 'Advertising as information', *Journal of Political Economy*, Vol. 82, p.729-54.
- O'Keeffe, A., Ozuem, W., & Lancaster, G. (2016). Leadership Marketing: An exploratory study. *Journal of Strategic Marketing*. 24 (5), 418-443 doi:10.1080/0965254X.2014.1001867 .
- Ozuem, W., Howell, K. E., & Lancaster, G. (2008). Communicating in the new interactive marketplace. *European Journal of Marketing*, 42(9/10), 1059–1083. doi:10.1108/03090560810891145.
- Ozuem, W. & Lancaster, G. (2014). 'Recovery strategies in online service failure', in Ghorbani, A. (2014): *Marketing in the cyber era: Strategies and emerging trends*. Hershey, PA: IGL Global.

- Ozuem, W. Limb, N & Lancaster, G (2016) *Exploring the locus of internal marketing. Journal of Strategic Marketing*. pp. 1-17.
- Ozuem, W. Borrelli, M & Lancaster, G (2017) *Leveraging the co-evolution of offline and online video games: an empirical study. Journal of Strategic Marketing*, 25 (1). pp. 75-97.
- Roschk, H. & Kaiser, S. (2013). "The nature of an apology: An experimental study on how to apologise after a service failure." *Marketing Letters* 24: 293–309.
- Schumann, J.H., Wunderlich, N.V. & Wangenheim, F. (2012), "Technology mediation in service delivery: A new typology and an agenda for managers and academics", *Technovation*, Vol. 32 No. 2, pp. 133-143.
- Shapiro, T., Nieman-Gonder, J.M., Andreoli, N.A., & Trimarco-Beta, D. (2006) 'An Experimental Investigation of Justice-Based Service Recovery on Consumer Satisfaction, Loyalty, and Word-of-Mouth Intentions,' *Psychological Reports*, 99:3, pp. 864-878.
- Sivakumar, K., Li, M., & Dong, B. (2014). Service quality: The impact of frequency, timing, proximity, and sequence of failure and delights. *Journal of Marketing*, 78(1), 41–58. doi:10.1509/jm.12.0527.
- Smith, A. Bolton, R. & Wagner, J. (1999), "A model of customer satisfaction with service encounters involving failure and recovery", *Journal of Marketing Research*, Vol. 36 No. 3, pp. 356-372.
- Sparks, B.A. & McColl-Kennedy, J.R. (2001) "Justice Strategy options for increased customer satisfaction in a services recovery setting", *Journal of Business Research*, Vol. 54 No. 3, pp. 209-18.
- Tax, S.S., Brown, S.W., & Chandrasherakan, M. (1998) Customer evaluations of service complaint experiences: implication for relationship marketing. *Journal of Marketing*. 62(2), 60–76.
- Thwaites, E. & Williams, C. (2006) 'Service recovery: a naturalistic decision-making approach', *Managing Service Quality*, 16: 6, pp. 641 – 653.
- Wang, Y., Wu, Sh., Lin, H., & Wang, Y. (2011). The relationship of service failure severity, service recovery justice and perceived switching costs with customer loyalty in the context of e-tailing. *International Journal of Information Management*, 31(4), 350–359. doi:10.1016/j.ijinfomgt.2010.09.001.
- Weathers, D., Sharma, S., & Wood, S. L. (2007). "Effects of Online Communication Practices on Consumer Perceptions of Performance Uncertainty for Search and Experience Goods," *Journal of Retailing* (83:4), pp. 393-401.
- Yang, K. & Young, A.P. (2009), "The effects of customised site features on internet apparel shopping", *Journal of Fashion Marketing and Management*, Vol. 13 No. 1, pp. 128-39.
- Zhu, Z., Nakata, C., Sivakumar, K., & Grewal, D. (2013). Fix it or leave it? Customer recovery from self-service technology failures. *Journal of Retailing*, 89(1), 15–29. doi:10.1016/j.jretai.2012.10.004.

TALENT MANAGEMENT, ORGANISATIONAL SATISFACTION AND TURNOVER INTENTIONS OF ACADEMIC STAFF

Nicolene Barkhuizen and Nico Schutte
Global Innovative Forefront Talent Research Niche Area
North-West University, South Africa

Leonie Nagel
Department of Human Resource Management
Faculty of Economic and Management Sciences
University of Pretoria, South Africa

ABSTRACT

The main objective of this research was to explore the consequences of talent management on academic staff with reference to their satisfaction with talent management practices and turnover intentions. A quantitative research approach was followed with Talent Management questionnaires distributed to academic staff in South African higher education institutions (N=146). The results showed that academic experience a higher level of talent constraints compared to talent enablers. Signification relationships were found between Talent constraints, Talent Enablers, Satisfaction with institutional practices and funding and Turnover intentions of academic staff. Recommendations are made.

Keywords: Academics, Higher Education, Organisational Satisfaction, Talent Management, Turnover intentions

INTRODUCTION

Higher education institutions (HEIs) worldwide are facing significant challenges in attracting, retaining, and developing competent, innovative, and imaginative scholars for the future (Davies & Davies, 2010; Theron, Barkhuizen & Du Plessis, 2014). Colleges and universities will, sooner or later, have to acknowledge the importance, and perhaps paramount importance of employees as assets, and reflect this in the strategic plan or mission statement of the human resource department in order to attain lasting success (Saurombe, Barkhuizen & Schutte, 2017).

Universities with an established cadre of researchers with essentials skills and knowledge and who have development opportunities, already enjoy a competitive advantage over other HEIs. In this regard, South African HEIs might find it difficult to acquire and retain valuable talent for the following reasons:

- There is a decline in the supply chain, as less students enroll for certain courses (Mouton, 2010); and
- The 'brain drain' is causing a loss of talented academics to other countries (Ackers & Gill, 2005).
- A lack of a compelling higher educational brand to attract talented scholars (Saurombe, 2017)
- Increasing student demands and unrest (Badat, 2017)
- Poor compensation and reward practices (Onah & Anikwe, 2016)

High turnover intentions presents several challenges to higher education, such as the high cost of induction and training of new staff, loss of research outputs and subsequent organisational productivity, and reduced quality of teaching (Jain, 2013). Higher education management should therefore create a compelling talent value proposition to attract and retain talented academic staff members (Saurombe, 2017). The main objective of this research was to determine the interactive relationship between talent management, organizational satisfaction and turnover intentions of academic staff. Despite inroads made into the research of talent management, the application thereof in the higher educational context remains scarce. In addition, most research focus in individual level outcomes such as job satisfaction whilst neglecting organisation level outcomes such as organisation satisfaction which can be useful in explaining turnover intentions of employees.

This article is structured as follows. First a brief literature review is presented in the concept of talent management and its consequences for individuals and organisations. This is followed by a discussion of the research method adopted for this study, where after the results of the study are reported. This paper concludes with recommendations for practice.

LITERATURE REVIEW

Talent Management

Talent as a construct grew from personnel management, to human resources management, to human capital, and, ultimately, to the new field of talent management (Dries, Woekom & Meyers, 2013). Goff (2008) define talent as the right combination of inborn abilities, complemented by the knowledge, skills, attitudes (competence) and experience needed to perform in a given situation. Barkhuizen (2015) further states that talent should include the concepts of “willingness” and “self-belief”. Individuals are able to achieve their goals if they believe they can and are willing to do so. Bashabe (2010) has attempted to provide some clarity by attempting to define talent by taking a look at six perspectives of TM (Table 1). In addition, “national culture” is added as a seventh perspective as it is deemed integral to TM. The following table lists prominent definitions of talent management categorised in the workplace context

Table 1: Definitions of Talent Management

Perspective	Summary	Source
Process	TM should include all processes needed to optimise people within an organisation, and does not stand alone from other people management practices in an organisation, despite its talent-focused approach. Talent management is the implementation of integrated strategies or systems designed to increase workplace productivity by developing improved processes for attracting, developing, retaining and utilizing people with the required skills and aptitude to meet current and future business needs.	Garrow & Hirsch (2008) Welby-Cook (2010)
Organisational Culture	TM is a mindset to leverage the greatest competitive advantage from people while influencing and being influenced by the organisation's culture and values. This is achieved by individuals believing that their talent is needed for success.	Creelman (2004) Yarnall (2007)
HR planning	TM is about matching the right people to the right jobs at the right time, supported by highly sophisticated IT systems for effectiveness. Succession planning tends to be more prominent in companies taking this approach.	Capelli (2008)
Competition	TM is about identifying talented people and figuring out what they need so that competitors cannot poach them.	Woodruffe (2003)
Development paths	TM focuses on accelerated development of high-potential employees for future leadership deployment. Hence, the focus is on developing high potentials or talents much faster than others.	Blass (2007)

Change management	Change management is underpinned by the belief that TM is a driver of change in the organisation, using the talent management system as part of the wider strategic HR initiative for organisational change.	Lawler (2008)
National culture	TM is defined according to the different cultures (namely individualistic and collectivistic), which have different values about what a talent is and what kind of TM, or HRM practices in general, are appropriate. National culture has a great influence on TM and the way it is implemented in organisations.	Born and Heers (2009)

Consequences of Talent Management

A great deal of research has been devoted over the past decade to detect the outcomes of talent management for both the individual and the organisation. Studies in Sub-Saharan Africa found that talent management significantly increases positive work related outcomes of individuals such as: motivation, work engagement, organizational energy, employee performance, job satisfaction, productive organizational energy and service delivery (Barkhuizen, Mogwere & Schutte, 2014; Barkhuizen & Stanz, 2010; Barkhuizen, Schutte & Smit, 2015; Magolego, Barkhuizen & Lesenyeho, 2013). Other studies showed that the effective application of talent management can reduce incidences of burnout and ill-health (Molefi, 2015). Most studies to date show that talent management practices are significantly related either to the turnover intentions of employees (Barkhuizen, 2015).

Applied within the higher educational context Saurombe (2015) found that talent management practices such as talent acquisition, talent development, talent retention practices, performance management, workforce planning, staffing and management commitment had a significant impact on the meaningfulness and happiness of academics in their workplace. The same study showed that the availability of talent management practices reduces academics intention to quit their jobs. Theron, Barkhuizen and Du Plessis found that Management Support, Compensation and rewards and satisfaction with institutional practices (i.e. generational institutional practices; funding opportunities and diversity practices) significantly reduces academic staff's intention to quit their jobs. Lesenyeho, Barkhuizen and Schutte (2017) found that talent attraction practices (i.e. Job security; Autonomy; Innovation; Contribution; Career Advancement), Talent Development practices (i.e. Role Clarity; Skill unitization; Participation in Career Decisions), Compensation and recognition, Management support and Satisfaction with institutional practices enhanced the organizational commitment of early career academics and reduced their intention to quit the academic profession.

In the light of the preceding, the following hypotheses are set:

H 1: Talent Management would be significant positive related to the organizational satisfaction of academics

H 2: Talent Management would be significant negative related to turnover intentions of academics

H 3: Organisational satisfaction would be significant negative related to turnover intentions of academics

RESEARCH DESIGN

Research Approach

A quantitative research approach was followed. According to Maree (2010, p. 145), quantitative research is “A process that is systematic and objective in its ways of using numerical data from only a selected subgroup of a universe (or population) to generalise the findings to the universe that is being studied.” Quantitative research is done from a deductive approach, involving the testing of theoretical propositions by the employment of a research strategy that is specifically designed for the purpose of the testing (Saunders, Lewis & Thornhill, 2009). This, in essence, means that no new concepts will be developed, but that only something already proposed to be true in the literature will be tested.

Sampling

The sample included academic staff members from 11 South African higher education institutions. Of the 330 questionnaires that were distributed, 158 completed questionnaires were received, and only 146 were usable for data analyses. This represents a response rate of 44%. Most of the respondents in this study were male (40,4%), White (45%) and English speaking (36,9%). The participants were primarily aged 40 to 49 years (32,4%) in possession of a Masters Degree (41,3%) and employed as a Lecturer (40,6%). Most of the participants were focusing either on teaching and research (67,1%), employed between 0 to 10 years in their current institution (61,6%), and current position (89,4%). Most of the participants work more than 40 hours in a work week (64,8%).

Measuring Instruments

An adapted version of the Job Characteristics Inventory (Barkhuizen, 2005), adapted Organisational Satisfaction Scale (Theron et al., 2011) and Intention to Quit measure (Cohen, 2003) were used to gather the data.

Job characteristics inventory: The Job Characteristics Inventory was used to measure the academics' perceptions of the current application of TM practices in their respective HEIs. The Job Characteristics Inventory consists of 39 items, and measures eight TM practices: staffing, talent acquisition, talent deployment, management support and commitment, opportunities for career development, talent engagement, performance and remuneration. Respondents are requested to indicate their responses on a four-point Likert scale ranging from *Never* (1) to *Always* (4). The measure has been validated in previous studies (see Barkhuizen, 2005).

Organisational Satisfaction: This adapted questionnaire measures general satisfaction with 13 institutional practices, i.e. *Institutional leadership, Values, Strategies, Communication, Talent management* (nine items), and *Satisfaction with research funding* (four items). Responses are measured on a four-point Likert scale ranging from *Extremely dissatisfied* (1) to *Extremely satisfied* (4). This questionnaire obtained an acceptable internal consistency ranging from 0.783 to 0,923 (see Theron et al., 2014).

Intention to Quit Scale: The questionnaire consists of three items, and assesses academics' intention to leave. Responses are measured on a six-point Likert scale ranging from *Strongly disagree* (1) to *Strongly agree* (6). Acceptable internal consistencies were obtained of above 0,90 for this measurement in several South African studies (see Smit 2013).

Data analyses

Data analyses were carried out with the aid of SPSS software (SPSS, 2016). Exploratory factor analyses, descriptive statistics (i.e. means, standard deviation, skewness and kurtosis) were applied. Cronbach Alphas were used to determine the reliability of the scale and its items. A cut-off point of 0.7 was used as a guideline for acceptable reliabilities (Field, 2009). Pearson correlation analyses were performed to test for the significance of relationships between the variables. Manova analyses were used to test for significant differences in talent management of the respondents based on their demographic characteristics.

RESULTS

The descriptive statistics and reliabilities of the measurements are reported in Table 2 below:

Table 2: Descriptive statistics of the measurements

	Mean	Std. Deviation	Skewness	Kurtosis	Cronbach Alpha
TALENT MANAGEMENT PRACTICES					
Staffing	3.2352	0.6726	-0.529	-0.776	0.785
Talent Acquisition	2.9658	0.5450	0.102	-0.663	0.734
Talent Deployment	3.0918	0.5594	-0.365	0.138	0.759
Talent Development	3.0719	0.8094	-0.513	-0.590	0.818
Executive Support	3.2894	0.7232	-0.998	0.368	0.883
Performance	2.9623	0.6143	-0.161	-0.563	0.849
Talent Engagement	2.9274	0.6488	-0.343	0.014	0.824
Remuneration	2.0483	0.7432	0.594	-0.107	0.850
ORGANISATIONAL SATISFACTION					
General Practices	2.7602	0.53413	-0.139	0.834	0.904
Funding Opportunities	2.7293	0.59403	-0.461	0.656	0.779
TURNOVER INTENTIONS					
Intention to Quit	2.912	1.59154	0.53	-0.81	0.911

The results in Table 2 show acceptable to excellent reliabilities for the scales. The respondents indicated that talent management practices are applied most of the time. Almost half of the participants indicated a lack of adequate compensation. More than 60% of the respondents in this sample were satisfied with institutional talent management practices and funding opportunities. However almost half of the participants in this study considered quitting higher education institutions.

The correlation analyses between the Talent management, Organisational satisfaction and intention to quit are reported in the table 3 below.

Table 3: Pearson Correlations between Talent Management, Organisational Satisfaction and Turnover Intentions

	General Practices	Funding Opportunities	Intention to Quit
Staffing	-0,053	-0,063	0,101
	0,525	0,449	0,230
Talent Acquisition	-0,152	-0,138	-.248**
	0,068	0,098	0,003
Talent Deployment	.289**	0,097	-.217**
	0,000	0,244	0,009
Talent Development	.314**	.284**	-.309**
	0,000	0,001	0,000
Executive Support	.294**	.220**	-.283**
	0,000	0,008	0,001
	.311**	0,123	-0,155

Performance Management	0,000	0,142	0,063
Talent Engagement	.475**	.249**	-0,146
	0,000	0,003	0,080
Remuneration	.415**	.287**	-.406**
	0,000	0,000	0,000
Intention to Quit	-.417**	-.293**	1
	0,000	0,000	

* Statistically significant: $p \leq 0,01$

+ Practically significant correlation (medium effect): $r \geq 0,30$

++ Practically significant correlation (large effect): $r \geq 0,50$

The results in Table 3 show that Talent Deployment, Talent Development, Executive Support, Performance Management, Talent Management and Remuneration are significant positive related to Satisfaction with General practices. The effects for Talent development, Performance management, Talent engagement and remuneration are medium. The results further showed that Talent development, Executive support, Talent engagement and Remuneration are significant positive related to satisfaction with funding. Talent acquisition, Talent Deployment, Talent Development, Executive Support and Remuneration are significant negative related to intention to quit. The effects for Talent Development and Remuneration are medium. Intention to quit are significant negative related to Satisfaction with organisation practices (medium effect) and satisfaction with funding.

The above results partially confirm Hypothesis 1 and 2 that Talent management is significant positive related to Organisational satisfaction and significant negatively related to intention to quit. The above results further confirm hypothesis 3 that Organisational satisfaction is significant negative related to intention to quit.

MANOVA was performed to determine whether there are any significant differences in the academics' perceptions of the current TM practices, based on their demographic characteristics. A factor analyses were performed on the talent management practices to determine the Talent Demands (Mean = 3.0668; $\alpha = 0.832$) and Talent Enablers (Mean = 2.8984; $\alpha = 0.922$). The two factors explained 70.342% of the variance of the Talent Management Measure. The results of the MANOVA analyses are presented in Table 4.

Table 4: Manovas between Talent Management and Demographic Characteristics

	Wilks' Lambda Value	F	Hypothesis df	Error df	Sig.	Partial Eta Squared
Gender	0.977	1.590 ^b	2	137.000	.208	.023
Ethnicity	0.892	2.617 ^b	6	268.000	.018	.055
Home Language	0.873	4.780 ^b	4	272.000	.001	.066
Age	0.854	2.702 ^b	8	264.000	.007	.076
Qualifications	0.934	1.582 ^b	6	274.000	.152	.033
Job level	0.861	2.632 ^b	8	272.000	.009	.072
Job Category	0.979	.708 ^b	4	270.000	.587	.010
Years Institution	0.913	2.177 ^b	6	280.000	.045	.045
Years Current Job	0.996	.245 ^b	2	137.000	.783	.004
Hours Work	0.825	2.710 ^b	10	268.000	.003	.092

From the results shown in Table 4, it is evident that statistically significant differences exist only according to ethnicity, age, home language, job level, and the number of years at the institution. Results show no statistically significant differences according to gender, qualifications, job category, and number of years in current position. The results of the significant relationships between the biographical variables and Talent Demands and Talent Resources are reported below.

The Wilks's lambda value for ethnicity was equal to 0.892 [$F_{(6, 140)} = 2.617, p \leq 0.05$]. This implies that there is a significant difference between the mean scores of the groups relating to job level and Talent Constraints and Talent Enablers. Analysis of each dependent variable, using a Bonferroni adjusted alpha level of 0.025, showed that the job level groups differed in terms of Talent Constraints ($F_{(3, 1.327)} = 5.317, p \leq 0.05$, partial $\eta^2 = 0.106$). The results show that Coloured and White ethnic groups experience a higher level of Talent Constraints than the Black ethnic group. The effect was large.

The Wilks's lambda value for the age was equal to 0.854 [$F_{(8, 138)} = 2.702, p \leq 0.05$]. This implies that there is a significant difference between the mean scores of the groups relating to age and Talent Constraints and Talent Enablers. Analysis of each dependent variable, using a Bonferroni adjusted alpha level of 0.025, showed that groups differed in terms of Talent Constraints ($F_{(4, 1.262)} = 5.170, p \leq 0.05$, partial $\eta^2 = 0.135$) and Talent Enablers ($F_{(4, 0.110)} = 0.459, p \leq 0.05$, partial $\eta^2 = 0.014$). The results show that academics aged 30 to 39 years experienced higher levels of Talent Constraints than those aged 20 to 29 years. The effect for Talent Constraints was medium.

The Wilks's lambda value for job level is equal to 0.861 [$F_{(8, 138)} = 2.632, p \leq 0.05$]. This implies that there is a significant difference between the mean scores of the groups relating to job level and Talent Constraints and Talent Enablers. Analysis of each dependent variable, using a Bonferroni adjusted alpha level of 0.025, showed that the job level groups differed in terms of Talent Constraints ($F_{(4, 0.919)} = 3.532, p \leq 0.05$, partial $\eta^2 = 0.093$) and Talent Enablers ($F_{(4, 0.350)} = 1,500, p \leq 0.05$, partial $\eta^2 = 0.042$). The results show that associate professors experience a higher level of Talent Constraints than junior lecturers. The effect for Talent Constraints was medium.

The Wilks's lambda value for the number of years at the institution was equal to 0.913 [$F_{(6, 140)} = 2.177, p \leq 0.05$]. This implies that there is a significant difference between the mean scores of the groups relating to number of years at the institution and Talent Constraints and Talent Enablers. Analysis of each dependent variable, using a Bonferroni adjusted alpha level of 0.025, showed that groups differed in terms of Talent Constraints ($F_{(3, 1.047)} = 3.913, p \leq 0.05$, partial $\eta^2 = 0.077$). Results show that academics experience more Talent Constraints if they have been working for the HEI for between 11 and 20 years than for less than 10 years. The effect was small.

DISCUSSION AND CONCLUSIONS

The main objective of this research was to determine the interactive relationship between talent management, organizational satisfaction and turnover intentions of academic staff. The results showed that most of the talent management practices are applied except for remuneration. These results are in line with previous studies that highlighted the poor compensation of academic staff (Onah & Anikwe, 2016). The results further showed that the participants were satisfied with organizational practices and funding opportunities. Despite the availability of talent management practices, about half of the academics in this considered quitting their jobs.

From the correlation analyses it was evident that compensation and executive support plays a key role in the retention of academics (see Lesenyeho et al., 2017; Theron et al., 2014). The results also highlighted the importance of talent acquisition and person-job fit (talent deployment) in retaining academic staff members (Saurombe et al., 2017). More research is needed to identify the reasons for turnover intentions and differences in the perceived application of talent management of a diverse workforce.

This research had some limitations. First a cross-sectional research design was followed which limited the research in terms of cause and effect inferences that can be made over the longer term. Second the sample

only included academic staff members. The results of this research can therefore not be generalized to other contexts.

For future research it is recommended that a mixed method research approach be followed that can provide deeper insights into the quantitative results obtained in this study. The sample should also be expanded to include other stakeholders in the talent management process such as higher educational management and human resource practitioners.

This research has important practical implications for higher education institutions. The results revealed that higher educational management should focus on creating a work environment that enables the effective management of talent. As showed by the results of this study, the application of talent management has important consequences for both employees and the institution.

REFERENCES

Ackers, L. & Gill, B. (2005). Attracting and Retaining 'Early Career' researchers in English Higher Education Institutions. *Innovation*, 18 (3), 277-299.

Badat, S. (2017). Deciphering the meanings, and explaining the South African Higher Education student protests of 2015-6. Unpublished research paper.

Bashabe, M. (2010). *Defining talent management: A review of the South African literature*. Unpublished master's thesis. University of Johannesburg, Johannesburg.

Barkhuizen, E.N. (2005). Work wellness of academic staff in South African higher education institutions. Unpublished Doctorial Thesis: North-West University.

Barkhuizen, E.N. (2015, March). Talent Management: The catalyst for the 21st Century Business World. Unpublished Inaugural Lecture, North-West University, Mmabatho, South Africa.

Barkhuizen, E.N., Mogwere, P., & Schutte, N.E. (2014). Talent Management, Work Engagement and Service Quality Orientation of Support Staff in a Higher Education Institution. *Mediterranean Journal of Social Sciences*, 5, 4, 69-77.

Barkhuizen, E.N., Schutte, N.E. & Smit, A. (2015). Talent Management, Motivation and Service Quality of Support staff in a public higher education institution. *Journal of Public Administration*, 50, 1, 658-673.

Barkhuizen, E.N., & Stanz, K.J. (2010). *Linking organisational energy and individual well-being: The Influence of Leader's Talent Mindset*. Paper published in the peer reviewed conference proceedings of the 12th Annual Conference of Global Business and Technology Association, Kruger National Park, South Africa, 5-9 July, pp. 50- 57, Gbata, USA, ISBN: 1-932917-06-3

Blass, E. (2007). *Talent Management: Maximising talent for business performance*. Chartered Management Institute and Ashridge Consulting Limited.

Born, M. & Heers, M. (2009). Talent Management: Alternatives to the single ladder approach. *Dansk Erhvervs Akademi*.

Creelman, D. (2004). *Return on investment in talent management: Measures you can put to work right now*. Human Capital Institute, Washington.

Davies, B. & Davies, B. (2010). Talent Management in Academies. *International Journal of Educational Management*, 24, 418-426.

- Field, A. (2009). *Discovering statistics using SPSS*. (2nd ed.). London: Sage Publications.
- Garrow, V. & Hirsch, W. (2008). Talent Management: Issues of focus and fit. *Public Personnel Management*, 37 (4), 389-402.
- Lawler, E.E. (2008). *Talent, making people your competitive advantage*. San Francisco: Jossey-Bass.
- Lesenyeho, D., Barkhuizen, E.N., & Schutte, N.E. (2017). *Exploring the causal relationships between the antecedents and consequences of early career academics in South African Higher Education Institutions*. Unpublished research paper.
- Magolego, H., Barkhuizen, E.N. & Lesenyeho, D.L. (2013). Talent Management and Job Performance: The Mediating Role of Job Satisfaction. In S.M. Lee & G. Roodt (Eds.), *30th Pan Pacific Conference, Johannesburg, South Africa* (pp. 132-135), ISBN: 1-931649-27-3. PPBA
- Molefi, M.A. (2015). A structured model of talent management for professional nurses in the North-West Province. Unpublished Doctoral Dissertation, Department of Industrial Psychology, North-West University, Mmabatho, South Africa.
- Roodt, E., Barkhuizen, E.N. & Lesenyeho, D.L. (2013). Job Demands and Job Resources as Predictors of Dispositional Employability of Academic Staff. In S.M. Lee & G. Roodt (Eds.), *30th Pan Pacific Conference, Johannesburg, South Africa* (pp. 270-272) ISBN: 1-931649-27-3. PPBA.
- Saurombe, M.D. *Talent Management as a predictor of positive work related outcomes for academic staff in South African Higher Education Institutions*. Unpublished Masters Dissertation, Department of Industrial Psychology, North-West University, Mmabatho, South Africa.
- Saunders, M., Lewis, P. & Thornhill, A. (2009). *Research Methods for Business Students (5th ed)*. England: Pearson Education Limited.
- Saurombe, M., Barkhuizen, E.N., & Schutte, N.E. (2017). Management perceptions of a higher educational brand for the attraction of talented academic staff. *SA Journal of Human Resource Management/SA Tydskrif vir Menslikehulpbronbestuur*, 15(0), a831. <https://doi.org/10.4102/sajhrm.v15i0.831>
- SPSS Inc. (2016). *SPSS 23 for Windows*. Chicago, IL: Author.
- Theron, M., Barkhuizen, E.N., & Du Plessis, Y. (2014). Managing the academic talent void: Investigating factors in academic turnover and retention in South Africa. *South African Journal of Industrial Psychology*, 40, 1, 1-14.
- Woodruffe, C. (2003). To have and to hold: Getting your organization onto talented people CVs. *Training Journal*, 20-24.
- Yarnall, J. (2007). *Strategic career management – Developing your talent*. Oxford: Butterworth-Heinemann

COMMUNICATION FOR TOURISM DEVELOPMENT IN COMMUNITIES: A CASE STUDY IN PUNA ISLAND

Alba Caicedo Barreth and Alba Barreth González
University of Guayaquil, Ecuador

Alex Franco Rodríguez
Escuela Superior Politécnica del Litoral, Ecuador

ABSTRACT

This study pretends to review communication and tourism development as two specific theories in a case study, from the question: How does communication intervene in community tourism development? The main aim of the research refers to analyze the communication process from inside to outside of a community that is working towards tourism development. This qualitative research was applied through analysis of 4 tourism groups over the use of propositions as guide of the research process (Yin, 2003). Results refers to the description of elements in Puná Island concerning interrelation of community, information, ways of communication and tourists. Practical applications include evidence and relevance of considering intersubjective communication in tourism development studies.

Keywords: communication, tourism, development, community, Puná Island.

INTRODUCTION

Adequate community communication leads to effective collaborative efforts in issue of development (Olufunke, Wuraola & Oluwafunmilola, 2010). Over that premise this paper tries to review a case study in Puná Island, one of the biggest but not well developed island of Ecuador.

Puna has an extension of approximately 919 km², located in the Gulf of Guayaquil and to 61 km from Guayaquil, the economical capital of Ecuador. Traditional activities in this Island include fishing, agriculture and mollusks catching, however in the last years, working in tourism field has been carried out by some people. So, first demonstration in tourism development has been afforded by the communes: Subida Alta, Cauchiche, Estero de Boca and Bellavista, who also have received government attention in tourism area.

In consequence, in this paper, these four communities will be principally reviewed as particular parties and eventually considered as a single space to understand the current condition of tourism development in that area, set from communication.

THEORETICAL REVIEW

Communication

Community communication is a key element for changes, progress, and collective alteration (Sarvaes and Liu 2007). FAO (2006) also refers that communication allows development, and it is used for people's participation, decision making, confidence building for raising awareness, sharing knowledge and changing attitudes, behavior or lifestyles. The same organization states that communication for development refers to a planned and systematic path through inter-personal channels, ICTs, audio-visuals and mass media. This kind of communication focuses on two areas: information dissemination and motivation training of field workers and rural members. Those aspects mean the relevance of communication for rural development is having countless challenges.

The main dares facing rural progress through communication involves shared responsible. The first challenge is dearth of information, meaning that unknown things could block up growth. Conflicting messages are another problem, in the way that sometimes the information to be diffused is not the correct or relevant. Finally, ICT is the last dare to face, where lack of infrastructure or low levels of skills converge. Accordingly, FAO (2006) also states a framework of six components for efficient communication: policies, capacities, monitoring and evaluation, farmer's organization, participatory methods, media strategy.

Nowadays a physical area is not a requirement to get communicated, because of technology, which has facilitated connection among people (Ninova, 2008, p. 303). Thus, social networks allow personal relations and encourage new ways of collective organizations (Valiente, 2008, p. 1). This digital communities are new models of communicate action, empowering communities, social and institutional relationships (Ferri, 1999, p. 79, quoted in Valiente, 2008, p. 3).

As every interpersonal relationship implies a way of communication, human beings when have interaction with others are communicating, because their essence is to be in touch with others, and interpersonal communication is produced in that corporeity (Sodhi, 2008, p. 31). In other context arise intersubjective communication, which is based in consensuses and agreements, and those are the differential element from interpersonal communication. Rizzo (2014) said that the intersubjective communication could have three theoretical bases: Symbolic interactionism, phenomenological sociology and the Theory of Communicative Action.

Symbolic interactionism refers to the analysis of interactions of society, Herbert Blumer, George Herbert Mead, Charles Horton Cooley and Erving Goffman, were the main exponents of that theory. Blumer (1968) synthetized this approach in three basic premises: a) people act according meaning of objects and situations, b) the meaning of things are outcome of social interaction among individuals, c) the interpretation process is done by relationship of individuals and things. Meanwhile Cooley (1909) mentions the meaning of "I mirror", where human being is the product of interaction with others. In summary, intersubjective communication is the base for symbolic interactionism.

Accordingly, Habermas (1987) considers the interdependency of culture, society and personality in the world in terms of intersubjective communication. Hernández & Galindo (2007) refers the term mean people and interrelations which are in the current world. Considering above descriptions, intersubjective communication institutes social reality, giving importance to objects, speakers' relations and building of human being, named by Vizer (2003) as referential, inter referential, and auto referential dimension. (Vizer, 1982, quoted in Vizer, 2003, p. 191)

Myers & Myers (1982) state communication as the central power to coordinate people and organize behavior. Trelles (2001) also refers that communication manage behavior and stablish interpersonal relations to get a goal. In summary, intersubjective communication is the base for symbolic interactionism (See figure 1). In those basis a proposal could arise for this study: Communities from Puná have lack of intersubjective communication.

Figure 1: Process of symbolic interactionism

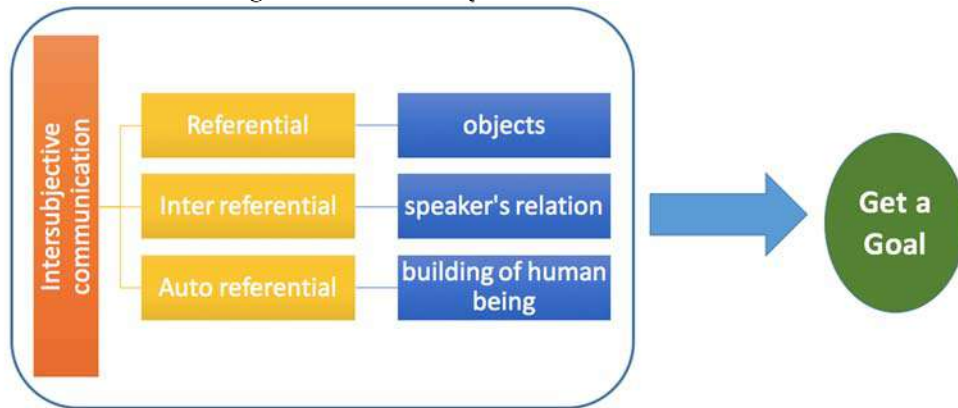

Source: Based on Habermas (1987), Hernández & Galindo (2007), Trelles (2001) and Vizer (2003)

Community

Etymologically community comes from the latin communis, cum (jointly) and munus (load, due), thus the term refers a relationship with mutual obligations. George Hillery (1955) found out the meaning of community, after analyzing 94 definitions of the term in qualitative and quantitative mode, concluding that the term denotes people. Others refer to share and be together, and in that meaning community approaches to communication (Rizzo, 2013).

Benedict Anderson (1993) indicates that community could be a social organization when members recognize be part of a group and act in function of a representation. In addition, Siles (2005) refers that nowadays community is supported by informatics networks, diversifying the ways of meeting people. He also suggests that a virtual community would be a world of exchanges, able to reorganize social ties and to stimulate democratic life. Ninova (2008) agrees with that concept, noting that community gets banished and individualized, and it becomes a network although is geographically dispersed.

In consequence, In Puná Island's studies are necessary to include in terms of community the population and people who had been communicated with (See figure 2).

Figure 2: Components of community

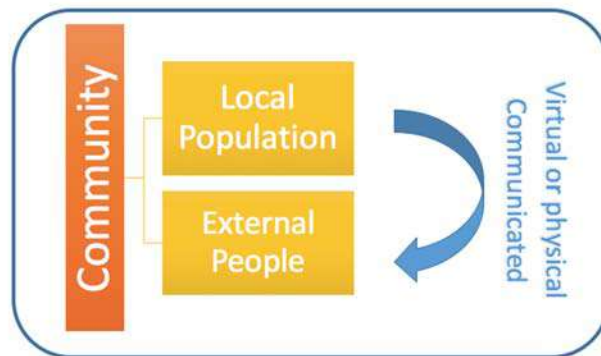

Based on Rizzo (2013) Ninova (2008) and Siles (2005)

Tourism development

For UNWTO tourism development goes together with sustainability, so meaning includes environmental, economic and socio-cultural aspects, which must be balanced and procure long-term existence. The optimal use of environmental resource is one of the main element for tourism development, where conserve biodiversity is essential. As second fact,

host communities must respect their socio-cultural heritage, and tourism must contribute to that inter-cultural understanding between tourists and communities. Finally, tourism development provides socio-economic benefits to all stakeholders, including stable employment and social service to host communities, ensuring long-term economic operations.

In addition to the above mentioned aspects, sustainable tourism development requires “strong political leadership to ensure wide participation and consensus building (...) constant monitoring of impacts, introducing the necessary preventive and/or corrective measures whenever necessary” (UNWTO, 2005). Some studies refer linkage of state and market as support for development, Barry (1999) and Sachs (1998) declares development in economic terms. Meanwhile O’Hearn adds political features and state’s potential to promote development, nevertheless the state as main piece to reach development are supporting by Adeshead et al. (2008); Boyle (2005); Kirby (2002, 2010); O’Connell & Ó Riain (2000); O’Donnell (1999, 2008); O’Malley (1989, 1992, 1998); Ó Riain (2004, 2008, 2010) and Smith (2005) cited by Wang et al (2013).

A positive outcome for which tourism development is supported in rural regions is because of poverty alleviation, besides some authors as Gu and Zhang (2009), Davis and Morais (2004), Hassan (2000), McGehee and Andereck (2004) mention nowadays tourism forces to sustainable environmental protection. In summary tourism development could maintain traditional culture, poverty eradication, increasing income and active economy (Bachleitner and Zins 1999; Tosun 2000; Yao et al. 2007).

How to measure tourism development has been an important challenge to achieve. Since 1993 guidelines on statistics for tourism were introduced by WTO, they included tourism demand, tourism supply and tourism expenditure. In tourism demand was considered the level of visitation to the destination (characteristics of tourists, size of market, visitor assessment). About the supply, the tourism infrastructure in terms of facilities, attractions, economic contribution, socio-environmental impact. Finally, tourism expenditure comprises to measure wealth transferred to destination, contribution to economy and linkage with other sectors (Silva, 2000)

Dupeyras and MacCallum (2013) note 11 quantitative indicators to measure competitiveness in tourism: tourism direct gross domestic product, inbound tourism revenues per visitor by source market, overnights in all types of accommodation , exports of tourism services, labor productivity in tourism services, purchasing power parities (ppps) and tourism prices, country entry visa requirements, natural resources and biodiversity, cultural and creative resources, visitor satisfaction, national tourism action plan. They also mention 5 supplementary indicators: Market diversification and growth markets, employment in tourism by age, education levels and type of contracts, consumer price index for tourism, air connectivity and inter-modality, OECD better life Index. Finally, those authors define as future development indicators:

- government budget appropriations for tourism
- company mortality rate
- use of e-tourism and other innovative service
- structure of tourism supply chains

Nevertheless, UNWTO since 2015 is trying to define a framework to measure sustainable tourism, in this point some policy implications are over the table: Economic viability, local prosperity, employment quality, social equity, visitor fulfillment, local control, community wellbeing, cultural richness, physical integrity, biological diversity, resource efficiency and environmental purity (UNSD, 2016) in consequence united nations statistics division concludes that statistical framework contains:

- tourism statistics
- environment statistics
- national accounts, employment, trade and other economic statistics
- environmental-economic accounting
- tourism satellite accounts
- transport and mobility data,
- geo-spatial and regional statistics data
- classifications of activities, products and environmental stocks and flows

Consequently, some of the above noted elements will be used in this qualitative study, thus a final question emerges in this study: What linkage could have communication with development in a community.

METHODOLOGY

This research applied a methodology concerning the analysis of a case study, as an appropriate means to explore individuals, through complex relationships, communities, or programs (Yin, 2003). In that basis, over the geographical line, boundaries of the case refer to review 4 of the community-based tourism of Puná Island: Subida Alta, Cauchiche, Estero de Boca and Bellavista, which have been working in tourism in the last 10 years. The collect data process was done in 2016 and the analysis of those information completed in 2017. (Creswell, 2003)

According to Yin's case study categories, this document pretends to be a descriptive analysis, where propositions will be helpful to develop the research process, grounded in a conceptual framework, for analyzing through pattern matching, linking data, explanation and synthesis (Baxter & Jack, 2008). This study contemplates an embedded design as unit of analysis (Yin, 2003), and as source of evidence was considered documents, interviews and direct observations.

RESULTS

Results will be presented according to proposal exposed, over the basis of theoretical review of part III. Analyzing communication in communities of Puná from Rizzo's view, could be referred in three points: a) main economic activity of people in Puná is fishing, however tourism is also well positioned in Bellavista and Subida Alta; in the first commune because it is the port of entrance of visitors, and in the second one because a viewpoint was built, which facilitates the stay of tourists. b) People feel descendants from Punaes tribes, and as result, they refer to have courage and straighten in their daily acts. c) Every analyzed group demonstrated different interpretation of the things and also relationship among population.

Communes in Puná use face to face communication, a leader is chosen every year and a committee is fitted. Committee tries to organize population, to represent in front authorities and to manage programs and activities in the area. In Bellavista, community authorities have not a good relationship with population, as well as in the community of Subida Alta, so lack of interpersonal relations could be fast perceived. Estero de Boca shows a good sense of relations between leader and population, people could be quickly met for interviews and almost everyone refereed the same speech. Cauchiche's leaders exposed availability of interaction with interviewers but in contrast given information does not match with reality and capacity to convene people was almost null.

Due to communication refers interaction with others, give and receive messages through signs, symbols, clues, meanings, experiences and feelings; the ways that population gets in contact with potential tourists was reviewed in Puná. There are 2 State websites and 3 particular ones, where information about Puná is declared. From Municipality of Guayaquil, www.guayaquilesmidestino.com describes the 4 communes and general information of Puná in 982 words and 5 photos, it has also a link access to google map, social networks and comments where the last note was written 2 years ago; 2 telephone numbers and an e-mail are also shown. From Guayas Government, www.guayas.gob.ec describes a day trip in Puná 5 years ago, and 32 photos are attached. The particular website Visitaecuador.com presents in 144 words geographic characteristics of Puná, but no photos are exposed. Ecostravel.com displays information about tour packages, costs, itineraries and many photos about flora and fauna of that area. Ecured.cu details in 1291 words origin, history, tourist attractions, general characteristics and festivals in Puná, 7 photos are also attached. Furthermore, operators have created some fan pages in social networks, there were about 5 on Facebook, 5 on Instagram and 5 on Twitter, who try to describe offered service through message and photos, the publication arise almost every month, however few answers could be seen from tourists or potential visitants showing interaction. In conclusion updated information about Isla Puná is not found on internet, or only appear in social networks, internet as a system of communication with tourists has been neglected.

In terms of development, as was mentioned earlier, is relevant state and market. Government has been immersed in the last ten years in Puná. Ministry of Tourism and Municipality of Guayaquil have been in charge of various tourism projects in those areas (EPMT, 2015). In 2010, structures as bridges for the communities Bellavista and Cauchiche were built by the central government; consequently, studies for an eco-lodge and a pier for those areas were also conducted. At the same time, the Municipality of Guayaquil trained the population and included them in the promoting of a few tourism routes. Besides, the Ministry of Tourism and the Ministry of Environment have continued with the improvement of a number of tourism infrastructures; for instance, the viewpoint, the ecolodge and the pier. Nevertheless, the main problem is not working together, communication among those institution is almost null.

About market, visitants are almost null in Estero de Boca and Cauchiche, tourism infrastructures as Ecocamping lack of maintenance as consequence of no visitors. The most visited area in Puná Island is Bellavista, because it is the main entrance to community, has a long beach with restauration services and people try to work together; on weekends about a hundred of visitants could be found there. Subida Alta has reached relevant tourism infrastructures but visitors disregard the existence of those areas, people go there only by specific groups and not by own motivation. Travel agencies and tour operators do not consider Puná Island in their package as destination, sometimes they offer tours around those areas but no lodging or having a meal inside. Internal servers have not complete connection with tourists, they are maybe well known by nearby regions who go as excursionists (less than 24 hours) but not for real tourists.

In consequence the positive development of those destinations is not entirely visible, problems in communication have induced to negative outcomes: poorly used infrastructures such as the viewpoint in Subida Alta, low credibility towards tourism sector by population in Estero de Boca, lack of interest in training programs, low influx of tourists, abandonment of tourism projects as eco camping in Cauchiche, etc. Here, theory from Cooley (1909) is certainly appropriate to mentions: “I mirror” is present in Puná Island, but in a negative way.

CONCLUSION

Communication is the main component of daily life, and not only comprise spoken speech, it also refers digital, written and visual messages. Intersubjective communication states every way of interaction among participants of the whole group: host community and tourists. Puná Island serves as reference to demonstrate that lack of communication generates deficient outcomes in development. Although it has not been done statistical measurement, observation, interview and documental review were enough to assess information about state, market, services, host community and tourists.

Tourism development in a destination requires a complex number of indicators, nevertheless intersubjective communication is immersing in the total process because if every component of system executes an individual work, a common or global welfare will not be achieved. Hence, as managerial implications of this study to consider as main element intersubjective communication in a tourism development plan is suggested; appropriate budget, attractions, e-tourism and innovate service from community and government could support management of foreign tourists, schemes applied in several successful tourism destinations.

Analysis of communities using quantitative data is recommended to further studies, considering that this research was limited to a case study review.

REFERENCES

- Anderson, B. (1993). *Comunidades imaginadas. Reflexiones sobre el origen y la difusión del nacionalismo*, México: Fondo de Cultura Económica.
- Baxter, P., & Jack, S. (2008). Qualitative case study methodology: Study design and implementation for novice researchers. *The Qualitative Report*, 13(4), 544-559. Retrieved from <http://www.nova.edu/ssss/QR/QR13-4/baxter.pdf>
- Cooley, C (2005) *El yo espejo. CIC (Cuadernos de Información y Comunicación)*
- Creswell, J. (1998). *Research design: Qualitative, quantitative, and mixed methods approaches* (2nd ed.). Thousand Oaks, CA: Sage.
- Dupeyras, A. and MacCallum, N. (2013) Indicators for Measuring Competitiveness in Tourism: A Guidance Document. *OECD Tourism Papers, 2013/02, OECD Publishing. Retrieved from: <http://dx.doi.org/10.1787/5k47t9q2t923-en>*
- FAO (2006) Communication a key to human development. *Natural Resources Management and Environment Department*. Retrieved from: <http://www.fao.org/docrep/t1815e/t1815e01.htm>
- Habermas, J (1989) *Teoría de la Acción Comunicativa*. Taurus, Buenos Aires.
- Hernández, Y & Galindo, R (2007) El concepto de intersubjetividad en Alfred Schutz. *Espacios públicos*, 10 (20), p. 228-240
- Myers, M. & Myers, G (1993) *Administración mediante la comunicación. Un 119 enfoque organizacional*. México: Ed, McGraw-Hill.
- Ninova, M. (2008). Comunidades, software social e individualism conectado. *Athenea Digital*, núm. 13, pp. 299-305. Retrieved from <http://psicologiasocial.uab.es/athenea/index.php/atheneaDigital/article/view/460/400>
- Olufunke, M., Wuraola, C & Oluwafunmilola, E. *The Impact of Communication on Community Development*. J Communication, 1(2): 101-105 (2010). Retrieved from: <http://www.krepublishers.com/02-Journals/JC/JC-01-0-000-10-Web/JC-01-2-000-10-Abst-PDF/JC-01-2-101-10-012-Adedokun-M-O/JC-01-2-101-10-012-Adedokun-M-O-Tt.pdf>
- Rizo, M (2013) Digital interpersonal communication and new community forms. Reflections on pos-massive communication. *Imagonautas* 3 (2), México.
- Rizo, M. (2014). Comunicación interpersonal y comunicación intersubjetiva. Algunas claves teóricas y conceptuales para su comprensión. *Anuario Electrónico de Estudios en Comunicación Social "Disertaciones"*, 7(2), Art 1. Retrieved from: <http://revistas.saber.ula.ve/index.php/Disertaciones/>
- Rizo, M (2014). From the Interpersonal to the Intersubjective. Some Theoretical and Conceptual Clues for Defining Intersubjective Communication. *QUORUM Academico. Vol 12 (2). Pp 290 – 307*
- Sarvaes, J & Liu, S (Eds.) 2007. *New Approaches in Communication and Community Development. Moving Targets: Mapping the Paths Between Communication, Technology and Social Change in Communities*. Penang, Malaysia: Southbound.
- Siles, I. (2005). Internet, virtualidad y comunidad. *Revista Ciencias Sociales*, núm. 108, pp.55-69. Retrieved from: <http://www.vinv.ucr.ac.cr/latindex/rcs002/04-SILES.pdf>

Silva, M (2000). *Sustainable Tourism Development in the Caribbean: Identifying Measurement Instruments*. Workshop on environmental statistics for CARICOM member countries. CARICOM, United Nations Statistic Division. Belize

Trelles, I. (2001): Comunicación Organizacional. *Selección de Lecturas*, La Habana, Ed. Félix Varela.

UNWTO (2005) Making Tourism More Sustainable - *A Guide for Policy Makers*, UNEP and UNWTO, p.11-12

UNSD (2016) Measuring Sustainable Tourism: Developing a statistical framework for sustainable tourism. *Memories of 11th meeting of UNCEEA*. Retrieved from: https://unstats.un.org/unsd/envaccounting/ceea/meetings/eleventh_meeting/SM-11-2-a.pdf

Valiente, F (2008). “Redes sociales y nuevos espacios de socialización”. Retrieved from: <http://www.csviator.es/2009-11-21%20Redes%20sociales%20y%20nuevos%20espacios%20de%20socializaci%C3%B3n.pdf>

Wang, L, Cheng, S., Zhong, L, Mu, S., Dhruba, B., Ren, G (2013). Rural Tourism Development in China: Principles, Models and the Future. *Journal of Mountain Science*. Vol 10, pp 116–129. doi: 10.1007/s11629-013-2501-3

Yin, R. K. (2003). *Case study research: Design and methods* (3rd ed.). Thousand Oaks, CA: Sage.

COSMOPOLITANISM VERSUS ETHNIC IDENTITY AMONGST SOUTH AFRICAN GENERATION Y STUDENTS

Ayesha L. Bevan-Dye
North-West University (Vaal Triangle Campus), South Africa

ABSTRACT

Traditionally, cosmopolitanism and ethnicity were viewed as bipolar opposites, with a strong tendency towards the one precluding a strong tendency towards the other. However, studies are now reporting that individuals often exhibit a strong sense of ethnicity while simultaneously being cosmopolitan. This paper reports on a study undertaken to determine South African Generation Y university students' tendencies towards ethnic identity and cosmopolitanism. Questionnaires were distributed to a convenience sample of 399 university students in South Africa. Data analysis included confirmatory factor analysis, descriptive statistics, MANOVA, z-tests and correlation analysis. The results indicate that South African Generation Y students have a glocal cultural identity in that they exhibit a strong ethnic identity as well as a strong cosmopolitan tendency and that the one relates to rather than negates the other.

Keywords: Cosmopolitanism, ethnic identity, South Africa, Generation Y university students.

INTRODUCTION

In the early 1980s, Levitt (1983, p.92, 93) predicted that technology-driven globalisation would render national and regional differences in consumer behaviour obsolete, in both developed and less developed countries. His reasoning was that exposure through the media and travel to modern possibilities, whether it be entertainment, productivity, fashion, financial, technological or even food related, has created a thirst for global brands and a worldwide shift towards cosmopolitanism. Stepping forward 34 years to 2017 adds credence to these words. The Internet, global news, sport and entertainment media channels, and global social networking sites have spurred the wide-spread adoption of Western consumerism and given rise to the emergence of a global generational consciousness – something that started in the 1960s with the coming of age of the Baby Boomers but which is particularly true of today's youth (Strizhakova, Coulter & Price, 2012, p.44; Edmunds & Turner, 2005, p.571), labelled the Millennials or Generation Y.

Born between 1986 and 2005 (Markert, 2004, p.21), Millennials are history's first digitally-connected generation (Taylor & Keeter, 2010, p.1) and are comfortable with technology, technologically astute and use tools such as the Internet, smartphones and social media as a natural and integral part of their lives (Barton, Fromm & Egan, 2012, p.4). Global television news channels that report 24/7, such as CNN and Sky News, have allowed Generation Y individuals to witness wars, natural disasters and other newsworthy events live as they occur around the world. Global media have assailed them with reports on the threats of terrorist attacks, economic and social meltdowns, environmental catastrophes (Shaw & Fairhurst, 2008, p.373) and the dangers of a range of consumption behaviours, including the consumption of alcohol, tobacco and various types of food (King, 2009, p.89). In today's connected world of convergent technologies, multi-media platforms and global television networks, many popular films and television series, typically generated in Westernised countries, gain a global following simultaneously, and celebrities, music and vogues that gain in popularity in one part of the world quickly trend across the globe. In combination, these factors have contributed to the Millennials manifesting as a true globalised phenomenon.

Does this then mean that Levitt's (1983, p.96) prediction that cultural preferences and, by implication, ethnic identity are "vestiges of the past" or is it possible to retain one's ethnic identity while simultaneously embracing cosmopolitanism?

LITERATURE REVIEW

In international marketing literature, the global versus local approach debate has a long history (Mareck, 2014, p.26; Douglas & Wind, 1987, p.20). Based on the notion that technology-driven globalisation has led to the homogenisation of world preferences, Levitt (1983, p.93, 94) advocates the global standardisation of products and marketing efforts across industries in order to reap the benefits of economies of scale and scope, and compete on the basis of value. This involves adopting a global, rather than country-by-country or region-by-region perspective to marketing strategy formulation and implementation (Svensson, 2002, p.575). While Kotler (1986, p.13) concedes that, under certain circumstances, it may be possible to offer a globally standardised marketing offering, he advocates following the local approach whereby marketing elements, whether they be product features, labelling, packaging, colours, brand name, advertising appeals, media channels or price, be adapted to fit with the needs of different countries or regions. In international market segmentation, this essentially means treating each country or region as a separate and distinctive market, and developing a different marketing mix in line with the preferences of each of those markets (Cleveland, Papadopoulos & Laroche, 2011, p.246). A third option on this global-local continuum is the glocal approach, which involves blending a global appeal with a local appeal (Kipinis, Broderick & Demangeot, 2014, p.235; Robertson, 2012, p.195). This hybrid approach involves standardising certain elements of the marketing mix, while adapting other elements to local market conditions (Douglas & Wind, 1987, p.27). Despite advocating a local approach to international marketing efforts, in a sense, this was what Kotler (1986, p.14) was suggesting. Which approach is best depends on the ethnicity-cosmopolitan distinction in a market (Robertson, 2012, p.195), which may be global, local or glocal (Ger & Belk, 1996, p.288), with a glocal cultural identity defined as "as the coexistence of a broad range of beliefs and behaviours embedded to varying degrees in both local and global discourses" (Strizhakova *et al.*, 2012, p.43).

Ethnic identity is more than mere ethnic origin in that it refers to "the incorporation of ethnicity into the individual's self-concept" (Cleveland *et al.*, 2011, p.246). It is a form of self-identification that implies pride in and adherence to certain cultural values, traditions, religion and language usage (Webster, 1994, p.321). Ethnic identity is a cultural phenomenon in that it is based on the idea that people belong to and identify with particular cultural groups (Cleveland & Laroche, 2007, p.250).

South Africa is an especially interesting country for researching the concept of ethnic identity in that while there is a strong national ethnic identity of being South African, there is also cultural heterogeneity, as is evident from the country's 11 official languages. It is a country that provides constitutional recognition of all cultural traditions and actively encourages heritage maintenance, while simultaneously promoting an all-inclusive strong national identity (Adam, 1995, p.459, 460). Kipinis *et al.* (2014, p.233) argue that in a multi-cultural marketplace, such as South Africa, consumers' identities, through a process of acculturation, evolve to incorporate the multiple cultures to which they are exposed in their daily lives. As such, the South African ethnic identity may be viewed as a national one that encompasses its cultural diversity.

Individuals with a strong ethnic identity or cultural pride are more likely to align their consumption behaviour to their cultural traditions, which may include the consumption of ethnic foods and the purchase of ethnic products, including clothing, art, music, literature, entertainment and media (Schiffman, Kanuk & Wisenblit, 2010, p.393). In addition, ethnic identity may influence responses to cultural cues used in advertising messages, perceptions of culture-of-brand-origin, perceptions of a brand's image (Kipinis *et al.*, 2014, p.233, 234) and, ultimately, the acceptance of and purchase intentions towards a brand (Schiffman *et al.*, 2010, p.366). Moreover, a strong ethnic identity may translate into consumer ethnocentrism, which is a preference for local over foreign brands. One study found that Generation Y students in South Africa exhibit a statistically significant consumer ethnocentric tendency (Bevan-Dye, Garnett & De Klerk, 2012, p.5583).

In contrast to ethnic identity, cosmopolitanism refers to an affinity for cultural diversity (Riefler & Diamantopoulos, 2009, p.408). A cosmopolitan individual is oriented towards the global society rather than being restricted by the boundaries of his/her local community; that is, the individual has an ecumenical as opposed to parochial view of the world (Merton, 1968, p.447). Cosmopolitanism is the conscious attraction to “products, experiences and places from other cultures” (Schiffman *et al.*, 2010, p.155). This curiosity about and attraction to different cultures may manifest as the “consumption of global brands, icons, peoples, heroes, public figures, foreign travel and multi-cultural food” and/or as an awareness of global issues (Matthews & Sidhu, 2005, p.53). At a superficial level, cosmopolitanism appears to negate ethnic identity. However, Beck and Sznaider (2006, p.20) observe that cosmopolitanism presupposes ethnic identity in that a curiosity and openness to other cultures necessitates a recognition of ethnicity and cultural diversity. The findings of an eight country study that included Greece, Hungary, Sweden, Mexico, Chile, Canada, South Korea, and India support that observation, concluding that there is a positive relationship between cosmopolitanism and ethnic identity, which suggests that increasing levels of cosmopolitanism do not imply an erosion of ethnic identity or vice versa (Cleveland *et al.*, 2011, p.253).

The purpose of the study reported in this paper was to determine South African Generation Y university students’ tendencies towards ethnic identity and cosmopolitanism. In addition, the study sought to determine whether there are any cultural or gender differences concerning ethnic identity and cosmopolitanism, and whether there is any congruency between these two tendencies.

RESEARCH METHODOLOGY

Participants

This study followed the descriptive research design and utilised the single cross-sectional approach to gather the required data. In the study, the target population was defined as university students registered at public South African higher education institution (HEI), aged between 18 and 24 years. For the sampling frame, judgement sampling was used to select four campuses from three HEIs - one from a comprehensive university, two from a traditional university and one from a university of technology. Following the mall-intercept survey method, 440 questionnaires were distributed by fieldworkers to a convenience sample of students at the four campuses who agreed to take part in the study. Of the 440 questionnaires handed out, 427 were returned. Of the 427 returned, 17 were discarded because they indicated being older than 24 years, and 11 because they had missing values of 10 percent and/or had failed to indicate their age. As such, the final sample size was 399 participants, yielding a response rate of 91 percent. There were more female than male participants in the sample. In terms of representativeness, the sample comprised participants from each of South Africa’s nine provinces and 11 official language groups, and participants from each of the seven age categories specified in the target population. A description of the sample participants is provided in Table 1.

Table 1: Sample description

Age	Percent (%)	Gender	Percent (%)	Province	Percent (%)	Language	Percent (%)
18	11.8	Male	42.6	Eastern Cape	3.6	Afrikaans	11.5
19	31.1	Female	57.4	Free State	10.7	English	4.3
20	20.3			Gauteng	50.1	Ndebele	2.0
21	15.5			Kwazulu-Natal	4.1	Xhosa	8.7
22	13.5			Limpopo	15.8	Zulu	12.8
23	4.5			Mpumalanga	4.8	Northern Sotho	11.2
24	3.3			North West	9.9	Southern Sotho	25.0
				Northern Cape	0.3	Tswana	11.2
				Western Cape	0.8	Swati	3.6
						Venda	5.1
						Tsonga	4.6

Research instrument

A self-administered questionnaire was constructed to gather the required data. This questionnaire included two single-construct measurement scales from published studies. Ethnic identity was measured using the 11-item identification with and desire to maintain ethnic culture scale (Cleveland *et al.*, 2011, p.265) and cosmopolitanism was measured using the seven-item cosmopolitanism scale (Cleveland *et al.*, 2011, p.265; Cleveland & Laroche, 2007, p. 254). These scaled-response items were measured on a six-point Likert scale ranging from (1) strongly disagree to (6) strongly agree. In addition, the questionnaire had a section requesting the demographic information presented in Table 1.

Prior to distribution, the questionnaire was submitted to the Ethics Committee of the Faculty of Economic Sciences, North-West University (Vaal Triangle Campus) for ethical clearance. Ethical clearance was subsequently granted (Ethical Clearance Number: ECONIT-2015-011). In addition, all responses were reported in aggregate and student participation was voluntary.

Data analysis

The captured data was analysed using the IBM Statistical Package for Social Sciences (SPSS) and Analysis of Moment Structures (AMOS), Versions 24 for Windows. Data analysis procedures used included confirmatory factor analysis, together with reliability and validity analysis, descriptive statistics, a one-sample z-test, a multivariate analysis of variance (MANOVA), a two-independent sample z-test and Pearson's Product-Moment correlation analysis.

The structural equation modelling approach to confirmatory factor analysis was utilised because of the value it offers in assessing construct validity (Brown & Moore, 2012, p.362). The specified measurement model was assessed for potential estimate concerns such as negative error variances and standardised loading estimates below -1.0 or above 1.0 (Kline, 2011, p.158). The reliability and construct validity of the model were evaluated by assessing the composite reliability (CR), the correlation coefficient, the average variance extracted (AVE), the square root of the AVE values and the Cronbach's alpha. Acceptable CR and internal-consistency reliability are indicated by respective CR and Cronbach alpha values above 0.7. Standardised loading estimates above 0.50, together with AVE values of 0.50 or above suggest convergent validity and squared root AVE values that exceed the correlation estimates suggest discriminant validity (Hair, Black, Babin & Anderson, 2011, p.125, 709,710). The measurement model fit was assessed using the most "widely accepted global goodness-of-fit indices", namely the chi-square, the standardised mean square residual (SMSR), the root mean square error of approximation (RMSEA), the Tucker-Lewis index (TLI) and the comparative fit index (CFI) (Brown & Moore, 2012, p.369), where SMSR and RMSEA values of 0.08 or below, together with TLI and CFI values of 0.90 or above, and a non-significant chi-square value are indicative of a good fit (Malhotra, 2010, p. 732, 733). Brown and Moore (2012, p.369) note that while the chi-square value is typically reported, its high sensitivity to sample size negates the possibility of achieving a non-significant value in applied research.

The level of statistical significance was set at $p < 0.05$ for the one-sample z-test, the MANOVA, the two-independent samples z-test and the correlation analysis.

Results

A two-factor measurement model was specified for confirmatory factor analysis that comprised the cosmopolitanism latent factor (seven observed variables) and the ethnic identity latent factor (11 observed variables). For model identification purposes, the first loading on both the latent factors was fixed at 1.0. This resulted in 171 distinct sample moments and 37 parameters to be estimated, which resulted in 134 degrees of freedom (df) based on an over-identified model and a chi-square value of 484.987, with a probability level equal to 0.000. The 11:1 ratio between number of participants to number of parameters to be estimated renders the sample size of 399 sufficient for conducting structural equation modelling (Whittaker, 2016, p. 720).

Table 2: Estimates for measurement model

Latent factors	Standardised loading estimates	Error variance estimates	CR	AVE	$\sqrt{\text{AVE}}$	Cronbach alpha
Cosmopolitanism	0.723	0.522	0.87	0.50	0.71	0.894
	0.828	0.686				
	0.675	0.456				
	0.830	0.688				
	0.767	0.589				
	0.667	0.445				
	0.704	0.496				
Ethnic identity	0.664	0.440	0.92	0.50	0.71	0.925
	0.718	0.516				
	0.805	0.648				
	0.836	0.698				
	0.747	0.558				
	0.769	0.591				
	0.737	0.542				
	0.657	0.432				
	0.724	0.525				
	0.682	0.465				
0.689	0.474					
Correlations	F1↔F2: 0.411					

The results shown in Table 2 indicate that there are no problematic estimates in the measurement model and that the association between each indicator and their respective latent factor is statistically significant ($p < 0.01$). CR values and Cronbach alpha values above 0.70 suggest respective composite and internal-consistency reliability. There are also indications of convergent validity, with the standardised loading estimates above 0.50 and AVE values equal to 0.50, together with discriminant validity, given that the square root of the AVE of both latent factors exceeds the correlation coefficient. In terms of the model fit, despite a significant chi-square value the other fit indices returned values indicative of acceptable model fit, with a SRMR of 0.046, a RMSEA of 0.081, a TLI of 0.903 and a CFI of 0.915.

The descriptive statistics were then calculated, together with a one-sample z-test, where the expected mean was set at 3.5. The results are presented in Table 3.

Table 3: Descriptive statistics, Z-values and p-values

Constructs	Means	Standard deviations	Z-values	p-values
Cosmopolitanism	4.6	0.98	22.71	0.000*
Ethnic identity	4.9	0.83	33.31	0.000*

*Significant: $p < 0.05$

High mean values were recorded on both cosmopolitanism (mean = 4.6) and ethnic identity (mean = 4.9), and these means are above the 3.5 expected mean on the six-point scale by a statistically significant ($p < 0.05$) amount. Therefore, the evidence in the sample suggests that Generation Y university students have strong cosmopolitan tendencies, as well as a strong ethnic identity.

Using the 11 official languages to distinguish between cultural groups within South Africa, a one-way MANOVA was conducted to investigate cultural differences in cosmopolitanism and ethnic identity. The non-significant values ($p > 0.05$) computed on the Box test ($p = 0.475$) and Levene's test (cosmopolitanism: $p =$

0.492; ethnic identity: $p = 0.553$) indicate that the data do not violate the assumptions of homogeneity of variance-covariance or the assumption of equality of variance for the two dependent variables. There were no statistically significant differences between the 11 language groups on the combined dependent variables of cosmopolitanism and ethnic identity (Wilks's $\Lambda = 0.942$, $F(20, 760) = 1.50$, $p = 0.293$, partial eta squared = 0.029). Therefore, it appears that South African Generation Y students' levels of ethnic identity and cosmopolitanism are comparable across the county's cultural groups.

In order to assess whether there was a difference between male and female participants' cosmopolitanism and ethnic identity, an independent samples t-test was conducted. The results of this test are reported in Table 4.

Table 4: Gender differences in cosmopolitanism and ethnic identity

	Mean Males N=169	Mean Females N=228	Mean difference	Z-values	p-values
Cosmopolitanism	4.45	4.74	-0.29	-2.94	0.003*
Ethnic identity	4.78	4.96	-0.18	-2.15	0.032*

* Significant: $p < 0.05$

As is evident from Table 4, there is a statistically significant difference between male and female Generation Y students' cosmopolitanism ($p = 0.003 < 0.05$) and ethnic identity ($p = 0.032 < 0.05$). This suggests that in comparison to their male counterparts, female Generation Y students have a stronger ethnic identity and a stronger tendency towards being cosmopolitan.

A correlation matrix was then constructed to determine whether there is a relationship between Generation Y students' cosmopolitanism and ethnic identity, as presented in Table 5.

Table 5: Correlation matrix

	Cosmopolitanism	Ethnic identity
Cosmopolitanism		
Ethnic identity		0.374*

* Significant: $p < 0.05$

As is evident from Table 5, there is a statistically significant positive relationship between Generation Y students' cosmopolitanism and ethnic identity ($r = 0.374$, $p = 0.000 < 0.05$). In line with the findings of Cleveland *et al.* (2011, p.253), this infers the South African Generation Y students' strong ethnic identity harmonises with rather than erodes their tendency towards being cosmopolitan, thereby suggesting that they have a glocal cultural identity.

CONCLUSION

This study sought to determine South African Generation Y university students' tendencies towards ethnic identity and cosmopolitanism, whether there are any cultural or gender differences concerning the two, and whether there is any relationship between these two traits. The findings of the study indicate that South African Generation Y university students have a strong ethnic identity as well as a strong tendency towards being cosmopolitan. While the findings suggest that, in comparison to male participants, female participants have a statistically significant stronger inclination towards both ethnic identity and cosmopolitanism, it appears that there are no significant differences in South African Generation Y students' levels of ethnic identity and cosmopolitanism across the county's cultural groups, as measured by language. The most revealing aspect of the study was that a statistically significant positive correlation coefficient was computed between their ethnic identity and cosmopolitanism. This infers that ethnic identity and cosmopolitanism relate to rather than negate each other, thereby suggesting that South African Generation Y students may be characterised as being glocal in nature. As a glocal market segment, they embrace both a global and ethnic cultural identity. This suggests that

they may be receptive to both global and local brands. However, unlike a global segment, they may exhibit a certain degree of consumer ethnocentrism towards South African brands – something that local brands should capitalise on in their promotional efforts. For international marketers targeting South Africa's Generation Y, it is recommended that they follow the hybrid glocalisation approach. This would entail following a standardised global appeal with certain marketing mix adaptations to suit local market conditions. This may involve, for example, using a global advertising theme but using local models or local celebrity product endorsers and/or translating advertising copy in South Africa's 11 languages. It may involve altering product features, such as adding a news segment dealing with South Africa to a global news channel or changing ingredients, packaging and/or labelling to comply with local laws or tastes. It may also involve following a different pricing or distribution strategy in response to competitive conditions in the local market. Regardless of which marketing mix element is altered, the overall requirement of following the glocalised approach to targeting members of South Africa's Y is to maintain global thinking but adapt to local preferences.

REFERENCES

- Adam, H. (1995). The politics of ethnic identity: Comparing South Africa. *Ethnic and Racial Studies*, 18(3), 457-475.
- Barton, C., Fromm, J. & Egan, C. (2012). The Millennial consumer: debunking stereotypes. The Boston Consulting Group. Available at https://www.bcgperspectives.com/content/articles/consumer_insight_marketing_millennial_consumer/
- Beck, U. & Sznaider, N. (2006). Unpacking cosmopolitanism for the social sciences: a research agenda. *The British Journal of Sociology*, 57(1), 1-23.
- Bevan-Dye, A. L., Garnett, A. & De Klerk, N. (2012). Materialism, status consumption and consumer ethnocentrism amongst black Generation Y students in South Africa. *African Journal of Business Management*, 6(16), 5578.
- Brown, T.A. & Moore, M.T. (2012). Chapter 22: Confirmatory factor analysis. (In Hoyle, R.H., ed. Handbook of structural equation modeling. New York, NY: The Guilford Press. p. 361-379).
- Cleveland, M. & Laroche, M. (2007). Acculturation to the global consumer culture: Scale development and research paradigm. *Journal of Business Research*, 60(3), 249-259.
- Cleveland, M., Papadopoulos, N. & Laroche, M. (2011). Identity, demographics, and consumer behaviors. *International Marketing Review*, 28(3), 244 – 266.
- Douglas, S. P. & Wind, Y. (1987). The myth of globalization. *Columbia Journal of World Business*, 22(4), 19-29.
- Edmunds, J. & Turner, B.S. (2005). Global generations: social change in the twentieth century. *The British Journal of Sociology*, 56(4), 559-577.
- Ger, G. & Belk, R. W. (1996). I'd like to buy the world a coke: Consumptionscapes of the "less affluent world". *Journal of Consumer Policy*, 19(3), 271-304.
- Hair, J.F., Black, W.C., Babin, B.J. & Anderson, R.E. (2010). *Multivariate data analysis: a global perspective*. 7th edition. Upper Saddle River, NJ: Pearson Prentice-Hall.
- King, T.J. (2009). *The war on smokers and the rise of the nanny state*. New York, NY: iUniverse.Inc.

- Kipinis, E., Broderick, A.J. & Demangeot, C. (2014). Consumer multiculturalization: consequences of multi-cultural identification for brand knowledge. *Consumption Markets & Culture*, 17(3), 231-253.
- Kline, R.B. (2011). *Principles and practice of structural equation modeling*. 3rd edition. New York, NY: The Guilford Press.
- Kotler, P. (1986). Global standardization - courting danger. *Journal of Consumer Marketing*, 3(2), 13-15.
- Levitt, T. (1983). The globalization of markets. *Harvard Business Review*, 61(3), 92-102.
- Malhotra, N.K. (2010). *Marketing research. An applied orientation*. 6th edition. Upper Saddle River, NJ: Pearson Prentice-Hall.
- Mareck, M. (2014). Global, Local or Glocal? *Research World*, (45), 26-29.
- Markert, J. (2004). Demographics of age: Generational and cohort confusion. *Journal of Current Issues and Research in Advertising*, 26(2), 11-25.
- Matthews, J. & Sidhu, R. (2005). Desperately seeking the global subject: International education, citizenship and cosmopolitanism. *Globalisation, Societies and Education*, 3(1), 49-66.
- Merton R. (1968). *Social theory and social structure*. New York, NY: The Free Press.
- Pallant, J. (2010). *SPSS Survival Manual*. 4th edition. New York, NY: McGraw Hill.
- Riefler, P. & Diamantopoulos, A. (2009). Consumer cosmopolitanism: Review and replication of the CYMYC scale. *Journal of Business Research*, 62(4), 407-419.
- Robertson, R. (2012). Globalisation or glocalisation? *Journal of International Communication*, 18(2), 191-208.
- Schiffman, L.G., Kanuk, L.L. & Wisenblit, J. (2010). *Consumer Behavior*. 10th edition. Upper Saddle River, NJ, USA: Pearson Prentice Hall.
- Shaw, S. & Fairhurst, D. (2008). Engaging a new generation of graduates. *Education + Training*, 50(5), 366-378.
- Strizhakova, Y., Coulter, R. A., & Price, L. L. (2012). The young adult cohort in emerging markets: Assessing their glocal cultural identity in a global marketplace. *International Journal of Research in Marketing*, 29(1), 43-54.
- Svensson, G. (2002). Beyond global marketing and the globalization of marketing activities. *Management Decision*, 40(6), 574-583.
- Taylor, P. & Keeter, S. (2010). Millennials: a portrait of Generation Next. Pew Research Center, February: 1-140. Available at <http://www.pewsocialtrends.org/files/2010/10/millennials-confident-connected-open-to-change.pdf>
- Webster, C. (1994). Effects of ethnic identification on marital roles in the purchase decision process. *Journal of Consumer Research*, 21(2), 319-331.
- Whittaker, T.A. (2016). Chapter 16: Structural equation modeling. (In Pituch, K.A. & Stevens, J.P., eds. Applied multivariate statistics for social sciences. 6th edition. New York, NY: Routledge. p. 639-733).

ADDRESSING THE AMBIGUITY SURROUNDING CONTEMPORARY GENERATIONAL MEASUREMENT PARAMETERS

Ayesha L. Bevan-Dye
North-West University (Vaal Triangle Campus), South Africa

ABSTRACT

Generational differences are relevant in that they reflect differences in attitudes, values, ambitions and mind-sets between people. From a market segmentation perspective, age is an important segmentation variable. The application of generational theory to market segmentation practices extends the value of age as a segmentation variable to reflect and predict psychographic or lifestyle characteristics. Despite the inherent value of generational theory to segmentation practices, the application thereof is hampered by a lack of consensus concerning contemporary generational parameters. This paper highlights the divergent generational parameters used in the literature to define contemporary generations, with specific reference to Generation Y and justifies the universal acceptance of the generational cohort classification proposed by Markert (2004) for market segmentation purposes.

Keywords: Market segmentation, generational cohorts, generational cohort classification schemes.

INTRODUCTION

Using the German book trade as a case study, Fullerton (2012, p.56) traces the practice of market segmentation back to the 1800s, with the concept first being conceptualised in the literature in 1928. The concept of market segmentation is based on the acceptance that divergent demand is a market characteristic, that distinguishable market segments do exist within the wider heterogeneous market and that it is necessary to adjust marketing strategy elements according to the divergent demands of those distinguishable segments (Smith, 1956, p.4).

The process of segmenting a heterogeneous market involves analysing demographic, psychographic and behavioural differences among potential consumers in a market to identify and profile relatively homogeneous groups of potential consumers (Kotler, 2003, p.9). In line with the fundamental axiom of the marketing concept, the aim of market segmentation is to identify and target those segments of the market that an organisation can effectively and profitably satisfy (Walker & Mullins, 2011, p.14). The key prerequisites for effective market segmentation include using specific criteria to subdivide a heterogeneous market into segments of measurable and clearly identifiable potential consumers who are relatively homogeneous in their needs, desires and likely response to variations in an organisation's marketing efforts, and who are clearly distinguishable from other segments (Walker & Mullins, 2011, p.137; Kotler, 2003, p.286).

There are several criteria that may be used to segment a market, including geographic, psychographic and behavioural variables (Kotler, 2003, p.288). However, demographic variables, which include age, gender, marital status, income, occupation, education level and the like, are generally central to most segmentation schemes, given that these variables are the easiest and most logical method of classifying, measuring and locating groups of individuals (Schiffman, Kanuk & Wisenblit, 2010, p.76). The use of age as a segmentation measure, whether used alone or in conjunction with other demographic variables, offers several advantages in that it is a relatively robust measure of the size of different age groups within a population and is predictive of changes in the demand for many product and service categories linked to lifecycle stages (Markert, 2004, p.11).

The application of generational theory to market segmentation practices extends the value of age as a segmentation variable to reflect and predict psychographic or lifestyle characteristics (Holbrook & Schindler, 1996, p.36), given that generational differences reflect differences in attitudes, values, ambitions and mind-sets (Zemke, Raines & Filipczak, 2013, Chapter 1). Despite the inherent value of segmenting markets on the basis of generational membership, the application thereof is hampered by a lack of consensus in the literature concerning contemporary generational parameters.

The purpose of this paper is to highlight the divergent start and end dates used in the literature to define contemporary generations, with specific reference to Generation Y and to justify the universal acceptance of the generational classification scheme proposed by Markert (2004, p.21) for market segmentation purposes.

LITERATURE REVIEW

A generation refers to the period between birth at a specific historical point and the time it takes to mature and have one's own progeny, so that one generation gives rise to the next generation at regular intervals (Schewe, Debevec, Madden, Diamond, Parment, & Murphy, 2013, p.4). The central axiom of generational theory is that the historical events and social trends that occur during an individual's formative years give rise to a generational consciousness, which shapes the prototypical member of that generation's attitudes, values and behaviour as they move through the trajectory of their lifecycle (Strauss & Howe, 1991, p.32; Mannheim, (1952 [1927], p.290). Even though members of older generations experience the same historical events, it is only when those experiences occur in an individual's formative years that they contribute towards a generational consciousness (Mannheim, (1952 [1927], p.298). This distinguishes between 'contemporaries', which refers to people who are alive at the same time and 'coevals', which refers to people who are of the same age (Eyerman & Turner, 1998, p.93; Ryder, 1965, p.848; Ortega y Gasset, 1961 [1933], p.15), and highlights the definitive effect of shared experiences during youth or the coming of age years of a particular generation (Grasso, 2016, p.40; Wyn & Woodman, 2006, p.498; Ryder, 1965, p.849). These shared life experiences, together with the prevailing social trends encountered during the formative years help shape a generation's attitudes towards family, gender roles, the establishment, risk, culture, values (Strauss & Howe, 1991, p.48), as well as their needs, preferences and consumer behaviour (Schewe & Meredith, 2004, p.52).

According to the literature, there are currently four identified generations and one, as yet, unnamed generation in existence, namely the Silent generation, Baby Boomers, Generation X and Generation Y (Brosdahl & Carpenter, 2011, p.549; Strauss & Howe, 1991, p.36).

While the coming of age years depend on social norms within an era and within a society, the time needed to mature to a young adult is typically taken to be within a year or two of the 20-year mark (Markert, 2004, p.20). With the exception of a few outliers, the sample of studies reported in Table 1 suggests that the length of a generation is typically within a few years of the 20 year mark, with the average being 17.5 years. However, that being said, there is significant discourse in the literature as to when contemporary generation cycles begin and how long each lasts. This is evident from the sample of generational measurement parameters in the literature presented in Table 1.

Table 1: Sample of measurement parameters for contemporary generations

	Silent	Boomer	Gen X	Gen Y
Lancaster & Stillman, 2002	-	1946-1964	1965-1980	1981-1999
Schewe & Meredith, 2004	-	1946-1965	1966-1976	-
Oblinger <i>et al.</i> , 2005	-	1946-1964	1965-1982	1982-1991
Martin, 2005	-	-	-	1978-1988
Shi & Allen, 2007	-	-	-	1977-1994 or 1982-2003
Howe & Strauss, 2007	1925-1942	1943-1960	1961-1981	1982-2005
Cennamo & Gardner, 2008	1925-1945	1946-1961	1962-1979	1980-2000
Codrington, 2008	1929-1945	1946-1967	1968-1989	1989-2005
Hurst & Good, 2009	1925-1945	-	-	1980-2003
Reisenwitz & Iyer, 2009	-	1946-1964	1965-1976	1977-1988

Schiffman <i>et al.</i> , 2010	-	1946-1964	1965-1979	1977-1994 or 1982-2000
Twenge <i>et al.</i> , 2010	1925-1945	1946-1964	1965-1981	1982-1999
Brosdahl & Carpenter, 2011	1925-1945	1943-1960	1961-1981	1982-2000
Murray <i>et al.</i> , 2011	1925-1945	1946-1964	1965-1981	1982-1994
Jain & Pant, 2012	1922-1945	1946-1964	1965-1980	1980-2000
Zemke <i>et al.</i> , 2013	-	1943-1960	1960-1980	1980-2004
PEW Research, 2014	1928-1945	1946-1964	1965-1980	1981-1996

As shown Table 1, with the exception of Howe and Strauss (2007), most authors put the end date of the Silent generation as 1945 and the start date ranging by seven years from 1922 to 1929, with 1925 being the most common start date. There is a great deal more consensus concerning the start and end dates of the Baby Boomer generation, which are generally taken to be 1946 and 1964, although certain authors put these dates as 1943 to 1960 (Zemke *et al.*, 2013; Brosdahl & Carpenter, 2011; Howe & Strauss, 2007). The real confusion starts with the divergent generational parameters used to define Generation X, a problem that intensifies with the demarcation of Generation Y. In 2017, the oldest members of Generation X may be anywhere between 49 to 57 years of age (a difference of eight years) and the youngest between 28 and 41 years (a difference of 12 years). Similarly, the oldest members of Generation Y may be anywhere between 28 to 40 years of age (a difference of 13 years) and the youngest between 12 and 29 years (a difference of 17 years). This confusion is also reflected in articles in the media. For example, in the USA's New York Times, Generation Y is defined as including individuals born between 1980 and 1995 (Williams, 2015), in the UK's Telegraph as including individuals born between 1980 and 2000 (Wallop, 2014) and in South Africa's Moneyweb as including individuals born between 1982 and 2003 (Duncan, 2014). While some academic authors acknowledge this dispute before selecting the generational parameters that suit their particular study (Bolton, Parasuraman, Hoefnagels, Migchels, Kabadayi, Gruber, Loureiro & Solnet, 2013, p.247; Fochte, Schloffler, Maloles, Chia, 2009, p.223), others use the generational labels but blithely omit to indicate to whom they are referring (O'Cass & Choy, 2008, p.341). Still others select a specific age category that they vaguely suggest is part of a specific generation is the assumed hope that it will fit with someone's definition of that generation (Gustin & Ha, 2014, p.82; Ma & Niehm, 2006, p.621). Even respected marketing-related textbooks appear to grapple with the issue. For example, Schiffman *et al.* (2010, p.410) offer two alternative date ranges for Generation Y and then include individuals that are too young to be part of either date ranges in their sub-classification of Generation Y. A marketing practitioner seeking guidance from published academic studies on the use of generations in market segmentation may well be forgiven for being sceptical as to the value of such studies if marketing academics themselves are unable to reach consensus concerning the demarcation of contemporary generations.

Markert (2004, p.20) contends that this discourse in the literature is the result of the confusion surrounding the meaning of a generation and a generational cohort. Edmunds and Turner (2002, p.1, 6) indicate that in conventional social science, a generation is viewed as an age stratification of a society, as a driver of social change brought about by traumatic events or as a cyclical occurrence caused by intergenerational conflict over resources and power. Ryder (1965, p.844, 845), who follows the demographic approach to generations, asserts that cohorts are the aggregate of individuals born within a specified time interval who experience the same events, moods and trends at similar stages of their lives; that is, they occupy a "unique location in the stream of history" that differentiates them from members of other cohorts. Strauss and Howe (1991, p.39, 60, 62) argue that generational change is cyclical in that each new generation of youths attempts to correct or compensate for the perceived mistakes of the midlife generation in power at the time. They take the stance that a generation is a cohesive group with its own unique peer personality brought about by shared experiences during the formative years, whose length approximates the different phases of life, which they divide into 22-year phases. They add that each generation includes an early and late cohort, whose birth dates differ by approximately 10 years. This notion of intergenerational conflict is similar to Boudieu's (1993, p.101) conceptualisation of generation formation arising from a clash between the youth and older generations over resources and power. Schewe and Noble (2000, p.130) argue that whereas a generation refers to the approximately 20 years it takes individuals born in a specific year to achieve adult status, a cohort is only formed when significant external events occur during the formative years and, as such, may be any length of time, even longer than a generation. Following this logic, they identify six distinct cohorts that range in length from five to 17 years and include the Depression cohort (1912-1921), the World War II cohort (1922-1927), the Post-War

cohort (1928-1945), Leading-Edge Boomer cohort (1946 -1954), the Trailing-Edge Boomer cohort (1955-1965) and the Generation X cohort (1966-1976). In a more recent paper, the lead author, Charles Schewe, indicates the start date of the Generation Y cohort as 1981 (Schewe *et al.*, 2013, p.5), which raises an interesting question concerning what happened to the individuals born between 1977 and 1980.

This discourse as to what is a generation and what is a generational cohort, when each begins and how long each lasts explains the confusing array of generational parameters that appear in the literature. However, Turner (2002, p.15) indicates that it is important to integrate generational and cohort analysis in order to understand how different generations impact on society.

Markert (2004, p.20, 25) agrees that generations may typically be thought of as being approximately 20 years in length but, following Ryder's (1965, p.851) logic, counters that a generational cohort and, by implication, a generational consciousness still exists even if the formative years were merely marked by certain social trends rather than traumatic and/or significant historical events. Following this rationale also takes into account the cyclical nature of generational change. This reasoning follows Turner's (2002, p.15) assertion that the temporal location of a cohort dictates the "opportunities, chances and resources" available to that cohort, resulting in members of different cohorts facing "radically different issues and life chances" during the formative years.

Given that there is a great deal of consensus regarding the measurement parameters delineating the Baby Boomers, Markert (2004, p.21) defines generations in 20-year increments starting with the most widely cited start date for that generation, namely 1946. Using this 20-year marker, he then moves back in time to define the Silent generation (1926-1945) and forward in time to define Generation X (1966-1985) and Generation Y (1986-2005). He then subdivides each generation into 10-year cohorts representing the early and later members of each generation, which coincides with what Strauss and Howe (1991, p.62) term as the first and last wave cohorts of a generation. He indicates that these cohorts may then be further subdivided into five-year groups, which he names bihorts, in order to finer tune segmentation efforts. Table 1 outlines the generation cohort classification as proposed by Markert (2004).

Table 2: A generational cohort classification

Generations	Cohorts	Bihorts
Silents: 1926-1945	Early Silents: 1926-1935 Late Silents: 1936-1945	Early-early Silents: 1926-1930
		Late-early Silents: 1931-1935
		Early-late Silents: 1936-1940
		Late-late Silents: 1941-1945
		Early-early Boomers: 1946-1950
Boomers: 1946-1965	Early Boomers: 1946-1955 Late Boomers: 1956-1965	Late-early Boomers: 1951-1955
		Early-late Boomers: 1956-1960
		Late-late Boomers: 1961-1965
		Early-early X-ers: 1966-1970
		Late-early X-ers: 1971-1975
X-ers: 1966-1985	Early X-ers: 1966-1975 Late X-ers: 1976-1985	Early-late X-ers: 1976-1980
		Late-late X-ers: 1981-1985
		Early-early Gen Y: 1986-1990
		Late-early Gen Y: 1991-1995
		Early-late Gen Y: 1996-2000
Gen Y: 1986-2005	Early Gen Y: 1986-1995 Late Gen Y: 1996-2005	Late-late Gen Y: 2001-2005

Source: Markert (2004, p.21)

This classification of generations put forward in Table 1 helps to encapsulate the unique challenges and opportunities associated with specific generations, generational cohorts and generational bihorts, thereby facilitating market segmentation efforts. The use of these definitive 20-year markers makes it clear which generation is being referred to in studies, which will aid marketing practitioners in better understanding the characteristics of the different generations. This also facilitates the study of intergenerational differences, as well as enables comparisons between generations residing in different countries for international segmentation efforts.

Where necessary, the 10-year cohorts and five-year bihorts allow for finer-tuned segmentation efforts. This cohort and bihort division also make provision for potentially disruptive historical events. In this regard, such a classification scheme enables predictive rather than reactive generational segmentation in that it allows marketers to trace influencing events and trends during a generation, cohort or bihort's formative years in order to better pinpoint their likely consumer behaviour. Another important aspect of this scheme is that the late-late bihorts facilitate understanding of what Lancaster and Stillman (2002, p.36) identified as cuspers; that is, individuals who stand at the cusp of two generations and who are old enough to relate to the values and attitudes of their own generation but young enough to embrace the spirit of the new generation.

CONCLUSION

The disagreement surrounding generational measurement parameters is a contentious issue but, nonetheless, an issue that needs to be addressed. The application of generational theory to market segmentation practices extends the value of age as a segmentation variable to reflect and predict salient psychographic or lifestyle characteristics in terms of differences in attitudes, values, ambitions, mind-sets and consumer behaviour. However, the lack of consensus concerning what constitutes a generation and a generational cohort, when each begins and how long each lasts has led to a confusing range of generational parameters in the literature, bringing its application validity to marketing practitioners into question. The generation classification scheme developed by Markert (2004, p.21) offers an eloquent solution. By offering 20-, 10- and five-year parameters, this scheme allows for ever finer-tuned market segmentation efforts. The use of definitive measurement parameters not only establishes who precisely are being referred to in studies pertaining to specific generations but also allows for comparative studies between generations and between generations in different countries. From a marketing perspective, possibly the most important benefit of this scheme is that it provides the date parameters for investigating and making predictions about the consumer behaviour of the next generation. As the oldest members of the next generation turn 11 in 2017, it will be interesting to trace the effect of factors such as trends towards artificial intelligence and virtual reality, the growing scarcity of natural resources, as well as the dichotomy between ever increasing globalisation and the wave of nationalism that is re-emerging across the globe on their consumption attitudes and preferences.

REFERENCES

- Bolton, R.N., Parasuraman, A., Hoefnagels, A., Migchels, N., Kabadayi, S., Gruber, T., Loureiro, Y.K. & Solnet, D. (2013). Understanding Generation Y and their use of social media: a review and research agenda. *Journal of Service Management*, 24(3), 245-267.
- Bourdieu, P. (1993). *Sociology in question*. Trans. Richard Nice. London: Sage.
- Brosdahl, D. J., & Carpenter, J. M. (2011). Shopping orientations of US males: A generational cohort comparison. *Journal of Retailing and Consumer Services*, 18(6), 548-554.
- Cennamo, L. & Gardner, D. (2008). Generational differences in work values, outcomes and person-organisation values fit. *Journal of Managerial Psychology*, 23(8), 891 – 906.
- Codrington, G. 2008. Detailed introduction to generational theory. *Tomorrow Today*. Available at http://www.tomorrowtoday.uk.com/articles/article001_intro_gens.htm
- Duncan, F. (2014). South Africa's Millennials: What do they want? *Moneyweb*, 7 May. Available at <https://www.moneyweb.co.za/archive/sa-continues-to-diverge-from-the-rest-of-africa/>
- Edmunds, J. & Turner, B.S. (2002). Introduction: Generational consciousness, narrative and politics (*In* Edmunds, J. & Turner, B.S., eds. *Generational consciousness, narrative and politics*. Lanham: Rowman & Littlefield. p. 1-12).

- Eyerman, R. & Turner, B.S. (1998). Outline of a theory of generations. *European Journal of Social Theory*, 1(1): 91-106.
- Fochte, T., Schloffer, J., Maloles, C. & Chia, S.L. (2009). Assessing the outcomes of Generation-Y customers' loyalty. *International Journal of Bank Marketing*, 27(3), 218-241.
- Fullerton, R.A. (2012). The historical development of segmentation: the example of the German book trade 1800-1928. *Journal of Historical Research in Marketing*, 4(1), 56 – 67.
- Grasso, M.T. (2016). *Generations, political participation and social change in Western Europe*. New York, NY, USA: Routledge.
- Gustin, L. & Ha, Y. (2014). Effect of environmental product information and ethnicity on Millennials' brand attitude and purchase intention. *International Journal of Science Commerce and Humanities*, 2(6), 77-88.
- Howe, N. & Strauss, W. (2007). The next 20 years: how customer and workforce attitudes will evolve. *Harvard Business Review*, July-August: 1-12.
- Hurst, J. L., & Good, L. K. (2009). Generation Y and career choice: the impact of retail career perceptions, expectations and entitlement perceptions. *Career Development International*, 14(6), 570-593.
- Jain, V., & Pant, S. (2012). Navigating Generation Y for Effective Mobile Marketing in India: A Conceptual Framework. *International Journal of Mobile Marketing*, 7(3), 56-65.
- Kotler, P. (2003). *Marketing Management*. 11th edition. Upper Saddle River, NJ, USA: Prentice Hall.
- Lancaster, L.C. & Stillman, D. (2002). *When Generations Collide: Who They Are. Why They Clash. How to Solve the Generational Puzzle at Work*. New York, NY: Harper Collins Publishers.
- Ma, Y.J. & Niehm, L.S. (2006). Service expectations of older generation Y customers: An examination of apparel retail settings. *Managing Service Quality*, 16(6), 620-640.
- Mannheim, K. (1952 [1927]). The problem of generations. (In Kecskemeti, P., ed. *Essays on the sociology of knowledge*. London: Routledge. p. 276-320.).
- Markert, J. (2004). Demographics of age: generational and cohort confusion. *Journal of Current Issues and Research in Advertising*, 26(2): 11-25.
- Martin, C. A. (2005). From high maintenance to high productivity: What managers need to know about Generation Y. *Industrial and Commercial Training*, 37(1), 39-44.
- Murray, K., Toulson, P. & Legg, S. (2011). Generational cohorts' expectations in the workplace: A study of New Zealanders. *Asia Pacific Journal of Human Resources*, 49(4), 476-493.
- Oblinger, D., Oblinger, J. L. & Lippincott, J. K. (2005). *Educating the Net generation*. Brockport Bookshelf. Book 272. Available at <http://digitalcommons.brockport.edu/bookshelf/272>
- O'Cass, A. & Choy, E. (2008). Studying Chinese generation Y consumers' involvement in fashion clothing and perceived brand status. *Journal of Product & Brand Management*, 17(5), 341-352.
- Ortega y Gasset, J. (1961[1923]). *The modern theme*. Trans. James Cleugh. New York, NY: Harper.
- Pew Research Center. (2014). Millennials in adulthood: Detached from institutions, networked with friends. *Pew Research Center*, 7 March. Available at <http://www.pewsocialtrends.org/2014/03/07/millennials-in-adulthood/>

- Ryder, N.B. (1965). The cohort as a concept in the study of social change. *American Sociological Review*, 30(6): 843-861.
- Schewe, C.D., Debevec, K., Madden, T.J., Diamond, W.D., Parment, A. & Murphy, A. (2013). If you've seen one, you've seen them All! Are young Millennials the same worldwide? *Journal of International Consumer Marketing*, 25(1): 3-15.
- Schewe, C.D. & Meredith, G.E. (2004). Segmenting global markets by generational cohorts: determining motivations by age. *Journal of Consumer Behaviour*, 16(1-3): 51-63.
- Schewe, C.D. & Noble, S.M. (2000). Market segmentation by cohorts: the value and validity of cohorts in America and abroad. *Journal of Marketing Management*, 16(1-3): 129-142.
- Schiffman, L.G., Kanuk, L.L. & Wisenblit, J. (2010). *Consumer Behavior*. 10th edition. Upper Saddle River, NJ, USA: Pearson Prentice Hall.
- Shih, W. & Allen, M. (2007). Working with Generation-D: adopting and adapting to cultural learning and change. *Library Management*, 28(1/2), 89-100.
- Smith, W.R. (1956). Product differentiation and market segmentation as alternative marketing strategies. *Journal of Marketing*, 21(1), 3-8.
- Stauss, W. & Howe, N. (1991). *Generations: the history of America's future, 1584 to 2069*. New York, NY: Harper.
- Turner, B.S. (2002). Strategic generations: historical change, literacy expressions, and generational politics (*In* Edmunds, J. & Turner, B.S., eds. *Generational consciousness, narrative and politics*. Lanham: Rowman & Littlefield. p. 13-29).
- Twenge, J.M., Campbell, S.M., Hoffman, B.J. & Lance, C.E. (2010). Generational differences in work values: leisure and extrinsic values increasing, social and intrinsic values decreasing. *Journal of Management*, 36(5): 1117-1142.
- Walker, O.C. & Mullins, J.W. (2011). *Marketing Strategy: A Decision-Focused Approach*. 7th edition. New York, NY, USA: McGraw-Hill Irwin.
- Wallop, H. (2014). Gen Z, Gen Y, baby boomers – a guide to the generations. *Telegraph*, 31 July. Available at <http://www.telegraph.co.uk/news/features/11002767/Gen-Z-Gen-Y-baby-boomers-a-guide-to-the-generations.html>
- Williams, A. (2015). Move over, Millennials, here comes Generation Z. *New York Times*, 18 September. Available at https://www.nytimes.com/2015/09/20/fashion/move-over-millennials-here-comes-generation-z.html?_r=0
- Zemke, S., Raines, C. & Filipczak, B. (2013). *Generations at work: Managing the clash of Boomers, Gen Xers, and Gen Yers in the workplace*. 2nd edition. New York, NY: American Management Association. [Electronic book].

JOB STRESSORS AND BURNOUT IN FIELD OFFICERS OF MICROFINANCE INSTITUTIONS IN INDIA: ROLE OF WORK-RELATED RUMINATION

Nidhi S. Bisht
MDI Gurgaon, India

ABSTRACT

This paper seeks to examine the effect of perceived job stressors - work overload, role conflict, and emotional demands on burnout in field officers of Microfinance Institutions (MFIs) in India. It further explores the mediating role of work related rumination (affective rumination and problem solving pondering) in the relationship between the perceived job stressors and burnout. The author draws upon empirical self-reported data collected from 297 field officers from India by administering a questionnaire. Hierarchical regression analyses and a series of structural equation modeling analyses were used for hypotheses testing. Consistent with predictions, the findings showed that perceived job stressors, work related rumination- affective rumination, and problem solving pondering were significantly related to burnout. Moreover, affective rumination partially mediated the relationship between job stressors and burnout in the expected direction. However, the study provided only partial support for problem solving pondering as a mediator in the aforesaid relationship.

Keywords: Job Demands, field officers, Microfinance Institutions (MFIs), burnout, work-related rumination, India

INTRODUCTION

Microfinance is delivered to under-privileged clients through field officers, who play a critical role in the delivery of services by acting as a mediator between the organization and poor clients (Goetz, 2001; Siwale and Ritchie, 2012). Unfortunately, these officers work in a difficult work environment and are confronted with various job stressors to maintain quality of services (Ahmad, 2002; Gray, 2013; Holtmann and Grammling, 2005; Siwale, 2016). Despite the criticality of role of field officers, in the functioning of microfinance, so far, fewer studies have focused on the experiences of field officers (Siwale and Ritchie, 2012; Siwale, 2016). Though prior research has offered some evidence of job stressors faced by field officers, to date; no study has analysed how these job stressors affect the well-being of field officers'. Taking view of the aforesaid gap, the study aims to examine the impact of perceived job stressors on burnout; which has long been recognized as a social problem by researchers and practitioners, implying significant cost at individual and organizational level (e.g. Schaufeli et al., 2009). There is a real need for a study in this area, considering the pivotal role played by field officers in facilitating sustainable growth of MFIs (Shchetinin and Wollbrant, 2013; Siwale, 2016) and the fact that human service workers particularly may be at a greater risk of burnout (Boyas and Wind, 2010; Campbell et al., 2013).

Within stress-strain-coping framework (Hobfoll, 1989; Lazarus, 1999; Lazarus and Folkman, 1984), it has long been argued that stress is an outcome of a psychologically mediated process and the impact of job stressor depends on the way it is taken by the person. In this regard, there has been a recent surge of academic interest in the way stressful work environment may 'spill over' into off job time, making some people engage in perseverative thinking or work-related rumination (Cropley and Millward, 2009; Querstret et al., 2015). Cropley and Zijlstra (2011) conceptualized work-related rumination as repetitive thoughts, related to work. They categorized work related rumination as affective rumination and problem-solving pondering, on the basis of emotional arousal. In the affective state, psychological and physiological arousal remains high, and is cognitively and emotionally intrusive, thus negative affecting employees' well-being (Querstretand Cropley, 2012; Rawal, Park and Williams, 2010; Syrek and Antoni, 2014). On the other hand, problem solving state exists without psycho physiological arousal; hence it is less

detrimental for recovery or may have positive impact on the person's well being, especially when problem-solving pondering, helps in finding solution to a problem (Cropley and Zijlstra, 2011; Querstret and Cropley, 2012). Given this, type of rumination, could be a significant mediating variable in the relationship between job stressors and psychological health outcomes (Hamesch et al., 2014). Based on this line of argument, the study investigates the mediating role of affective rumination (a maladaptive function) and problem-solving pondering (an adaptive function) in the relationship between job stressors and burnout.

THEORETICAL FRAMEWORK AND HYPOTHESES

Job stressors and burnout in field officers of MFIs

A bulk of scholarly contributions on stressor–strain literature, has widely acknowledged that job stressors may evoke job burnout in employees (Bakker and Demerouti, 2007; Hakanen et al., 2006; Lee and Ashforth, 1996). Specific to the study, are the job stressors characterized by work overload, role conflict and emotional demands to which field officers are exposed during their work.

Work overload represents a condition when individuals perceive themselves as having insufficient time or energy, to comfortably fulfil job expectations imposed upon them (Voydanoff, 2002). Field officers manage various aspects of micro-lending like screening potential clients, loan applications; providing training; preparing reports; pursuing defaulters and taking follow-up on repayments (Holtmann and Grammling, 2005; Labie et al., 2009; Gray, 2013). Not only this, in a quest to boost growth, organizations force these so called agents of change, to push their financial performance and impose pressures of deadlines, quotas and loan recovery (Puhazhendhi, 2013; Sarker, 2013). As a result, they have to often work beyond normal work hours and compensate for support staff in case of shortfalls (Puhazhendhi, 2013). For all these reasons, much of the research on field officers is pronounced by its emphasis on the work overload experienced by them (Baumann, 2005; Kar, 2013). A significant body of literature has identified work overload to be positively related to burnout (e.g. Bakker et al., 2003; Cordes and Dougherty, 1993). Given the empirical basis, the following hypothesis was proposed for the study:

Hypothesis 1(a). Perceived work overload is positively related to burnout (1a)

Role conflict is defined as incongruence in expectations; so that the compliance with one makes it difficult to comply with the other (Peterson *et al.*, 1995; Rizzo *et al.*, 1970). In delivering micro financial services, field officers perform multiple changeable roles of loan repayment agents, debt collectors and participative facilitators (Dixon, Ritchie, and Siwale, 2007; Kar, 2013; Siwale and Ritchie, 2012). Typically, in this process they simultaneously work as a facilitator, personal advisor, counselor, money manager and even a conflict mediator (Ito, 2003). On the one hand organizations expect them to increase loan disbursement and outreach; and on the other, clients, who are in a state of crisis or problem, expect compassion and sensitivity (Siwale and Ritchie, 2012). These work realities impose conflicting demands on field officers, often leaving them disillusioned in this apparently so called 'noble' work (Siwale, 2016). The incompatibility between the roles leads to inherent discomfort to balance role requirements. Consistent with literature identifying role conflict as an antecedent to burnout (Burke and Greenglass, 1993; Jawahar, Stone and Kisamore, 2007); it's hypothesized that:

Hypothesis 1(b). Perceived role conflict is positively related to burnout.

Emotional demands are generally defined as the display of particular types of emotions in line with the organizational 'display rules' during interactions with clients, for improved job outcomes (Hochschild, 1983). Microfinance services, by its nature involve a direct contact with clients on the ground. During interactions with clients, field officers are expected to express a variety of emotions to show empathy (Canales, 2014) which helps to better understand needs, preferences, and problems of clients. The interpersonal exchanges with clients are often emotionally charged one, which calls for regulation of feelings and expressions for developing relational ties, and trust (Dixon, Ritchie and Siwale, 2007; Goetz, 2001; Jain and Moore, 2003; Siwale and Ritchie, 2012). A growing body of literature has revealed that emotional demands often exhaust self-regulatory resources which negatively affect

employees' well being. Emotional demands have been found to be an antecedent to burnout (e.g. Bakker and Heuven, 2006; Brotheridge and Grandey, 2002). Hence, following was hypothesized:

Hypothesis 1(c). Perceived emotional demands are positively related to burnout.

Work-related rumination and burnout

Transactional theory (Lazarus, 1999; Lazarus and Folkman, 1984) provides theoretical framework to discern the role of work-related rumination in the job stressors–burnout relationship. Transactional theory argues that ‘psychological stress refers to a relationship with the environment that the person appraises, as significant for his or her well-being and in which the demands tax or exceed available coping resources’ (Lazarus and Folkman 1986, p.63). In other words, we can say that, any external stimulation in itself is not inherently stressful; rather, stress is a relational concept, determined by the subjective cognitive judgement that arises from the interaction between the person and the external stimulation. When employees face job stressors at work, they may expend physical and mental energy, to cope with these stressors (Cropley and Millward, 2009). During off-job time, rumination may be one such way of coping, when employees may ruminate about past work issues or prospectively think about future demands that may arise at work (Cropley et al., 2006; Cropley and Zijlstra, 2011). Interestingly, work-related rumination may be positive or negatively valenced, depending on the physiological arousal (Cropley and Zijlstra, 2011).

In line with transactional theory, if rumination is affective in nature, people experience physiological arousal, which may not allow them to derive benefits of off-job time (Cropley and Millward, 2009; Kuper and Marmot, 2003); thereby leading to resource depletion, without any replenishment. This reasoning is also compatible with the COR theory (Hobfoll, 1989; 2002); according to which individuals seek to acquire, maintain, and protect resources, and consider prospective threat to resources (like objects, conditions, or internal attributes) as stressful. Hence, the cycle of resource loss, gain, and protection plays an important role in explaining burnout (Hobfoll, 1989; 2002). Therefore, burnout may develop from a process, when there is resource drain without any replenishment or counterbalancing resource gain (Gorgievski and Hobfoll, 2008). In the affective state, since psychological and physiological arousal remains high; it is cognitively and emotionally intrusive, thereby adding to the process of resource depletion. This position has been supported by past research, where affective rumination is said to be negatively related to health and wellbeing (Cropley et al., 2016; Hecht and Boies, 2009). Based on the above arguments, it's reasonable to posit that:

Hypothesis 2. Affective rumination is positively related to emotional exhaustion (2a) and depersonalization (2b)

Hypothesis 3. Affective rumination partially mediates the relationship between work overload and emotional exhaustion (3a); emotional demands and emotional exhaustion (3b); and role conflict and emotional exhaustion (3c).

Hypothesis 4. Affective rumination partially mediates the relationship between work overload and depersonalization (4a); emotional demands and depersonalization (4b); and role conflict and depersonalization (4c).

Problem-solving pondering conversely occurs without psychophysiological arousal, since people enjoy the experience, without being 'switched-on' (Cropley and Zijlstra, 2011). This sometimes may provide new insights and solutions to the problems, hence wrapping up the ruminative process (Meier et al., 2016; Querstret and Cropley, 2012). Indeed, reflection (similar to problem-solving pondering) has been found to facilitate problem solving and reduce burnout in employees (Fritz and Sonnentag, 2005; Treynor et al., 2003). Building upon transactional theory and COR theory (Hobfoll, 2002), it can be posited that since problem-solving pondering does not involve psychophysiological arousal, it helps to offset the job-related psychological and physiological costs of emotional demands and improves constructive coping. Thus problem solving pondering could act as a buffer to the extent; it either reduces loss of resources or enables gain of other resources. From a conceptual point of view, it is also likely that problem solving pondering could mediate the effect of job stressors on burnout. It's hypothesised that:

Hypothesis 5. Problem solving pondering is negatively related to emotional exhaustion (5a) and depersonalization (5b).

Hypothesis 6. Problem-solving pondering partially mediates the relationship between work overload and emotional exhaustion (6a); role conflict and emotional exhaustion (6b); emotional demands and emotional exhaustion (6c).

Hypothesis 7. Problem-solving pondering partially mediates the relationship between work overload and depersonalization (7a); role conflict and depersonalization (7b); emotional demands and depersonalization(7c).

METHOD

Procedure and subjects

The sample for the study was drawn from the list of MFIs in India (The Bharat Microfinance Report, 2015, p.94). A total of 297 employees completed both survey forms, which were usable for analyses. The respondents' age ranged between 20 and 35 years with senior secondary or higher education.

*Measures:*All measures (survey questions) were administered in English.

Job stressors (work overload and emotional demands and Role conflict): Work overload (6 items; $\alpha=0.72$), and emotional demands(5 items; $\alpha=0.82$) were measured using adapted scales from the Veldhoven and Meijman's(1994) questionnaire on the experience and assessment of work(QEAW). Sample items were Do you have too much work to do and Does your work put you in emotionally upsetting situations? forwork overload and emotional demands respectively. The third job stressor role conflict was measured with 8-item scale of Rizzo et al., (1970). Sample item include, I work under incompatible policies and guidelines.The internal consistency (Chronbach's alpha) for this scale was 0.78. Respondents reported their answers on a 5-point likert scale with anchors ranging from strongly disagree to strongly agree.

Work-related rumination: Work-related rumination was assessed using two scales (each with 5 items) of the Work-Related Rumination Questionnaire (Cropley et al., 2012). The internal consistency (Chronbach's alpha) for affective rumination and problem-solving pondering were 0.87 and 0.83 respectively. The affective rumination scale included items such as Do you become tense when you think about work-related issues during your free time? The problem-solving pondering scale included items such as After work I tend to think about how I can improve my performance. Rumination items were scored on a 5-point scale ranging from 1 (Very seldom/never) to 5 (Very often/always).

Burnout: Given that the manifestation of distinct dimensions of burnout may be concurrent instead of a sequential, distinct dimension were chosen over a composite scale (Jawahar et al., 2007). Emotional exhaustion (8 items) and depersonalization (5 items), were used from the Maslach Burnout Inventory–Human Services Survey (MBI–HSS; Maslach et al., 1996). Example items from these scales included items such as I feel emotionally drained from my work (exhaustion) and I don't really care what happens to some of my clients (depersonalization). All burnout items were scored on a 7-point scale ranging from 0 (never) to 6 (always) with Cronbach's α equal to 0.79 and 0.85 for emotional exhaustion and depersonalization, respectively.

Control variables: To avoid spurious relations between the variables, control variables (gender, marital status, job tenure, and total experience) were included in the study.

RESULTS

Preliminary analyses

Table 1 reports means, standard deviations, inter-correlations, and internal consistencies (chronbach's alpha) of all the variables in this study. Control variables are also shown in descriptive statistics, following recommendations of Becker (2005).

Table 1: Means, Standard Deviations, and Correlations between the Model Variables

	Mean	SD	1	2	3	4	5	6	7	8	9	10
1. Gender	1.12	0.32										
2. Marital status	1.70	0.50	0.00									
3. Tenure	3.41	1.4	-0.00	.12*								
4. Work overload	3.64	0.67	0.08	0.00	0.12*	(0.72)						
5. Role conflict	3.42	0.77	0.13**	-0.06	0.08	0.36***	(0.78)					
6. Emotional demands	2.98	0.94	0.14**	0.00	0.03	0.23***	0.22**	(0.82)				
7. Affective rumination	2.91	1.01	0.08	0.16**	0.21***	0.38***	0.36***	0.36***	(0.87)			
8. Problem solving pondering	3.12	1.02	-0.06	0.04	-0.14**	0.22***	0.43***	0.19***	0.45***	(0.83)		
9. Emotional exhaustion	3.20	0.82	0.11*	0.14**	0.13**	0.51***	0.47***	0.50***	0.48***	-0.42***	(0.79)	
10. Depersonalization	2.97	0.93	0.09	0.17***	0.22***	0.44**	0.42***	0.48***	0.52***	-0.59***	0.68***	(0.85)

Notes: n=297, *p < .05, **p < .01, ***p < 0.001. Reliability coefficients are on the diagonal in parentheses. Control variables: Gender, marital status, tenure. Study variables: Work overload, Role conflict, Emotional demands, Affective rumination, Problem solving pondering, Emotional exhaustion, Depersonalization

Table 2: Results of structural equation modeling analyses: Fit Indices of Models

Model	χ^2	df	GFI	CFI	RMSEA
M1	1273.79	570	0.93	0.95	0.05
M2	1482.61	580	0.82	0.89	0.08
M3	2109.93	622	0.63	0.71	0.10
M4	3074.58	625	0.50	0.50	0.13

Notes: df, degrees of freedom; GFI, Goodness-of-Fit Index; CFI, Comparative Fit Index; and RMSEA, Root Mean Square Error of Approximation.

Measurement models were fitted to the data to ensure the adequacy of all constructs in the model and their use for further analyses. Model M1 with 7 factors (work overload, role conflict, emotional demands, affective rumination, problem solving pondering and burnout) with all items loading on to their respective factors provided a good fit to the data ($\chi^2=1273.79$, $df=570$; $p<0.001$; $\chi^2/df=2.23$; $GFI=0.93$; $CFI=0.95$; $RMSEA=0.05$). Importantly, M1 provided a better fit to the data than M2, a 6 factor model ($\chi^2=1482.61$, $df=580$, $p<0.001$; $\Delta\chi^2=208.82$, $\Delta df=10$; $\chi^2/df=2.55$; $GFI=0.82$; $RMSEA=0.08$; $CFI=0.89$) with affective rumination and problem solving pondering loading on to one factor; and M3, a 5 factor model ($\chi^2=2109.93$, $df=622$, $p<0.001$; $\chi^2/df=3.39$; $GFI=0.63$; $AGFI=0.58$; $RMSEA=0.10$; $CFI=0.71$) where affective rumination and problem solving pondering and were loaded to one factor. All other models including M4, one factor model ($\chi^2=3074.58$, $df=625$, $p<0.001$; $\chi^2/df=4.91$; $GFI=0.50$; $AGFI=0.44$; $CFI=0.50$; $RMSEA=0.13$) where all the constructs were collapsed into one factor, showed a poor-fit to the data signifying that 7 factor model is the best fit to the research data.

Hypotheses testing and Discussion

Hypotheses 1, 2, and 5 were tested using a multiple regression approach in which the control variables (gender, marital status, job tenure, and total experience) were entered in the first step; and the predictor variables (work overload, emotional demands, role conflict, affective rumination and problem solving pondering) were entered in the next step. To check that multicollinearity did not bias the regression analyses, variance inflation factor (VIF) and tolerance statistics were checked. Analyses revealed acceptable limits i.e., $VIF<10$ and tolerance $>.1$ as suggested by Field (2009). Table III shows the results for emotional exhaustion. All the Control variables entered in step 1 variables accounted for 4.7% of variance and were the significant predictors of emotional exhaustion. The predictor variables entered in step 2 accounted for 54.8% of variance with work overload ($\beta=0.30$, $p<0.001$); role conflict ($\beta=0.32$, $p<0.001$); and emotional demands ($\beta=0.19$, $p<0.001$) contributing significantly to the prediction of emotional exhaustion.

Table 3: Results of Multiple regression for variables predicting emotional exhaustion

	Step 1		Step 2	
	β	t	β	t
1. Gender	0.11	2.29*	-0.00	-0.23
2. Marital Status	0.12	2.52*	0.14	4.13***
3. Tenure	0.12	2.4*	0.01	0.27
4. Work overload			0.30	7.70***
5. Role conflict			0.32	8.61***
6. Emotional demands			0.19	4.78***
7. Affective Rumination			0.20	6.61***
8. Problem solving pondering			-0.18	-4.60***
Adjusted R ²	0.03		0.53	
ΔR^2	0.04		0.50	
ANOVA F	6.30***		57.81***	

Notes: *p < .05, **p < .01, ***p < 0.001.

Table 4 shows the results for depersonalization. The predictor variable entered in step 2 accounted for 73.2% of the variance with work overload ($\beta=0.12$, $p < 0.001$); role conflict ($\beta=0.22$, $p < 0.001$) and emotional demands ($\beta=0.19$, $p < 0.001$) significantly predicting depersonalization. In summary, hypotheses 1(a); 1(b) and 1(c) are fully supported. Furthermore, affective rumination and problem solving pondering predicted the outcome in the expected direction Affective rumination was positively related to emotional exhaustion ($\beta=0.20$, $p < 0.001$) and depersonalization ($\beta= 0.46$, $p < 0.001$) thereby supporting hypotheses 2a and 2b respectively. As hypothesised, problem solving pondering was negatively related to emotional exhaustion ($\beta= -0.18$, $p < 0.001$) and depersonalization ($\beta= -0.29$, $p < 0.001$); thereby fully supporting hypotheses 5(a) and 5(b).

Table 4: Multiple regression for variables predicting depersonalization

	Step 1		Step 2	
	β	t	β	t
1. Gender	0.10	2.06*	-0.00	-0.30
2. Marital Status	0.15	3.09*	0.11	4.03***
3. Tenure	0.20	4.10***	0.03	1.34
4. Work overload			0.12	4.2***
5. Role conflict			0.22	7.5***
6. Emotional demands			0.19	6.09***
7. Affective Rumination			0.46	13.56***
8. Problem solving pondering			-0.29	-9.32***
Adjusted R ²	0.07		0.72	
ΔR^2	0.08		0.65	
ANOVA F	11.38***		129.79***	

Notes: *p < .05, **p < .01, ***p < 0.001.

Next, mediation analyses were performed in order to assess the mediating role of affective rumination and problem-solving pondering (Preacher and Hayes, 2008). The results of mediation analyses are presented in Table 5. With significant indirect effect affective rumination partially mediated the relationship between work overload ($\beta = 0.06$; $p < 0.01$); role conflict ($\beta = 0.09$; $p < 0.01$); emotional demands ($\beta = 0.07$; $p < 0.01$) and emotional exhaustion thereby fully supporting hypotheses 3(a), 3(b) and 3(c) respectively. The indirect effects correspond to the influences that the independent variables (IVs) exert on the dependent variable (DV) through the mediator. A similar pattern of relations were found in predicting depersonalization. With significant indirect effect affective rumination also partially mediated the relationship between work overload ($\beta = 0.14$; $p < 0.01$), role conflict ($\beta = 0.12$; $p < 0.01$), emotional demands ($\beta = 0.07$; $p < 0.01$); and depersonalization thereby fully supporting hypotheses 4(a), 4(b) and 4(c) respectively.

Table 5: Summary of mediation results for emotional exhaustion and depersonalization with work overload, role conflict and emotional demands as independent variables.

Relationship/hypothesis	Direct beta without mediator	Direct beta with mediator	Indirect beta	Mediation type observed
WO AR EE	0.41***	0.35***	0.06**	Partial mediation
RC AR EE	0.29***	0.23***	0.09**	Partial mediation
ED AR EE	0.30***	0.04(NS)	0.07**	Partial mediation
WO AR DEP	0.31***	0.15***	0.14**	Partial mediation
RC AR DEP	0.23***	0.17***	0.12**	Partial mediation
ED AR DEP	0.30***	0.04(NS)	0.07**	Partial mediation
WO PSP EE	0.41***	0.34***	-0.00(NS)	No mediation
RC PSP EE	0.32***	0.21***	0.03(NS)	No mediation
ED PSP EE	0.31***	0.19***	0.08**	Partial mediation
WO PSP DEP	0.31***	0.16***	-0.01(NS)	No mediation
RC PSP DEP	0.28***	0.18***	-0.09**	Partial mediation
ED PSP DEP	0.30***	0.04(NS)	0.07**	Partial mediation

Notes: ** $p < .01$; *** $p < 0.001$

WO, Work Overload; RC, Role Conflict; ED, Emotional Demands; Mediator, AR, Affective Rumination; PSP, Problem Solving Pondering; NS, Not Significant

However, with Non Significant (NS) indirect effect, problem-solving pondering did not mediate the relationship between work overload ($\beta = -0.00$; NS), role conflict ($\beta = 0.03$; NS) and emotional exhaustion, failing to support hypotheses 6(a) and 6(b). Interestingly, with significant indirect effect ($\beta = 0.08$; $p < 0.01$), problem-solving pondering mediated the relationship between emotional demands and emotional exhaustion but not in the expected direction, thereby providing partial support for hypothesis 6(c).

With Non Significant indirect effect ($\beta = -0.01$; NS) problem solving pondering did not mediate the relationship between work overload and depersonalization, failing to support hypothesis 7(a). With significant indirect effect ($\beta = -0.09$; $p < 0.01$) problem solving pondering mediated the relationship between role conflict and depersonalization in the expected direction, fully supporting hypothesis 7(b). Like emotional exhaustion, problem solving pondering significantly mediated the relationship between emotional demands ($\beta = 0.07$; $p < 0.01$) and depersonalization but not in the expected direction, providing partial support for hypothesis 7(c).

The findings corroborate and build on previous research indicating prevalence of burnout in human service professionals (e.g. Boyas and Wind, 2010; Campbell et al., 2013). The results of the study, also confirmed the mediating role of affective rumination as a cognitive process in the relationship between job stressors and burnout. It follows that the experiences of work overload, role conflict and emotional demands at workplace and may lead to affective rumination; which in turn may exacerbate burnout due to depletion of resources in the absence of adequate recovery. We may posit that indulgence in affective rumination imposes additional emotional and cognitive demands on employees, exhausting employees' mental and physical resources (Hobfoll, 2002). The findings align with previous studies showing that indulgence in recurrent affective work-related thoughts is cognitively and emotionally intrusive and impedes the process of recovery, leading to negative health outcomes (Cropley and Zijlstra, 2011; Cropley and Millward, 2009; Fritz and Sonnentag, 2005; Nolen-Hoeksema et al., 2008).

Problem solving pondering was significantly negatively related to emotional exhaustion and depersonalization but the effect was stronger for depersonalization. The results supported the view that rumination is not necessarily a negative process, detrimental to recovery, but one its type can be an adaptive coping strategy (Arditte and Joormann, 2011; Cropley and Zijlstra, 2011; Pravettoni et al., 2007). However, contrary to the hypothesis, the results of this study provided only partial support for problem-solving pondering as a mediator in the relationship between job stressors and burnout - emotional exhaustion and depersonalization. While problem-solving pondering did not mediate the relationship between work overload; role conflict and emotional exhaustion, it partially mediated

the relationship between emotional demands and emotional exhaustion, ironically in a reverse direction of causality. Problem solving pondering, did not mediate the relationship between work overload and depersonalization. Interestingly, it partially mediated the relationship between role conflict and depersonalization, in the expected direction; and between emotional demands and depersonalization, in the reverse direction of causality.

One possible reason of problem solving pondering affecting burnout positively, could be that while trying to seek solutions for problems due to emotional demands experienced at work, employees may not be able to find solutions and hence are not able to abandon concerns, thereby consequently engaging in affective rumination (Papageorgiou and Wells, 2003). Thus, problem-solving pondering may gradually change into affective rumination over a period of time, thereby negating the positive effects of the adaptive form of rumination (Aldao and Nolen-Hoeksema, 2012; Takano and Tanno, 2009). The fact that problem-solving pondering, played a protective role in the relationship between role conflict and depersonalization, supported the findings that problem solving pondering may reduce the negative effects of job stressors (Arditte and Joormann, 2011; Cropley and Zijlstra, 2011).

LIMITATIONS AND FUTURE RESEARCH DIRECTIONS

Some limitations are warranted and should be taken into consideration before generalizing the findings of the present study. First, the findings on postulated relationships cannot be regarded as conclusive given the cross-sectional nature of research, which limits the degree to which causality can be inferred. The use of a longitudinal study design in the future might better explain the causal role of job stressors, affective rumination and problem solving pondering, in triggering emotional exhaustion and depersonalization. Second, the data on the study variables were self-reported; therefore common method bias (Podsakoff et al., 2003; 2012) may have partially accounted for the result. However, this bias should have been minimized since antecedents were separated from outcomes in the survey, and respondents were ensured anonymity and confidentiality for their responses. Also, the study was presented as an exploration of job-related attitudes which affected their off-job time, and there was no direct reference of burnout in the study information. Still, the possibility of common method bias cannot be completely ruled out. Future validation studies may consider employing mix method designs (e.g., Denzin, 1970). Third, since affective rumination and problem-solving pondering (to some extent) were the partial mediators in the relationship between job stressors and burnout, the role other similar constructs, like worry and anxiety (Watkins, 2008), could be explored as potential partial mediators explaining the central relationship.

REFERENCES

- Arditte. B. and Joormann. J. (2011). Emotion regulation in depression: reflection predicts recovery from a major depressive episode. *Cognitive Therapy and Research*, 35,536-543.
- Bakker. A. B. and Demerouti. E. (2007). The job demands-resources model: state of the art. *Journal of Managerial Psychology*,22, 309-328.
- Bakker. A. B.,Demerouti.E., De Boer. E. and Schaufeli. W. B. (2003). Job demands and job resources as predictors of absence duration and frequency. *Journal of Vocational Behavior*, 62 ,341-356.
- Baumann. T. (2005). Pro-poor microcredit in South Africa: Cost-efficiency and productivity of South African pro-poor microfinance institutions.*ESR Review*,7,97-119.
- Becker. T. E. (2005). Potential problems in the statistical control of variables in organizational research: A qualitative analysis with recommendations. *Organizational Research Methods*, 8, 274-289.
- Bentler. P. M. (1990). Comparative fit indexes in structural models. *Psychological bulletin*, 107, 238-246.
- Boyas. J. and Wind. L. H. (2010). Employment-based social capital,job stress,and employee burnout: A public child welfare employee structural model.*Children and Youth Services Review*, 32, 380–388.

- Brotheridge. C. M. and Grandey. A. A. (2002). Emotional labor and burnout: Comparing two perspectives of people work. *Journal of Vocational Behavior*, 60, 17-39.
- Burke. R.J. and Greenglass. E. (1993). Work stress,role conflict,social support,and psychological burnout among teachers. *Psychological Reports*,73,371-380.
- Byrne. B. M. (2010). *Structural equation modeling with AMOS: Basic Concepts. Applications.and Programming*. 2nd ed.. Taylor and Francis. New York.
- Campbell.N.S.. Perry.S.J..Maertz Jr.C.P.. Allen. D.G. and Griffeth. R.W. (2013). All you need is... resources: The effects of justice and support on burnout and turnover. *Human Relations*, 66,759-782.
- Cropley. M. and Millward. L. J. (2009). How do individuals 'switch-off' from work during leisure? A qualitative description of the unwinding process in high and low ruminators. *Leisure Studies*, 28, 333-347.
- Cropley. M. and Zijlstra. F. R. H. (2011). Work and rumination.inLangan-Fox. J. and Cooper.C.. *Handbook of stress in the occupations*. Edward Elgar.U.S.A , 487-503.
- Cropley.M.,Dijk. D. J. and Stanley. N. (2006). Job strain,work rumination,and sleep in school teachers. *European Journal of Work and Organizational Psychology*, 15, 181-196.
- Cropley.M.,Michalianou. G. Pravettoni. G. and Millward. L. (2012). The relation of post work ruminative thinking with eating behavior. *Stress and Health*, 28, 23-30.
- Cropley.M.,Zijlstra. F. R.,Querstret. D. and Beck. S. (2016). Is work-related rumination associated with deficits in executive functioning?,*Frontiers in Psychology*, 7, 1524.
- Dixon.R., Ritchie. J. and Siwale. J. (2007). Loan officers and loan 'delinquency' in microfinance: a Zambian case. *Accounting Forum*, 31, 47-71.
- Field. A. (2009). *Discovering Statistics Using SPSS*. Sage Publications. London.
- Fritz. C. and Sonnentag. S. (2005). Recovery,health,and job performance: effects of weekend experiences. *Journal of Occupational Health Psychology*, 10,187-199.
- Goetz. A.M. (2001). *Women Development Workers: Implementing Rural Credit Programmes in Bangladesh*. Sage Publishing. New Delhi.
- Gorgievski. M. J. and Hobfoll. S. E. (2008). Work can burn us out or fire us up: Conservation of resources in burnout and engagement.in Halbesleben. J.R.B.*Handbook of Stress and Burnout in Health care*. Nova Science Publishers. New York., 7-22.
- Hair. J. F.. Black. W. C.,Babin. B. J., Anderson. R. E. and Tatham. R. L. (2006). *Multivariate Data Analysis*. 6th ed.. Pearson Education. New Jersey.
- Hakanen. J. J., Bakker. A. B.,andSchaufeli. W. B. (2006). Burnout and work engagement among teachers.*Journal of School Psychology*, 43, 495-513.
- Hamesch.U.,Cropley. M. and Lang. J. (2014). Emotional versus Cognitive Rumination: Are They Differentially Affecting Long term Psychological Health?. *The Impact of Stressors and Personality in Dental Students*. *Stress and Health*, 30,222-231.
- Hecht.T.D.,andBoies. K. (2009). Structure and correlates of spillover from nonwork to work: An examination of nonwork activities,well-being,and work outcomes. *Journal of Occupational Health Psychology*,14 , 414 – 426.

- Hobfoll. S. E. (1989). Conservation of resources: A new attempt at conceptualizing stress. *American Psychologist*, 44, 513-524.
- Hobfoll. S. E. (2002). Social and psychological resources and adaptation. *Review of General Psychology*, 6, 307-324.
- Hobfoll. S.E. (2002). Social and psychological resources and adaptation. *Review of General Psychology*, 6 4., 307-324.
- Hochschild. A. R. (1983). *The Managed Heart-Commercialization of Human Feeling*. 20th ed.. University of California. Berkeley. CA.
- Holcombe. S. H. (1995). *Managing to Empower: the Grameen Bank's Experience of Poverty Alleviation*, Zed Books, London.
- Hsu. B.Y. (2014). Alleviating poverty or reinforcing inequality? Interpreting micro-finance in practice.with illustrations from rural China. *The British Journal of Sociology*, 65, 245-265.
- Ito. S. (2003). Microfinance and social capital: does social capital help create good practice?. *Development in Practice*, 13, 322-332.
- Jain. P. and Moore. M. (2003). What makes Microcredit Programmes Effective? Fashionable fallacies and workable realities. Working paper [177]. Institute of Development Studies. England. January.
- Jawahar.I.M.. Stone. T.H. and Kisamore. J.L. (2007). Role conflict and burnout: The direct and moderating effects of political skill and perceived organizational support on burnout dimensions. *International Journal of Stress Management*, 14, 142-159.
- Kuper. H. and Marmot. M. (2003). Job strain.job demands.decision latitude.and risk of coronary heart disease within the Whitehall II study. *Journal of Epidemiological Community Health*, 57 2., 147 – 153.
- Lazarus. R. and Folkman. S. (1984). *Stress. Appraisal.and Coping*. Springer. New York.
- Lazarus. R. S. (1999). *Stress and Emotion: a new Synthesis*. Free Association. London.
- Lee. R. T. and Ashforth. B. E. (1996). A meta-analytic examination of the correlates of the three dimensions of job burnout. *Journal of Applied Psychology*, 81, 123-133.
- Maslach. C. Jackson. S. E. and Leiter. M. (1996.). *Maslach Burnout Inventory: Manual*. 3rd ed.. Consulting Psychologists Press. Palo Alto. CA.
- Meier L. L.. Cho E. and Dumani S. (2016). The effect of positive work reflection during leisure time on affective well-being: results from three diary studies. *Journal of Organizational Behaviour*, 37, 255–278.
- Nolen-Hoeksema.S.. Wisco. B. E. and Lyubomirsky. S. (2008). Rethinking rumination. *Perspectives on Psychological Science*, 3, 400-424.
- Papageorgiou. C. and Wells. A. (2003). An empirical test of a clinical metacognitive model of rumination and depression. *Cognitive Therapy and Research*, 27, 261-273.
- Pravettoni.G..Cropley.M..Leotta. S. N. and Bagnara. S. (2007). The differential role of mental rumination among industrial and knowledge workers. *Ergonomics*, 50, 1931-1940.
- Preacher. K. J. and Hayes. A. F. (2008). Asymptotic and resampling strategies for assessing and comparing indirect effects in multiple mediator models. *Behavior Research Methods*, 40, 879-891.

- Puhazhendhi. V. (2013). *Microfinance in India: State of the Sector Report*. 2012. ACCESS Development Services. Sage. New Delhi.
- Querstret D., Cropley M., Kruger P. and Heron R. (2015). Assessing the effect of cognitive behaviour therapy (CBT)-based workshop on work-related rumination, fatigue, and sleep. *European Journal of Work and Organizational Psychology* 25, 50–87.
- Querstret. D. and Cropley. M. (2012). Exploring the relationship between work-related rumination, sleep quality and work-related fatigue. *Journal of Occupational Health Psychology*, 17, 341-353.
- Rawal. A., Park. R. J. and Williams. J. M. G. (2010). Rumination, experiential avoidance, and dysfunctional thinking in eating disorders. *Behaviour Research and Therapy*, 48, 851-859.
- Rizzo. J.R., House. R.J. and Lirtzman. S.I. (1970). Role conflict and ambiguity in complex organizations. *Administrative Science Quarterly*, 15, 150-163.
- Sarker. D. (2013). Pressure on loan officers in microfinance institutions: An ethical perspective. *Journal of Economics and Sustainable Development*, 84-88.
- Schaufeli. W.B., Leiter. M.P. and Maslach. C. (2009). Burnout: 35 years of research and practice. *Career Development International*, 14, 204-220.
- Shchetinin. O. and Wollbrant. C. (2013). The intermediary role of microloan officers: Evidence from Ethiopia. *Working Papers in Economics* [581]. University of Gothenburg, School of Business, Economics and Law, Gothenburg. December.
- Siwale. J. (2016). Microfinance and loan officers' work experiences: perspectives from Zambia. *The Journal of Development Studies*, 52, 1289-1305.
- Siwale. J. N. and Ritchie. J. (2012). Disclosing the loan officer's role in microfinance development. *International Small Business Journal*, 30, 432-450.
- Taka K. and Tan Y. (2009). Self-rumination, self-reflection, and depression: self-rumination counteracts the adaptive effect of self-reflection. *Behaviour Research and Therapy*, 47, 260-264.
- The Bharat Microfinance Report (2015). Sa-Dhan. The Association of Community Development Finance Institutions, New Delhi.
- Treynor. W., Gonzalez. R. and Nolen-Hoeksema. S. (2003). Rumination reconsidered: A psychometric analysis. *Cognitive Therapy and Research*, 27, 247-259.
- Van Veldhoven. M. & Meijman. T. (1994) Het meten van psychosociale arbeidsbelasting met een vragenlijst: de Vragenlijst Belevingen Beoordeling van de Arbeid (VVBA) [Measurement of psychosocial job demands with a questionnaire: The questionnaire experience and evaluation of work (VBBA)]. Amsterdam
- Voydanoff. P. (2002). Linkages between the work-family interface and work, family, and individual outcomes. *Journal of Family Issues*, 23, 138-164.
- Watkins. E.R. (2008). Constructive and unconstructive repetitive thought. *Psychological Bulletin*, 134, 163-206.
- Zellars. K. L. and Perrewé. P. L. (2001). Affective personality and the content of emotional social support: coping in organizations. *Journal of Applied Psychology*, 86, 459-467.

FLIPPING INNOVATIVE TEACHING AND LEARNING ON ITS HEAD: A HYBRID MODEL FOR UNDERGRADUATE BUSINESS MANAGEMENT EDUCATION AT A SOUTH AFRICAN UNIVERSITY

D.A.J. Bornman

University of Pretoria, Republic of South Africa

Department of Business Management

ABSTRACT

This study focuses on the current instructional mixed methods utilised at a tertiary education institution in South Africa. It investigates the development of various approaches pertaining to teaching and learning and tries to identify which elements from which approaches should and should not be included to form a hybrid teaching and learning model. Approaches such as the traditional classroom, active learning, the flipped classroom and blended learning, together with elements that focus on millennials and the role of technology, are discussed. Preliminary findings indicate that successful implementation has positive effects on the students and lecturers.

Keywords: Hybrid, blended, flipped classroom, teaching and learning, business management, university, tertiary education, South Africa.

INTRODUCTION

In modern day tertiary academic environments, students tend to view the university module Business Management as “theoretically overloaded and uninteresting”. Specifically in a South African context and on an undergraduate level, this module has accumulated a very specific negative image over the past 20 years due to its low pass rates, limited student engagement and a fundamental lack of radical and continuous sustainable innovation (i.e. from teaching and learning issues to classroom experiences). As learning is a lifelong process where information is transformed into knowledge, skills and attitudes (Erasmus, Loedolf, Mda & Nel, 2013, p. 126), it is imperative that these aspects towards a module such as Business Management should be positive in order to achieve student and lecturer success. Parslow (2012: p. 337) however points out that traditional lecturing approaches move too slow for high-achieving students and the low-achieving students must move on to the next work without understanding the previous concepts.

A key objective of tertiary level teaching and learning processes has developed into how to overcome the tribulations of students’ learning experiences. Zayapragassarazan and Kumar (2012, p. 3), point out that learners do not learn accurately when they sit passively in classes listening to the lecturer, instead the learners should engage in discussion. Issues such as teaching and learning innovation, immense class sizes, high lecturer/student ratios (i.e. 1:350) and consequently low congruence between teaching and learning styles, have established a critical disequilibrium which needs to be addressed.

Although moving away from the traditional classroom might be an answer, merit can be found within the learner centred traditional classroom, as it focuses on the learning abilities of the learners (i.e. students) and how they participate in the work they are being taught. If learner centred traditional classroom elements can be combined or fused with active learning, students can possibly have a more in depth and positive perspective on business management lectures or classes.

Zayapragassarazan and Kumar (2012:3) points out that active learning is when an environment is created where learners can read, listen write and engage in class discussions that can result in learning that can be applied throughout their lives. Pardo, Sanagustin, Parada and Leony (2012, p. 1) refers to active learning as the most

effective participation strategy that will lead to an improvement in the learning experience. These authors also add that active learning can be considered as anything course-related that all students in a class session are called upon to do, other than simply watching, listening and taking notes.

In the context of this study, millennials are the main focus group and they can be described as individuals that were born between 1981 and 1999 who were exposed to technology at a very young age (Warnich, Carrell, Elbert & Hatfield, 2013, p. 185). Millennials are also known as Generation Y and are individuals that thrive on technology that is highly collaborative, they prefer group problem solving and learning with their peers, and they have access to unlimited information which makes them prefer to use this technology to communicate (Gillispie, 2016, p. 32; Warnich *et al.*, 2013, p. 185).

To motivate and engage students in lectures have always been important but this has now grown to become one of the most critical challenges of the 21st century. Li, Qi, Wang and Wang (2014:48) argue that today's students rely on computers to do their work, as they live in the technology age. These students rely on digital technology and Holmes, Tracy, Painter and Oestreich (2015, p. 215) depict digital technology as hardware and software solutions of which laptops, desktops, tablets and smart phone computing devices are the most frequently used in learning environments. According to Prensky (2010, p. 2) the student's tolerance and needs changed, learners can sit for extensive periods playing or working on a computer, but find difficulty to concentrate in class and listening to lectures.

Taking cognisance of this, an approach such as the flipped classroom has gained popularity over the past couple of years due to classroom activities and homework being switched around. The flipped classroom approach argues that, instead of students sitting in a classroom and listening to a lecture, pre-recorded videos are created by the lecturers that assist students to engage with the textbook theory of a subject before they attend class (i.e. a class in a physical building where the lecturer is present) (Milman, 2012, p. 83; O'Flaherty & Philips, 2015, p. 185). Thus a class that is successfully flipped will challenge the critical thinking abilities of students and will increase student engagement in and outside the class (O'Flaherty & Philips, 2015, p. 85).

Due to this, the flipped classroom approach was introduced at a South African tertiary institution (i.e. a university in South Africa) as a way to better engage students. Much of what happened inside the classroom now happens outside of the classroom. Students are required to read theory prior to coming to the classroom and are given supporting material in the form of practical case studies or theory discussion videos created by the lecturer.

The flipped classroom approach has created changes towards Business Management as an academic module, but as this approach has merely been incremental by improving the components of teaching and learning and leaving the system of academic knowledge sharing and understanding unchanged, the need for radical innovation has emerged. This type of innovation, where both the components of teaching and learning and the system of academic knowledge sharing and understanding needs to be new, has given rise to the need of a hybrid teaching and learning model.

At the foundation for this hybrid teaching and learning model, the flipped classroom approach has assisted to further develop this new model where science of learning meets the art of teaching. This is done by harnessing technology in such a way where aspects such as teaching and learning excellence, affordability and access, and effective digital transformation enablement, assists the lecturers to equip students to be successful. The teaching and learning within and outside the classroom now creates a deeper connection between students, their lecturers and also the academic work.

PROBLEM STATEMENT

As current tertiary institutions are experiencing difficult times by staying connected with students or letting students truly 'practice' the textbook theory in modules such as Business Management, it has become evident that a change is needed. This change is one that will have to support the current teaching and learning models but which will have to assist students, as well as lecturers, to effectively communicate the textbook theory in such ways that makes the work more interesting, understandable, technologically relevant and pro-active.

RESEARCH AIM

The overall aim of the research paper is to quantitatively analyse the experience of the undergraduate Business Management students utilising newly developed radical innovation which is a hybrid teaching and learning model. Furthermore this research aim is closely linked to identifying, developing and implementing a best practice hybrid teaching and learning model that can assist students, as well as lecturers, to effectively communicate the textbook theory in such ways that makes the work more interesting, technologically relevant, innovative and encourages millennials to be pro-active instead of reactive.

BENEFITS AND IMPORTANCE OF THE STUDY

The main benefit of the study is that if proven successful, it will assist to increase student participation, which in turn will improve the learning, the attitude and performance of students that may result in a higher pass rate (Downs & Wilson, 2015, p. 261). As this century's learners are used to multitasking they tend to have shorter attention spans (Warnich *et al.*, 2013, p. 185) and thus instead of sitting in a classroom with limited attention they can engage with various approaches without necessarily having to be in a physical classroom (i.e. watch a lecturer's pre-recorded theory discussion videos at their own pace). The lecturer will then be able to use the class time to assist with homework or class activities and explain difficult concepts in order to control and eliminate learning stumbling blocks for the students (Alvarez, 2011).

LITERATURE REVIEW

The Traditional Classroom

Park and Choi (2014, p. 749), state that the medieval universities were the first to arrange desks in a classroom in two linear rows, with a lecturer, whose main function was to deliver knowledge, through reading to the students. The traditional classroom is teacher-centred, and the lecturer provides information through instruction in a classroom with chalk, blackboard and multimedia while the students sit at desks, behind each other, facing the front of the classroom where practical work follows the lesson where they are taught (Alhasani, 2015). Goldsmith (2014, p. 30) refers to this method as the teach-push approach where there is only one-way communication, where the lecturer provides the students with the content which is highly controlled and predictable. Weigel and Bonica (2014, p. 21) state that this traditional approach of lecturing may not be the ideal way to provide information to students to learn and retain the content.

Goldsmith (2014, p. 30) is of the opinion that in the traditional classroom, the lecture can be effective in the lower levels of Bloom's Taxonomy such as remembering and understanding but that it is not effective for the higher levels of intellectual exertion such as applying, analysing, evaluating and creating. Al-Zahrani (2015, p. 1133) points out that higher order thinking skills of students should be enhanced to prepare the students for the changing demands of the new millennium.

In the sense of the traditional classroom, after the lecture, homework is given which the student will have to do at home (Erasmus *et al.*, 2013:115). Basal (2015, p. 28) indicates that the work that is limited to classroom hours is one of the limitations of the traditional classroom, and that basic level skills are taught in the classroom and then the students have to work on the higher level skills on their own in their own time in the form of homework. Davis (2016, p. 228) underlines this limitation by pointing out that students must then work at home on their own, without any assistance on activities that typically fall under the higher levels of Bloom's Taxonomy of application, analysis evaluation and creation.

The introduction of technology delivered a new generation of students, known as the millennials who are different and do not have patients for lectures, but who prefer to do rather than being told what to do (Prensky, 2001, p. 1).

The Millennials

Millennials, are also referred to as Generation Y, (Warnich *et al.*, 2013:185), the Net Generation (Net Gen) (Maurtin-Cairncross, 2014, p. 564) and digital natives (Prensky, 2001, p. 1) and are individuals that were born between 1981 and 1999 (Warnich *et al.*, 2013, p. 185). They are the most recent generation of four generations, where a generation is referred to as a group of people that belong in a certain category, and who are influenced by the way they process information by their shared experiences (Gillispie, 2016, p. 32).

According to Warnich *et al.*, (2013, p. 185), millennials have their own sets of opinions, ideas, manners, attitudes, motivators and expectations. These authors also identified certain characteristics of millennials, which include that millennials: (1) are digitally literate (i.e. comfortable with using technology and has been using it from a very young age), (2) can multitask (i.e. they move quick from one activity to another and can perform several tasks simultaneously), (3) have a need for immediacy (i.e. they demand fast responses and place more value on speed than accuracy), (4) have a need for experiential learning (i.e. they prefer to learn by doing instead of being told what to do), (5) are social (i.e. open to diversity and prefer social learning), (6) have a preference for group work (i.e. prefer to work in groups and collaborate with their peers), (7) want to have structure in their learning (i.e. learning should be goal orientated), (8) prefer images instead of text (i.e. they do not enjoy reading large amounts of text), and (9) are community minded (i.e. prefer to work on things that matter which can resolve difficult problems).

Maurtin-Cairncross (2014, p. 564) argues that the characteristics and preferences of the millennials are good indicators that millennials do not do things the same way than the previous generation. In research done by Early (2016, p. 139) it is pointed out that the ways lectures were presented in the previous decade is not relevant anymore and that students prefer to rather engage in discussions instead of listening to lecturers or reading from books.

Active Learning

To engage millennial learners, lecturers started to follow different approaches like incorporating active learning into the learning experience (Roehl, Reddy & Shannon, 2013, p. 45). According to Zayapragassaran and Kumar (2012, p. 13) active learning refers to learners engaging themselves in the learning experience through listening, talking, reading, writing, reflecting and applying what they have learned.

For active learning to take place in class time lecturers can use technology to record videos and other interactive elements which the learners can watch before going to class (Basal, 2015, p. 28). Thus the twenty first century learner prefers active collaboration and communication that is promoted by new technology (Holmes *et al.*, 2015, p. 215) and this then according to Basal (2015, p. 28) creates limitless and borderless opportunities in education.

The Development And Role Of Technology

Li *et al.*, (2014, p. 48) point out that the information technology age that we live in dominates higher education, which leads to more knowledgeable and experienced learners. They further state that using technology such as smart phones, iPads and laptops to watch videos, do online quizzes, listen to recorded audio and using online resources on the internet enhances critical and innovative thinking. As stated by Lai and Hong (2015, p. 725), 74% of learners prefer image, multimedia and videos instead of text.

Johnston and Karafotias (2016, p. 226) state that in their opinion, the advantages outweigh the disadvantages but the biggest challenge remains that the lecturer has to be innovative to find ways in which he or she can get the students to watch the videos before class.

The Flipped Classroom

Basal (2015, p. 29) states that the flipped classroom approach consists of watching videos of a recorded lecture before a lesson where after class time is spend on engaging the student in activities, discussion and clarifying concepts and investigation content related questions. Bishop and Verleger (2013, p. 5) reiterates this by defining the flipped classroom as a two part educational technique, where part one is in classroom, interactive activities in groups and part two consist of computer based instructions, including videos outside the classroom. Thus the students do their class work at home and their home work in class, instead of listening to a lecture, they watch the recorded lecture (i.e. this could be in the form of a video- or an audio recording) at home and participate in class activities when they attend their contact session (i.e. when students attend their classes) (Herreid & Schiller, 2013, p. 62).

According to Enfiel (2013, p. 15) the flipped classroom approach is an effective way of assisting learners to learn content and increase the ability of the learner to work independently. Duxbury, Gainor and Trifts, (2016, p. 40) also state that in contrast to the traditional classroom approach, a flipped classroom approach is when the lecturer will take the first few minutes to reinforce the knowledge that the student gained from watching a content video at home, where after the students will take part in discussions in groups to find possible solutions to problems.

Blended Learning

Blended learning is an approach that incorporates both face-to-face and online activities in a course or module (Margolis, Porter & Pitterle, 2017, p. 1). This also means that more time needs to be taken outside of the class to prepare for class than for a traditional face-to-face lecture. According to Lee, Lau and Yip (2016, p. 168), blended learning approaches have become increasingly common in tertiary education around the world and these approaches often involve the use of self-directed learning materials delivered through a learning management system or platform to supplement face-to-face teaching.

Specifically focusing on higher education institutions, Wong, Tatnall and Burgess (2014, p. 239) developed a theoretical framework which provides a blended learning overview. This framework highlights certain critical elements that need to be evident in a blended learning approach and include: (1) readiness (i.e. institution readiness, staff readiness and student readiness), (2) intensity of adoption (i.e. blended learning options and the selection of options), and (3) impact (i.e. the quality of learning achieved).

Most significant is the fact that blended learning provides flexible teaching and learning options for lecturers and students, in comparison to the traditional face-to-face approach (Sivapalan, 2017, p. 10). This also creates the opportunity to include different aspects of learning management tools such as blogs, quizzes, journals, online discussions, virtual lectures and activities, e-portfolios, and feedback.

RESEARCH METHODOLOGY

In order to identify, develop and implement a hybrid teaching and learning model, it is critical to take cognisance of the research that has been used to form the current tertiary educational environment. Therefore, approaches such as the traditional classroom, active learning, the flipped classroom and blended learning needs to be positioned in terms of millennials and be linked to the role of current technology.

Taking the study's concepts and constructs into account, a survey was developed focusing on the experiences of current students at a South African university in terms of the various mixed instructional methods (i.e. educational approaches) that have been implemented in the business management courses. A link to an online survey questionnaire was then distributed to students on a learning management platform (i.e. Google+) which investigates the experiences of undergraduate students utilising the current mix of education approaches (i.e. elements of the traditional classroom, active learning, the flipped classroom and blended learning). Participation was not compulsory and a total of 433 students participated.

Furthermore this also focused on aspects such as: (1) observation and tracking of virtual interaction amongst students and lecturers, (2) monitoring the frequency of use in terms of online interaction, participation and enjoyment, and (3) ease, accessibility and comprehension. In terms of ethical considerations participants of the study electronically gave their consent by continuing with the online questionnaire. Participants in the study did not receive any incentives (i.e. monetary or non-monetary) to motivate them to participate.

PRELIMINARY FINDINGS

As this research is still in progress but preliminary finding indicate that class attendance and student enrolment numbers in the undergraduate Business Management courses did not drop as with the traditional classes. Seeing that this approach is more interactive, the confidence levels of students increased and allowed for more lecturer-student engagement. Along with this there was more peer engagement and it also provided a platform where a student's voice was as powerful outside of the classroom as it is in the classroom.

Furthermore the following results were also identified: (1) the coefficient had a high correlation with adoption rates, implying that a number of users accepted the platform for its multidimensional purpose/s, (2) the E & F students (i.e. with an average of between 30% and 49%) did not effectively engage in online learning support (i.e. some students would blame newness/new technology for low marks), and (3) 3112 emails were addressed and channelled away from the inbox of the lecturer (i.e. students assisted their peers with answering questions and coming up with solutions to problems).

The pass rate, as well as the academic average of students within this undergraduate business management course showed positive results by indicating that the pass rate went from 89% (2015) to 91% (2016), the average went from 58% (2015) to 67% (2016). A conversion rate of 91% was achieved in the first month by going from a traditional classroom approach to a more integrated hybrid model and an enormous adoption rate of 90% was achieved in the first month (2015) to 92% (2016) in the first week.

DISCUSSION

As this study focuses on research that is currently being conducted and is longitudinal, it is important to note that the development of a hybrid teaching and learning model is still in progress. This would mean that the current findings might change as rapidly as the technology that forms its basis. Although this has to be taken into consideration, it is evident that the current need indicates that a hybrid teaching and learning model should consist of various, already identified aspects. Aspects that form part of this model should include, but are not limited to: (1) co-creation, (2) it should be web-based, (3) immediacy and speed, (4) monitoring, (5) peer tutoring, (6) multi-media integrated, (7) to be a free platform that is utilised, (8) assessment, (9) adaptive learning and (10) that class attendance should be encouraged. One very important part of making a hybrid teaching and learning model function successfully, is that of integrated comprehensive understanding which will entail that everyone involved (i.e. the lecturer and the students) be trained correctly in implementing, administrating, and further developing the model implemented, in order to ensure relevancy and sustainability.

REFERENCES

- Alhasani, H. M. A. (2015). Design and Precept of a Flipped Classroom Style and Its Impact on Traditional Education. Available: <http://ieeexplore.ieee.org/document/7210350/>. [Last accessed: 1 March 2017].
- Alvrez, B. (2011). Flipping the classroom: Homework in class, lessons at home. Available: <http://www.learningfirst.org/flipping-classroom-homework-class-lesson-home> [Last accessed 21 February 2017].
- Al-Zahrani, A. M. (2015). From passive to active: The impact of the flipped classroom through social learning platforms on higher education students creative thinking. *British Journal of Educational Technology*, 46(6), 1133-1148.
- Basal, A. (2015). The Implementation of a Flipped Classroom in Foreign Language Teaching. *Turkish Online Journal of Distance Education*, 16(4), 28-37.
- Bishop, J. L. & Verleger, M. A. (2013). The Flipped Classroom: A survey of the Research. *American Society for Engineering Education*, 0(1), 5-6.
- Davis, N. L. (2016). Anatomy of a Flipped Classroom. *Journal of Teaching in Travel and Tourism*, 16(3), 228-232.
- Downs, C. T. & Wilson, A. (2015). Shifting to Active Learning: Assessment of a First-Year Biology Course in South Africa. *International Journal of teaching and Learning in Higher Education*, 27(2), 261-274.
- Duxbury, T., Gainor, M., & Trifts, J. (2016). Increasing Active Learning in Accounting and Finance by Flipping the Classroom. *Journal of the Academy of Business Education*, 1(1), 35-45.
- Early, M. (2016). Flipping the Graduate Qualitative Research Methods Classroom: Did it Lead to Flipped Learning. *International Journal of teaching and Learning in Higher Education*, 28(1), 139-147.
- Enfield, J. (2013). Looking at the Impact of the Flipped Classroom Model of Instruction on Undergraduate Multimedia Students at CSUN. *TechTrends*, 57(6), 14-27.
- Erasmus, B. J., Loedolf, P. vZ., Mda, T. V., & Nel, P. S. (2013). *Managing Training and Development*. 8th ed. New York: Oxford University Press.
- Gillispie, V. (2016). Using the Flipped Classroom to Bridge the Gap to Generation Y. *Ochsner Journal*, 16(1), 32-36.
- Goldsmith, J. (2014). Revisiting the lecture. *Training & Development*, 68(6), 30-33.
- Herreid, F. C. & Schiller, N. A. (2013). Understanding the Flipped Classroom: Part 2. *Journal of College Science Teaching*, 42(5), 62-66.
- Holmes, M. R., Tracy, E.M., Painter, L. L., Oestreich, T., & Park, H. (2015). Moving from Flipcharts to the Flipped Classroom: Using Technology Driven Teaching Methods to Promote Active Learning in Foundation and Advanced Masters Social Work Courses. *Clinical Social Work Journal*, 43(2), 215-224.
- Johnston, N. & Karafotias, T. (2016). Flipping the classroom to meet the diverse learning needs of library and information study (LIS) students. *Journal of Education for Library and Information Science*, 57(3), 226-238.
- Lai, K. & Hong, K. (2015). Technology use and learning characteristics of students in higher education: Do generational differences exist? *British Journal of Educational Technology*, 46(4), 725-738.

- Lee, Y. C., Lau, K., & Yip, V. W. Y. (2016). Blended learning for building student- teachers' capacity to learn and teach science-related interdisciplinary subjects: The case of Hong Kong". *Asian Association of Open Universities Journal*, 11(2), 166-181.
- Li, F., Qi, J., Wang, G., Wang, X. (2014). Traditional classroom vs e-learning in higher education: Difference between student's behavioral engagement. *iJet*, 9(2), 48-51.
- Margolis, A. R., Porter, A. L., & Pitterle, M. E. (2017). Best practices for use of blended learning. *American Journal of Pharmaceutical Education*, 81 (3), 1-8.
- Maurtin-Cairncross, A. (2014). A glimpse of the Y-generation in Higher Education: some implications on teaching and learning environments. *South African Journal of Higher Education*, 28(2), 564-583.
- Milman, N. B. (2012). The Flipped Classroom Strategy. *Journal of Distance Learning*, 9(3), 85-87.
- O'Flaherty, J. & Philips, C. (2015). The use of flipped classrooms in higher education: A scoping review. *The Internet and Higher Education*, 25(1), 85-95.
- Pardo, A., Perez-Sanagustin, M., Parada, H. A. & Leony, D. (2016). Flip with care. Available: <http://www.researchgate.net/publication/232906379>. [Last accessed: 28 February 2017].
- Parslow, G. R. (2014). Commentary Google Glass: A Head-up Display to Facilitate Teaching and Learning. *Biochemistry and Molecular Biology Education*, 42(1), 91-92.
- Park, E. L. & Choi, B. K. (2013). Transformation of classroom spaces: traditional versus active learning classroom in colleges. Available: <http://0-dx.doi.org.innopac.up.ac.za/10.1007/s10734-014-9742-0>. [Last accessed: 1 March 2017].
- Prensky, M. (2001). Digital natives, digital immigrants. *On the Horizon*, 9(5), 1-10.
- Roehl, A., Reddy, S. L., & Shannon, G. J. (2013). To engage Millennial Students through active learning strategies. *Journal of Family and Consumer Sciences*, 105(2), 44-49.
- Sivapalan, S. (2017). Sustainability, blended learning and the undergraduate communication skills classroom: negotiating engineering undergraduates' expectations and perceptions. *On the Horizon*, 25(1), 7-23.
- Warnich, S., Carrell, R., Elbert, N. F., & Hatfield, R. D. (2014). Recruitment and Selection. In: Ainscow, A. and Burt, A. Haman Resource Management in South Africa. 5th ed. United Kingdom: Emily Chandauka.
- Weigel, F. K. & Bonica, M. (2014). An Active Learning Approach to Bloom's Taxonomy: 2 Games, 2 Classrooms, 2 Methods. Available: http://www.cs.amedd.army.mil/amedd_journal.aspx. [Last accessed 1 March 2017].
- Wong, L., Tatnall, A., & Burgess, S. (2014). A framework for investigating blended learning effectiveness. *Education + Training*, 56(2), 233-251.
- Zayapragassarazan, Z. & Kumar, S. (2012). Active learning methods. *NTTCulletin B*, 19(1), 3-5.

PERFORMANCE OF BUSINESS MODEL OF BANKS: IDENTIFICATION AND ANALYSIS

Amani Boussaada and Fatma Siala Guerhazi
University of Tunis El Manar, Tunisia

ABSTRACT

In this study we tried to determine the business model of the Tunisian banks. For this purpose, we used a sample of the 11 banks listed in the Tunisian stock exchange with annual observations over the period 2006-2015. We have identified six indicators that are the most representative of banking activity and whose identification was made thanks to the information available to the public. Our analysis allowed us to identify 3 groups: Model 1: "Diversified commercial banks"; Model 2: "Retail Commercial Banks"; Model 3: Commercial banks with market financing". Then, we determined the best performing business model. According to our results, the most successful business model is the "Diversified commercial banks".

Keywords: Business model, Tunisian banks, cluster analysis, performance, Stochastic Frontier Approach.

INTRODUCTION

Banks are organized according to varied and constantly changing business models that reflect the environment and the economic structures in which they operate. The Tunisian revolution, which broke out in 2011, did not affect all banks in the same way, most banks especially; public banks either lacked or experienced difficulties requiring the intervention of 'State. In response to this difficult situation, public authorities have developed new regulatory requirements which a number of banks have completed with structural reforms. These two aspects are complementary and aim to limit the risk of bankruptcy and contagion, but also to improve performance levels. It is therefore necessary to measure firstly the business model adopted by each Tunisian bank and then determine its level of performance in order to develop a framework that makes risk control and the financing of the economy compatible. Our study is therefore devoted to examining the following key question:

What is the impact of the business model adopted by Tunisian banks on their performance?

Recently the topic of a business model has been often discussed both in the professional and academic publications. The birth of the concept of "business model" (BM) goes back to the 1960s but it has actually emerged since the mid-1990s with the development of Internet services and information technologies. The mutations that were responsible for its development are not only technological, but there are also economic factors such as searching for shareholder value creation and also regulatory factors, especially the deregulation of the banking sector.

Timmers (1998) was one of the first authors to have defined the BM and proposed a typology. His conception of the BM is that it is an architecture of flows of products, services and information, including the description of the different actors involved in the business relationship, their roles and benefits for each as well as the analysis of sources of income. In order to understand how a company fulfills its mission it adds a "marketing model" which is a combination of the BM and the marketing strategy of an actor considered. He proposed a typology of electronic BMs. It distinguishes 11 generic BMs in the Internet economy and ranks them according to their degree of innovation and their level of functional integration.

Linder and Cantrell (2000) suggest a complete vision of the BM. They define a BM as the fundamental logic allowing an organization to create value. They propose a typology of BM based on two dimensions. They obtain a classification of 8 generic BMs. Moreover, they point out that many authors speak of the BM when in fact they refer only to a specific element of a BM. According to them, the components of the BM are: the evaluation model, income model, distribution channel type, business process model, e-commerce relationship, organizational form and value proposition.

The academic literature provides several definitions of a business model: “A Business Model describes the rational of how an organization creates, delivers and captures value” (A. Osterwalder and al, 2010); “Business model as representation of a set of components utilized to outperform the competition and to achieve optimal profit in a financial market where a similar product strategy used” (M. Tomkus, 2014) and “Business models are the means and the methods used to operate, to generate profits and to grow. They result from multiple intertwined elements that reveal the way a company organizes its core activities to achieve its main objectives” (European Banking Authority, 2013).

OVERVIEW OF TUNISIAN BANKING SYSTEM

The Tunisian banking sector has 29 establishments, including 11 banks listed on the stock exchange. Unlike neighboring and western markets, concentrated around a few large financial institutions, the Tunisian banking sector is differentiated by its "atomicity". Between public banks, universal private banks, specialized banks, investment banks, a better concentration of the banking market would now be better for the stability of the financial system. With a market capitalization of 8 billion dinars, the banking sector is the first market force, accounting for 41% of the total capitalization. Today, six years after the revolution, it became urgent to make the balance sheet of the situation in order to allow Tunisian banks to play their full role.

Indeed, the first victim of the post-revolution crisis, the Tunisian banking sector suffered from an economic system in difficulty: lack of liquidity, deterioration of the business environment, increase in unpaid loans, etc. At the same time, the CBT¹ revealed significant shortfalls in capitalization and organization at some banks. Over 1,000 MTD of additional provisions have been booked over the past 4 years, and four banks have launched a recapitalization plan.

RESEARCH METHODOLOGY

In line with the objective of the study of identifying different BM and determining the most performing model the analysis proceeds in two phases. In the first phase, several instruments were used as a basis for creating business models using cluster analysis tools. In the second phase, business models were evaluated and compared based on their performance by the SFA method.

Identification of the business models of banks using the statistical clusters analysis

A "data clustering" analysis is defined as the collection of populations studied according to selected factors. The formation of a group of factors (cluster) is based on shared similarities among members of the population. In this particular case, we intend to assign banks (population) into clusters based on similar observational values observed

¹ Central Bank of Tunisia

in a scale of (variable) factors. The process of cluster formation ensures cluster dissimilarity, because each cluster is distinguished by different characteristics. In this study, Ward's method was chosen as the most appropriate for the data collected. This method is based on the analysis of variance to evaluate the distances between the clusters. Essentially, the Ward method forms clusters by minimizing the sum of the squares of two clusters from the previous sequence generation. The detailed description of this method is explained by J. H. Ward himself in his article on the hierarchical grouping (Ward, 1963). In order to determine the optimal number of clusters, we used the pseudo-F index. The procedure involved K-means data clustered for a specified number of clusters. Each cluster combination solution provides ANOVA tables with pooled F variables (VRCs) that, when summed, provide a VRC value for a particular number of group solution.

In our research work, we are fully established the work of Ayadi and al. (2011, 2014a, 2015) in order to determine the business model of Tunisian banks. Six instruments have been identified which constitute the activity determined from an asset and liability stand point, were used to form the clusters. These were: Customer Deposits to total Assets (CDA); Customer Loans to total Assets (CLA); Interbank liabilities to total Assets (ILA); Loans to Bank to total Assets (LBA); Commercial securities portfolio and investment portfolio to total assets (PCIA); Equity to Total Assets (ETA).

Estimation of a stochastic frontier translog cost function

The question to be answered concerns the best combination of inputs that can produce an optimal combination of outputs while minimising production costs. Given the multiplicity of functions of a bank, we consider the translog function to be the most appropriate compared with other functional forms because it takes into account multiple complementary links between the explanatory factors and does not impose any restriction on the form of the cost function. We specify this function in its standard form as follows:

$$\ln CT_i = \ln C(Y_i, P_i, \beta) + \varepsilon_i \text{ With } \varepsilon_i = U_i + V_i ; \text{ for each bank } i = 1, \dots, N.$$

Where CT_i is the total cost of the i^{th} bank,

Y_i is the vector of outputs of the i^{th} bank; P_i is the vector of input prices of the i^{th} bank,

β is the vector of parameters.

U_i is a measure of technical inefficiency and is distributed only one side of the border,

V_i is the error term (random shock). These two terms are independent.

Outputs	Y1: Total credits, which includes credits to customers (portfolio discount accounts receivable of clients + Credits on special resources + Other customer loans) and interbank loans (loans to banks and specialised agencies + cash, BCT, certificates of deposit and commercial paper).
	Y2: The securities portfolio, which represents the commercial securities portfolio and the investment portfolio. The securities portfolio, which represents the commercial securities portfolio and the investment portfolio.
The prices of production factors	The price of labor (wL): Personnel expenses / Number of employees.
	The price of financial capital (wD): Interest Expense / Total borrowings.
	The price of physical capital (wk): amortization and impairment of assets / Fixed assets.

We selected a sample of 11 Tunisian banks listed on the stock exchange (ATB, BNA, Attijari Bank, BT, AB, BIAT, STB, UBCI, UIB, BH and BTE)² over the period 2006-2015.

² ATB: Arab Tunisian bank; BNA: Agricultural National Bank; Attijari Bank; BT: Banque de Tunisie; AB: Amen Bank; BIAT: banque international arabe de Tunisie; STB: Société Tunisienne de banque; UBCI: Union Bancaire pour le commerce et l'industrie, UIB: International banking union; BH: Banque de l'Habitat ; BTE: Banque de Tunisie et des Emirates.

RESULTS

Identification of business models of Tunisian banks

The following table summarizes the calculated pseudo-F indices: The solution proposed by the highest pseudo-F index (73, 88) indicates a distinct optimal solution to three groups.

Number of Clusters	Pseudo-F index	Number of Clusters	Pseudo-F index
2	37.05	7	58.27
3	73.88	8	54.35
4	62.14	9	51.17
5	56.59	10	57.09
6	37.05	author's calculation	

Clusters	ILA	LBA	CDA	PCIA	ETA	CLA
Model 1	13%	5%	81%	17%	8%	61%
Model 2	5%	4%	72%	9%	8%	78%
Model 3	14%	9%	36%	8%	24%	72%
Total	8%	5%	71%	11%	10%	73%

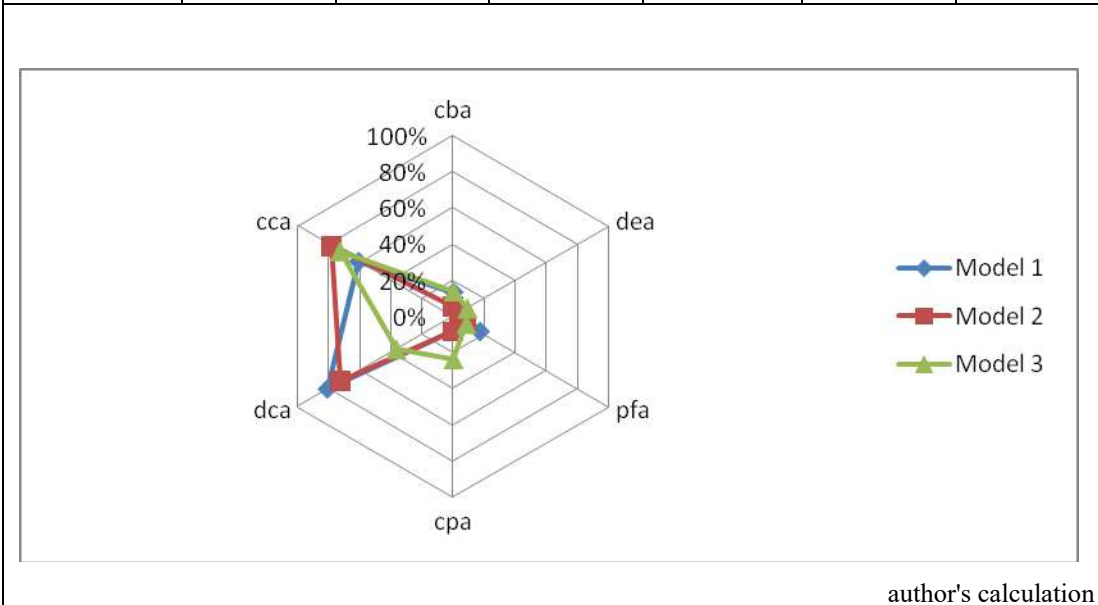

Model 1: "Diversified commercial banks": Banks are, on average, the most active in the traditional intermediation of deposit loans. The number of banks that belong to this group amounts to only 4 namely ATB, Attijari Bank (except for the two years 2011 and 2012), BIAT, and UBCI (2009).

Customer deposits represent 81%, the highest average of all BM identified for deposits and customer acquisitions compared to total assets, while customer loans represent 61% of total assets. The remaining exposures, the creations on the banking institutions and Commercial securities portfolio and investment portfolio, are respectively 13% and 17% of the active total.

Model 2: "Retail Commercial Banks": This is the most common business model among the observations in this study. In total, 8 banks belong to this group, which represents about 88% of the banks sampled. A notable identifier of this model is the highest average of all models identified for customer receivables relative to the active total (CCA), corresponding to 78%.

The banks belonging to this group are: BNA, BT, AB, STB, UIB, BH, Attijari Bank (2011 and 2012) and UBCI (2006-2008; 2010-2015).

Model 3: "Commercial banks with market financing": It is the smallest group, it consists of two banks BTE and BT (2010). Like other groups, a high ratio of customer receivables 72% of total assets. Another distinctive characteristic of this model is the highest average of the 3 models for interbank liabilities on total assets (CBA), with 14%. This group shows the greatest dependence on interbank borrowing, implying that almost 14% of their average total financing comes from a more expensive source than other commercial banks. In addition, it should be noted that banks belonging to this group have the highest rate of equity 24% of total assets. It should be noted that BTE is the biggest increase in credits in the market, with an increase of 22.6% to 120 Mdt in 2015.

Performance of banking business models

Bank	Means	Bank	Means
Attijari Bank	93.83%	2. STB	92.21%
3. BIAT	91.02%	4. UIB	90.56%
5. UBCI	89.40%	6. ATB	88.85%
7. BTE	88.63%	8. BH	84.81%
9. AB	83.53%	10. BNA	82.76%
11. BT	74.72%		author's calculation

The results obtained from panel data suggest that the banks in our sample, regardless of big or small size (in terms of total assets), report relatively similar degrees of effectiveness.

Over the period studied, the banks with the highest efficiency were: Attijari Bank (93.83%), BIAT (91.02%) followed by UBCI (89.4%), BTE (88.63%). The results are implied, banks are able to increase their efficiency by 6.17% (for Attijari Bank); 8.98% (for BIAT); 10.6% (for the UBCI) and 11.37% (for the BTE) while maintaining the same level of activity.

Nevertheless, observation of the average efficiency scores shows that two major banks: BH and BNA have the lowest average efficiency levels. This paradoxical result could be explained as follows: the large Tunisian commercial banks are more efficient than the small banks. However, according to Karray and Chichti (2006), there is a level of operations for large banks beyond which returns to scale become diminishing. In addition, these banks (BH and BNA) have accumulated high amounts of unpaid credits in past years that have a negative impact on their profitability and thus lead to low levels of efficiency.

According to our results, the most successful business model is the "Diversified commercial banks". The "Retail Commercial Banks" ranks second. It should also be noted that during the period studied transitions between the first two groups were carried out. While the third model remained relatively stable over time as bankers could draw on interbank markets and debt.

CONCLUSION

In this study we have two objectives, first to identify the Business model adopted by each Tunisian bank. And secondly, determine the best performing BM. Our study includes 11 Tunisian banks listed in stock exchange over a 10-year period; namely the period (2006–2015).

Previous studies tried to define the concept of BM, but recent studies and ours are more interested in understanding what makes the specificity of BM, in order explain the Tunisian banks' performance. The study proved to be technically capable of identifying business models with the use of 6 derived identifiers for the sampled banks: Customer Deposits to total Assets (CDA); Customer Loans to total Assets (CLA); Interbank liabilities to total Assets (ILA); Loans to Bank to total Assets (LBA); Commercial securities portfolio and investment portfolio to total assets (PCIA); Equity to Total Assets (ETA), and provided analytical insight in the constructed business models and banks within the observation period. Nevertheless, the results of the study are highly dependent on multiple factors that defined the processes and methodology of this study, thus, the findings of the study should be evaluated with care.

In addition, this study explained the differences in efficiency between the Tunisian commercial banks. Our research has identified the decision variables on which Tunisian bank managers can act to increase their efficiency levels. Two conclusions could be drawn:

- Improving the efficiency of Tunisian commercial banks requires better control over lending activity, which appears to be a source of revenue for Tunisian banks. This implies the adoption of new methods of assessment and risk management by Tunisian banks as recommended by the new Bale III banking regulation.
- It also requires an increase in the size of some small banks and a reduction in the size of large banks to optimum levels.

Further research should consider the limitations of this study. It is the first attempt to empirically examine Tunisian bank business models for identification. Deeper empirical analysis of each bank BM component would be very useful in the future. Besides, this study does not include environmental variables such as regulatory changes or economic conditions, having demonstrated in a previous work, in particular Dietsch and Vivas (2000), a significant effect on efficiency levels.

Moreover, recommendations require further deeper analysis of the role of banks and local governments in financing SMEs. Transparency and public disclosure practices remain an important concern. Disclosure practices of banks, which are of the utmost importance to comparing banks, were incomparable and incomplete. Many researchers have already raised this problem; however, the situation has not changed significantly.

Banking business models still remain a major concern. Banks face major challenges to adapt to the new economic, financial and regulatory realities. Several factors affect their changes: new regulatory measures, market pressures or the search for more sustainable profits, enhance further pressures on banks.

REFERENCES

Ayadi, R. & W.P. de Groen, (2014a), "Banking Business Models Monitor 2014: Europe", Montreal, Joint Centre for European Policy Studies (CEPS) and International Observatory on Financial Service Cooperatives (IOFSC) publication (<http://www.ceps.eu/book/banking-business-modelsmonitor-2014-europe>).

Ayadi, R., De Groen W.P, Sassi I, Mathlouthi W, Rey H & Aubry O, (2015), "Banking business models monitor", Centre for European Policy Studies (CEPS).

- Ayadi, R., E. Arbak & W.P. de Groen, (2011), “Business Models in European Banking: A pre-and post-crisis screening”, Centre for European Policy Studies (CEPS), Brussels.
- Bannour B. & Labidi M. (2013), “Efficiency of the Tunisian Trade Banks: Study by the Stochastic Frontier Approach”. *PANOECONOMICUS*, 1, 103-132.
- Dietsch M. & Lozano Vivas A., (2000), “How the environment determines banking efficiency: A comparison between French and Spanish industries”, *Journal of banking and finance*, Vol 24, 985-1004.
- European Banking Authority. (2013), *Banks’ business models: Definition, evolution and challenges*. London.
- Karray C. & Chichti J. (2006), « *Efficiency, productivité et progrès technologique en fonction de la taille de la firme bancaire : preuves empiriques sur les banques commerciales en Tunisie* », *Euro-mediterranean Economics and Finance Review*, Vol 1, N°2.
- Linder, J., & Cantrell, S. (2001), *changing business models: Surveying the landscape*, Accenture Institute for Strategic Change.
- Osterwalder A. and Y. Pigneur. (2010), *Business Model Generation*. Wiley – La German.
- Timmers, P. (1998), *Business models for electronic markets*, *Electronic Markets*, 8(2), 3-8.
- Tomkus M. (2014). *Identifying Business Models of Banks: Analysis of Biggest Banks from Europe and United States of America*. Aarhus University, Business and Social Sciences.
- Ward, J.H. (1963), “Hierarchical grouping to optimize objective function”, *Journal of the American Statistical Association*, Vol. 58, No. 301, 236-244.
- Zott, C., & Amit, R. (2010), *designing your future business model: An activity system perspective*, *Long Range Planning*, 43, 216-226.

GOOD GOVERNANCE IN LOCAL GOVERNMENT: A SOUTH AFRICAN PERSPECTIVE

Maleka Mogotsi Caiphus
Tshwane University of Technology, South Africa

ABSTRACT

The ideal of good governance is to ensure that there could be a transition in manner which government provides its services. This transition is intended that government could strive to get the basics rights thus ensuring effectiveness and efficiency. The local government turn-around strategy in South Africa indicated the overarching goal or vision thus being a responsive, accountable, effective and efficient local government. Furthermore, the Constitutional ideals of South Africa advocate for high professional ethics and norms to be taken in consideration. This paper provides an understanding of the concept good governance within a domain of local government. A qualitative research approach is employed in this research paper with an attempt to explore good governance in local government and how it could be employed to enhance adherence to the Constitutional obligations. Furthermore, this paper provides conclusion and recommendations emanating from literature review and observation.

Keywords: governance, local government.

INTRODUCTION

The fundamental perception about good governance could mainly be towards ensuring that government optimises the manner in which it conducts its business. This could largely be informed of principles of good governance that should be adhered and respected in realising the essence of good governance. It is against this backdrop that an ideal of good governance derives from the need of ensuring effectiveness, efficiency, accountability and respect of the rule of law.

The notion of good governance in local government entails fostering transparency and accountability, thus ensuring that citizens could hold government accountable. In this regard, these constitutional ideals within the context of South African government seek to prohibit maladministration and corruption which may constitute bad governance. This paper provides us with an understanding towards governance and good governance in local government with reference to the Republic of South Africa.

Governance and Good governance

Maserumule, (2011:264) is of the view that governance is a conceptual presentiment of good governance. Without the concept governance, good governance would not have been part of the conceptual scheme in the parlance of the contemporary development discourse which shapes thoughts and perceptions in the description of the paradigm of thinking in state formation or re-invention. But governance does not owe its conceptual existence to good governance. The conception of governance without good governance is logically possible. However, the same cannot be said about good governance without governance. For, good is an adjective qualifying the noun governance. Good governance owes its conceptual existence to governance.

With this notion in mind, it would be imperative that a clarification on the concept governance be unpacked before analysing good governance. Louw, (2012:94) postulate that in its original sense the word governance means 'steering', or simply, navigating, giving direction. As a result, governance has become a leading theme in policy development discourse and social science scholarship. Although the phenomenon is well established in South Africa, and despite the popularity of the phenomenon among both theoreticians and practitioners, there is still a lack of conceptual consensus. It has multiple meanings and there is a good deal of uncertainty in its different usages.

In the light of the above, the concept of governance may refer to the manner in which government executes its public policy to ensure that the set objectives could be attained. It entails actions undertaken to ensure that desired results could be achievable. On the other hand, Kettani, and Moulin,(2014:75) confirms a view of IDRC (2005) concerning an evolution in the concept of good governance. First appearing in the twentieth century, the notion of good governance began in the discussions of business analysts and economists who were highlighting the structures and strategies of corporate management which succeed in increasing productivity and profits.

De Vries, (2011:70) is of the view that the term good governance was a spin-off from the Washington consensus during which the World Bank and IMF agreed that 'good governance' was a prerequisite for the granting of loans and subsidies to poor, developing countries. Such countries would only be granted loans if they guaranteed good governance - in other words, a government and bureaucracy without nepotism, corruption or maladministration. World Bank (2006) in Kettani, and Moulin, (2014: 76) suggest that good governance (or the good use of governmental power) is "epitomized by predictable, open and enlightened policy making; a bureaucracy imbued with a professional ethos; an executive arm of government accountable for its actions; and a strong civil society participating in public affairs, and all behaving under the rule of law".

Concepts related to good governance

For an in-depth understanding of good governance, it is imperative that key concepts that relate to good governance be unpacked. Following is the elucidation on the concepts:

Democracy

Democracy is a word that has come to mean very different things to different people. In origin it is, of course, Greek, a composite of *demos* and *kratos*. Since *demos* can be translated as "the people" and *kratos* as "power," democracy has a root meaning of "the power of the people." In modernity, democracy is often construed as being concerned, in the first instance, with a voting rule for determining the will of the majority. The power of the people is thus the authority to decide matters by majority rule (Ober, 2008:3).

Public participation

Public participation can be broadly defined as a process where all men and women are given an opportunity to have a voice in decision-making, either directly or through legitimate, intermediate institutions that represent their aspirations. Such broad participation is entrenched in freedom of association and speech, as well as capacities to participate meaningfully. In any democratic country, such as South Africa, participation by both men and women is a cornerstone of good governance (Mofolo, 2016: 232 in Graham, Amos & Plumpre, in Qorbani & Feizi, 2014:2; Mzimakwe, 2010:505).

Accountability

Fombad, (2014:73) suggest that accountability is a complex, elusive, abstract, multifaceted and contested issue that can be approached in different ways, depending on the role, institutional context, era and political perspective.

Accountability has traditionally been taken to mean answerability for one's action or behaviour, which came to mean that the actions of public officials had to be justified, their reasons explained and their deeds and misdeeds accounted before the court of public opinion (Diale, Maserumule and Mello, 2007:641 in Dwivedi and Jabbara, 1988).

Transparency

Armstrong, (2005:1) suggest that transparency refers to unfettered access by the public to timely and reliable information on decisions and performance in the public sector. In this regard, transparency must be fostered by providing the public with timely, accessible and accurate information. According to Stirton and Lodge, (2001:476) transparency can be understood to serve two separate but related functions. The first is to ensure that public service providers respect both the positive and the negative rights of individuals. The second purpose relates more directly to democratic theory, which values participation by individuals in the decisions which affect them.

Legal framework enhancing good governance in local government

Within the context of South African government, various pieces of legislation have been enacted as a mechanism to measure, promote, encourage and enhance an effective, efficient and economical system of governance in all spheres. With respect to the local sphere of government the following will receive scrutiny:

The Constitution of the Republic of South Africa, 1996

The Constitution, 1996 sets out the basic values and principles governing public administration and which should be adhered to by all those who practise public administration in the Republic. Chapter 10 of the Constitution of the Republic of South Africa, 1996 clearly stipulate that Public administration must be governed by the democratic values and principles enshrined in the Constitution, including the following principles:

- (a) A high standard of professional ethics must be promoted and maintained.
- (b) Efficient, economic and effective use of resources must be promoted.
- (c) Public administration must be development-oriented.
- (d) Services must be provided impartially, fairly, equitably and without bias (Constitution of the Republic of South Africa, 1996).

These basic values and principles governing public administration apply to spheres of government. Thus it may be imperative that local government employees observe and adhere to the aforementioned principles in the quest of good governance.

Promotion of Access to Information Act, Act 2 of 2000

This purpose of this Act is mainly to foster a culture of transparency and accountability in public and private bodies by giving effect to the right to access information, and to actively promote a society in which people of South Africa have effective access to information to enable them to fully exercise and protect all their rights.

It is important therefore to note that in South Africa, the importance of information is underscored in the Constitution of the Republic of South Africa, 1996. In this regard, section 32(1) (a) indicate that everyone has the right of access to any information that is held by the state and any information that is held by another person and that is required for the exercise or protection of any rights.

Local government: Municipal finance management Act, Act 56 of 2003

The local government municipal finance management Act, Act 56 of 2003 is arguably one of the most pieces of legislation promoting openness, transparency and accountability in local government thus an important cornerstone in ensuring good governance. The objective of this Act is to secure sound and sustainable management of the fiscal and financial affairs of municipalities and municipal entities by establishing norms and standards and other requirements for ensuring transparency, accountability and appropriate lines of responsibility in the fiscal and financial affairs of municipalities and municipal entities;

Local Government: Municipal Systems Act, Act 32 of 2000

The Local Government Municipal Systems Act provides for the core principles, mechanisms and processes that are necessary to enable municipalities to move progressively towards the social and economic upliftment of local communities and to ensure universal access to essential services that are affordable to all. It also provides for the manner in which municipal powers and functions are exercised and performed. It further provides for the building of local government into an efficient development agency for the overall social and economic upliftment of communities. To achieve these objectives, the Act sets out a code of conduct for councillors and municipal staff members. Following is the elucidation of the code of conduct for councillors.

Characteristics of good governance

The UNDP managed to establish eight general characteristics of good governance. These principles include participatory, consensus oriented, accountable, transparent, responsive, effective and efficient, equitable and inclusive, and follows the rule of law. The ideal of these principles would be assuring that corruption is minimised, the views of

minorities are taken into account and that the voices of the most vulnerable in society are heard during decision making (Kettani, and Moulin, 2014: 76). Following is the elucidation of the principles:

- (a) Participation: participation by a diverse demographic of society's constituents is a key cornerstone of good governance. Participation can be either direct or through legitimate intermediate institutions or representatives
- (b) Rule of law: good governance requires fair legal frameworks that are enforced impartially. It also requires the full protection of human rights, particularly those of minorities. Impartial enforcement of laws requires an independent judiciary and an impartial and incorruptible police force.
- (c) Transparency: transparency means that the decisions made and their enforcement is done in a manner that follows rules and regulations.
- (d) Responsiveness: good governance requires institutions and processes to serve stakeholders within a reasonable timeframe.
- (e) Consensus oriented: there are several actors and many viewpoints in any given society. Good governance requires the mediation of different interests in a society to reach a broad consensus on what is in the best interests of the whole community and how this can be achieved.
- (f) Accountability: accountability is a key requirement of good governance. Not only governmental institutions, but also the private sector and civil society organizations must be accountable to the public and to their institutional stakeholders (Kettani, and Moulin, 2014: 77).

These aforementioned principles of good governance seek to promote government which is ethical and responsive to the needs of the people.

STATE OF LOCAL GOVERNMENT IN A DEMOCRATIC SOUTH AFRICA

Although there has been significant strides made in local government in optimising human needs, there have been numerous reports detailing the problems facing local government as a sphere closer to the people. Although the problems are vast, some of them include the following:

The main challenge has been unevenness in capacity that leads to uneven performance in Local, Provincial and National government. This is caused by a complex set of factors, including the following:

- Tensions in the political-administrative interface;
- Instability of the administrative leadership;
- Skills deficits;
- The erosion of accountability and authority; and
- Poor organisational design and low staff morale (National Development Plan-2030, 2013:408).

In the light of the above, the South African National Development Plan- 2030 certainly admits that political interference and political appointments have caused 'turbulence that has undermined the morale of public servants and citizens' confidence in the State'. As a blue print towards 2030, reforms ought to be undertaken thus a remedial intervention.

It may also be noted that a lack of capacity or skills in local government affects the way local municipalities are run and therefore their ability to deliver on their mandate. In this regard, vacancies in key positions and key officials without the minimum competencies and skills continued to make it difficult to produce credible financial statements and performance reports.

In relation to a lack of accountability, perhaps a lack of consequences could be one of the reasons why poor performance is allowed to continue. Within this context, lack of accountability and lapses in leadership could be some of the causes of local governance failure.

RESEARCH PHILOSOPHY

All research is based on assumptions about how the world is perceived and how one could best understand the world (Trochim, 2001:14). Easterby-Smith, Thorpe and Lowe, (2002: 27) suggest that if one fails to think on philosophical issues in his/her research it can seriously affect the quality of research itself.

The researcher in this regard was inspired by the interpretivism research philosophy which advocates that it is necessary for the researcher to understand differences between humans in our role as social actors. This emphasises the difference between conducting research among people rather than objects such as trucks and computers (Saunders et. Al 2009:116). In this regard, Göran, (2012:1) confirms a view of Trauth (2001b: 7) that interpretivism is the lens most frequently influencing the choice of qualitative methods.

RESEARCH METHODOLOGY

Qualitative research, broadly defined, means any kind of research that produces findings not arrived at by means of statistical procedures or other means of quantification (Strauss and Corbin, 1990: 17). The qualitative methodology orients social and behavioural scientist primarily working within the constructivist paradigm and principally interested in narrative data and analyses (Teddlie and Tashakkori, 2009:4).

Qualitative research is concerned with developing explanations of social phenomena. That is to say, it aims to help us to understand the social world in which we live and why things are the way they are. It is concerned with the social aspects of our world and seeks to answer questions about:

- Why people behave the way they do;
- How opinions and attitudes are formed;
- How people are affected by the events that go on around them; and
- How and why cultures and practices have developed in the way they have Hancock, Ockleford, and Windridge, (2009:7).

Brynard, Hanekom and Brynard, (2014:8) confirms a view of Mouton, (1983:128) that qualitative methodology is associated with analytical research, and its purpose is to arrive at a universal statement. In the light of the above, the researcher guided by the interpretivist philosophy, employed a qualitative research methodology in arriving to the following measures that may be undertaken in South African local government with an ideal of enhancing good governance.

MEASURES THAT COULD BE UNDERTAKEN IN OPTIMISING GOOD GOVERNANCE IN LOCAL GOVERNMENT

- The three spheres of government are distinctive, interrelated and interdependent. It is pivotal that the working relationship of these spheres be improved to fast track the provision of services.
- Capacity and competency of human capital should also be improved. This could assist in mitigating challenges of fruitless, wasteful and irregular expenditure in local governance.
- Accountability should be reinforced in local government. Members of the public should be able to hold their electorate accountable for their actions in the provision of services.
- A clear political and administrative interface should be promoted. This would ensure that both political and administrative official understand clearly their roles and what is expected from them.

CONCLUSION

It could be noted that within the context of South African local government, legislative aspects influencing good governance have been established. However contrary to theory, local government is still faced with numerous challenges which may equate bad governance. For the National Development Plan- 2030 vision to be achievable, a lot of reforms should be undertaken especially on the implementation phase to ensure that desired results are achieved

in line with what policy formulation. Local government as the sphere closer to the people, is expected to be efficient, effective and responsive to the needs of the community. Contrary poor service delivery and violent public service delivery protest could be observed amid 23 years of South Africa's democracy.

REFERENCES

- Armstrong, E., 2005. *Integrity, transparency and accountability in public administration: Recent trends, regional and international developments and emerging issues*. United Nations, Department of Economic and Social Affairs, pp.1-10.
- Brynard, D. J., Hanekom, S. X., and Brynard, P. A. 2014. *Introduction to research*. 3rd ED. Van Schaik: Pretoria.
- De Vries, J. 2011. *Governance and Public Leadership*. In Bjorkman, J.W., R. van Eijbergen.
- Diale, A. J., Maserumule M.H., and Mello D. M. 2007. Public sector administrative reforms and accountability: "A marriage of inconvenience". *Journal of Public Administration*, Vol 42 (7):638-649.
- Easterby-Smith, M., R. Thorpe, and A. Lowe. 2002. *Management Research an Introduction*. Thousand Oaks: Sage Publications.
- Fombad, M.C. 2014. Enhancing accountability in public-private partnerships in South Africa. *Southern African Business Review Volume 18 (3):66-92*.
- Göran, G. 2012. *Pragmatism vs interpretivism in qualitative information systems research*,
- Hancock, B., Ockleford, E., and Windridge, K. 2009. *An Introduction to Qualitative Research*. The NIHR RDS EM / YH.
- Kettani, D. and Moulin B. 2014. *E-Government for Good Governance in Developing Countries: Empirical Evidence From the EFez Project*. London : Anthem Press.
- Louw, V.N. 2012. From public administration to governance: science or ideology? *Journal of Public administration*, 47(1):88-101.
- Maserumule, M. H. 2011. *Good governance in the new partnership for Africa's development (NEPAD): A Public Administration perspective*. Published DLit. Phil. University of South Africa.
- Mofolo, M. A. 2016. Intergovernmental Relations System for Public Participation in the Local Sphere of Government. *Journal of Public Administration*, Volume 51 (2): 230-245
- Ober, J. 2008. The Original Meaning of "Democracy": Capacity to Do Things, not Majority Rule. *Constellations* Volume 15, No (1):3-9.
- South Africa Republic. The Constitution of the Republic of South Africa, 1996. Pretoria: Government Printers.
- South Africa, Republic. 2000. Local Government Municipal Systems Act, Act 32 of 2000. Government Printers: Pretoria.
- South Africa, Republic. 2000. Promotion of Access to Information Act, Act 2 of 2000. Government Printers: Pretoria.
- South Africa, Republic. 2003. Local government: Municipal finance management Act, Act 56 of 2003. Government Printers: Pretoria.
- South Africa, Republic. 2013. National Development- Plan 2030. Government Printers: Pretoria.

Stirton, L. and Lodge, M., 2001. Transparency mechanisms: Building publicness into public services. *Journal of Law and Society*, 28(4): 471- 489.

Teddlie, C., and Tashakkori, A. 2009. *Foundations of mixed methods research: integrating quantitative and qualitative approaches in the social and behavioural sciences*. Sage Publications, Inc. London.

Trochim, W. M. K. 2001. *The research methods knowledge base*, Atomic Dog Publishing: Cincinnati.

EFFECTS OF EMOTIONS EXPRESSION OF ONLINE REVIEWER ON THE PERCEIVED HELPFULNESS OF REVIEW READERS: FROM AN AGGREGATIVE PERSPECTIVE OF THEORY

Mei-Ju Chen

Chienkuo Technology University, Taiwan, R. O. C.

ABSTRACT

The study aims to explore the effect of specific emotions embedded in online review on reader's perceived helpfulness. In a laboratory experiment, 196 undergraduate business students at a major university are recruited to read and evaluated restaurant service reviews. Results show that (1) reviews with negative emotions appear to be perceived as having been invested with more effort than those with positive emotions. (2) In the negative emotion, reviews containing content indicative of anxiety were considered more helpful than those containing content indicative of anger. (3) In the positive emotion, reviews containing content indicative of surprise were considered more helpful than those containing content indicative of pride. (4) The perceived cognitive effort has a positive impact on perceived helpfulness. Implication for research and practice are discussed.

Keywords: Online Word of Mouth, Emotions Expressions, Online Product Reviewers, Review Helpfulness

INTRODUCTION

The proliferation of the Internet has dramatically enhanced consumers' ability to share information about products and services with other consumers. Customers usually choose to spread the word-of-mouth (WOM) by writing a product/service review on a Website. Website owners have commonly used review "helpfulness" as the primary way of measuring how readers evaluate an online review. The importance of these reviews to consumers is reflected in a 2016 survey by the BrightLocal, in which 87% of people trust online reviews as much as a personal recommendation. It is estimated that this simple question "Was this review helpful to you" brings in about 2.7 billion additional revenue to Amazon.com. Electronic word of mouth (eWOM) thus emerged to play an important role in the consumer decision-making process. Thereafter, academic researchers have regarded readers' perceived helpfulness as an important referential indicator for online product review studies (Wan and Nakayama, 2014). In general, an online product review can be divided into two parts: (1) the content of the review itself, and (2) the quantified aspects that represent the overall value of the review (Wu et al., 2011). However, past research mostly focused on aspects that are easier to observe: the quantitative aspects of the reviews, like the length of the reviews, or the number of reviews a product has received, to examine readers' perceived helpfulness (Forman et al., 2008; Mudambi and Schuff, 2010; Pan and Zhang, 2011; Ghose and Ipeiritis, 2011; Schlosser, 2011).

Researcher indicated that the sender's transmission of eWOM has emotional antecedents. Recently, some researchers have taken a content-based approach to explore the connotations of the reviews and the influence of reviewers' emotions or emotional expression on readers (Cao et al., 2011; Kim and Gupta, 2012; Baek et al., 2013; Yin et al., 2014a). It can, thus, be seen that both objective, quantified statistics and subjective, emotional expression can affect readers' perceived helpfulness of product reviews. However, emotions are often conceptualized as general dimensions, like positive and negative affect. More specifically, the valence-based (positive vs. negative) emotion fail to illustrate whether different emotions of the same valence differentially influence judgements and choice. For example, a failure in a product/service can elicit the emotions of anger or

fear. Both angry and fear people feel something wrong has been done to them, angry person becomes inactive and withdrawn, the angry person becomes more energized to fight against the cause of anger. Therefore, it is important to take into account differences across emotions of the same valence. Therefore, this study intends to achieve the follow purpose: Explore how the effect of specific emotions embedded in online review on reader's perceived helpfulness.

RELATED CONCEPTUAL AND THEORETICAL BASED

eWOM: Helpfulness of Online Reviews

Word of mouth (WOM) refers to the free discussion and communication among consumers regarding market and consumption-related matters, which are characterized as non-commercial, two-way-communication-based, experience-oriented, and timely (Silverman, 1997). In an online context, the majority of websites offer readers tools to measure the quality of the review content. Generally, a common practice involves a polar question about the reviews, asking, "Is this review helpful to you?" Readers are expected to choose between only two answers: "yes" and "no." The website will then compile all the responses and present them in a statistical manner. For example, if 20 out of 100 people think this review was helpful, then the helpfulness of this review can be considered to be 20% (Cao et al., 2011), which means the review has generated a certain amount of eWOM. Therefore, the helpfulness of an online product review refers to the peer assessment and the helpfulness of a given review in relation to consumers' decision-making processes (Mudambi and Schuff, 2010). Therefore, a product review with high information diagnosticity usually implies that the reviewer is able to clearly communicate product-related information, which is helpful for the information seekers in terms of measuring the quality and utility of the product (Mudambi and Schuff, 2010).

Cognitive Appraisal Theory

The cognitive appraisal of emotions refers to individuals' cognitive ability to identify subtle differences that can distinguish between more specific and precise emotional states implied in positive and negative emotions (Tiedens and Linton, 2001). This theory asserts that individuals' emotional response towards a specific event is the result of interpreting (appraising) the event in a specific context (Frijda, 1986; Roseman, 1984). Therefore, Lerner et al. (2014) proposed six cognitive-appraisal dimensions, including certainty, pleasantness, attentional activity, anticipated effort, individual control, and others' responsibility for negative events, to distinguish the subtle differences of the various emotional states. Here, certainty refers to the extent to which a future event or circumstance is considered predictable or comprehensible by an individual. Pleasantness refers to whether the given event or circumstance can make the individual feel pleasure. Attentional activity refers to the degree to which the given event or circumstance draws the individual's attention. Anticipated effort refers to the amount of effort that the individual is expected to be physically or mentally involved in, for the given event or circumstance. Individual control refers to whether the individual has control over the given event or circumstance. Others' responsibility refers to the degree to which the given event or circumstance is caused by others. Therefore, when facing a specific environment or event, individuals' responses are manifested through emotional expression after the six dimensions of cognitive appraisal are assessed.

Heuristic-Systemic Model

The Heuristic-Systemic Model (HSM) (Chaiken, 1987) help researchers understand how various consumption emotions triggered by specific circumstances/products influence subsequent cognitive thinking processes (Tiedens and Linton, 2001). According to HSM, when individuals process information, they tend to adopt one of two strategies. The first strategy is heuristic processing, which refers to using a small amount of existing information or a single clue for judgment, rather than investing a large amount of cognitive effort. The second strategy is systematic processing, which refers to the consideration of all decision-related information fragments, covering a comprehensive measurement of target and context-related messages, and in-depth thinking, prior to making decisions. Therefore, applying systematic processing requires a higher degree of motivation and ability to be put into cognitive processing. In addition, according to HSM, since the cognitive effort required by heuristic processing is lower than systematic processing, individuals are more inclined to apply heuristic

processing, and only use systematic processing in specific situations. Specifically, individuals' decisions to apply a specific processing strategy are determined by the continuum of judgmental confidence towards the target and situation (Solloway, 2010). Certainty and individual control are the two dimensions based on cognitive appraisal that determine individuals' adoption of processing strategies.

HYPOTHESIS DEVELOPMENT AND RESEARCH MODEL

Drawing on the cognitive appraisal theory of emotion, the valence-based emotions was separated into more specific concepts which including angry, fear, surprise and pride. Second, through heuristic-systemic model, the author infers the context of information processing varying with the specific emotion. Therefore, the hypotheses 1, 2 and 3 were proposed to understand how distinct emotions of reviewer embedded in online review affect receiver's perceived cognitive effort. Finally, we explore how the reader perceptions of the cognitive effort expended by the reviewer affect perceptions of review helpfulness. Therefore, hypothesis 4 was proposed. The entire research model is illustrated in Figure 1.

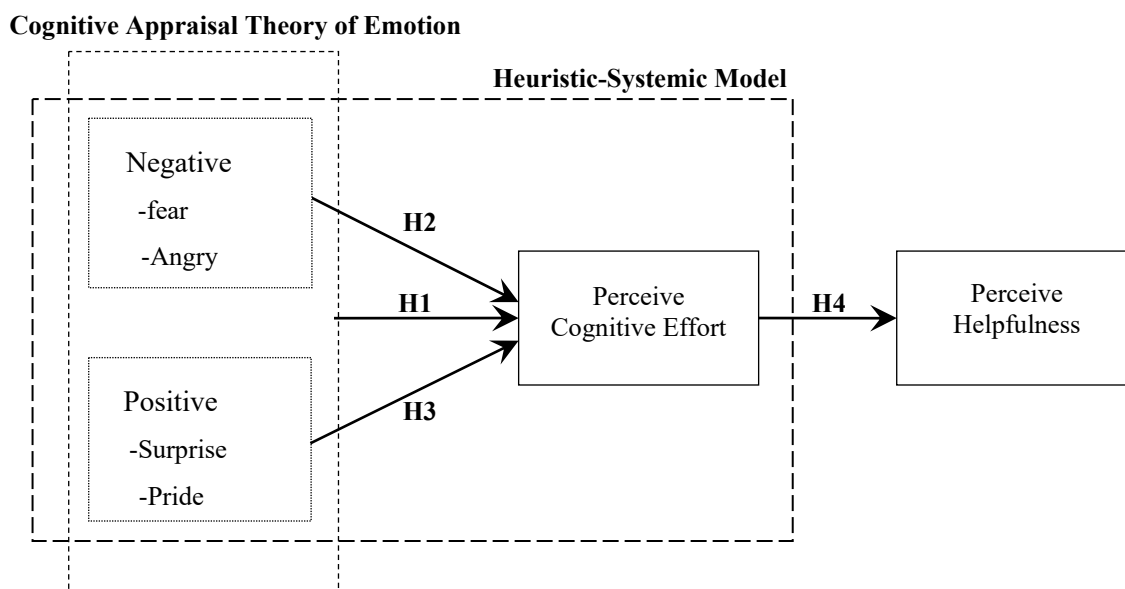

Figure 1: Research Model

Emotion is linked to cognitive process and occurs following cognitive processing (Holbrook and Hirschman, 1982). Specifically, an emotion-charged process is sensibility-oriented, with the purpose of transmitting the sender's emotional state, such as happiness, sadness, and anger, to the recipients (Söderlund and Rosengren, 2007). Park and Lee (2009) suggested that, compared to online reviews with positive emotions, the reviews with negative emotions are often seen by readers as more influential. These asymmetric influences between positive and negative emotions are attributed to the fact that online reviews with negative emotions tend to include more diagnostic features associated with the given product/service, and are more informative (Lee et al., 2008). This inference is consistent with research on impression formation, which states that individuals are inclined to pay more attention to negative rather than positive messages (Skowronski & Carlston, 1989). Therefore, this study proposes the hypothesis:

Hypothesis 1 (H1): Negative emotion lead to higher perceive cognitive effort than positive emotion.

Readers' perceived cognitive effort of a given online product review tends to vary from other emotional patterns contained within the messages. The negative emotions involved in this study included fear and anger. According to the cognitive-appraisal table, both emotions have a low level of pleasantness, and a high level of anticipated effort. Fear is the most common emotional state triggered when an individual is trying to avoid being

hurt by an uncertain threat. Anger is triggered by the negative influence of a given situation, where individuals take, or intend to take, action to confront the stimulus (Lazarus, 1991). According to HSM, online product reviews containing anger suggest that the reviewers perceive a higher degree of certainty, or individual control, during the consumption process of the given product/service; hence, he/she is likely to apply heuristic processing. On the contrary, when an online product review implies fear, the reviewer tends to perceive a lower degree of certainty and individual control during the consumption process of the given product/service; thus, he/she is likely to adopt systematic processing (Tiedens & Linton, 2001). Based on the above deduction, the study assumed that, when the negative emotions conveyed by online reviews are related to fear, the readers are likely to perceive that the reviewer has spent greater cognitive effort than when the conveyed negative emotion is anger. Therefore, this study proposes the second hypothesis:

Hypothesis 2 (H2): Fear emotion lead to higher perceive cognitive effort than angry emotion.

Surprise refers to the mental state when an individual generates happiness under an unexpected event or situation (Yin et al, 2014). Pride is the mental state when an individual achieves the desired goal and thereby generates self-recognition and a sense of achievement (Yin et al, 2014). According to the cognitive appraisal, surprise is lower in the degree of certainty and individual control than pride. For reviewers, the consumption process, when accompanied with surprise, tends to be more interesting than that accompanied with pride; hence, the likelihood of applying systematic processing when experiencing surprise tends to be greater. According to the HSM, when a reviewer perceives a higher degree of certainty or individual control during the consumption process of the given product/service, he/she is likely to apply heuristic processing. On the contrary, when the reviewer perceives a low degree of certainty and individual control during the consumption process of the given product/service, he/she is likely to adopt systematic processing (Tiedens & Linton, 2001). Based on the above inferences, this study assumes that, when the positive emotion conveyed by the online reviews is surprise, the readers are likely to perceive the reviewer as having spent greater cognitive effort than when the conveyed positive emotion is pride. Hence, we put forward the following hypothesis:

Hypothesis 3 (H3): Surprise emotion lead to higher perceive cognitive effort than pride emotion.

When readers believe that the reviewers have put a significant amount of cognitive effort in their reviews, they tend to perceive the drafted reviews as helpful (Yin et al., 2014). Kim and Gupta (2012) claimed that attribution theory could be applied to explore how observers deduce causes and causal relationships based on behaviors of others. Therefore, asserting that readers can deduce the effort invested by the reviewer based on the review content is consistent with the viewpoints of performance estimation theory. On that account, under different contexts, an individual's attribution tendency can establish a direct relationship between invested effort and the execution of that effort. Furthermore, Mudambi and Schuff (2010) pointed out that writing a product/service review is a challenging task. Readers' perceived effort may be seen as the primary motive for individuals' input in this task. In light of the aforementioned theories, we assume that readers' perceived cognitive effort that the reviewer invested in writing the review could affect their perceived helpfulness of the review. Therefore, this study proposes the hypothesis:

Hypothesis 4 (H4): The more perceive cognitive effort lead to the higher perceive helpfulness.

RESEARCH METHOD

To test the research model, we conducted a laboratory experiment that directly manipulates emotion express in restaurant service reviews. The experimental website was designed to mimic the website iPeen (<http://www.ipeen.com.tw>), the largest, third-party restaurant-review platform in Taiwan. iPeen is Taiwan's most influential restaurant review platform. There are four scenarios design (angry, fear, surprise and pride) to create WOM stimuli. Each scenario comprised an encounter with a customer who was transmitting WOM about a restaurant service, and we exposed each of subjects to one of the four scenarios. Perceived cognitive effort is measured and studied as mediating variable. Perceived usefulness is measured as a dependent variable. A total of 196 undergraduate business students at a major university are recruited in exchange for extra credit. During the two months of data collection, 216 participants had been recruited. After excluding 20 invalid responses, 196 completed samples were collected for further analysis. Among the qualified participants, 86 were male and 110

were female. The majority of the participants were between 18 and 24 years old. Their average frequency of shopping online per week was 1 to 3 times (60.4%). More participants spent over 40 hours per week (34.3%) and spent NTD 301 to 600 per purchase (30.1%).

DATA ANALYSIS AND RESEARCH RESULT

To ensure the accuracy of the results, we tested the reliability and validity of the questionnaire. An exploratory factor analysis (EFA) was introduced to obtain the factor loadings. According to Hair et al. (1998), if the loading of each factor is greater than 0.4, then it can be considered that no cross loadings were present. The factor loadings are all greater than 0.4, indicating that the items were loaded based on expected constructs, and all items had both convergent and discriminant validity. Next, the Cronbach's α was utilized to measure the reliability of the questionnaire. Nunnally (1978) suggested that a Cronbach's α of greater than 0.7 indicates a satisfactory reliability. The Cronbach's α of perceived cognitive effort was 0.84, and that of perceived helpfulness was 0.94, indicating that the instrument had a high degree of consistency and stability.

A single-factor analysis of variance (ANOVA), independent sample t-test, and linear regression analysis were used to test the hypotheses proposed in the study. The single-factor ANOVA was adopted to test H1 (the impact of the implied positive and negative emotions in the reviews on readers' perceived cognitive effort). The results showed that reviews with a different valence of emotion could lead to different levels of perceived cognitive effort ($p < 0.01$). Specifically, reviews with negative emotions appear to be perceived as having been invested with more effort than those with positive emotions; hence, H1 was supported. The independent sample t-test was performed to examine the differences in readers' perceived cognitive effort when the implied negative emotion in the review was anger and when the implied emotion was fear. The results showed a noticeable difference between the two means ($t_{(99)} = 4.237, p < 0.01^{**}$), and reviews conveying fear were perceived to have been invested more in than those conveying anger; thus, H2 was supported. The same method was also applied to examine the differences in the perceived cognitive effort between reviews showing surprise and pride. The findings revealed a noticeable difference between the two emotional expressions ($t_{(93)} = 3.675, p < 0.01^{**}$); the perceived cognitive effort spent by the reviewers in the reviews expressing surprise was greater than that showing pride; thus, H3 was supported (Table 1). The results of Levene's test showed that the homogeneity of the two groups of variances was not significant (positive emotions: $F = 2.502, p > 0.05$; and negative emotion: $F = 3.49, p > 0.05$). In the negative emotion, reviews containing content indicative of anxiety were considered more helpful than those containing content indicative of anger. In the positive emotion, reviews containing content indicative of surprise were considered more helpful than those containing content indicative of pride. Therefore, H2 and H3 are supported.

Table 1: The results of independent sample t-test

Dependent Variable		Perceive Cognitive Effort		t-test		
		Mean	SD	t-Value	df	p-Value
Negative Emotion	Fear (n=50)	5.4	1.05	4.237	99	0.003**
	Anger (n=51)	4.6	0.85			
Positive Emotion	surprise (n=45)	4.8	0.95	3.675	93	0.008**
	pride (n=50)	4.2	1.38			

** $p < 0.01$, * $p < 0.05$

Lastly, regression analysis was introduced to investigate the impact of readers' perceived cognitive effort invested by the reviewer on their perceived helpfulness of the reviews. The standard coefficient of perceived cognitive effort was 0.68 ($p < 0.000^{***}$), and the adjusted R^2 was 0.38. Falk and Miller (1992) suggested that an explanatory power greater than 10% is considered acceptable. Hence, the results show that perceived cognitive

effort could explain a large proportion of the variance of perceived helpfulness, indicating that perceived cognitive effort has a significant, positive impact on perceived helpfulness. H4 was therefore supported. Table 2 summarizes the test results of the proposed hypotheses in this study.

Hypotheses	Results
Hypothesis 1: Negative emotion lead to higher perceive cognitive effort than positive emotion.	Supported
Hypothesis 2: Fear emotion lead to higher perceive cognitive effort than angry emotion.	Supported
Hypothesis 3: Surprise emotion lead to higher perceive cognitive effort than pride emotion.	Supported
Hypothesis 4: The more perceive cognitive effort lead to the higher perceive helpfulness.	Supported

Table 2: Summary of Hypotheses Testing

DISCUSSION AND IMPLICATIONS

The present study mainly intended to explore the influence of implied emotional expression in online product reviews on readers' perceived helpfulness of the reviews. The results show that readers' perceived cognitive effort invested by the reviewer positively affects readers' perceived helpfulness of the review. Our results are consistent with the findings of Yin et al. (2014). When readers perceive that the reviewer has spent more time and effort to write the review, and has spent time thinking before writing the review, then, they are more likely to consider the review useful. In addition, this study also found that readers tend to perceive more cognitive effort invested by the reviewer when the emotions conveyed by the review were negative, compared to when the emotion conveyed was positive. The main reason may be that negative reviews tend to include more diagnostic features associated with the product/service, as well as being more informative; hence, readers are inclined to pay more attention to negative rather than positive reviews. Moreover, compared to reviews conveying anger, readers have a tendency to perceive greater cognitive effort being invested in reviews implying fear. Compared to reviews showing pride, readers have a tendency to perceive greater cognitive effort being invested in reviews showing surprise.

Implications

This study has theoretical and practical implications. First, from the theoretical implications, this study extend the research design proposed by Yin (2014), and in addition to retaining anger and fear (negative emotions) in the study, we also included pride and surprise (positive emotions). The results were consistent with the cognitive appraisal theory of emotion, and when compared to that in the field of information systems, there were more distinctive emotions included in online reviews, which convey the same valence of emotions, affecting individuals' choices and decision-making in different ways. Besides, this study applies an HSM to explore how consumers are affected by a specific context/service and thereby generate different emotions, which are then reflected in their online product reviews through the corresponding cognitive effort. More precisely, when a reviewer applies heuristic processing, he/she is in a consumption context of high certainty and individual control, which may induce anger (negative) or pride (positive). On the other hand, when the reviewer applies systematic processing, he/she is in a consumption context of lower certainty and individual control, which may induce fear (negative) or surprise (positive).

Secondly, from the practical implications, the findings of this study have provided operators of review-based platforms information supporting the idea that reviews with various emotions may affect readers' perceived helpfulness. It is recommended that platform operators establish a review-assisting system, which provides reviewers with images or words that can help reviewers express their emotions more precisely, so that

the reviews can be more helpful for readers. It is also recommended that the platform operators establish a reward system, using peer voting to select the most helpful reviews and offer a reward accordingly, so as to encourage other reviewers to provide the same good quality reviews. In addition, retailers and service providers can also learn from the results that, even though a review is negative, it may lead to substantially differentiated perceptions from reviewers and readers. In addition, retailers and service providers can also learn from the results that, even though a review is negative, it may lead to substantially differentiated perceptions from reviewers and readers. Generally, consumers that are angry about their consumer experience tend to take, or intend to take, actions to confront the stimulus, whilst consumers experiencing fear during the process are more likely to act passively and retrogressively.

LIMITATIONS

This study utilized a laboratory experiment method and the results indicate that reviews with specific emotions can lead to various levels of perceived cognitive effort and thereby affect the perceived helpfulness of the review. In order to avoid potential interference of factors that affect the reliability of the results, certain measures were adopted to manipulate such factors. However, there are still a few limitations. First, participants of the experiment were a highly homogeneous group of individuals (university students). Although using a homogenized group for theoretical testing tends to give more satisfactory results, the generalization of the findings to other population groups may be affected. Therefore, it is recommended that future studies conduct the investigation among users of specific Internet platforms. Secondly, this study only examined one product/service (restaurant service); however, there are more products and services that use online reviews on their systems/platforms. Hence, caution is needed when applying the findings of this study to other product/service categories. Future studies can include more variety of product types.

CONCLUSION

The major objective of this study was to investigate the effects of emotions expression of online reviewer on the perceived helpfulness of review readers. This study enriches the existing literature by proposing a theoretical model. The finding of this research also useful for practitioner in understanding their consumer's perceived. In addition, the majority of past studies tended to use an econometric approach, and focused on the analysis of information that was objective and easy to access. This study, however, adopts a laboratory experiment approach, by manipulating the emotional expression of online reviews to explore the impact of various emotional expressions on readers' perceptions. Therefore, the results of this study have amassed the findings from the fields of both marketing and information systems, and can be used as a reference for future research.

REFERENCES

- Baek, H., Ahn, J-H. and Choi, Y. (2013). Helpfulness of online consumer reviews: Readers' objectives and review cues. *International Journal of Electronic Commerce*, 3(2), 166-178.
- Cao, Q., Duan, W. J. and Gan, Q. (2011). Exploring determinants of voting for the "helpfulness" of online user reviews: a text mining approach. *Decision Support System*, 50(2), 511-521.
- Chaiken, S. (1987). The heuristic model of persuasion. In M. P. Zanna, J. M. Olson, & C. P. Herman (Eds.), *Social Influence: The Ontario Symposium* (Vol. 5, pp. 3-39). Hillsdale: Erlbaum
- Falk, R. F. and Miller, N. B. (1992). *A Primer for Soft Modeling*. Akron: University of Akron.
- Forman, C., Ghose, A. and Wiesenfeld, B. (2008). Examining the relationship between reviews and sales: The role of reviewer identity disclosure in electronic markets. *Information Systems Research*, 19(3), 291-313.
- Frijda N. H. (1986), *The Emotions*. Cambridge, UK: Cambridge Univ. Press
- Ghose, A., and Ipeiritos, P. (2011). Estimating the helpfulness and economic impact of product reviews: mining text and reviewer characteristics. *IEEE Transactions on Knowledge and Data Engineering*, 23(10), 1498-1512.
- Hair, J.F. Jr., Anderson, R. E., Tatham, R. L., Black, W. C. (1998). *Multivariate Data Analysis* (5th ed.) ,Englewood Cliffs, NJ : Prentice-Hall.
- Holbrook, M. B., and Hirschman E. C. (1982). The experiential aspects of consumption: consumer fantasies, feelings, and fun. *Journal Consumer Research*, 9(2), 132-40.
- Kim, J. Y. and Gupta, P. (2012). Emotional expression in online user reviews: how they influence consumers' product evaluations. *Journal of Business Research*. 65(7), 985-992.
- Lazarus, R. S. (1991). *Emotion and Adaptation*. New York: Oxford Univ. Press.
- Lee, A. and Sternthal, B. (1999). The effects of positive mood on memory. *Journal of Consumer Research*. 26(2), 115-127.
- Lerner, J. S., Li, Y. Valdesolo, P. and Kassam, K. S. (2014). Emotion and decision making. *Annual Review of Psychology*, 66, http://scholar.harvard.edu/files/jenniferlerner/files/lerner.li_valdesolo.kassam_in_press_annual_review_emotion_and_decision_making_edited_proof.9.29.2014.pdf , accessed on November 15, 2014.
- Mudambi, S. M. and Schuff, D. (2010). What makes a helpful online review? A study of customer review on Amazon.com. *MIS Quarterly*, 34(1), 185-200.
- Nunnally, J.C. (1978). *Psychometric Theory*, New York: McGraw-Hill.
- Pan, Y. and Zhang, J. Q. (2011). Born unequal: a study of the helpfulness of user-generated product reviews. *Journal of Retailing*. 87(4), 598-612.
- Park, C. and Lee, T. (2009). Information direction, website reputation and eWOM effect: a moderating role of product type. *Journal of Business Research*. 62(1), 61-67.
- Roseman, I. J. (1984). Cognitive determinants of emotion: A structural theory. *Review of Personality & Social Psychology*. 5, 11-36.

- Söderlund, M., and Rosengren, S. (2007). Receiving word-of-mouth from the service customer: An emotion-based effectiveness assessment. *Journal of Retailing and Consumer Services*. 14 (2), 123-136.
- Schlosser, A. E. (2011). Can including pros and cons increase the helpfulness and persuasiveness of online reviews? The interactive effects of ratings and arguments. *Journal of Consumer Psychology*. 21(3), 226-239.
- Silverman G. (1997). How to harness the awesome power of word-of-mouth. *Direct Marketing*. 60(7), 32-37.
- Söderlund, M., and Rosengren, S. (2007), "Receiving word-of-mouth from the service customer: An emotion-based effectiveness assessment," *Journal of Retailing and Consumer Services*, 14 (2), pp. 123-136.
- Skowronski, J. J., and Carlston, D. E. (1989). Negativity and extremity biases in impression formation: A review of explanations. *Psychological Bulletin*. 105, pp. 131-142.
- Solloway, (2010). The emotional-cognitive processing model," <http://www.american.edu/soc/communication/upload/Solloway2010.pdf>, accessed on November 15, 2014.
- Tiedens L. Z. and Linton, S. (2001). Judgment under emotional certainty and uncertainty: the effects of specific emotions on information processing. *Journal of Personality and Social Psychology*. 81(6), 973-988.
- Wan, Y. and Nakayama, M. (2014). The reliability of online review helpfulness. *Journal of Electronic Commerce Research*. 15(3), 179-189.
- Wu, P. F., Heijden, H. and Korfiatis, N. T. (2011). The influences of negativity and review quality on the helpfulness of online reviews. International Conference on Information Systems, Shanghai.
- Yin, D., Bond, S. and Zhang, H. (2014). Anxious or angry? Effects of discrete emotions on the perceived helpfulness of online reviews. *MIS Quarterly*. 38(2), 539-560.

Acknowledgements

This study was supported by Ministry of Science and Technology, Taiwan, R. O. C. (MOST 105-2410-H-270-003)

THE ROLE OF GOVERNMENT IN THE IMPLEMENTATION OF SUSTAINABLE DEVELOPMENT INITIATIVES BY ADVENTURE TOURISM SMMEs IN SOUTH AFRICA: AN EXPLORATORY INQUIRY

Norman Chiliya
University of Witwatersrand, South Africa

Cecile Nieuwenhuizen and Darelle Groenewald
University of Johannesburg, South Africa

ABSTRACT

Sustainable development suggests that there are restrictions to the obtainability of ecological resources and the planet to engage human activities. Limited South African research exists in the field of sustainable development in adventure tourism SMMEs especially the role of Government in terms of implementation of sustainable development initiatives. A structured questionnaire was administered via email and hard copies. A total of 105 usable responses were received. Government, business associations and certification bodies have unrelated methods for evaluating sustainability issues. The tourism sector is overwhelmed with initiatives and certifications intended at facilitation and adoption of sustainable development practices. This adds to the confusion that entrepreneurs face when it comes to choosing an appropriate tool. There is consensus that entrepreneurs want to develop their sustainability knowledge base. It is recommended that the different institutions or actors in the arena of sustainable development should make information on sustainable development easily available. The SMMEs also indicated that the legislative framework affecting small businesses should be improved. The government, should award rebates to SMMEs for implementing sustainable development initiatives. Alternative funding for implementing sustainable development initiatives should also be established.

Keywords: sustainable development; small business and business performance.

INTRODUCTION

Not only do people express their economic and social aspirations and demands through political channels, but their detailed environmental and cultural knowledge also finds expression through politics. Think of the world as being constituted by great environmental and cultural diversity then detailed knowledge of local realities declines to the degree that social actors are situated further away from the locality in question. Grassroots democracy involves much more than local people lobbying the state or international agencies for their fair share of global development (Prugh, Costanza and Daly, 2000,p15; Yasarata, Altinay, Burns and Okumus, 2010,p345; Farmakis, Altinay, Botterill and Hilke, 2015,p178).

“Political will is an important factor in the application of any major policy initiative. Public pressure cannot only help to create political will, it can also be a cherished tool for dedicated politicians to use in persuading associates. Voted representatives recognise public pressure very well and often act upon it, a fact which elucidates

why politicians are keen readers of public opinion polls. At this stage, the implementation of sustainable development still requires a substantial amount of political will, and public pressure in support of sustainable policy decisions, therefore, becomes desirable. The social impact can either be positive, e.g. corporate giving, creation of employment or negative, e.g. work accidents, beating of employees, human rights abuses” (Yasarata et al., 2010,p345).

“The public also wishes to be well knowledgeable, a not unimportant mission when it comes to such a multifaceted and often technical area such as sustainable development. Better communication of policy issues, greater transparency in the policy process, and the ability of citizens to contribute in a meaningful way when important decisions are made, all of these are crucial to public support for sustainable development initiatives” (Lamb, Hair, McDaniel, Boshoff, Terblance, Elliot and Klopper, 2010,p567).

Making decisions about sustainable development is no longer the sole responsibility of governments. There is increasing acknowledgement in academic and business publications of a shift to a more all-inclusive concept of control, which embraces the contributions of various levels of government, private sector, non-governmental actors, and civil society. The more sustainable development issues are mainstreamed as part of the planning viewpoint at the suitable level of implementation, and the more all applicable parties are involved in the decision making process in a significant way, the more likely they are to realise the desired objectives (Perez and Del Bosque., 2014,p176). Perez et al., (2014, p176) also states that government regulations are perhaps the most substantial driver for SMMEs to make environmental enhancements.

Metz, Davidson, Bosch, Dave and Meyer (2007a, p1) state that concerning governments, a considerable body of political theory recognises and elucidates the presence of national policy styles or political cultures. The primary hypothesis of this study is that separate countries tend to process teething troubles in a specific manner, irrespective of the uniqueness or specific features of any problem; a national ‘way of doing things’. Also, the choice of policy tools is affected by the institutional capacity of governments to implement the tool. This implies that the preferred mix of policy decisions and their effectiveness in terms of sustainable development strongly rest on national characteristics. Matters such as cognizance of government regulations for sustainable development and compliance with relevant government regulations regarding sustainable development will be evaluated. The study will also try and establish whether SMMEs receive incentives (e.g. tax reductions and subsidies) from government for implementing sustainable development projects

Crals and Vereeck (2005,p11) points out that a vast majority of SMEs are inactive when it comes to the application of the sustainable development concept. Crals et al., (2005,p11) go on to state that in 2000, only 0.1% of European SMEs had accredited environmental management systems, such as ISO 14001 or Eco-Management and Audit Scheme (EMAS). Although eco-efficiency schemes have stretched to tens of thousands of businesses, the uptake merely represents an insignificant portion of the millions of SMEs. The attitude towards the environment and the understanding of sustainable development remains very poor. SMEs as a cluster have not been convinced that committing funds to obtain an ISO certificate is an important business decision (Perez et al., 2014, p177). For most SMEs, a lack of assets, time, employees, and funds is quite common. Hence in most cases the focus of sustainable development efforts have been on large businesses.

A record number of literature focusing on sustainable development, whether the studies take into account of SMEs or not, concentrate on the environment dimension only (Courent, Spence and Temri. (2009,p1). By way of restricting the inquiry to merely one feature of sustainable development out of four, this methodology overlooks relationship of environment, society, politics and economy. Addressing sustainable development requires a holistic approach incorporating all factors that constitute sustainable development

THE RESEARCH PROBLEM

SMMEs are usually “struggling to endure under hostile economic conditions and any rules tend to be heavier than for larger businesses that have the funds to deal with regulations”. Jones (2013, p1) states that “one of the most frequently raised issues was the burden of compliance with regulations, which diverts attention away from a business’s core activity. Businesses employing fewer than 21 people were spending 5% of turnover dealing with red

tape. SMMEs employing 21-30 employees spent 2%; SMMEs employing 31-40 slightly less than 3%; and SMMEs employing more than 40 employees were spending a little over 2%". Jones (2013:1) further states that SMMEs have to comply with more than 45 laws and submit 24 returns a year. This is time consuming and costly, especially if they need specialist help. Jones (2013, p1) also states that "it can take up to eight months before the small business start-up is compliant. SMME managers to be precise are probably apprehensive of the consequences of social and environmental issues and regulations. SMMEs will identify them to be an added burden, unless the business argument is made in a language and in a form that can be understood. As in the case of larger businesses, it must be made known that it can be an effective tool, for the same reasons, but with very different emphasis. It will be less a matter of education and more an issue of responsiveness and altering perceptions over the effects of sustainable development for the business" (Cucculelli and Goffi, 2016,p370). A dominant characteristic of sustainable development which is frequently disregarded, is the influence of government in terms of the implementation of sustainable development.

Given the brief background on sustainability and the low levels of implementation in South Africa, the research questions can be phrased as follows:

- Will the adoption of the sustainable development concept by SMMEs contribute to an enhanced business performance in South Africa?
- What is the role of government the implementation of the sustainable development concept in adventure tourism SMMEs in South Africa?

METHODOLOGY

Research design

Descriptive and explanatory analysis is the format that this study adopted. Descriptive studies are typically and specifically intended to quantify the features defined in research questions (Hair, Babin, Money and Samouel, 2007, p193). Descriptive research is meant to make available explanations of occurrences or characteristics regarding a subject of a population and estimates of the proportions of a population that have those characteristics and discovery of associations among different variables (Babbie, Mouton, Vorster and Prozesky, 2010:460).

The population under investigation in this study was all the owners/managers of adventure tourism SMMEs in South Africa. The population size was obtained from the Dirty Boots Database that includes various associations in the adventure tourism industry, since there is no single association that comprehensively represents adventure operators in South Africa. The list is not exhaustive of all tourism establishments in South Africa. This has been a concern for a number of studies that have been conducted using tourism SMMEs as frame of reference (Rogerson, 2005, p623). To minimise certain of the well-known limitations related to the use of directories including imperfect and out-of-date entries by verifying and editing the generated study frame.

The study made use of a non-probability, purposive or judgemental sampling technique. In purposive or judgmental technique, an individual selects the sample based upon some appropriate characteristic of some sample members (Babbie et al., 2010, p166). The sample is drawn from adventure tourism SMMEs in South Africa. The sample size was 305 Adventure tourism SMMEs.

The time dimension of the study is cross-sectional. The research was conducted in the field environment of South Africa adventure tourism business.

The research study made use of self-administered questionnaires. Self-administered questionnaires can be in the form of a postal survey; a questionnaire sent through an email or a questionnaire hosted on the internet often referred to as CSAQ, computerised self-administered questionnaire. A computerised system accepts the respondent's answers. Babie et al. (2010, p258) state that self-administered questionnaires are only appropriate when the population under study is adequately literate. For SMMEs in the Gauteng area the researcher administered hard copies of the research questionnaire. Self-administration of questionnaires in the Gauteng area improved the response rate since the researcher will be able to clarify issues if they arise. The online questionnaire was used to

collect data from respondents beyond the reach of the researcher. The researcher made use of Dirty Boots database of adventure tourism SMMEs.

The questionnaire also adopted some questions from the instruments designed by Dzansi (2004), Seidel et al. (2009) and Shi, Peng, Liu and Zhong (2008) which had been tried and tested. The data from the questionnaires was analysed using descriptive statistics.

RESULTS

Type of registration of the Adventure tourism SMME

The majority of the businesses (67.3 %) are close corporations. Registered companies represent 10.6%, partnerships 12.5% and 9.6 % of the businesses are not registered and operate as informal businesses. Close corporations are no longer registered in South Africa, since 2012.

According to the number of years the SMME has been in operation, 35 % have been operating for between 6-10 years. The findings from this study mirror those of Rogerson (2007: 234), who found that the average length of business operation was 5.7 years. When businesses that are five years old and above are combined, 83 % of the business exist for more than 5 years, a good survival rate of adventure tourism SMMEs.

Waste management and water management receive attention from most of the SMMEs in the sample. It is encouraging that SMMEs are already implementing some aspects of sustainable development. However, only a small fraction (7 %) of the respondents has implemented sustainable development initiatives successfully.

It is encouraging that a total of 19.2 % have prioritised the implementation of sustainable initiatives. However, the majority 59.6 %, of the adventure tourism businesses do not regard implementation of sustainable business as a priority whereas 6.7 % are not even considering implementing sustainable development initiatives in their operations. The low uptake of implementation of sustainable development initiatives is not unique in South Africa. Haskins (2009,p1) established that the bulk of small- to medium-sized enterprises (SME) are normally not covered in the sustainable development discussions. For instance, a sampling of occupants in a rural Norwegian industrial park point out that the bulk had on no occasion heard the expressions corporate responsibility or sustainable development. A study by the Hong Kong University of Engineering Alumni Association (HKUEAA) (2007, p1) found that there is a general lack of sustainable development understanding in Hong Kong. Most SMEs are unaware that sustainable development practices could increase their competitiveness in the market place. Revell, Stokes and Chen (2010;p1) state that in the United Kingdom a great percentage of owner-managers are now vigorously involved in recycling, energy efficiency, responsible buying and selling and efforts to reduce carbon dioxide. Few small businesses saw the need to adopt an integrated environmental policy. Of those respondents who did not undertake any “greening” actions, most had not felt it necessary to act, others did not see what they personally could do and some simply did not get to do anything about it.

Walker, Wang and Redmond (2008, p278) state that participation by SMEs in corporate social responsibility issues has been found to be deficient. This is a critical issue, as independent SMEs may have diminutive impact on the environment, but their combined footprint is substantial. The management style and ethical stance of the owner-manager affects business decision making and, therefore, has a direct impact on the environmental actions of the business. Although adoption of environmental practices to create competitive advantage has been advocated, many businesses see implementation as a cost which cannot be transferred to their customers.

Customers (36.5 %) are very influential in terms of implementing sustainable development practices. Government regulations (27.2 %) are also instrumental in making sure that business owners comply with sustainable development initiatives whereas suppliers (11.5 %) have some, but limited influence.

Only 4.9 % of the respondents have implemented ISO900 standards and 4 % have implemented other standards. The findings are almost similar to a study by Jarvis, Weeden and Simcok (2010, p83) who determined that SMMEs in England also battle with the implementation of Sustainable Tourism Certification due to factors such as lack of knowledge of the sustainable development concept, the perceived expense of applying for membership and a lack of time to complete the membership process.

Regarding the influence of government regulations on SMME's operations, 93.3 % are aware of the government regulations regarding sustainable development and 66% acknowledge that the regulations have an influence on the business. The majority of the SMEs (90.4 %) also state that they comply with government regulations regarding sustainable development and also acknowledge that compliance has an effect on their business. A small number of SMMEs (4.9 %) receive incentives (e.g. tax incentives and subsidies) from government for implementing sustainable development projects. According to Schoof (2006,p2), even in the United Kingdom entrepreneurs often lack the support and do not make use of government support services. In most cases, they are not cognisant of the variety of public, and private business support services or are simply confused regarding the service. If the moderately important and very important responses are combined, a total of 72.2% of the respondents would agree that incentives have a significant influence on the operations of their business. Thirty three percent of SMEs are actively involved with the government in formulating laws relating to sustainable development while 74.8 % agree that involvement in formulation of laws is important to their organisations. Turton and Herrington (2012,p77) indicated that to encourage entrepreneurship development, the government should be encouraged to support new businesses, remove the burdensome labour laws, better tax breaks are needed for early-stage entrepreneurs to decrease the cost of doing business during the start-up phase. They further state that policies could be broadened to ensure that funding is available to new viable and growing business through banks and reduce the bureaucratic application process currently in existence. Fatoki (2014, p161) highlights that perceived lack of support especially by government is another obstacle to the development of entrepreneurship in South Africa. Government plays a vital role in creating a conducive atmosphere for business to thrive and drive the economy towards economic prosperity. Government has launched so many programmes for the development of entrepreneurs, but the uptake of such programmes is very low. Of the SMMEs in this study only 4.9 % receive tax subsidies. The challenge is that entrepreneurs are unable to receive the incentives and face difficulties in getting assistance.

The results indicate that government factors have an influence on the financial performance of SMMEs involved in the study. A total of 66 % of the SMEs indicated that government has an influence on their financial performance. Government regulations also have an influence on the non-financial performance of their operations (64.5%). Half of the respondents indicated that getting incentives has an influence on the financial performance of the business and 43.8% indicated that getting incentives is influential on the non-financial performance of the business. A total of (72.7 %) of the respondents indicated that being actively involved in formulating laws has a strong influence on the financial and 75% on the non-financial performance of the business. In summary, it is clear that government does have influence on the financial and non-financial performance of the business operations.

Regarding the influence of government regulations on SMME's operations 92.1 % of respondents indicated that there are too many government regulations and 91.2% indicated that these regulations are confusing and costly to implement (96.1 %). This could explain the low adoption of environmental standards. The SMMEs also state that there are too many certification programs that are available (97.0 %). This confuses the SMMEs as to which certification product they should adopt. Blame is also placed on government that does not make information regarding sustainable development easily available (93.1 %). A further (88 %) of the respondents indicate that government does not enforce regulations regarding sustainable development. The factors mentioned above have a very negative effect on the business. Action should be taken to remedy the problems identified.

MANAGERIAL IMPLICATIONS

Low uptake/implementation of sustainable development initiatives

SMMEs in South Africa still regard the implementation of sustainable development as a “nice to have” instead of a “must have”. In the study only 7 % of the respondents have implemented sustainable development initiatives successfully. A total of 19.2 % have prioritised the implementation of sustainable initiatives. Only 4.9 % of the respondents have implemented the ISO900 standard and 4 % have implemented other standards. The low levels of implementation can be attributed to lack of information on sustainable development. The respondents also indicated that they are not aware of sustainable development implementation agencies in the country. The respondents also shifted the blame on government for not making information on sustainable development available.

In the light of the above it is recommended that the Ministry of Small Business in South Africa be modelled along the United States Small Business Administration. Currently, the Ministry of Small Business in South Africa does not have a website. The United States Small Business Administration has a learning centre with vast resource videos, online resources and also a chat facility for entrepreneurs who reside in areas where there are no offices. The entrepreneurs can also learn at their own pace without leaving their business. If one explores the Small Enterprise Development Agency (SEDA) website there is no information on sustainable development. The information under the research tab was last updated in 2013.

Strengthen and improve legislative framework supporting SMMEs

SMMEs in the study (48 %) feel that there are too many regulations regarding sustainable development in South Africa. A further 42.3 % of the respondents indicated that regulations regarding sustainable development implementation are confusing. Apart from that 47 % of the respondents are of the view that sustainable development implementation regulations are costly to implement. The SMMEs also lament the existence of too many certification programmes, thus calling for a revisit of the existing regulation framework.

South Africa should study from the knowledge of developed countries, research and implement a series of laws and regulations to support the development of small and medium-sized enterprises, such as "SMEs Basic Law", "SMEs Promotion Law". The laws should be tailor made to suit SMMEs. This will lead to establishing the rights and obligations of small and medium-sized enterprises, to regulate the conduct norms for small and medium-sized enterprises, to lay a legal foundation for healthy development.

Furthermore, the government was blamed for not enforcing regulations regarding sustainable development. This implies that SMMEs can easily get away with their unsustainable practices. As alluded to earlier, amalgamating the different small business development agencies will lead to more manpower to enforce regulations on sustainable development.

Rebates for implementing waste management and energy conservation systems

In terms of waste management systems a lot of SMMEs are currently doing well. This is also similar for energy and water management. This implies that SMMEs should be rewarded for efforts that they are currently implementing. Tourists are likely to re-visit a clean establishment rather than a dirty establishment. However, only 7 % of the respondents collaborate with Eskom for example. This implies that SMMEs are not taking advantage of the subsidized prices offered by Eskom. On the other hand, maybe Eskom needs to also have the same concessions it has for large mining corporations for small businesses in South Africa. SMMEs should also be encouraged to use recyclable material. The SMMEs should also try and use new equipment that minimises the emission of carbon dioxide.

Improve financial support aimed at SMMEs to engage in sustainable development initiatives

South Africa's financial support to SMMEs consists mainly of financial subsidies, the Government's earmarked funds, and the Government procurement policy. In South Africa there are no specific tax policies for small and medium-sized enterprises, and only in the income tax, value-added tax, sales tax, and depreciation policy to make the tax provisions to benefit small and medium-sized enterprises. Suitable tax and subsidy policies should be designed to encourage uptake sustainable tourism activities and discourage unsustainable tourism. Use of tax is will result in improvements of infrastructure (for example, taxes on use of resources and services at the destinations) and controlling the specific inputs and outputs (like effluent charges and waste services). The money can be channelled back to improve the community.

Cooperation with customers and suppliers

Synergies in the tourism sector could be achieved by means of cooperation. Buyers and suppliers in most cases would like to deal with SMMEs that are compliant with sustainable initiatives because this also has an effect on their businesses. Sound sustainable business practises is a significant input by those companies that follow competitive advantages based on sound sustainable development management. In the case of tourism, the conservation of the natural capital of a country has a chain effect and corresponding influence on many SMMEs. Cooperation can make stronger backward and forward linkages in the tourism value chain and drive sustainability in the whole industry.

LIMITATIONS OF THE STUDY

The limitation of this study may be argued to be the sample size of the survey; but it is also reasonable to stress the creditability and initiative of the study due to the homogeneous characteristics of South African SMMEs. However, a larger number of samples will definitely provide a more creditable and useful source of reference. Similar tourism studies have low response rates as well.

Secondly, findings and conclusions may not be applicable to all other industries. Finally, the responses analysed to obtain the findings of this study are based on the opinions and experiences of the respondents. There is always a chance that the interpretation of these opinions and experiences is not accurate.

REFERENCES

- Babbie, E., Mouton, J., Vorster, P. & Prozesky, B. (2010). *The practice of social research*. Cape Town: Oxford University Press Southern Africa.
- Courent, J.M., Spence, M. & Temri, L. (2009). *Small business and sustainable development*. [Online]. Available from: <http://www.ifsam2010.org/tracks/ifsam2010COURENTandSPENCEandTEMRI.pdf> [Accessed on: 29 Jan. 2012].
- Crals, E. & Vereeck, L. (2005). The affordability of sustainable entrepreneurship certification for SMEs. *International Journal of Sustainable Development and World Ecology*, 12(2):173-184.
- Cucculelli, M. & Goffi, G. (2016). Does sustainability enhance tourism destination competitiveness? Evidence from Italian destinations of excellence. *Journal of Cleaner Production*, 111:370-382.
- Dzansi, Y. (2004). *Social responsibility of SMMEs in rural communities*. PhD thesis. Pretoria: University of Pretoria. [Online]. Available from: <http://upetd.up.ac.za/thesis/available/etd-03302005-112633/unrestricted/00front.pdf> [Accessed on: 12 May 2012].
- Farmakis, A., Altinay, L., Botterill, D. & Hilke, S. (2015). Politics and sustainable tourism: The case of Cyprus. *Tourism Management*, 47:178-190.
- Fatoki, O. (2014). Student entrepreneurs on university campus in South Africa: Motivations, challenges and entrepreneurial intention. *Mediterranean Journal of Social Sciences*, 5(16):100-107.
- Hair, J.F. Jr, Money, A.H., Samouel, P. & Page, M. (2007). *Research methods for business*. Chichester: Wiley.
- Haskins, C. (2009). *Using the concept of sustainable development to encourage corporate responsibility in small enterprises*. Europa Conference, Brussels. [Online]. Available from: http://ec.europa.eu/research/sd/conference/2009/papers/3/cecilia_haskins__corporate_responsibility.pdf [Accessed on: 12 July 2010].
- Hong Kong University Engineering Alumni Association (HKUEAA). (2007). Sustainable development study tour to Singapore. [Online]. Available from: <http://www.ies.org.sg/publication/enewsletter/Writeup2Jun10.pdf> [Accessed on: 12 May 2012].
- Jarvis, N., Weeden, C. & Simcock, N. (2010). The benefits and challenges of sustainable tourism certification: A case study of the Green Tourism Business Scheme in the West of England. *Journal of Hospitality and Tourism Management*, 17(01):83-93.
- Jones, G. (2013). SMMEs in dire straits. *Financial Mail*. [Online]. Available: <http://www.financialmail.co.za/fm/CoverStory/2013/06/13/smmes-in-dire-straits>. [Accessed on: 9 Oct. 2015].
- Lamb, C.W. Jr, Hair, J.F. Jr, McDaniel, C., Boshoff, C., Terblanche, N., Elliot, R. & Klopper, H.B. (2010). *Marketing*. 4th ed. Cape Town: Oxford University Press.
- Metz, B., Davidson, O.R., Bosch, P.R., Dave, R. & Meyer, L.A. (eds). (2007a) Climate change 2007: Working group III: Mitigation of climate change. Cambridge: Cambridge University Press. [Online]. Available from: http://www.ipcc.ch/publications_and_data/ar4/wg3/en/ch12s12-es.html [Accessed on: 25 Jan. 2012].
- Pérez, A. & del Bosque, I.R. (2014). Sustainable development and stakeholder relations management: Exploring sustainability reporting in the hospitality industry from a SD-SRM approach. *International Journal of Hospitality Management*, 42:174-187.

- Prugh, T., Costanza, R. & Daly, H.E. (2000). *The local politics of global sustainability*. Washington, DC: Island Press.
- Revell, A., Stokes, D. & Chen, H. (2010). Small businesses and the environment: Turning over a new leaf? *Business Strategy and the Environment*, 19:273-288.
- Rogerson, C.M. (2005). Unpacking tourism SMEs in South Africa: Structure, support needs and policy response. *Development Southern Africa*, 22(5):623-642.
- Rogerson, C.M. (2007). Backpacker tourism in South Africa: Challenges and strategic opportunities. *South African Geographical Journal*, 89:161-171.
- Schoof, U (2006). *Stimulating Youth Entrepreneurship: Barriers and Incentives to Enterprise Start-ups by Young People*, Series on Youth and Entrepreneurship. International Labour Organization, (76), 1-12.
- Seidel, M., Seidel, R., Tedford, D., Cross, R., Wait, L. & Hämmerle, E. (2009). Overcoming barriers to implementing environmentally benign manufacturing practices: Strategic tools for SMEs, *Environmental Quality Management*, 18(3):37-55.
- Shi, H., Peng, S.Z., Liu, Y. & Zhong, P. (2008). Barriers to the implementation of cleaner production in Chinese SMEs: government, industry and expert stakeholders' perspectives. *Journal of Cleaner Production*, 16(7):842-852.
- Turton, N. & Herrington, M. (2012). Global Entrepreneurship Report Monitor (GEM) South African Report.
- Walker, E., Wang, C. & Redmond, J. (2008). Women and work-life balance: Is home-based business ownership the solution? *Equal Opportunities International*, 27(3):258-275.
- Yasarata, M., Altinay, L., Burns, P. & Okumus, F. (2010). Politics and sustainable tourism development—Can they co-exist? Voices from North Cyprus. *Tourism Management*, 31(3):345-356.

EMBEDDING THE CONVENIENCE STORE BUSINESS IN A CHANGING CHINESE MARKET: A CASE STUDY OF FAMILYMART

Sulin Chung
Tokyo Institute of Technology, Japan

ABSTRACT

This paper applies the embeddedness concept identified by Hess (2004) and the ‘Convenience Business Model (CBM)’ framework to demonstrate how FamilyMart China embedded itself in the Chinese market in two stages. This was achieved through a combination of societal, network, and territorial embeddedness. We discover that FamilyMart China transferred the basic CBM concept during the entry stage, and focused mainly on its ‘background system’ by entering into joint ventures. This embeddedness was primarily network-related. In FamilyMart China’s growth and development stage, the focus shifted towards the CBM ‘front system’ to create value for its customers and its embeddedness was primarily territorial.

Keywords: convenience store; retail internationalization; embeddedness; Chinese market; FamilyMart.

INTRODUCTION

The grocery retail market in China will be worth US\$ 1.450 billion by 2021 (IGD Retail Analysis, 2016). Convenience stores (c-stores) are a high growth business in the Asia-Pacific region (Planet Retail, 2017). However, the stores of the three largest local c-store companies in Shanghai had negative growth rates in 2015. In contrast, three Japanese c-store businesses had high growth rates. FamilyMart (1,501 stores) grew at 17.2%, Lawson (652 stores) had a growth rate of 28.3%, and 7-Eleven (192 stores) recorded a 12.9% growth rate (CCFA, 2016). FamilyMart is one of three Japanese c-store firms that have made profits in China since 2014.

The FamilyMart brand is owned by FamilyMart UNY, created after the merger of FamilyMart with the UNY Group in September 2016, making it the second-largest c-store chain in Japan. At the end of January 2017, FamilyMart UNY had 24,434 stores, including 18,100 stores in Japan and 6,334 stores in the rest of Asia. FamilyMart’s Chinese subsidiary is the third-largest in terms of number of stores, after its Japanese and Taiwanese networks.

How does a Japanese c-store business embed itself in such an extremely competitive and changing market as China? Do any challenges exist for the international c-store business in maintaining its growth in this market?

This paper applies the embeddedness concept proposed by Hess (2004). An analysis of the elements of the ‘Convenience Business Model (CBM)’ provides an understanding of each CBM element: where, when, and how it will be embedded. Finally, we will discuss c-store growth issues in a challenging Chinese market.

The historical data used in this paper was generated through in-depth interviews with company executives in China in 2007 and 2016, and in Japan in 2015 and 2016. Company documentation, public websites, and third-party commentaries were also referred.

THEORETICAL FOUNDATIONS

For Hess (2004), embeddedness is a spatiotemporal concept and differs from other embeddedness studies by providing societal, network, and territorial forms of embeddedness. ‘Societal embeddedness: Signifies the importance of where an actor comes from, considering the societal (i.e., cultural, political, etc.) background’, ‘Network embeddedness: Describes the network of actors a person or organization is involved in’, and ‘Territorial embeddedness: Considers the extent to which an actor is ‘anchored’ in particular territories or places’ (pp.176–177).

According to Hess (2004), “Globalisation is a process of transnational network building or embedding, creating and maintaining personal relationships of trust at various, interrelated geographical scales” (p. 176). He also mentions, “If actors engage in global production networks, they carry the ‘genetic code’ with them when going abroad” (p. 180).

Current research applying Hess’ (2004) embeddedness concept to an analysis of retail internationalization can be divided into two groups. The first group links Hess’ (2004) embeddedness to Dicken’s (2000) distinction between ‘Placing Firms’ and ‘Firming Places’ for the analysis of retail internationalization. The second group illustrates the embeddedness process of the international retailers through the retail business model.

The first group consists of geographers. They focus mainly on the aspect of territorial embeddedness. For instance, Wrigley, Coe, and Currah (2005, p. 437) explain “how it is the necessarily high territorial embeddedness in markets and cultures of consumption, planning and property systems, and logistical and supply chain operations that defines the distinctive theoretical and organisation challenge of the retail transnational corporation (TNC)”. Additionally, they use Dicken’s (2000) distinction between ‘Placing Firms’ and ‘Firming Places’ to explore the relationship with Hess’ (2004) embeddedness concepts. In the ‘Placing Firms’ question, ‘Where firms come from is important’ (Dicken 2000, pp. 277–282) and the key here is to explore the dialectical relationship between Hess’ notions of societal embeddedness and territorial embeddedness. The ‘Firming Places’ question ‘How TNCs use space and place’ (Dicken 2000, pp. 282–287) relates directly to Hess’ notions of network embeddedness. Following this thematic structure, Coe and Lee (2006, 2013) mobilizes the notions of territorial embeddedness and strategic localization of Samsung–Tesco in South Korea. Wood, Coe, and Wrigley (2016) explore how Tesco has addressed the multi-scalar aspects of localization and capability transference across its Asian operations.

On the other hand, Burt, Johansson, and Dawson (2016) focus on the internationalization of IKEA and explicate how the concept of embeddedness can provide a better understanding of the process of retailer internationalization via a consideration of the components of the retail business model by Osterwalder and Pigneur (2010) (pp. 715–747). However, each of food grocery, fashion, and electronics has a different retail business model (Dawson, 2015; Burt, Davies, Dawson, & Sparks, 2008; Burt et al., 2016). For the retail type of c-store focused on food and grocery items, this paper makes use of the c-store business model (CBM) proposed in Chung (2016).

Why do we need to apply the embeddedness concept when investigating the process of internationalization of FamilyMart in China? Viewing embeddedness as a ‘temporal’ concept, as stated in Burt et al. (2016), the concept of embeddedness can be used to develop a framework for gaining a better understanding of the activity of retailers when they enter and subsequently develop in a foreign market (p.720). By considering embeddedness as a ‘spatial’ concept, we can first examine the interactions across subsidiaries and local market contexts (Meyer, Mudambi, & Narula, 2011) and then the “two-way knowledge flow between the home market and subsidiaries, and between subsidiaries themselves” (Wood, Coe & Wrigley, 2016).

Applying the Embeddedness Concept to Explain the Transfer of the ‘Convenience Business Model (CBM)’ to Overseas Markets

Building on the earlier studies, this paper summarizes the analysis of retail internationalization and embeddedness; further, it recommends that it should be investigated from both the ‘temporal’ and ‘spatial’ angle. From the ‘spatial’ angle, retail internationalization can be seen as transferring and embedding the results of innovation from the originating in the home country to the host market in which the retailer operates. When innovation occurs in the host market in which the retail company operates, it will probably influence the strategies of the home office and others in the host market (see Figure 1).

Figure 1: Embeddedness between the home country and the host markets

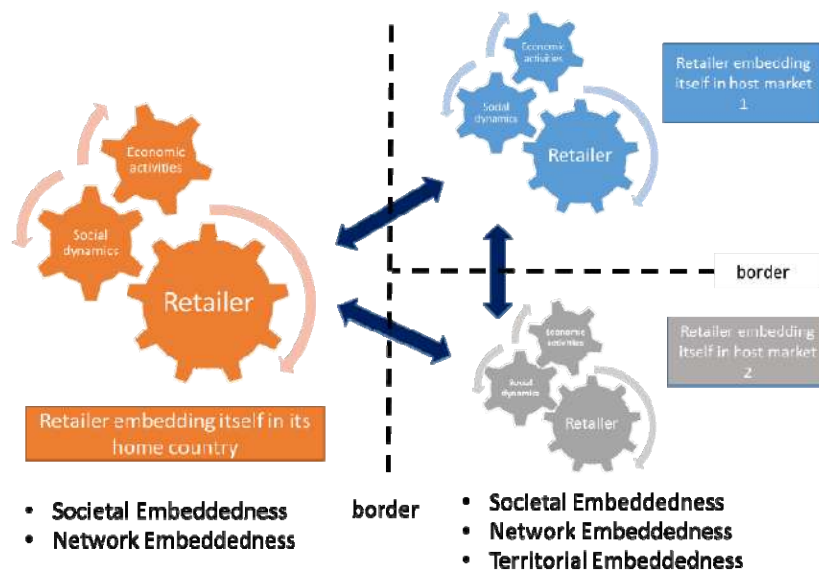

Source: Summary by the author

From the ‘temporal’ angle, the retail internationalization process can be seen as consisting of different stages such as pre-entry, entry, growth and development, and withdrawal. The timing, content, and outcome of the retail business system’s embeddedness in the host markets are different.

Considering embeddedness as a ‘temporal’ concept, we investigate the embedding process through two stages: entry and growth and development. As embeddedness is also a ‘spatial’ concept, we study the interaction between the firm and the Chinese market. This paper will also apply the embeddedness concept to explain the transfer of the CBM to the Chinese market.

Chung’s (2016) CBM consists of nine elements in three categories: (1) The front system: a retail-based combination of the service, quality and cleanliness, and franchise chain store development strategies. (2) Store operations: The supervisor, franchise accounting, and human resources education systems. (3) Background system: The merchandise-sourcing (such as ready-to-eat food facilities), merchandise supply, and distribution and information systems.

EMBEDDEDNESS IN THE ENTRY STAGE (2004 to 2010): EMBEDDING THE BASIC ‘CBM’ CONCEPT

FamilyMart operates in China under China CVS Holding Corporation, which was established in Shanghai in 2004 as a joint venture of Japan FamilyMart, Taiwan FamilyMart and the Ting Hsin Group, their local partner. The Ting Hsin Group is a Taiwanese capital corporate group that owns the famous ‘Master Kong’ instant noodles and drinks brand, as well as fast-food restaurants in China.

The analysis revealed six important points of action for ensuring FamilyMart’s embeddedness during the entry stage: (1) FamilyMart transferred their basic CBM concept through their subsidiary, Taiwan FamilyMart. Taiwan and China have a similar culture and language, and Taiwan FamilyMart had a successful development experience in Taiwan. (2) FamilyMart embedded itself into the local network through its local partner, Ting Hsin Group, which invested in an information system and distribution center, catering exclusively to FamilyMart China. (3) FamilyMart localized their product assortment, and especially in the ready-to-eat food category. Although tobacco generates high sales in c-stores in Japan, foreign companies cannot sell it in China. Therefore, ready-to-eat foods are becoming crucial for the sales of these stores. (4) FamilyMart practised territorial embeddedness by expanding their business into different locations and areas. For example, the subway station proved an important target location. In 2007, FamilyMart also expanded its business into other cities such as Guangzhou and Suzhou. (5) FamilyMart discovered a solution to barriers in extending their franchise business, as individuals do not own land or stores in China. The company solved this problem by preparing stores for their franchisees, and introduced special discount programs to incentivize their employees to own its franchise stores. (6) FamilyMart also developed a three-stage training program for their Chinese employees, who would receive certifications from FamilyMart on completing their program(s).

Overall, embeddedness in the entry stage focuses on network embeddedness, by building an infrastructure of background systems and transferring the basic CBM concept. FamilyMart opened their 500th store in China at the end of 2010, and became profitable in the third quarter of the same year.

EMBEDDEDNESS IN THE GROWTH AND DEVELOPMENT STAGE (2011 TO PRESENT): TURNING THE MANAGEMENT CRISIS INTO A GROWTH OPPORTUNITY

FamilyMart China experienced high-speed store expansion in 2011 and 2012, reaching 800 stores by the end of 2012. However, the firm also recorded a 500 million yen loss in that year due to increase in store rentals, soaring labour costs, and operational issues caused by the company’s expansion strategy during 2010–12.

Facing a crisis in its loss of management control, FamilyMart China set two strategic goals in late 2012. They first aimed to generate a profit from each store, while the second goal involved an increase in the number of franchise stores. Six actions were used to reach these goals: (1) The store development strategy was revised by closing unprofitable stores, establishing higher profit goals for the new stores developed, and introducing eat-in corners in their stores. The firm found these steps to be crucial in increasing sales. (2) Ready-to-eat food categories were reinforced. The CEO of FamilyMart China, who is from the local partner, is highly committed to discovering local gourmet foods suitable for in-store sales. (3) The ratio of franchise stores was increased by encouraging employees’ ownership of franchise store(s). With the exception of strategies initiated in the aforementioned late-entry stage, the entrepreneurship of individuals from rural areas powered the firm’s franchise business. (4) The company introduced new member’s cards and designed new promotional methods for the Chinese market to improve its relationship with local customers. The new member’s card is common to Ting Hsin Group’s retail and restaurant businesses. This card also has an app version; members can make purchases online with discount prices through a special website. (5) The company cooperated with other companies to improve services, simultaneously reinforcing their networks. For instance, customers could click and collect products from Tmall, which is a

subsidiary of, the Alibaba Group. (6) The company extended its business and gradually established subsidiaries in other cities.

The CBM transfer primarily focuses on the ‘front system’ in the growth and development stage. The firms created value for their customers and links to profit and growth after 2014 through this territorial embeddedness.

The challenges for FamilyMart China could remain issues in deepening their embeddedness. As Hess (2004, p.177) notes, ‘Economic actors become embedded there in the sense that they absorb, and in some cases become constrained by, the economic activities and social dynamics that already exist in those places’. For instance, the firm must have a socially responsible culture to deepen the societal embeddedness. This is also another key factor for c-stores’ recent growth in Japan.

CONCLUSION

This paper demonstrated how FamilyMart China embedded itself in the Chinese market in two stages. This was achieved through a combination of societal, network and territorial embeddedness. We discovered that FamilyMart China transferred the basic CBM concept to its Chinese subsidiary during the entry stage, and focused on its background system by entering into joint ventures. This embeddedness was primarily network-related.

In FamilyMart China’s growth and development stage, the focus shifted to the CBM ‘front system’ to create value for their customers, and its embeddedness was primarily territorial. Innovation and business transformation in late 2012 resulted in the firm generating an annual profit from 2014 onwards. Thus, we can conclude that gradual but continuous progress in its embeddedness makes FamilyMart China boost its growth in a changing Chinese market.

This paper has the following academic implications. First, this paper proposes and illustrates both the temporal and spatial aspects of the concept of embeddedness. Despite embeddedness being a spatiotemporal concept in Hess (2004), the current literature on retail internationalization focuses mainly on Hess’ (2004) ‘spatial’ angle. Second, this paper demonstrated how FamilyMart China embedded itself in the Chinese market in two stages, as well as the connection between the embedding strategy and the CBS model. This paper has implications for companies aiming at sustainable growth overseas as it suggests that companies should introduce internal and external embeddedness during different stages of their internationalization.

Further research is required to examine the impact of FamilyMart’s overseas subsidiaries on its central office in Japan. How retail embeddedness influences the retail industry formation in different countries also needs to be investigated.

REFERENCES

- Burt, S.; Davies, K., Dawson, J., & Sparks, L (2008), Categorizing patterns and processes in retail grocery internationalization, *Journal of Retailing and Consumer Services*, Vol.15(2), 78–92
- Burt, S., Johansson, U., & Dawson, J. (2016), International retailing as embedded business models, *Journal of Economic Geography*, Vol. 16(3),715–747.
- CCFA (2016), 100 Chain Stores in 2015, (<http://www.cdfa.org.cn/portal/cn/view.jsp?lt=31&id=425014>)
- Chung, S. (2016), ‘The Localization Process of FamilyMart in Thailand: the Relationship with the Formation of the Dynamic Capabilities’, *The Journal of Asian management studies*, Vol. 22, 59-77.
- Coe, N. M. & Lee, Y. S. (2006) , The Strategic Localization of Transnational Retailers: The Case of Samsung - Tesco in South Korea, *Economic Geography*, Vol.82 (1), 61–88.
- Coe, N. M. & Lee, Y. S. (2013), ‘We’ve learnt how to be local’: the deepening territorial embeddedness of Samsung–Tesco in South Korea, *Journal of Economic Geography*, 2013, Vol. 13(2), 327–356
- Dawson, J. A (2015), Retailers as agents in local economic and social revitalization: Applying the concept of embeddedness, *Book of Abstracts 29th Japan Society for Distributive Science Conference*, 22–28.
- Dicken, P. (2000) , Places and flows: Situating international investment. In Clark, G.L., Feldman, M. and Gertler, M.S., editors, *The Oxford Handbook of Economic Geography*, Oxford University Press, Oxford.
- Hess M. (2004), ‘Spatial’ relationships? Towards a reconceptualization of embeddedness, *Progress in Human Geography* 28, 165-186.
- IGD Retail Analysis (2016) (<https://retailanalysis.igd.com/>)
- Meyer, K.E., Mudambi, R., & Narula, R. (2011), Multinational enterprise and local contexts: the opportunities and challenges of multiple embeddedness, *Journal of Management Studies*, Vo.48(2), 235–252.
- Osterwalder & Pigneur (2010), *Business Model Generation: A Handbook for Visionaries, Game Changers, and Challengers*, Wiley.
- Planet Retail (2017) (<http://www1.planetretail.net/>)
- Wood S., Coe N & Wrigley N. (2016), Multi-Scalar Localization and Capability Transference: Exploring Embeddedness in the Asian Retail Expansion of Tesco, *Regional Studies*, Vol.50 (3), 475–495.
- Wrigley, N., Coe, N.M., & Currah, A.D. (2005) , Globalizing retail: conceptualizing the distribution-based transnational corporation (TNC), *Progress in Human Geography*, Vol.29 (4), 437–457.

CHINESE MIGRATION TO AUSTRALIA: FROM DISCRIMINATION TO BUSINESS INVESTORS?

Mona Chung, Deakin University, Australia

Bruno Mascitelli, Swinburne University of Technology, Australia

ABSTRACT

This paper examines the phenomenon of Chinese migration into Australia. The history of Chinese migration goes back nearly as long as the colonial continent was established. The first major wave which brought a noticeable number of Chinese to Australia was the gold rush. Although Chinese were the first non-British migrant group they were discriminated. Under the 'White Australian Policy' it was guaranteed that the Chinese would not figure in any real way in the Australian population. However in the more recent years, more noticeably since 2005, benefited from the 'going abroad' policy by the Chinese government, investments from China started to flow inwards into Australia followed by the current bigger than ever migration move. Under the Business Innovation and Investment Programme (BIIP) 90% of the applications are Chinese. By 2010-2011 for the first time, the Chinese migrants became the largest migrant group in Australia. This change is significant as Australia has previous been dominated by English and European migrants prior to this point. From this point onwards, the composition of the population of Australia is headed for significant change (Armilli & Mascitelli (2016). The true motivations by the Australian (and other western) nations are questionable and can only send a message that "we may still not like you but we want your money". As a regional middle size power, the ability to portray concern for your regional neighbours in this way is not convincing. Were there not an economic gain from these visa arrangements, Australia would most probably treat China and Chinese migration as it did in the past – the cautious and suspicious way of distrust and lack of mutual respect. This still remains the fundamental divide between these two nations.

Keywords: migration, investments, Chinese, Chinese Australian history, economic migration.

INTRODUCTION

Australia from its outset was country of migration be it colonial or otherwise. The historic waves of migration have been in line with the formation and development of this country. Much of the early migration to Australia involved British colonial people movement both in the form of British, free settlers as well as convicts and petty criminals (Migration Heritage Centre 2017). Non-British settlement and migration on the other hand has however generally been a source of curiosity and even controversy.

Chinese settlement in Australia has evolved from being tightly controlled migration in the early times (enshrined through the Immigration Restriction Act of 1901), popularly known as the White Australian Policy, which effectively banned Asian migration for the next fifty years, through to more modern times whereby Chinese migration is amongst the top sources of migration to Australia. Highlighted by the last decade of strong economic engagement between China and Australia, the very relationship between these two nations have almost turned full circle. As Collins noted: "For most of its history Australia attempted to exclude Asians from Australian life, in the last decade Asia and Asians have played a greater role in Australian society that at any time in its history" (Collins 1996: 378). Today China is Australia's largest trading partner, has a strategic Free Trade Agreement and challenges the US for Asian regional security leadership. The purpose of this paper is to ascertain the changes in Australia's approach towards the Chinese and how these changes have gone from initially being discriminatory to a business

approach towards migration. In addition, this paper will seek to highlight the manner in which, different from the past, Chinese migrants have sought out Australia as a new destination and home from the 1990s until today.

A SHORT OVERVIEW OF CHINESE MIGRATION TO AUSTRALIA

Chinese migration to Australia is one of the oldest outside of British migration. Chinese migration to Australia goes back to two specific periods of Australia’s short history. The first period included the second half of the 19th century associated with the news of gold discoveries especially in Victoria and New South Wales. The second phase of this Chinese migration is in a more contemporary period, which emerged towards the end of the 20th century and into the new millennium.

The gold rush brought large numbers of Chinese to Australia in the 19th century. A large proportion of them settled around the goldfields in Victoria and New South Wales. For instance between 1851 and 1861 42,000 migrants came from China which was the third top from the list after British and Irish and continental Europe (Migration Heritage Centre 2017). In 1861, the Chinese population in Victoria made up 7 per cent of the total (Museum Victoria 2017) and reached 3.3 per cent of the total Australian population.

This large presence of Chinese would even out by the time of Federation in 1901 with Chinese making up a 1 per cent of the total population (Inglis 2006). While the Chinese were one of the first non-British migrants to make a mark on Australian demography, the 1901 Immigration Restriction Policy, known as White Australia, ensured that Chinese would not be welcomed to this new nation. Collins observed that White Australia was “the bedrock of the new Australian nation at federation in 1901, blocking entry for Asian and other ‘coloured’ people to Australia until the 1960s” (Collins 1995: 376). Moreover, White Australia also guaranteed that the Chinese would not figure in any real way in the Australian population (as can be seen from Table 1) until the end of the 20th century when the White Australia Policy dead and buried.

Table 1: The Chinese in Australia – 1901 -2011

Year	Chinese	Part Chinese	Total Chinese	% of Australian Population
1901	22,753	3,019	25,772	0.58
1921	17,157	3,669	20,826	0.39
1933	10,846	3,503	14,349	0.21
1947	9,144	2,950	12,094	0.16
1954	12,878	2,680	15,558	0.17
1961	20,382	3,186	23,568	0.22
1971	26,198	NA	26,198	0.21
1986	169,141	27,206	196,347	1.30
2001	NA	NA	556,560	2.97
2011	NA	NA	865,722	4.0

Source: Adapted from Inglis (2006) and Armillei & Mascitelli (2016)

The next wave of arrivals were ethnic Chinese refugees from Vietnam and Cambodia during the 1970s when the White Australia came to an end under the Whitlam government (1972-1975) and to further the point in January 1973, Australia recognised the existence of the People’s Republic of China which until then had been a no-go area diplomatically. Australian diplomat and China observer FitzGerald noted: “The great post-war of Australia’s attitude to Asia was its joining hands with America in the policy of non-recognition and containment of China” (Fitzgerald 1997: 3). Equally important, under the proceeding government of Malcolm Fraser, it was” decided for the first time in Australia’s history to accept large numbers of Asian immigrants for permanent settlers” (Sheridan

1995: 7). These were ground breaking decisions especially in relation to Chinese immigration to Australia which would contribute, to the modern Australia of today.

Greater levels of economic migration from China started in the 1980s and 1990s and did so mostly from Hong Kong during the transition and return of Hong Kong to the mainland in 1997. These groups of Chinese migrants engaged in a reversal of the traditional migration pattern of settlement and instead had families settling in Sydney while the breadwinner returned to Hong Kong to continue earning the breadwinner income. The next phase of Chinese migration occurred from mainland China after the Tiananmen incident, with the then Australian Prime Minister, Bob Hawke allowing students from mainland China to settle in Australia permanently. Since then, immigrants from mainland China and Taiwan have arrived in increasing numbers. The biggest wave of mainland Chinese migration is the current one that took on numbers that are more meaningful from 2005 and reinforced with the introduction of the business innovation visas established in 2012. More will be discussed on this later in the paper.

THE NEW PHASE OF CHINESE MIGRATION TO AUSTRALIA

While European migrants represented the main driver of Australian population growth and diversity until the 1980's, the 1990's signaled an inversion of this trend with Vietnam, China and the Philippines entering the list of top 10 source countries (Phillips, Klapdor & Simon-Davies 2010). The impending absorption of Hong Kong in 1997 also contributed to higher numbers of Chinese seeking to find new host countries of which Australia was one (Jupp 1998). The initial pronouncement for an *open door* in 1979 by Deng Xiaoping and three decades later in 2009, by the Chinese government of *going global*, allowed many Chinese nationals with the benediction of the Chinese government to both invest and migrate overseas as they had never done before (Chung & Mascitelli 2015).

Australia was a major beneficiary of the new outward looking Chinese nation and this included in the area of migration but also investments made by the Chinese. Many countries such as America, Canada the UK saw the opportunities of attracting Chinese investments for their own economic development. This would be strongly felt in other European nations where the remnants of the global financial crisis was still being felt and they continued to suffer from being cash stripped such as Spain (Chung 2016). Australia however took it to a new level in 2004 and while it was consolidating its economic relationship with China, introduced a range of subclasses of visas for China under the Business innovation and investment category (DIBP 2016a). The intention here was to attract Chinese migrants who had the financial means to first invest and then migrate to Australia. Even newer and more ambitious visa subclasses were introduced in 2012-13 by Australian authorities, such as the 188 and 888 visas. Although these visas were open to all nationalities, they were clearly designed for the Chinese market given that number 8 is known as a lucky number to the Chinese.

The subclass 888 visa is by far the highest investment commitment in the world in dollar terms for any potential migrant. The two pre-condition subclasses before the 888 to satisfy the conditions are the subclass 188 and 444. Under the 188, there are five streams with each stipulating the requirement of investment amounts for the applicant in order to qualify. The premium investor stream requires \$A15 million to be injected into the Australian economy (DIBP 2016b) and to qualify for Australian residency.

The current wave of Chinese migration however has a fundamentally different connotation. This time it is built on the basis of economic attraction, a kind of different form of "goldfields". Much of this is built around a combination of investment and alongside migration to Australia. In 2006, the Chinese replaced Italians as the major source of overseas-born population. The desire of Chinese to come to Australia is strong and is channeled through the combination of financial contributions alongside the migration component.

ECONOMIC MIGRANTS: THE CHINESE IN AUSTRALIA

Canada lead the way, throughout the 1990s, in continuing to attract migrants from across all continents. It was a period when migration was becoming more restrictive and in Australia with the Howard government, partially in response to the Pauline Hanson anti-Asian sentiments, tightened up immigration numbers (Jupp 1998). Canada was the first nation to mould the visa system to attract business and economic migrants from countries such as China (Ley 2010) at the time of the handover of Hong Kong to China. This handover created much uncertainty among the Hong Kong Chinese who had little political confidence in the Chinese government in terms of the guarantee of their economic and political freedoms. This saw the phenomena of growth in the real estate sector in cities such as Toronto and Vancouver (Ley & Tutchener, 2001). Australia eventually learnt the ropes and began themselves introducing visa schemes allowing for access to Australia with economic strings attached. The real estate sector boom in the past two decades is one example of the success of this economic effect (Chung & Mascitelli 2016).

For Chinese the Skilled Independent visas constitute the larger proportion of the Migration Program in the period between 2001 and 2015 with 29.8 per cent and 37.8 per cent respectively. This visa category is followed by the Partner visa category with 20.6 per cent for China and 24 per cent for Hong Kong. While for Chinese nationals, the third largest group is made up of those applying for a Business Innovation and Investment visa (15.7 per cent), the Skilled Regional visa represents the third most common option for people from Hong Kong. As for the other Asian countries under examination, the largest group of Taiwanese nationals (4,384 or 31.2 per cent) applied for permanent residence through the Partner category. This is followed by the Business Innovation and Investment (24.1 per cent) and the Skilled Independent (20.5 per cent) visas. Overall, in the three cases the Skill Stream constitutes over 60 per cent of the entire Migration Program.

THE AUSTRALIAN MIGRATION PROGRAM

Australia is a nation of migrants. Its population growth is dependent upon migration rather than natural population growth. Without migration, Australia will be threatened with population decline and most certainly with economic difficulties.

Table 2: Migration Program: Top ten source countries of migrants from 2004–05 to 2014–15

Countries of migrant	2004-05	2006-07	2008-09	2010-11	2012-13	2014-15	2014-15 as a % of Total	Total 2004-15	% of Total 2004-15
India	11,822	19,505	25,042	21,768	40,051	34,874	18.4%	284,246	15.5%
China	13,880	20,729	21,831	29,547	27,334	27,872	14.7%	257,012	14.0%
UK	25,942	31,401	30,590	23,931	21,711	21,078	11.1%	290,463	15.8%
Philippines	4,571	6,280	9,001	10,825	10,639	11,886	6.3%	99,272	5.4%
Pakistan	1,556	1,688	2,051	2,059	3,552	8,281	4.4%	34,676	1.9%
Ireland	1,585	1,850	2,500	3,700	5,209	6,187	3.3%	38,942	2.1%
Vietnam	2,372	3,478	3,285	4,709	5,339	5,100	2.7%	43,941	2.4%
South Africa	4,746	5,284	11,729	8,612	5,476	4,284	2.3%	76,022	4.1%
Nepal	532	713	968	2,060	4,103	4,130	2.2%	22,110	1.2%
Malaysia	4,491	4,654	5,029	5,130	5,151	3,977	2.1%	52,854	2.9%
Total	120,064	148,200	171,318	168,685	190,000	189,097		1,832,548	100%

Source: Armillei & Mascitelli (2016)

As discussed earlier, the historical major source of migrants have traditionally been from the UK and Ireland. Table 2 above shows consistently that British migration has been the number one group until 2008-2009. What is equally important to note is that the number of Chinese migrants has grown by 36 per cent in 2008-2009 from 2004-2005 while the British migrants only grew by 15 per cent in the same period. By 2010-2011 for the first time, the Chinese migrants became the largest migrant group in Australia. This change is significant as Australia has previous been dominated by English and European migrants prior to this point. From this point onwards, the composition of the population of Australia is headed for significant change (Armilli & Mascitelli (2016).

THE BUSINESS INNOVATION AND INVESTMENT PROGRAMME

As a nation of small population, not only our population growth is depended upon on migrants, the growth of the nation's economy is also depended on foreign investments. One of the major sources of foreign investments is the new business innovation and investment programme. This is a new form of migration with investments.

The business innovation and investment programme (BIIP), in particular, was introduced on 1 July 2012 (after a comprehensive review of the existing business skills programme) in order to allow migrants to establish new businesses or invest in Australia (Department of Immigration and Border Protection [DIBP] 2014). There are 3 subclasses in the BIIP.

1. The business Talent visa (subclass 132) permits immediate permanent residency. It is intended to facilitate immigration by people who have a significant history in business and by migrant entrepreneurs.
2. The Business Innovation and Investment (Provisional) visa (subclass 188) is a temporary visa for people who want to own or manage a new or existing business in Australia, or invest in Australia. 188 is granted to eligible migrants who wish to establish a business or invest in Australia for a four-year period. Eligibility of migrants is based on a points test which consider age, English-language ability, personal wealth, business and investment activity, and innovation metrics. According to the *Annual Report 2013-14* released by the DIBP (2014: 54), 'China continues to be the key source country under the SIV programme¹, making up 90.5 per cent of the programme to date'. Since 2010 the visa '132' and '188' have been growing exponentially for China and Chinese visa requests.
3. The Business Innovation and Investment (permanent) visa (subclass 888) is a permanent visa for people who own or manage a business in Australia, or invest in Australia. Applicants must first be granted a provisional visa, and can be eligible for a permanent visa after a given period. There five 'streams' which determine the length of the period:
 - a. Business innovation extension stream
 - b. Investor of minimum 1.5 million
 - c. Significant investor (at least \$5 million in complying investments)
 - d. Significant investor extension stream
 - e. Premium investor (at least 15 million)

The Premium Investor Visa offers permanent residency to investors willing to invest a minimum amount of A\$15 million in the local economy. In return, investors will be able to apply for the residency status after 12 months, the speediest route to Australian residency so far. BIIP is particularly popular for the new Chinese migrants that about 70 per cent of the intake in the recent years are Chinese from mainland while in the SIV stream 90 per cent are from China (Productivity Commission 2016).

¹ Significant Investor visa (SIV) is a stream within the BII programme.

In the history of Chinese migration into Australia, BIIP is the most significant program in attracting Chinese into Australia. However according to the Productivity Commission, the true extends of the program is still too early to tell possible as early as 2023. The current controversial question is whether the design of the program will have a negative or positive outcome when weighting economic benefit in the short-term versus lifetime costs of social security, health and aged care and this should also include the associated secondary applicants (Productivity Commission 2016). In other areas such as job creation, according to the data collected by Western Australian Business Migration Centre (2014) for the 2013-2014 financial year the injection of new capital into the State's economy was estimated to exceed \$275 million and generated over 300 new jobs. However, in percentage terms 300 jobs only represent 0.02 per cent which is relatively insignificant.

The approach is not a new one and other countries such as Canada, New Zealand and United States also have similar policies. The migrant investment category of New Zealand is very similar to the BIIP program though it is less onerous in investment levels than that of Australia. However, the Canadian government in June 2014 has cancelled its investment visa programs (Australian Productivity Commission Report 2016).

TEMPORARY CHINESE MIGRANTS TO AUSTRALIA

Chinese visitors to Australia on a temporary base has increase dramatically in the recent years. Chinese tourists have become the largest group visiting Australia. Table 3 demonstrates that since 2014-2015, the Chinese have overtaken the English, to become the largest group of visitors.

Table 3: Visitor visas Offshore Visitor visas granted—top 10 source countries from 2004-05 to 2014-15 (to 30 June)

Citizenship Country	2004-05	2006-07	2008-09	2010-11	2012-13	2014-15	2014-15 as a % of Total	Total 2004-15	% of Total 2004-15
China	195,912	239,061	231,953	323,007	473,206	661,943	15.3%	3,779,991	9.4%
UK	655,271	674,771	587,072	570,561	543,495	557,918	12.9%	6,530,978	16.2%
USA	385,827	385,384	370,866	373,051	380,086	426,950	9.9%	4,266,458	10.6%
Japan	642,994	556,453	351,307	324,215	300,899	295,531	6.9%	4,472,871	11.1%
Malaysia	138,688	126,030	160,019	192,157	214,817	292,280	6.8%	2,003,525	5.0%
Singapore	148,502	128,422	131,309	141,684	169,812	203,300	5.3%	1,641,103	4.1%
S. Korea	223,002	235,186	150,619	175,502	161,317	185,083	4.3%	2,037,990	5.1%
India	56,308	75,116	90,569	106,116	130,497	175,402	4.1%	1,154,925	2.9%
Germany	136,407	138,230	136,616	142,133	139,386	151,168	3.5%	1,551,855	3.8%
France	93,982	101,505	116,328	122,872	113,317	131,544	3.1%	1,256,351	3.1%
Total	3,594,763	3,652,215	3,355,311	3,518,588	3,728,879	4,311,498²		40,296,884	

Source: Armillei & Mascitelli (2016)

Temporary visas do not permit visitors to stay longer than their visa permitted period however there are a range of skilled and/or work related temporary working visas which do allow migrants in this category to stay eventually. The subclass 457 (temporary work skilled visa) and subclass 402 (training and research visa) both might lead to permanent visas condition to the consolidated sponsored occupations list (Australian Productivity Commission Report 2016).

² It includes visitor visa grants where the client was outside or in Australia. In previous annual reports, tables on visitor visa grants generally only included clients outside Australia.

When it comes to Temporary work (skilled) visa (subclass 457) granted (Table 3), China ranked third for 2014-15, with an increase of 8 per cent in the number of visas granted compared to the previous financial year, well behind India and UK. This does not reflect its position in absolute terms. With 5.3 per cent (or 54,027) of all '457' granted in the period 2004-15, China occupies the fifth position, also behind USA and Philippines. India has been the major contributor to this visa program over the last three years in a row. South Asian countries have displaced the UK as the largest source. In more global terms, though, India is behind the UK when considering the overall contribution as a percentage of all visas granted (17.6 per cent for India and 21.0 per cent for the UK) over the last decade. As for Hong Kong and Taiwan, their share was a very small 0.3 per cent and 0.2 per cent respectively of the total of the Australian '457' visa program issuance between 2004 and 2015. The design of 457 visa is not especially aimed at attracting Chinese workers or investments to solve labour shortage issues in Australia. It is an interesting contrast that the Chinese top the list of the BIIP, but not 457 visas. Nonetheless the total figures suggest some other possible interpretations: First there are enough Chinese who are interested in coming to Australia and secondly the new generation of the Chinese migrants are no longer here looking for opportunities to make money. Especially with the large numbers and rapid growth figures of the BIIP, Chinese clearly are leaving their country for other reasons.

Table 4: Temporary work (skilled) visas (subclass 457) granted — top 10 source countries, 2004–05 to 2014–15 (to 30/06)

Citizenship Country	2004-05	2006-07	2008-09	2010-11	2012-13	2014-15	2014-15 as % of Total	Total 2004-15	% Total 2004-15
India	4,921	11,964	14,770	15,808	27,211	25,240	26.3%	180,308	17.6%
UK	13,040	18,888	21,040	21,667	24,147	14,730	15.3%	215,125	21.0%
China	2,033	5,545	4,970	2,979	6,609	6,650	6.9%	54,027	5.3%
USA	2,924	4,768	5,560	7,020	7,063	5,460	5.7%	62,417	6.1%
Philippines	1,112	6,867	9,790	5,898	8,000	5,080	5.3%	69,115	6.7%
Ireland	1,770	2,119	3,130	5,817	10,291	4,120	4.3%	51,659	5.0%
France	960	1,584	1,920	2,089	2,421	2,390	2.5%	21,064	2.1%
Italy	360	661	853	918	1,706	2,110	2.2%	11,681	1.1%
South Korea	991	1,317	1,105	1,118	2,816	2,020	2.1%	17,239	1.7%
Canada	1,354	2,212	2,440	2,731	2,668	2,000	2.1%	25,821	2.5%
Hong Kong	205	198	154	185	372	452	0.5%	2,710	0.3%
Taiwan	113	200	190	206	391	417	0.4%	2,612	0.2%
Total	48,593	87,313	101,280	90,119	126,348	96,084		1,023,077	

Source: Armillei & Mascitelli (2016)

CHINESE STUDENTS IN AUSTRALIA

Over the past decade, Chinese students have been enrolling in Australian universities and Vocational Educating and Training (VET) institutions in numbers never seen before in educational history. The educational visa system represents the second most popular way to gain temporary residence in Australia, particularly for people coming from Asian countries. It is known that Australia is not necessarily China's favoured western educational destination. That role belongs to the US, but with a new US President in power, and not an especially friendly one to China, Chinese students are looking elsewhere to send their children and seek out qualifications in western universities. China, India and South Korea are the three major source countries forming together almost 40 per cent of the 2,821,181 student visas granted in the past decade as can be seen from Table 3. Hong Kong and Taiwan are well behind with 2.1 per cent and 1.6 per cent respectively. The '573 Higher Education Sector' is the Student visa subclass with the highest number of visa grants since 2004 for the three Asian countries under analysis. This is particularly evident for China and Hong Kong where this visa type has over sixty per cent of all preferences (75.2 per cent and 64.8 per cent respectively). Well behind we find the '572 Vocational Education and Training' with 10.6 per cent and 16.7 per cent of all Student visa grants. Taiwan registered a different use of the Student visa. The '573' visa has still the highest number with 39.2 per cent, but the '570 Independent ELICOS Sector' and '572' subclasses are not too far behind with 27.9 per cent and 23.2 per cent respectively.

Table 5: Top 10 source countries for student visas granted from 2004–05 to 2014–15 (30 June)

Citizenship Country	2004-05	2006-07	2008-09	2010-11	2012-13	2014-15	2014-15 as a % of Total	Total 2004-15	% of Total 2004-15
China	32,902	41,122	55,331	49,852	54,015	65,737	21.9%	545,390	19.3%
India	13,545	34,525	65,516	28,954	24,808	29,573	9.9%	362,617	12.8%
South	14,823	18,680	17,351	13,238	12,942	13,229	4.4%	168,210	6.0%
Brazil	4,537	8,289	12,525	9,780	10,682	13,034	4.3%	109,879	3.9%
Thailand	8,203	9,615	13,489	9,273	9,274	11,686	3.9%	113,682	4.0%
Malaysia	8,750	9,519	11,545	9,709	9,143	10,414	3.5%	107,831	3.8%
Vietnam	2,122	3,873	9,249	7,131	10,725	10,283	3.4%	82,145	2.9%
Indonesia	7,555	7,639	8,681	8,088	8,060	9,178	3.1%	90,794	3.2%
Nepal	658	4,990	13,995	8,830	7,112	8,987	3%	79,504	2.8%
Saudi	1,029	3,139	7,629	7,798	8,084	8,739	2.9%	68,213	2.4%
Hong Kong	6,750	5,841	5,747	5,240	4,678	5,985	2.0%	60,762	2.1%
Taiwan	3,725 ³	4,615	4,207	3,181	3,544	5,915	2.0%	45,910	1.6%
Total	175,818	230,807	319,632	250,438	259,278	299,540		2,821,181	

Source: Armillei & Mascitelli (2016)

CONCLUSION

This paper traced the changing Australian approach towards Chinese and Chinese immigration to Australia. What started as a very negative approach, substantially shunning Chinese settlement in Australia, has in the new millennium been one of accommodating but doing so in primarily business terms. The relationship with China and its people has less the quality of people to people cultural understanding but a money relationship. The business investment schemes, not exclusive to Australia projects an image of “we prefer your money” than your people but we can’t say no. There is little dispute that for Australia, this amalgam of significant investment visas program is another way to capitalise on China’s economic boom. To the extent that these programs can be viewed as being financially successful, they certainly project another image for the social impact of migration and a sustainable Australian community expressed in money rather than social terms. Simply put, the government offers a pathway to permanent residency in exchange for the outlay of funds into country. Analysis into these schemes indicates that Australia’s SIV program brought in around \$4 million a day for the Australian economy. Nine out of ten applications in the last financial year were from Chinese nationals. The Australian Productivity Commission (2016) in one of its findings suggested that ‘the economic benefits of the Significant and Premium Investor Visa Programmes are likely to be relatively modest and accrue mainly to the visa holders and to fund managers. Overall the case for retaining these visas is weak’. In many respects the Australian government is not heeding this advice.

The Australian government approach towards these financial incentive visa schemes for China has one eye on the Australian electorate and its racial sensitivities and one eye on the economic potential coming from these schemes. Moreover, Australia is also troubled by its close political proximity to the United States and the pressure it receives from this quarter. Long-term viability of these schemes is questionable. While short-term economic benefits cannot be questioned, nation building and social harmony certainly do not seem to be a consideration in these schemes. The true motivations by the Australian (and other western) nations are questionable and can only send a message that “we may still not like you but we want your money”. As a regional middle size power, the ability to portray concern for your regional neighbours in this way is not convincing. Were there not an economic gain from these visa arrangements, Australia would most probably treat China and Chinese migration as it did in the past – the cautious and suspicious way of distrust and lack of mutual respect. This still remains the fundamental divide between these two nations.

³ It includes only subclass 570 Independent ELICOS Sector visa, subclass 571 Schools Sector visa, subclass 573 Higher Education Sector visa.

REFERENCES

- Armilli R., & Mascitelli B., 2016, *From 2004 to 2016: A new Italian 'exodus' to Australia?* COMITES, Melbourne.
- Australian Productivity Commission Report 2016*, Australian Productivity Commission
- BMC (Business Migration Centre) 2014, *Submission: inquiry into the Business Innovation and investment Program (BIIP)*, Submission, 28 March, Western Australia
- Chung M., 2016, *The role of Chinese migration and investment in Europe*, Contemporary Issues in Business and Government, Vol 22, No 1
- Chung M. & Mascitelli B., 2015, *Dancing with the dragon: Doing business with China*, Business Expert Press, USA.
- Chung M. & Mascitelli B., 2016, *The Social Impact of Chinese Real Estate Investments in Melbourne*, Australia, Conference proceedings, GBATA 2016, Dubai
- Collins J., 1995, *Asian migration to Australia*, in Ed. R. Cohen *The Cambridge survey of world migration*, Cambridge University Press, Cambridge, UK.
- Department of Immigration and Boarder Protection, 2016a, *Overseas Arrivals and Departures*, <https://www.border.gov.au/overseas-arrivals-and-departures>, viewed 15 April 2017.
- Department of Immigration and Boarder Protection, 2016b, *Business Innovation and Investment Visa (subclass 188)*, retrieved 17/4/2017, <https://www.border.gov.au/Trav/Visa-1/188->, viewed 15 April 2017.
- FitzGerald S., 1997, *Is Australia an Asian country?* Allen & Unwin, NSW.
- Ingliss C., 2006, *Australia*, in *The encyclopaedia of the Chinese overseas*, Ed. L. Pan, Editions Didier Millet, Singapore.
- Jupp J., 1998, *Immigration*, Oxford University Press, UK.
- Ley D., 2010, *Millionaire migrants: Transpacific lifelines*, Wiley-Blackwell, UK.
- Ley, D., & Tutchener, J. (2001). *Immigration*, Globalisation and House Prices in Canada's Gateway Cities. *Housing Studies*, 16(2), 199-223
- Lund D., 2006, *Young overseas Chinese entrepreneurs in Australia*, In Ed. D. Ip, R. Hibbins and W. Chui, *Experiences of Transnational Chinese Migrants*,
- Mares P., 2016, *Not quite Australia: How temporary migration is changing the nation*, Text Publishing, Melbourne.
- Migration Heritage Centre, 2017, *Australia's migration history*, <http://www.migrationheritage.nsw.gov.au/belongings-home/about-belongings/australias-migration-history/>, viewed 25 April 2017.
- Museum Victoria, 2017, *History of immigration from China*, <https://museumvictoria.com.au/origins/history.aspx?pid=9>, viewed 25 April 2017.
- Phillips J., Klapdor M. & Simon-Davies J. 2010, *Migration to Australia since federation: a guide to the statistics*, Retrieved from <http://www.aph.gov.au/binaries/library/pubs/bn/sp/> , viewed 25 April 2017.
- Productivity Commission, 2016, *Migrant Intake into Australia*, Productivity Commission Inquiry Report, No. 77, 13 April 2016.

CRITICAL STEPS TAKEN IN THE UNITED STATES, BRAZIL AND AROUND THE WORLD TO IMPROVE PATIENT SAFETY: GLOBAL IMPLICATIONS FOR HOSPITALS AND MEDICAL ORGANIZATIONS

Mark Cwiek, George Kikano and Jacob Klaus
Central Michigan University, U.S.A.
Marcia Novaretti
Universidade Nove de Julho, U.S.A.
Drew Weil
UCLA Health, U.S.A.

ABSTRACT

Hospitals and medical clinics are complex organizations, and it is unfortunate but common around the world to have patient care compromised because of errors made during medical treatment. Errors and inefficiencies in healthcare delivery have led to inflated economic costs for providers, purchasers and recipients of medical treatment across the globe, and tragically, often with catastrophic patient outcomes. The United States of America and Brazil are two among many countries that have implemented systems for enhanced patient safety measures and reduced medical error. Various methodologies are looked at related to the mitigation of medical errors in both countries and elsewhere around the world, including institutional reporting of adverse events, admission of error and greater transparency by medical practitioners, professional peer review, and the use of checklists in interventional procedures. The authors recommend that healthcare systems across the globe strive to decrease clinical errors and improve quality of care through transparency, improvement of team processes, integration of knowledge, and analysis of root causes of error.

Keywords: Patient Safety, Hospitals, Physicians, Quality Improvement, Adverse Events.

INTRODUCTION

Patient safety is defined by the World Health Organization (WHO) as “the absence of preventable harm to a patient during the process of health care” (World Health Organization – Patient Safety Programme, 2017). Patient safety is a serious global public health issue. The magnificent patient safety vision statement of the WHO relates to all patients, everywhere, that all shall receive safe health care. Unfortunately, this is far from current reality in developing as well as in developed nations. According to WHO, as many as 1 in 10 patients are harmed while receiving care – *in developed countries*. Hospital-acquired infections are prevalent around the world, with 7 out of every 100 hospitalized patients in developed countries and 10 out of every 100 hospitalized patients in developing countries acquiring care-related infections. This reality exists even though simple prevention and control measures – such as appropriate hand hygiene – can reduce the frequency of care-acquired infections by 50% (World Health Organization – 10 Facts on Patient Safety, 2017).

This paper looks at various patient safety issues that exist around the globe, and particularly focuses on two disparate countries, the United States of America and Brazil. This paper discusses various programmatic approaches

implemented to improve patient safety, as well as some of the ongoing challenges and successes that have become manifest.

THE PUBLICATION THAT REVERBERATED AROUND THE WORLD: *To Err is Human*

The patient safety “movement” reached a tipping point in 2000 following the publication of the Institute of Medicine (IOM) entitled “To Err is Human,” where it was estimated that as many as 98,000 annual deaths could be caused by adverse events (errors) in the USA, surpassing deaths due to HIV, breast cancer and automobile accidents. It triggered a global mobilization for patient safety (Kohn, Corrigan & Donaldson, 2000).

In addition to the high cost of human lives, it was estimated in the 1999 *To Err is Human* report, that avoidable medical errors would generate total costs of \$17- \$29 billion a year in US hospitals. Errors are expensive also in terms of patients’ loss of confidence in the health system, thus decreasing the satisfaction of both patients and professionals working in the area. The conclusion of this report in 1999 was that, at that time, existing know-how could prevent many of these errors. It also set as a minimum objective a 50% reduction of errors over the five years following their publication (Kohn, Corrigan & Donaldson, 2000).

The repercussion of this report on the global medical community was such that the World Health Organization (WHO) focused on patient safety and launched the Alliance for Patient Safety in 2004 (WHO, 2004). This WHO initiative triggered several others in many countries with the aim of disseminating patient safety culture information among health professionals. Nevertheless, the underreporting of adverse events persists, partially explained by fear of consequences of reporting errors or due to lack of adequate tools to easily detect issues on a routine basis.

The WHO recommended to each member country around the world to develop a patient safety program with a sense of urgency that highlighted the fact that adverse patient safety events involve all age groups and most of these events are preventable. Moreover, adverse events compromise medical efficiency and increase medical costs. Adverse events can lead to additional tests and medications and result in longer hospital stays (Brilli, McClead, Crandall, Stoverock, Berry, Wheeler & Davis, 2013). Adverse events can lead to severe consequences. It has been reported that 13.6% of all adverse events may, in fact, cause the deaths of patients (Brennan, Leape, Laird, Herbert, Localio, Lawthers & Hiatt, 1991). Thus, the pursuit of efficiency in health is a global need, but it is especially important in countries with limited healthcare resources, such as Brazil (Machado, Lima & Andrade, 2014).

INTERNATIONAL COMPARISONS OF MEDICAL SAFETY CHALLENGES

Tremendous strides have been made over the past two decades to use large sources of patient data and to detect and analyze opportunities for improvement in quality of care and safety. Major studies have been conducted within various countries, including Canada, Australia, the United States and the United Kingdom (Johnson, Stoskopf & Shi, 2017). However, there are not many sources for comparative inter-country patient safety studies, and certainly not studies that have regular, annual reporting. It has been noted: “No one really knows how many errors or adverse events occur because of gaps in reporting processes and differences in definitions” (PriceWaterhouseCoopers, 2005).

While limiters exist in terms of international comparative data, the following data (see Tables 1, 2, 3) extracted from the website of The Commonwealth Fund provides results that are interesting and worthy of consideration (The Commonwealth Fund, 2017).

Table 1: Hospitalized Patients Reporting Infection in Hospital (2008)

Country	Hospitalized patients reporting infection in hospital
Australia	7.0%
Canada	6.0%
France	4.0%
Germany	6.0%
Netherlands	5.0%
New Zealand	11.0%
United Kingdom	10.0%
United States	7.0%

Base: Adults with any chronic condition and hospitalized in past two years

Sources: 2008 Commonwealth Fund International Health Policy Survey of Sicker Adults; C. Schoen et al., "In Chronic Condition: Experiences of Patients with Complex Health Care Needs, in Eight Countries, 2008." Health Affairs Web Exclusive, Nov 13, 2008

Table 2: Pharmacist or Doctor Did Not Review and Discuss Prescriptions in Past Year (2011)

Country	Pharmacist or Doctor Did Not Review and Discuss Prescriptions in Past Year
Australia	34%
Canada	28%
France	58%
Germany	29%
Netherlands	41%
New Zealand	31%
Norway	62%
Sweden	55%
Switzerland	25%
United Kingdom	16%
United States	28%

Base: Sicker Adults Taking Two or More Drugs

Source: 2011 Commonwealth Fund International Health Policy Survey in Eleven Countries

Table 3: Does Your Practice Have a Process for Identifying Adverse Events and Taking Follow-up Action? (2009)

Country	Yes, Works Well	Yes, Needs Improvement	No
Australia	32%	53%	15%
Canada	10%	31%	55%
France	18%	23%	58%
Germany	18%	30%	48%
Italy	13%	37%	48%
Netherlands	5%	25%	68%
New Zealand	32%	52%	15%
Norway	12%	47%	37%
Sweden	41%	44%	12%
United Kingdom	56%	38%	5%
United States	20%	45%	31%

Base: Primary Care Doctors

Sources: The Commonwealth Fund 2009 International Health Policy Survey of Primary Care Physicians in Eleven Countries; C. Schoen et al., "A Survey of Primary Care Physicians in Eleven Countries: Perspectives on Care, Costs, and Experiences, 2009." Health Affairs Web Exclusive, Nov. 5, 2009, w1171-w1183

The next table of Self-Reported Errors demonstrates data from a study conducted by 'The Commonwealth Fund's 2010 International Survey of the General Public's Views of their Health Care System's Performance in 11 Countries', which was conducted in Australia, Canada, France, Germany, the Netherlands, New Zealand, Norway, Sweden, Switzerland, the United Kingdom and the United States in 2010 (Schwappach, 2014).

The author noted that self-reporting of error by patients can be problematic in that poor care coordination “is the most important single risk factor for reporting errors across countries and in our country-specific analyses.” Further, “unavailable records, conflicting information and repetition of tests can signal, cause or coincide with safety events and can themselves be regarded as ‘error’, even if they may not cause harm. Thus, it seems likely that an unknown fraction of responders had the same event in mind when reporting coordination of care problems and error. This would lead to an overestimation of the association of coordination of care problems with error.”

It was further noted that hospital-associated error was reported to a higher level in some countries, such as Switzerland, which can be more of an indication of differences in organization of care in different systems. For example, access to a specialist in the outpatient setting is far more restrictive in some countries compared to others. Also, to the patient, perceived delays or failures in communication between professionals may be thought to be an indication of safety lapses, whereas the health care professionals may have a different perception of these issues (Schwappach, 2014).

Table 4: Frequency of self-reported errors by country, weighted data

Country	Medical error <i>n</i> (%)	Medication error <i>n</i> (%)	Either medical or medication error <i>n</i> (%)	Laboratory error* <i>n</i> (%)	Either medical, medication or laboratory error (aggregate measure) <i>n</i> (%)
*Based on those that reported blood test, X-rays or other tests in the past 2 years.					
Australia	282 (8.3)	155 (4.5)	350 (10.1)	69 (2.4)	395 (11.4)
Canada	212 (7.7)	179 (6.0)	322 (10.9)	106 (4.1)	372 (12.2)
France	87 (5.9)	110 (8.6)	157 (11.6)	39 (2.8)	178 (12.5)
Germany	54 (5.9)	20 (2.2)	64 (7.0)	12 (1.7)	73 (7.8)
Netherlands	52 (4.8)	45 (4.5)	82 (7.8)	25 (3.0)	97 (9.3)
New Zealand	59 (5.6)	39 (4.6)	82 (8.3)	19 (2.4)	92 (9.0)
Norway	101 (10.8)	79 (8.1)	147 (15.7)	29 (3.4)	161 (17.0)
Sweden	118 (6.1)	92 (4.9)	173 (8.9)	26 (1.9)	184 (9.5)
Switzerland	81 (8.0)	61 (5.3)	123 (11.4)	31 (3.2)	136 (11.9)
United Kingdom	39 (3.2)	25 (2.2)	55 (4.7)	21 (2.6)	66 (5.4)
United States	204 (9.7)	150 (6.4)	295 (12.9)	83 (5.0)	331 (14.3)

Source: Risk factors for patient-reported medical errors in eleven countries by David L. B. Schwappach MPH PhD;
First published: 1 February 2012

MISTAKES IN HEALTHCARE DELIVERY – COUNTING THE ECONOMIC COSTS

Despite enormous efforts, patient safety remains an elusive challenge in health care around the world. In the United Kingdom, 900,000 safety incidents were reported in 2008, of which 2,000 resulted in mortality. The cost against hospital service efficiencies was estimated to be £2 billion a year (House of Commons Health Committee, 2012).

A study conducted at Johns Hopkins Medicine indicate that medical errors are underreported and should rank as the third leading cause of deaths in the United States, with an estimation of more than 250,000 Americans dying each year from error, following behind only heart disease and cancer (Makary & Daniel, 2016). Medical errors, according to the study, would be rated higher officially if death certificates captured additional information beyond what is required in the use of International Classification of Disease (ICD) code set related to cause of death, such as human and system factors. Medical error, according to the authors, can include surgical complications that go unrecognized to errors with doses or types of medications administered to patients. This study therefore refutes as being too low the projected 98,000 deaths per year reported in the aforementioned seminal *To Err Is Human* report produced by the federal government in 1999 (Kohn, Corrigan & Donaldson, 2000). As part of this report, two large

studies occurred (one in Colorado and Utah, and the other in New York) which revealed that adverse events occurred in 2.9% and 3.7% of the respective hospitalizations. Further, it was shown that greater than half of these events occurred as a result of preventable medical error.

It is estimated that the annual cost of mistakes (or “preventable events”) made in healthcare delivery in the United States ranges between \$17 billion and \$29 billion (Kavaler & Alexander, 2014). The pressures continue to rise for hospitals in the United States, as the federal Medicare program for the elderly since 2007 no longer compensates facilities for the extra costs that may arise from treating preventable errors, infections and injuries that occur during hospital inpatient stays. State Medicaid programs for the indigent and private insurers have followed suit over the years.

The Centers for Medicare and Medicaid Services (CMS) in 2008 determined that “reasonably preventable” errors would not be reimbursed to hospitals, including conditions such as surgical site infections associated with elective procedures, Legionnaires disease, poor glycemic control, iatrogenic pneumothorax, delirium, ventilator-associated pneumonia, deep vein thrombosis/pulmonary embolism, staphylococcus aureus septicemia and clostridium difficile-associated disease. A year later, in 2009, CMS announced its intention to cease all payments to hospitals and physicians for three so-called 'never events': surgery on the wrong patient, the wrong surgical procedure and surgery on the wrong body part (Adrion & Anderson, 2009).

THE QUEST FOR IMPROVED RISK MANAGEMENT AND SAFETY OUTCOMES

Risk management, as it relates to healthcare organizations, has been defined as an organized effort to identify, assess, and reduce, where appropriate, risks to patients, visitors, staff, and organizational assets (Kavaler & Alexander, 2014). A more classic definition states that risk management is a program designed to reduce the incidence of preventable accidents and injuries to minimize the financial loss to the institution should an injury or accident occur (Smith & Wheeler, 1992). The business drivers for the typical healthcare risk management program include the following three functions: reduce the organization’s risk of malpractice suit by maintaining or improving quality of care; reduce the probability of a legal claim being filed after a potentially compensable event (PCE) has occurred; and preserve the organization’s assets once a claim has been filed (Kavaler & Alexander, 2014).

Patient safety therefore needs to be a primary goal of the risk management program within a healthcare organization. The Joint Commission, the international hospital and healthcare system accreditation body, created in 2016 the Hospital National Patient Safety Goals that specify the following seven key goals: Identify patients correctly; Improve staff communication; Use medications safely; Use alarms safely; Prevent infection; Identify patient safety risks; and Prevent mistakes in surgery (The Joint Commission, 2016). Various sub-goals are seen as follow:

Table 5: 2016 Hospital National Patient Safety Goals – The Joint Commission

Identify patients correctly	
NPSG.01.01.01	Use at least two ways to identify patients. For example, use the patient’s name and date of birth. This is done to make sure that each patient gets the correct medicine and treatment.
NPSG.01.03.01	Make sure that the correct patient gets the correct blood when they get a blood transfusion.
Improve staff communication	
NPSG.02.03.01	Get important test results to the right staff person on time.
Use medicines safely	
NPSG.03.04.01	Before a procedure, label medicines that are not labeled. For example, medicines in syringes, cups and basins. Do this in the area where medicines and supplies are set up.
NPSG.03.05.01	Take extra care with patients who take medicines to thin their blood.
NPSG.03.06.01	Record and pass along correct information about a patient’s medicines. Find out what medicines the patient is taking. Compare those medicines to new medicines given to the patient. Make sure the patient knows which medicines to take when they are at home. Tell the patient it is important to bring their up-to-date list of medicines every time they visit a doctor.
Use alarms safely	
NPSG.06.01.01	Make improvements to ensure that alarms on medical equipment are heard and responded to on time.
Prevent infection	
NPSG.07.01.01	Use the hand cleaning guidelines from the Centers for Disease Control and Prevention or the World Health Organization. Set goals for improving hand cleaning. Use the goals to improve hand cleaning.
NPSG.07.03.01	Use proven guidelines to prevent infections that are difficult to treat.
NPSG.07.04.01	Use proven guidelines to prevent infection of the blood from central lines.
NPSG.07.05.01	Use proven guidelines to prevent infection after surgery.
NPSG.07.06.01	Use proven guidelines to prevent infections of the urinary tract that are caused by catheters.
Identify patient safety risks	
NPSG.15.01.01	Find out which patients are most likely to try to commit suicide.
Prevent mistakes in surgery	
UP.01.01.01	Make sure that the correct surgery is done on the correct patient and at the correct place on the patient’s body.
UP.01.02.01	Mark the correct place on the patient’s body where the surgery is to be done.
UP.01.03.01	Pause before the surgery to make sure that a mistake is not being made.

Source: The Joint Commission (2016)

The Joint Commission requires that hospitals have an integrated patient safety system that includes programs to improve processes, integrate technology, maintain a standard way of caregivers to communicate and collaborate, and foster a “safety culture” (The Joint Commission, 2016). In this system, staff and management work together to eradicate complacency and learn from the safety events related to actual patient care experience.

Hospital staff are expected to be familiar with and understand the key terms used by the risk management professionals in the organization. A *patient safety event* is an event or incident that could result or did result in harm to the patient. An *adverse event* is an event that resulted in harm to the patient. A *sentinel event* represents an occurrence with the patient that results in death, permanent harm or severe temporary harm. A *hazardous condition* is a circumstance (other than the patient’s own disease process or condition) that increases the probability of an adverse event (The Joint Commission, 2016).

Several factors have been identified to optimize the efficacy of a hospital incident reporting system, including the need to have a system that is kept confidential, practical, user-friendly, and without fear of retribution. The focus must be on the overall process and on outcome improvement, and not on casting blame or accusing the person reporting an error. The organization must find ways to continuously support the ideals of trust and communication (McFadden, 2006).

DISCLOSURE AND APOLOGY

The United States is a litigious society and many medical providers fear lawsuits. Further, physicians and other caregivers hesitate to provide information related to medical error for fear of aiding a potential or actual plaintiff. Often, the malpractice insurance carrier is the party most interested in keeping information from the patient or patient's family when a medical error has occurred, resisting any actions that may be perceived to strengthen the suing party's case and putting greater amounts of money at risk. The common response in most healthcare institutions continues to be "deny and defend" when legal action is initiated because of patient injury (Boothman, 2009).

There are, however, some healthcare organizations that are pursuing a different strategy within the United States, often referred to as "disclosure and apology," providing greater transparency and an early opportunity to settle malpractice claims. Three principles have guided the University of Michigan Health System since 2001, in what has become known as the "Michigan Model:" 1) Patients harmed by unreasonable care should be made whole quickly and fairly; 2) caregivers must be supported when care was reasonable; and 3) the university (healthcare system) must learn from its mistakes (Adams, 2015).

Some organizations report remarkably positive results from adopting the disclosure and apology approach. The VA Medical Center in Lexington, Kentucky, a pioneer in the transparency movement, reported that it determined in a 13-year internal study it negotiated 170 settlements with an astounding mean cost of only \$36,000 per case, compared to the wholly different experience of the average VA hospital system nationwide of \$98,000 per case pre-trial, \$248,000 per case at trial and \$413,000 for cases going to full jury judgment (Curtis, 2010). In a study conducted by the University of Michigan Health System comparing its own malpractice claims before and after implementation of the disclosure and apology approach, new claims dropped from 7.03 per 100,000 patient encounters to 4.52; lawsuits dropped from 2.13 to 0.75; and time to restitution decreased from 1.36 years on average to 0.95 years (Adams, 2015).

It appears that fully integrated healthcare systems may have an advantage in the development and sustainment of a disclosure and apology approach to risk management and quality improvement. For purposes of this paper, "fully integrated" connotes organizations that have fewer independent parties to work with and the ability to exert great systemic control. Employment of physicians within a large, financially successful system can be an important component, as doctors otherwise might fear financial ruin from discussions with patients when a mistake has occurred. Likewise, the healthcare system's ownership of a malpractice insurance company (or having the ability to be "self-insured") can render the ability to conduct quick and full analysis of risk and culpability, and yet do this in an atmosphere of transparency (Boothman, 2009). In organizations utilizing the disclosure and apology approach, inclusion of the plaintiff's attorney with members of the healthcare team and family members while discussing possible settlement of the claim is not unusual (Mello, 2014).

While the full disclosure and apology approach may be more challenging to implement and maintain in hospitals and clinics that are not fully integrated, there are malpractice insurance companies that do support providers with a so-called "limited reimbursement" model. The limited reimbursement approach allows for providers to negotiate a quick maximum payout amount up to a certain amount, such as \$30,000. Compensation in such a model is typically allowed for such things as out-of-pocket expenses and loss of time. Waiver of medical bills by the providers is encouraged. However, unlike the full apology and disclosure approach adopted by integrated systems and discussed above, the limited reimbursement approach is disallowed (by the insurance carrier) whenever one or more of the following events occur: any attorney involvement by the plaintiff; the filing of a notice of complaint (initiating litigation); the filing of a complaint to a state medical board; or the filing of a complaint with a

regulatory agency. Of note, it is indicated that investigation of the standard of care and true systemic quality improvement over time is far more likely to occur in the integrated disclosure and apology approach, as compared to the limited reimbursement model (Mello, 2014).

PEER REVIEW

The board of the hospital has the affirmative legal duty to select physicians, to review credentials and to grant certain defined privileges to its various medical practitioners (Showalter, 2015, p. 245). As part of this responsibility, the governance of the organization ensures that peer review mechanisms exist, so that health care providers (i.e., doctors reviewing doctors) can evaluate their colleagues' work product, to determine if the requisite standard of care is being met and to determine if a preventable event has occurred (Newton, 2001). Peer review is grounded on three main principles: 1) only healthcare providers can effectively evaluate the clinical performance like clinical providers; 2) those participating in peer review must utilize candid communication; and 3) those participating in the process must be acting in good faith (Sullivan, 2010, p. 45).

Peer review can be a powerful mechanism for system improvement, and it has been observed that its purpose is to "improve hospital conditions and patient care or to reduce the rates of death and disease (Niven v. Siqueira, 1985). To participate in the Medicare program, hospitals are required to have a peer review program in place (Sullivan, 2010, p. 51). Congress has provided protection for providers who otherwise could be susceptible to federal antitrust claims by providers who do not fare well in the peer review process through passage of the Health Care Quality Improvement Act of 1986 (HCQIA). Through the HCQIA, a mechanism was developed for the reporting of negative findings on practitioners to the National Practitioner Data Bank (NPDB), so that a physician with a negative history would not be able to go to a different state and begin medical practice anew at a different hospital, without the worry of a negative history impacting credentialing decisions (Showalter 2015, p. 255).

Peer review, however, has its detractors. At times, professional peers have been thought to be "too friendly" in reviewing the work of fellow doctors, and in other situations, the professional peers have been blamed for being adversarial and vindictive (Kavaler, 2014, P. 286). Even with state statutes providing some level of protection for professional peers, many involved in the process fear future lawsuits by the reviewed individuals. Other negative aspects include the loss of time away from patients while reviewing other physicians, the possible loss of future patient referrals by one or more disgruntled physicians being reviewed, and fear of other forms of reprisal by other doctors (Sullivan, 2010, p. 50).

Despite these concerns, The Joint Commission's Hospital Accreditation Standards manual now focuses on the continuous evaluation of physician performance (as opposed to the more traditional two-year cycle for credentialing) that "not only allows any potential problems with a practitioner's performance to be identified and resolved as soon as possible, but also fosters a more efficient, evidence-based privilege renewal process" (Showalter, 2015, p.255). Both Medicare and The Joint Commission require that peer review involving practitioners' privileges must be objective, evidence-based and demonstrably fair. Those being reviewed therefore should have their due process rights protected by way of: notice, timely hearing, opportunity to produce witnesses and to cross-examine, access to a written report of findings and a mechanism for appeal (Showalter, 2015, p. 254).

Peer review, when properly implemented and resourced, can be a powerful tool that improves system quality, identifies areas of improvement for reviewed practitioners, helps to avoid medical errors, and aids in the avoidance of sizeable malpractice claims.

CHECKLISTS AND SURGERY: A REMARKABLE INTERNATIONAL STUDY

In the years 2007-08, eight hospitals in eight different cities and in eight different countries (including: Toronto, Canada; New Delhi, India; Amman, Jordan; Auckland, New Zealand; Manilla, Philippines; Ifakara, Tanzania; London, England; and Seattle, Washington in the USA) took part in a grand experiment to determine if the following of the guidelines of the World Health Organization's Safe Surgery Saves Lives program and the attendant Surgical Safety Checklist would yield a decrease in the rate of death (mortality) and complications due to surgery. The results of the study were astounding. All hospitals in the study demonstrated marked improvement, and on average complication fell 35%, the total hospital death rate fell by 47%, and overall rates of surgical-site infection and unplanned reoperation likewise declined. These results showed remarkable intra-study consistency, even though there were involved very diverse populations of patients and a variety of economic conditions (Haynes, Berry, Breizat, Herbosa, Lapitan, Moorthy & Gawande, 2009).

Gawande (2012), one of the surgeon-authors of the original study, provided in the transcript from his TED video presentation related to the eight country surgery study the importance of integrating the concept of checklist use from other complex and technical industries:

Well, in surgery, you couldn't have people who are more specialized and you couldn't have people who are better trained. And yet we see unconscionable levels of death, disability that could be avoided. And so we looked at what other high-risk industries do. We looked at skyscraper construction, we looked at the aviation world, and we found that they have technology, they have training, and then they have one other thing: They have checklists. I did not expect to be spending a significant part of my time as a Harvard surgeon worrying about checklists. And yet, what we found were that these were tools to help make experts better. We got the lead safety engineer for Boeing to help us.

Could we design a checklist for surgery? Not for the lowest people on the totem pole, but for the folks who were all the way around the chain, the entire team including the surgeons. And what they taught us was that designing a checklist to help people handle complexity actually involves more difficulty than I had understood. You have to think about things like pause points. You need to identify the moments in a process when you can actually catch a problem before it's a danger and do something about it. You have to identify that this is a before-takeoff checklist. And then you need to focus on the killer items. An aviation checklist, like this one for a single-engine plane, isn't a recipe for how to fly a plane, it's a reminder of the key things that get forgotten or missed if they're not checked.

So we did this. We created a 19-item two-minute checklist for surgical teams. We had the pause points immediately before anesthesia is given, immediately before the knife hits the skin, immediately before the patient leaves the room. And we had a mix of dumb stuff on there — making sure an antibiotic is given in the right time frame because that cuts the infection rate by half — and then interesting stuff, because you can't make a recipe for something as complicated as surgery. Instead, you can make a recipe for how to have a team that's prepared for the unexpected. And we had items like making sure everyone in the room had introduced themselves by name at the start of the day, because you get half a dozen people or more who are sometimes coming together as a team for the very first time that day that you're coming in. (13:26-16:00)

The elements of the WHO Surgical Safety Checklist, first edition, as used in the eight country study, is provided as follows.

Table 6: Elements of the Surgical Safety Checklist.*

<p>Sign in - Before induction of anesthesia, members of the team (at least the nurse and an anesthesia professional) orally confirm that:</p> <p>The patient has verified his or her identity, the surgical site and procedure, and consent The surgical site is marked or site marking is not applicable The pulse oximeter is on the patient and functioning All members of the team are aware of whether the patient has a known allergy The patient's airway and risk of aspiration have been evaluated and appropriate equipment and assistance are available If there is a risk of blood loss of at least 500 ml (or 7 ml/kg of body weight, in children), appropriate access and fluids are available</p> <p>Time out - Before skin incision, the entire team (nurses, surgeons, anesthesia professionals, and any others participating in the care of the patient) orally:</p> <p>Confirms that all team members have been introduced by name and role Confirms the patient's identity, surgical site, and procedure Reviews the anticipated critical events Surgeon reviews critical and unexpected steps, operative duration, and anticipated blood loss Anesthesia staff review concerns specific to the patient Nursing staff review confirmation of sterility, equipment availability, and other concerns Confirms that prophylactic antibiotics have been administered ≤ 60 min before incision is made or that antibiotics are not indicated Confirms that all essential imaging results for the correct patient are displayed in the operating room</p> <p>Sign out - Before the patient leaves the operating room:</p> <p>Nurse reviews items aloud with the team Name of the procedure as recorded That the needle, sponge, and instrument counts are complete (or not applicable) That the specimen (if any) is correctly labeled, including with the patient's name Whether there are any issues with equipment to be addressed The surgeon, nurse, and anesthesia professional review aloud the key concerns for the recovery and care of the patient</p>

Source: World Health Organization: Safe Surgery Saves Lives.

* The checklist is based on the first edition of the WHO Guidelines for Safe Surgery.

THE BRAZILIAN PATIENT SAFETY EXPERIENCE

In Brazil, the Federal Agency of Health Vigilance (ANVISA) launched a Federal resolution in 2010 stating that the management of the risks inherent to the activities carried out in health care units, as well as the health care products, should be under sanitary control and inspection. In the same document, it was determined that the health care facility should seek to reduce and minimize the occurrence of adverse events related to: I - procedures for the prevention, diagnosis, treatment or rehabilitation of the patient; II - pharmaceutical drugs and supplies; III - health products including equipment; IV - use of blood and blood components; V - sanitizers; and VI - other products subject to sanitary control and inspection used in the unit. However, it did not specify how this would be accomplished. (ANVISA, 2010).

The percentage of adverse event that can be considered preventable varies in the literature from 27 to 66.7%, reinforcing the need to find ways to avoid these incidents (Porto, Martins, Mendes & Travassos, 2010). Several studies have been conducted to correlate the avoidable incident rate and expenditures with adverse events in countries such as the United States, the United Kingdom, the Netherlands, Australia, New Zealand, Canada and Brazil (Thomas, Studdert, Newhouse, Zbar, Howard, Williams & Brennan, 1999; and Mendes, Martins, Rozenfeld & Travassos, 2009). Porto and colleagues made an analysis of these studies and concluded that from 2.3 to 10.8% of

hospitalized patients suffer from adverse incidents and that they have increased up to 8.5 days of hospitalization in the United Kingdom, with a cost that can reach 48% of the overall hospitalization costs.

A survey conducted in Brazil analyzed 622 medical records of two teaching hospitals, and found that 6.3% of the patients suffered adverse incidents, of which 64.1% were considered avoidable, with an average increase in the hospitalization period of 4.6% (two days). The authors pointed out that one of the limitations of the study, which may underestimate the results presented, is the fact that the wages of the health care employees involved in the care were not accounted for (Porto et al., 2010).

In another study in Brazil, a specific tool for reporting patient incidents was used which identified 38.5% of these as administrative occurrences (equipment problems, infrastructure failures and staff shortages, non-compliance to administrative operating procedures, conflicts and miscommunication, and medications shortage). These researchers showed that problems related to equipment maintenance were frequent (31.9%), but the lack of disposables was also significant (15.1%), as well as the lack of infrastructure (17.1%), lack of human resources (11%) and loss of documents (4.1%), among other things (Paiva, Paiva & Berti, 2010).

In 2013, the Brazilian Ministry of Health published the Brazilian National Patient Safety Program (PNSP), establishing the mandatory implementation of PNSP in health services throughout all of Brazil. The Safety Nucleus of Patients of each health care facility should develop a Patient Safety Plan (PSP) in order to promote greater safety for patients, professionals and the health care environment. The PNSP considers that risk management should be focused on patient quality and safety, encompassing principles and guidelines such as the development of a safety culture; systematic and structured risk management processes; integration with all processes of care and articulation with the organizational processes of health services; the best evidence available; transparency, inclusion, accountability and awareness and the capacity to react to change; and developing strategies, products and actions aimed at health managers, professionals and users about patient safety, that allow for the mitigation of occurrence of adverse events in health care (Reis, Martins & Laguardia, 2013).

Despite this federal resolution, unfortunately, there are only a small number of research projects focusing on adverse events in Brazilian hospitals at this time. In 2014, Novaretti and colleagues demonstrated in a prospective study that nursing work overload was directly related to the increase of adverse events related to intensive care unit (ICU) patients. It was further shown that a connection exists between nursing overload and death risk for patients (Novaretti, Santos, Quiterio & Daud-Gallotti, 2014).

Miscommunication in the Brazilian intensive care unit was also studied. It was determined that 6.6% of patient safety incidents were due to miscommunication. Most of these incidents were related to failure in following protocols/clinical procedures (39.0%). Patients with more comorbidities were prone to more miscommunication incidents ($p < 0.0005$). Adverse events were linked to 248 (24.8%) cases. In this study, all adverse events related to miscommunication were of preventable type, demonstrating that the ICU manager and the team can develop strategies for improving communication among ICU staff members, patients and families and thereby preventing patient safety incidents (Novaretti, et al 2014).

Incidents arising from the provision of healthcare services that are well defined but rarely studied have been the incidents related to administrative processes, especially in the intensive care unit. In another Brazilian study, the aim was to analyze the influence of administrative processes in the safety of ICU patients. A descriptive exploratory empirical approach was utilized to perform this research. Data from medical records were obtained and collected daily. Additional information from medical and nursing visits were also noted in an appropriate form for reporting safety incidents and compared with the records in the chart. In this study, 9,396 incidents were found in 202 admissions. Of these, 653 (6.94%) in 148 admissions were classified as administrative incidents. Thus, it was concluded that administrative incidents occupy a small but important portion of total incidents (6.94%), occurring in processes that directly affect the care provided and may cause serious harm to patients, and even death. Almost all safety incidents related to administrative failures were considered preventable, therefore justifying the development and implementation of measures to prevent such occurrences (Novaretti, Santos & Waldman, 2017).

RECOMMENDATIONS

The authors recommend that healthcare systems around the world strive to decrease clinical error and improve quality of care through continuous re-dedication to team systems, integration of knowledge, transparency, and analysis of root causes of error. Mechanisms worthy of continued study and enhanced application include institutional reporting of adverse events, admission of error and greater transparency by medical practitioners, professional peer review, and the use of checklists in interventional procedures.

CONCLUSIONS

There are, unfortunately, many examples in the global delivery of medical services where it can be demonstrated that the most expensive modalities are often not the most effective in terms of delivering the most positive clinical outcomes. More and more, healthcare organizations need to be striving with renewed dedication and passion toward error reduction, improved systems thinking, development of teams of experts and greater transparency.

REFERENCES

- Adrion, E. & Anderson, G. (2009). Hospital errors no longer covered by Medicare, *Health Policy Monitor*. Retrieved January 7, 2017 from <http://www.hpm.org/survey/us/b14/3>
- ANVISA (2010). Resolução da diretoria colegiada – RDC nº 7, de 25 de fevereiro de 2010. Dispõe sobre os requisitos mínimos para funcionamento de Unidades de Terapia Intensiva e dá outras providências. Brasil. D.O.U. Recuperado em 13 maio, 2014, de http://www.saude.mg.gov.br/images/documentos/RDC-7_ANVISA%20240210.pdf
- Boothman, R., Blackwell, A., Campbell Jr., D., Commiskey, E. & Anderson, S. (2009). A better approach to medical malpractice claims? The University of Michigan experience, *Journal of Health & Life Sciences Law*, Jan: 2(2): 125-159.
- Brennan, T., Leape, L., Laird, N., Hebert, L., Localio, A., Lawthers, A. & Hiatt, H. (1991). Incidence of adverse events and negligence in hospitalized patients: Results of the Harvard Medical Practice Study I. *New England Journal of Medicine*, 324(6), 370-376.
- Brilli, R., McClead, R., Crandall, W., Stoverock, L., Berry, J., Wheeler, T., & Davis, J. (2013). A comprehensive patient safety program can significantly reduce preventable harm, associated costs, and hospital mortality. *The Journal of Pediatrics*, 163(6), 1638-1645
- Curtis, D. (2010). Sometimes, an apology can deter a lawsuit, *California Bar Journal*, July.
- Gawande, A. (2012) How do we heal medicine? Transcript of video TED presentation. Retrieved April 3, 2017 from https://www.ted.com/talks/atul_gawande_how_do_we_heal_medicine/transcript?language=en
- Haynes, A., Berry, W., Breizat, A., Herbosa, T., Lapitan, M., Moorthy K. & Gawande, A. (2009). A surgical safety checklist to reduce morbidity and mortality in a global population. *The New England Journal of Medicine*, 360:491-9.
- House of Commons Health Committee (2016). *Patient Safety: Sixth report of session 2008–09*. Retrieved March 27, 2017 from <http://www.publications.parliament.uk/pa/cm200809/cmselect/cmhealth/cmhealth.htm>

- Johnson, J., Stoskopf, C. & Shi, L. (Eds.) (2nd ed.) (2018). *Comparative Health Systems: A global perspective*. Burlington, MA: Jones & Bartlett Learning.
- Kavaler, F. & Alexander S. A. (2014). *Risk management in healthcare institutions* (3rd ed.). Burlington, MA: Jones & Bartlett Learning.
- Kohn, L., Corrigan J., Donaldson, M. (Eds.) (2000). *To err is human: Building a safer health system*. Institute of Medicine, National Academy of Sciences.
- Machado C., Lima L. & Andrade C. (2014). Federal funding of health policy in Brazil: Trends and challenges. *Cadernos de Saúde Pública* 2014, 30:187–200.
- Makery, M. & Daniel, M. (2016). Medical error – the third leading cause of death in the US, *BMJ*, 2016;353:i2139.
- McFadden, K., Stock, G., Gowen, C. (2006). Exploring strategies for reducing hospital errors. *Journal of Healthcare Management*, 51(2), 123.
- Mello, M., Boothman, R., McDonald, T., Driver, J., Lembitz, A., Bouwmeester, D., Dunlap, B. & Gallagher, T. (2014). Communication-and-resolution programs: The challenges and lessons learned from six early adaptors. *Health Affairs*, 33(1): 20-29.
- Mendes, W., Martins, M., Rozenfeld, S., & Travassos, C. (2009). The assessment of adverse events in hospitals in Brazil. *International Journal for Quality in Health Care*, 21(4), 279-284.
- Novaretti, M., Santos, E., Quitério, L. & Daud-Gallotti, R. (2014). Nursing workload and occurrence of incidents and adverse events in ICU patients. *Revista brasileira de enfermagem*, 67(5), 692-699.
- Novaretti, M., Santos, E. & Waldman, C. (2017) Administrative failures in an ICU teaching hospital. *Spacios*, 37, 36, 2017.
- Newton, G. (2001). Maintaining the balance: Reconciling the social and judicial costs of medical peer review protection. *Alabama Law Review*, 52, 723.
- Niven v. Siqueira, 487 N.E. 2d, 937,942 (Ill. 1985).
- Paiva, M., Paiva, S. & Berti, H. (2010). Eventos adversos: análise de um instrumento de notificação utilizado no gerenciamento de enfermagem. *Rev Esc Enferm USP*, 44(2), 287-94.
- Porto, S., Martins, M., Mendes, W. & Travassos, C. (2010). A magnitude financeira dos eventos adversos em hospitais no Brasil. *Revista Portuguesa de Saúde Pública*, (s10).
- PriceWaterhouseCoopers (2005). *HealthCast 2020: Creating a sustainable future*. Washington, D.C.: Health Research Institute, 33.
- Reis, C. T., Martins, M., & Laguardia, J. (2013). A segurança do paciente como dimensão da qualidade do cuidado de saúde—um olhar sobre a literatura. *Ciência & Saúde Coletiva*, 18(7), 2029-2036.
- Schwappach, D. (2014). Risk factors for patient-reported medical errors in eleven countries. *Health expectations*, 17(3), 321-331. Retrieved April 2, 2017 from <http://onlinelibrary.wiley.com/doi/10.1111/j.1369-7625.2011.00755.x/full>
- Showalter, J. S. (2015). *The law of healthcare administration* (7th ed.). Chicago, IL: Health Administration Press.

Smith, D. & Wheeler, J. (1992). Strategies and structures for hospital risk management programs. *Health Care Management Review*, 17(3), 9-17.

Sullivan, P. & Anderson, J. (2010). The health care debate: If lack of tort reform is part of the problem, federalized protection for peer review needs to be part of the solution. *Roger Williams University Law Review*, 15, 41.

The Commonwealth Fund (2017). Surveys & Data, International Safety Data, Results. Retrieved April 2, 2017 from <http://www.commonwealthfund.org/interactives-and-data/international-survey-data>

The Joint Commission. (2016). 2016 hospital national patient safety goals. Retrieved January 7, 2017 from https://www.jointcommission.org/assets/1/6/2016_NPSG_HAP_ER.pdf

Thomas, E, Studdert, D., Newhouse, J., Zbar, B., Howard, K., Williams, E. & Brennan, T. (1999). Costs of medical injuries in Utah and Colorado. *Inquiry*, 255-264.

World Health Organization. (2004). *World alliance for patient safety: Forward programme*.

World Health Organization (2008). *Safe surgery saves lives*. Retrieved April 3, 2017 from http://www.who.int/patientsafety/safesurgery/knowledge_base/SSSL_Brochure_finalJun08.pdf

World Health Organization – 10 facts on patient safety (2017). Retrieved January 7, 2017 from http://www.who.int/features/factfiles/patient_safety/en/

World Health Organization – Patient Safety Programme (2017). Retrieved January 7, 2017 from <http://www.who.int/patientsafety/about/en/>

CHOICE FACTORS OF RESTAURANT PATRONS IN THE MARKETING OF RESTAURANTS IN SOUTH AFRICA

Jessica Day
Monash, South Africa

Reaan Immelman and Mornay Roberts-Lombard
University of Johannesburg, South Africa

ABSTRACT

Almost everyone enjoys a great restaurant and the objective of the paper is to recommend marketing guidelines for restaurant owners in South Africa with the aim to attract more customers. This objective was achieved by identifying the choice factors of restaurant patrons when selecting a restaurant. The methodology followed was quantitative in nature and the sample consisted of 200 respondents from five restaurants in South Africa. A total of 12 choice factors were identified when restaurant patrons select their restaurant of choice. Food quality, service quality and value for money was identified as the most important choice factors in the selection process.

Keywords: Restaurants, marketing, choice factors, consumer behaviour, integrated marketing communication.

INTRODUCTION

Globally, the food services industry is one of the largest industries accounting for up to \$660 billion in the United States (Vault, 2015). In the South African context, the value of sales in South Africa in the restaurant industry reached R27.8 billion in 2015 (Passport, 2013) and employs more than 1.7 million (Ntloedibe, 2014). The level of competition in the restaurant industry is extremely fierce and restaurants are opening on a daily basis and hence the marketing of all restaurants are very important (Spencer, 2015).

PROBLEM INVESTIGATED AND RESEARCH OBJECTIVE

According to Feloni, (2014), the life span of new restaurants is very short and around 60 percent of new restaurants fail within the first year and nearly 80 percent shutter before their fifth anniversary. <http://www.cnbc.com/2016/01/20/heres-the-real-reason-why-most-restaurants-fail.html>. It is therefore important for restaurants to market themselves and consumers play a vital role in the decision making process when selecting a restaurant that appeals to their particular needs and wants (Alonso, O'neill, Liu, & O'shea, 2013). The problem statement suggests that restaurants find it difficult to market themselves successfully due to an insufficient amount of information relating to the choice factors of customers when selecting a restaurant. The primary objective of this study is to recommend marketing guidelines for restaurant owners in South Africa with the aim in attracting more customers. The secondary objectives are to identify choice factors influencing customers' selection of restaurants and to determine the most important choice factors influencing the selection of restaurants.

LITERATURE REVIEW

The marketing of restaurants are evident at some restaurants in South Africa such as Panarotti's and Spur who advertise their promotions on billboards (Primedia, 2017) and also include word-of-mouth, digital marketing such as Search Engine Optimisation (SEO) and social media (Gourmet Marketing, 2015). Magazine advertising such as the Food and Home magazine, EatOut magazine and Zomato (Food & Home, 2016) are also evident. Research into choice factors of restaurant patrons when selecting a restaurant includes amongst others international studies by Alonso, et.al, 2013, Dutta, Parsa, Parsa and Bujisic, 2012, Parsa and Self, 2012 and Cullen, 2005. Alonso, et.al, 2013 identified the food provided (quality and taste) as central to respondents' decision to favour one restaurant over another, as well as a positive dining experience, a clean service environment and hospitable service as the most strongly influenced restaurant choice. Dutta et.al, 2012 indicated that restaurateurs have a strategic advantage when they choose high quality food and an appropriate level of service or ambiance. A study by Parsa and Self, 2012 identify food quality, service quality and the overall restaurant environment as the most important choice factors while Cullen, 2005 identified quality of the food, type of food, cleanliness of the restaurant and reputation of the restaurant as the key attributes used by consumers to select restaurants. As far as could be ascertained, no research exists with specific reference to choice factors that restaurant patrons considered in the selection of restaurants in the South African context.

RESEARCH METHODOLOGY

The empirical investigation was quantitative in nature. The population comprised all restaurant patrons in the West of Johannesburg in the Gauteng Province of South Africa. A non-probability sampling approach was followed and the convenience sampling technique was applied. The data was gathered over a four week period in 2016 and restaurants include Mugg-a-Bean, Fego, Doppio Zero, Ocean Basket and Mythos at Cradestone Mall. During this time, restaurant patrons who matched the sampling frame were asked to participate in the survey. A total of 200 questionnaires were completed and could be used in the analysis.

RESULTS

Cronbach's alpha was used as a measure of the internal consistency reliability for the measurement of the importance of the attributes. Cronbach alphas above 0.6 are deemed to have a good strength of association and are acceptable (Malhotra, Baalbaki and Bechwati, 2013). The reliability statistics for the questionnaire are presented in table 1.

Table 1: Cronbach's Alpha

Factor	Cronbach's alpha coefficient
Factor 1	0.894
Factor 2	0.634
Factor 3	0.689

It is evident from Table 1 that the Cronbach alpha coefficients for Factor 1 (food quality, service quality, dining experience, value for money, menu price, variety of food menu) are 0.894, Factor 2 (parking, healthy alternatives and suitability of children) are 0.634 and Factor 3 (social status, location and restaurant reputation) are 0.689.

VALIDITY

Validity can be attained by aligning the content of the questionnaire with the research objectives. Consequently, the following activities were performed to ensure validity and reliability:

- A self-administrated questionnaire was designed, which was directly aligned with the research objectives.
- A large sample size (200 respondents) was used to increase the accuracy of the results.
- A statistical consultant was employed to analyse the data gathered and to ensure the correct measurements of the results.
- Factor analysis was used to assess the structural validity of the choice factors construct and exploratory factor analysis was used in an attempt to gain insight into the structural validity. The 12 items of the choice factor scale were according to Pallant (2013) subjected to principal component analysis (PCA) and prior to performing PCA, the suitability of data for factor analysis was assessed using the Kaiser-Meyer-Olkin (KMO) test for sampling adequacy and Bartlett’s test of Sphericity results. This is presented in Table 2.

Table 2: KMO and Bartlett’s Test of Sphericity

Test		Value of Forced EFA
Kaiser-Meyer-Olkin Measure of Sampling Adequacy		0.827
Bartlett’s Test of Sphericity	Approx. Chi-square	756.930
	DF	66
	Sig	0.000

It is evident from Table 2 that the Kaiser-Meyer-Olkin value was 0.827, exceeding the recommended value of 0.6 and Bartlett’s Test of Sphericity reached statistical significance, supporting the factorability of the correlation matrix. Communalities are investigated and provide information about how much of the variance in each item is explained. Principal Axis Factoring as extraction method were used and Varimax for rotation Four factors explain a total of 61.68% of the variance. Factor 1 (or component) contributes 42.51%, factor 2 contributes 52.07%, factor 3 contributes 57.92%, and factor 4 contributes 61.68% of the total variance explained.

DEMOGRAPHIC PROFILE OF RESPONDENTS AND CHOICE FACTORS INFLUENCING THE SELECTION OF RESTAURANTS

Considering that a total of 200 respondents participated in the study, 50% were female, 48% were married and the majority of respondents (61%) reside in the Northern and Western suburbs of Johannesburg. Concerning the research objective, respondents identified 12 variables that they considered as valuable choice factors when selecting a restaurant of choice.

Table 3: Choice factors of restaurant patrons

Choice Factor	Mean	Standard Deviation
Dining experience	3,72	1,288
Social Status	3,27	1,202
Service quality	3,94	1,295
Food quality	4,06	1,328
Value for money	3,78	1,167
Location	3,42	1,217
Restaurant reputation	3,64	1,103
Menu Price	3,56	1,032
Suitability for children	2,85	1,518
Parking	3,28	1,280
Variety of food menu	3,64	1,186
Healthy alternatives for dietary needs	3,17	1,362

From Table 3, the main finding is that food quality realised an overall mean score above 4. This is followed by service quality (mean of 3.94), value for money (mean of 3.78) and the dining experience (mean of 3.72). Interesting to note is that suitability for children is cited as the least important choice factor (mean of 2.85). This finding is mainly due to the fact that the restaurants surveyed at Cradlestone Mall (Mugg-a-Bean, Fego, Doppio Zero, Ocean Basket and Mythos) is not traditional child friendly restaurants.

MANAGERIAL IMPLICATIONS AND RECOMMENDATIONS

Food quality is the most important choice factor of restaurant patrons when selecting a restaurant and this finding correspond with the study of Alonso et.al, 2013, Para et.al 2012, Para and Self, 2012 as well as Cullen, 2005, who cited food quality as the most important choice factor. In this study service quality was the second most important choice factor and corresponds with the findings of Para and Self, 2008.

RECOMMENDATIONS

Service Product and People

As food quality is ranked as the most important for restaurant patrons, it is recommended that quality of food is of the highest standard at any restaurant. Food quality is enhanced by a variety of food items on the menu and can include healthy food for the health conscious as well as restaurant patrons with dietary needs. Restaurants can encourage patrons to make suggestions to the menu of the restaurants in an effort to satisfy client's needs.

Quality of service is ranked as the second most important choice factor when restaurant patrons select a restaurant and this can only be accomplished through people. The restaurant owner/s must be involved in the daily management of the restaurant and training of the restaurant manager is of utmost importance. A recommendation is the continuous upskilling of the frontline staff (waiters) in the restaurant. On the job training by the restaurant manager is imperative and could be enhanced by exposing the front line staff to short learning courses such as short courses in customer service, communication skills and emotional intelligence.

Price, Place and Physical Evidence

With an economic growth rate of less than 1% in South Africa, consumers will have less money to spend at restaurants, hence the importance of value for money in the selection process of restaurant patrons. It is recommended that the restaurant cater for a variety of different meals that will cater for different income brackets. An example is light meals such as sandwiches and burgers. Many restaurants implemented special prices on certain days of the week such as Buy one Get one Free on Monday nights. A price strategy is always important in a struggling economy and it is recommended that restaurants continue with a lower price strategy at certain times of the week. Another recommendation for restaurants near education institutions (such as schools and universities) is to have promotions on certain days or for restaurants to sponsor big school events such as soccer or rugby festivals in order to attract new customers. Physical evidence is the one element of the marketing mix which allows customers to compare tangible aspects of a service. In a restaurant this can take many forms such as the dining experience and parking available for restaurant patrons. In the context of this study, the location of the restaurant was at Cradlestone Mall, one of the biggest shopping malls in the Gauteng Province of South Africa. It is recommended that when restaurant owners want to open a restaurant, that they select a restaurant near high volume traffic in the mall such as a supermarket. It is also recommended that restaurant owners ensure cleanliness of their restaurant, including the bathrooms of the restaurant and to ensure that the table cloths are cleaned after each meal. The final recommendation is that restaurants need to make provision for children. This may include an introduction of a children's menu, a dedicated play area, face-paint for children, arranged activities for children as well as supervision for children by restaurant staff.

Process

Process in the context of a restaurant start with the reservation of a table. It is recommended that this process is automated through a mobile app or website reservation for those restaurant patrons who prefer to make a reservation for a restaurant.

When a reservation is made or potential patrons are walking into a restaurant, it is imperative that the patrons are accompanied by the restaurant manager or a dedicated waiter. It is recommended that the waiter must be assigned immediately to the table to create a pleasant service experience from the start. At any point in time during the dining experience, it is recommended that a service button is installed at the table if the restaurant patrons require service. The payment process of the patrons can also be fastened if patrons can pay by means of payment devices such as Zapper, SnapScan and any fast card acceptance machines from banks. This will enhance the service quality of restaurant patrons. It is also recommended that the restaurant have an effective website or mobile phone application for general information purposes as well as the option for patrons to order meals online as well as an effective delivery system to restaurant patrons.

LIMITATIONS OF THE STUDY

The limitation of the study is that it is only limited to the largest city of South Africa and the results cannot be generalised to other cities in the country. Another limitation of the study is that restaurants did not include child friendly restaurants.

CONCLUSION

The research succeeded in investigating the importance of choice factors when restaurant patrons select a restaurant of choice. The study revealed 12 choice factors and quality of food, service quality and value for money was cited as the most important choice factors. Although suitability for children was cited the least important choice factors, it can be seen as the biggest opportunity for restaurants without provision for child friendliness. This study contributes

to research in the South African context of consumer behaviour, with specific reference to choice factors that restaurant patrons considered in the selection of restaurants.

REFERENCES

- Alonso, A. D., O'Neill, M., Liu, Y. & O'Shea, M., 2013. Factors Driving Consumer Restaurant Choice: An Exploratory Study From the Southeastern United States. *Journal of Hospitality Marketing & Management*, 22(5), pp. 547-567.
- Blythe, J. 2013. *Consumer Behaviour*. 2nd ed. London: South-Western.
- Cullen, F. 2005. Factors influencing restaurant selection in Dublin. *Journal of Foodservice Business Research*, 71(6), pp53-85.
- Dutta, K., Parsa, H.G., Parsa, A.R. & Bujisic, M. (2013). Change in consumer patronage and willingness to pay at different levels of service attributes in restaurants. A study from India. *Journal of Quality Assurance in Hospitality and Tourism*, 15(2), 149-174
- Feloni, R., 2014. Why Restaurants Fail so often. [Online] Available at: <http://www.businessinsider.com/why-restaurants-fail-so-often-2014-2> [Accessed 26 August 2015].
- Food & Home, 2016. Food & Home: Zomato and Uber announce a global tie-up to enhanced restaurant lovers' dining experience. [Online] Available at: <http://www.foodandhome.co.za/article.aspx?id=68321&h=Zomato-and-Uber-announce-a-global-tie-up-to-enhanced-restaurant-lovers%E2%80%99-dining-experience-> [Accessed 25 May 2016].
- Gourmet Marketing, 2015. Restaurant Marketing Made Easy. [Online] Available at: <http://www.gourmetmarketing.net/> [Accessed 10 September 2015].
- Malhotra, N. K., Baalbaki, I. B. & Bechwati, N. N., 2013. *Marketing Research: An Applied Orientation*. Arab world edition ed. Essex: Pearsons.
- Mealey, L., 2015. Different Types of Restaurant Concepts: How to Select a Restaurant Theme. [Online] Available at: <http://restaurants.about.com/od/restaurantconcepts/tp/Different-Types-Of-Restaurant-Concepts.htm> [Accessed 8 September 2015].
- Parsa, H.G. and Self, J.T. 2012. Consumer Behaviour in Restaurants: Assessing the importance of restaurant attributes in consumer patronage and willingness to pay, *Journal of Services Research*, 12 (2), pp 1-20.
- Passport, 2013. *Dining out around the world*, s.l.: Euromonitor International.
- Primedia. 2017. *Spur Advertising (Billboard)*.
- Spencer, M. E., 2015. Industry Analys: Restaurants. [Online] Available at http://www.valueline.com/Stocks/Industries/Industry_Analysis__Restaurant.aspx#.VfP5tvmeDGc [Accessed 9 September 2015].
- Vault, 2015. Restaurants and Food Services: Overview. [Online] Available at: <http://www.vault.com/industries-professions/industries/restaurants-and-food-services.aspx> [Accessed 8 September 2015].

MARGINAL ANALYSIS OF PROJECT RESOURCE SLACK ON RISKS PERCEPTION

Hélène Delerue and Hélène Sicotte
University of Quebec at Montreal, Canada

ABSTRACT

Risk management has been designated as one of the eight main areas of the Project Management Body of Knowledge (PMBOK). Nevertheless, risk is understood as an “inherently subjective construct.” This research investigates the relationship between slack and risk perception in projects and addresses the following question: How do slack resources affect project risk perception? Results show that resource slack and constraint do not influence all kind of risks perception.

Keywords: Financial Slack, Human Resources Slack, Risks Perceptions, Project

INTRODUCTION

Classic project risk management proposes three processes: risk identification, evaluation and analysis. The way the identification process is conducted will have a direct influence on the contribution that risk analysis and management makes to the overall project management (Chapman, 2001). Nevertheless, risk identification is based on risks perception (Thevendran & Mawdesley, 2004). Risk perception is defined as “a decision-maker's assessment of the risk inherent in a situation” (Sitkin & Pablo, 1992). Different people may have different risk perceptions of the same situation.

Risk management is time and resource consuming and often needs flexibility (Huchzermeier & Loch, 2001). Flexibility is facilitated by slack resources (Adkins, 2005). Slack implies the presence of resources in excess of what is required for "normal" efficient operation of a firm (Bourgeois, 1981). Slack can have three main functions. First, slack provide projects with sufficient resources to capitalize on external opportunities permitting them to enjoy continuous growth except where managerial capabilities are inadequate (Kor & Mahoney, 2004). Second, slack resources enable projects to conduct additional experimentations, thus enhancing innovation and risk-taking (Singh, 1986). Third, slack resources can absorb environmental turbulence or buffer the technical core from environmental influence (Bourgeois, 1981; Cyert & March, 1963). It has therefore been shown that slack increases risk taking (Singh, 1986). However, there is no consensus on the effects of slack. Other researchers consider that slack diminishes the willingness to accept risk (Miller & Leiblein, 1996).

There are different types of slack. The literature distinguishes bundles of financial (i.e., excess financial resources) and human resource (HR) slack (i.e., excess employees on the payroll) (Paleman & Vanacker, 2015). Therefore, risks perception can be compared empirically regarding the type of slack to determine whether resource slack impacts risk perceptions.

Most studies operationalize resource slack and constraints at the firm level (e.g Singh, 1986; Paleman & Vanacker, 2015). This research takes another point of view by investigating the relationship between slack and risk perception in projects and addresses the following question: How do slack resources affect project risk perception? By distinguishing the different type of slack (financial slack and human resource (RH) slack), we investigate in which cases risk are perceived as more prevalent. To answer these questions, we compare risks perception regarding the level of project slack.

RISK PERCEPTION AND RESOURCE SLACK

In order to manage uncertainty and exploit opportunities, prior scholars recommend slack resources as a strategic tool for facilitation of risk taking (Nohria & Gulati, 1996; Singh, 1986; Woodman et al., 1993) because slack protects from uncertain project outcomes (Nohria & Gulati, 1996). Slack is defined as “the difference between the minimum resources necessary to produce a given output and some higher level actually observe” (Wiseman & Bromiley, 1996: 526). From a psychological viewpoint, risk behavior is more likely in the presence of slack resources (Singh, 1986) because the legitimacy of experimenting is less likely to be questioned (Thompson, 1969). The lack of available slack inhibits a firm's ability to mobilize necessary resources and constrain strategic change and aggressiveness (Ferrier, 2001). As organizational slack is reduced, creativity and idea generation are affected, because there is not enough room in the project, since there is only time for the most necessary activities (Amabile & Conti, 1999).

Risk taking behaviour is determined by risk perception (Sitkin & Pablo, 1992). However, risks perception is biased in several ways. According to Tversky and Kahneman (1975), individuals manage information through simplifying principles and make decisions based on both subjective probabilities that are difficult to estimate and heuristics that reduce complexity. In the perspective of the cognitive and behavioral theories, individuals develop their own representations of reality called "cognitive schemes" that allow them to interpret and explain events (March & Simon, 1958). Several authors have shown that risk perception is contingent on situational characteristics (Sitkin & Weingart, 1995; Sitkin & Pablo, 1992). Sitkin and Weingart (1995) show that the degree to which individuals make risky decisions is negatively associated with their level of perceived risk. Thus, in presence of slack resources, risk level perception may be lower because some measures can be put in place to reduce them. Nevertheless, ambiguity regarding the effects of resources slack stems from the variety of types of slack. In the perspective of the resource based view, a project can be viewed as a bundle of resources, and relationships may exist between these resources (Black & Boal, 1994). Thus, as Paleman and Vanacker (2015) point out slack in one type of resource may benefit or harm performance, depending on the level of other types of resource slack. Barney (1991) groups all resources into three categories: financial capital resources; human capital resources, and organizational capital resources. Financial capital resource slack encourages experimentation, allowing it to pursue new opportunities (March & Simon, 1963; Bourgeois, 1981; Zahra, 1991). Human capital resources slack—as opposed to financial slack—is highly idiosyncratic to context and more difficult to redeploy (Lecuona & Reitzig, 2014). Paleman and Vanacker (2015) propose an analysis grid distinguishing four bundles of slack resources that exist when considering both financial and human resource (HR) slack. “Some firms may experience parallel resource abundance, that is, having both financial and HR slack. Other firms may experience parallel resource constraints, that is, lacking both financial and HR slack. Firms may also be characterized by a pattern of selective resource constraints, which means that they are constrained in one resource but have slack in another” (2015: 821). It has been shown that HR slack generally decreases a firm’s performance (Lecuona & Reitzig, 2014) while financial slack improve performance. Take into account different types of slack appears relevant. According to Paleman and Vanacker (2015), combining constraints in one resource with slack in another resource, rather than experiencing constraints in multiple resources, may allow entrepreneurs to avoid the resource constraints trap. Therefore, constraints in certain resources can be compensated by abundance in others. How do these resources constraint and slack influence risk perception in project?

METHODOLOGY

The data for this study was obtained by means of a questionnaire distributed via an online platform. The potential respondents were the project managers from large public companies. We invited five companies to participate in the research project. We then sent the questionnaire to our contact in the company, who then distributed it to the project managers. 147 questionnaires were completed. The respondents were asked to select and describe a project they were working on and subsequently answer questions about the perceived risks and resource slack. Table 1 describes the sample.

Questionnaire items were measured using a 7-point Likert scale. Table 2 presents all variables and their measures. All the latent variables were operationalized through multi-item scales drawn from the literature: Risk measurements were adapted from those used by Benaroch et al. (2006).

Project slack was measured using a scale adapted from Nohria and Gulati (1996) (see table 2). We then utilize dummy variables to identify firms represented by the four bundles of slack resources. We identify firms as having financial (and human resource) slack (and constraint) when their score is above (and below) the median value. We then create the *Slack Variable* as a four level measure which is coded: 1. Parallel resource constraints; 2. Resource constraints in financial resources; 3. Resource constraints in human resources; 4. Parallel resource abundance.

Table 1: Sample description

	Frequency	%
Project information		
Project Type		
Transport	48	32.65
Infrastructure	12	8.16
Equipement	41	27.89
IT	46	31.29
Project budget		
Less than or equal to \$5 million	45	31.01
Between \$5 and \$10 million	23	15.19
Equal to or greater than \$10 million	79	53.80
Project size - i.e., the average number of internal and external individuals directly related to the project		
1 to 5 members	6	3.80
6 to 10 members	33	22.78
11 or more	89	75.42
Project phase		
Preparation	21	19.73
Implementation	29	14.29
Progress closure	4	2.72
Project completion	93	63.27

Table 2: Measurement instruments

<p>Human resource Slack</p> <p>If, for unforeseen reasons, 10% of your team's total working time is taken up with unrelated tasks, how much would this affect the project outcomes in the next period? 0. None; 1. Lower by 1 to 5%; 2. Lower by 6 to 10%; 3. Lower by 11 to 15%; 4. Lower by 16 to 20%; 5. Lower by 21 to 25%; 6. Lower by 26 to 30%; 7. Lower by more than 30%</p>
<p>Financial slack</p> <p>If, for unforeseen reasons, your project's annual operating budget is reduced by 10%, how much would this affect the project outcomes in the next period? 0. None; 1. Lower by 1 to 5%; 2. Lower by 6 to 10%; 3. Lower by 11 to 15%; 4. Lower by 16 to 20%; 5. Lower by 21 to 25%; 6. Lower by 26 to 30%; 7. Lower by more than 30%</p>
<p>Monetary risk (alpha, 0.70)</p> <p>In order to clarify the objectives, we have carried out some additional activities to those that were originally planned (reversed).</p> <p>The business opportunities are clearly related to the activities that we carry out (reversed).</p> <p>The project is necessary in order to realize expected benefits (reversed).</p> <p>It is quite possible to measure the expected outcomes and benefits (reversed).</p> <p>Processes to assess opportunities (or unexpected benefits) have been put in place (reversed).</p> <p>We have established indicators and measures to determine (or) assess project outcomes (reversed).</p> <p>We have key indicators for assessing business opportunities (reversed).</p>
<p>Competence risk (alpha=.88)</p> <p>All the team members have the required competencies (or) skills to carry out the project. (reversed)</p> <p>The team has experience with the technologies used for this project. (reversed)</p> <p>The success of this project will depend on the skills and experience of certain team members in particular (reversed)</p>
<p>Scope risk (alpha = 0,73)</p> <p>There are sufficient resources to cover all the business processes involved in the project (reversed).</p> <p>The project scope is clearly stated and defined in the project plan (reversed).</p> <p>The project deliverables are clearly understood by all the project team members (reversed).</p> <p>The activities that have been–or that will be–carried out are clearly defined and understood in the planning phase (reversed).</p> <p>The activities that we did or that we have to do include preparing a detailed budget plan (reversed).</p>
<p>Organisational support risk (alpha = 0.67)</p> <p>The project plan has been approved by all concerned parties (reversed).</p> <p>Changes in your organization can have unexpected effects on the project.</p> <p>The customer can ensure that the project will be a success (reversed).</p>
<p>Execution risk (alpha=0.79)</p> <p>The project management plan reflects best project management practices (reversed)</p> <p>A cost and contingencies estimate has been done (reversed)</p> <p>The quality management process for the project has been planned (reversed)</p> <p>Rapid and efficient processes have been put in place for decision making and problem solving (reversed)</p> <p>The project has emergency measures in place to deal with unforeseen events (reversed)</p>
<p>Project Stage</p> <p>1. Preparation; 2. Implementation; 3. Project closure; 4. Project completion</p>
<p>The size of the team – i.e., the average number of internal and external individuals directly related to the project – is: 1. 1 to 5 members; 2. 6 to 10 members; 3. 11 or more</p>

RESULTS

Table 3 shows the correlations and descriptive statistics for continuous variables used in our analysis.

Table 3: Descriptive statistics and correlation

	Mean	Std. dev.	1	2	3	4
1 Monetary risk	19.329	5.192				
2 Competence risk	5.715	2.402	0.021			
3 Scope risk	10.215	3.396	0.311*	0.535*		
4 Organisational support risk	8.462	2.395	0.382*	0.207*	0.459*	
5 Execution risk	12.880	5.111	0.752*	0.362*	0.685*	0.567*

* $p < 0.05$

Regressions models were performed with Perceived risks (Monetary risk, competence risk, scope risk, organizational support risk, execution risk) as dependent variables. The categorical slack variable (with four categories: 1. Parallel resource constraints; 2. Resource constraints in financial resources; 3. Resource constraints in human resources; 4. Parallel resource abundance) is introduced as independent variable. Project stage, project size, project type were introduced in the models as control variables. Because five organizations are involved, observations were selected such that group linkage may exist. To address this problem, the regression models incorporated the robust and cluster options available in Stata. The objective is to test the overall null hypothesis that the average of each risk perception is equal among the four bundles of slack resources. In order to clarify the existence of differences for each dependent variable according to the slack variable, we used the *pwcompare* command in Stata, after estimating each regression model (Mitchell, 2012). According to these tests presented in table 5, results find statistically significant differences in competence risk perception between project with parallel resource constraints and parallel resource abundance ($p < .05$) but not between projects having resource constraints in financial resources and resource constraints in human resources. Scope and execution risks reach the highest levels of perception when human resources are restricted. While the risk associated with organizational support is perceived to be highest when there are constraints on financial resources. Results in table 5 show that there are no differences in adjusted mean among the four bundles of slack resources.

DISCUSSION AND CONCLUSION

This research aims at understanding the subjective construction of risk. It shows that resource attribution can have an influence on risk perception in project. However, resource slack and constraint do not influence all kind of risk perception. In projects characterized by parallel resource abundance, risks are less perceived. Indeed, projects with larger slack resource endowments are more likely to have greater degrees of freedom. In this case, managers can be often inclined to focus their attention more on exploiting and leveraging their existing resource bundles. In projects with parallel resource abundance, project managers either probably focus more likely on traditional risk management tools—in turn less perceived risks level—, or either adopt more risky behavior. This result is consistent with previous studies that view slack as a buffer between organizations and contingencies (Moses, 1992). For instance, analyzing organizational slack, Litschert and Bonham (1978) proposed that organizational slack can minimize the negative effects of inconsistencies between environment and structure: the excess resources can be used to pay the price of the mismatch.

Table 5: Pairwise comparison of marginal linear predictions among the four bundles of slack resources

	Contrast ¹	Std. Err.	t
Monetary risk			
(Parallel resource constraints vs Resource constraints in financial resources)	-0.574	2.293	-0.25
(Parallel resource constraints vs Resource constraints in human resources)	-10.836	6.646	-1.63
(Parallel resource constraints vs Parallel resource abundance)	-1.52	1.201	-0.13
(Resource constraints in financial resources vs Resource constraints in human resources)	-10.261	6.302	-1.63
(Resource constraints in financial resources vs Parallel resource abundance)	0.422	2.441	0.17
(Resource constraints in human resources vs Parallel resource abundance)	10.684	6.263	1.71
Competence risk			
(Parallel resource constraints vs Resource constraints in financial resources)	0.474	1.016	0.47
(Parallel resource constraints vs Resource constraints in human resources)	1.676	1.544	1.09
(Parallel resource constraints vs Parallel resource abundance)	1.538	0.477	3.22*
(Resource constraints in financial resources vs Resource constraints in human resources)	1.202	2.295	0.52
(Resource constraints in financial resources vs Parallel resource abundance)	1.063	1.198	0.89
(Resource constraints in human resources vs Parallel resource abundance)	-0.138	1.514	-0.09
Scope risk			
(Parallel resource constraints vs Resource constraints in financial resources)	-1.159	0.704	-2.27*
(Parallel resource constraints vs Resource constraints in human resources)	-3.185	1.174	-2.71**
(Parallel resource constraints vs Parallel resource abundance)	-3.84	1.415	0.25
(Resource constraints in financial resources vs Resource constraints in human resources)	-1.585	1.171	1.35
(Resource constraints in financial resources vs Parallel resource abundance)	1.250	1.408	0.89
(Resource constraints in human resources vs Parallel resource abundance)	2.835	1.640	1.73†
Organisational support management risk			
(Parallel resource constraints vs Resource constraints in financial resources)	-2.351	0.310	-7.59***
(Parallel resource constraints vs Resource constraints in human resources)	2.677	0.505	5.31***
(Parallel resource constraints vs Parallel resource abundance)	-8.08	0.608	-1.13
(Resource constraints in financial resources vs Resource constraints in human resources)	4.761	0.503	9.47***
(Resource constraints in financial resources vs Parallel resource abundance)	1.266	0.605	2.12*
(Resource constraints in human resources vs Parallel resource abundance)	-3.479	0.704	-4.94***
Execution risk			
(Parallel resource constraints vs Resource constraints in financial resources)	-1.812	0.764	-2.37†
(Parallel resource constraints vs Resource constraints in human resources)	-11.265	7.089	-1.59
(Parallel resource constraints vs Parallel resource abundance)	1.086	0.934	1.16
(Resource constraints in financial resources vs Resource constraints in human resources)	-9.452	7.161	-1.32
(Resource constraints in financial resources vs Parallel resource abundance)	2.897	1.237	2.34†
(Resource constraints in human resources vs Parallel resource abundance)	12.351	7.089	1.74

† p < 0.10; *p < 0.05; **p < 0.01; ***p < 0.001

1. a positive value means that for (1) vs. (2) : (1) > (2) a negative value means that for (1) vs. (2) : (1) < (2)

By reducing risk level perception, slack may have a negative impact on project: abundance resources (having slack in financial and human resources) can maintain project managers in exploiting known risk management tools, rather than pursuing new options. Indeed, the resource constraints literature suggests that resource abundance is not necessarily beneficial (Garud & Karnoe, 2003). At the organization level, Paleman and Vanacker (2015) show that firms with resource constraints in one or multiple domains perform better than firms with parallel resource abundance.

Our results show that risks are more perceived when no slack does limit the traditional risk factors. Projects that experience resource constraints are therefore forced to seek alternative ways to manage risks. In this case, perceived risks are often higher and, as a result, project managers can engage more often in exploration to pursue new and more radical opportunities as one of the alternatives. Indeed, the resource constraints literature further posits that firms with fewer resources rather than more are likely to leverage their existing resources more efficiently (Baker & Nelson, 2005) this can be transcribed at the project level. Table 6 resumes the results and show that resource constraints

in either domain influence risk perception differently. Distinct bundles with resource constraints have their own effects on risks perception.

Table 6: Different bundles of slack resources and risk perception in project

		Financial slack	
		Low	High
Human Resource Slack	Low	<i>Parallel resource constraints</i> Competence risk	<i>Constraints in human resources</i> Scope risk Project execution risk <i>Competence risk</i>
	High	<i>Constraints in financial resources</i> Organizational support risk <i>Competence risk</i>	<i>Parallel resource abundance</i>

This research suggests some arenas for future research on the influence of excess resources in projects outcomes.

REFERENCES

- Adkins, P. S. (2005). *Organisational slack resources, the definitions and consequences for business flexibility and performance: an empirical investigation* (Doctoral dissertation, Aston University).
- Amabile, T. M., & Conti, R. (1999). Changes in the work environment for creativity during downsizing. *Academy of Management Journal*, 42(6), 630-640.
- Baker, T., & Nelson, R. E. (2005). Creating something from nothing: Resource construction through entrepreneurial bricolage. *Administrative science quarterly*, 50(3), 329-366.
- Benaroch, M., Lichtenstein, Y., & Robinson, K. (2006). Real options in information technology risk management: An empirical validation of risk-option relationships. *MIS Quarterly*, 827-864.
- Black, J. A., & Boal, K. B. (1994). Strategic resources: Traits, configurations and paths to sustainable competitive advantage. *Strategic management journal*, 15(S2), 131-148.
- Bourgeois, L. J. (1981). On the measurement of organizational slack. *Academy of Management review*, 6(1), 29-39.
- Chapman, R. J. (2001). The controlling influences on effective risk identification and assessment for construction design management. *International Journal of Project Management*, 19(3), 147-160.
- Cyert, R. M. & March, J. G. (1963). *A Behavioural Theory of the Firm*. Englewood Cliffs, NJ: Prentice- Hall.
- Ferrier, W. J. (2001). Navigating the competitive landscape: The drivers and consequences of competitive aggressiveness. *Academy of management journal*, 44(4), 858-877.
- Garud, R., & Karnøe, P. (2003). Bricolage versus breakthrough: distributed and embedded agency in technology entrepreneurship. *Research policy*, 32(2), 277-300.
- Kor, Y. Y., & Mahoney, J. T. (2004). Edith Penrose's (1959) contributions to the resource-based view of strategic management. *Journal of management studies*, 41(1), 183-191.

- Huchzermeier, A., & Loch, C. H. (2001). Project management under risk: Using the real options approach to evaluate flexibility in R... D. *Management Science*, 47(1), 85-101.
- Lecuona, J. R., & Reitzig, M. (2014). Knowledge worth having in 'excess': The value of tacit and firm-specific human resource slack. *Strategic Management Journal*, 35(7), 954-973.
- Litschert, R.J. & Bonham, T.W. (1978). A conceptual model of strategy formation. *Academy of Management Review*, 3(21), I-219.
- March, J. G., & Simon, H. A. (1993). *Organizations*, 2nd ed. Blackwell Publisher : cambridge, MA.
- Miller, K. D., & Leiblein, M. J. (1996). Corporate risk-return relations: Returns variability versus downside risk. *Academy of Management Journal*, 39(1), 91-122.
- Mitchell, M. (2012), *Interpreting and Visualizing Regression Models Using Stata*, Stata Press, College Station, TX.
- Moses, O. D. (1992). Organizational slack and risk-taking behaviour: tests of product pricing strategy. *Journal of Organizational Change Management*, 5(3), 38-54.
- Nohria, N., & Gulati, R. (1996). Is slack good or bad for innovation?. *Academy of management Journal*, 39(5), 1245-1264.
- Singh, J. V. (1986). Performance, slack, and risk taking in organizational decision making. *Academy of management Journal*, 29(3), 562-585.
- Sitkin, S. B., & Weingart, L. R. (1995). Determinants of risky decision-making behavior: A test of the mediating role of risk perceptions and propensity. *Academy of management Journal*, 38(6), 1573-1592.
- Sitkin, S. B., & Pablo, A. L. (1992). Reconceptualizing the determinants of risk behavior. *Academy of management review*, 17(1), 9-38.
- Thevendran, V., & Mawdesley, M. J. (2004). Perception of human risk factors in construction projects: an exploratory study. *International Journal of Project Management*, 22(2), 131-137.
- Thompson, V. (1969), *Bureaucracy and Innovation*, University of Alabama Press, Tuscaloosa, AL.
- Tversky, A., & Kahneman, D. (1975). Judgment under uncertainty: Heuristics and biases. In *Utility, probability, and human decision making* (pp. 141-162). Springer Netherlands.
- Wiseman, R. M., & Bromiley, P. (1996). Toward a model of risk in declining organizations: An empirical examination of risk, performance and decline. *Organization Science*, 7(5), 524-543.
- Woodman, R. W., Sawyer, J. E., & Griffin, R. W. (1993). Toward a theory of organizational creativity. *Academy of management review*, 18(2), 293-321.
- Zahra, S. A. (1991). Predictors and financial outcomes of corporate entrepreneurship: An exploratory study. *Journal of business venturing*, 6(4), 259-285.

IN-STORE SHOPPING CART ABANDONMENT: AN EXPLORATORY STUDY

Hilda Bongazana Dondolo
Tshwane University of Technology
South Africa

Nkosivile Welcome Madinga
Nelson Mandela Metropolitan University
South Africa

ABSTRACT

Shopping cart abandonment is pervasive and impacts profoundly on retail business profits. Generally, shopping cart abandonment presents problems for retailers. Research on in-store shopping cart abandonment has remained limited. In order to fill this gap in literature, the present study examines in-store shopping cart abandonment at retail stores by exploring factors believed to influence this shopping behaviour. From a sample of student population (n=165) an exploratory factor analysis using principal component analysis extraction and varimax rotation methods was undertaken to determine the underlying factors of in-store shopping cart abandonment. The factor analysis revealed a four factor structure: In-store shopping cart abandonment, Feelings about the wait, Opinions about the store and Unplanned behaviour. In order to determine if there were significant relationships among these factors, correlation analysis was conducted. The analysis revealed that Feelings about the wait was the only variable related to In-store shopping cart abandonment. Limitations of the findings are discussed and future research directions proposed.

Keywords: Shopping cart abandonment, perceived waiting time, store ambiance, impulse buying.

INTRODUCTION

The retail environment is fraught with many problems ranging from stock shrinkage attributed to theft and to stock spoilage and waste. One of the observed factors leading to spoilage and waste is shopping cart abandonment. Shopping carts transport shopping items to the tills. However, more often than not, certain items do not make their way to the tills, ending up abandoned in unusual and incorrect locations. The situation is even worse for perishable items that are removed from refrigerators and left in aisles where there are no refrigerators. Despite the pervasiveness of the practice, it is still a puzzle why past research fail to take cognisance of this prevalent shopping behaviour which impacts drastically on business profits. Considering that there are few studies conducted on off-line shopping cart abandonment, for a better understanding of this phenomenon, the present study draws upon literature on online shopping cart-abandonment and contextualise it to the offline shopping cart abandonment environment. Researchers studying online shopping cart abandonment have identified numerous factors that appear to result to such a practice. Price, time pressure, shoppers' financial status, privacy and security issues (Kukar-Kinney & Close, 2010), product risk, non-delivery risk, return policy (Moshrefjavadi, Dolatabadi, Nourbakhsh, Poursaeedi & Asadollahi, 2012) are all factors associated with online shopping cart abandonment.

Also, the present study will lean toward literature that generally focus on factors influencing consumers' shopping behaviours. This area of research informs us that consumers' decisions to patronise a store is a complex and dynamic one influenced by several of factors. Such factors include, but are by no means limited to perceived

waiting time, store ambiance, overcrowding, hedonic motivations, regret, impulse buying, price and social influence. Therefore, the aim of the present study is to examine a combination factors which are believed to contribute to this shopping behavior and thereby contributing to the much neglected yet important literature of in-store shopping cart abandonment.

In order to achieve the aim of this study, we examine how perceived waiting time, store ambiance, impulse buying, perceived crowding and regret influence in-store shopping cart abandonment.

LITERATURE REVIEW

By its very nature, shopping may evoke both negative and positive emotions. Past research indicate that lower prices, better service, better facilities, and well-designed store will evoke positive emotions while poorly designed store, unpleasant atmosphere and poor service may evoke negative emotions (Yoo, Park & MacInnis, 1998). Therefore, based on the situation, each shopping trip may yield different experiences for a consumer. According to Harrell, Hutt and Anderson (1980) any unpleasant shopping experience could have an effect on the evaluation of such shopping trip. Among such unpleasant shopping experiences are perceived crowding and perceived waiting time. According to Machleit, Eroglu and Mantel (2000) perceived crowding and perceived waiting time may elicit negative emotions. It is such negative feelings that are expected to drive consumers to a decision to abandon shopping carts. Li, Kim and Lee (2009) noted that when consumers experience negative emotions, they will spend less time in a store. The next section overviews perceived waiting time.

Perceived waiting time

Dabholkar and Bagozzi (2002) define perceived waiting time as “consumer’s perception of whether he or she will have to wait for a significantly longer time to use a particular service delivery option than to use an alternative option” (p. 189). Generally, research indicates that consumers do not like to wait. Perceived waiting time has been linked to various negative consequences and to whether consumers will continue patronising the store after such an experience. For instance, long waits have been shown to lead to impatient consumers (Parasuraman, Grewal, & Voss, 2002). Waiting times on queues to the till may also influence In-store shopping cart abandonment.

Regret

Landman (1993) noted that following a negative experience such as waiting for a service, consumers tend to regret the decision to visit the store. In their study, Comm and Palachek (1984) found that individual’s regret level affect both their waiting time and their shopping behaviour. In the same manner that regret is one of the important variables influencing waiting time, it is expected that those consumers who regret their choice of patronising the store will eventually abandon their shopping carts.

Store ambience

Baker, Grewal and Parasuraman (1994) refer to ambient factors as “non-visual, background conditions in the environment, including elements such as temperature, lighting, music and scent. Past research has observed an influence of ambient factors on shopping behaviours” (p.330). Pine and Gilmore (1998) noted that music, lighting, colour and aroma influence the consumers’ decisions to stay in a store. Morrison, Gan, Dubelaar and Oppewal (2011) supported this view and concluded that store atmosphere affects consumers’ emotional states such that those consumers who liked, for example, music played in the store may spend more time in a particular store (Turley & Milliman, 2000). Based on this background, it is believed that when consumers do not like the environmental conditions of the store, they may end up abandoning their shopping carts.

Perceived crowding

According to Bateson and Hui (1987) crowding is viewed as an unpleasant experience in shopping situations. Concerns about overcrowding in certain retail shops are common among consumers, and in many instances may constitute a central reason why consumers reduce their shopping time (Harrell *et al.*, 1980). To some consumers, retail crowding activates a state of unpleasantness and discomfort resulting to stress and loss of personal space (Stokols, 1972). Consequently, consumers who perceive that the store is crowded may become unhappy or irritated and thereby spend less time in the store (Li *et al.*, 2009). It is during this time we expect that consumers may abandon their shopping cart.

Impulse buying

Beatty and Ferrell (1998) described impulse buying as “unplanned behaviour entailing an irresistible urge to buy products that were not thought of before entering the store” (170). Such behaviour, as noted by Ajzen (2008), is often irrational and based on emotions. More often than not, consumers perform this unreflective behaviour when they are stressed out or in a depressed mood with the aim of comforting themselves with the purchase (Verplanken & Herabadi, 2001). For these reasons, we expect to see impulse buyers abandoning their shopping carts once they realise their purchase was not planned.

RESEARCH METHODOLOGY

Sample

In order to explore the factors influencing In-store shopping cart abandonment, data was collected from a convenience sample of students at a Western Cape Private college. For studies interested in understanding a particular behaviour or phenomenon with no intentions of generalising the findings, the use of student sample appear appropriate (Randall & Gibson, 1990). Previous studies (Li *et al.*, 2009; Kukar-Kinney & Close, 2010; Mehta, Sharma & Swami, 2013) interested in understanding consumer shopping behaviours, also used the student sample. In this study, students were given a self- completed questionnaire distributed in class. No incentives were given for completing the survey. Also, participants were assured of the anonymity of their responses.

Respondents’ demographic profile

There were 165 respondents who participated in this study. Of the 165, 41 percent were male and 59 percent were female. Thirty two percent of the respondents were 20 years old; 24 percent were 21 years old; 18 percent were 19 years old; 12 percent were 24 years old; 11 percent were 22 years old and 3 percent were 23 years old.

The questionnaire and data gathering

Data were gathered using a structured self-completed questionnaire. The store ambiance construct was measured by an instrument adapted from d'Astous (2000) study. To measure impulse buying, we adapted an instrument developed by Beatty and Ferrell (1998). The perceived crowding measure was based on the research conducted by Li *et al.*, (2009). The items for measuring regret and perceived waiting time were based on a study conducted by Voorhees, Baker, Bourdeau, Brocato and Cronin (2009). The questionnaire consisted of three sections A, B and C. Section A consisted of questions seeking some background information about the respondents. Section B contained questions related to In- store shopping cart abandonment and perceived waiting time. Section C contained items related to situational factors of shopping behaviour.

Data analysis

The data for this study was analysed using Statistical Package for Social Sciences (SPSS) version 24. In order to explore factors that might influence In-store shopping cart abandonment behavior, factor analysis was carried out.

RESULTS

Factor analysis

The aim of this study was to examine In-store shopping cart abandonment and the relationship with selected situational factors of shopping behaviour. In-store shopping cart abandonment has received little attention from researchers and thus there is no *a priori* theory about factors and their correlations. As such, exploratory factor analysis was used in the present study. A list of statements concerning shopping behaviours were provided to respondents to indicate on a five Likert-type scale their level of agreement and disagreement. The Kaiser-Meyer-Olkin (KMO) measure of sampling adequacy was undertaken. The KMO measure of sampling adequacy was 0.715 with chi square value of 1301.368 with 351 degrees of freedom and thus making it acceptable. To determine whether factor analysis was appropriate for the data set, the Bartlett's test of Sphericity was performed. The test returned a significant value ($p = 0.000$) suggesting suitability for factor analysis. Principal Axis with varimax rotation was used to determine the underlying factor structure. The factor structure produced eight dimensions with eigenvalues greater than 1.0 and accounted for 65.8% of the variance. All factor loadings above 0.50 were retained (Hair, Anderson, Tatham & Black, 1998). Those items that loaded on more than one factor were assigned to the factor where it loaded the highest. The communality values of the items of the variables were also computed. All the values were above the recommended value of 0.50 indicating that the items of the variables correlate with others (Fabrigar *et al.*, 1999). The communality values range from 0.598 to 0.827. Table 1 shows the eight factors with their item loadings, communalities, percentage variance explained and Cronbach alphas.

Table 1: Factor structure, factor loadings, communalities, percentage variance explained and Cronbach alpha

Dimension	Factor loading	Communality	Percentage variance explained	Cronbach alpha
Factor 1			9.36	0.713
Waiting at queues makes me feel irritated	0.781	0.765		
Waiting at queues makes me feel frustrated	0.634	0.670		
Waiting at queues makes me feel annoyed	0.579	0.618		
Visiting this store was a regrettable decision	0.530	0.687		
Factor 2			8.38	0.686
I made unplanned purchases	0.755	0.694		
I bought items in the shopping cart	0.731	0.735		
I bought things that I had not intended to purchase	0.718	0.632		
Factor 3			8.15	0.748
I often abandon the shopping cart	0.814	0.669		
I leave items in my shopping cart without buying them	0.795	0.625		
I place an item in the shopping cart but do not buy	0.766	0.688		
Factor 4			7.90	0.615
The wait to the tills queues was unacceptable	0.744	0.661		

The wait to the tills queues was long	0.700	0.675		
The wait to the tills queues was acceptable	0.548	0.687		
Factor 5			7.29	
There was bad smell in the store	0.749	0.653		
Music inside the store is too bad	0.712	0.721		
It was too hot inside the store	0.610	0.634		
Factor 6			7.10	
The wait to the tills queues was too short	0.845	0.760		
The wait to the tills queues was brief	0.725	0.709		
Factor 7			6.57	
The wait to the tills queues was lengthy	0.812	0.827		
The wait to the tills queues was unreasonable	0.542	0.712		
Factor 8			5.60	
The time I had to wait for at the queues was reasonable	0.675	0.598		
The time I had to wait for at the queues was acceptable	0.550	0.687		

The factors in the factor structure were then analysed for internal consistency using Cronbach alpha. Factors whose reliability values were less than 0.60 (Malhotra, 2007) were not considered for further analysis. Fabrigar, Wegener, MacCallum and Strahan (1999) argue that variables with low reliabilities should be avoided. Table 1 shows that the values of alpha ranged from 0.560 to 0.748. For internal consistency identification, only those factors with alpha values ranging from 0.615 to 0.748 were considered,

After removing factors with alpha values less than 0.60, four factors remained and were labelled according to collective names. Factor 1, with four items accounting for 9.3% of variance concerned feelings about the wait at queues. Item loadings for this dimension ranged from 0.530 to 0.781. This factor was labelled Feelings about the wait. Factor 2, describes situations where buying is unplanned and had three items accounting for 8.3% of variance. This dimension was labelled Unplanned buying. Item loadings for this dimension ranged from 0.781 to 0.755. Factor 3 deals with abandonment situations was labelled In- store shopping cart abandonment. The dimension had three items accounting for 8.1% of variance with item loadings ranging from 0.766 to 0.814. Factor 4 was labelled Opinions about the store. This dimension had three items relating to opinions about the store. The items accounted for 7.9% of variance with loadings ranging from 0.60 to 0.749.

Measurement instrument validity

After naming the factors, discriminant validity was assessed by the use of correlation matrix. According to Parasuraman *et al.*, (1993) discriminant validity refers to the “degree to which measures of theoretically unrelated constructs do not correlate highly with one another” (p.142). Table presents correlation matrix used to assess validity.

Table 2: Correlation matrix

	In- store shopping cart abandonment	Feelings about the wait	Opinions about the store	Unplanned buying
In-store shopping cart abandonment	1	0.240**	0.136	0.108
Feelings about the wait		1	0.398**	0.368**
Opinions about the store			1	0.211**
Unplanned buying				1

Significant at * $p < 0.05$; ** $p < 0.01$ (2-tailed)

The results indicate that In- store shopping cart abandonment and Feelings about the wait dimensions were positively and significantly related to each other ($r = 0.240, p < 0.01$). Concerning a relationship between Opinions about the store and In-store shopping cart abandon, this study found no significant relationship ($r = 0.136, p > 0.01$). Also, there was no significant relationship between Unplanned buying and In-store shopping cart abandonment ($r = 0.108, p > 0.01$). The Feelings about the wait and the Opinions about the store were also positively and significantly correlated to each other ($r = 0.398, p < 0.01$). There was a significant positive correlation between the Feelings about the store and Unplanned buying dimensions ($r = 0.368, p < 0.01$). Opinions about the store and Unplanned behaviour were also significantly correlated ($r = 0.211, p < 0.01$). All the values obtained when correlating the dimensions obtained from the factor structure analysis were relatively small, suggesting discriminant validity.

DISCUSSION OF FINDINGS AND MANAGERIAL IMPLICATIONS

The aim of the present study was to examine In-store shopping cart abandonment at retail stores by exploring factors believed to influence such a shopping behaviour. Exploratory factor analysis was conducted. The exploratory factor analysis suggest that Feelings about the wait, Opinions about the store and Unplanned buying might influence In-store shopping cart abandonment. Further analysis in the form of correlation analysis was performed to understand which of the identified variables are related. The results indicate a significant positive correlation between Feelings about the wait and In-store shopping cart abandonment. These results are expected. As we have expected, waiting times in long queues influences shopping cart abandonment. Our findings are consistent with what is known about the influence of waiting time on consumers' behaviour. Parasuraman et al (1994) observed that long waits in queues result in impatient consumers.

Quite contrary to our expectations, however, was to observe that there was no relationship between Unplanned buying and In-store shopping cart abandonment. Since Unplanned buying is an emotional act, we predicted that once consumers realise that their purchase was irrational (Ajzen, 2008), they will immediately abandon their shopping carts. However, the results of this study suggest that even impulse buyers' shopping carts do make their way to the tills. Perhaps the only concern for impulse buyers is the strong determination to satisfy their irresistible urge to buy when confronted with emotional issues such that shopping cart abandonment may not become a distant thought, but it might completely escape one's mind. Furthermore, the results of this study found no significant relationship between Opinions about the store and In-store shopping cart abandonment. Clearly, respondents of this study did not care as much as we expected about the environmental factors of the store. Thus, the smell in the store, the music inside the store and the temperature inside the store are not sufficient to drive the respondents of this study to abandon their shopping carts. Although the results of this study found no relationship between Opinions about the store and In-store shopping cart abandonment, we still believe that environmental factors might contribute to shopping cart abandonment. Therefore, retail stores should have proper working ventilation system. Based on the results of the present study, we suggest that retail managers reduce waiting time by having more tills installed in their environments. Further, we believe automated till systems might assist in reducing the abandonment levels of shopping carts.

LIMITATIONS AND FUTURE RESEARCH

Although the results of this study provide useful information to researchers and managers, the study provides avenues for additional research as it is important for retailers to understand why this behaviour occur and how to counteract it. First, exploratory factor analysis was used in the present study. The exploratory factor analysis suggest that Feelings about the wait, Opinions about the store and Unplanned buying might influence In-store shopping cart abandonment. However, we cannot rule out the existence of other factors. The factor analysis provided preliminary results. In view of the fact that we did not perform rigorous statistical analysis on the results, we urgently call on researchers interested in this severely neglected literature on In-store shopping cart abandonment, to go beyond a mere identification of factors influencing this prevalent and somewhat bewildering shopping behaviour and move quickly to extend in a more rigorous fashion the investigation by developing

theoretical frameworks and models. In this study a total of 165 students were used. This limits the generalisability of the findings. Future research should replicate the study with a different population group to ensure that results are generalizable. Although a sample size of 100 might be adequate, Fabrigar *et al.*, (1999) argue that larger sample sizes are preferred. Therefore, researchers are advised to use larger samples when studying this phenomenon.

REFERENCES

- Ajzen, I. (2008). Consumer attitudes and behavior. *Handbook of Consumer Psychology*, 1, 525-548.
- Baker, J., Grewal, D., & Parasuraman, A. (1994). The influence of store environment on quality inferences and store image. *Journal of the Academy of Marketing Science*, 22(4), 328-339.
- Bateson, J.E.G., & Hui, M.K.M. (1987). Testing a theory of crowding in the service experience. *Advances in Consumer Research*, 17, 866-873.
- Beatty, S.E., & Ferrell, M.E. (1998). Impulse buying: Modeling its precursors. *Journal of Retailing*, 74(2), 169-191.
- Comm, C., & Palachek, A.D. (1984). The effect of various waiting line times and regret levels on individual consumption time. *NA-Advances in Consumer Research*, 11, 41-45.
- Dabholkar, P.A., & Bagozzi, R.P. (2002). An attitudinal model of technology-based self-service: moderating effects of consumer traits and situational factors. *Journal of the Academy of Marketing Science*, 30(3), 184-201.
- d'Astous, A. (2000). Irritating aspects of the shopping environment. *Journal of Business Research*, 49(2), 149-156.
- Fabrigar, L.R., Wegener, D.T., MacCallum, R.C., & Strahan, E. J. (1999). Evaluating the use of exploratory factor analysis in psychological research. *Psychological Methods*, 4(3), 272-299.
- Hair, J.F., Anderson, R.E., Tatham, R.L., & Black, W.C. (1998). *Multivariate data analysis*. Englewood Cliff: New Jersey.
- Harrell, G.D., Hutt, M.D. & Anderson, J.C. (1980). Path analysis of buyer behavior under conditions of crowding. *Journal of Marketing Research*, 17, 45-51.
- Kukar-Kinney, M., & Close, A.G. (2010). The determinants of consumers' online shopping cart abandonment. *Journal of the Academy of Marketing Science*, 38(2), 240-250.
- Landman, J. (1993). *Regret: The persistence of the possible*. New York, NY: Oxford University Press.
- Li, J.G.T., Kim, J.O., & Lee, S.Y. (2009). An empirical examination of perceived retail crowding, emotions, and retail outcomes. *The Service Industries Journal*, 29(5), 635-652.
- Machleit, K.A., Eroglu, S.A., & Mantel, S. P. (2000). Perceived retail crowding and shopping satisfaction: what modifies this relationship?. *Journal of Consumer Psychology*, 9(1), 29-42.
- Malhotra, N.K. (2007). *Marketing research: an applied orientation*. 7th ed. Upper Saddle River: Prentice-Hall.
- Mehta, R., Sharma, N.K., & Swami, S. (2013). A typology of Indian hypermarket shoppers based on shopping motivation. *International Journal of Retail & Distribution Management*, 40-55.
- Morrison, M., Gan, S., Dubelaar, C., & Oppewal, H. (2011). In-store music and aroma influences on shopper behavior and satisfaction. *Journal of Business Research*, 64(6), 558-564.

- Moshrefjavadi, M.H., Dolatabadi, H.R., Nourbakhsh, M., Poursaeedi, A., & Asadollahi, A. (2012). An analysis of factors affecting on online shopping behavior of consumers. *International Journal of Marketing Studies*, 4(5), 69-81.
- Parasuraman, A., Berry, L.L., & Zeithaml, V.A. (1993). More on improving service quality measurement. *Journal of Retailing*, 69(1), 140-147.
- Pine, B.J., & Gilmore, J.H. (1998). Welcome to the experience economy. *Harvard Business Review*, 76(4), 97-105.
- Randall, D.M., & Gibson, A.M. (1990). Methodology in business ethics research: A review and critical assessment. *Journal of Business Ethics*, 9(6), 457-471.
- Stokols, D. (1972). On the distinction between density and crowding: Some implications for further research. *Psychological Review*, 79, 275-278.
- Turley, L.W., & Milliman, R.E. (2000). Atmospheric effects on shopping behavior: a review of the experimental evidence. *Journal of Business Research*, 49(2), 193-211.
- Verplanken, B., & Herabadi, A. (2001). Individual differences in impulse buying tendency: feeling and no thinking. *European Journal of Perspective*, 15, 71-83.
- Voorhees, C.M., Baker, J., Bourdeau, B.L., Brocato, E.D., & Cronin, J.J. (2009). It depends moderating the relationships among perceived waiting time, anger, and regret. *Journal of Service Research*, 12(2), 138-155.
- Yoo, C., Park, J., & MacInnis, D.J. (1998). Effects of store characteristics and in-store emotional experiences on store attitude. *Journal of Business Research*, 42(3), 253-263.

AN ANALYSIS OF ENTERPRISE RISK MANAGEMENT AND CORPORATE GOVERNANCE IN ZIMBABWE'S BANKING SECTOR

**Zenzo Lusaba Dube, Elias Muzinda and Ntobeko Ndlovu
National University of Science and Technology, Zimbabwe**

ABSTRACT

In the years 2003-2004 Zimbabwe's financial sector experienced corporate malfeasances largely due to poor corporate governance and risk management practices. As a redress, the Reserve Bank of Zimbabwe (RBZ) instructed the banking sector to observe sound Enterprise Risk Management (ERM) principles. The RBZ sought to instil good corporate governance (CG) practices across boards. The study involved the RBZ, twenty banking institutions and twelve Asset Management Companies (AMCs). It sought to assess ERM and CG behavioural practices, perceptions. Good CG and sound ERM are vital if financial institutions are to weather the present cash crisis haemorrhaging Zimbabwe's economy.

Keywords: ERM, Corporate Governance, RBZ, Banks, AMCs.

INTRODUCTION

The 2003-04 banking crisis was perhaps the single most significant event which changed both the course and nature of Zimbabwe's post-independence banking sector. The banking sector witnessed poor corporate governance practices largely due to individualistic maximisation behaviours. A number of banks were placed under curator-ship (Fourth Quarter Monetary Policy Statement, 2004). According to the RBZ the key causes of the crisis were liquidity and solvency problems underpinned by other factors such as inadequate risk management systems, poor corporate governance, diversion from core business to speculative activities, rapid expansion, creative accounting, overstatement of capital, high levels of non-performing loans and unsustainable earnings. Since then the Zimbabwean Monetary Authorities' efforts have centred on a series of initiatives towards strengthening the CG systems in banks by enhancing discipline across boards. In mid-2010 the then RBZ Governor pointed out that banking institutions were expected to manage risk in a more comprehensive, coordinated and integrated way across the entire business spectrum as opposed to focusing only on regulatory compliance. In recent years, a number of big corporate scandals have highlighted the need for an enterprise-wide integrated and systematic approach to risk management (Ratnatuga and Alam, 2008). This approach is referred to as enterprise risk management. ERM is a combination of risk management and internal controls designed to provide an integrated approach to the identification, assessment, monitoring, and management of risks across an organization. ERM concepts represent a movement away from distinct or 'silo' approaches to managing different risks within an organization to an approach that is more comprehensive and coherent (ibid). The study analyses ERM and CG behavioural practices in the Zimbabwean financial sector. Zimbabwe is a multi-currency regime. It became multi-currency after the hyperinflation which decimated its local currency which was abandoned in 2009 in favour of the multi-currency system. The United States Dollar dominates this basket of multi-currencies. The dollarization stabilized inflation to single digits in the years 2009-2017. In 2017 Zimbabwe experienced a deepening cash crisis emanating from the shortage of forex. One can posit that sound ERM and good CG practices are now a must if the banks are to weather the current cash crisis storm.

LITERATURE REVIEW

ERM approach constitutes best practices in risk management. ERM has gained prominence for managing risk and providing competitive advantage in the face of myriad challenges facing business organisations (Stroh, 2005). ERM simply aims to identify and prevent obstacles, and exploit opportunities for achieving the objectives of an entity; therefore it works for any entity, be it commercial, not-for-profit or governmental, big or small. The ERM concept raises risk management to another level, by linking the entire organization and all categories of risk. It responds to the needs of governing bodies and management to understand an organization's portfolio of top risk exposures which might affect the organization's objectives. Its implementation enhances an organisation's consciousness in terms of risk and risk management. The ERM approach also emphasizes a top-down, holistic view of the inventory of key risk exposures potentially affecting an enterprise's ability to achieve its objectives. Boards and senior executives seek to obtain knowledge of these risks with the goal of preserving and enhancing stakeholder value. A successful risk management approach should be proportionate to the level of risk (as related to the size, nature and complexity of the organization), comprehensive in its scope, integrated with organizational activities and processes, dynamic, allowing for continuous updating, monitoring and improvement, and able to respond to changing circumstances.

Terzi and Posta (2010) posit that ERM offers a coherent methodology for risk management, and protects and adds value to the organization and its stakeholders. They summarized the benefits of ERM: ERM makes risk management an integral part of achieving organizational objectives;

- a. Improves planning, programming and decision-making and their implementation by ensuring a comprehensive and structured understanding of objectives, activities and related risks and opportunities;
- b. Allows management to identify and prioritize key risks using an organization-wide portfolio view of risks;
- c. Identifies common and cross-cutting risks and improves cross-departmental communication and discussions; and
- d. Reinforces the accountability and integrated internal control framework (ibid).
- e. ERM makes risk management an integral part of achieving organizational objectives; thus helps ensure that those objectives are achieved;
- f. Reinforces the accountability and integrated internal control framework (ibid).

Enterprise Risk Management Frameworks

A sizeable number of risk frameworks and statements have been published by professional bodies across the Globe. This study briefly covers the two following frameworks as alluded by The Institute of Management Accountants (IMA) (2006). These are namely The Combined Code and The King (ii) (2002) now The King (iii) Report (2009).

The Combined Code and Turnbull Guidance

In the United Kingdom, the Financial Reporting Council published the Combined Code on Corporate Governance (the Code) in 2010. The Code states that the role of the board is to provide a framework of effective control so that risk is assessed and managed. The board is also required to review the effectiveness of controls, including all controls over financial, operational, and compliance areas as well as risk management systems.

King (ii) now King (iii) Report

The King Report on Corporate Governance for South Africa (King ii Report) was published in 2002 to promote good CG practices. This report has five sections which are namely board and directors, risk management, internal audit,

integrated sustainability reporting and accounting and auditing. According to King, the board is responsible for the risk management process and its effectiveness. The board should *inter alia* set risk strategy policies, assess the risk process and exposures, such as physical and operational risks, human resource risks, technology risks, business continuity and disaster recovery, credit and market risks, and compliance risks. It should also review the risk management process and significant risks facing the company and be responsible for risk management disclosures. The Fourth Report on CG in South Africa was published on the 1st of November 2016. This Report is known as the King IV Report on Corporate Governance for South Africa.

THE THEORITICAL FRAMEWORK: ENTERPRISE RISK MANAGEMENT AND CORPORATE GOVERNANCE

The ERM and CG framework, responsibilities, and communications overlap, as one process affects the other. Everyone involved has important ERM and governance roles to play as they endeavour to more closely align their companies' governance with their ERM processes. In order to explain the linkage between CG and ERM, the IMA(2004) developed an ERM and CG framework that consists of four components, namely the corporate stakeholders, the governance "umbrella" provided by the board of directors, risk management and assurance. It indicated that the board should involve itself in the ERM process by providing direction, authority, and oversight to management. CG and shareholder value are the key drivers in the ERM process. ERM is believed to provide a solid foundation upon which companies can enhance CG and deliver greater shareholder value (Bowling and Rieger, 2005).

The primary stage of ERM focuses on CG and compliance (Shimpi, 2005). CG is vital for effective ERM and none of the ERM components can be achieved without CG compliance (Rosen and Zenios, 2001). CG normalises the relations between shareholders, board of directors, top management, and stakeholders. ERM is the framework where corporations optimize the risk/return relationships for their businesses. This optimization is achieved through alignment of corporate strategic goals and risk appetite. At the operational level, the alignment guides virtually all activities conducted by the corporation. Specific risks are identified and measured. They are prioritized and integrated by recognizing the inter-relations and relative influences. Risk management strategies are developed for the portfolio of risks. The effects are assessed and communicated. In this way, ERM reduces the waste of resources caused by inadequate communication and cooperation under a silo-based risk management framework.

An ERM process identifies, assesses, evaluates, and manages priority risks to the organization. The Internal Control-Integrated Framework's (COSO) (2004) objectives suggest a holistic approach as the best method for ensuring compliance and a positive impact on shareholder value. A strategic focus on enterprise-wide risk leads to market advantage and firms that engage in ERM are able to better understand the aggregate risk inherent in different business activities. This provides them with a more objective basis for resource allocation, thus improving capital efficiency and return on equity. Organizations with a wide range of investment opportunities are likely to benefit from being able to select investments based on a more accurate risk-adjusted rate than was available under the traditional risk management approach.

METHODOLOGY

The target population was the RBZ, 20 banking institutions and 12 AMCs. A total of 35 questionnaires were distributed as follows; 20 to the banking institutions, 12 to AMCs and 3 to the RBZ. The questions sought the financial sectors' views, perceptions on ERM and its perceived value in maintaining financial stability.

The questionnaires were for the risk managers. The interviews were with the directors (executive and non-executive) of banks and AMCs. Fourteen were held.

RESULTS

Table 1 is the response rate for the questionnaire:

Table 1: Questionnaire Response Rate

Name of respondent(s)	Sent	Responses	Percentage (%)
RBZ	3	3	100
Banking Institutions	20	16	80.00
AMCs	12	7	58.33
Total	35	26	74.28

Source: Fieldwork Data

The Questionnaire

Fifty three percent of all respondents were below the age of 30 years, 28% were aged between 31 and 40 years and the remaining 19% were +40. The Basel Committee posits that experienced staff is key to a successful implementation of The Basel II. A greater proportion (65.39%) had 6 to 10 years' experience in risk management whereas with the RBZ, 7.69% had more than 12 years' experience in banking supervision. Of those with degrees, 50% had Master's and 30% had diplomas. 90 % of the respondents affirmed that ERM is part of their current or future business process—41% of respondents noted that organization has a well-defined ERM program. The majority of respondents indicated that their organizations have implemented processes around tasks that were relatively “easy” — conducting formal, corporate-wide risk assessments, aggregating risks at the corporate level, developing corporate-wide risk policies and procedures, and developing an enterprise risk dashboard/reporting process.

Sizeable proportions (50%) of financial institutions were of the view that ERM is relevant to the Zimbabwean financial sector, 30% saw ERM as irrelevant, and 20% were not sure. Twenty percent were of the belief that ERM can be introduced without any major hindrances. A closer look reveals that a lot needs to be done in terms technological requirements, human expertise and RBZ's capacity. The drivers for implementing ERM were unearthed as follows:

- a. To meet with regulatory requirements;
- b. ERM as a better management practice;
- c. ERM as a response to the banking crisis; and
- d. To satisfy their Board of Directors
- e. As per the Audit Committees' requests.

Protection against loss and damage to reputation was seen as the most important potential benefit of an ERM strategy. Respondents cited more efficient allocation of capital as a clear benefit of ERM, while containing losses was seen as another advantage. Top down enthusiasm and enforcement, risk culture training & awareness and having enterprise risk data were seen as the most critical factors for a successful ERM program, followed by ease of use of, and familiarity with ERM tools. Less than half (45%) of the organizations surveyed posited that the prevalent culture was “entirely” or “significantly” taken into account when implementing ERM.

Nearly half of respondents used a combination of the various implementation tools available. Ninety percent of ERM programs at the participating institutions covered credit and market risk. Operational risk, which has become a focus largely because of Basel II, was also included in nearly all of the ERM programs, indicating that it has now become almost universally accepted as a fundamental risk type to manage. Sixty two percent concurred that ERM

should be an embedded cost and should not be different from costs associated with regulatory compliance. 77% of the participating institutions reported that their boards of directors had overall oversight responsibility for the management and control of risk. As part of this responsibility, their board of directors have approved a clearly-stated risk framework and associated risk policies, which has been communicated throughout the organization. Three quarters noted that the board of directors approved the institution's risk management policy and reviewed regular risk reports from management. Sixty-three percent of the institutions had a formal, approved statement of their risk appetite.

Seventy seven percentage of the respondents indicated that their boards have formally assigned risk oversight responsibility to a board committee. The remainder of the respondents noted that such delegation has not been formalized by their boards. For those boards that have assigned formal risk oversight to a committee, 65% have assigned that task to the audit committee. Others have assigned risk oversight to the board's Executive Committee (17%) or to separate Risk Committees (15%). Of those boards that are delegating risk oversight formally to a committee, 52% have delineated explicit responsibilities for risk oversight in the respective committee's charter. Three-quarters of institutions reported risk information to the board of directors on risk concentrations, operational failures and stress testing, while two-thirds reported on new and emerging risks and on utilization versus limits. Respondents stated that quarterly and annually are the most common cycles for updating the board with risk management information.

The Interviews

The directors held the view that Zimbabwe's financial sector should at best be at par with international best practices in terms of risk management. They noted ERM played a critical role in profits, margins and cash flow objectives. They added that appropriately applied ERM principles helped avoid duplication of efforts in mitigating risks. The directors, however, expressed concern over the lack of risk data and the understanding of the ERM. It was also noted that ERM and CG could steer financial institutions towards stability. Good CG equals good business. A holistic ERM anchored by good CG is in reality the ultimate utopia. These sentiments were drawn from the espoused views of the interviews.

OBSERVATIONS AND DISCUSSIONS

The recent placement of some of the local banks under curatorship has nudged the directors' boards to review their risk management practices. The study revealed that the majority of financial institutions reviewed do have formalized ERM approaches and methodologies in place. The successful implementation of the ERM strategy within the financial sector relies on sound CG practices. CG is vital for effective ERM. CG normalises the relations between shareholders, board of directors, top management, and stakeholders. The adoption and successful implementation of ERM are not only driven by CG and compliance, but also driven by good business practices, value creation, and survival. ERM can increase firm value by lowering the firm's cost of capital, which is achieved by reducing the cost of debt and / or equity. The cost of capital can further be reduced by lowering external monitoring costs and by increasing the potential of a higher credit rating from rating agencies. Moreover, it was indicated that ERM creates value by reducing management's risk by decreasing the associated deadweight loss, while aligning manager's and shareholder's interest.

A large majority of the directors felt ERM provided significant value in specific areas such as improved understanding of risks and controls, increased ability to escalate critical issues to senior management, enhanced risk culture and better balance of risks and rewards, and improved perceptions by the regulators. ERM aids in minimising possible financial losses that might be encountered.

CONCLUSION

ERM should be an integral part of financial institutions. ERM has the ability to assist financial institutions in ensuring compliance with applicable laws and regulations. It provides support to an institution's CG processes, and thereby

increases investors', stakeholders' and regulators' confidence. ERM enables sound rapid response to multi-faceted risks. This is now a necessity for banks in Zimbabwe if they are to survive the current cash crisis storm debilitating the country

IMPLICATIONS FOR POLICY

Policy makers are urged to embrace ERM and CG. Sound ERM and good CG signal good institutional practices which in turn, can result in efficient boards.

REFERENCES

Bowling, DM., & Rieger, L. (2005a). Success factors for implementing enterprise risk management. *Bank Accounting and Finance* 8(3), 21-26.

Bowling, DM & Rieger, L. (2005b). Making sense of COSO's new framework for enterprise risk management. *Bank Accounting and Finance* 8(2), 29-34.

Committee of Sponsoring Organizations of the Treadway Commission. (2004). Enterprise Risk Management — Integrated Framework Executive Summary. http://www.coso.org/documents/coso_erm_executivesummary.pdf Accessed 10 August 2016.

Institute of Risk Management South Africa. 2003. Code of Practice. The Institute of Risk Management South Africa. <http://www.irmsa.org.za/page/intro>. Accessed 10 August 2016.

King Report ii. (2002). King Report on Corporate Governance in South Africa. Institute of Directors. Johannesburg. http://www.ecgi.org/codes/documents/king_i_sa.pdf Accessed 10 August 2016.

King Report iii. (2009). King code of governance for South Africa 2009. <http://www.ecgi.org/codes/documents/king3.pdf>. Accessed 10 August 2016.

Manab AN, Hussin M.R & Kassim, I., (2006). Enterprise-Wide Risk Management (EWRM) Implementation and Compliance among Public Listed Companies (PLC) in Malaysia. *Proceedings of the Asia-Pacific Risk and Insurance Association (APRIA) 10th Annual Conference, 30 July-2 August 2006, Meiji University, Tokyo, Japan.*

Rosen, D & Zenios, SA. (2006). Enterprise-wide asset and liability management: issues, institutions, and models. In Zenios, SA and Ziemba WT, *Asset and Liability Management*. Elsevier, Amsterdam

Shimpi, P. (2005). ERM from compliance to value. *Financial Executive* 21, 52-55.

Stroh, PJ, (2005). Enterprise risk management: At United health Group. *Strategic Finance* 27, 35.

Terzi C, Posta, I, (2010). Review of Enterprise Risk Management In The United Nations System. Benchmarking Framework Joint Inspection Unit. Geneva 2010 United Nations IU/REP/2010/4. <https://www.unjiu.org/en/reportsnotes/archive/Review%20of%20enterprise%20risk%20managemen%20in%20the%20United%20Nations%20system.pdf>. Accessed 15 September 2016

ORGANIZATIONAL IDENTITY AND STRATEGIC DECISIONS IN A CHANGING BUSINESS ENVIRONMENT

Koushik Dutta
Indian Institute of Management, India

ABSTRACT

This research contributes to extant literature on organizational identity by establishing organizational identity as an antecedent to the creation and maintenance of competitive advantage of an organization in a competitive marketplace. The study, using the concept of embedded case studies, has focused on two airlines in the Indian civil aviation sector – SpiceJet, and Kingfisher Airlines. The study reveals that organizational identity plays a key role in the effectiveness of a firm’s strategic and operational capabilities. A dysfunctional identity of a firm results in its having lowered awareness of market and competitors, critical business parameters, resource building measures, and flexibility in identity building.

Keywords: organizational identity, competitive dynamics, sense making, strategic decisions, market orientation.

INTRODUCTION

The concept of organizational identity has emerged during the last few decades as an important dimension in understanding firms and their stakeholder interactions (Huemer, 2012). Organizational identity has been defined to comprise those attributes that members consider to be fundamental to and uniquely descriptive of the organization and as being central, distinctive and enduring about an organization for its members (Albert and Whetton, 1985), a particular instance of a managed collective identity based upon organizational membership and identification (Moufahim et al., 2015), with the ability of holding the members of the organization together and attracting support (Morrill et al., 2003), and to connect different experiences and reduce fragmentation in feelings and thinking (Kärreman and Alvesson, 2001).

This research contributes to extant literature on organizational identity by establishing organizational identity as an antecedent to the creation and maintenance of competitive advantage of an organization in a competitive marketplace. The questions which drive this research are as follows: Does the self-identity of an organization impact its competitive advantage in a contested terrain? If it does so, then what is the nature of this relationship? What are the causal factors inherent in the relationship? Answers to these questions would greatly benefit researchers and practitioners who are linked through their work and practices to the concepts of competitive advantage and hypercompetitive marketplaces.

I have adopted the case study method, and have studied the Indian domestic aviation sector which had transformed from a regulated market to a competitive market after the government of India announced a blue sky policy in 1990 and liberalized the domestic aviation sector. The article is interdisciplinary in nature, and combines theories from strategic management theory, and psychological and cognitive theories.

LITERATURE REVIEW

Livengood and Reger (2010) have connected the fields of organizational identity and competitive dynamics, and have studied how organizational identity translates into the cognitive, affective, and psychological antecedent to competitive action and reaction.

Competitive dynamics views the competitive landscape of an industry as a dynamic and interactive field (Chen and Miller, 1994, 2012, 2015; Kilduff et al., 2010; Livengood and Reger, 2010; Marcel et al., 2010), as against the static models put forward by industrial economists (Bain, 1951; Porter, 1980, 1985).

A distinct research theme in competitive dynamics which has emerged over the years is that of competitive perception (Chen and Miller, 2012). This may be traced back to the views of Staw (1991) that psychological theories can be used to explain organizational action and that macro actions may be micro behavior in disguise in a situation where individuals are able to influence organizational action. Hambrick and Mason (1984) have put forward the upper echelons theory according to which executives' experiences, values, and personalities greatly influence their interpretations of the situations they face and, in turn, affect their choices. Dutton and Duncan (1987) have presented a model according to which decision makers interpret strategic issues based on three critical events: activation, assessment of urgency and assessments of feasibility. Ocasio (1997) has developed a model of firm behavior according to which specific situations, and firm resources, rules and relationships influence the attention of decision makers on issues which in turn influences behavior of the firm.

If one were to adhere to the view that organizations behave like individuals, and that organizational behavior and actions may partly be explained by psychological theory, then organizations will have distinct perceptions of markets, competitors, and events which will shape its actions in varying extent. Therefore, organizational perceptions become a key focus of competitive dynamics study, as evidenced by extant work (Staw et al., 1981; Reger and Huff, 1993; Tsai et al., 2011; Chen and Miller, 2012). Subjective perceptions of decision makers influence their view of competitive environment and competing firms, and differences in cognitive framework of decision makers cause firms to react differently to external stimuli (Fiol, 1989; Barr et al., 1992; Marcel et al. 2010; Mattsson et al., 2015).

Livengood and Reger (2010) have introduced the concept of identity domain which explains the focus of the top management team in an organization on certain competitive arena which relates closely to its identity in the marketplace, and have used the awareness-motivation-capabilities (AMC) framework developed by Chen (1996) which states that a competitor will not be able to respond to an action unless it is aware of the action, motivated to react, and capable of responding. Firms tend to compete in certain areas in which they perceive their identity to be at stake (Livengood and Reger, 2010) and take actions to defend this 'identity domain'. However, competitors operating in the environment may have differing perceptions of the market, competitors, and competitiveness, and such asymmetry in perceptions lead to fundamentally different strategies and business models (Chen and Miller, 2012).

Huemer (2012) posits that the emergence of organizational identity often depends on relationships, and relates the emergence and construction of identities to sensemaking processes – how others make sense of the actions of the organization and how these others influence the focal organization's understanding of itself.

The concept of sense making was introduced to organizational studies by Weick (1969). Weick (1969) defines sensemaking as the process through which we define our identity, continuously shape experience into meaningful patterns, and which enables us to move forward in action despite contextual ambiguity. Weick (1995) states that sensemaking is a matter of identity: it is who we understand ourselves to be in relation to the world around us.

In the words of Karl E. Weick:

There are many definitions of sensemaking; for me it is the transformation of raw experience into intelligible world views. It's a bit like what mapmakers do when they try to make sense of an unfamiliar place by capturing it on paper. But the crucial point in cartography is that there is no one best map of a particular terrain.

According to Daft and Weick (1984), organizations are vast, fragmented, and multidimensional, and therefore possess a high level of system complexity. Decision makers in an organization are required to interpret events surrounding the organization, by translating the events, bringing out meaning, and developing mental models. The process of interpretation depends on the decision maker's belief of the analyzability of environmental events. If the organization assumes that external events are concrete and open to measurement and hard analysis, then the organization will employ linear thinking and logic to seek out solution. However, when an organization assumes that the external environment is unanalyzable, the interpretation process may be less linear and more improvisational, and may lead to inventing and shaping an environment, and soft, qualitative data, along with judgment and intuition play a large role in the interpretation process.

Weick et al. (2005) posit that sensemaking and organization constitute one another, and that an organization emerges from an ongoing process in which people organize to make sense of equivocal inputs and enact that sense back into the world to make it more orderly.

The concept of sensemaking relates to individuals, and also to organizations. Decision makers respond to changes in the environment based on how they make sense of strategic issues. Such sensemaking is linked to the systemic effects of two contextual variables – the organization's belief structure and its resources. Decision makers attempt to interpret the issue urgency and feasibility of taking action, with both variables being critical in leading to a decision on action in response to the issue. The perception of urgency may arise from time pressure, visibility of the issue, attributions of responsibilities, and causal analysis. Assessment of feasibility depends on the perceived issue understanding – the perception that decision makers, with some effort, could identify the means for solving the issue, and perceived issue capability – the perception that the means for resolving the issue are available and accessible (Dutton and Duncan, 1987).

Managers use framing—the cognitive sensemaking of events, objects, and issues—when they make decisions (Reger et al., 1994), and cognitive inertia may result if existing frames need to be changed. This may be all the more pronounced when existing identities need to accommodate identity changes, and such needed change may face strong resistance as organizational identities are core, central, and enduring. Reger et al. (1994) defines identity gap as the cognitive distance between the perception of the current and ideal identities.

Various studies have found that market orientation provides a firm with competitive advantage (Hult and Ketchen, 2001; Dobni and Luffman, 2003; Morgan et al., 2009). Organizational identities influence the perception of the organization with respect to intensity of competition, competitors, and competitor moves in a hyperactive marketplace.

THE INDIAN AVIATION SECTOR

The Indian aviation sector had its origin in 1912 when the first domestic route was opened between New Delhi and Karachi. Air India was started by Tata Sons, a private business conglomerate, in 1932. India obtained independence from British rule in 1947, and government of India acquired 49% stake in the airline the next year. In 1953, the government exercised its option to purchase a majority stake in the carrier and established Air India International Limited, from which was created two state-owned airlines – Air India, for international travel, and Indian Airlines, for domestic travel.

The Government adopted an open-sky policy in 1990, and as part of this policy adoption ended the monopoly of Air India and Indian Airlines in 1994. Private operators were allowed to operate air transport services in the domestic sector in which foreign direct investment up to 49% of equity and non-resident Indian stake up to 100% were permitted. Several private airlines entered the sector, but very few managed to survive. Nevertheless, the steady growth of the Indian economy influenced the entry of new players after 2003.

SpiceJet

SpiceJet was incorporated in 2006, and the analysis of SpiceJet covers the period from FY 2006-07 to FY 2014-15. The airlines changed hands twice. While the company was started by Ajay Singh, management control passed on to Kalanithi Maran in 2009-10 with KAL Airways Private Limited, promoted by him, acquiring majority stake in SpiceJet.

During 2014-15 the company ran into severe financial crisis with the company struggling to pay outstanding dues and the flights being grounded. The Director General of Civil Aviation (DGCA) was forced to take regulatory action. During that year there was a stake sale and management control passed back to Ajay Singh. Six months after taking charge of SpiceJet from Kalanithi Maran, the airline's new chairman, Ajay Singh, scripted a turnaround. His restructuring plan focused on improving the airline's performance, regaining customer confidence and boosting the morale of employees.

For the quarter ended June 2015, the airline posted a net profit of Rs 780 mn., its highest ever, owing to lower fuel prices, improved fleet utilisation and renegotiation of contracts. For the year-ago period, it had reported a loss of Rs 1240 mn. SpiceJet clocked profits in three consecutive quarters in 2015.

Kingfisher Airlines

Kingfisher Airlines was established by Vijay Mallya in 2003, commenced operations in 2005 and was shut down in 2012. The analysis of Kingfisher covers the period from FY 2006-07 to FY 2012-13.

Kingfisher was very aggressive with its international expansion, launching long-haul as well as short-haul flights. It must be noted that the merger of Kingfisher with Air Deccan enabled the former to fly overseas, as a government regulation known as the 5/20 rule stipulated that only those Indian aviation companies would be permitted to have international routes if they operated for a minimum of 5 years in the domestic sector and had a minimum of 20 aircraft. Kingfisher had commenced operations in 2005, and the airline was merged with Air Deccan in 2007, thus allowing the former to claim overseas flying rights within two years. The share of Kingfisher's revenue from international operations increased from 1.94% in 2007-08 to 25% in 2011-12, despite the airline suffering mounting losses during the period.

Acute financial problems led to the shutdown of its international operations in 2011-12, in the face of adverse stakeholder actions in the form of legal notices from banks, suspension of air operator's license by DGCA, suspension from IATA's settlement programme, stoppage of work by a section of employees, and attachment of accounts and sources of revenue by tax authorities. The Enforcement Directorate attached specific assets of Vijay Mallya on alleged money laundering charges.

Vijay Mallya fled the country on 1st March 2016, evading summons from the Directorate. Mallya's passport was revoked by the Government of India, a non-bailable arrest warrant was issued against Mallya, and the Supreme Court of India issued notice to Mallya and the defunct Kingfisher airlines on the basis of a contempt petition moved by the consortium of lender, to whom Kingfisher owed over Rs. 90,000 mn. for non-disclosure of assets (Business Standard [B.S.], 25 July 2016).

METHODS

This study is based on qualitative analysis and the case study method has been adopted which, according to Yin (2003), is the preferred research strategy when the investigator has little control over events, the research questions are more exploratory / explanatory in nature, and the focus is on a contemporary phenomenon within some real life context.

The study, using the concept of embedded case studies (Yin 2003), has focused on two airlines in the Indian civil aviation sector – SpiceJet, and Kingfisher Airlines.

The aviation sector in India, after the opening up of the skies through government legislature in 1990, represents the complexities inherent in a dynamic competitive environment. In such an environment, when events and actions unfold at a fast pace, a player in the game needs to be on alert at all times, alive to changes in the regulatory and economic environment, shifts in consumer preference, fluctuations in resource availability and cost, progress of competitors and competitor moves, entry of new players, and disruptive new technologies.

Content analysis has been carried out on the section 'management discussion and analysis' of the annual reports of the respective airlines – SpiceJet (2006-07 to 2013-14) and Kingfisher Airlines (2006-07 to 2012-13) comprising 15 documents, and on select news articles in Business Standard during these periods.

The objective of the content analysis has been to identify, for each of the two airlines, perceptions of critical variables with respect to the environment, industry, competition, and competitors, and to identify opportunities and crisis confronting each airline, and strategic and tactical actions.

FINDINGS

Awareness of Market and Competitors

During the period under review, SpiceJet maintained a positive view on the market growth rate while acknowledging that the competition was intense and increasing. It was highly aware of the nuances of the competitive market and competitor moves, evidenced by the fact that Spicejet annual reports carried detailed analysis of market trends, market shares, and major competitor actions.

The section on management discussion and analysis in SpiceJet's annual report for 2009-10 has the following statement:

The month of May 2009 witnessed a major strategic shift in the domestic industry with the introduction of the Low-Fare service 'Jet Konnect' by Jet Airways. By end of FY 2009-10, the Jet Konnect service was more than two-thirds of the seats deployed by Jet Airways. A similar shift of capacity from Kingfisher to Kingfisher Red was seen during this period with Kingfisher Red service accounting for more than two-thirds of the seat capacity deployed by the airline. These large-scale capacity conversions from Premium service to low-fare offerings seemed to vindicate the low-fare business model adopted by SpiceJet. By the end of FY 2009-10, it is estimated that more than two-thirds of the capacity deployed in the domestic market was a low cost and low-fare offering.

During the period under review, Kingfisher's view of the domestic market was mostly positive, seeing the Indian aviation market as having high long term potential. It viewed the Indian economy as exhibiting robust growth, resulting in continuous growth in the domestic aviation market, despite the international aviation market slowing down. It was mostly non-committal about the intensity of domestic competition or competitors, though it expressed the view that the market suffered from excess capacity. It was mostly silent about competition, except in 2007-08 when it felt the market was getting competitive because of low pricing policies of domestic airlines and because of international airlines expanding operations in India.

Focus on the Business Model and Critical Business Parameters

SpiceJet identified itself as a low cost carrier (LCC) model, enhancing regional connectivity with new routes and aircraft, and using its limited international operations to connect international travellers to the domestic network. Spice Jet showed full faith in the LCC model, and viewed the market as comprising two strategic groups – the full service airlines and the LCC, and in a scenario where low pricing and price warfare were the norms, the full service airlines losing out to the low cost carriers.

SpiceJet's self-image was in terms of the latter group as evidenced by the following quote from the 2009-10 annual report (this self-image being reflected in the annual accounts of other years too):

The share of the LCC's in this traffic increased from 45.61% during 2007-08 to 46.59% during 2008-09. In fact, for the last 4 months of the year, Low Fare Carriers carried as much traffic as the

Full Service Carriers. This trend is very significant for SpiceJet as it clearly indicates that our product and service is being increasingly accepted by the consumers. This also shows an increasing acceptance of the Low Cost Airlines by business and corporate travelers. Observing SpiceJet results, all full service airlines have started deploying significant capacity to the economy model. While this adds to the capacity in the low fare sector, their cost of operation continues to be that of a Full Service Carrier. This latest trend in the industry, however, seems to validate the low fare model that we believe in.

Kingfisher viewed itself as an international airline, and its action during the period under review provide evidence that it failed to match capabilities to aspirations. Driven by a single focus on going international, it lost its market orientation along the way and failed to link strategic objectives to operational performance.

The share of revenue from international operations increased over a four year period from 1.94% in 2007-08 to 25% in 2011-12. During the same period domestic market share declined from 26.7% to 15.6%. During its entire history of operations Kingfisher airlines have never made a profit.

The Kingfisher business model changed several times. When the airline commenced operations, it had a single-class configuration and had only economy class seats. However, after a year it introduced the business class. It merged with Air Deccan in 2007 and developed a three brand strategy comprising Kingfisher First (premium business class), Kingfisher Class (premium economy class), and Kingfisher Red (low fare basic class and formerly Air Deccan, acquired in 2007). Kingfisher exited the low-cost model in 2011-12 and initiated a phased transition to the full-service model.

Kingfisher initiated a route rationalization programme in 2008-09 to maximize operational synergy and save costs (annual report 2008-09), reduced domestic capacity by over 20%, and in the same year launched international operations. During 2009-10 there was a further drop in domestic capacity, by 17%, while the same year witnessed further expansion in Kingfisher's international operations through introduction of new wide body routes to Hong Kong, Singapore and narrow body routes to Dubai, Bangkok and Dhaka.

Kingfisher made a statement in 2011 that its focus was more on increasing its domestic presence and network as the domestic passenger numbers were set to increase, and the carrier had no major plans for international expansion. (Kingfisher shifts focus to domestic sector 19.2.2011, B.S.). The airline collapsed soon afterwards.

Focus on Resources and Resource Building Measures

During 2014-15 SpiceJet went through a period of crisis during which fleet and network had shrunk, market shares were down, lessors were demanding back aircraft for non-payment of lease rentals, and service providers and oil companies had suspended credit lines seeking payment of outstanding dues (SpiceJet's revival has lessons for Air India 8.7.2015, B.S.). With a change in management with the erstwhile taking back control, SpiceJet scripted one of the most successful turnaround stories in the country. The airline reduced debt, consolidated finances and systematically began expanding fleet and network. For the quarter October-December 2016, SpiceJet reported its highest quarterly profit of Rs. 2380 mn., compared to a loss of Rs. 2750 mn. in the corresponding one a year ago.

A fast turnaround like the one achieved by SpiceJet can be possibly only if the structure, systems and processes in the organization support and enhance each other, i.e., if the organization has strategic fit. As discussed previously, SpiceJet identified itself as a LCC, and was unwavering in its focus on the low cost business model in the domestic aviation sector.

Right from inception, Kingfisher airlines was focused on being an international airliner, an identity which remained fixed during the years it was operational despite two of its three brands being in the LCC segment. According to Giriprakash (2014), Vijay Mallya acquired the LCC Air Deccan to fulfill his overseas dreams. Government of India had a rule (named the 5/20 rule) which required domestic carriers to have at least five aircrafts and twenty years of flying experience in order to fly international routes. Air Deccan was purchased in 2007, without even a regular due diligence, and Kingfisher was merged with it as the new entity satisfied the 5/20 rule.

During an interview, Capt. G.R.Gopinath who had sold Air Deccan to Mallya, stated the following:

Low-cost aviation business was treated as a step-child. I was telling Mallya that it is now his child and there should be equal treatment. Post the merger, whenever there was an Air Deccan and Kingfisher flight at almost the same time-slots, a decision was taken to do away with the Air Deccan flight in the hope that the passengers will graduate to Kingfisher full-service. But just the opposite happened. They went to other LCC.

In this perspective it must be noted that the share of revenue from international operations increased over a four year period from 1.94% in 2007-08 to 25% in 2011-12. During the same period domestic market share declined from 26.7% to 15.6%. During its entire history of operations Kingfisher airlines have never made a profit.

Flexibility in Identity Building

SpiceJet always advertised itself as an airline that provides “safe, value-for-money, comfortable and hassle-free air travel” (annual report 2006-07). However, it subsequently realized that the Indian consumer was slowly evolving, and becoming more demanding, and the airline moved away from a pure market driven price point strategy to offering unique brand offerings, putting forward the brand message “Get more when you fly SpiceJet” (annual report 2009-10). The rebranding exercise continued and in 2014-15 advertised itself as an airline which was youthful and fun to be associated with.

To quote from the SpiceJet annual report 2014-15:

We started the journey with the mission to fulfill everyone’s dream of flying, to ensure ‘flying for everyone’. We transformed from affordable flying to - touching the hearts of millions and have now embarked into a yet another journey of being a youth-friendly airline that brings the fun, the anticipation, the hotness; in other words the more ‘spice’ into flying. And so we evolved into an airline which is ‘Red. Hot. Spicy’. This evolution is a progression. We remain genuine, courteous and cordial and are now more friendly and young in spirit. We are bright and cheerful as ever. We have extended the same tone of voice to every aspect about the airline now, including innovative product offerings.

The Kingfisher annual reports show no evidence of such branding exercise.

DISCUSSION

The aviation sector in India, after the opening up of the skies through government legislature in 1990, represents the complexities inherent in a dynamic and competitive environment. In such an environment, when events and actions unfold at a fast pace, a player in the game needs to be on alert at all times, alive to changes in the regulatory and economic environment, shifts in consumer preference, fluctuations in resource availability and cost, progress of competitors and competitor moves, entry of new players, and disruptive new technologies.

The study reveals that organizational identity plays a key role in the effectiveness of a firm’s strategic and operational capabilities. Placed against the AMC framework (Chen, 1996; Livengood & Reger, 2010), the actions of the two airlines show divergent paths in terms of awareness of market and competition, motivation, development of capabilities, and performance, as shown in Table 1.

Table 1: Comparison of the two airlines against the AMC framework

Airline	Identity	Awareness	Motivation	Capability	Net Effect
SpiceJet	Low Cost Carrier	High level of awareness of competitor moves	To be the most profitable low cost carrier in the market	High capability to compete within chosen domain	A highly competitive and capable player in the competitive Indian aviation market
Kingfisher	International airline	Greater focus on the international sector than on the domestic market	To be a success story in the international aviation market	Divergence between aspirations and actions led to low operational capability	A business failure

Organizational identities are constructed through an iterative process of sense making and sense giving, and a competitive environment with fast changing events and actions necessitate organizations not just to have a clear sense of identity closely aligned to the market and its business model, but also the flexibility to bring about changes in the identity if the situation so demands.

Future research could focus on further exploring the dynamics involving organization identities and dynamic capabilities, sensemaking and sensegiving leading to formation of organization identities, and resulting systems, practices, and routines giving rise to strategic fit.

REFERENCES

- Albert, S., & Whetten, D.A. (1985). Organizational identity. In L. L. Cummings, & B. M. Staw (Eds.), *Research in organizational behaviour*, 7, 263–295. Greenwich, CT:JAI.
- Bain, J.S. (1951). Relation of profit rate of industry concentration: American manufacturing, 1936-1940. *Quarterly Journal of Economics*, 65, 293 – 324.
- Barr, P.S., Stimpert, J.L., & Huff, A.S. (1992). Cognitive Change, Strategic Action, and Organizational Renewal. *Strategic Management Journal*, 13, 15-36.
- Chen, M.J. (1996). Competitor analysis and inter-firm rivalry: Towards a theoretical Integration. *Academy of Management Review*, 21, 100–134.
- Chen, M.J., & Miller, D. (1994). Competitive attack, retaliation and performance: an expectancy-valence framework. *Strategic Management Journal* 1, 85-102.
- Chen, M.J., & Miller, D. (2012). Competitive Dynamics: Themes, Trends, and a Prospective Research Platform. *The Academy of Management Annals*, 6, 135–210.
- Chen, M.J., & Miller, D. (2015) Reconceptualizing competitive dynamics: a multidimensional framework. *Strategic Management Journal*, 4, 1-41.
- Daft, R.L., & Weick, K.E. (1984). Toward a model of organizations as interpretation systems. *Academy of Management Review*, 9, 284–295.
- Dobni, C.B., & Luffman, G. (2003). Determining the scope and impact of market orientation profiles on strategy implementation and performance. *Strategic Management Journal*, 24, 577–585.
- Dutton, J.E., & Duncan, R.B. (1987). The creation of momentum for change through the process of strategic issue diagnosis. *Strategic Management Journal*, 8, 279-295.
- Fiol, C.M. (2001). Revisiting an identity-based view of sustainable competitive advantage. *Journal of Management*, 27, 691–699.
- Giriprakash, K. (2014). *The Vijay Mallya Story*. Penguin Books Ltd.
- Hambrick, D.C., & Mason, P.A. (1984). Upper Echelons: The Organization as a Reflection of Its Top Managers. *Academy of Management Review*, 9: 193-206.
- Huemer, L. (2012). Organizational identities in networks: Sense-giving and sense-taking in the salmon farming industry. *The IMP Journal*, 6, 240-253.
- Hult, G.T., & Ketchen, D.J. Jr. (2001). Does market orientation matter? A test of the relationship betweenpositional advantage and performance. *Strategic Management Journal*, 22, 899–906.
- Kingfisher shifts focus to domestic sector. (2011, February 19). *Business Standard*, p.5.
- Kärreman, D., & Alvesson, M. (2001). Making Newsmakers: Conversational Identity at Work. *Organization Studies*, 22, 59–89.
- Kilduff, G.J., Elfenbein, H.A., & Staw, B.M. (2010). The psychology of rivalry: a relationally dependent analysis of competition. *Academy of Management Journal*, 53, 943–969.

- Livengood, R.S., & Reger, R.K. (2010). That's our turf! Identity domains and competitive Dynamics. *Academy of Management Review*, 35, 48–66.
- Mattsson, L.G., Corsaro, D.R.C. (2015) Sense-making in business markets – the interplay between cognition, action and outcomes. *Industrial Marketing Management*, 48, 4-11.
- Marcel, J.J., Barr, P.S. & Duhaime, I.M. (2010) The influence of executive cognition on competitive dynamics. *Strategic Management Journal*, 32, 115-138.
- Morgan, N.A., Vorhies, D.W., & Mason, C.H. (2009). Market orientation, marketing capabilities, and firm performance. *Strategic Management Journal*, 30, 909 – 920.
- Morrill, C., Zald, M.N., & Rao, H. (2003) Covert political conflict in organizations: Challenges from below. *Annual Review of Sociology*, 29, 391–415.
- Moufahim, M., Reedy, P., & Humphreys, M. (2015). The Vlaams Belang: The Rhetoric of Organizational Identity. *Organization Studies*, 36, 91–111.
- Ocasio, W. (1997). Towards an attention-based view of the firm. *Strategic Management Journal*, 18, 187–206.
- Porter, M.E. (1980). *Competitive Strategy. Techniques for Analyzing Industries and Competitors*. New York: Free Press.
- Porter, M.E. (1985). *Competitive Advantage*. New York: Free Press.
- Reger, R.K., & Huff, A.S. (1993). Strategic groups: a cognitive perspective. *Strategic Management Journal*, 14, 103-124.
- Reger, R.K., Gustafson, L.T., Demarie, S.M., & Mullane, J.V. (1994). Reframing the organization: Why implementing total quality is easier said than done. *Academy of Management Review*, 19, 565–584.
- Staw, B.M., Sandelands, L.E. & Dutton, J.E. (1981) Threat-rigidity effects in organizational behavior: a multilevel analysis. *Administrative Science Quarterly*, 26, 501-524.
- Staw, B.M. (1991). Dressing up like an organization: when psychological theories can explain organizational action. *Journal of Management*. 1, 805-819.
- SpiceJet's revival has lessons for Air India. (2015, July 8). *Business Standard*, p. 6.
- Tsai, W., Su, K.H., & Chen, M.J. (2011). Seeing through the eyes of a rival: competitor acumen based on rival-centric perceptions. *Academy of Management Journal*, 54:761–778.
- Weick, K.E. (1969). *The Social Psychology of Organizing*. Reading, MA: Addison-Wesley.
- Weick, K.E. (1995). *Sensemaking in organizations*. Thousand Oaks, CA: Sage Publications.
- Weick, K.E., Sutcliffe, K.M., & Obstfeld, D. (2005). Organizing and the process of sensemaking. *Organization Science*, 16, 409–421.
- Yin, R.K. (2003). *Case Study Research – Design and Methods* 3rd.ed. SAGE Publications.

THE IMPACT OF SOCIO PROFESSIONAL CATEGORY OF THE CONSUMERS ON THE ACCEPTANCE LEVEL TOWARDS ISLAMIC BANKING WINDOW

Nabila El jed

Manouba University, Tunisia

Kaouther Znaidi

University of Hail, Kingdom of Saudi Arabia

Chokri El Fidha

**Laboratory ERMA Tunis El Manar University & ESSEC Business School
Tunis University, Tunisia**

ABSTRACT

Recently, Islamic banks have been presented as an alternative to conventional Banks. Indeed, Islamic banks have proved their worth during the 2009 crisis. They are known like an ethical bank. In Tunisia we have only three Islamic banks. Even the conventional banks are interested to offer Islamic banking products and services; we called Islamic Banking window. This paper aims to determine the level of acceptance of Islamic banking window on Tunisian consumers and the impact of the social professional category on it.

In this respect, we administered a questionnaire to a sample size of 120 respondents from Tunis City. The data were processed by SPSS 21. The results showed that the majority of the respondents have a lack of knowledge of the Islamic banking products. The majority of the respondents don't see any differences between the product name of conventional and Islamic banking products. The acceptance level of an Islamic banking product offered by a conventional bank is very satisfying. 53% of the respondents are certain to purchase an Islamic banking product from a conventional bank and 42% are not sure. Only 5% refused.

Keywords: Islamic banks, Islamic banking windows, social professional category, acceptance level.

INTRODUCTION

The Islamic banking is an alternative of conventional banking. The management of the activities of the Islamic banks has to be compliant with the Sharia (Islamic teaching). The concept of "Islamic Banking" is defined as the conduct of banking operations in consonance with Islamic teachings. Visser (2013) enumerate the main principles of Islamic banking activities comprise: the prohibition of usury (*riba*) in all forms of transaction, undertaking business and trade activities on the basis of fair and legitimate profit. The prohibition of haram activities like alcohol, guns, porc business... The prohibition of (Gharar and Maysir) risky or uncertain business like gambling. The principle of profit and lost share; Islam encourages Muslims to engage in the transaction that based on profit and loss sharing (PLS). The backup assets principle; any transaction is based on a tangible assets. This principles are adopted by Islamic banks and the ¹ sharia Board is responsible to make sure that are respected.

Islamic banking in Tunisia is recent. The sector accounts three banks. The principles ones are: Zitouna Bank and El Baraka Bank. In 2010 the first Islamic bank was Zitouna Bank holds only 2.2% of total bank assets. While El Baraka (ex BEST Bank established since 1983) was an off shore and became onshore since 2013. The third one is El Wifack International Bank established in 2015. All together, accounting for 7% of the Tunisian

banking market. While the Islamic banking in Tunisia is modest but he have significant growth potential, with an evolution which reached an annual average of 23%, during the period 2010-2015. That's why there is a promulgation of new laws encourage the conventional Banks to offer Islamic products and services.

In this context, we conducted our study. The acceptance level of Islamic banking products offered by an¹ Islamic window.

This paper is organized into four sections. Section 1 contains a literature review on Islamic banking adoption and the impact of socio- demographic factors on them. Section 2 presents the research methodology adopted in this study. In section 3 presents the results. Finally the section 4 is reserved for practical implications.

LITERATURE REVIEW

Patronizing Islamic Banks

The majority of researches on Islamic banking are concerned with the consumer awareness and adoption of Islamic banking products and services. There is no consensus in literature on Islamic banking adoption and selection criteria. The results are different from researcher to another across the world.

In Jordan, Erol and El Bdour (1989) and Erol et al. (1990) were the pioneers to study the adoption of Islamic banking. The sample was composed of conventional and Islamic banking customers. The results found that the three most important factors that determine their adoption process were: the provision of a fast and efficient service, bank's reputation and image and confidentiality.

While in Bahrain, Metawa and Almossawi (1998) focused their study only on Bahraini Islamic Banks customers. They found that Islamic principles as the most important factor in patronizing Islamic banks. The second important factor was the characteristics of the banks, followed by the influence of family and friends and convenience of location. The study shows that socio-demographic factors such as age, income and education were important criteria related to Islamic banking adoption.

In Kuwait, Othman and Owen (2001, 2002) conducted studies on adoption of Islamic Banking. They found that cultural and religious factors were identified as the most influential ones. In-line with the findings of previous researchers, Wakhid and Efrita (2007) in Indonesia found that states religious factor as the key factor that influences patronizing Islamic banking.

In Malaysia, Asyraf and Nurdianawati (2006), found among the common factors used to measure customers' selection criteria are cost and benefits of products offered, service delivery (fast and efficient), confidentiality, size and reputation of the bank, convenience (location and ample parking space), friends and families and friendliness and competency of bank staff. Additionally, the religious issue is also perceived as one of the important criteria to be considered for the selection of Islamic banking services.

In Tunisia, recently the study of consumer behavior toward Islamic banking has received some attention. A list of factors have been found as significant in the adoption of Islamic Banks like, religiosity, information about Islamic banking, bank's Sharia compliance, competitive rates, bank image, quality of products and their compatibility with the customers' values, lifestyle and financial needs (Chebab & Zribi, 2012; Ajili & Ben Garra, 2013; Thomson Reuters, 2013; Kaabachi & Obeid, 2014; Slimene et al. 2014; Obeid & Kaabachi (2016) found the significant effect of religiosity, amount of information, relative advantage, and compatibility on consumers' intentions to use Islamic banking services.

¹ Islamic window: a conventional bank who offer Islamic financing products and services.

Socio-demographic Factors and Islamic Banking

Few studies that are concerned with the examining of the relationship between consumers' socio-demographic variables and their attitudes towards Islamic banking (Gait and Worthington 2008). In Egypt, Hegazy (1995) was the pioneer who compared the demographic profiles two banks: Islamic Bank and conventional Bank. The outcomes showed that 98.8% of the Islamic bank's customers were Muslims married with children, while 32.4 % of the conventional bank's customers were Christians and 54.3 % were Muslims. This suggested that the choice of an Islamic bank is based, in part, on a religious motivation.

In Bahrain, Metawa and Almosawi (1998) studied the relationship between socio-demographic factors and the customer usage of Islamic bank products and services. They found a significant relationship between customer age and Islamic bank products such as the usage of current accounts and ATM cards. In addition, there was a significant relationship between customers' income, and customers' level of education and the use of current accounts and investment accounts. They consider the maintenance and the update of the socio demographic data of the Islamic banks' customers; is the key factor to formulate appropriate marketing strategies.

In Qatar, Metwally (2002) studied the role of socio-economic and demographic characteristics in the process of bank selection. The outcomes showed that females, the elderly and state workers preferred to trait with Islamic banks over conventional banks, as did those with relatively low incomes and a moderate level of education. In contrast, conventional banks were preferred by young, well educated working as professionals or highly-paid state workers, with foreign conventional banks.

In Malaysia, Zainuddin, and al (2004) studied the different perceptions of users and non-users of Islamic banking services. They found that most Islamic bank users were older than thirty with relatively stable family incomes. On the other hand, most non-users were single, aged less than thirty years with low incomes. In Turkey, Okumus (2005) studied the relationship between customer satisfaction with Islamic banks and socio-demographic factors such as gender, age, level of education and income. He found that there is no significant relationship between degree of satisfaction and socio-demographic components of the respondents.

In Bangladesh, Khan and Hassan (2008), found that majority of users of Islamic bank products are influenced frequently by age (25-35), education (high level) and income level (high level). In Pakistan, Ahmad and al (2011) attempted to identify perception and preference of Islamic banking products and services among bank customers (Islamic and conventional) by focusing on their demographic differences. The results show that, male customers prefer Islamic banking services while female customers' preference is more toward conventional banks. In addition, young customers (18-24) prefer the use of conventional banking products while the older (24-35) prefer the Islamic banking services.

In Malaysia, Amin (2012) studied the perceptions of customers about Islamic automobile financing by considering their demographic characteristics. The main result of the study revealed that although significant differences exist on gender, income, education and respondents' usage of Islamic automobile financing, but there was no significant difference in age with awareness and usage of this Islamic banking product among Malaysian bank customers.

In Tunisia, Ltifi and al (2015) studied the moderator role of age and gender in the selection of Islamic Banks. They found, women are more sensitive to the choice of Islamic banks than men. The form of service delivery, the level of trust and the financial institution's compliance with the "sharia" influence women to choose this bank more than men. This encourages advising Islamic financial institutions to adopt gender as one of the main criteria for segmentation and classification of its clients. In addition, the outcomes showed that, the under-35 group has a greater propensity to choose its Islamic bank on the basis of perceived quality of service, confidence in the financial institution and its compliance with the "sharia" Than the group of more than 35 years. The form of service delivery, the level of trust and the financial institution's compliance with the "Shari'a" influence young consumers to choose this form of banks more than older consumers.

METHODOLOGY

Sample

We limited ourselves to 120 people, after the selection and elimination of failing questionnaires and to have an exhaustive, credible result, we retained 100 observations.

They are customers of banks, mainly conventional banks. The sample was almost evenly distributed among men 54 and women 46. The majority has a bank account and a minority of 10 think they have them in the nearest months. 42 have been bank clients for more than 7 years and almost 1/5 have opened a bank account for less than a year. We summarize the profile of our respondents in the table below:

Table 1: Profile of the sample

Variables	Frequency	Valid percentage%
Gender		
Male	54	54%
Female	46	46%
Age		
25-34	57	57%
35- 44	43	43%
² SPC		
Employee	62	62%
Senior	32	32%
Profession	6	6%
Income		
Less than 500DT	6	6%
Between 500-1000DT	51	5%
More than 1000DT	43	43%

The questionnaire design

We administered the questionnaire directly by adopting the face-to-face method. The structured questionnaire was designed in consideration to respond to the main question of the research. Our questionnaire is structured as follow:

- The profile of the respondent: Gender, age, SPC, income.
- The Knowledge of the Islamic products: Murabaha, Musharaka, Mudharaba, Al Salam, Ijara, Istisn'a, Sukuk.
- the Perception of the Islamic banking product in comparison with the conventional ones: differences name of product, types of credit ...
- The Intention of adherence to purchase an Islamic banking product from a conventional Bank.

Results

The results of the survey show that there is a lack of knowledge of Islamic banking products. Indeed, apart from Murabaha known by 34%, the remainder of the products is very weakly known as indicated in Table 2 below. The majority of the respondents ignore the Islamic banking products.

² SPC : social Professional category.

Table 2: The knowledge of Islamic banking products

	Frequency	Valid percentage %
Murabaha	34	34%
Musharaka	13	13%
Mudharaba	6	6%
Al Salam	6	6%
Ijara	13	13%
Istisna'a	6	6%
Sukuk	22	22%
Total	100	100%

To understand the perception of Islamic banking product, we ask the respondents about the difference of the name of Islamic banking products and conventional ones. Is there any difference? In the same time we measured the impact of the PSC on the answer.

Table 3: The degree of difference between the name of conventional and Islamic banking products cross the SPC :cross tabulation

			Professional social category			Total
			Employee	Senior	Profession	
Product Name	No difference	frequency	29	18	0	47
		% included in the SPC	46,8%	56,3%	,0%	47,0%
		% of total	29%	18%	,0%	47,0%
	little difference	frequency	28	14	6	48
		% included in the SPC	45,2%	43,8%	100,0%	48,0%
		% of total	28,0%	14,0%	,0%	48,0%
	Big difference	frequency	5	0	0	5
		% included in SPC	8,1%	,0%	,0%	5,0%
		% of total	5,0%	,0%	,0%	5,0%
Total		frequency	62	32	6	100
		% included in the SPC	100,0%	100,0%	100,0%	100,0%
		% of total	62 ,0%	32,0%	6,0%	100,0%

We found that the majority of the interviewees didn't discern any differences between the name of Islamic banking products and conventional ones (47% detect no differences and 48% little differences). Only 5% discern a big difference between them.

The chi-square test confirms the existence of a significant relationship between the socio-professional category and the degree of difference between the name of the conventional banking product and the name of the Islamic banking product with a confidence interval of 3% $K^2 = 0.039 < 0.050$.

To know more about the perception of Islamic banking products; we ask about the perception of degree of differences between the type of conventional bank credit and the type of Islamic banking credit product. The results are crossed with SPC.

Table 4: Cross-tabulation Types of credits cross Socio-professional category

			Socio-professional category			Total
			Employee	Senior	Profession	
Types of credits	No difference	frequency	24	24	0	48
		% included in SPC	38,7%	75,0%	,0%	48,0%
		% of total	24,0%	24,0%	,0%	48,0%
	little differences	frequency	5	1	0	6
		% included in SPC	8,1%	3,1%	,0%	6,0%
		% of total	5,0%	1,0%	,0%	6,0%
	Medium Differences	frequency	21	7	0	28
		% included in SPC	33,9%	21,9%	,0%	28,0%
		% of total	21,0%	7,0%	,0%	28,0%
	Big differences	frequency	12	0	0	12
		% included in SPC	19,4%	,0%	,0%	12,0%
		% of total	12,0%	,0%	,0%	12,0%
	Very big differences	frequency	0	0	6	6
		% included in SPC	,0%	,0%	100,0%	6,0%
		% du total	,0%	,0%	6,0%	6,0%
Total		frequency	62	32	6	100
		% included in SPC	100,0%	100,0%	100,0%	100,0%
		% of total	62,0%	32,0%	6,0%	100,0%

The chi-square test confirms the existence of a significant relationship between the socio-professional category and the degree of the difference between the type of conventional bank credit and the type of Islamic banking credit product with a confidence interval of 0% of $K^2 = 0.000 < 0.050$.

Finally, we measured the level of acceptance of an Islamic banking product from a conventional bank crossed with SPC.

Table 4: The possibility of purchasing an Islamic product from a conventional Bank cross SPC

Cross Tabulation						
			Socio-Professional Category (SPC)			Total
			Employee	Senior	Profession	
If a conventional bank offers an Islamic product. Do you buy it?	Yes, certainly	frequency	39	8	6	53
		% included in SPC	62,9%	25,0%	100,0%	53,0%
		% of total	39,0%	8,0%	6,0%	53,0%
	May be	frequency	18	24	0	42
		% included in SPC	29,0%	75,0%	,0%	42,0%
		% of total	18,0%	24,0%	,0%	42,0%
	Never	frequency	5	0	0	5
		% % included in SPC	8,1%	,0%	,0%	5,0%
		% du total	5,0%	,0%	,0%	5,0%
Total		frequency	62	32	6	100
		% % included in SPC	100,0%	100,0%	100,0%	100,0%
		% of total	62,0%	32,0%	6,0%	100,0%

The results are interesting. 53% of the respondents assure that they deal with an Islamic window. 42% may be and only 5% refused.

The chi-square test confirms the existence of a significant relationship between social professional category and the possibility to purchase an Islamic banking product from a conventional bank with a confidence interval of 0% of $K^2 = 0.000 < 0.050$.

Managerial Implications and Discussion

The outcomes of the research showed a lack of knowledge of Islamic banking products. Only, Murabaha is known by 34% of the respondents. The majority of the respondents ignore the Islamic banking products. The marketers of Islamic banks should make more effort in communication and education about Islamic banking. Marimuthu et al. (2010) found that the lack of product information is considered by 47.30% of respondents as a reason for non-attendance of Islamic banks. These results show that Islamic banks have a great interest in strengthening their communication policy with their clients. It must be educational, disseminating useful information on the benefits and the operation of the products marketed (Kaabechi 2015).

Even the perception of differences between Islamic and conventional banking products should be enhanced by the communication. The respondents don't distinguish between Islamic and conventional banking products, it's the responsibility of the marketers to explain, to inform, to lighten this differences. There are stereotypes, misunderstanding, and ambiguity about Islamic banking products.

CONCLUSION

The aim of this paper is to develop a better understanding of the effect of social professional category on the acceptance of an Islamic banking product offered by a conventional bank in Tunisia.

The main results showed that there is a large acceptance to this new Islamic product offered by a conventional Bank. Therefore marketers should make more effort in communication: to inform, to explain, to educate and to lighten the differences between Islamic and conventional banking products and services.

Recognizing customers based on their socio demographic characteristics and preferences will be important for Islamic banks or Islamic windows to adopt an appropriate strategy and to provide suitable services to them. Therefore, this study was an attempt to review the studies related to patronizing Islamic banks and the socio-studies related to them.

This study contributes to lighten the research on Islamic banking products acceptance in Tunisia: the case of Islamic window. Despite the evolving literature on Islamic finance, much work remains to be done on consumer behavior using more elaborated models, software data analysis and larger samples. Second, this work on the impact of social professional category on consumers' acceptance towards Islamic banking product offered by a conventional bank. Other socio-demographic characteristics like: income, gender, age should be interesting to study their impact.

REFERENCES

- Ahmad, A., K.U. Rehman, and N. Safwan,(2011). Comparative study of Islamic and conventional banking in Pakistan based on customer satisfaction .*African Journal of Business Management*, 5(5): p. 1768-1773.
- Ajili, W. & Ben Garra, Z. (2013). What for Future For Islamic Finance In Tunisia?. *Etudes en Economie Islamique*, 7(1) 31-70.
- Amin, H.,(2012) Patronage factors of Malaysian local customers toward Islamic credit cards. *Management Research Review*, 2012. 35(6): p. 512-530.
- Asyraf .W. D and Nurdianawati.I.A (2006). Why do Malaysian Customers patronize Islamic Banks? *International Journal of Bank Marketing*, Vol.25 No.3, pp.142-160.
- Chebab, S. & Zribi, H. (2012). Expected regret and Islamic banking in emerging countries: The case of Tunisia, *Journal of Business Studies Quarterly*, 3 (4)119-131.
- Erol, C., El-Bdour, R. (1989). Attitude, behaviour and patronage factors of bank customers towards Islamic banks. *International Journal of Bank Marketing*, Vol. 7 No.6, pp.31-7.
- Erol, C., Kaynak, E., El-Bdour, R. (1990). Conventional and Islamic bank patronage behaviour of Jordanian customers. *International Journal of Bank Marketing*, Vol. 8 No.5, pp.25-35.
- Kaabachi, S (2015). Le comportement du consommateur envers les banques islamiques : une méta-analyse des perceptions, des attitudes et des critères de choix des individus. *Les cahiers de la finance islamique*, université de Strasbourg, ANR, France, N°8, pp 7-40.
- Kaabachi, S., & Obeid, H. (2014). The Islamic Bank in Tunisia: Brakes, Motivations and Expectations of the banking clientele. *Banque et Strategie*, 323 41-50.
- Marimuthu, Chan W.J., Lim P.G., Low P.M., and Tan Y.P. (2010).Islamic Banking: Selection Criteria and implications. *Global Journal of Human Social Science*, Vol.10, no 4, pp. 52-62.
- Metawa, S.A., Almosawi, M. (1998).Banking behavior of Islamic bank customers: perspectives and implications. *International Journal of Bank Marketing*, Vol. 16 No.7, pp.299-313.
- Obeid, H & Kaabachi, S.,. (2016). Empirical Investigation Into Customer Adoption Of Islamic Banking Services In Tunisia. *The Journal of Applied Business Research* – July/August 2016 Vol 32, N° 4, 1243-1256.

Othman, A. and Owen, L. (2001). Adopting and measuring customers service quality (SQ) in Islamic banks: a case study in Kuwait finance house. *International Journal of Islamic Financial Services*, Vol.3 No.1, pp.1-26.

Gait, A (2009).The impact of demographic variables on Libyan retail consumer's attitudes towards Islamic methods of finance. *Islamic Economic Studies* Vol. 17 No. 1, June, : 1-18.

Gait, A and Worthington A (2008). An empirical survey of individual consumer, business firm and financial institution attitudes towards Islamic methods of finance. *International Journal of Social Economics* **35**(11): 783–808.

Khan, M.S.N., M.K. Hassan, and A.I. Shahid (2008). Banking behavior of Islamic bank customers in Bangladesh. *Journal of Islamic Economics, Banking and Finance*, .3(2): p. 159-194.

Khan, M.S.N., M.K. Hassan, and A.I. Shahid,(2007). Banking behavior of Islamic bank customers in Bangladesh. *Journal of Islamic Economics, Banking and Finance*,. 3(2): p. 159-194.

Ltifi, M., Gharbi, J & Aliouat ,B (2015). La sélection des banques islamiques en Tunisie: rôle modérateur du genre et de l'âge . Proceedings of the 13th ATM Colloquium 3-4 April, Sfax Tunisia 1-29.

Metawa, S.A. and M. Almosawi (1998). Banking behavior of Islamic bank customers: perspectives and implications. *International Journal of Bank Marketing*, . 16(7): p. 299-313.

Metwally, M (2002).The impact of demographic factors on consumers' selection of a particular bank within a dual banking system: a case study. *Journal of International Marketing and Marketing Research* **27**(1): 35-44.

Othman, A. and Owen, L. (2002). The multi dimensionality of Carter Model to measure customer service quality (SQ) in Islamic banking industry: a study in Kuwait finance house. *International Journal of Islamic Financial Services*, Vol.3 No.4, pp.1-12.

Slimene, N., Makni, S. & Ben Rejeb, J. (2014). Ethical Performance of Islamic Banks: the Case of the Tunisian Banking Zaytuna. *Journal of Islamic Banking and Finance*, 2(1), 107-122.

Visser, H (2013); the Islamic Finance: principles and practice; second Edition, Edward Elar Publishing.UK.pg 256.

Zainuddin, Y, Jahyd N and Ramayah T (2004), “Perception of Islamic banking: does it differ among users and non users”, *Journal of Management & Business* **6**(3): 221-232.

RELATIONSHIP BUILDING DIMENSIONS TO STRENGTHEN CUSTOMER LOYALTY – AN ISLAMIC BANKING PERSPECTIVE

Shandi Els, Mornay Roberts-Lombard and Elsabe Conradie
University of Johannesburg, South Africa

ABSTRACT

No previous study has been conducted on the relevance of the factors of trust, relationship expectations, two-way communication, conflict handling and commitment in securing the loyalty of Islamic banking customers in the South African banking sector. The population was defined as all Islamic banking customers in the Gauteng Province of South Africa who have been with their bank for one year or longer. A non-probability sampling approach was followed and a self-administered questionnaire was disseminated. Structural Equation Modelling (SEM) was used to analyse the results. The findings conclude that trust and two-way communication impact the commitment of Islamic banking customers towards their bank, whilst commitment has a positive influence on customer loyalty.

Keywords: relationship marketing, customer loyalty, relationship commitment, emerging.

INTRODUCTION

Formal Islamic banking products and services in South Africa are in their early stages, as the process started in 1989 (Saini, Bick & Abdulla 2011, p. 299). In South Africa, there are various degrees of the intensity of the Islamic banking products offered. Two banks offer products according to Shariah law, namely Albaraka Bank and the Oasis Asset Management. There are also three complete Islamic banks in South Africa namely Albaraka Bank, HBZ Bank and the Habib Bank (Mzwandile, 2012). The conventional banks that offer Islamic banking departments are Absa, which is known as Absa Shariah Banking, and FNB, which is known as FNB Islamic Banking (The Banking Association South Africa, 2016). Competition in the South African banking industry is increasing. This requires an increased focus on marketing efforts to build relationships that will enhance customer loyalty amongst all segments of the banking market, inclusive of the Islamic segment (Mishra & Vaithianathan, 2015, p. 122). Islamic banking makes use of unique advantages to build relationships with customers and operate on strict guidelines stemmed from the Qur'an. This permits Islamic banking to create both a constant and socially responsible basis contributing to its successful existence (Mukhtar & Butt, 2012, p. 110). In order to secure a constant and socially responsible basis for successful service delivery to Islamic banking customers, different principles are required to secure customer loyalty. These principles include trust, managing expectations, two-way communication, and the management and resolution of conflict, and securing commitment, are required.

To any organisation, customer loyalty plays a crucial part in their operations as it steers towards larger profits and reduced costs (Sayani, 2015, p. 352). Saini *et al.* (2011, p. 298) emphasise that insufficient information is available and known about the use of Islamic banking in South Africa, as Islamic finance, banking and investment services are still in their initial stages. As a result, there are numerous opportunities in understanding the needs of Islamic customers in South Africa in order to build sufficient relationships with their service offerings (Saini *et al.*, 2011, p. 299). To date, no comprehensive study has been conducted on the relevance of the four factors of trust, relationship expectations, two-way communication and conflict handling to secure the establishment of long-term marketing relationships through the creation of commitment in the South African Islamic banking sector. To address this research gap, it was the aim of the study to focus on the Islamic banking customers of the retail banks in South Africa offering

Islamic banking services. Once these factors have been considered, retail banks in South Africa might be in a better position to secure greater customer loyalty amongst their Islamic banking customers over the long term.

LITERATURE REVIEW

Relationship Building Dimensions to Strengthen Customer Loyalty

Trust and commitment

Trust is perceived as a key variable for the establishment, management and growth of a beneficial functional relationship between a customer and an organisation (Hansen, 2012, p. 280). Hansen (2012) further argues that trust can be broadly defined as “the expectation held by the customer that the service provider is dependable and can be relied on to deliver on its promises” (p. 280). This implies that the ability of an organisation to deliver services in an efficient, fast and professional manner to address the needs of customers will enhance the customer’s level of satisfaction and trust in the service provider. An increased level of trust will in turn result in a greater willingness amongst parties to have a long-term relationship focus (Sayani, 2015, p. 352).

Based upon these findings, the following hypothesis can be formulated for the study:

H1: There is a significant positive relationship between perceived trust and commitment.

Relationship expectations, conflict handling, two-way communication and its relationship to commitment

Both parties to a relationship, the customer and the bank, engage in reoccurring long-term relationships mainly for the expectation of benefits. A bank expects to receive higher profits, growth and competitiveness to competition being managed as a result of loyalty building through committed customers. A customer expects to receive a fundamental service offering as a basis and relational added benefits when committed to a service provider such as a bank. Conflict can be defined as a process that involves two or more social bodies expressing disagreement amongst each other (Ergeneli, Camgoz & Karapinar, 2010, p. 15). These disagreements can result from differences in thinking, ideals or standpoints between people (Mazaheri, Basil, Yanamandram & Daroczi, 2011, p. 236-237; Mrayyan *et al.*, 2008, p. 122). Mrayyan *et al.* (2008) are of the opinion that conflict can be classified as being “intrapersonal, interpersonal and intergroup” (p. 122). Balaji, Roy and Wei (2016, p. 186) deem two-way communication as the essence of relationship management, as it delivers an indication of the other party’s intents, and therefore it promotes commitment, trust and the need to exchange information in order to uphold long-term relationships. In addition, communication can reduce hesitation and doubt in a customer’s mind, increase their confidence in the product, and reassure the customer to remain loyal with the service provider (Balaji *et al.*, 2016, p. 186). Studies by Bekmeier-Feuerhahn and Eichenlaub, 2010, p. 340) and Metawa and Almossawi (1998, p. 300) identified that continuous interaction between a customer and a bank through professional communication positively contributes to customer satisfaction, thereby leading to increased customer commitment.

Based upon these findings, the following hypotheses can be formulated for the study:

H2: There is a significant positive relationship between perceived relationship expectations and commitment.

H3: There is a significant positive relationship between perceived conflict handling and commitment.

H4: There is a significant positive relationship between two-way communication and commitment.

Relationship commitment and customer loyalty

Having highly motivated employees who are engaged with the customer is key in strengthening customer commitment levels, eventually securing long-term customer loyalty. Banks are using employee engagement programmes whereby they strive to train, motivate and enhance the skills of employees in order to deliver excellent service on an operational level. Employees who engage with customers on a regular basis, are focused on exceeding the needs of customers, which assists in building customer commitment and customer loyalty over the long term (Ferdous, Herington & Merrilees, 2013, pp. 640-641; Devi, 2009, p. 3).

Based upon these findings, the following hypothesis can be formulated for the study:

H5: There is a significant positive relationship between commitment and customer loyalty.

METHODOLOGY

The researchers followed an exploratory and quantitative design to conduct the survey. The population of the study comprised all Islamic banking customers of the South African retail banks offering Islamic banking services in the Gauteng Province of South Africa. The Gauteng Province was selected because of the fact that it represents an urban area and can be regarded as the economic hub of South Africa. The study of the Gauteng Province would therefore assist the researchers in the compilation of customer loyalty guidelines that reflect insight from a major urban sphere of the South African economy. Accordingly, the sample for the survey consisted of all individuals in Gauteng who have had an Islamic banking account at any of the four major banks in South Africa for one year or longer. The non-probability convenience sampling technique was applied, as a complete list of the population was not available. The respondents were requested to rate a series of statements on a self-administered questionnaire using a five-point Likert scale, where 1 indicated “strongly disagree” and 5 indicated “strongly agree”. The questionnaire was adapted from scales that had previously been validated by Du Plessis (2010) and Bresler (2013) in related studies amongst respondents in the insurance and banking industries in South Africa. The first part of the questionnaire gathered the demographic data of the respondents. The remaining part of the questionnaire comprised of a list of scales for the independent variables, as well as the dependent variable, customer loyalty. A total of 189 questionnaires were completed and could be used to analyse the results. After the data had been coded, captured and edited, AMOS version 23 was used to conduct the statistical analysis. Cronbach alphas were determined to assess the reliability of the scales used. Further statistical techniques employed included SEM to determine the model fitness and applied the goodness-of-fit tests. Goodness-of-fit information included, for example, the Chi-square test, the Root Mean Square Error of Approximation (RMSEA), the Chi-square test of model fit (CFI/TLI) and the Standardised Root Mean Square Residual (SRMR).

RESULTS

Structural Model: Hypothesis Testing

The structural model was built after confirming the validity and reliability of the scales (refer to Figure 1). The significance of each path coefficient (this refers to the strength of prediction of the independent variable on dependent variable). The structural model presented good model fit indices: CMIN/Df = 1.877; AGFI = 0.815; CFI = 0.916; TLI = 0.902; RMSEA = 0.068. Therefore, the structural model fits the data satisfactorily.

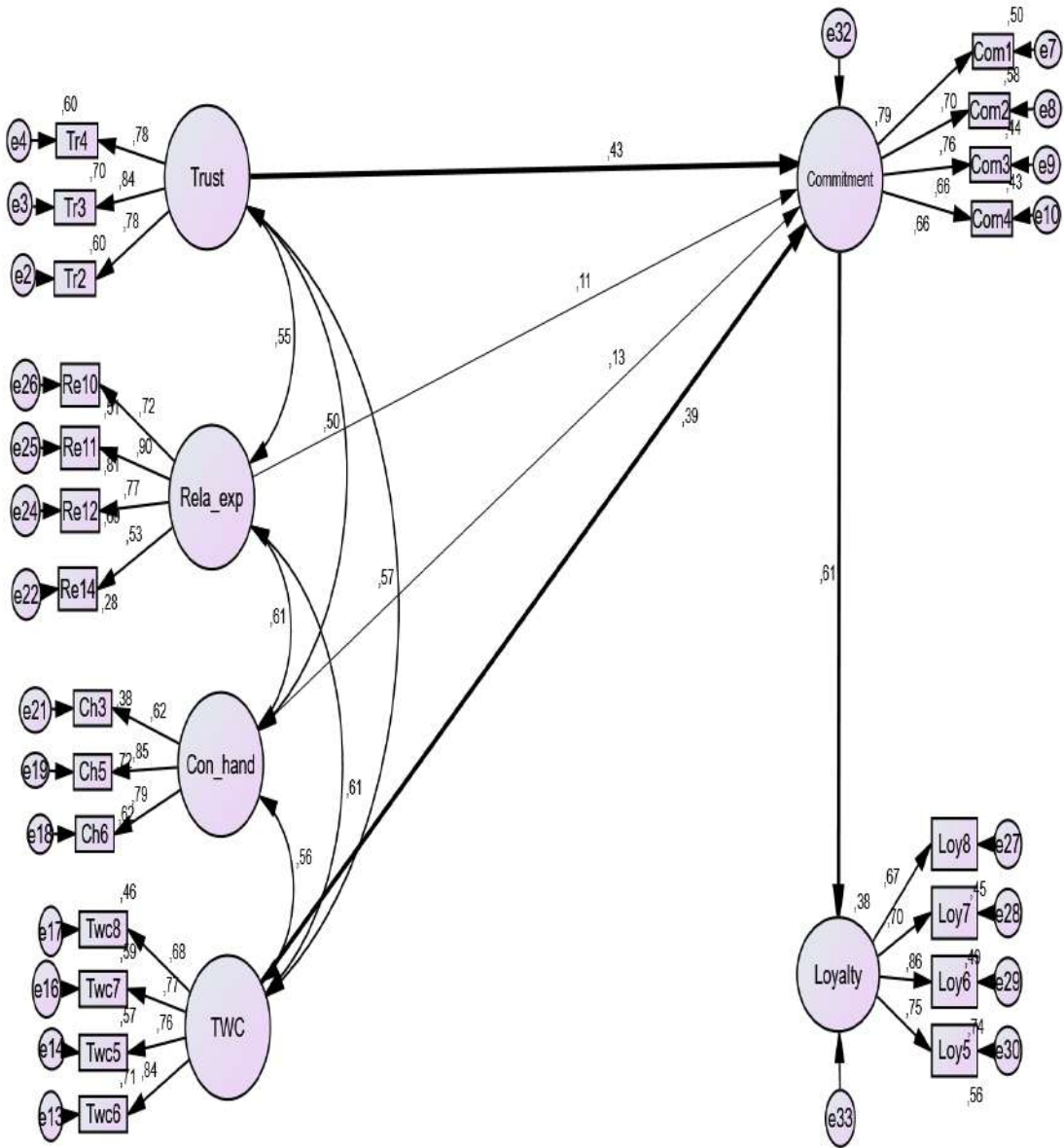

Figure 1: Structural model
 Source: Researchers' own construct

The process of testing hypotheses entails an evaluation of the path coefficients (strength of the regression path), the P-value and the variance explained (R^2 value). The results of the structural model are summarised in Table 1.

Table 1: Results of structural model

Proposed hypothesis relationships			Path coefficients	P-value	Rejected or accepted	Variance explained
Trust	--->	Commitment	0,426	0.001	Accepted	0.790
Rela_exp	--->	Commitment	0,107	0,220	Rejected	
Con_hand	--->	Commitment	0,134	0,110	Rejected	
TWC	--->	Commitment	0,392	0.001	Accepted	
Commitment	--->	Loyalty	0,614	0.001	Accepted	0.377
Correlation relationships			Correlation coefficient	P-value	Significance	
Trust	<-->	TWC	0,572	0.001	Statistically significant	
Trust	<-->	Con_hand	0,499	0.001		
TWC	<-->	Con_hand	0,564	0.001		
TWC	<-->	Rela_exp	0,61	0.001		
Trust	<-->	Rela_exp	0,548	0.001		
Con_hand	<-->	Rela_exp	0,608	0.001		

The modification indices obtained from AMOS outputs suggested that the model should account for correlations between the four determinants of commitment. Table 1 indicates that there is a statistically significant interplay between the antecedents of commitment. Concerning the hypotheses testing, the results established that the constructs relationship expectations and conflict handling do not significantly predict commitment in the study. Only trust ($\beta = 0.426, p < 0.001$) and two-way communication ($\beta = 0.396, p < 0.001$) significantly predict commitment, with trust being the strongest predictor. Remarkably, the structural model indicates that trust, two-way communication, relationship expectations, and conflict handling explained up to **79%** of the commitment of customers in the Islamic banking segment of the four major South African banks. In addition, commitment explains up to **37%** of the customer loyalty of customers in the Islamic Banking segment of the four major banks in South Africa.

Considering the information provided above, the hypotheses H1, H4 and H5 are supported:

- H1: There is a significant positive relationship between perceived trust and commitment.
- H4: There is a significant positive relationship between two-way communication and commitment.
- H5: There is a significant positive relationship between commitment and loyalty.

Hypotheses H2 and H3 are rejected:

- H2: There is no significant relationship between relationship expectation and commitment.
- H3: There is no significant relationship between conflict handling and commitment.

Mediation Analysis

To push the analysis forward, the researchers evaluated the mediating role of commitment in the relationships between trust, two-way communication and loyalty respectively. However, the mediating role of commitment in the relationships with conflict handling and relationship expectations was not evaluated, because they have no significant relationship with commitment. The mediation analysis was carried out using the Hayes (2013) macro for mediation analysis in SPSS. The results of the mediation analysis shows a positive and significant total effect of two-way communication on loyalty ($c = 0.338$; $t = 4.815$). When adding commitment as a mediator, the effect of two-way communication on loyalty decreases, but maintains a significant direct effect on loyalty commitment ($c' = 0.248$; $t = 3.088$; $p > 0.05$). This suggests a partial mediation of commitment in the relationship between two-way communication and loyalty (BootLLCI = 0.006; BootULCI = 0.203; $p < 0.05$). This means that two-way communication should be combined with commitment in order to produce a greater impact on loyalty. The results further indicates a positive and significant total effect of trust on loyalty ($c = 0.220$; $t = 3.234$; $p < 0.05$). When adding commitment as mediator, trust decreases its influence on loyalty ($c' = 0.139$; $t = 1.823$; $p > 0.05$), and its effects become insignificant. This is suggesting a total mediation of commitment on the relationship between trust and loyalty (BootLLCI = 0.005; BootULCI = 0.176; $p < 0.05$). This also suggests that in order to maximise the effect of trust on loyalty, commitment should be involved as a mediator.

MANAGERIAL IMPLICATIONS

Guideline 1: Winning the trust of Islamic banking customers

Once a bank has established a relationship with a new customer or is in the phase of prospecting for new customers, Islamic banks need to highlight their employees' set of interactive skills and emphasise the additional service offerings that are available at the Islamic bank. This allows an Islamic bank to distinguish itself as unique as compared to a conventional bank. This guideline can assist the bank in building up a relationship of trust between itself and its customer (Coulter & Coulter, 2002, p. 45).

Guideline 2: Improving two-way communications with Islamic banking customers

Islamic banks in South Africa, or those with Islamic windows, should consider the development of segment-specific communication channels, aimed at enhancing communication with the Islamic banking customer segment by considering technological, religious and personal communication requirements of this segment. This approach will allow the customers of the bank to interact with the bank with greater ease, supporting a more customer-centric approach to communication by the bank. In conclusion, if the Islamic banking customers' needs are met in terms of communication, it will enhance the collaboration between the customer and the bank.

Guideline 3: Managing the relationship expectations of Islamic banking customers

In today's fast-paced world, customers require convenience, especially if they have to conduct banking transactions. For that reason ATMs, self-service kiosks and branches should be available in all metropolitan areas as well as in shopping malls visited by the bank's customers (Kumar, Malathy & Ganesh, 2011, p. 498). The bank should make use of their internal customer demographic data to establish which areas are most populated by the bank's customers to assess where more ATMs, self-service kiosks and branches are required. If there is ample access to the bank, customers' expectations will be met resulting in improved relationships. As technology advances, customers expect their banks to stay abreast of technology. Therefore, a bank should invest in having an easy to use mobile banking application as well as a user-friendly Internet banking site. The bank should ensure that both the mobile application and internet site is maintained to allow customers to access the sites and complete their banking transactions without any delays or complications.

Guideline 4: Improving on the conflict handling of Islamic banking customers

It is not uncommon for a bank to encounter a problem that can affect the Islamic banking customer. In order to maintain the relationship with a customer, a bank is required to firstly apologise to all customers who were affected by the problem. The means of apologising will depend on the severity and the number of impacted customers. If a problem arose with only one customer, the apology can be done in person by the branch manager or a personalised email can be sent by a manager to the customer, stating their sincere apology. However, if the problem involves more than one person, several options are available to apologise; send personalised emails, approach a news agency to write a letter of apology and explaining how the problem will be rectified, or apologise by means of a social media platform such as Facebook or Twitter.

Guideline 5: Obtaining Islamic banking customer commitment

Various means can be used to show the commitment towards the customers, such as delivering on promised services, communicating regular updates through the customers' preferred communication channels, and offering exceptional customer service by continuously training employees to deliver on Islamic banking customer-specific needs.

LIMITATIONS AND FUTURE RESEARCH

The study was conducted in the Gauteng Province of South Africa, as it represents the economic hub of the South African Islamic banking customer base. However, this limits the generalisation of the results of the study to the entire South African Islamic banking population. It is therefore suggested that a future study be conducted amongst all Islamic banking customers in South Africa in all the different provinces of the country. In terms of future research, the application of both qualitative and quantitative research techniques can be considered to obtain greater in-depth insight behind the need of Islamic banking customers to remain loyal towards their bank.

CONCLUSIONS

It is vital that Islamic banks maintain and uphold a level of commitment towards the bank customers in order to drive the growth of this niche banking industry even further, as well as to secure customer loyalty. To achieve such a task, the Islamic banks would need to concentrate on the elements that could assist them to drive growth and loyalty amongst their customers. The study investigated the relationship amongst key variables and customer loyalty in the Islamic banking industry. The empirical findings revealed several factors on which the Islamic banks need to concentrate in order to build customer loyalty, comprising mainly trust, commitment and two-way communication.

REFERENCES

Balaji, M.S., Roy, S.R. & Wei, K.K. (2016). Does Relationship Communication Matter in B2C Service Relationships? *Journal of Services Marketing*, 30(2), 186-200.

Banking Association South Africa. (2016). Viewed 2 August 2016 at <http://www.banking.org.za>.

Bekmeier-Feuerhahn, S. & Eichenlaub, A. (2010). What Makes for Trusting Relationships in Online Communication? *Journal of Communication Management*, 14(4), 337-355.

Bresler, M. (2013). Black Generation Y Expectations of their Bank's Customer Relationship Management. Master's Dissertation, University of Johannesburg.

- Coote, L.V., Forrest, E.J. & Tam, T. (2003). An Investigation into Commitment in Non-Western Industrial Marketing Relationships. *Industrial Marketing Management*, 32(7), 595-604.
- Coulter, K.S. & Coulter, R.A. (2002). Determinants of Trust in a Service Provider: The Moderating Role of Length of Relationship. *Journal of Services Marketing*, 16(1), 35-50.
- Devi, V.R. (2009). Employee Engagement is a Two-way Street. *Human Resource Management International Digest*, 17(2), 3-4.
- Du Plessis, L. (2010). Customer Relationship Management and its Influence on Customer Loyalty at Liberty Life in South Africa. Master's Dissertation, University of Johannesburg.
- Ergeneli, A., Camgoz, S.M. & Karapinar, P.B. (2010). The Relationship Between Self-efficacy and Conflict-handling Styles in terms of Relative Authority Positions of the Two Parties. *Social Behavior and Personality – an International Journal*, 38(1), 13-28.
- Ferdous, A.S., Herington, C. & Merrilees, B. (2013). Developing an Integrative Model of Internal and External Marketing. *Journal of Strategic Marketing*, 21(7), 637-649.
- Hansen, T. (2012). Understanding Trust in Financial Services: The Influence of Financial Healthiness, Knowledge, and Satisfaction. *Journal of Service Research*, 15(3), 280-295.
- Hayes, A.F. (2013). *Introduction to Mediation, Moderation, and Conditional Process Analysis: A Regression-based Approach*. New York: Guilford Press.
- Kumar, L., Malathy, D. & Ganesh, L.S. (2011). The Diffusion of ATM Technology in Indian Banking. *Journal of Economic Studies*, 38(4), 483-500.
- Mazaheri, E., Basil, D., Yanamandram, V. & Daroczi, Z. (2011). The Impact of Pre-existing Attitude and Conflict Management Style on Customer Satisfaction with Service Recovery. *Journal of Retailing and Consumer Services*, 18, 235-245.
- Metawa, S.A. & Almosawi, M. (1998). Banking Behavior of Islamic Bank Customers: Perspectives and Implications. *International Journal of Bank Marketing*, 16(7), 299-331.
- Mishra, V. & Vaithianathan, S. (2015). Customer Personality and Relationship Satisfaction. *International Journal of Bank Marketing*, 33(2), 122-142.
- Mrayyan, M.T., Modallal, R., Awamreh, K., Atoum, M., Abdullah, M. & Suliman, S. (2008). Readiness of Organizations for Change, Motivation and Conflict-handling Intentions. *Nurse Education in Practice*, 8, 120-128.
- Mukhtar, M. & Butt, M. (2012). Intention to Choose Halal Products: The Role of Religiosity. *Journal of Islamic Marketing*, 3(2), 108-120.
- Mzwandile, J. (2012). *Islamic finance unpacked*. Viewed 23 July 2016 at <http://www.fin24.com/Money/Investments/Islamic-finance-unpacked>.
- Purnasaria, H. & Yuliandoa, H. (2015). How Relationship Quality on Customer Commitment Influences Positive e-WOM. *Agriculture and Agricultural Science Procedia*, 3, 149-153.
- Saini, Y., Bick, G. & Abdulla, L. (2011). Consumer Awareness and Usage of Islamic Banking Products in South Africa. *South African Journal of Economic and Management Sciences*, 14(3), 298-313.
- Sayani, H. (2015). Customer Satisfaction and Loyalty in the United Arab Emirates Banking Industry. *International Journal of Bank Marketing*, 33(3), 351-375.

PURCHASING-CONSUMING CYCLE MODEL OF CONSUMERS AND RETAILERS' INVENTORY STRATEGY

Hisao Fujimoto, Osaka University of Economics, Japan

Yuko Hayashi, Meio University, Japan

Yasuhiko Kubo, Sagami Women's University, Japan

ABSTRACT

This paper explores the importance of consumers' inventory for distribution channels. For this purpose, this study approaches consumers' shopping behavior from their purchasing-consumption cycle, and the changing relationships to distribution channel members in Japan. In addition, this study based on a purchasing behavior model and the data of local consumers' buying behavior of Japanese consumers, focusing especially elderly and handicapped people, suggests that Japanese consumers can offer opportunities to local small retailers. Moreover, this model can bring a new insight for retailers' demand forecast in improving retailers' inventory policy

INTRODUCTION

After 1980, Japanese retail sector has been facing the continuous decline of the number of small retailers. Many small retailers are alert to the concerns and needs of residents. In other words, they have to know local residents and what are their satiation in purchasing goods. Knowing something about residents' attitude and behavior with regard to their interests and opinions of community will enhance retailers' ability to target viable segments efficiently.

The purpose of this paper is to explore the importance of inventory holding of consumers approaching from their shopping behavior and purchasing-consumption cycles. In the next two sections, the structure of Japanese retail sector is briefly surveyed and the distribution functions are discussed. In the following section, the characteristics of Japanese consumers' shopping behavior. After that, the consumer shopping behavior and purchasing-consumption cycles are classified into several types based on the reconsideration of retail services. The classification will be taken by identifying two dimensions: space and time. Based on this classification, the pattern of a consumer's shopping behavior with the aspect of age and mobility is described. Especially, the study will focus on discussing elderly consumers' characteristics with referring to the classification model. It is also discussed the relationship between the characteristics of the local retailers, and the characteristics of consumers' shopping behavior on the field research data in several local governments. In the concluding section, the findings and for future research to reconsider the consumer shopping behavior and their inventory holding with the retail market structure are discussed.

BRIEF OVERVIEW OF RETAIL STRUCTURE AND CONSUMER MARKET IN JAPAN

The number of retailers in Japan had been in the upward until 1982. Since then the number had continuously been falling. Although the data of the research in 2014 is the recent official reliable data, it can be supposed that this downward trend has been continuing. It had reduced down to 775,196 in 2014 from 1,721,465 in 1982. About 55% of retail stores had been out of business during this period.

While the number of incorporated retail stores had been slowly decreasing after the peak in 1999, the trend of small retailers had moved almost in accordance with the movements of total number of retailers (see Table 1). In spite of this tendency, it suggests that the retail structure in Japan still has been dominantly consisted of small retailers. This fact has been characterizing Japanese retail market structure as the excessiveness and smallness for long time.

The growth of incorporated retail stores in Japan did not mean the increasing pressures of retail competition until 1982. However, that year was a turning point. Small retail stores have been decreasing since then. After 1999 with the decreasing phase of incorporated retailers, the retail competition can be supposed to put on pressures to all retailers. It is proven by the fact of the merger and acquisition of large retailers and the continuing decreasing of small retailers. In addition to the economic depression, the changing of Japanese consumers' life style and their buying behavior has influenced on the retail structure considerably. Among them, the growth of convenience stores and Web retailers have a strong competitive pressure to local small retailers. Many marketing researchers have produced various concepts and theories on this matter. In next section, we will discuss these concepts

Table 1: The Number of Retailers in Japan

Years	Total Number of Retail Stores	Incorporated Establishments	Small Stores (with 1-4 employees)
1962	1,127,975	139,533	1,147,159
1972	1,495,510	265,686	1,276,647
1982	1,721,465	435,822	1,448,747
1985	1,628,644	449,309	1,348,201
1988	1,619,752	503,728	1,296,444
1991	1,591,223	564,642	1,264,135
1994	1,499,948	581,207	1,135,716
1997	1,419,696	586,627	1,059,305
1999	1,406,884	607,401	1,002,179
2002	1,300,057	583,899	901,009
2004	1,238,049	578,426	852,876
2007	1,137,859	565,969	775,529
2014	775,196	448,842	485,269

Source: Japan Census of Commerce

TYPES OF RETAIL SERVICES

Bucklin (1963) and Tamura (1982) defined that retailers provide “retail services” for consumers. According to them, these services can be classified into the following four types:

- (1) *Reduction of buying lots*
- (2) *Shortening of trading and delivering time.*
- (3) *Assortment of goods*
- (4) *Providing of accessibility.*

It is important that consumers can also provide these services. In other words, consumers can decide to what extent they receive these services from retailer. If consumers receive considerable part of retail services, they can get goods easily. In this case, they have to pay much, because these service cost has to be added to the price of goods. If not so, they have to bear every effort and can get goods in much cheaper. Consumers have choices to what extent they buy or undertake these retail services. Their decision on retail services will be connected with their store choices as a result.

To consider the small retailers and their market structures, we examine how this matter relates to the “product classification theory”. Copeland (1923) provided the idea that consumer buying behaviors held many of the keys for understanding how retailers should market their products and locate their stores. His approach has been a base for the improvement of the model, and several researchers aroused controversies on this subject. Especially, their arguments concentrated in the criterion to classify the types of products. As a result, they agreed that the cost of search and buying trip is the key factor. Holton (1962) derived the difference between convenience and shopping goods from a continuum defined by the consumer’s perceptions of the costs and benefits from a comparison of the price and quality of goods. Convenience goods, for which the net benefit from cost was negative, positioned at the one pole. Shopping goods, for which there was a net payoff from cost, positioned at the other. Paradoxically, his idea suggested that when consumers perceive these costs equally for every shopping, the classification has no meaning. For example, the development of the suburban life and motorization makes consumers perceive these costs equally (Berry and Parr 1988). People living in the suburbs usually drive cars for every shopping, and their cost perceptions that define the difference between convenience and shopping goods may become ambiguous.

Actually these changes of the consumers’ lifestyle affect the structure of retail districts. Comparing with above-mentioned “retail service types”, however, the motorization can only compensate for the “providing of accessibility”. Whereas the accessibility is a very important aspect for analyzing consumer buying behaviors, it is a just one of them. A many-sided theoretical approach will be needed to examine consumers purchasing behaviors.

DISTRIBUTION FUNCTIONS AND INVENTORY

In modern economy, production and consumption are structurally divided. It means that production and consumption have to be bridged. However, this bridge between production and consumption is not so simple. In distribution channel theory, this bridge is performed by the adjustment process, which bridges gaps between production and consumption. They are called distribution functions. What gaps are exist between production and consumption? Four gaps are assumed in distribution channel theory. (Tamura 2001) They are: 1) gap of ownership, 2) gap of place, 3) gap of time, and 4) gap of information. Among of these gaps and functions, gaps of place and time are assumed to be related to inventory, because these are called physical distribution functions.

Consumer goods move between each stages of distribution channel from manufacturers to consumers. In other words, consumer goods are transacted with the moving phase as “flow” and the staying phase as “stock”. When consumers purchase goods from retailers in the last stage between retailers and consumers, goods will be inventories of consumers till they will consume these goods. When the inventories of consumers are considered from this point of view, we can find several issues of consumers’ inventories. It can be several aspects of consumers’ purchasing and consuming behaviors. In the next section, we will propose an approach to explore this issue.

CONCEPTUAL MODEL OF CONSUMER PURCHASING AND CONSUMING CYCLE

Consumers usually make their purchasing plans before the shopping trips. Considering whether their purchasing actions are done as designed or not is an important criterion, because the purchasing plan prescribes the consumption interval of goods. The consumption interval consists of three time stages as follows:

- (1) Time of decision to what goods or brands should buy.
- (2) Time of action to get goods.
- (3) Time of using and consuming the goods.

Especially, the first stage is decisive on this issue, and two factors have effect on this stage. The first factor is the “sense of stock in house”. If a consumer lays stress on the extent of the stock of goods in house, the buying

plan on these goods is designed as a long-range and firm schedule. In this case, his buying action will become very speculative, and he may order a large amount of these goods. If not so, the buying plan can be easily changed.

The second factor is the “synchronization of the consumption interval”. In generally, a consumer buys many kinds of goods at one shopping, because the buying or trip cost per one goods can be decreased. The more a consumer purchases many goods at one time, the more he can be benefited over the shopping cost. In short, a consumer may synchronize his consumption intervals of many kinds of goods to make an efficient buying plan. In this case, his action is also speculative, and the frequency of shopping trips can be reduced. Before stage (2), inventories are stocked in retailers, and inventories are hold by consumers after stage (2) till their consumption.

We can classify the consumer purchasing-consuming cycle model. This is accomplished by identifying two dimensions: “the axis of space” and “the axis of time”. The space axis is a criterion of judgment on consumer’s accessibility to retail store. At one side of this dimension is the “decentralization”, which means the store’s location to be decentralized in a given market area. When a consumer chooses a store located close to him, it reflects that he lays stress on the accessibility. At the opposite side is the “centralization”, which means the centralized retail location, as a commercial center or shopping center, at one district in a given market area.

The type of consumption interval is determined by time dimension. When the interval is short, it is categorized as the “frequent buying”. If the interval is relatively long, it is assumed the “non-frequent buying”. The consumer purchasing behavior can be divided into following four types.

- (1) *Frequent centralization purchasing*
- (2) *Frequent decentralization purchasing*
- (3) *Non-frequent centralization purchasing*
- (4) *Non-frequent decentralization purchasing*

It is important that this classification also has the relationship with retail services provided.

To explain the reasons that the number of small retailers could occupy the majority in Japanese retail structure for long time, some researchers have introduced several consumer behavior approaches. For example, Maruyama(1992) and Naryuu(1994) insist that Japanese consumers have a strong taste for fresh products, such as raw fish and fresh vegetables, instead of processed foods like canned or frozen foods. All the products are perishable, preserved only for a short period of time even in a refrigerator. They also argue that the average house space in Japan is generally narrow. Therefore, the cost of inventory stock of goods in house is rather high. Because of these points, they conclude that Japanese consumers go shopping frequently in small lots at each purchase. It leads to the retail structure with a large number of small retailers densely located near to residential area.

One more important fact is that many Japanese women get their own jobs. In generally, housewives living in developed countries tend to purchase many goods on one stop shopping. Their rate of occupation is rather high and their opportunity cost for shopping also has become high, because many Japanese women still bear the work of shopping even if they have a job. This can explain that these shoppers are the less frequent shoppers, and their shopping trips should be well planned in advance of visiting stores. They try to simplify their trips and to reduce the number of stores they plan to visit. As a result, they prefer the “one-stop shopping” at shopping centers and /or large stores. The consumers’ shopping pattern, which can be grouped as the “frequent centralization purchasing” and the “non-frequent centralization purchasing”, can be supposed to have the effect to reduce the survival rate of local small retailers.

DISCUSSION AND MANAGERIAL IMPLICATION

Retailers should focus their attention on the particular consumer segments to develop effective strategies. In this paper, the authors tried to classify the consumer purchasing behavior as a base for developing strategies. As the

result, consumers who carry out the “frequent decentralization purchasing” are congenial to small residential retailers. These consumers tend to complete their daily shopping within their local communities.

The study suggests that elderly and handicapped consumers can be a promising segment to become potential customers for local small retailers. Their behavior can be classified into the “frequent decentralization purchasing”. They may be not so conscious of price, but conscious of high level services. Small retailers can provide them with many kinds of services as important social supports. Several small retailers already have begun to recognize the importance of elderly and handicapped consumers and grapple with new retail services such as the convenient ordering and delivery systems. When retailers can serve to consumers’ access and frequent purchasing, it can reduce the burden of consumers’ stock keeping.

The economic activities involved in the consumer-retailer exchange are embedded in the community’s social structure. Rural small retailers are encouraged to focus on a specific segment that has a majority in the community, and to increase their own involvement in community activities. Elderly and handicapped consumers who have been considered as the economic and social minority will become the important segment of market and local small retailers. This approach from consumers’ purchasing-consuming cycle can bring a new sight for local small retailers’ inventory policy from improving demand forecast and the retailers’ role as the social capital.

REFERENCES

- Bergmann, J. (1998). Small Markets Are Attracting More Retailers. *Discount Merchandiser* 38 (May): 42-46.
- Berry, B. J. and Parr, J. B. (1988) *Market Centers and Retail Location*. Prentice Hall, Englewood Cliffs, NJ.
- Betancrot, R. R., and Gautschi D. (1990). Demand Complementarities, Household Production and Retail Assortments. *Marketing Science* 9 (Spring1990): 146-161.
- Betancrot, R. R., and Gautschi D. (1992). The Demand for Retail Products and the Household Production. *Journal of Economic Behavior and Organization* 17 (March): 257-275.
- Bucklin, L. P. (1963). Retail Strategy and the Classification Consumer Goods. *Journal of Marketing* 27 (January): 50-58.
- Copeland, M. T. (1923). Relation of Consumers' Goods of Buying Habit. *Harvard Business Review* 1 (April): 282-289.
- Fujimoto, H., Sasakawa Y., and Kubo Y. (1999). The Structure and Problem of Small Retailers in Japan. *Business Economy* 35 (November): 83-102.
- Holton, R. H. (1958). The Distinctions between Convenience Goods, Shopping Goods, and Specialty Goods. *Journal of Marketing* 22 (July): 53-56.
- Holton, R. H. (1962). Competition and Monopoly in Distribution. in *Competition Cartels and Their Regulation* in J. P. Miller, ed. North-Hollander Publishing, Amsterdam, pp.263-307.
- Kean, R. (1998). Effects of Community Characteristics, Business Environment, and Competitive Strategies on Rural Retail Business Performance. *Journal of Small Business Management* 36 (April): 45-57.
- Kim, B. and Park K. (1997). Studying Patterns of Consumer's Grocery Shopping Trip. *Journal of Retailing* 73 (winter): 501-517.
- Maruyama, M. (1992). *Competitive Structure in Japanese Market (Nihon Shijou No Kyouso Kousou)*, Soubunsha, Tokyo.
- Miller, N. J. and Kim S. (1999). The Importance of Older Consumers to Small Business Survival: Evidence from Rural Iowa," *Journal of Small Business Management* 37 (October): 1-15.
- Miller, N. M. (1986). Rural Retailing: The Last Frontier. *Chain Store Age Executive with Shopping Center Age* 62 (March): 18-20.
- Naryuu, T. (1994). *Economic Theory of Marketing and Distribution (Ryuutsuu no Keizai Riron)*. Nagoya Daigaku Shuppan Kai, Nagoya.
- Tamura, M. (1982). *Distribution Industry (Ryutuu Sangyou)*. Nihon Keizai Shinbunsha, Tokyo.
- Tamura, M. (2001). *Principles of Distribution Channels (Ryutuu Genri)*. Chikura, Tokyo.

THE PRIME NUMBERS IN THE KITCHEN

María J. García G., Gilberto J. Hernández G. & José G. Hernández R.
Minimax Consultores C. A., Venezuela

ABSTRACT

This work relates two fields of knowledge and daily work: the prime numbers and the Food pyramid. The human being has always been fascinated by the prime numbers. However, its applications in the daily work are not very noticeable. Only in the era of the Internet, appears a general application of prime numbers, encrypting data. The encryption of information, allows establish exchanges of information protected before third. This is extremely important in bank transfers. However this use of prime numbers is not perceived by the common population and the explanation of its use is not simple. This situation has motivated the search for applications of the prime numbers, which can be used by the ordinary citizen in his daily tasks. Hence the objective of this work: To show how there can be done use of the prime numbers to choose the frequency with which, in a home, a set of certain food is prepared.

Keywords: Food pyramid (FP), Prime numbers, Daily work, Diet problem (DP), Scarce resources, Data Encryption.

INTRODUCTION

The fascination for the prime numbers has accompanied to the human being from very remote epochs (Gueye, 2013; LaTorre & Sierra, 2014; Loebenberger, 2012). By the great dedication to the primes, especially for lovers of mathematics, these can be found in the analysis of many problems. From there they are present, when: the proper prime numbers are studied (Chen, Lin & Gun, 2012; Oehlschlägel, 2014), or study hypothesis related to them, as it is the Riemann hypothesis (Andrade, 2013; França & LeClair, 2015; Menezes & Svaiter, 2013), or in some cases, analyzing them in front of other concepts (Mazur, 2012) either to recognize whether a number is or not prime or to find new prime numbers (Chakrabarty, 2012; Kabwe, 2015) or to establish conjectures that allow to obtain different prime numbers (LaTorre & Sierra, 2014; Menezes, Svaiter & Svaiter, 2013), among these conjectures stand out of Fermat (Kabwe, 2015) and the of Mersenne (Padmaja, Bhagavan & Srinivas, 2016), that, although they have contributed to the advance of the knowledge on the prime numbers, have been found cases where they fail.

Primes are also used to seek approximations or to solve problems in other diverse fields of knowledge, as the Apollonian Circle Packings (Graham. et al., 2003; Pollicott, 2015), or in Fuzzy set (Naraghi & Naraghi, 2012). On the other hand it has studied the Bent functions (Li et al., 2013; Mesnager & Flori, 2012; Tang et al., 2016; Tang & Qi, 2013; Xu, Cao & Xu, 2015; Yu, Liu & Zheng, 2015). These functions are relevant because they are used in one of the largest applications of prime numbers, data encryption (Chen, Lin & Gun, 2012; Padmaja, Bhagavan & Srinivas, 2016). Data encryption is a very important element in modern life, when data must be exchanged, either between mobile phones or even when making large bank transfers. The fact that the data can be encrypted, guarantees its security and that will not be captured by malicious third parties.

If it leaves aside the data encryption and the use of decreasing prime (Pd) (García, Hernández & Hernández, 2015), it is not easy to find applications of prime numbers that reach to the average citizen.

With the intention of covering this gap, it has been thought that one of the problems, where the prime numbers could be used, is to plan the dishes to prepare each day in a home.

When talking about food there are two aspects that arise one is the Food pyramid (FP) and the other is a quantitative approach, the Diet problem (DP). On the one hand, FP, must meet the nutritional requirements that a human needs. On the other hand it should be done at minimum cost following the DP. In this moment there is an aspect that is usually left out and is the frequent repetition of the same food set. It is to minimize this repetition, which has been thought to use prime numbers.

Taking into account all these aspects arise the objective of this work: To show how there can be done use of the prime numbers to choose the frequency with which, in a home, a set of certain food is prepared.

From this general objective arise the following specific objectives:

- It presents the great interest of human beings by the prime numbers.
- Explain the importance of the Food pyramid and the Diet problem.
- To illustrate how, by making use of prime numbers, it is possible to minimize the repetition of a set of foods, which are consumed in a home.

To achieve those objectives, it will be used the Integrated-Adaptable Methodology for the development of Decision Support System (IAMDSS, in Spanish, Metodología Integradora-Adaptable para desarrollar Sistemas de Apoyo a las Decisiones [MIASAD]) (García, Hernández & Hernández, 2014; 2015), which, among its characteristics stands out not to raise hypotheses, but to follow a series of steps. And for its flexibility and adaptability to different types of research (Barreto et al., 2016; García, Hernández & Hernández, 2014; 2015; Hernández, García & Hernández, 2016; Jeney et al., 2015), it can use only the steps that are considered important, from there, similar to what was done in other works (Barreto et al., 2016; García, Hernández & Hernández, 2015; Jeney et al., 2015), only the following steps will follow:

- a) Define the problem, which as indicated in the objectives is to show how there can be done use of the prime numbers to choose the frequency with which, in a home, a set of certain food is prepared;
- b) Elaborate a first prototype, where one of its main functions is to have a complete vision of what the research will be and the first thing to do is to recognize the users of the final product, that is to say the principal readership of this article, that will be all that interested the study of the prime numbers, to which is added the interested in applications of the world of mathematics to everyday life, and the scholars of the better food for humans. Also it pursues, with this first prototype, to establish the structure of the article, which, in addition to this introduction, where there appeared already the interest of the human beings in the prime numbers, it will consist of two central chapters, in the first one of them, there will appear some comments about the FP and the DP and in the second, which comes to be the principal chapter of the work, it will illustrate how it can provide a greater variation in the combination of dishes to serve, in the home, making use of the prime numbers;
- c) To obtain data, in this case on the primes, the FP and the DP;
- d) Define alternatives, which are to visualize how it can make use of the prime numbers to minimize the repetition of combinations of the diverse foods that are served in a home;
- e) To evaluate alternatives. In this case measuring the possibility of minimizing the repetition of food combinations, across the prime numbers, that has every alternative;
- f) Select the best alternative, according to the secondary objectives, tacit or explicit that have been contemplated;
- g) Implement the best alternative, illustrate, through a hypothetical case how could operate the combinations obtained, making use of the prime numbers;
- h) Establish controls, mechanisms, to recognize if the solution achieved, is still valid in the course of time.

In any case, it is important to clarify which you can select a set of alternatives, which together will help to solve the problem.

With respect to limitations and scope, no field work will be performed, but it will be illustrated how the prime numbers work in the minimization of the repetitions of the food combination, through a simple and hypothetical example, to guarantee a greater generality of the application of the obtained results.

BRIEF COMMENTS ON THE FOOD PYRAMID AND THE DIET PROBLEM

The Diet problem (DP), dates from the middle of the forties of last century (Garille & Gass, 2001) and it is fundamental in Operations Research (OR), specifically in Linear Programming (LP), where it is a basic problem and that, as it says Dantzig (1990), it served as a test problem in the beginning of the method SIMPLEX. However saying that the DP is basic, does not mean that it is a simple problem. Depending on the number of variables involved the problem may result from a great complexity. However, the results obtained depend only on the variables and restrictions used, from where it can be said that it is a problem with a universal solution.

For its part, the Food pyramid (FP) is a concept that within its generality presents many peculiarities, so can talk about the FP of Germany (Von Ruesten et al., 2010), from Switzerland (Walter, Infanger & Mühlemann, 2007), from USA (Neuhauser, Rothschild & Rodríguez, 2007), and even talk about FP for special groups such as children, pregnant women, athletes, vegetarians (Walter, Infanger & Mühlemann, 2007), or for diabetics, people with cancer, obese or FP adapted to the Mediterranean diet (Leterme, 2002).

In this sense, an FP will be found by each author or institution that promotes it, however, in general terms, as shown in figure 1, it consists of four or five steps or groups. Generally at the base of the pyramid are placed those types of foods that should be consumed more frequently, mostly daily, group I (GI), while in the cusp are those foods that should be consumed very occasionally, last group (Gm). Most of those who make up the pyramid a fifth step, at the base place drinks, in any case non-alcoholic, and essentially water and usually recommend, additionally, sports or physical activities.

With respect to the DP, as already mentioned is a problem of LP in general minimization, since the objective is to try to minimize the cost of the whole food consumed by a person or group of people, to have a balanced diet and that meets the minimum requirements of a series of factors, that to simplify, only could be mentioned calories, vitamins and minerals. To reach these minimum requirements it must consume a certain amount of certain foods, understanding that every food has associate, a unitary cost and the aptitude to provide a certain number of vitamin units, calories, and minerals per unit of food consumed.

From the quantitative point of view it was possible to represent this simplification as:

$$\begin{aligned} \text{Min } Z_0 &= \sum_{i=1,n} C_i * X_i && (1) \\ \text{Subject to} &&& \\ \sum_{i=1,n} V_i * X_i &\geq VI && (2) \\ \sum_{i=1,n} K_i * X_i &\geq KA && (3) \\ \sum_{i=1,n} R_i * X_i &\geq MI && (4) \\ X_i &\geq 0, \text{ for all } i && (7) \end{aligned}$$

Where each of these terms represent: X_i the variables, that is to say the quantity in grams of each one of i type of available food, C_i the unitary cost of the food i , V_i the vitamin content per unit of food i , VI the minimum amount of vitamins to consume, K_i the calorie content per unit of food i , KA the minimum amount of calories that it should consume, R_i the unit of mineral content of the food i and MI the minimum amount of minerals to consume.

In this case, equation (1) represents the costs to be minimized, equations (2), (3) and (4), represent, respectively, the minimum requirements for vitamins, calories and minerals to be met. And the equation (7) indicates that all variables must be positive.

This very simplified representation is slightly complicated if it is to be related to FP, in this case the visualization of the model, while maintaining the previous simplification, could be:

$$\begin{aligned} \text{Min } Z_0 &= \sum_{i=1,n} \sum_{j=1,m} C_{ij} * X_{ij} & (1a) \\ \text{Subject to} & \\ \sum_{i=1,n} \sum_{j=1,m} V_{ij} * X_{ij} &\geq VI & (2a) \\ \sum_{i=1,n} \sum_{j=1,m} K_{ij} * X_{ij} &\geq KA & (3a) \\ \sum_{i=1,n} \sum_{j=1,m} R_{ij} * X_{ij} &\geq MR & (4a) \\ \sum_{i=1,n} X_{ij} &\geq G_j, \text{ con } j = 1, \dots, m-1 & (5) \\ \sum_{i=1,n} X_{ij} &\leq G_j, \text{ con } j = m & (6) \\ X_{ij} &\geq 0, \text{ for all } i, \text{ for all } j & (7a) \end{aligned}$$

The terms common to equations (1), (2), (3), (4) and (7) maintain their previous meaning and the new terms represent similar meanings, so X_{ij} , are the variables that are now understood as the amount of grams of the type of food i , belonging to group j of the FP. The groups of the pyramid are represented by G_j and begin, as seen in Figure 1, from the base $j = 1$, to the top $j = m$. For their part, the C_{ij} represents the unit cost of food i of group j , the V_{ij} represent the unit vitamin content of the food i of the group j , the K_{ij} the unit caloric content of food i of group j and the R_{ij} the unit mineral content of food i of group j .

The same thing happens with equations (1a), (2a), (3a), (4a) and (7a) which will have meanings equivalent to the equations (1), (2), (3), (4) and (7). Meanwhile the equation (5) represents that of every group j it is necessary to consume at least a quantity G_j , except the last group, where the equation (6) indicates, that at most it is possible to consume an amount G_j , in this case G_m .

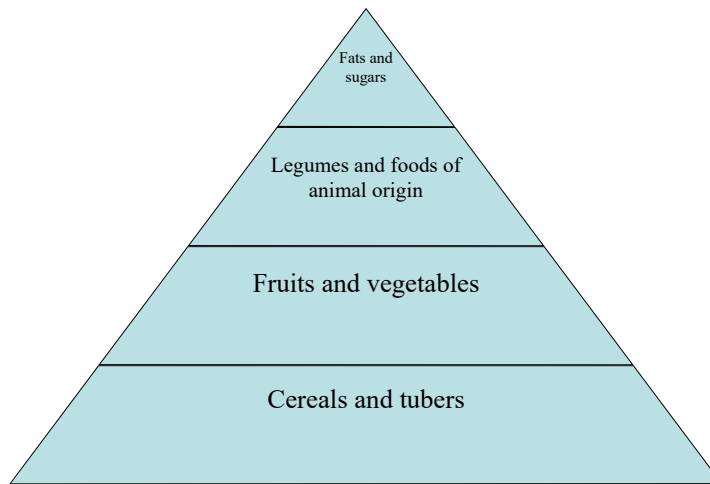

Figure 1: Basic scheme of a Food pyramid.

Although the model here presented, it is extremely simplified, it offers a clear idea on the DP and as this one it is related to the FP. Taking these elements into account, it will go on to illustrate, as by making use of the prime numbers it can make a schedule of the food to be prepared daily in the home, in a way that minimizes repetitions.

USE OF THE PRIME NUMBERS TO MINIMIZE THE REPETITION OF GROUPS OF CONSUMED FOOD

Through examples, hypothetical and simple, we will go on to illustrate how, by making use of prime numbers, it is possible to minimize the repetition of a group of foods, which are consumed in a home.

Without following any particular Food pyramid (FP), it has already been shown that there are types of foods that should be consumed more frequently than others. And it was also shown, through the Diet problem (DP), which although there is a great variety of foods in each group, sometimes the budget does not allow greater variations. Therefore, the responsible person in the household must juggle, to present each day a group of foods, which comply with the FP, which fit the budget and at the same time do not look so repetitive.

Although the frequency of consumption of a certain food, sometimes it is slightly variable, if this one constantly is accompanied of other or others certain foods, the feeling that it is always eating the same is much greater. So one way to ensure that it does not look like it is continually eating the same foods, besides the way of preparation, is to avoid that the same foods are always present.

This is where the prime numbers intervene and their property to be divisible only by themselves and unity. That is to say those two prime numbers have no other common divisor than the unit. To do this it will be introduced the tables 1, 2 and 3, where it will have different foods groups of the FP.

To simplify will take A01, A02 and A03 of the first group (GI); B04, B05, B06, B07 and B08 of the second group (GII) and C09, C10, C11, C12 and C13 of the third group (GIII), understanding that it should eat foods from the GI and GII every day. And although it should eat foods of the GIII less frequently, as it is assumed that they are also consumed every day.

And although an analysis of cost will not do, also it will be assumed that the food is arranged in ascending form with regard to his costs that is to say $A01 < A02 < A03 < B04 < B05 < B06 < C07 < C08 < C09$, where $<$ it will be read that the food on the left is of lower cost than the one on the right.

In the Table 1, the illustration will appear for foods only of GI and of the GII, when of the GI they will be prepared every two days and those of the GII every three days. In the table 1, just as in the following tables, to facilitate the accounting of the days, it is begun with the day 00 and the numbers between parentheses next to the food that represents the last group, it means the times that the food of this line has prepared for themselves in joint form.

Table 1: Food consumption of the GI and GII, alternating every two and three days respectively.

Day	GI	GII	Day	GI	GII	Day	GI	GII
00	A01	B04 (1)	11	A02	B06 (2)	22	A01	B05 (4)
01	A02	B05 (1)	12	A01	B04 (3)	23	A02	B06 (4)
02	A01	B06 (1)	13	A02	B05 (3)	24	A01	B04 (5)
03	A02	B04 (1)	14	A01	B06 (3)	25	A02	B05 (5)
04	A01	B05 (1)	15	A02	B04 (3)	26	A01	B06 (5)
05	A02	B06 (1)	16	A01	B05 (3)	27	A02	B04 (5)
06	A01	B04 (2)	17	A02	B06 (3)	28	A01	B05 (5)
07	A02	B05 (2)	18	A01	B04 (4)	29	A02	B06 (5)
08	A01	B06 (2)	19	A02	B05 (4)	30	A01	B04 (6)
09	A02	B04 (2)	20	A01	B06 (4)			
10	A01	B05 (2)	21	A02	B04 (4)			

In this Table 1, with the lowest possible frequencies, since the first two prime numbers are used, every two days for the GI and three days for the GII, all foods are consumed together only five times, except foods A01 and B04 that if consumed on day thirty-one would be consumed six times together. This although that the food of the GI consumes fifteen times during the month and the food of the GII is consumed ten times during the month and as already said A01 and B04 are consumed once more each. The foregoing, makes one think that it is interesting to see how the situation varies if it is using a frequency slightly higher. In other words, foods of the GI are prepared every three days and the GII every five days, as reflected in the Table 2.

Table 2: Food consumption of the GI and GII, alternating every three and five days respectively.

Day	GI	GII	Day	GI	GII	Day	GI	GII
00	A01	B04 (1)	11	A03	B05 (1)	22	A02	B06 (2)
01	A02	B05 (1)	12	A01	B06 (1)	23	A03	B07 (2)
02	A03	B06 (1)	13	A02	B07 (1)	24	A01	B08 (2)
03	A01	B07 (1)	14	A03	B08 (1)	25	A02	B04 (2)
04	A02	B08 (1)	15	A01	B04 (2)	26	A03	B05 (2)
05	A03	B04 (1)	16	A02	B05 (2)	27	A01	B06 (2)
06	A01	B05 (1)	17	A03	B06 (2)	28	A02	B07 (2)
07	A02	B06 (1)	18	A01	B07 (2)	29	A03	B08 (2)
08	A03	B07 (1)	19	A02	B08 (2)	30	A01	B04 (3)
09	A01	B08 (1)	20	A03	B04 (2)			
10	A02	B04 (1)	21	A01	B05 (2)			

In this Table 2, even with low frequencies, 3 and 5 very interesting numbers are achieved, since all foods are consumed together only twice, except foods A01 and B04 which if used on day thirty-one will be consumed three times together. Although GI foods are consumed ten times during the month and GII foods are consumed six times a month and as already said A01 and B04 are consumed once more each.

It remains to be seen how the behavior will be if instead of two groups it works with three groups, for this purpose, in the Table 3 shows the case when GI foods are prepared every two days, GII foods every three days and GIII foods every five days.

In the Table 3, they have only been indicated in parentheses when there is a coincidence of three foods. The coincidences between frequencies of two against three and of three against five have already been obtained from previous tables and of them it can be deduced that the coincidences with frequencies of two against five are three and with a case of four, which corresponds to the day thirty one; it leaves this check for readers. Since it was possible to know by intuition, not repeated matches of three foods, except for A01, B04, and C09, which will coincide on the day thirty-one. And note again, that the GI foods are consumed fifteen times during the month, while those of the GII, ten occasions and of the GIII, six times, except, again, A01, B04 and C09, to be consumed once additional.

Table 3: Food consumption of GI, GII and GIII, alternating two, three, and five days respectively.

Day	GI	GII	GIII	Day	GI	GII	GIII	Day	GI	GII	GIII
00	A01	B04	C09 (1)	11	A02	B06	C10 (1)	22	A01	B05	C11 (1)
01	A02	B05	C10 (1)	12	A01	B04	C11 (1)	23	A02	B06	C12 (1)
02	A01	B06	C11 (1)	13	A02	B05	C12 (1)	24	A01	B04	C13 (1)
03	A02	B04	C12 (1)	14	A01	B06	C13 (1)	25	A02	B05	C09 (1)
04	A01	B05	C13 (1)	15	A02	B04	C09 (1)	26	A01	B06	C10 (1)
05	A02	B06	C09 (1)	16	A01	B05	C10 (1)	27	A02	B04	C11 (1)
06	A01	B04	C10 (1)	17	A02	B06	C11 (1)	28	A01	B05	C12 (1)
07	A02	B05	C11 (1)	18	A01	B04	C12 (1)	29	A02	B06	C13 (1)
08	A01	B06	C12 (1)	19	A02	B05	C13 (1)	30	A01	B04	C09 (2)
09	A02	B04	C13 (1)	20	A01	B06	C09 (1)				
10	A01	B05	C09 (1)	21	A02	B04	C10 (1)				

From here it can infer, that if it uses higher frequencies, such as might be three, five and seven for three food groups would not matches during the month. Even if it will only work with two groups and frequencies of five and seven, there will be no repetitions.

Following these last comments can be presented some conclusions.

CONCLUSIONS AND FUTURE INVESTIGATIONS

In this work there appeared evidences, which allow to conclude that the prime numbers have fascinated the man from very remote epochs, however, there are very few practical applications of the same and, in particular, that play an important role in the daily life. With the desire to search for applications of the primes that reach the common man paid attention to two interrelated aspects: the Food pyramid (FP) and the Diet problem (DP). Both were made brief comments and showed what it is their relationship, fulfilling one of the specific objectives of the work.

Taking these two concepts, FP and DP, as a starting point, a series of three tables were presented, through which it could be illustrated, that following an appropriate sequence, oriented by the prime numbers, it can be achieved that in a household, food preparation is perceived less repetitive. Thus achieving the general objective of the work. Having done the illustrations with the first prime numbers, allows to conclude that as larger prime numbers are used, the repetitions of food groups will be practically null. This application of the prime numbers in the daily tasks of the kitchen, allows to recommend, extend these applications to other routine household tasks or in the programming of sports training routines, Just to mention a couple of fields, where it may be interesting to apply prime numbers in everyday life.

ACKNOWLEDGMENTS

This investigation would not have been possible without the support given by: Minimax Consultores, C.A., through its Research Management.

REFERENCES

- Andrade, J. C. (2013). Hilbert-Pólya conjecture, Zeta functions and Bosonic Quantum Field theories. *International Journal of Modern Physics A* 1350072, 28(17), 1-6.
- Barreto O., E. A., G. J. Hernández G., M. J. García G. & J. G. Hernández R. (2016). *Security & Safety (S&S) and the Logistics Business*, Proceedings ICIL2016, AGH University of Science and Technology in Krakow, Krakow, Poland, 12-23.
- Chakrabarty, P. (2012). A Simple formula to predict the number of primes. *International Journal of Scientific & Engineering Research*, 3(1), 1-2.
- Chen, Ch., Lin, H. & Gun, Ch. (2012). A novel distributed RSA blind and weakly undeniable multi-signature scheme. *International Journal of Innovative Computing, Information and Control*, 8(10(A)), 6975-6998.
- Dantzig, G. B. (1990). The diet problem. *Interfaces*, 20(4), 43-47.
- França, G. & LeClair, A. (2015). Transcendental equations satisfied by the individual zeros of Riemann ζ , Dirichlet and modular L-functions. *arXiv preprint arXiv:1502.06003*, 1-51.
- García G., M. J., Hernández G., G. J. & Hernández R., J. G. (2014). A Methodology of The Decision Support Systems applied to other projects of Investigation, In Mehdi K. (Ed.), *Encyclopedia of Information Science and Technology*, Third Edition: Hershey, PA: IGI Global, V3, 1978-1990.
- García G., M. J., Hernández G., G. J. & Hernández R., J. G. (2015). *An approach to the ranking of projects to undertake*. In A. Cobos & A. Vanti (Ed), *Gobernanza empresarial de Tecnología de la Información*, Santander, España: Universidad de Cantabria, 427-441.
- Garille, S. G. & Gass, S. I. (2001). Stigler's diet problem revisited. *Operations Research*, 49(1), 1-13.
- Graham, R. L., Lagarias, J. C., Mallows, C. L., Wilks, A. R. & Yanb C. H. (2003). Apollonian circle packings: number theory. *Journal of Number Theory*, 100, 1-45.
- Gueye, I. (2013). Conjecture in additive twin primes numbers theory. *The Bulletin of Society for Mathematical Services and Standards*, 2(1), 53-60.
- Hernández R., J. G., García G., M. J. & Hernández G., G. J. (2016). Enterprise diagnosis and the Environmental manager of LoMoBaP. *Journal of Global Business and Technology*, 12(1), 60-76.
- Jeny, A., Hernández, J. G., García, M. J. & Hernández, G. J. (2015). *Generation and Knowledge Management System Through the information and networks manager*, In Delener et al. (Eds.), Seventeenth annual International Conference Global Business And Technology Association, Reading Book: USA, GBATA, 244- 251.
- Kabwe, T. Ch (2015). Introducing a new standard formula for finding prime numbers. *International Journal of Mathematics Trends and Technology*, 25(1), 59-109.
- Latorre, J. I., & Sierra, G. (2014). There is entanglement in the primes. *arXiv: 1403.4765 [quant-ph]*, 1-31.
- Leterme, P. (2002). Recommendations by health organizations for pulse consumption. *British Journal of Nutrition*, 88(S3), 239-242.
- Li, N., Helleseth, T., Tang, X. & Kholosha, A. (2013). Several new classes of bent functions from Dillon exponents. *IEEE transactions on information theory*, 59(3), 1818-1831.

- Loebenberger, D. (2012). *Grained integers and applications to cryptography*, Doctoral dissertation, Bonn University, Bonn, Germany.
- Mazur, B. (2012). *Primes, knots and Po*. In Lecture notes for the conference 'Geometry, Topology and Group Theory' in honor of the 80th birthday of Valentin Poenaru, 1-16.
- Menezes, G. & Svaiter, N. F. (2013). Quantum field theories and prime numbers spectrum. *arXiv preprint arXiv:1211.5198*, 1-10.
- Menezes, G., Svaiter, B. F. & Svaiter, N. F. (2013). Riemann zeta zeros and prime number spectra in quantum field theory. *International Journal of Modern Physics A* 1350128, 28(26), 1-18.
- Mesnager, S. & Flori, J. P. (2012). A note on hyper-bent functions via Dillon-like exponents. *IACR Cryptology ePrint Archive*, 1-48.
- Naraghi H. & Naraghi H. (2012). The determination of the number of distinct Fuzzy subgroups of group $Z_{p_1 \times p_2 \times \dots \times p_n}$ and The dihedral group $D_{2 \times p_1 \times p_2 \times \dots \times p_n}$. *International Journal of Mathematical Archive*, 3(4), 1712-1717.
- Neuhauser, L., Rothschild, R. & Rodríguez, F. M. (2007). MyPyramid.gov: assessment of literacy, cultural and linguistic factors in the USDA food pyramid web site. *Journal of nutrition education and behavior*, 39(4), 219-225.
- Oehlschlägel, J. (2014). Reasoning about Primes (I). *arXiv preprint arXiv:1405.5996*, 1-63.
- Padmaja, Ch. J. L., Bhagavan, V. S. & Srinivas, B. (2016). RSA encryption using three Mersenne primes. *International Journal of Chemical Sciences*, 14(4), 2273-2278.
- Pollicott, M. (2015). *Apollonian Circle Packings*. In Fractal Geometry and Stochastics V, volume 70 of Progress in Probability, 121-142.
- Tang, C., Li, N., Qi, Y., Zhou, Z. & Hellesteth, T. (2016). Linear codes with two or three weights from weakly regular bent functions. *IEEE Transactions on Information Theory*, 62(3), 1166-1176.
- Tang, C. & Qi, Y. (2013). A new class of hyper-bent functions and Kloosterman sums. *IACR Cryptology ePrint Archive*, 870, 1-21.
- Von Ruesten, A., Illner, A. K., Buijsse, B., Heidemann, C. & Boeing, H. (2010). Adherence to recommendations of the German food pyramid and risk of chronic diseases: results from the EPIC-Potsdam study. *European journal of clinical nutrition*, 64(11), 1251-1259.
- Walter, P., Infanger, E. & Mühlemann, P. (2007). Food pyramid of the Swiss Society for Nutrition. *Annals of Nutrition and Metabolism*, 51(Suppl. 2), 15-20.
- Xu, G., Cao, X. & Xu, S. (2015). Several new classes of Boolean functions with few Walsh transform values. *arXiv preprint arXiv: 1506.04886*, 1-15.
- Yu, L., Liu, H. & Zheng, D. (2015). On more bent functions from Dillon exponents. *Applicable Algebra in Engineering, Communication and Computing*, 26(4), 389-408.

A BUSINESS MODEL FRAME FOR INNOVATIVE STARTUPS

Dante Jorge Dorantes-Gonzalez
MEF University, Turkey

ABSTRACT

Current business model frames such as the Business Model Canvas and the Lean Canvas do not address aspects of open innovation, problem statement, innovative problem solving, business metrics and disruptive strategies; therefore, a novel business model frame is introduced to cover these aspects. This new model is based on a combination of key principles of the theory of inventive problem solving applied to business and management, such as multi-screen analysis of value-conflict mapping, trends of ideality of business system evolution positioning, among others; but also, intellectual property, disruptive strategies, and open innovation, as well as startup metrics to describe the business differentiation and attractiveness to potential investors, incubators and accelerators. The entrepreneur designing his/her own startup should be able to justify if not all, most of the items to be able to demonstrate the idea strengths. And regarding both building blocks “Product Formulation and Inventive Problem Solving” and “Disruption Strategy”, certain training should be necessary.

Keywords: Business model, innovation, TRIZ, intellectual property.

INTRODUCTION

A business model usually consists of three steps, such as, thinking about the opportunity to satisfy a real customer who needs a job to be done; sketch how the company will fulfill the need at a profit; and compare that model to an existing model to see how much it should be changed to capture the opportunity (Johnson, 2008). On the other hand, a business model consists of a four-block frame that creates value of any business: Customer value proposition, profit formula, key resources, and key processes: Customer value proposition (CVP), profit formula, key resources, key processes.

In order to effectively map out business models, Osterwalder (2004) created the Business Model Canvas. Afterwards, Maurya (2010, 2012) generated the Lean Canvas. These schemes are the most important models that sketch the main business model concepts. Both focus on problems, top priorities, solutions, key metrics (key activities) and competitive advantages, as well as capture the information of a traditional business plan in a single page.

The Business Model Canvas is a single page model that includes items such as: Key partners, key activities, key resources, value propositions, customer relations, channels, customer segments, cost structure and revenue streams (Fig. 1).

Figure 1: The Business Model Canvas Frame

Key Partners	Key Activities	Value Propositions	Customer Relations	Customer Segments
	Key Resources		Channels	
Cost Structure			Revenue Streams	

Unlike the Business Model Canvas, the Lean Canvas includes: The “Unfair Advantage”, which is a quality that can’t be easily copied or bought; “Key Metrics” refers to the key activities; the rest of the items are similar to the ones of the Business Model Canvas (Fig. 2). The left half of the frame relates to the product, and the right half to the market.

Figure 2: The Lean Canvas Frame

Problem	Solution	Unique Value Propositions	Unfair Advantage	Customer Segments
	Key Metrics		Distribution Channels	
Cost Structure			Revenue streams	

The advantages of both schemes are that after their completion, the riskiest parts of the business can be quickly identified, so that one can collecting data about those areas to test most fundamental aspects of the model, so to be able to return to the model and update it over and over based on new findings, and finally, help coming up with the key things that matter most (Merrill, 2015). Both models are addressed to general startups, but they have left behind from the point of view of including a more systematic approach for the evaluation of innovative startups.

ENHANCING THE BUSINESS MODEL WITH INNOVATION

Being critical to the Business Model Canvas and the Lean Canvas, both models do not refer to important aspects of startups that usually matter to investors, incubators and accelerators (Dorantes-Gonzalez, 2015) such as: (1) Open innovation approaches; (2) Disruption strategy; (3) Startup financial, user, marketing, sales and market metrics.

In the present paper, besides reaffirming the previous three items in a frame based on the Business Model Canvas, a further development of the statement of the unique value proposition is made; moreover, the application of the Theory of Inventive Problem Solving (TIPS, or from its Russian transliteration: Теория Решения Изобретательских Задач, TRIZ) to the business model frame is proposed.

Open Innovation Approaches

The benefits of open innovation have been well known even before coining the term Open Innovation was coined in 2003 (Steiner, 2014): DuPont’s TechnologyBank™ eased spreading its own technology licenses to become industry standards; IBM’s Ventures in Collaboration program helped entrepreneurs to adopt its patented technology, as well as supplied its software in open source license with the interest of linking the enterprises to IBM technologies; Intel has relayed on the extensive use of external knowledge with universities, labs, and venture capital; Procter & Gamble opened internal research to outside participants to improve internal collaboration and to detect and adapt patented technologies from external actors, doubling its rate of innovation success and decreasing costs.

Open innovation is “the use of purposive inflows and outflows of knowledge to accelerate internal innovation and to expand the markets for external use of innovation, respectively” (Chesbrough, 2006). Open innovation is usually contrasted with closed innovation, supposedly its predecessor, where companies generate their own innovation ideas, and then develop, build, market, distribute, service, finance, and support them on their own (Chesbrough, 2003). However, Chesbrough enabled both academics and practitioners to rethink the design of innovation strategies in a networked world, coinciding with the current interest for outsourcing, core competences, collaboration, and the internet. He also connected the processes of acquiring external knowledge and exploiting internal knowledge externally by placing them both under the open innovation umbrella.

Based on the openness of both the process and the outcome of innovation, open and closed innovation is categorized by Huizingh (2011) as: (1) Private open innovation (Huston, 2006); (2) In-house closed innovation (Chesbrough, 2003); Open source innovation (von Hippel, 2010); (4) Public innovation (von Hippel, 2006).

Disruption Strategy

Disruption strategies usually involve new ways to improve customer satisfaction; finding opportunities by understanding change trends; developing abilities to move quickly and surprise by being the disrupter, not the disruptee; changing the rules of the game; investing in strategic market communication, and attacking with several competitive weapons simultaneously (D'Aveni, 1999); watching and anticipating competitors' plans and think five moves ahead; and keeping a finger on the pulse of your customers as early-warning, allowing to react to market changes (Myler, 2013). More accurate disruption approaches that often require business model change into an unknown market and business model territories, were listed by Johnson (2008):

1. Democratize products in emerging markets at the Bottom of the Pyramid. Address through disruptive innovation the needs of large potential customer groups who are shut out of a market entirely because existing solutions are too expensive or complicated for them.
2. Threat low-end core markets, such as the Indian cheap car Nano, threatening other automobile makers.
3. Deploy a new business model around a brand-new technology or bring a tested technology to a whole new market.
4. Fulfill an entirely unmet customer service where that does not yet exist, especially in markets where existing products tend to increase commoditization over time, by integrating its key processes and resources in a vastly more efficient way.
5. Turn commoditized products into services, i.e. rather than selling products at lower and lower prices, sell a "just-the-product-you-need-when-you-need-it, no-repair-or-storage-hassles" service.

It is also worth to mention to this context the "12 Dimensions of Business Innovation" or also called, the "Innovation Radar", which can be used to look for opportunities to innovate. This innovation radar consists of four key dimensions: The offering, the customers, the processes and the points of presence the company uses to take its offering to market (Sawhney, 2006). Within these four core dimensions there are 8 more described as follows: (1) Offerings (innovative new products or services); (2) Platform (common components or building blocks to create derivative offerings); (3) Customized end-to-end solutions; (4) Unmet customer needs or underserved customer segments; (5) Customer experience interaction across all touch points and moments of contact; (6) Value capture, redesigning how company gets paid or create innovative new revenue streams; (7) Core operating processes to improve efficiency and effectiveness; (8) Change the form, function or activity scope of the firm; (9) Supply chain sourcing and fulfillment; (10) Create new distribution channels or innovative points of presence, including places where offerings can be bought or used by customers; (11) Create network-centric intelligent and integrated offerings; (12) Leverage a brand into new domains.

Startup Metrics

When raising capital from investors, it is significant to demonstrate a quick and clear executive evaluation of the startup's performance for the venture capitalists or stakeholders, since they just accept or reject the proposal without a clear understanding of the factors that influenced the decision. Metrics are very informative about the various dimensions of a startup's performance. Even though metrics are not usually sufficient to guarantee an outcome, they are necessary to successfully fundraise. At the end of the day, investors want to know why it is safer to invest in a product.

A venture capital investor guide of the most important metrics analyzed when judging an early-stage startup is divided in five groups: financial, user, acquisition, sales, and marketing (Crichton, 2014):

1. Financial Metrics: Monthly Revenue Growth, Revenue Run Rate, Gross/Net Margins, Burn Rate and Runaway.

2. User Metrics: Daily Active Users / Monthly Active Users, K-value (Virality), Proportion of Mobile Traffic, Cohort Analysis and Churn.
3. User Acquisition and Marketing Metrics: Cost of Acquiring a Customer and Payback (paid and free channels), Net Promoter Score.
4. Sales Metrics: Magic Number, Basket Size (Average Sales Price) and Order Velocity, Average Sales Cycle, Long Term Value.
5. Market Metrics: Total Addressable Market, Average Wallet Size.

Further Improvement of the Unique Value Proposition

The unique value proposition is a differentiating factor that would compel a prospect to choose a specific company over a competitor. This item is central, and it is insufficiently stated. Some tips for identifying a unique value proposition and stand out in a competitive market are pointed out by Lord (2014), Sinek (2014) and Murphy (2013):

1. Critical focus and features. Why it's so critical for the prospects, and how focused the company is on this.
2. Partnerships and platform integrations. Show off how convenient and powerful a platform is when integrated with other products of value to prospects.
3. Customer service. If competitors are standing on low prices as their unique value proposition, invest in a customer-service team, which can be a great way to stand out.
4. Design, user interface and user experience. Make the experience of discovery, comparison, decision, easy use and understanding, and ongoing user experience stunning. People are willing to pay for quality and a beautiful design.
5. Focus on the "why" of the Golden Circle Theory. The best companies focus on "why" they do what they do, getting at the heart of introducing prospects to the core values and motivations for building this product and sharing it with the world. Innovative enterprises think and act by communicating from inside out, by explaining what their beliefs, purpose, inspiration and cause are; hence inspiring, building trust, loyalty, so justifying why we should care (Sinek, 2014). For Sinek, "Why" means "what is your purpose and believe? Why does your organization exist? Why should everybody care? Why is what we trust, are loyal to, our cause, purpose and believe in challenging the status quo (Murphy, 2013).
6. Spin your price in your favor. If you cost more, then it costs more because it comes with account management, development cost, scales better, more reliable, or better customer service? Whatever the reason, put it front and center and explain that price delta.

Applying the Theory of Inventive Problem Solving's Tools to the Business Model Definition

It is well known for disruptors and innovators that evaluating technologies in a completely unrelated industry may bring chances to revolutionize our industry in the future. This is what TRIZ is meant. The Theory of Inventive Problem Solving (TIPS or, from Russian, TRIZ-Teoriya Resheniya Izobretatelskikh Zadach) is becoming one of the leading practices at large and small industrial companies in the world to support innovation and intellectual property by solving inventive problems and generate breakthrough ideas. In its origins, TRIZ was created for technical systems (Altshuller, 1988), however, it has been successfully applied in arts (Murashkovsky, 2007), advertisement (Vikentiev, 2007), social problems (Altshuller, 1994), business and management (Souchkov, 1998; Mann, 1999). Even though TRIZ has been used specifically for business model innovation (Ishida, 2003; Gomila, 2009), both papers dealt with a vague definition of a business model. Lou (2009) used the separation principles to solve physical contradictions for business model innovation of enterprises. However, only Souchkov (2010) proposed a more structured approach based on business modelling:

- Ideality/Value formula in Business Models.

$$\text{Degree of Ideality} = \frac{\text{Value Creators of the Value Proposition} - \text{Value Reducers}}{\text{Harmful Functions} + \text{Costs}}$$
- Contradictions and Value-Conflict Mapping (business vs market / technology requirements). These are contradictions between growing market and customer demands that impose limits on value propositions.

Separation principles to solve physical contradictions are: separation in space, separation in time, phase transformation (separation on condition), system transformation (separation of parts from the whole). TRIZ provides a number of tools to help overcoming identified contradictions and the psychological inertia by using the available resources and separation principles. Some developments using these tools are:

- Root Conflict Analysis, RCA, (Souchkov, 2007)
- TRIZ-based Function Analysis (Mann, 2004; Souchkov, 2009)
- Multi-Screen or the 9-window Analysis to get a "big picture" of key driving contradictions across several system levels (Souchkov, 2009)
- Special version of the Contradiction Matrix and 40 Inventive Principles developed for business and management applications (Mann, 2004)
- 7 generic principles of conflicts elimination (Souchkov, 2009)
- The adapted version of Inventive Standards and the Trends of Business Systems Evolution can be used for more complex cases (Souchkov, 2009)
- Trends of Business Systems Evolution. Some trends of business evolution can be applied to building block of a business model, such as the Trend of Increasing the Degree of Dynamics, while some other trends address more specific building blocks, such as the trend of Customer Purchase Focus Evolution, addressing the Value Proposition and Revenue Streams (Mann, 2004; Souchkov, 2009). The Trend of Increasing Customer Expectations comprises: commodity, product, service experience, user experience, and individuals-targeted custom products.
- Building Block Patterns. Each building block has its own content, depending on the type of business, product, service etc. At the same time, each building block can include generic patterns which can be reused across different business domains. For instance, in (Osterwalder, 2010) the following patterns are identified for the "customer relationship" building block: Personal assistance, dedicated personal assistance, self-service, automated service, communities, co-creation.

As a contribution to the application of TRIZ in Business Model, the author also recommends to use the following TRIZ tools: (1) Ideal Final Result; (2) Dynamization and Adaptability Increase; (3) Trend of Functionality Increase. In the following section, these key aspects will be integrated in the design of a new business model frame.

DESIGN OF A NEW BUSINESS MODEL FRAME

On the basis of the business model canvas, aforementioned topics can be integrated into it. The new proposals are highlighted in red color in Fig. 3. This frame represents an further improvement to the frame presented in (Dorantes-Gonzalez, 2015).

Figure 3: The Proposed Business Model Frame

Key Partners, Open Innovation & IP	Problem/Product Formulation & Inventive Problem Solving	Value Propositions* & The why of the Golden Circle	User Experience & Customer Relations*	Customer Segments*
	Key Activities (strengths)	Disruption Strategy	Distribution Channels*	
	Key Resources & IP Policy			
Cost Structure			Revenue streams*	

* means that key Startup Metrics may be included. The shaded section means the introduction of a brand new item to the model.

Fig. 4. shows a detailed guide to answer each of the sections of the new business model frame. There are two new building blocks created within this frame related to “Product formulation and inventive problem solving” and “Disruption Strategy”, which is shaded in red color. Regarding the building blocks “Product Formulation and Inventive Problem Solving” and “Product formulation and inventive problem solving”, certain training should be

necessary to fill in these blanks. In a further research, the applications of the present business model frame for innovative startups will be shown in detail.

Figure 4: The Proposed Business Model Frame

<p>Key Partners</p> <p>Crowdsource</p> <p>Intellectual Property (IP) Policy</p> <p>Type of Open Innovation</p>	<p>Product formulation and inventive problem solving:</p> <p>Situation Analysis (needs, demands, expectations of business owners/executives); Problem/opportunity/constraint formulation; Ideality/Value formula; Function Value Analysis; Multi-Screen or the 9 windows; Analysis of Value-Conflict Mapping; Contradiction Matrix and 40 Inventive Principles for business & managt.; 7 generic principles of conflict elimination; Inventive Standards and Trends of ideality of business system evolution; Trend of Functionality Increase; Ideal Final Result; Dynamization and Adaptability Increase</p>	<p>Value Propositions</p> <p>Critical focus and features</p> <p>Partnerships and platform integrations</p> <p>Customer service</p> <p>Design, user interface and user experience</p> <p>Focus on the “why” of the Golden Circle Theory</p> <p>Spin the price in our favor</p>	<p>Customer Relations</p> <p>User Experience Feedback</p> <p>User Metrics: Daily Active Users / Monthly Active Users, K-value (virality), Proportion of Mobile Traffic, Cohort Analysis and Churn</p>	<p>Customer Segments</p> <p>Market Metrics: Total Addressable Market, Average Wallet Size</p>
	<p>Key Activities</p>	<p>Disruption strategy:</p> <p>Democratize products in at the Bottom of the Pyramid</p> <p>New business model around a new technology or tested technology on a new market</p> <p>Fulfilling an unmet customer service where that does not yet exist</p> <p>Fend off low-end disrupters</p> <p>Leading core market segments to commoditize (turning products into a service)</p>	<p>Distribution Channels</p> <p>Sales & Marketing Strategies</p> <p>Sales Metrics: Magic Number, Basket Size (Average Sales Price) and Order Velocity, Average Sales Cycle, Long Term Value</p> <p>User Acquisition and Marketing Metrics: Cost of Acquiring a Customer and Payback (paid and free channels), Net Promoter Score</p>	
<p>Cost Structure</p>		<p>Revenue Streams; Profit Formula; IP Policy benefits; Financial Metrics: Monthly Revenue Growth, Revenue Run Rate, Gross/Net Margins, Burn Rate and Runaway</p>		

CONCLUSION

Current business model frames such as the Business Model Canvas and the Lean Canvas do not address aspects of open innovation, problem definition, innovative problem solving, business metrics and disruptive strategies; therefore, a novel business model frame is introduced to cover these aspects. This new frame is addressed to startup entrepreneurs, incubators, accelerators and investors interested in supporting these new companies. Besides Open Innovation Approaches, Disruption Strategy, Startup Metrics, the new business model frame adds a refinement of the statement of the unique value proposition, and introduces tools of the Theory of Inventive Problem Solving. The entrepreneur designing his/her own startup should be able to justify if not all, most of the items to be able to demonstrate the idea strengths. And regarding both building blocks “Product Formulation and Inventive Problem Solving” and “Product formulation and inventive problem solving”, certain training should be necessary to fill in these blanks. But the learning is worthwhile.

REFERENCES

- Altshuller, G. 1988, "Creativity as an Exact Science", Gordon & Breach, New York.
- Altshuller, G., Vertkin, I. 1994, "How to Become a Genius: Life strategy of creative personality", Minsk, Belarus (In Russian)
- Chesbrough, H.W. 2003, “Open Innovation: The New Imperative for Creating and Profiting from Technology”, Harvard Business School Press, Boston.
- Chesbrough, H.W., Vanhaverbeke, W., West, J. (Eds.), 2006. Oxford University Press, London.
- Crichton, D. 2014, “The Complete Quantitative Guide To Judging Your Startup”, techcrunch.com, Jan 31, 2014, <http://techcrunch.com/2014/01/31/the-complete-quantitative-guide-to-judging-your-startup/>
- D'Aveni, R.A. (1999) Strategic Supremacy through Disruption and Dominance, Sloan Management Review; Cambridge, Mass.40.3 (Spring 1999): p. 127
- Dorantes-Gonzalez, D.J., Küçükaydın, H., Özlem, Ş., Bulgan, G., Aydın, U., Son Turan, S., Karamollaoglu, N., Teixeira, F.F. 2015, “Improved Business Model Representation of Innovation Concepts”, Proceedings of the 2015 World Conference on Technology, Innovation and Entrepreneurship, Istanbul, Turkey, May 28-30.
- Gomila, J. 2009, "Prospecting New Business Models with TRIZ", in Proceedings of TRIZCON-2009, March 16- 18, California, USA.
- Huizingh, E.K.R.E. 2011, “Open innovation: State of the art and future perspectives”, Technovation 31 (1), pp. 2–9.
- Huston, L., Sakkab, N. 2006, “Connect and develop: inside Procter & Gamble's new model for innovation” Harvard Business Review 84, pp. 58–66.
- Ishida, A. 2003, "UsingTRIZtoCreateInnovativeBusiness Models and Products", in Proceedings of ETRIA TRIZ Future 2003, November 12-14, 2003, Aachen, Germany.
- Johnson, M.W., Christensen, C.M., Kagermann, H. 2008, “Reinventing Your Business Model”, Harvard Business Review, December 2008. <https://hbr.org/2008/12/reinventing-your-business-model/ar/1x>
- Lou Yonghai, Li Jianhua, Business Model Innovation of Enterprises by Physical Contradiction Means of TRIZ, International Conference on Electronic Commerce and Business Intelligence, ECBI 2009, 6-7 June 2009, IEEE Xplore, pp. 529-532, 2009.

- Lord, J. 2014, "Want to Stand Out From the Crowd? Know Your Unique Value Proposition", Entrepreneur, April 09, 2014. <http://www.entrepreneur.com/article/232893>
- Mann, D., Domb, E. 1999, "40 Inventive (Management) Principles With Examples," The TRIZ Journal, September, www.triz-journal.com
- Mann D. 2004, "Hands-on Systematic Innovation for Business and Management", Lazarus Press.
- Maurya, A. 2010, "Practice Trumps Theory, How to Document Your Business Model On 1 Page", August 11, 2010. <http://practicetrumpstheory.com/businessmodelcanvas/>
- Maurya, A. 2012, "Practice Trumps Theory, Why Lean Canvas vs Business Model Canvas?" February 27, 2012. <http://practicetrumpstheory.com/why-lean-canvas/>
- Merrill, C. 2015, "Business Plans. Skip the Boring Business Plan. Focus on This Strategy Instead", Entrepreneur, February 06, 2015. http://www.entrepreneur.com/article/242452?utm_source=pocket&utm_medium=email&utm_campaign=pockethits
- Murashkovsky, Y. 2007, "Biography of Arts", Scandinavia, Petrozavodsk (In Russian)
- Murphy, J. 2013, "Why Do You Do What You Do?" 09/06/2013. http://www.huffingtonpost.com/john-murphy/why-do-you-do-what-you-do_b_3873650.html
- Myler, L. (2013) 4 Ways To Create A Disruptive Business Strategy, Forbes Entrepreneurs Retrieved on September 4, 2013 <https://www.forbes.com/sites/larrymyler/2013/09/04/4-ways-to-create-a-disruptive-business-strategy/#794f0c13546f>
- Osterwalder, A., 2004. The Business Model Ontology: A Proposition in the Design Science Approach, unpublished dissertation, University of Lausanne.
- Osterwalder, A., Pigneur, Y. 2010, "Business Model Generation: A Handbook for Visionaries, Game Changers, and Challengers", Wiley.
- Sawhney, M, Wolcott R.C., Arroniz, I., (2006) The 12 Dimensions of Business Innovation, MIT Sloan Management Review, p. 78
- Sinek, S. 2014, "How great leaders inspire action", TED 2014, http://www.ted.com/talks/simon_sinek_how_great_leaders_inspire_action#t-198730
- Souchkov, V. 1998, "M-TRIZ: Application of TRIZ to Solve a Business Problem," white paper, Insytec.
- Souchkov, V, Hoeboer, R., van Zutphen, M. 2007, "Application of Root-Conflict Analysis (RCA+) to Solve Business Problems", The TRIZ Journal, February 2007, www.triz-journal.com
- Souchkov, V. 2009, "A Guide to TRIZ and xTRIZ Techniques and References: A Course Book for Business and Management". ICG T&C.
- Souchkov, V. 2010, "TRIZ and Systematic Business Model Innovation", Global ETRIA Conference 'TRIZ Future 2010', Bergamo, Italy, November 3-5.
- Steiner, A. 2014, "Élaboration et Mise En Oeuvre D'un Modèle Organisationnel Favorisant L'open Innovation: Contribution à L'innovation Collaborative", Thesis, Université de Lorraine

Vikentiev, I. 2007, "Principles of Advertisement and Public Relations", TRIZ-Chance and Business Press, St. Petersburg (In Russian)

von Hippel, E., von Krogh, G. 2006, "Free revealing and the private collective model for innovation incentives", R&D Management 36 (3), pp. 295–306.

von Hippel, E. 2010, "Comment on "Is open innovation a field of study or a communication barrier to theory development?" Technovation 30, 555.

MANAGING WORK INTEGRATED LEARNING STRENGTHS, OPPORTUNITIES AND RISKS IN THE EMERGING SOUTH AFRICAN ENVIRONMENT

Cookie M. Govender and Marius Wait
University of Johannesburg, South Africa

ABSTRACT

It is critical for the current rapidly changing education, government and business environments that training providers provide practical application to enhance theoretical learning in education, training and development programs. There is a need for effective and efficient work integrated learning (WIL) project leaders who aim to develop future-fit graduate or employee skills and competencies. Empirical research was conducted to identify, confirm and present the strengths, opportunities and risks (weaknesses and threats) in WIL projects in the emerging South African context. The qualitative research method entailed a classical two round Delphi technique and inductive content analysis. The key findings reveal that WIL project strengths include gaining a competitive advantage, forging industry partnerships and creating employment opportunities. Key weaknesses include the lack of a WIL project strategy, having limited skills and a lack of marketing competencies. Key opportunities include enhancing a diverse range of skills, creating new markets and further study with WIL. A key threat is the changing landscape. The theoretical contribution of this study is that it adds to the body of knowledge on WIL projects in South Africa, Africa and other developing economies. The research contribution is the use of the Delphi technique to gain validated consensus on WIL project management criteria. The practical contribution lies in the WIL SWOT matrix that can be utilized by WIL project leaders, managers and administrators to effectively and efficiently evaluate their WIL and other education, training and development projects.

Keywords: work integrated learning (WIL); WIL project; South Africa; SWOT; manage.

INTRODUCTION

Business, government, economies and societies benefit from the effective and efficient leadership, management and administration of projects; especially education, training, development and work integrated learning (WIL) projects. Increased productivity results from effective and efficient recruitment of skilled graduates, increasing organizational performance, resulting in increased benefits for all. Thus organizations gain a competitive advantage over competitors by identifying and managing the strengths, opportunities and risks in their WIL projects, providing them with growth opportunities for interaction in the local, national and international marketplace (du Plessis & Van Niekerk, 2014). Measuring and managing the return on investment of learning and development projects by identifying the strengths, opportunities and risks of these projects lead to effective project management and the effective recruitment, engagement and retention of talent within organizations (Buckley, 2016).

Due to the globalization of markets, talented people are mobile and attracted to organizations that provide talent development via workplace learning and WIL projects. All countries require training providers, leaders, managers and administrators to ensure that WIL projects link theory to practice, build skills and competencies, and increase employability and performance of graduates and employees for workplace excellence (Reinhard, Pogrzeba, Townsend & Pop, 2016).

Literature trends reveal that there is a gap in knowledge with limited empirical research studies on how WIL projects are managed (Chong, 2014; Jacobs & Dzansi, 2015), both in the workplace and by education and training providers, especially in developing or emerging economies (Khampirat & McRae, 2017). South Africa (SA) is an emerging economy that thrives on job creation, employability and entrepreneurship opportunities, largely due to its high unemployment rate, especially amongst graduating youth. The research question for this study focused on the criteria and factors WIL project leaders and managers employ to manage and evaluate WIL projects. The research purpose was to identify, confirm and present the common strengths, weaknesses, opportunities and threats (SWOT) of WIL projects in the emerging South African context. For the purpose of this paper, risks will be presented as the weaknesses and threats.

This study contributes to theory, research and practice. On a theoretical level, the contribution of this study lies in the additional body of knowledge on the SWOT of WIL projects in SA. The empirical evidence on WIL project management in South Africa contributes to new knowledge creation for Africa and other developing economies. On a research level, the study contributes in the use of the qualitative classical Delphi technique to gain consensus on WIL project management SWOT criteria. On a practical level, the WIL SWOT matrix resulting from this study is a project management tool that WIL project leaders, managers and administrators will find useful to effectively and efficiently evaluate their WIL and other education, training and development projects.

This paper presents the introduction, recent literature trends on WIL project management, the research method employed to conduct this study, the significant findings of the study, a discussion of the findings, the implications and applications of the findings, and the conclusion with recommendations for further research.

LITERATURE REVIEW

The current trends in the literature are presented under these subheadings: WIL in South Africa; WIL project management in emerging countries; and analyzing the SWOT of WIL projects.

WIL in South Africa

Work integrated learning or WIL in South Africa does not differ much from the international or global definition (Reinhard *et al.*, 2016). WIL is described as the workplace practice that accompanies theoretical or classroom learning. Service learning, work-based learning, cooperative learning, learnerships and internships are related concepts to WIL but differ with regard to the duration and specific period in which the working experience is implemented. For higher education students in SA, the Higher Education Act governs WIL. WIL is recommended for implementation in all modules of learning in all qualifications; however, not all university curricula have a WIL component (Coetzer & Sitlington, 2014; Jacobs & Dzansi, 2015).

The aim of WIL in South African universities is to provide students with workplace experiential learning so that graduates entering the world of work are recruited as high quality talent who have a balance of theoretical and practical knowledge (Taylor & Govender, 2017). Multiple stakeholders are involved in projects and curricula that provide WIL experience. Key stakeholders include the students, educator, employer and government (Wait & Govender, 2016). While the student takes responsibility for placement, experiential learning and WIL assessments; educators are responsible for integrating WIL into the curricula and inviting industry and other stakeholders to the WIL project. Employers or organisations enter into agreements with students as providers of the WIL experience while gaining the opportunity to observe potential future talent (du Plessis & Van Niekerk, 2014; Wilson & Pretorius, 2017).

The responsibility of government in the WIL project is often unclear, especially as the policy advocator in the form of learning, development and training opportunities for youth, graduates and employees (Amadi-Echendu, Phillips, Chodokufa & Visser, 2016). A variety of partnerships can be forged with government, especially if funding and other resources are required for the WIL project. Educator partnerships with business and industry are often more

successful than partnerships with government due to the many risks associated with state protocol, poor leadership, administrative delays and financial mismanagement (Govender & Taylor, 2015; Rajwee & Naidoo, 2015).

WIL project management in emerging countries

WIL projects across most developed countries of the globe provide quality workplace learning programs to meet economy, educator, government and business strategies. WIL projects in emerging economies aim to do the same yet face various risks and challenges (Turcotte, Nichols & Philipps, 2016). While educators and business partners in developing country WIL projects seem more committed to exploring experiential learning opportunities, students and government seem reluctant. National quality assurance bodies need to demonstrate that resources being spent on WIL projects; yet there is little evidence that those resources are utilized effectively for achieving institutional, employer and student goals (Khampirat & McRae, 2017).

Ideally WIL projects in emerging countries should be regulated by quality standards and policy frameworks for implementation, assessment and outcomes management (Clark, 2014). WIL project management is concerned with student readiness for the workplace, educator-industry partnerships, quality of placement, student and manager perceptions and WIL assessment (Reinhard *et al.*, 2016). There is limited evidence of the management of quality standards, strategy, policy, procedures, monitoring, measurement, evaluations and reviewing of the effectiveness WIL models and projects (Khampirat & McRae, 2017). Developing global standards, policy frameworks and quality integrated WIL models will enhance the effectiveness and efficiency of WIL projects, especially in emerging economies and developing countries.

WIL in some BRICS and other developing economies are geared to co-create social and economic justice by providing for informal and formal apprenticeships (Liebenberg, 2015); provide lifelong learning skills and competencies (Duke, 2015); and encourage organisational knowledge management via establishing communities of practice (Buckley, 2016). Emerging market WIL projects seem to be designed to create future-fit, employable graduates ready for the knowledge economy. Job and employment creation is the top priority of countries such as South Africa; hence WIL partnership models are popular as it encourages and cements relationships with business and government (Govender & Taylor, 2015; Maharaj & Mason, 2016).

Analyzing the SWOT of WIL projects

A SWOT (strengths, weaknesses, opportunities and threats) analysis is a common tool used in the world of work and business. It is used mostly to evaluate the impact of project inputs, processes, people, cost, time, outputs and outcomes, especially in terms of maximising strengths and future opportunities and managing risks. SWOT analysis is also effectively used in evaluation research to undertake these goals: gather and analyse stakeholder contributions; understand the leadership and management perceptions; and to draw operational conclusions from projects and programs (Govender & Taylor, 2015; Romero-Gutierrez, Jimenez-Liso & Martinez-Chio, 2016; Wait & Govender, 2015; Taylor & Govender, 2017).

The use of the SWOT analysis to evaluate WIL projects or educational programs is however very limited (Clark, 2014). Romero-Gutierrez *et al.* (2016) used the SWOT analysis to evaluate a postgraduate master's degree in environmental education through student perceptions. The study made use of an online SWOT open-ended questionnaire and obtained 44 student feedback reports. Data was subjected to content analysis and the researchers concluded that the use of the SWOT analysis with a Likert rating scale clearly identified the strengths, weaknesses, opportunities and threats of this educational program.

Jain and Pant (2010) used a SWOT analysis to evaluate the environmental management system of the TERI University in New Delhi. The SWOT analysis identified the major environmental concerns of the university in order to develop an environmental policy and plan. In 2000, a SWOT was used to evaluate Asian education. The published general guidelines led to a SWOT matrix for their educational sector. This matrix identified 12 strengths, 13 weaknesses, 10 opportunities and 9 threats (Lee, Lo, Leung & Sai On Ko, 2000; Lee & Sai On Ko, 2000). This SWOT matrix was adapted and used for the purpose of conducting the current empirical research conducted in South Africa.

Parrage, Conzales-Cancelas & Soler-Flores (2014) provides guidelines on the use of the SWOT analyses as a WIL evaluation strategy as follows: consolidate the strengths of those factors that enhance the WIL project reputation, outputs and economic contribution to country and continent; minimize the weaknesses of those factors that cause an unfavourable position for the project and include resources, skills and activities that do not develop students positively; maximize the opportunities of those factors that are positive, favourable and exploitable allowing for a competitive advantage; and reduce the threats of those risk factors of the project that work against ultimate successful performance of the project.

RESEARCH METHOD

The research method section of this paper presents the research design, participants and sample, instruments and procedure, analysis and ethical considerations.

Research design

The research design employed a multi-phased qualitative approach to gain consensus on WIL project evaluation criteria. The Delphi technique and inductive content analysis formed the basis of the design. This research study is embedded in the constructivist paradigm. The ontology is that reality is the lived truth. The epistemology is that knowledge is co-created by researchers and research participants who are specialists, professionals and practitioners of WIL in SA. The axiology is based on the fact that the values and judgements of participants become the accepted truth.

Research participants and sample

The research population consisted of the WIL Project Leaders of the 23 public higher education institutions or universities in SA. A purposively selected sample population of 5 universities with a targeted 40 WIL project leaders, managers and administrators as specialists in the field formed the sample population. Only 12 participant responses were included in the final analysis yielding a response rate of 30%. This is considered to be an effective, acceptable, reliable and valid sample size for this research design (Lee & Sai On Ko, 2000).

Research instrument and procedure

The classical Delphi technique (Coetzer & Sitlington, 2014; Abery, Drummond & Bevan, 2015; Field, Yates, Koppi, McBratney & Jarrett, 2017) was employed with a two round circulation to allow for data saturation. Criteria for WIL project management was extracted from the literature in the categories of WIL project strengths, weaknesses, opportunities and threats (Lee, Lo, Leung & Sai On Ko, 2000; Lee & Sai On Ko, 2000).

Participants were requested to use a 7-point Likert agreement scale (1=strongly disagree; 7=strongly agree) to indicate to what extent they agreed or disagreed with the SWOT criteria that they would use when undertaking a strategic SWOT analysis or evaluation of their WIL projects.

Research analysis

The analysis involved collating the results and compiling the criteria for the SWOT analysis from the averages of each of the SWOT matrix criteria. The principle for inclusion or exclusion for the SWOT matrix was based on the 7-point Likert scale. All criteria between 4.5 and 7 were included and deemed as agreed to by all participants for inclusion in the SWOT matrix. With 4 being the midpoint or neutral point, all criteria with 4 or nearest to 4 were deemed to be neutral, namely ratings of 3.5 to 4.4.; and hence included in the second round of Delphi, yet excluded from the final SWOT matrix. All criteria between 1 and 3.4 were deemed as disagreed with by the panel and hence excluded.

The initial SWOT matrix consisted of 20 strengths, 13 weaknesses, 9 opportunities and 8 threats. Inductive analysis of the weighting allocated to the rating scale allowed for the averages of the matrix to be calculated. The final

WIL project SWOT matrix consisted of the following criteria: 15 strengths, 11 weaknesses, 8 opportunities and 4 threats. For the purpose of this paper, these criteria were synthesized into these key SWOT factors: 3 strengths, 3 weaknesses, 3 opportunities and 1 threat.

Ethical considerations

Ethical clearance was secured for the research study from the institution of the researchers. The research participants were invited to participate and they provided consent for their participation in this study. Participants were assured of their anonymity and confidentiality. Participant responses were allocated unique numbers to ensure that their identities were protected. The data gathered was used for research and development purposes only.

FINDINGS

The research findings are presented under these subheadings: strength factors of WIL projects; weakness factors of WIL projects; opportunity factors of WIL projects; and threat factor of WIL projects.

Strength Factors of WIL projects

After analysis, three key strength factors of the WIL projects in SA were extracted from 15 strength criteria as follows: having a competitive advantage (7), establishing collaborative partnerships (6) and promoting employment skills (2). The competitive advantage factor was derived from seven criteria. The collaborative partnerships factor was derived from six criteria. The employment creation factor was derived from two criteria. Table 1 presents the three strength factors with a description of their criteria.

Table 1: WIL Strength Factors and Criteria

Strength	Total Criteria	Description
1. Competitive advantage	7	Advantage over other local HEIs; less competitive pressure; good operational strategy; policy & strategy; WIL Project Leader; innovative WIL project; financial resources.
2. Collaborative partnerships	6	Industry partnerships; preferred WIL partners; recognition for other HEIs; community partners; government grants; sponsored resources.
3. Employment creation	2	Sustainable WIL project; sustainable employment.

Weakness Factors of WIL projects

The analysis found three key weakness factors for WIL projects in SA as extracted from 11 weakness criteria as follows: lack of WIL project strategy, limited skills and average marketing ability. The lack of strategy factor was derived from five criteria. The limited skills factor was derived from two criteria. The average marketing factor was derived from four criteria. Table 2 presents the three weakness factors with a description of their criteria.

Table 2: WIL Weakness Factors and Criteria

Weakness	Total Criteria	Description
1. Strategy	5	Lack a good strategy; internal operating challenges; immobility of WIL project; industry-HEI misalignment; limited research & development.
2. Limited skills	2	Build limited student skills; Inexperienced WIL Project Leader.
3. Average marketing ability	4	Limited marketing & exposure; employment competitiveness; recurrent need for resources; weak image.

Opportunity Factors of WIL projects

The analysis revealed three key opportunity factors for WIL projects in SA as extracted from eight opportunity criteria as follows: providing diverse skills, options of new markets and further study and WIL. The diverse skills factor was derived from four criteria. The new markets factor was derived from three criteria. The further study and WIL factor was derived from one criterion. Table 3 presents the three opportunity factors with a description of their criteria.

Table 3: WIL Opportunity Factors and Criteria

Opportunities	Total Criteria	Description
1. Diverse skills	4	Students gain diverse skills; global skills; WIL project is trans & multidisciplinary; aligned to emerging trends.
2. New markets	3	Emerging markets in Africa & BRICS; transfer WIL project to other HEIs; aligned to national & international imperatives.
3. Further WIL and study	1	Ability for further WIL & future study.

Threat Factor of WIL projects

After analysis, only one key threat factor emerged for the evaluation of WIL projects in SA as extracted from four threat criteria as follows: changing landscape. The changing landscape factor was derived from four related criteria. Table 4 presents the threat factor with a description of its criteria.

Table 4: WIL Threat Factor and Criteria

Threat	Total Criteria	Description
1. Changing landscape	4	Changing stakeholder needs; new competitors; adverse government policies; advancing technology.

DISCUSSION

This empirical study aimed to identify and present the WIL SWOT matrix derived for the evaluation of South African WIL projects. The aim was achieved successfully using the qualitative Delphi and inductive content analysis instruments. The findings are significant for universities, training providers, business, government, other partners, as well as for South Africa, Africa, BRICS countries and globalization. Figure 1 presents the overview of the WIL SWOT matrix with the key factors.

Figure 1: SWOT Matrix Factors for WIL Project Evaluation



(Source: Authors)

The first key strength factor indicates that WIL projects should aim to gain a competitive advantage over other similar institutional WIL by empowering students with employability skills using an operationally sound WIL project guided by legislation and policy. Furthermore, having a reputable WIL project leader with innovative abilities and adequate financial and other resources allows the WIL project to gain a competitive advantage. This strength factor is a significant finding for the country, especially for comparisons with WIL projects in other emerging countries and economies. The second key strength factor identified collaborative partnerships with industry, other universities, local community and government as significant for shared resources, especially financial resources. The third key strength factor identified employment skills as significant to the sustainability and success of the WIL project, especially with regard to students gaining employment readily due to the project.

The first key weakness factor, the lack of a WIL strategy, is significant. This finding reveals that WIL projects fail due to not having a clear strategic direction, experiencing operational problems, inflexible WIL project, misaligned to partnership strategies, and a lack of WIL project research and development. The second significant key weakness factor is that the WIL project provides a limited range of primary and secondary skills to students and the WIL project leader has a limited range of skills. This factor can and should be managed with the assistance of the collaborative partners. The third weakness factor of average marketing ability is highly significant to increasing partnerships, competitive advantage and employability. Without a good, loud public image, the WIL project does not gain credibility, competitiveness or resources, especially financial investments.

The first key opportunity factor is that WIL projects can provide a range of diverse skills to students for discipline specific, communication, management and other skills sets. Students with a diverse set of skills can compete in other emerging countries, BRICS economies and the global marketplace. Hence, the second key opportunity factor is that new markets emerge for South African graduates to enter both locally and internationally due to the WIL project. WIL projects are ideally placed to provide employment and further study options, including further WIL

experiences; hence the third opportunity factor of further learning is significant for the emerging country, continent and world.

There is only key threat factor, changing landscape, identified for SA WIL projects; yet it is highly significant finding. A changing landscape is a norm in developing countries such as South Africa, especially with regard to changing stakeholder needs, new competitors, adverse government policies and changing technology. In SA, this finding alerts WIL managers to the threat of unintended and unforeseen changes due to external factors and partners. This finding is definitely common to all BRICS and other developing countries and probably also common to the changing global environment.

Although significant findings emerged from this empirical research, this study also faced a few limitations. Only a small sample of the SA public higher education institutions was used; hence generalizability is compromised. The participant sample does not include all industry sectors and affects inference of these WIL SWOT factors and criteria onto all sectors of the economy. There was limited empirical research knowledge on the use of the Delphi technique to analyze the WIL SWOT criteria which could have comprised the analysis.

IMPLICATIONS FOR MANAGERIAL APPLICATION

The findings of this study have positive implications for application, especially for the leaders, managers and administrators of WIL projects in SA, BRICS and other emerging economies and developing countries. The WIL SWOT factors and criteria in the form of the WIL SWOT matrix enable WIL projects to be evaluated and improved quickly and easily. On evaluation, WIL project managers can maximize their strengths and opportunities, and minimize their weaknesses and threats.

The implications of this research study and its findings for SA, Africa and BRICS countries are that it presents credible evidence of WIL project strengths, weaknesses, opportunities and threats similar to those of other developing countries. SA may not be at the forefront of WIL provision; yet there is evidence that WIL projects are evaluated with the will to improve them.

The implications for global WIL projects and policy are that the WIL SWOT matrix may provide a useful tool for WIL evaluation policy as well become a tool for comparisons between countries. Furthermore, other countries may become informed of what to expect when engaging in WIL projects in the SA environment.

CONCLUSION

This paper presented the empirical research conducted to validate WIL SWOT criteria to evaluate and improve WIL projects in South Africa. In order to extract the key WIL SWOT factors and provide a WIL SWOT matrix for SA, adapted international WIL project criteria were subjected to a Delphi consensus with local participants. The findings indicate that there are three key SWOT factors for WIL project strengths, weaknesses and opportunities, with only one significant threat factor. All factors are consistent with a developing country context where the landscape changes rapidly, new markets are available, competition is high, employment is a priority, partnerships are collaborative, and diverse skills are an advantage.

This paper also presents the significance of these findings to South Africa, Africa, BRICS countries and the global marketplace. If WIL projects are of high quality where the strengths and opportunities are maximized and the risks (weakness and threats) are managed and minimized, they can attract global markets and organizations as WIL partners, providing international employment for talented, future-fit graduates.

The recommendation is for further research to be conducted to empirically validate the WIL SWOT matrix and its factors with selected participants of this study, by using it to evaluate selected WIL projects. Further research on whether the matrix, factors and criteria are aligned to other sectors in the developing SA, BRICS and other

emerging economies are recommended. It is only when WIL projects are evaluated, improved and enhanced to engage students and other stakeholders that it becomes instrumental as an effective and efficient change agent tool towards individual, business, government and socioeconomic upliftment.

REFERENCES

- Abery, E., Drummond, C., & Bevan, N. (2015). Work Integrated Learning: What do the students want? A qualitative study of Health Sciences students' experiences of a non-competency based placement. *Student Success*, 6(2), 87-91.
- Amadi-Echendu, A. P., Phillips, M., Chodokufa, K., & Visser, T. (2016). Entrepreneurial Education in a Tertiary Context: A Perspective of the University of South Africa. *The International Review of Research in Open and Distributed Learning*, 17(4).
- Buckley, S. (Ed.). (2016). *Organizational Knowledge Facilitation through Communities of Practice in Emerging Markets*. IGI Global.
- Chong, C. S. (2014). Service-Learning Research: Definitional Challenges and Complexities. *Asia-Pacific Journal of Cooperative Education*, 15(4), 347-358.
- Clark, K. (2014). The Strengths and Weaknesses of a "Learning While Earning" Variation of Work-Integrated Learning. *International Journal of Quality Assurance in Engineering and Technology Education (IJQAETE)*, 3(4), 52-65.
- Coetzer, A., & Sitlington, H. (2014). What knowledge, skills and attitudes should strategic HRM students acquire? A Delphi study. *Asia Pacific Journal of Human Resources*, 52(2), 155-172.
- du Plessis, H., & Van Niekerk, A. (2014). A new GISc framework and competency set for curricula development at South African universities. *South African Journal of Geomatics*, 3(1), 1-12.
- Duke, C. (2015). Lost soul or new dawn? Lifelong learning lessons and prospects from East Asia. *Journal of Adult and Continuing Education*, 21(1), 72-88.
- Field, D. J., Yates, D., Koppi, A. J., McBratney, A. B., & Jarrett, L. (2017). Framing a modern context of soil science learning and teaching. *Geoderma*, 289, 117-123.
- Govender, C. M., & Taylor, S. (2015). A Work Integrated Learning Partnership Model for Higher Education Graduates to Gain Employment. *South African Review of Sociology*, 46(2), 43-59.
- Jacobs, H., & Dzansi, D. Y. (2015). Finding a Work-integrated Learning Strategy that Enhances the Employability of Graduates of South African Universities of Technology: A Research Agenda. *Journal of Economics*, 6(2): 102-109.
- Jain, S. & Pant, P. (2010). An environmental management system for educational institute: A case study of TERI University, New Delhi. *International Journal of sustainability in Higher Education*. 11(3), 236 – 249.
- Khampirat, B., & McRae, N. (2017). Developing global standards framework and quality integrated models for cooperative and work-integrated education programs. *Asia-Pacific Journal of Cooperative Education*, 17(4), 349-362.
- Lee, S.F. & Sai On Ko, A. (2000) Building balanced scorecard with SWOT analysis and implementing "Sun Tzu's the art of business management strategies" on QFD methodology. *Managerial Auditing Journal*. 15, 1. P 68 – 76.

- Lee, S.F., Lo, K.K., Leung, R. & Sai On Ko, A. (2000) Strategy formulation for vocational education: integrating SWOT analysis, balanced scorecard, OFD methodology and MBNQA education criteria. *Managerial Auditing Journal*, 185/8, p 407 – 423.
- Liebenberg, A. (2015). 7.2. A quest for social justice: Exploring the possibility of expanding the South African apprenticeship system to provide access to informal apprentices. *Architectures for Apprenticeship*, 194.
- Maharaj, R., & Mason, R. B. (2016). An Exploratory Critique of Action Learning in Higher Education in South Africa: Barriers and Challenges. *International Journal of Educational Science*, 13(3): 298-309.
- Parrage, M.M., Conzales-Cancelas, N. & Soler-Flores, F. (2014) DELPHI-SWOT tools used in strategic planning of the Port of Manta. *Social and Behavioural Sciences*, Vol 162, 129-138.
- Rawjee, V.P. and Naidoo, P. 2015. A South African perspective of work-integrated learning and HIV/AIDS workplace orientation. *Journal of Human ecology*. 50(3): 271-280.
- Reinhard, K., Pogrzeba, A., Townsend, R., & Pop, C. A. (2016). A comparative study of cooperative education and work-integrated learning in Germany, South Africa, and Namibia. *Asia Pacific Journal of Cooperative Education*, 17 (3), 249-263.
- Romero-Gutierrez, M., Jimenez-Liso, R. & Martinez-Chio, M. (2016) “SWOT analysis to evaluate the programme of joint / onsite master’s degree in environmental education through the students’ perceptions.” *Evaluation and Programme Planning*, Vol 54, 41-49.
- Taylor, S., & Govender, C. M. (2017). Increasing employability by implementing a Work-Integrated Learning partnership model in South Africa—A student perspective. *Africa Education Review*, 1-15.
- Turcotte, J. F., Nichols, L., & Philipps, L. (2016). Maximizing Opportunity, Minimizing Risk: Aligning Law, Policy and Practice to Strengthen Work-Integrated Learning in Ontario. *Higher Education Quality Council of Ontario*, Canada.
- Wait, M., & Govender, C. M. (2016). Multi-stakeholder work integrated learning model for higher education—a transdisciplinary approach. *South African Journal of Higher Education*, 30(2), 279-293.
- Wilson, G., & Pretorius, R. W. (2017). Utilising Work-Integrated Learning to Enhance Student Participation and Engagement in Sustainability Issues in Open and Distance Learning. In *Handbook of Theory and Practice of Sustainable Development in Higher Education* (pp. 245-257). Springer International Publishing.

EXPLAINING CONSUMER ATTITUDE TOWARDS PURCHASING GREEN PRODUCTS: THE ROLE OF KNOWLEDGE, SELF-IDENTITY, AND UTILITY

Palesa T. Gule and Daniel K. Maduku
University of Johannesburg, South Africa

ABSTRACT

The purpose of this paper is to understand the impact of product knowledge, self-identity and product utility on the attitude of South African consumers towards buying 'green' products. A conceptual model that posited a direct relationship between product knowledge, self-identity, product utility and the attitude, was empirically tested using data that were conveniently sourced from consumers in Johannesburg, South Africa. A structural equation modeling (SEM) using SmartPLS, a partial least squares structural equation modelling (SEM) software package, was used to analyse the research framework proposed for this study. The results reveal that product knowledge, consumer self-identity and product utility were significant and positively related to consumers' attitudes towards green product purchases. The implications of the findings for the managerial development of appropriate marketing strategies aimed at improving consumers' attitudes towards green product purchases are outlined.

Keywords: Product Knowledge, Self-Identity, Product Utility, Attitude, Green Products, Johannesburg, South Africa.

INTRODUCTION

The global consumer is increasingly aware of and showing concern about the level of environmental degradation, as a result of the impact of globalisation and industrial development (Stolz, Molina, Ramírez & Mohr, 2013). Consumers are taking steps to educate themselves on what they believe are the benefits of being environmentally responsible citizens (Stolz *et al.*, 2013). Pro-environmental initiatives such as switching off lights whenever possible, recycling materials such as plastics and paper, using hot water boilers with thermostats, using borehole water and separating forms of waste into dedicated bins, are some of the steps consumers take in order to be environmentally friendly (Mbasera, Du Plessis, Saayman & Kruger, 2016). Some consumers also use reusable shopping bags whenever they go shopping as a way of showing concern for the environment (Karmarkar, & Bollinger, 2015). Other measures implemented by consumers to demonstrate their pro-environmental behaviour include buying organic products, products with less packaging and re-using or repairing items instead of throwing them away (Whitmarsh and O'Neill, 2010). Of all these measures, 'green consumption' is widely identified as most effective because, besides its pro-environmental benefits (such as water conservation and energy saving), consumers also derive good health benefits by consuming green products (Ottman, Stafford & Hartman, 2006).

Green consumption is therefore defined as any action aimed at preserving the environment. These include, but are not limited to, recycling, buying organic food, using environmentally friendly forms of transport purchasing products with green labelling and consuming fish and other species that have been produced by eco-friendly methods and that do not harm human health or prevent satisfaction of a genuine need (Ritter, Borchardt, Vaccaro, Pereira & Almeida, 2015).

Joshi and Rahmanb (2015) state that households can prevent environmental damage by buying green products. So it is vital to develop strategies that promote the consumption of green products among consumers. Consumers' attitudes to green product consumption is cited as a relevant factor in promoting their purchasing of green products (Sheth, 2011). It is important, therefore, to understand the notion of 'attitude' and the elements that have an impact on consumer attitudes towards the consumption of green products. Such understanding would help marketers

and producers to promote consumer habits, such as consuming green products that are less harmful to the environment (Ritter *et al.*, 2015). Moreover, for countries such as South Africa, that are heavily reliant on natural resources in supporting the economy, the issue of environmental preservation is key to its sustainability and consumers have a key role to play in driving the economy by consuming green products (Haywood, Brent, Trotter & Wise, 2010). Haywood, Brent, Trotter and Wise (2010) allude to the fact that it is important for producers, policy-makers and others interested in promoting a consumer culture of green consumption, to encourage a positive attitude towards it.

In spite of this there are limited studies, particularly in developing countries such as South Africa, that deconstruct 'attitude' in an attempt to understand the various factors that influence consumers' attitudes towards buying and consuming green products. The aim of this study is to understand the factors that influence consumers' attitudes towards green product purchasing among South African consumers. The findings of this study will not only contribute to the literature on the topic, but also provide important pointers for manufacturers, marketers, policy-makers and other responsible parties for creating positive consumer attitudes towards green product purchases.

RESEARCH MODEL AND HYPOTHESES

Attitude towards green products plays a key role in influencing or predicting a person's motivation for buying green products (Mohd Suki & Mohd Suki, 2016). A positive attitude is also regarded as the main predictor of intention to purchase green products (Han & Yoon, 2015). When consumers hold a positive attitude towards the environment, they are more likely to buy environmentally-friendly products, thus positively impacting the environment (Singh & Gupta, 2013).

This study examines the impact of selected variables such as, product knowledge, self-identity and product utility on the attitudes of South African consumers towards green product purchases. It proposes a conceptual model (Figure 1) that posits product knowledge, self-identity and product utility as direct antecedents of consumers' attitudes towards green product purchases.

Product Knowledge: Product knowledge can be described as the amount of information a consumer has about the benefits, dangers, features, functions, support and risks of using a product (Tseng, & Hung, 2013). The more knowledge people have about a product/service, the more likely they are to develop a positive attitude towards its purchase and the consumers' intention to purchase will be further enhanced through knowledge (Pagiaslis, 2014). Previous studies on green product consumption have emphasised that promoting consumers' knowledge about green products plays a key role in influencing their behaviour towards green consumption (Tseng and Hung, 2013). It is expected, that by providing ample information to consumers, so that they become knowledgeable about the benefits of the products and where to obtain them, it will have a positive influence on their attitudes towards green product consumption. Hence this study proposes that:

H1: Product knowledge will have a significant positive effect on consumers' attitudes towards green products use.

Self-Identity: Self-identity is the extent to which people perceive themselves as fulfilling a particular role in society (Dobson, 2017). This concept is widely considered to be an important factor influencing consumer attitudes towards a behaviour (Wang & Wang, 2016). Within the green marketing literature, self-identity has been identified as an important factor influencing green product consumption behaviour (Khare, 2014). Khare (2014) identified consumers' self-identification as a significant predictor of green purchasing behaviour. Therefore the following hypothesis was proposed for this study:

H2: Self-identity will have a significant positive effect on consumers' attitudes towards using green products.

Product Utility: Product utility underscores the key benefits that consumers derive from consuming a product. These benefits range from cost-saving, nutritional benefits health benefits and enhanced sensory experience to increased perceptions of product utility (Apaolaza, Hartmann, Echebarria & Barrutia, 2017). Moreover, product utility answers whether or not a customer can easily consume a certain product and whether or not it is easily available at a good price (Joshi & Rahman, 2015). The perceived utility of a product enhances or improves

consumers' attitude towards green product consumption. For this reason, this study proposes the following hypothesis:

H3: Product utility will have a significant positive effect on consumers' attitudes towards using green products.

RESEARCH METHODOLOGY

Measures: A self-administered survey questionnaire was used to obtain the data required to test the hypotheses. The questionnaire had two main parts. The first part of the questionnaire posed questions on the demographic characteristics of the sample and the second contained items measuring the main constructs of the study. These items were selected from previous literature and adapted to suit the current study. The five items used for measuring consumers' knowledge of green products were adopted from the study of Luo and Toubia (2015) and Pagiaslis and Krontalis (2014). The five items used to measure the utility of green products were adapted from the studies of Moser (2016) and Iyer, Davari and Paswan (2016). Lastly, the four items used to measure self-identity were selected and adapted from the studies of Moser (2016) and Yazdanpanah and Forouzani (2015). All of the items were measured on a five-point Likert type scale, with anchors ranging from 1 'strongly disagree' to 5 'strongly agree'.

Survey Design and Data Collection: The population of this study was consumers residing in Johannesburg, South Africa. This research made use of a non-probability sampling technique in the form of convenience sampling to obtain the respondents. The researcher visited work places, homes, restaurants, churches, schools, and shopping malls to solicit respondents. After explaining the purpose of the study to them and seeking their consent, they were given a paper-based questionnaire to complete. Respondents also had the choice of having the researcher read the questionnaire aloud to them and record their responses on the questionnaire. Of the 300 sample respondents contacted to participate in the study, 200 took part, representing an effective response rate of 67%.

DATA ANALYSIS AND RESULTS

The Statistical Package for Social Science (SPSS) version 24 and Smart PLS 3.2.6 software packages were the main statistical programmes used to analyse the survey data.

Descriptive Statistics: SPSS version 24 was used to analyse the descriptive statistics of the sample, the results of which are presented in Table 1. As stated in the table, 63 (31.5%) of the participants were males and 137 (68.5%) of the participants were females. This means that more than two-thirds of the participants were females. With regard to the age of the participants, the majority (34%) were between the ages of 25 and 32, followed by those over the age of 47 (21%). It is important to note that about two-thirds of those who participated in the study were below the age of 40. On the respondents' level of education, 49 (24.5%) were educated up to the high school level, 112 (56%) had undergraduate degrees and 39 (19.5%) had postgraduate degrees. This means that the respondents' level of education was reasonably high. The study also sought to obtain information on the monthly income of the participants. According to the information presented, the majority of the participants, 60 (24.5%), indicated that they had a monthly income of less than R10 000. This was followed by those who reported earning between 15 000 ZAR and 19 999 ZAR (25%). From the results it is evident that 73.5% of the participants earn less than 20 000 ZAR. Respondents were also asked to indicate whether they had used, or were currently using, green products. According to the results in Table 1, 109 (54.5%) of the participants reported using green products, while 91 (45.5%) had not used green products. This means that the number of participants who have had experience using green products is higher than those who have not.

Table 1: Descriptive statistics of the sample

	Frequency	Percentage
Gender:		
Male	63	31.5
Female	137	68.5
Age		
18 – 24	28	14.0
25 – 32	68	34.0
33 – 39	36	18.0
40 – 46	27	13.5
47+	41	20.5
Academic level of study		
Up to high school	49	24.5
Undergraduate	112	56.0
Postgraduate	39	19.5
Monthly income (ZAR):		
0 - 9999	60	30.0
10 000 – 14 999	37	18.5
15 000 – 19 999	50	25.0
20 000 – 24 999	17	8.5
25 000 – 29 999	8	4.0
30 000 – 34 999	9	4.5
35 000 – 39 999	4	2.0
40 000 and above	15	7.5
Bought or used any green product in the past?		
Yes	109	54.5
No	91	45.5

Structural equation modelling: Structural equation modelling (SEM), using SmartPLS 3.2.6, a partial least squares structural equation modelling (SEM) software package (Ringle, Wende & Becker, 2015), was used to analyse the research framework proposed for this study. Following the two-step approach recommended by Anderson and Gerbing (1988), the measurement model was assessed to confirm its convergent and discriminant validities.

In determining the convergent validity of the measurement model, the standardised factor loadings, Cronbach's alpha, composite reliability (CR) and average variance extracted (AVE) were examined. For convergent validity to be achieved, Hair, Black, Babin and Anderson (2010) recommend that the standardised factor loadings and AVE should be above 0.5 and that Cronbach's alpha and CR should be above 0.7. According to the results presented in Table 2 and Figure 1, the factors loadings of the various items range between 0.636 and 0.944, and the computed AVE values are between 0.577 and 0.807. The Cronbach's alpha values range between 0.762 and 0.941. Lastly, the computed CR values are between 0.844 and 0.954. All of these estimates are above their respective thresholds, thus confirming the convergent validity of the measurement model.

To test discriminant validity, the Fornell & Larcker (1981) procedure was implemented. According to this procedure, discriminant validity is said to be achieved when the square root of the AVE is greater than the inter-factor correlations. According to the results presented in Table 2, the square roots of the AVEs are higher than the inter-factor correlations. Thus, it is safe to conclude that the measurement model exhibited good discriminant validity.

Table 2: Convergent and discriminant validities

	Alpha	CR	(AVE)	1	2	3	4
1 Attitude towards use	0.918	0.942	0.803	0.896			
2 Consumer knowledge	0.940	0.954	0.807	0.428	0.898		
3 Product utility	0.841	0.886	0.612	0.578	0.474	0.782	

4	Self-identity	0.762	0.844	0.577	0.490	0.352	0.527	0.760
---	---------------	-------	-------	-------	-------	-------	-------	-------

Note: Diagonal values are the square root of the AVE of each construct; values below the diagonal are the inter-factor correlations coefficients

After confirming the validity of the measurement model, the structural model was examined to determine the significance of the structural paths, the path estimates and the R2 of the structural model. To ascertain the significance of the structural paths, a bootstrapping with 500 re-samples was conducted using SmartPLS. The t static of the paths was then examined to determine its significance. The results of these analyses are presented in Figure 1 and Table 3.

Figure 1: Measurement and structural model analyses

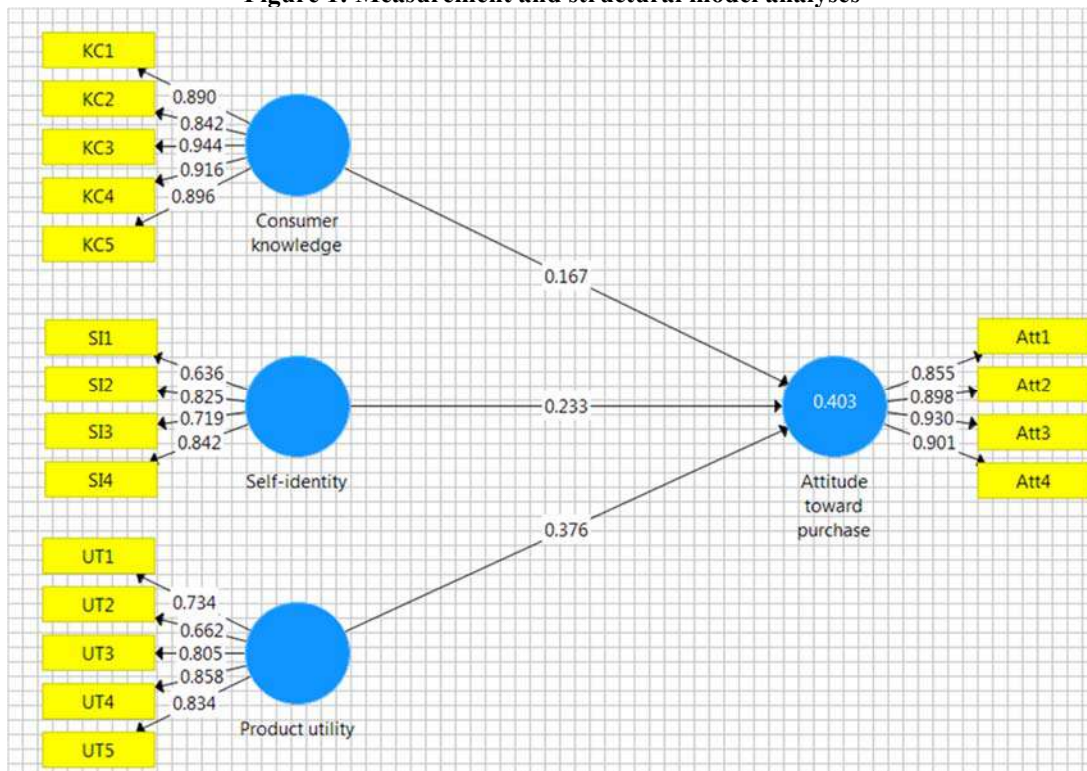

According to the results, the association between consumers' knowledge and their attitudes towards green products purchase is significant and positively related ($\beta = 0.167$, $t = 2.440$). These results provide support for H1. Furthermore, the results also suggest that consumers' self-identity has a significant positive effect on their attitude towards green products purchase, thus confirming H2. Concerning the relationship between green product utility and consumers' attitudes towards its use, the results of the analysis confirm a significant positive relationship between product utility and consumers' attitude towards green products purchase, thus confirming H3. Moreover, green product utility has the highest β value among the three factors, implying that it is the strongest determinant of consumers' attitudes towards green product purchase. The three significant factors together explain 40.3% of the variance in consumers' attitude towards green product purchase.

Table 3: Path analysis for structural model

Path	Path coefficient	T-Statistic
H1 Consumer knowledge → attitude toward purchase	0.167	2.440**
H2 Self-identity → attitude toward purchase	0.233	3.926*
H3 Product utility → attitude toward purchase	0.376	2.673
Attitude towards adoption		$R^2 = 40.3\%$

*Significant at $p < 0.01$; ** Significant at $p < 0.05$; *** Significant at $p < 0.10$

DISCUSSION AND RECOMMENDATION

The main aim of the study was to ascertain the effect of consumer knowledge, self-identity, and product utility on consumers' attitude towards buying green products. Data was obtained predominantly from a convenience sample of consumers residing in Johannesburg, South Africa. The findings suggest that the variables investigated have a significant and positive influence on consumers' attitude towards buying green products.

This study's finding – that consumer knowledge has a significant and a positive effect on their attitude toward buying green products – is consistent with the findings from previous studies that have consistently linked consumers' product knowledge with their positive attitude towards buying the product (Pagiaslis, 2014; Tseng & Hung, 2013). The findings of this study emphasise the need for managers to devote enough time and resources to creating awareness of the benefits of green product consumption if they are to succeed in creating a positive consumer attitude towards buying them. Specific information on product attributes – such as the health benefits, the health effects, the environmental benefits, and the potential economic benefits that can be generated as a result of this new economy – should be built into promotion strategies that are aimed at creating awareness that will lead to consumers' knowledge about green products, and should be emphasised (Wang & Wang, 2016).

The results of the study also suggest that self-identity has a significant positive effect on consumers' attitude towards green product purchases. This result validates the findings of previous studies that have found that self-identity and attitude towards product purchases are significant and directly related (Khare, 2014). A strong self-identity is related to a strong environmental, organic, and socially responsible attitude. Thus marketing strategies should underscore the promotion of a strong self-identity in relation to green consciousness. If consumers were led to regard themselves as 'green', this would impact on their attitude towards green purchases, strengthening their beliefs about environmental protection and undergirding their sense of a moral obligation to buy green products (Hustvedt & Dickson, 2009).

Finally, the study's findings on the significant direct association between product utility and attitude towards green product purchase is consistent with prior findings in the literature that have similarly identified a significant direct relationship between product utility and consumers' attitude towards their purchase (Joshi & Rahmanb, 2015). Managers hoping to generate a more positive attitude towards green products in their target market must first seek to increase the utility that consumers expect from consuming green products. In increasing the utility of green products, manufacturers must make sure that their products not only provide the health benefits sought by consumers, but that they also protect the natural environment, conserve energy, reduce pollution, and eliminate waste (Ottman *et al.*, 2006).

The findings of the study contribute to increasing our understanding of the factors that influence consumers' attitude towards green product purchases, and offer pointers to strategies that could be implemented to promote a positive consumers' attitude towards buying green products.

In spite of this, the study has limitations that impact on the generalisability of its findings. First, the study's design was cross-sectional in nature, and the sample was obtained using a non-probability procedure. For this reason, inferences cannot be made about causal relationships between the constructs in this study. Future studies could consider implementing longitudinal designs with data obtained through the probability sampling technique from a larger sample. Second, the data for the study were obtained from customers in Gauteng. Although this is the most populous province in South Africa, it is largely urban. Therefore the findings of this might not apply to consumers who live in the rural areas of the country. To improve upon the generalisability of this study, it would be important to consider improving the sample by including consumers living in rural areas.

REFERENCES

- Anderson, J. C. & Gerbing, D. W. (1988). Structural equation modeling in practice: A review and recommended two-step approach. *Psychological Bulletin*, 103 (3), 411-423.
- Apaolaza, V., Hartmann, P., Echebarria, C. and Barrutia, J. M. (2017). Organic label's halo effect on sensory and hedonic experience of wine: A pilot study. *Journal of Sensory Studies*, 32(1), 32-43.
- Dobson, A. (2017). Who am I? Self-identity – how to build personal character. Retrieved 19 April 2017 from: <http://www.mindfithypnosis.com/who-am-i-self-identity>.
- Fornell, C. & Larcker, D. F. (1981). Evaluating structural equation models with unobservable variables and measurement error. *Journal of Marketing Research*, 18 (1), 39-50.
- Hair, J. F., Black, W. C., Babin, B. J. & Anderson, R. E. (2010). *Multivariate data analysis: A global perspective* (7th ed.). New Jersey: Pearson Prentice Hall.
- Han, H. and Yoon, H. J. (2015). Hotel customers' environmentally responsible behavioral intention: Impact of key constructs on decision in green consumerism. *International Journal of Hospitality Management*, 45, 22-33.
- Haywood, L., Brent, A., Trotter, D. & Wise, R. (2010). Corporate sustainability: A social-ecological research agenda for South African business. *Journal of Contemporary Management*, 7, 326-346.
- Hustvedt, G. & Dickson, M. A. (2009). Consumer likelihood of purchasing organic cotton apparel: Influence of attitudes and self-identity. *Journal of Fashion Marketing and Management: An International Journal*, 13 (1), 49-65.
- Iyer, P., Davari, A. and Paswan, A. (2016). Green products: Altruism, economics, price fairness and purchase intention. *Social Business*, 6 (1), 39-64.
- Joshi, Y. & Rahmanb, Z. (2015). Factors affecting green purchase behaviour and future research directions. *International Strategic Management Review*, 3, 128-143.
- Karmarkar, U. R. & Bollinger, B. (2015). BYOB: How bringing your own shopping bags leads to treating yourself and the environment. *Journal of Marketing*, 79 (4), 1-15.
- Khare, A. (2015). Antecedents to green buying behaviour: A study on consumers in an emerging economy. *Marketing Intelligence & Planning*, 33 (3), 309-329.
- Luo, L. & Toubia, O. (2015). Improving online idea generation platforms and customizing the task structure on the basis of consumers' domain-specific knowledge. *Journal of Marketing*, 79 (5), 100-114.
- Mbasera, M., Du Plessis, E., Saayman, M. & Kruger, M. (2016). Environmentally-friendly practices in hotels. *Acta Commercii*, 16 (1), 1-8.
- Mohd Suki, N. & Mohd Suki, N. (2016). Green product purchase intention: Impact of green brands, attitude, and knowledge. *British Food Journal*, 118 (12), 2893-2910.
- Moser, A. K. (2016). Consumers' purchasing decisions regarding environmentally friendly products: An empirical analysis of German consumers. *Journal of Retailing and Consumer Services*, 31, 389-397.
- Ottman, J. A., Stafford, E. R. & Hartman, C. L. (2006). Avoiding green marketing myopia: Ways to improve consumer appeal for environmentally preferable products. *Environment: Science and Policy for Sustainable Development*, 48 (5), 22-36.

- Pagiaslis, A. & Krontalis, A. K. (2014). Green consumption behavior antecedents: Environmental concern, knowledge, and beliefs. *Psychology & Marketing*, 31 (5), 335-348.
- Ringle, C. M., Wende, S. & Becker, J.-M. (2015). SmartPLS 3. Retrieved 15 March 2017 from: <http://www.smartpls.com>.
- Ritter, A. M., Borchardt, M., Vaccaro, G. L., Pereira, G. M. & Almeida, F. (2015). Motivations for promoting the consumption of green products in an emerging country: Exploring attitudes of Brazilian consumers. *Journal of Cleaner Production*, 106, 507-520.
- Sheth, J. N., Sethia, N. K. & Srinivas, S. (2011). Mindful consumption: a Customer-centric approach to sustainability. *Journal of the Academy of Marketing Science*, 39 (1), 21-39.
- Singh, N. & Gupta, K. (2013). Environmental attitude and ecological behaviour of Indian consumers. *Social Responsibility Journal*, 9 (1), 4-18.
- Stolz, J., Molina, H., Ramírez, J. & Mohr, N. (2013) Consumers' perception of the environmental performance in retail stores: An analysis of the German and the Spanish consumer. *International Journal of Consumer Studies*, 37, 394-399.
- Teng, Y. M., Wu, K. S. and Liu, H. H. (2015). Integrating altruism and the theory of planned behavior to predict patronage intention of a green hotel. *Journal of Hospitality & Tourism Research*, 39 (3), 299-315.
- Tseng, S. C., & Hung, S. W. (2013). A framework identifying the gaps between customers' expectations and their perceptions in green products. *Journal of Cleaner Production*, 59, 174-184.
- Wang, Y. & Wang, C. (2016). Do psychological factors affect green food and beverage behaviour? An application of the theory of planned behaviour. *British Food Journal*, 118 (9), 2171-2199.
- Whitmarsh, L. and O'Neill, S. (2010). Green identity, green living? The role of pro-environmental self-identity in determining consistency across diverse pro-environmental behaviours. *Journal of Environmental Psychology*, 30 (3), 305-314.
- Yazdanpanah, M. & Forouzani, M. (2015). Application of the Theory of Planned Behaviour to predict Iranian students' intention to purchase organic food. *Journal of Cleaner Production*, 107, 342-352.
- Young, W., Hwang, K., McDonald, S. & Oates, C. J. (2010). Sustainable consumption: Green consumer behaviour when purchasing products. *Sustainable Development*, 18 (1), 20-31.

BUILDING LEADERSHIP CAPACITY IN A UNIVERSITY OF TECHNOLOGY: 360-DEGREE FEEDBACK AS A TOOL FOR PERSONAL AND INSTITUTIONAL TRANSFORMATION

Tessie H H Herbst
Tshwane University of Technology, South Africa

ABSTRACT

In order to effectively address the challenges higher education institutions are faced with, universities need academic managers who are not only credible scholars but also effective leaders. Self-awareness (defined as degree of agreement between self and subordinate ratings of leaders' behaviours) is essential to leadership effectiveness. In this regard, 360 degree feedback is a useful tool to assist managers to develop self-awareness by discovering their strengths, weaknesses and other qualities with regard to their current effectiveness from several viewpoints. In this work in progress research paper, the case analysis of a university of technology in South Africa, implementing 360-degree feedback as part of a leadership capacity building project has been done. A total of 88 managers participated in the 360-degree feedback process and they, in turn, were rated by a total of 699 raters which included his/her line manager, peers and subordinates.

Keywords: 360-degree feedback; self-awareness; leadership development; higher education; leadership capacity building.

INTRODUCTION

Everyone thinks of changing the world, but no one thinks of changing himself – Leo Tolstoy

Higher education institutions (HEI) are experiencing turbulent times and have no choice but to adapt and transform. Furthermore, Saunders (2016) states that “Academic leadership in higher education (HE) institutions has become increasingly challenging in rapidly changing global realities and is all the more complex in South Africa” (p. 1). The complexity of these challenges have profound implications for the leadership and management behaviour of managers within universities (Seale & Cross 2016), since they are the central ‘drivers’ of these change and transformation processes (Bendermacher, oude Egbrink, Wolfhagen & Dolmans, 2016). As a result managers within these institutions are left with no choice but to adapt and transform (Seale & Cross 2016).

As stated by Van Velsion and McCauley, (2004) the process of becoming a better leader is fundamentally grounded in personal transformation and self-discovery. In the same line Anderson and Adams (2016) state that personal transformation precedes organisational transformation. In order to achieve transformative change in universities, all stakeholders - especially leaders - need to move to a higher level of functioning. Blumenthal and Haspeslagh (1994) concur and argue that transformational change will result in behavioural change. From their perspective sustainable transformation simply means that the majority of employees have to change their behaviour. Without personal transformation any transformation will be temporary and “there is not organizational transformation without first transforming the consciousness of the leadership” (Anderson & Adams, 2016, p. 62). In other words, you cannot change what you are not consciously aware of (Jokinen, 2005). Understanding one’s strengths and weaknesses is regarded as essential for conscious personal transformation and development allowing personal

transformation to translate into cultural and systemic change. Gupta and Govindarajan (2002) maintain that the more explicitly self-aware we are, the more likely our current mind-set is to change.

One of the most effective ways to increase self-awareness is through 360-degree feedback (Atwater & Yammarino, 1992; Church, 1997; Herbst & Conradie, 2011; Van Velsor, Taylor & Leslie, 1993). The feedback process provides many insights, enabling individuals to gather information from different perspectives on their performance. According to Kets de Vries, Vrignaud, Florent-Treacy and Korotov (2007) a well-designed 360-degree (multi-source) instrument provides managers with a useful tool to develop self-awareness by comparing their self-perceptions with the observations from others within the work environment. MacKie (2015) argues that multi-source feedback is an intervention in itself when formally debriefed with the participant, even without subsequent leadership development. In the same line Kets de Vries and Korotov (2010) are of the opinion that the use of 360-degree feedback can assist leaders to achieve a transformational change by overcoming the internal barriers to effectiveness and to construct more productive relationships with key constituencies in the organisations. Kets de Vries and Korotov (2010) state it as follows: “To see ourselves as others see us is a great driver of change” (p. 10). It can assist managers to become more self-aware and set in motion changes in behaviour as a prerequisite for institutional transformation as described above. Leaders first need to change themselves in order to become more effective in helping others change. In this regard, self-awareness is essential to leadership effectiveness (Hernandez, Luthanena, Ramsela, Osatukea, 2015).

In this study the focus is on the use of 360-degree feedback as a tool for personal transformation. In general multi-source feedback is used mainly for improving self-awareness rather than as a means to assess the impact of leadership development interventions (MacKie, 2015). This process formed part of a leadership capacity building project amongst academic managers in a university of technology as a strategy for institutional transformation. The alignment or misalignment of leadership behaviour across hierarchical levels in the university may enhance or detract from the successful implementation of strategy (Chatman & Kennedy, 2010). Therefore, the aim of this project was to build collective leadership capacity amongst all academic managers within the system to communicate and connect, to drive change forward, to execute the strategic objectives and to align effort by using leadership development to leverage transformation. The 360-degree process will be repeated after completion of the LEAD (in-house leadership development programme) to assess behaviour change and alignment amongst managers.

The next section incorporates the reviewed literature in relation to the study, research design, results and analysis as well as conclusions and recommendations.

360-DEGREE FEEDBACK, SELF-AWARENESS AND LEADERSHIP EFFECTIVENESS

360-Degree Feedback

Multi-source feedback or 360-degree methodologies are a universal part of most leadership development programmes. The process entails systematically collecting both self-ratings of leadership behaviour as well as ratings for “significant others” (peers, subordinates, line managers) by means of a questionnaire. These multi-source ratings are used to assess the effectiveness of managers’ leadership behaviours. Various reasons exist for using a 360-degree approach, one of which is that individuals at different levels of the organisation are likely to observe different leadership behaviours. For example, in line with the socio-analytical view of leadership, behaviour can be divided into two dimensions: those motivated by a drive to get along and those motivated by a drive to get ahead (Hogan & Holland, 2003). Therefore, raters at different levels in the organisation each have a unique perspective in their assessment of a manager. Superiors being in a better position to rate behaviours and traits related to getting ahead, whereas subordinates and peers are more suitable to rate behaviours associated with getting along (Oh & Berry, 2009). Using a single-source rating may therefore fail to comprehensively capture these two distinct dimensions of leadership behaviour. Furthermore, single-source ratings have been criticised from the perspective of same-source bias (Oh & Berry, 2009) and also from a validity perspective, given the large number of studies that have reported incongruence in self-other ratings. Various studies (referred to in Detweiler-Bedell, Deitweiler-Bedell & Salovey, 2006; Herbst & Conradie, 2011) confirmed

that managers tend to overestimate their own leadership abilities and generally believe that their abilities and traits are above average.

Defining Self-awareness

Where self/other rater reports are concerned, such as those used in this study for 360-degree feedback, self-awareness is operationalized as self-other rating agreement (SOA) (Yammarino & Atwater, 1993). As such, self-awareness in this study is defined in line with the definition Fleenor, Smither, Atwater, Braddy and Sturm (2010), as the “degree of agreement between or congruence between a leader’s self-ratings and the ratings of others, usually colleagues such as superiors, peers, and subordinates” (p. 1005). Thus, the concept of self-awareness includes firstly, the image that an individual has of him/herself and secondly whether or not that image is accurate in comparison with how that individual is perceived by significant others in the work environment (Taylor, 2010).

Self-awareness and leadership effectiveness

As mentioned before, enhanced self-awareness is a prerequisite for personal transformation. As such, it leads to increased leadership effectiveness by enhancing leaders’ ability to monitor and adjust their own behaviour in order to ensure that their behaviour is aligned with and support organizational outcomes and transformation (Eid, Mearns, Larsson, Laberg, & Johnsen, 2012; Fleenor, Smither, Atwater, Braddy, & Sturm, 2010; Tiuraniemi, 2008). There is a well-established body of research which generally affirms the contention that self-awareness has a positive impact on leadership effectiveness (e.g. Atwater and Yammarino, 1992; Herbst & Conradie, 2011; Hernandez, Luthanena, Ramsela, Osatukea, 2015; Sosik, 2001; Taylor, Wang, & Zhan, 2012) and mediates supervisor burnout supervisor burnout (Hernandez, Luthanen, Ramsela & Osatukea, 2015). Besides implications for positive leadership behaviours, a recent study by Tang, Dai, and De Meuse (2011) also reveals a close relationship between self-other disagreements and leadership derailment behaviours. Additionally, Moshavi, Brown and Dodd (2003) provided evidence that the subordinates of leaders with higher SOA (reflecting high self-awareness) had significantly higher job satisfaction and satisfaction with supervision than did subordinates of leaders who overrated themselves. Overall, research (referred to in Hernandez, Luthanen, Ramsela & Osatukea, 2015) suggests that underrating oneself is associated with mixed outcomes (some positive and some negative); and overrating oneself is associated with primarily negative outcomes. Accurate self-ratings however, is associated with primarily positive outcomes.

METHOD

The Design of the 360-degree Instrument

As stated by Damian and Pitts (2015) context is a critical component of successful leadership. Although the notion that context and situational diversity have implications for leadership effectiveness it has a long history in the field of leadership theory and research (e.g. Fiedler 1967), this issue is hardly ever addressed. However, most leadership development programmes in higher education rest on the assumption that the same leadership style or skill sets are appropriate regardless of strategy or institutional culture. Kets de Vries and Korotov (2010) state that highly successful organisations have created contextualised leadership competency models to ensure that leaders are developed based on required skills and competencies to execute the strategy of the organisation. Typically the 360-degree process involve a competency questionnaire based on such a leadership competency model or success profile. For this purpose, the following four leadership competency clusters were identified in Phase one of the project to be related to effective leadership: *Collaborative change leadership*, *Strategy translation and innovation*; *Impactful relationship management* and *Disciplined results orientation*. In the questionnaire each of the four competency clusters are explained in terms of a definition and between seven and fifteen behavioural descriptors (See Table 1 as an example). These four clusters also form part of the university LEAD programme which is compulsory for all academic managers to attend.

Table 1: Competency cluster one - Collaborative change-leadership
DEFINITION: Changes and updates internal processes, systems and technologies in order to remain relevant. Reviews and openly debates current approaches. Deals constructively with any uncertainty and ambiguity around change. Assists colleagues in accepting and adjusting to changing conditions. Anticipates and adjusts to new challenges.
BEHAVIOURAL DESCRIPTORS:
Actively builds the reputation of the university / faculty / department
When I am with this person I feel part of a bigger vision I believe in
This leader can be trusted
Regularly reviews & openly debates the relevance of current approaches
Maintains composure in stressful conditions
When I am with this person I feel confident we can achieve our goals
Instils pride in the faculty / department amongst all staff
Builds consensus and support for initiatives among all stakeholders
Assists colleagues to personally accept and adapt to changes in TUT
Actively works to build a sense of unity in the faculty department
Is open and receptive to new ideas and different ways of doing things

The sum of the behavioural descriptors corresponding to each of the four leadership competence clusters gives rise to a forty four (44) statement questionnaire. The 360-degree instrument has been completely automated by means of an on-line system administered by an external service provider.

Each leadership competence cluster was measured by between seven and fifteen behavioural descriptions, rated on a 7-point Likert scale anchored by 'Seldom effective (1) up to 'Always a strength' (7). The 7-point rating scale was divided into the following three categories:

1 = Seldom Effective	Development area
2 = Sometimes Effective	
3 = adequately effective	
4 = Effective	Effective
5 = Very effective	
6 = Often a strength	Unusual strength
7 = Always a strength	

Cronbach's alpha reliability coefficient (α) conducted on the instrument have confirmed the reliability of the instrument. All four leadership competence clusters are reliably testing their respective latent constructs since their respective Cronbach's alpha values are greater than 0.7. The Cronbach's alpha values for each of the four competence clusters were as follows: Cluster one (0.7892); Cluster Two (0.7406); Cluster three (0.8226); and Cluster four (0.8020).

In line with the recommendation by Kets de Vries and Korotov (2010) that feedback should include rich verbal commentary and not be limited to numerical answers, raters were also asked to provide any specific feedback they would like to give to the person they are rating by completing three open questions. Firstly, they were asked to list three things that they regard as the target manager's greatest strengths he/she contributes to the university, secondly then the three things they would like to see him/her change, stop, or start doing. Lastly, they could add any further constructive suggestions for improvement.

Pilot Test and Participant Briefing

A pilot test was undertaken to evaluate the appropriateness of the questions as well as the viability of the on-line system. A majority of the respondents agreed that the questions were suitable and appropriate but that the questionnaire was too long. To make the questionnaire more user friendly, the number of questions were reduced from 67 to 44. The findings showed that the system was efficient, user friendly and practical.

As the 360-degree feedback was new to the participants all participants were briefed on:

- The aim and objective of the process
- Understanding of the competencies and the rating scale
- Using the online questionnaire

The objective of the process was made explicit by clarifying that the process was implemented (a) to assist academic managers within the university in their development of leadership competence aligned to the new strategic direction of the university, (b) to measure the impact of the LEAD programme by means of a pre- and post-360-degree assessment, and (c) purely as a developmental process and *not* to use it in any way linked to selection, redeployment, promotion or remuneration. Ground rules governing the issues of confidentiality and anonymity were also communicated. It has been ascertained that all individual responses would be kept confidential and would be stored in an electronic database.

Participants

Although the aim of the project was to enhance the leadership capacity within the university as a whole, the target group for the leadership capacity building project included only academic managers within the university (Deans, assistant-deans, Heads of Departments (HODs) and section heads). This includes all academic managers in the 7 faculties as well as within the Higher Education Development and Support (HEDS) unit. A total of 112 staff members (N = 112) fall within these categories. Although 83 managers participated in the project by attending the LEAD programme, 88 managers participated in the 360-degree feedback process. Of these 88, only 73 (28 female and 45 males) participants complied with the requirement of a minimum of 3 raters (excluding themselves). Of these participants 9.6 % (7) held an executive management position (6 executive deans and 1 senior director), 15% (11) were assistant-deans; 60.3% (44) heads of departments (HODs) and 15.1% (11) were section heads. A total 694 raters participated which includes ratings by managers, peers, subordinates and the person him/herself. This is an average of 9.5 raters per participant.

Procedure

Each participant received an email from the external service provider with instructions on how to access the questionnaire and select their raters (i.e. people who have worked with them sufficiently to observe them accurately). They were asked to select people whose views represent a range of experiences with them, and whose views they would value as they identify their strengths and development areas. They could select as many as they like, but their raters should include the following people: the person's line manager; at least four subordinates, and at least four peers (i.e. others who work with them at the same level). Once the target manager have chosen his/her respondents and entered their email addresses on the system, the system automatically sent them an email explaining that they have been selected as raters and asking them to complete the questionnaire online. The feedback questionnaires for the target manager was completed anonymous. Overall, at least three people in total (excluding the participant him/herself) was required to generate a valid report. Each participant also completed a self-assessment along these behavioural descriptors.

The informed consent letter explained to all the participants (both the target manager and his/her raters) that the information in the completed questionnaires would be treated confidentially. Upon the completion of all assessments all ratings were collated and a feedback report was generated on the on-line platform for each target manager.

The Feedback Report and Process

If three or more raters from a specific category (e.g. Colleagues) have submitted feedback, the average score for raters in this category was displayed separately in the report, provided that this does not jeopardise the anonymity of any other rater (See Figure 1 for an example). In order to protect rater anonymity, some raters could not be displayed in their respective rater categories. Where possible, these raters were grouped together in a composite category. This category will be named "Combined". Unlike the rest of the raters, managers were not given the choice to waive or retain their anonymity. Therefore the target managers' line managers' responses are not anonymous and his/her

feedback is displayed in a separate category regardless of the number of managers who have submitted feedback. Line managers have been informed of this before submitting their feedback. The feedback report provided the following information:

- An introduction in which the four leadership competence clusters are defined;
- Suggestions to derive optimal benefit from the report;
- The number of raters from each subgroup that completed the questionnaire,
- Summary of the average scores by all raters for each of the four competence clusters;
- Scores in descending order per behavioural description in each of the leadership competence cluster, the first bar indicates this average score, with the two short black lines between the dotted line to the left and right of the average representing the range between the highest and lowest individual score on that item (See Figure 1 for an example)
- Relative strengths and development areas. These two tables show the eight items arranged from highest to lowest for which the manager have the highest and lowest average score of all of his/her raters.
- Self-versus-Others ratings. This table shows up to six items (plus possible ties) with the greatest difference between the managers self-score and that of his/her raters. These may be items which the target manager think are strengths or weaknesses but where others do not agree.
- Comparison with the overall university norm. This section compares the manager's ratings with the group's ratings - i.e. the average ratings for all managers in the university who participated in the 360-degree assessment process. This table shows up to six items (plus possible ties) with the greatest difference between the target manager's raters' scores, and the average of all scores for the group. These items are either the manager's particular strengths or development areas relative to the rest of the group.

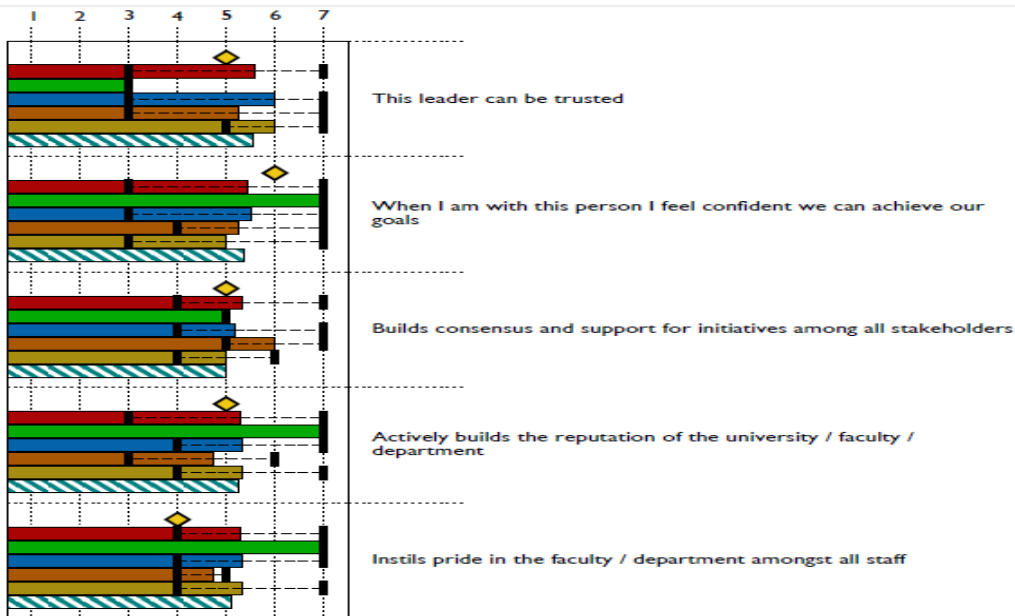
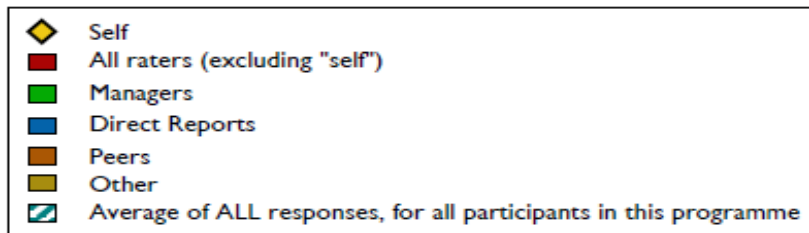

Figure 1: Bar chart illustrating the ratings per behavioural description that form part of the competency cluster 'Collaborative Change Management' in the feedback report

RESULTS

Managerial Self-Awareness

Congruence based self-awareness

In this study, managerial self-awareness was operationalized as congruence between self and direct reports' behavioural ratings of leadership behaviours. Participants' were rated on 44 statements identified as behavioural indicators of successful leadership within the university. Leadership behaviour ratings for the 73 academic managers in our sample were provided by 694 raters as described above. Each academic manager was rated by an average of 9.5 raters. Managerial self-awareness was calculated using Pearson's chi-square test of association, to discover if there is a relationship between two the categorical variables, namely Self and Other scores. As indicated in Table 1, males slightly overrated themselves on all four clusters and significantly overrated themselves in Cluster one: Collaborative change management. Women on the other hand slightly underrated themselves on three of the four clusters and significantly underrated themselves on Cluster three: Impactful relationships.

Table 1: Managerial self-awareness for each of the four leadership clusters				
Cluster One: Collaborative Change leadership	Mean		Standard Deviation (SD)	
	Female	Male	Female	Male
Observers	5.145 (N=251)	5.162 (N=370)	1.028	1.105
Self	4.931 (N=28)	5.260 (N=45)	1.024	.848
P-value	<i>0.2961</i> <i>P=0.148</i>	<i>0.5683***</i> <i>P=0.0716</i>		
Cluster Two: Strategy Translation & Innovation				
Observers	4.919	5.011	1.067	1.222
Self	4.885	5.108	1.002	.954
P-value	<i>0.873</i> <i>P=0.436</i>	<i>0.607</i> <i>P=0.696</i>		
Cluster Three: Impactful Relationships				
Observers	5.176	5.142	.962	1.078
Self	4.855	5.211	.943	.823
P-value	<i>0.949*</i> <i>P=0.047</i>	0.679 <i>P=0.660</i>		
Cluster Four: Disciplined Results Orientation				
Observers	5.284	5.156	.939	1.122
Self	5.1	5.276	.865	.822
P-value	0.321 <i>P=161</i>	0.4891 <i>P=755</i>		
*P<0.05				
**p<0.1				

Leadership Effectiveness

As can be seen in Table 2 the minimum and maximum average score per cluster ranged between 1 and 7 respectively. The average per cluster ranged between 4.978 and 5.208 which falls within the range of *effective* and *very effective*.

Cluster	Minimum	Maximum	N	Mean	SD	Median
Collaborative Change Leadership	1.73	7	694	5.153	1.059	5.18
Strategy Translation & Innovation	1	7	693	4.978	1.143	5
Impactful Relationship Management	1.53	7	694	5.147	5.147	5.13
Disciplined Results Orientation	1.27	7	694	5.208	5.208	5.225

DISCUSSION

According to Bracken, Timmreck, and Church (2001), the primary goal of 360-degree feedback is to motivate behaviour change. Whether the 360-degree feedback process and the subsequent LEAD programme succeeded in changing behaviour and building leadership capacity will only be determined once the 360-degree process is repeated after the completion of the LEAD programme. However, the findings of this preliminary study provided mixed findings and only partially confirmed the findings of previous studies (referred to in Detweiler-Bedell, Deitweiler-Bedell & Salovey, 2006; Herbst & Conradie, 2011) that managers tend to overestimate themselves. Although both males and females demonstrated low self-awareness (therefor exhibited low self-perception accuracy) the direction of the discrepancy in self-other ratings differed. Although not significant for all four clusters, males slightly overestimated themselves and this discrepancy was significant for Cluster one.

Females on the other hand, consistently underrated themselves on all four clusters and significantly underrated themselves on Cluster three. This is in line with earlier research studies (Taylor & Hood, 2011; Wohlers & London, 1989) that women have a greater tendency to underrate their skills or performance due to fact that they do not take credit for success and attribute it more to external sources than to ability. The finding by Taylor and Hood (2011, p. 640) that “women were clearly not undervaluing themselves when they self-rated any more than men” and confirmed by other studies (Van Velsor, et al., 1993; Sturm, Taylor, Atwater & Braddy, 2014) is therefore only partially supported. One possible explanation for this deflated self-ratings amongst females is that it might be a function of social-desirability or political factors (Braton, Dodd & Brown, 2011). That is, in an institution with a culture that discourages self-promotion amongst women (since women are still in minority in management position in this university), it would be reasonable to expect that female managers would be more likely to distort their self-ratings in a downward direction. As emphasized by Atwater and Yammarino (1997), in order to better understand the leadership effectiveness of self-raters, it is necessary to examine both the magnitude and the direction of the difference in self-other ratings. Further research is needed to explore the reasons for gender differences in self-awareness.

Furthermore, this study provided evidence that although the average score per cluster ranged between 1 and 7 respectively, the average rating for all managers combined fall within the range of effective. This is in line with the finding by Vinger and Cilliers (2006) that the level of transformational leadership amongst leaders in HEI in SA is relatively high. However, the large variation in scores indicate that there are those managers who are still perceived not to be effective in their leadership currently. These might be the managers that Ngcamu (2015) refers to when he states that HEI in South Africa are currently being led “by individuals who lack transformational capabilities” (p. 209) which directly impede the transformation agenda. As stated by Seale and Cross (2016) HEI in South Africa (SA) are facing major transformation challenges that require exceptional leadership, therefore as stated by Black (2015), institutions should reconsider how they develop their leadership talent and what constitute appropriate leadership behaviour.

REFERENCES

- Anderson, R. J. & Adams, W. A. (2016). *Mastering leadership: An integrated framework for breakthrough performance and extraordinary results*. New Jersey: New Wiley & Sons, Inc.
- Atwater, L. and Yammarino, F. (1992), Does self-other agreement on leadership perceptions moderate the validity of leadership and performance predictions? *Personnel Psychology*, 45(1), 141-164.
- Bendermacher, G. W. G., oude Egbrink, M. G. A., Wolfhagen, I. H. A. P. & Dolmans, D. H. J. M. (2016). Unravelling quality culture in higher education: a realist review. *Higher Education*, doi: 10.1007/s10734-015-9979-2.
- Blumenthal, B. & Haspeslagh, P. (1994). Toward a definition of corporate transformation. *Sloan Management Review*, Spring, 101–106.
- Bracken, D. W., Timmreck, C. W., & Church. A. H. (2001). *The Handbook of Multi-source Feedback: The Comprehensive Resource for Designing and Implementing MSF Processes*. San Francisco, CA: Jossey-Bass.
- Bratton, Virginia K., Nancy G. Dodd, and F. William Brown. (2011). The impact of emotional intelligence on accuracy of self-awareness and leadership performance. *Leadership & Organization Development Journal*, 32 (2), 127–149. doi:10.1108/01437731111112971.
- Chatman, J. A. & Kennedy, J. A. (2010). Psychological perspectives on leadership. In N. Nohria, & R. Khurana (Eds.), *Leadership: Advancing the discipline* (pp. 159-182). Cambridge, MA: Harvard Business School Publishing.
- Church, A.H. (1997), Managerial self-awareness in high-performing individuals in organizations, *Journal of Applied Psychology*, 82(2), 281-292.
- Damian, D. & Pitts, S. (2015). *Go Slow to Go Fast – planning to execution*. Morgan James Publishing, New York.
- Detweiler-Bedell, B., Detweiler-Bedell, J.B., & Salovey, P. (2006). Mood-congruent perceptions of success depend on self-other framing. *Cognition and Emotion*, 20(2), 196–216.
- Eid, J., Mearns, K., Larsson, G., Laberg, J., & Johnsen, B. (2012). Leadership, psychological capital and safety research: Conceptual issues and future research questions. *Safety Science*, 50(1), 55–61. <http://dx.doi.org/10.1016/j.ssci.2011.07.001>
- Fiedler, F. E. (1967). *A theory of leadership effectiveness*. McGraw-Hill, New York.
- Fleenor, J. W., Smither, J. W., Atwater, L. E., Braddy, P. W., & Sturm, R. E. (2010). Self–other rating agreement in leadership: A review. *Leadership Quarterly*, 21(6), 1005–1034.
- Gupta, A.K. & Govindarajan, V. (2002), Cultivating global mindset, *Academy of Management Executive*, 16(1), 116-26.
- Herbst, T.H.H., & Conradie, P.D.P. (2011). Leadership effectiveness in Higher Education: Managerial self-perceptions versus perceptions of others. *SA Journal of Industrial Psychology/SA Tydskrif vir Bedryfsielkunde*, 37(1), DOI: 10.4102/sajip.v37i1.867.
- Hernandez, W., Luthanena, A., Ramsela, D. & Osatukea, K. (2015). The mediating relationship of self-awareness on supervisor burnout and workgroup Civility & Psychological Safety: A multilevel path analysis. *Burnout Research*, 2, 36–49. <http://dx.doi.org/10.1016/j.burn.2015.02.002>
- Hogan, J. & Hollard, B (2003). Using theory to evaluate personality and job-performance relations: A socio-analytical perspective. *Journal of Applied Psychology*, 88, 100-112.
- Jokinen, T. (2005). Global leadership competencies: a review and discussion. *Journal of European Industrial Training*, 29(3), 199-216.

- Kets de Vries, M. F. R. & Korotov, K. (2010). *Transformational leadership development programmes: Creating long-term sustainable change*. INSEAD Working paper, 2010/72/EFE/IGLC
- Kets de Vries, M. F. R., Vrignaud, P., Florent-Treacy, F. & Korotov, K. (2007). INSEAD Global Leadership Centre – 360-degree feedback instruments: An Overview, Faculty & Research Working Paper, Fontainebleau.
- MacKie, D. (2015). Who sees change after leadership coaching? An analysis of impact by rater level and self-other alignment on multi-source feedback. *International Coaching Psychology Review*, 10(2), 118-130.
- Moshavi, D., Brown, F. W., & Dodd, N. G. (2003). Leader self-awareness and its relationship to subordinate attitudes and performance. *Leadership and Organizational Development Journal*, 24(7), 407-418.
- Ngcamu, B. S. (2015). Leadership and transformation in a South African university. *Problems and Perspectives in Management*. 13(1), 208-216.
- Oh, I. S. & Berry, C. M. (2009). The five-factor model of personality and managerial performance: Validity gains through the use of 360-degree performance ratings. *Journal of Applied Psychology*, 94, 1498-1513.
- Seale, O. & Cross, M. (2016) Leading and managing in complexity: the case of South African deans, *Studies in Higher Education*, 41:8, 1514-1532, DOI:10.1080/03075079.2014.988705
- Sosik, J. (2001), Self-other agreement on charismatic leadership: relationships with work attitudes and managerial performance, *Group & Organization Management*, 26 (4), 484-511.
- Sturm, R. E., Taylor, S. N., twater, L. E. and Braddy, P. W. (2014). Leader self-awareness: An examination and implications of women's under-prediction. *Journal of Organizational Behavior*, 35, 657-677. DOI: 10.1002/job.1915
- Tang, K. Y., Dai, G., & De Meuse, K. P. (2013). Assessing leadership derailment factors in 360° feedback: Differences across position levels and self-other agreement. *Leadership & Organization Development Journal*, 34, 326-343.
- Taylor, S. N. (2010). Redefining leader self-awareness by integrating the second component of self-awareness. *Journal of Leadership Studies*, 3(4), 57-68.
- Taylor, S. N., & Hood, J. N. (2011). It may not be what you think: Gender differences in predicting emotional and social competence. *Human Relations*, 64, 627-652.
- Taylor, S. N., Wang, M., & Zhan, Y. (2012). Going beyond self-other rating comparison to measure leader self-awareness. *Journal of Leadership Studies*, 6(2), 6-31. <http://dx.doi.org/10.1002/jls.21235>.
- Tiuraniemi, J. (2008). Leader self-awareness and its relationship to subordinate assessment of organizational atmosphere in the social welfare sector. *Administration in Social Work*, 32(4), 23-38. <http://dx.doi.org/10.1080/03643100802293824>.
- Van Velsor, E., Taylor, S. & Leslie, J. (1993). An examination of the relationships among self-perception accuracy, self-awareness, gender and leader effectiveness, *Human Resource Management*, 32(2/3), 249-264.
- Vinger, G & Cilliers, F. (2006). Effective transformational leadership behaviours for managing change. *SA Journal of Human Resource Management*, 2006, 4 (2), 1-9
- Wohlers, A. J., & London, M. (1989). Ratings of managerial characteristics: Evaluation difficulty, co-worker agreement, and self-awareness. *Personnel Psychology*, 42, 235-261.
- Yammarino, F. J., & Atwater, L. E. (1993). Understanding self-perception accuracy: Implications for human resource management. *Human Resource Management*, 32, 231-247.

SOME SINS IN THE NEGOTIATIONS IN TIMES OF INDUSTRY 4.0: SOCCER AND BREXIT

**José G. Hernández R., Gilberto J. Hernández G. & María J. García G.
Minimax Consultores C. A., Venezuela**

ABSTRACT

This paper establishes the relationship between two fields of knowledge and business activity: Industry 4.0 and the negotiations. Industry 4.0 is a consequence of a new world that is arising, but that simultaneously is created from this concept, where dominate the sensors, measurements, the systems and the management of a large amount of data. On the other hand, negotiations exist since the man needed possessions and goods that were not directly at his disposal, but which he could acquire, in exchange for other goods or other possessions. Consequently the negotiations have been dominated by humans and the direct exchange between them. However, these two aspects, apparently dissimilar, must coexist with their successes and their mistakes, in the current world. From all the expressed the objective of this work arises, which can be stated: Analyze certain characteristics of a negotiation process in the Industry 4.0 environment and some of the errors that can be committed.

Keywords: Industry 4.0, Negotiations, Brexit, Soccer, Errors in the negotiation process.

INTRODUCTION

To understand the concept of Industry 4.0, perhaps it is necessary to know that they are the Cyber-Physical Systems (CPS), which define Lee, Bagheri & Kao (2015), as the technological transformations that allow to the networked systems to manage physical assets through computational capabilities. It is necessary to mention the CPS because the transformation toward the fourth generation of the industrial revolution (Industry 4.0), as pointed out Lee, Kao & Yang (2014), it is based on the services and innovation of the CPS.

On the other hand, Brettel et al. (2014), commented that the first three industrial revolutions were based on technological innovation: the introduction of water and steam as mechanical energy, at the end of the XVIIIth century; the division of labor, to beginnings of the XXth century and as third, at the end of the XXth century, the introduction of the automation of the processes of manufacture, through the programmable logic controllers (PLC). However, according to what point Rüßmann et al. (2015) and Schmidt et al. (2015), it is important to clarify that the second revolution, it is preferable to associate with the industrial use of electricity, which allowed and facilitated the mass production, rather than to the division of labor in itself.

The authors previously mentioned (Brettel et al. (2014), point out that the next industrial revolution is driven via the Internet, to facilitate communication between humans and machines making use of the CPS. In addition, they identified four areas of research linked with the topics associated with Industry 4.0, these areas are: individualization, virtualization (virtual version), hybridization and self-optimization (autonomous systems).

In order for these autonomic systems can to function with some utility, a large number of sensors are needed, which are capable of collecting a lot of data (Schlechtendahl et al., 2015), which should be converted into useful information, for this reason the Big Data, are usually associated with Industry 4.0 and its management means great improvements to the productive systems (Rüßmann et al., 2015).

Based on these latest comments, it can be deduced that the combination of the strengths of industrial manufacturing optimized with the use of cutting-edge Internet technologies constitute the core of Industry 4.0 (Schmidt et al., 2015).

Specifying something more, it is possible to say that the term Industry 4.0, which was coined by German mechanical engineering associations (Kolberg & Zühlke, 2015), corresponds to the greater integration of the Information and Communication Technologies (ICT) with the productive processes. In addition, these authors (Kolberg & Zühlke, 2015) emphasize, that between many other aspects it is possible to affirm, that Industry 4.0, helps to obtain: operators, products, machines and plans more intelligent.

On the other hand Rübmann et al. (2015) present nine pillars associated with Industry 4.0: Autonomous Robots, Simulation, Horizontal and Vertical Systems Integration, The Industrial Internet of Things (IoT), Cloud Computing, Cybersecurity, Additive Manufacturing, Augmented reality and Big Data and Analytics.

While Brettel et al. (2014), present a broader picture, already they focus on three large fields and around them point to a number of areas and activities related to the Industry 4.0 environment, these three large fields and their related areas are: 1. Individualization of production, which has associated: Mass customization, Modularization, Distributed Control, Auto-optimization, Flexible Manufacturing Systems (FMS) & Reconfigurable Manufacturing System (RMS) (FMS & RMS), Rapid Manufacturing and Cloud computing; 2. Horizontal integration and collaborative networks, to which they are associated: Collaborative Networks, Distributed Manufacturing, Supply Chains (SC) flexibility, SC visibility and IoT and Services and 3. End-to-end digital integration, which has associated with it: Virtualization of the production chain, Individualized traced data, Real-time operating systems, Simulation and modeling of products and processes, Simultaneous planning of products and production processes and Value added services. And another idea associated with Industry 4.0 is that all participants are connected and can exchange data and information (Schlechtendahl et al., 2015), although for this to be a reality it is necessary a good coordination of the different CPS.

Although there are many aspects to note about Industry 4.0, for the interest of this work, it can close these comments stressing that it is a concept, which can improve and facilitate the lives of human beings; their strengths are in the systems and automation capabilities.

This contrasts with the other aspect to be covered in this work, the negotiations, which, although they can be carried out between individuals who are distant from each other, the normal thing is that they are carried out directly and with a high interaction between humans. Even one of the aspects to which special attention is given in the negotiation processes, as indicated by Gelfand et al. (2013) it is to the negotiation teams. And these authors, stand out, which typically negotiations involve two teams or two or more persons negotiating around the table; understand table of negotiations.

On the other hand stand out Gelfand et al. (2015) that negotiations require creativity, to find or to invent new options that satisfy the tangible and intangible interests of all the involved parts.

Also there is a series of terms that must take in account when studying the negotiations: process, strategies, culture, exchange of information, adaptation of the strategy (Gunia, Brett & Gelfand, 2016), interact, cooperation, decision making, power (Kopelman et al., 2016). And it can see that all these terms are related to the interaction and communication between humans. Hence, it could be said that the negotiations concern people.

Additionally in the work of Wu et al. (2013) by giving their definition of a Service Level Agreement (SLA), say it is a legal contract between suppliers and consumers that defines the Quality of Service (QoS), which must be achieved through a negotiation process and they add that this cloud negotiation process is essential, because the parties involved are separate entities with different objectives and needs of QoS. And continue to, commenting that through negotiation, the participants in the market of the cloud have the opportunity to improve the return on their investment. These comments of Wu et al. (2013) make reflect on two aspects, the first that in a negotiation process always seeks some kind of benefit, which is not necessarily monetary and second, that now in the world of the digital era and the massive management of data in the cloud, the negotiation processes are still valid.

If the two approaches made so far: the Industry 4.0 and the negotiations, are added, that in one as the other one can make mistakes, arises the objective of this work: Analyze certain characteristics of a negotiation process in the Industry 4.0 environment and some of the errors that can be committed.

From this general objective arise the following specific objectives:

- Introduce the Industry 4.0 concept.
- It comments on the need for communication in the world of negotiations.
- To show, through brief hypothetical and simple examples, partial visions of the real world, some of the errors that can be committed in the process of negotiation in the world of Industry 4.0.

To comply with both the overall objective, as with the specific objectives, it will follow the Integrated-Adaptable Methodology for the development of Decision Support System (IAMDSS, in Spanish, Metodología Integradora-Adaptable para desarrollar Sistemas de Apoyo a las Decisiones [MIASAD]) (García, Hernández & Hernández, 2014; Hernández, García & Hernández, 2014), which, among its characteristics stands out not to raise hypotheses, but to follow a series of steps. And for its flexibility and adaptability to different types of research (García, Hernández & Hernández, 2014; Hernández, García & Hernández, 2016; Pérez et al., 2015; Schwarz et al., 2016), it can be used, from it, only the steps that are considered necessary. From there, similar to the one realized in other works (Hernández, García & Hernández, 2016; Pérez et al., 2015), only the following steps will be used:

- a) Define the problem that, as indicated in the objectives, is analyze certain characteristics of a negotiation process in the Industry 4.0 environment and some of the errors that can be committed;
- b) Develop a first prototype, which has among its main functions to provide a complete overview of what will be the investigation and the first thing to do is to identify the users of the final product, that is the main readers of this article, that will be all those interested in the new concept Industry 4.0, that will be all those interested in knowing and studying the processes of negotiation, especially under the age of the Internet. Also, with this first prototype, it seeks to establish the structure of the article, which, in addition to this introduction, where it has already introduced the concept of Industry 4.0 and made some comments on the processes of negotiation, will consist of a central chapter, which will present a couple of examples of negotiation processes, which have happened in the current era, the of Industry 4.0, but more than presenting the negotiation process will focus the interest in some of the errors that could be committed;
- c) Obtain data, mainly on Industry 4.0 and the processes of negotiation;
- d) Define alternatives, which will be all those ways that serve to illustrate the processes of negotiation in the world of Industry 4.0 and that at the same time allow to detect some possible errors that can be committed during these processes;
- e) Evaluate alternatives. According to the ability of each one of the different alternatives to illustrate the negotiating processes in Industry 4.0 and of some of the errors that can be made;
- f) Select the best alternative, according to the secondary, tacit or explicit, objectives that have been contemplated;
- g) Implement the best alternative, although it can not speak of implementation itself, it tries, through hypothetical cases, even if taken from the real world, to illustrate, rather than negotiation processes, some of the possible errors that can be made and
- h) Establish controls, mechanisms, which allow to recognize if the solution obtained, remains valid in the course of time.

In this case it is important to clarify that while the alternative is being selected, the cases are being selected that will serve as an illustration of possible failures in the negotiation process. Although this selection it cannot be justified in a quantitative manner and not even in a qualitative manner.

With regard to limitations and scope, no work will be done in the field, but will illustrate some possible errors in the processes of negotiation, in an environment of Industry 4.0, with two simple and somewhat hypothetical examples, to guarantee a greater generality of the results obtained.

THE BREXIT AND SOCCER. TWO EXAMPLES OF NEGOTIATION PROCESSES, IN THE INDUSTRY 4.0 ERA

Instead of taking two cases from the industrial world, where Industry 4.0 is easier to recognize, it has been decided to use two examples away from the manufacturing industry and without there being any special reason that requires this selection have been chosen: the decision on the Brexit and the contract, by an important soccer team to a recognized player, whose career was on the rise.

The Brexit, as is well known, by a large number of the population of the world, it is the process by which the United Kingdom (UK) decides to withdraw from the European Union (EU). And as any process of separation or rupture, will obviously have consequences, positive and negative for both parties. Although it should be clarified that this work will try to stay away from the discussion of these consequences, in the sense of taking sides if the decision was a good or bad decision.

Although there are many works that comment on the consequences of Brexit (Dhingra et al., 2016; Ebell & Warren, 2016; Springford & Whyte, 2014; Vickers, 2017; Wadsworth et al., 2016), in this investigation, an analysis of these consequences will not be made, nor will a detailed analysis of the previous process be made as it could be found in Vasilopoulou (2016), only focus will be on one aspect of the referendum that led the UK to start the process of separation. This aspect is the handling of information by voters, an issue on which Vasilopoulou (2016) makes a series of comments.

On the other hand, it is not new to affirm that soccer is an industry, which moves large amounts of capital, so on many occasions it should see the world of football as a business (Di Minin et al., 2014; Hernández, García & Hernández, 2014; Jewell, Simmons & Szymanski, 2014; Morrow & Howieson, 2014). Although Kuper & Szymanski (2014) affirm that it is the worst business in the world.

From there, that the process of buying and selling of players, are, at least, interesting. In this case the example will be presented as hypothetical, but it will be based on the procurement by a team of great prestige, which from now on is referred to as the team R (ER), of a player, who was expected to become one of the stars of the team. To maintain his anonymity to this player from now on will be identified as player J (JJ).

And just like the previous case, only the use of information will be handled, in this case by the JJ.

At the beginning of the work it was stated that Industry 4.0, among other elements was based on the handling of Big Data and the possibility of having sensors that could send information in real time. In the two examples being discussed, the lack of information and the ability to manage all of the information that was necessary to have, are a critical aspect, to that the negotiation was carried out in favorable terms for both parties.

And it is important to note that this is not asymmetric information, since neither those who did not support the Brexit, nor the owners of the ER sought to obtain some additional benefit, for the lack of information of the voters in a case or of JJ in the other case.

To facilitate and make the analysis more concrete, in table 1, presents some aspects that characterize this pair of negotiation examples in the times of Industry 4.0. At the same time they will point out some possible errors. And there is some element, which could be taken into account to minimize the effect of the respective error, analyzing it, especially, from the point of view of the Industry 4.0 environment.

Table 1: Some characteristics of the two negotiations to be analyzed.

Aspect to consider	Case	
	Brexit	JJ - ER
Who takes the decision?	Million persons of the UK.	A player (JJ) and his representative.
Who is affected by the decision?	Practically all over the world, but mainly the US and the UK.	To a recognized team of soccer (ER) and one of its players (JJ).
How is the decision taken?	Through a referendum.	By accepting, by both parties (ER and JJ) all clauses of a contract.
Impact time of decision	For a very long term.	In the time of duration of the contract, but it can affect the useful life of JJ.
When does the decision become effective?	In several stages and in short, medium and long term.	Almost immediately, when signing the contract.
In what moment are the consequences seen?	Someone immediately, but the majority a medium and long term.	From the beginning of the season. It can be said, immediately.
Error 1: Worse results in the short term.	Taken the decision, the market sees both parts (UK and EU) less reliable. This immediately devalues both currencies.	Before beginning the season ER makes new hires, even for the position of JJ. This can minimize the minutes of play of JJ.
Elements to minimize the impact of the error 1.	Taken the decision, it is few what it is possible to do, the devaluation in the short term, it was imminent. Before taking the decision, the electors (UK) could have estimated it.	JJ could demand a clause, that in the short term they would not hire other players of his position. If ER considered that it was not possible, given the need for substitutes, JJ could have demanded other compensations.
Limitations in the Industry 4.0 environment. For error 1.	Although the information could be available, it was almost impossible to make it understood by all voters, given their different capacities to assimilate this information, which in a way is specialized.	A priori JJ and his attorney, could and should have obtained information from available players that might be of interest to ER. The biggest challenge was to know the plans of ER.
Summary in the Environment of Industry 4.0. Of the error 1.	If the society was behaving as a company of Industry 4.0, it would be necessary to have prepared better the population and to have offered better information.	If JJ was working as a company of Industry 4.0, he could have invested time and money to know better the plans of ER. And in any case to do a better handling of the information.
Error 2: Worse results in the medium term.	The EU, to avoid the exodus of other countries hardens the conditions of exit of the UK. This can create tensions in the EU, but especially for the UK it means major payments and compensations of the awaited ones.	The performance of the ER begins to be low and it is decided to change his trainer. The change of coach is fatal for JJ, since he is not a man of maximum confidence for the new coach. This is minus minutes for JJ.
Elements to minimize the impact of the error 2.	Just as the error 1, it had to avoid the error before committing it, which is to say before the referendum. Again an estimate in advance could have been the solution.	The low performance of a squad, which entails to the removal of a coach, in general depends on a few players, "the stars". Just as the error 1, JJ should have obtained major information; in this case, of his future partners.
Limitations in the Industry 4.0 environment. For error 2.	The situation becomes very similar to what was stated in error 1.	Similar to what was commented on in error 1. But also here JJ, need sensors that were able to measure the situation to forecast the future.
Summary in the Environment of Industry 4.0. Of the error 2.	What was said for error 1 is still valid.	Again JJ should have invested time and money. Now to acquire a system of data collection, that allows him to know better his future surroundings.
Error 3: Worse results in the long term.	Consequence of not completely friendly exit, the negotiations to future harden. It diminishes the commercial trade between the EU and the UK.	Having fewer minutes of play, the attitude and the conditions of JJ are affected and affect their performance and the confidence of the coach.

Table 1: Some characteristics of the two negotiations to be analyzed. (Continuation)		
Aspect to consider	Brexit	JJ - ER
Elements to minimize the impact of the error 3.	The error must be corrected before committing. First time of correction, not to carry out the referendum, Second, inform the population well but not to lose the referendum and third time, maintain a good climate during the exit process, under a win-win business approach.	JJ has two basic decisions: gain the confidence of the trainer or leave the ER as soon as possible, before its market value declines. In the first case should consider the style of the coach to adapt at the same. In the second case must study the market and see potential teams who are interested in him and which he can fit.
Limitations in the Industry 4.0 environment. For error 3.	Here the greatest limitations, is simultaneously an opportunity, it is necessary to create a system that allows to obtain information, to know new needs on new markets.	Here the principal limitation comes from the conduct of the persons. But on the other hand there is an element of Industry 4.0, of great utility and is the Value added services, which must be applied in either of the two options for JJ.
Summary in the Environment of Industry 4.0. Of the error 3.	As this is a long term situation, it must work to achieve the Industry 4.0 environment. In this sense it must try to incorporate as many possible elements of this environment.	Although in this case the long term is not so long. JJ must try to incorporate the biggest quantity of possible elements of the environment of Industry 4.0. Mention has already been made of the value added service and better management of the information. In addition he can obtain information with the use of Internet.

From the Table 1 there arose a series of elements of the environment of Industry 4.0, some from indirect form and others in explicit form, of them can be recognized: Cloud Computing, Systems Integration, Big Data and Analytics, Internet of Things and Services, End-to-end integration, Individualized traced data, Real-time operating systems and Value added services, to which there could be added other elements keys as the availability of sensors, the possibility of doing measurements and of realizing simulations, work in modular form, Mass customization and the auto optimization.

However, the element of the environment of Industry 4.0, which dominates the entire table, is the good management of the information.

It is the mismanagement of information the great sin that is committed when trying to negotiate in the times of Industry 4.0. Sometimes this mismanagement of information comes from the absence of it, which in turn may be a consequence of not having the platforms to acquire it. Secondly, the mismanagement of information is caused by not being able to extract it from the appropriate sources, which in this case is a consequence of not having the adequate sensors, including here the individuals prepared for these tasks. In the third case, the information is reached, but it is not prepared to take advantage of it and here may be a problem of training of the responsible personnel or the acquisition of equipment, which are able to perform the proper management of the same.

In any case any failure in the availability, acquisition or handling of the information will result in mismanagement of the information and therefore high chances of committing serious sins during the negotiation process where this information is necessary.

With these short comments and the brief analysis of the two cases exposed: Brexit and Soccer, it can have a clear idea of the sins that can be committed in the negotiations in the times of Industry 4.0, so that next will be presented to some conclusions and future lines of research.

CONCLUSIONS AND FUTURE RESEARCH

Without going into depth in any of them, in this work were presented a pair of negotiation processes: the Brexit, of great relevance and worldwide impact, and although of less impact, however affects in the world of sports one of the most renowned soccer teams, who was identified as ER and one of its players, named as JJ.

Part of these negotiation processes were analyzed from the perspective of the Industry 4.0 environment and emphasizing possible errors that could be made in each of these negotiations.

Through a very concise analysis, carried out with very few details were presented in each of the cases three types of possible errors, in the short, medium and long term and it was evidenced that the main source of the errors was given by the information handling. This allowed to detect the largest sin that can be committed in a negotiation process in the times of Industry 4.0. It is fulfilling in this way the general objective of this work.

In addition, with this analysis it finished drawing an overview of what the concept of Industry 4.0 and it was possible to visualize how important communications are in any negotiation process. In order to achieve the specific objectives that had been established. Although very succinct and lacking in details, the analysis performed, allows to present some recommendations and propose certain lines of future research. First of all, it is proposed to conduct research to analyze the characteristics that must have a negotiating team, in order to have a proper performance in the Industry 4.0 environment.

On the other hand, organizations are forced to investigate what are the best ways, according to their resources, they have to find, acquire and process relevant information. This applies not only to participate in processes of negotiation, but for its overall performance. Although in this work it was determined that the management of the information can be the cause of the greatest sins, in a negotiating process in an environment of Industry 4.0, it is recommended to deepen the investigation on this aspect.

ACKNOWLEDGMENTS

This investigation would not have been possible without the support given by: Minimax Consultores, C.A., through its Research Management.

REFERENCES

- Brettel, M., Friederichsen, N., Keller, M. & Rosenberg, M. (2014). How virtualization, decentralization and network building change the manufacturing landscape: An Industry 4.0 Perspective. *International Journal of Mechanical, Industrial Science and Engineering*, 8(1), 37-44.
- Dhingra, S., Ottaviano, G. I., Sampson, T. & Reenen, J. V. (2016). *The consequences of Brexit for UK trade and living standards*. Working paper from Centre for Economic Performance (CEP) at the London School of Economics, London, UK, 1-12.
- Di Minin, A., Frattini, F., Bianchi, M., Bortoluzzi, G. & Piccaluga, A. (2014). Udinese Calcio soccer club as a talents factory: Strategic agility, diverging objectives, and resource constraints. *European Management Journal*, 32(2), 319-336.
- Ebell, M. & Warren, J. (2016). The long-term economic impact of leaving the EU. *National Institute Economic Review*, 236(1), 121-138.
- García G., M. J., Hernández G., G. J. & Hernández R., J. G. (2014). A Methodology of The Decision Support Systems applied to other projects of Investigation, In Mehdi K. (Ed.), *Encyclopedia of Information Science and Technology*, Third Edition: Hershey, PA: IGI Global, V3, 1978-1990.
- Gelfand, M. J., Brett, J., Gunia, B. C., Imai, L., Huang, T. J. & Hsu, B. F. (2013). Toward a culture-by-context perspective on negotiation: Negotiating teams in the United States and Taiwan. *Journal of Applied Psychology*, 98(3), 504-513.
- Gelfand, M. J., Severance, L., Lee, T., Bruss, C. B., Lun, J., Abdel-Latif, A., Al-Moghazy, A. A. & Ahmed, S. M. (2015). Culture and getting to yes: The linguistic signature of creative agreements in the United States and Egypt. *Journal of Organizational Behavior*, 36(7), 967-989.
- Gunia, B. C., Brett, J. M. & Gelfand, M. J. (2016). The science of culture and negotiation. *Current Opinion in Psychology*, 8, 78-83.
- Hernández G., J. J., García G., M. J. & Hernández R., J. G. (2014). *Fantasy Leagues and Decision making under uncertainty. An approach*. In Proceedings of 15th Applied Stochastic Models and Data Analysis (ASMDA 2013), Mataros, Spain, 451-463.
- Hernández R., J. G., García G., M. J. & Hernández G., G. J. (2016). Enterprise diagnosis and the Environmental manager of LoMoBaP. *Journal of Global Business and Technology*, 12(1), 60-76.
- Jewell, R. T., Simmons, R. & Szymanski, S. (2014). Bad for business? The effects of hooliganism on English professional football clubs. *Journal of Sports Economics*, 15(5), 429-450.
- Kolberg, D. & Zühlke, D. (2015). Lean automation enabled by industry 4.0 technologies. *IFAC-PapersOnLine*, 48(3), 1870-1875.
- Kopelman, S., Hardin, A. E., Myers, C. G. & Tost, L. P. (2016). Cooperation in multicultural negotiations: How the cultures of people with low and high power interact. *Journal of Applied Psychology*, 101(5), 721-730.
- Kuper, S. & Szymanski, S. (2014). *Soccernomics: Why England loses, why Spain, Germany, and Brazil win, and why the US, Japan, Australian and even Iraq are destined to become the kings of the world's most popular sport*. Nation Books: NY, USA.
- Lee, J., Bagheri, B. & Kao, H. A. (2015). A cyber-physical systems architecture for industry 4.0-based manufacturing systems. *Manufacturing Letters*, 3, 18-23.

- Lee, J., Kao, H. A. & Yang, S. (2014). Service innovation and smart analytics for industry 4.0 and big data environment. *Procedia CIRP*, 16, 3-8.
- Morrow, S. & Howieson, B. (2014). The new business of football: a study of current and aspirant football club managers. *Journal of Sport Management*, 28(5), 515-528.
- Pérez, D. E., Hernández, J. G., García, M. J. & Hernández, G. J. (2015). *Hurwicz Method modified and The Amplitude Model (TAM)*. In Seventeenth annual International Conference Global Business And Technology Association, Reading Book: USA, 559-566.
- Rußmann, M., Lorenz, M., Gerbert, P., Waldner, M., Justus, J., Engel, P. & Harnisch, M. (2015). Industry 4.0: The future of productivity and growth in manufacturing industries. *Boston Consulting Group*, 1-13.
- Schlechtendahl, J., Keinert, M., Kretschmer, F., Lechler, A. & Verl, A. (2015). Making existing production systems Industry 4.0-ready. *Production Engineering*, 9(1), 143-148.
- Schmidt, R., Möhring, M., Härting, R. C., Reichstein, C., Neumaier, P. & Jozinović, P. (2015). *Industry 4.0-potentials for creating smart products: empirical research results*. In International Conference on Business Information Systems. Springer International Publishing, 16-27.
- Schwarz I., L. M., Schwarz I., T. M., García G., M. J., Hernández G., G. J. & Hernández R., J. G. (2016). *Social Impact of Restrictions on Inventory Management*. In Proceedings ICIL2016, AGH University of Science and Technology in Krakow, Krakow, Poland, 272-282.
- Springford, J. & Whyte, P. (2014). *The consequences of Brexit for the City of London*. Working paper from Centre for European Reform, London, UK, 1-10.
- Vasilopoulou, S. (2016). UK Euroscepticism and the Brexit Referendum. *The Political Quarterly*, 87(2), 219-227.
- Vickers, J. (2017). Consequences of Brexit for competition law and policy. *Oxford Review of Economic Policy*, 33(suppl_1), S70-S78.
- Wadsworth, J., Dhingra, S., Ottaviano, G. & Van Reenen, J. (2016). Brexit and the Impact of Immigration on the UK. *Centre for Economic Performance. LSE*, 34-53.
- Wu, L., Garg, S. K., Buyya, R., Chen, C. & Versteeg, S. (2013). *Automated SLA negotiation framework for cloud computing*. In Cluster, Cloud and Grid Computing (CCGrid), 2013 13th IEEE/ACM International Symposium on, 235-244.

A GRAPH MODEL FOR LARGE AND HETEROGENEOUS DATABASE ARCHITECTURES

D. Frank Hsu and Xiaojie Lan
Fordham University, New York, USA

ABSTRACT

Rapid growth of large and heterogeneous relational datasets has given rise to the proliferation of new models and platforms for data storage and analytics. Many of these models use graphical structure to store and analyze data. However, companies are faced with the fundamental issue of managing these large and multiplatform databases in order to meet the software architecture need and business objective. In this paper, we present a graph model for storing and analyzing large and diverse datasets. The graph model entails three layers: Graph layer, Database layer, and Interoperability layer. This approach enables us to better understand, analyze, and display data using graph theory as well as to make better-informed decisions about the goals and objectives of acquired data. We also include a system example with three diverse use cases to illustrate the Graph layer of the graph model. Our current study marks the beginning of an ongoing investigation on the design, implementation, and analytics of large and complicated database architecture using graph theory and graph algorithms.

Keyword: Directed Acyclic Graph (DAG), Graph Algorithms, Graph Model, Graphical Database, Strongly Connected Components.

INTRODUCTION

Companies are faced with the rapid growth of large and heterogeneous datasets in traditional and non-traditional transaction processing cases, high velocity use cases, and cases where a database must be maintained, updated, and analyzed with queries and programming API's. Many of these use cases lead, by either technical requirements or business necessity, to a variety of new models and platforms for data storage and analytics. Although these use cases vary in platform implementation, many of them harness various graph properties and utilize graph structure and algorithms techniques to design, update, query, and analyze the database. McColl et al [13] gave a performance comparison of twelve open source graph databases with respect to four graph properties or algorithms: Single Shortest Paths (SSSP), Shiloach-Vishkin connected components algorithm [20], PageRank [3] in the vertex-parallel Bulk Synchronous Parallel (BSP) style, and the performance of a set of edge insertions and deletions across graphs containing 1K, 32K, 1M, and 16M nodes with 8K, 256K, 8M, and 256M undirected edges.

Although the study in [13] of the twelve open source graph databases showed that three graph databases (Boost [5], MTGL [14], and STINGER [22]) consistently rank among the highest performance, other graph databases perform well in some individual test at certain scale. For example, SQLite [21], a traditional relational database, performs well in the SSSP and PageRank test at the scale of 32K nodes and 256K edges using the graph package. Network X [16], the only Python package in the set, outperforms other Java-based packages in all but the PageRank test. Another example is Giraph [7] which performs highest among Java implementation in all tests except the SSSP. This demonstrates a variation among performance of the graph databases with respect to different tests at various graph size. It is also suggested that "graph database must become more graph aware in the design of data structure and query language" [13].

In this paper, we propose a graph model for building a large and heterogeneous database architecture. It is based on graphs and graph theory which has received extensive study in the past few decades [2]. The graph model

consists of three layers: (a) Graph layer, (b) Database layer, and (c) Interoperability layer. It harnesses graph structure and graph theory in the design, update, query, analysis, and visualization of a database. In particular, we use the theory of directed graphs, called digraphs, with data item as a set of nodes and a set of edges relating two nodes in the node set [2]. Graph theory in general and digraphs in particular have been applied to a variety of domains and use cases in science, technology, society, and engineering (see [2, 4]). On the simple and intuition side, a network (traffic network, logistics networks, or social network) is a graph with certain prescribed properties. If direction of each edge matters, then it is a digraph. On the complicated side, graphs or digraphs are used to model more complex relations such as the Internet (interconnection of networks), IoT (Internet of Things), or Protein-Protein interconnection networks. More recently, a special kind of digraph, called de Bruijn digraph, was used to study genome assembly in biomedical science and technology [11]. For definition and properties of digraphs and other graph algorithms and applications, the readers are referred to the book [2].

Section 2 will describe the graph model and discuss the graph structure and algorithm with respect to the database architecture. In section 3, we include a system example of a graph algorithm, called GA_1 , to illustrate the graph layer (Layer (a)) of the graph model with three diverse use cases. Section 4 concludes the paper with a summary and suggestion for further work.

THE GRAPH MODEL

Our graph model is digraph-based and has three layers: **(a) Graph layer**, **(b) Database layer**, and **(c) Interoperability layer** (see Figure 1). **Layer (a)** starts with an initial digraph (a)(1) where each node a consists of a data item or a record. Node a is adjacent to node b if a is “related” to b (written as a directed edge: $a \rightarrow b$) [2]. This digraph is constructed using user acquired datasets from business transaction or other relational phenomena. The digraph (a)(1) is a graphical representation of the acquired datasets in which relation between data items is important. However, this initial digraph has to be updated (simplified or revised) in order to get ready for implementation as a database. For example, the updated digraph (see (a)(2)) can be a DAG (directed acyclic graph) where there is no directed cycle. In such a case, the updated digraph in (a)(2) is obtained by identifying strongly connected components (SCC) and converting each SCC into a supernode.

The **Database Layer (Layer (b))** is the design and implementation of enterprise database corresponding to an updated digraph in Layer (a)(2) using data structure such as adjacent lists, heap structure, linked lists, as well as stacks and queues. The **Interoperability Layer ((c))** is a graphical database management system (GDBMS). It has three sublayers: System Analysis sublayer ((c)(1)), Analytics sublayer ((c)(2)), and Visualization sublayer ((c)(3)).

For each of the layers (a) and (b) in Figure 1, we also include Graph parameters and Data structures respectively. Graph parameters include structure and connectivity of the graph as well as graph latency such as average path length and diameter. Data structures include adjacency lists, stacks and queues, and other structures such as trees and heaps. Layer (c) consists of the acquisition, analytics, and visualization of data or information from the database architecture using query languages and graph algorithms. This would provide services and solutions to the problems raised by application domain which originated the complex and heterogeneous datasets.

The System Analysis sublayer ((c)(1)) in Figure 1, in the context of a software system architecture pipeline, contains a number of software analysis tools (such as query language and programs) which enable us to understand the whole database architecture in both static and runtime modes. The Analytics sublayer ((c)(2)) allows users to probe the graphical database in Layer (b) and hence the digraph in Layer (a)(2) using a variety of algorithms, models, and tools. These graph algorithms should be able to cover multiple types of nodes in the digraph and the graphical database in the context of applications domains. The Visualization sublayer ((c)(3)) is able to filter and group the nodes in the database architecture attributes or indicators. It should be able to search for a particular function or services in the databases.

Figure 1: The Graph Model Framework:

(a) Graph Layer, (b) Database Layer, and (c) Interoperability Layer. Layer (c) has three sublayers: (c)(1) System analysis sublayer, (c)(2) Analytics sublayer, and (c)(3) Visualization sublayer.

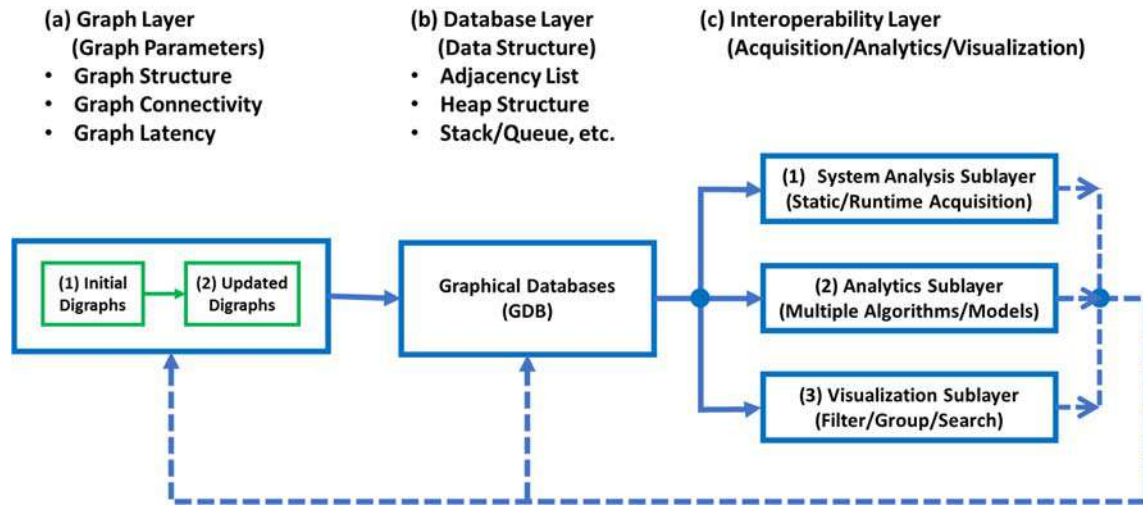

A SYSTEM EXAMPLE GA_1 WITH THREE USE CASES

In order to illustrate the graph model, we have designed and implemented a system (GA_1) which takes a digraph (at Graph Layer (a)(1)) as input and outputs a Directed Acyclic Graph (DAG) with the nodes in each strongly connected components (SCC) listed as a supernode. This system can take input files in format such as JSON and CSV and its visualization capability was implemented using Graphviz [9]. The system is written in C++ and the algorithm to compute strongly connected components is Tarjan’s algorithm [24]. We include three diverse use cases: a simple digraph G_1 , a random digraph G_2 , and a call graph G_3 using the designed system in the following subsections (3.1), (3.2), and (3.3) with digraphs of 15, 100, and 16 nodes respectively. In each of the three use cases, we illustrate each example with the following four graphs and figures: (a) the initial digraph, (b) updated DAG with super nodes shown, (c) indegree and outdegree distribution of the initial digraph, and (d) closeness and betweenness centrality distribution of the initial digraph. Closeness centrality is the average distance from a given starting node to all other nodes in the digraph. Betweenness centrality measures how often a node appears on shortest paths between nodes in the digraph.

In each digraph of the three use cases, we give the number of nodes, the number of edges, and the density of edges which is the ratio of number of edges over the total number of edges in the complete symmetric digraph. In addition, we count the number of maximal strongly connected components (SCCs). Moreover, we include average path length which is the average digraph-distance between all pairs of nodes and diameter which is the longest digraph distance between any two nodes in the digraph.

A Simple Digraph G_1

The initial digraph has 15 nodes, 24 edges, and density 0.114. It has 4 SCC’s. Its average path length is 2.433 and diameter is 6. The resulting DAG graph has 6 nodes and 9 edges. Four of the 6 nodes in the resulting DAG are super nodes each with a directed cycle of length 3 (see Figure 2 below).

Figure 2: A simple digraph with 15 nodes and 24 edges and its resulting DAG with 6 nodes and 9 edges: (a) Initial Digraph G_1 , (b) The Resulting DAG, (c) Degree Distribution, and (d) Centrality Distribution.

(a) Initial Digraph G_1

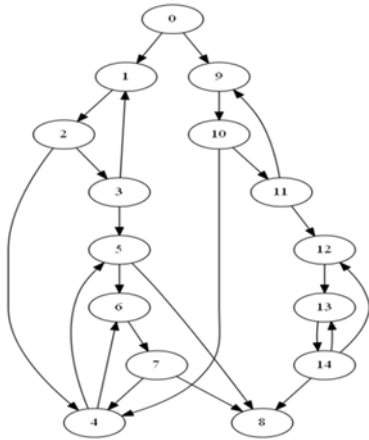

(b) The Resulting DAG

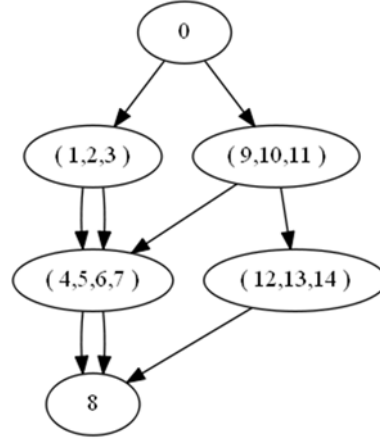

(c) Degree Distribution

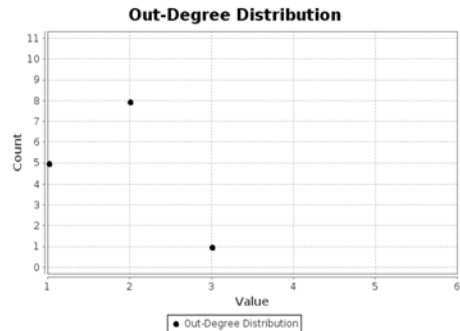
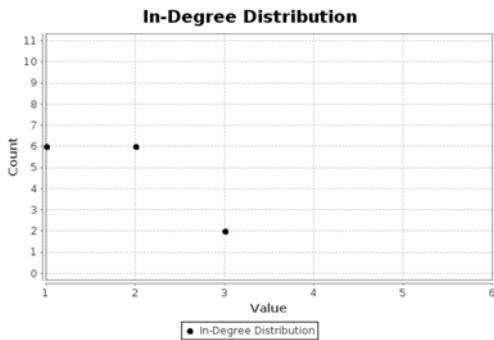

(d) Centrality Distribution

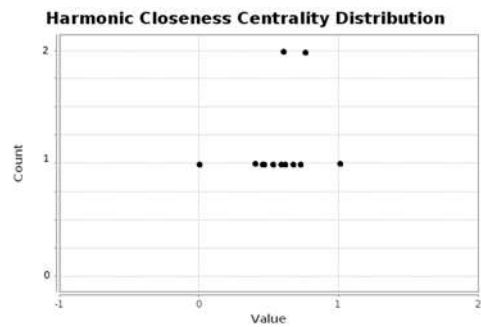
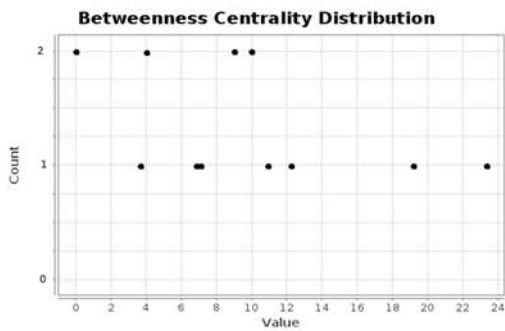

A Random Digraph G_2

The initial digraph has 100 nodes, 250 randomly generated edges, and density 0.025. It has only one SCC. It's average path length is 4.515 and diameter is 11. The resulting DAG graph has 14 nodes and 19 edges. Only one of the 14 nodes in the DAG graph is a supernode with 87 nodes in the SCC (See Appendix 1).

A Call Graph G_3

The initial digraph is a call graph representing some software procedure call graph in the library. It has 16 nodes, 16 arcs, and density 0.067. It has only one SCC. Its average path length is 2.296 and diameter is 5. The resulting DAG has 14 nodes and 13 edges. The only supernode has a directed cycle of length 3 (See Appendix 2).

CONCLUSION AND FURTHER WORK

In this paper, we provide a graph model framework for the design, implementation, analytics, and visualization of large and heterogeneous database architectures. The model consists of three layers: Graph layer, Database layer, and Interoperability layer. The model emphasizes that the design of data structure and query language for a graph database be more aware of the graph structure and properties (see the feedback loop in Figure 1). As such, the database management system (DBMS) can be enhanced by utilizing an abundance of previous results in graph theory and graph algorithms ([2, 8]). We also include a system example with three use cases to illustrate the graph layer of the proposed model.

Our current work is the beginning of an ongoing study on graph model for large and heterogeneous database architectures. There are several issues which deserve further study in the future. We highlight some of these directions in the following:

(a) Although the graph algorithm to compute strongly connected components we used in the system example (section 3) is based on the Tarjan algorithm [24], there are other algorithms [6, 15, 17, 19] with various data structures which are worthy of further investigation. We are particularly interested in algorithm and data structure which can identify and trace the directed loop structure at any supernode in the resulting DAG.

(b) At the Interoperability layer (c) and in general database management systems, several issues such as access control, concurrency control, and availability in the ACID property suit for a DBMS have to be addressed. For example, it was shown (see [10] and [23]) that their proposed VoltDB main memory DBMS can perform faster than traditional DBMSs such as DB2, MySQL and SQL Server on a certain class of applications.

(c) The third use case in the system example (section 3.3) concerns a call graph G_3 which is a combination of simple call graphs from three languages C++, JavaScript, and Python. This example illustrates the applicability of our graph model to data flow analysis in software engineering, compiler optimization, and software verification ([12]). This also raises the issue that the GDBMS in database Layer (2) should be able to accommodate multiple code bases and should not be restricted to any language.

(d) To perform large scale data analysis using massive parallelism to answer complex join queries over multiple database tables, a sequence of rounds, consisting of a communication phase followed by a computation phase, are needed ([18]). There is a growing need for single-round multi-join query evaluation where data is first re-shuffled through multiple servers and then evaluated in a parallel manner without any communication cost. Such a framework for reasoning about data partitioning was proposed recently under the Hypercube algorithm and other distributed policies [1]. We note that Hypercube is a graph structure with many good properties for parallel and distributed computing ([8]).

ACKNOWLEDGEMENTS

Authors of this paper are partially supported by a grant from Bloomberg LLC (grant #: DL-47359-15016). We are grateful to Tom Marshall and David Baird for fruitful discussions. The authors also acknowledge contribution of Gabriel Miller for his assistance in generating large random digraphs using Graphviz.

APPENDICIES

Appendix 1: Randomly generated digraph with 100 nodes and 250 edges and its resulting DAG with 14 nodes and 19 edges:

(a) Initial Digraph G_2 , (b) The Resulting DAG, (c) Degree Distribution, and (d) Centrality Distribution.

(a) Initial Digraph G_2

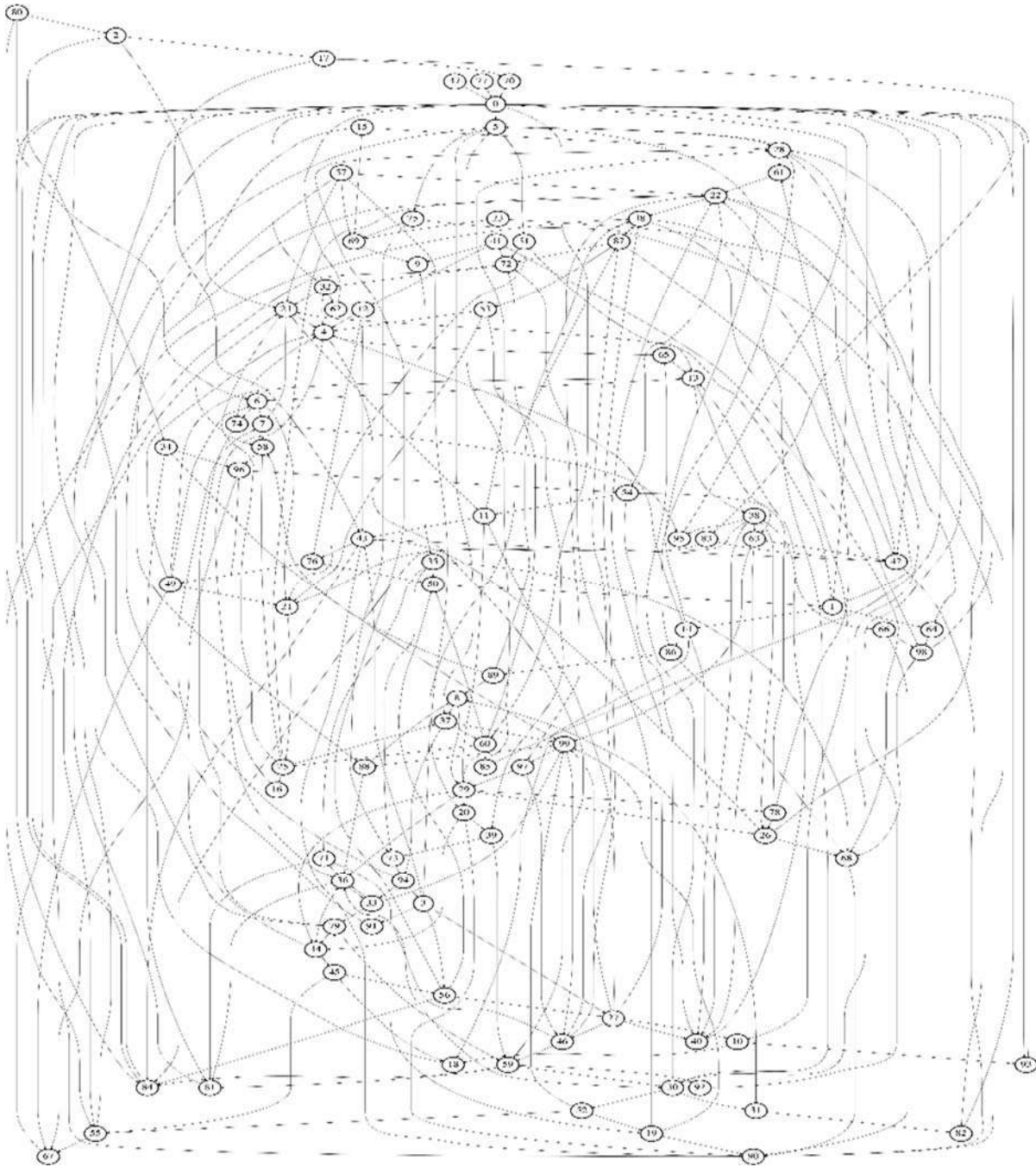

(b) The Resulting DAG

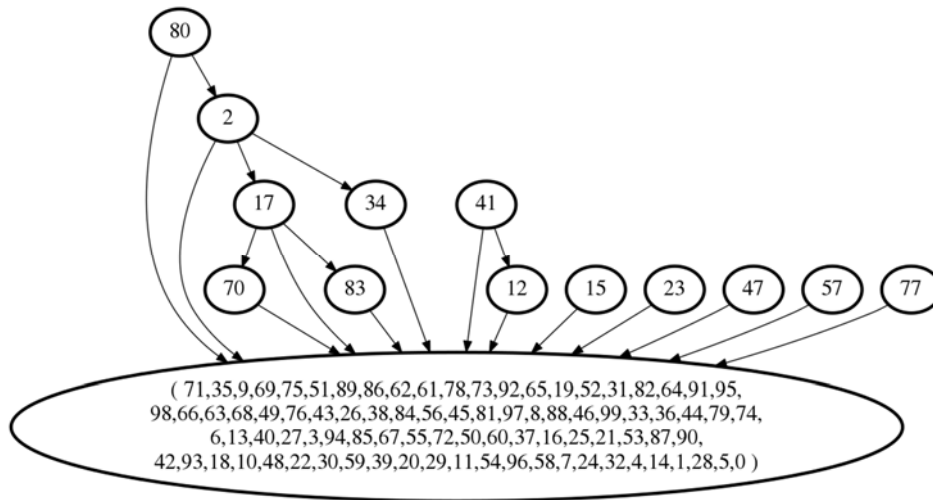

(c) Degree Distribution

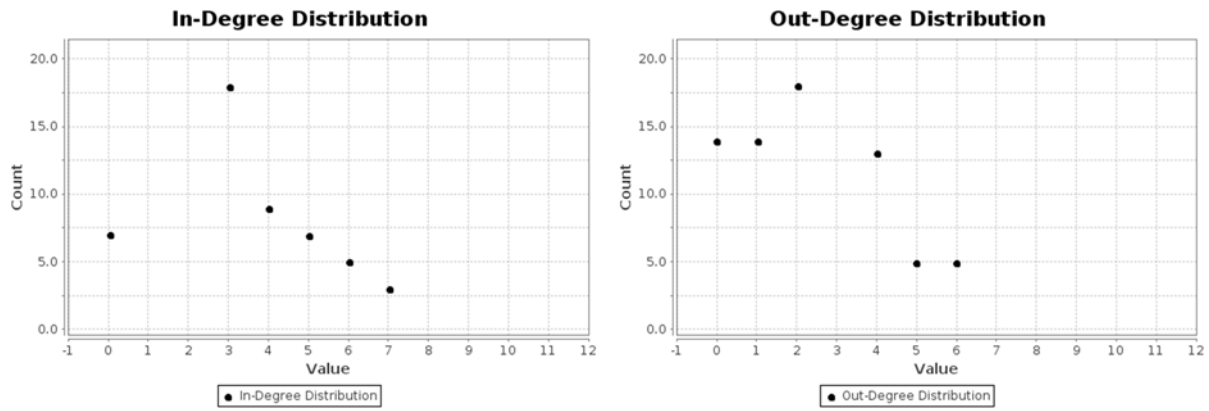

(d) Centrality Distribution

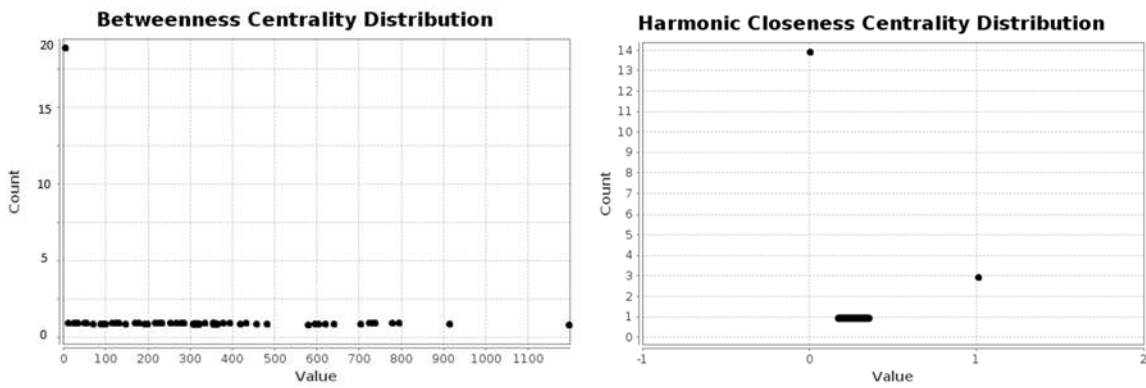

Appendix 2: A call graph with 16 nodes and 16 edges and its resulting DAG with 14 nodes and 13 edges:
 (a) Initial Digraph G_2 , (b) The Resulting DAG, (c) Degree Distribution, and (d) Centrality Distribution.

(a) Initial Digraph G_3

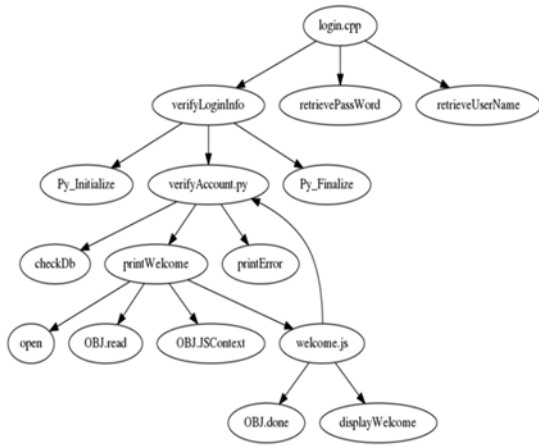

(b) The Resulting DAG

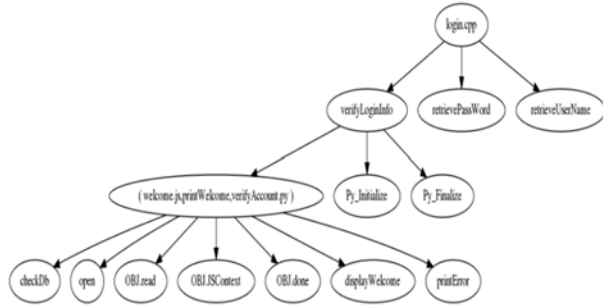

(c) Degree Distribution

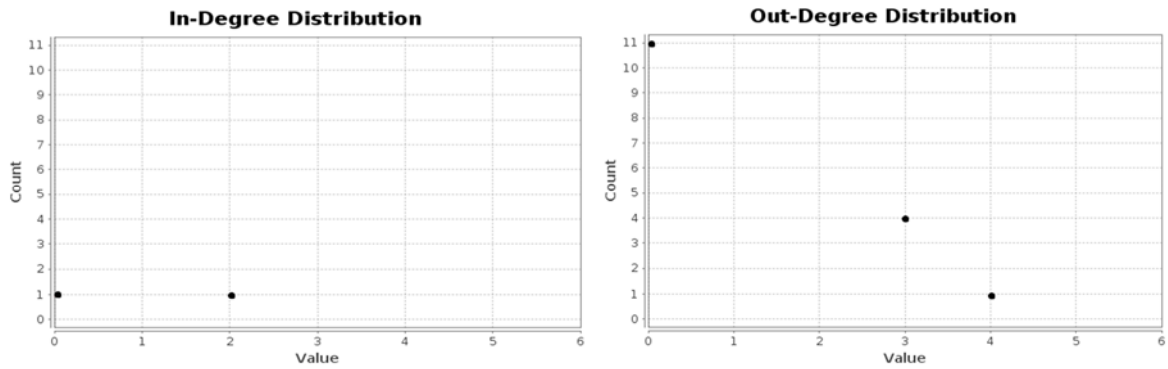

(d) Centrality Distribution

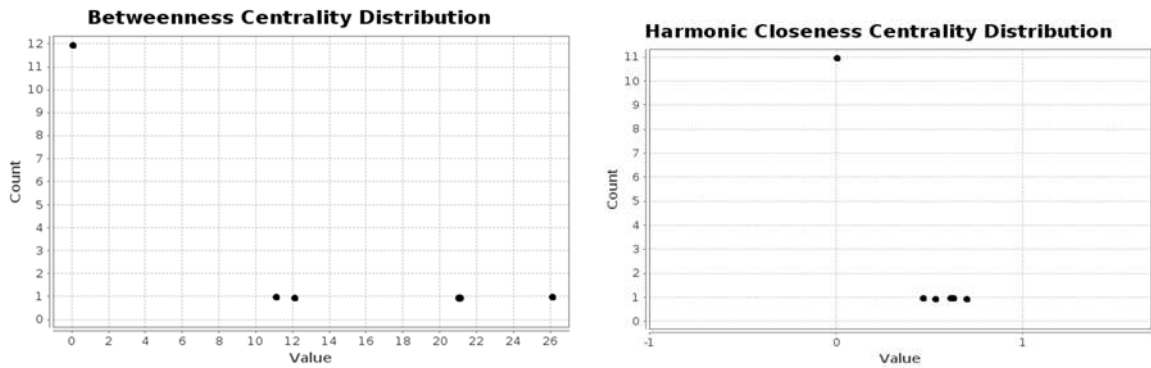

REFERENCES

1. Ameloot, T. J., Geck, G., Ketsman, Neven, B., F., & Schwentick, T. (2017). Reasoning on data partitioning for single-round multi-join evaluation in massively parallel systems. *Communications of the ACM*, 60(3), 93-100.
2. Bang-Jensen, J. & Gutin, G. Z. (2010). Digraphs: Theory, Algorithms and Applications, 2nd edition. *Springer-Verlay London*.
3. Brin, S. & Page, L. (1998). The Anatomy of A Large-Scale Hypertextual Web Search Engine. *Computers Networks and ISDN Systems*, 30(1-7), 107-117.
4. Chakrabarti, D., Zhan, Y., & Faloutsos, C. (April 2004). R-MAT: A Recursive Model for Graph Mining. *Proceedings of the 2004 SIAM International Conference on Data Mining (SDM), Orlando, FL.*, 442-446.
5. C++ Boost Library 1.64.0. <http://www.boost.org/>
6. Gabow, H. N. (2000). Path-based depth-first search for strong and biconnected components. *Information Processing Letters*, 74, 107-114.
7. Giraph. <http://giraph.apache.org/>
8. Grammatikakis, M. O., Hsu, D. F., & Kraetzl, M. (2000). Parallel System Interconnections and Communications. *CRC Press*, 412 pages.
9. Graphviz 2.38. <http://www.graphviz.org/>
10. Hellerstein, J. M. & Stonebraker, M. (edited). (2005). Readings in Database Systems, 4th Edition. *MIT Press*.
11. Hsu, D. F. (2015). Genome Assembly using Generalized de Bruijn digraphs, Chapter 7 in Next Generation DNA Sequencing Informatics (2nd edition edited by S. M. Brown). *Cold Spring Harbor Laboratory Press*, 127-139.
12. Khedker, U. P., Sanyal, A., & Sathe, B. (2009). Data Flow Analysis: Theory and Practice. *CRC Press*.
13. McColl, R., Ediger, D., Poovey, J., Campbell, D., & D. Bader, A. (2014). A Performance Evaluation of Open Source Graph Databases. *ACM PPAA'14, Orlando, FL.*, 11-18.
14. MultiThreaded Graph Library (MTGL) 1.1.1. <https://software.sandia.gov/trac/mtgl>
15. Munro, I. (1971). Efficient Determination of the Transitive Closure of a Directed Graph. *Information Processing Letter*, 1, 56-58.
16. NetworkX 1.11: <https://networkx.github.io/>
17. Purdom, P. W. (1968). A Transitive Closure Algorithm. *Tech. Report 33, Computer Science Department, Uni. Of Wisconsin, Madisen, WI.*
18. Ryze, S., Laserson, U., Owen, S., & Wills, J. (2015). Advanced Analytics with Spark: Patterns for Learning from Data at Scale. *O'Reilly*.
19. Sharir, M. (1981). A Strong-Connectivity Algorithm and its Applications in Data Flow Analysis. *Comp. & Maths with Appls.*, Vol. 7, 67-72.
20. Shiloach, Y. & Vishkin, U. (1982). An O(logn) Parallel Connectivity Algorithm. *J. Algs.*, 3(1), 57-67.

21. SQLite 3.18.0. <https://www.sqlite.org/>
22. STINGER 15.10.1. <http://www.stingergraph.com/>
23. Stonebraker, M. & Weisberg, A. (2013). The VoltDB Main Memory DBMS. *Bulletin of the IEEE Computer Society Technical Committee on Data Engineering*, 21-27.
24. Tarjan, R. (1992). Depth-First Search and Linear Graph Algorithms. *SIAM J. Comput.*, Vol. 1, No. 2, 146-160.

YOUTH ENTREPRENEURIAL INTENTION IN SOUTH AFRICA – A SYSTEMATIC REVIEW DURING CHALLENGING ECONOMIC TIMES

**Suzaan Hughes and Chris Schachtebeck
University of Johannesburg, South Africa**

ABSTRACT

South Africa is experiencing a challenging socio-economic climate characterized by low economic growth rates, high levels of poverty and unemployment, particularly prominent amongst South Africa's youth. Entrepreneurship is often seen as the solution to such problems, yet this is not reflected in the levels of entrepreneurship amongst the youth. This paper aims to systematically review the results of various studies on youth entrepreneurial intent in South Africa over a ten year period. The study was qualitative in nature and made use of a systematic review approach. Data were analyzed by means of a thematic content analysis. Findings were grouped into three themes; (1) the potential of education to unlock entrepreneurial intent, (2) Factors influencing entrepreneurial intent, (3) lack of support influencing entrepreneurial intent. The value of the studies lies in the fact that no studies in South Africa have reviewed the results of various studies on youth entrepreneurial intent over a period of time and categorized the findings in a holistic manner.

Keywords: entrepreneurial intention, youth, South Africa, systematic review.

INTRODUCTION

In South Africa the youth make up the majority of the population and as such their role in future economic growth cannot be overstated (Mahadea, Ramroop & Zewotir, 2011). The youth unemployment rate in South Africa averaged 51.14% between 2013 and 2016 (Trading Economics, 2017). The picture is even bleaker for school leavers who face an unemployment rate of 65.5% immediately after finishing school (Chutel, 2016). According to the World Economic Forum Global Risk report, South Africa has the third highest youth unemployment in the world for people between the ages of 15-24. This has led to unemployed youth being labelled the 'lost generation', they are also faced with increasing costs of higher education which creates unpayable debt as the chances of finding a job are low (Fin24, 2014).

While many African countries have experienced economic growth since the recession, the South African economy has battled to re-absorb the one million jobs lost as a result of the economic downturn (Chutel, 2016). According to the National and Provincial Labour Market: Youth report (South African Revenue Service: Youth, 2015) the youth have borne the brunt of the economic crisis created by the recession. Structural weaknesses in the South African labor market have created a perpetual mismatch between skills and available jobs with 36.4% of youth looking for a job only having a matric qualification and 55% not even having a matric. The effect of these challenges on society is also influenced by demographic variables, for example, 13,1% and 10.5% of black and coloured youth have skilled occupations, compared to 36.2% and 53.4% of Indian/Asian and white youth (South African Revenue Service, 2015). In view of this reality it is of no surprise that entrepreneurship is widely touted as the solution to the unemployment pandemic. If the youth do not find gainful employment or create their own self-employment opportunities, then social inequality is bound to persist. However, entrepreneurial intent that does not get translated into action offers no value in solving the problem of low total entrepreneurial action (TEA) and consequently also high levels of unemployment (Malebana & Swanepoel, 2015).

While a number of small-scale, isolated studies have been conducted focusing on entrepreneurial intent of the youth, there only exists one large-scale study which incorporates entrepreneurial intent of the youth, namely the Global Entrepreneurship Monitor (GEM) report. In order to more accurately gauge the entrepreneurial intent of the youth, particularly during turbulent economic times, this study makes use of a systematic review of South African studies which have attempted to describe and discover the dynamics of youth entrepreneurial intent. This study therefore conceptually bridges the gap by summarizing the results of relevant recent studies on entrepreneurial intent. The results allow for a better understanding of the dynamics influencing the translation of entrepreneurial intent into action.

PROBLEM STATEMENT

South Africa is currently facing a difficult economic reality, with declining rates of economic growth, high levels of joblessness and declining levels of economic participation by South Africa's population. One specific segment of the South African population that is experiencing very high levels of unemployment is the youth. One solution that has been touted to address these socio-economic challenges is the promotion of entrepreneurship, in order to create a higher number of small and medium-sized enterprises. In order to be able to identify the proportion of the youth that are able and willing to pursue entrepreneurship as a career path, it is of importance to interrogate the dynamics related to entrepreneurial intent of the youth. An analysis of this entrepreneurial intent allows governmental role players, industry and academia to focus on supporting this particular niche.

LITERATURE REVIEW

Entrepreneurial Intent

Entrepreneurial intention, or the motive to engage in a new business venture, can be regarded as the precursor to this type of behavior (Kibler, 2013). Jorge-Moreno, Castillo and Triguero (2012) suggest that in classical empirical literature, an individual's entrepreneurial intention is determined by means of two components, namely contextual factors, as well as personality characteristics or personal background. This view is supported by Solesvik, Westhead and Matlay (2014), who argue that an individual's personal environment, resources and processes have a strong influence on an individual's decision to pursue an entrepreneurial career path. Ajzen (2005) reports that entrepreneurial intention has three main influencing factors, namely individual attitudes, subjective norms and perceived behavioural control. Individual attitudes makes reference to the individual's understanding of a particular concept. Secondly, subjective norms make reference to the immediate social environment of an individual; and the influence this environment has on entrepreneurial decision-making. Thirdly, perceived behavioral control is also referred to as self-efficacy, i.e. the confidence and belief the individual holds in his/her own skills influencing their chances to succeed (Ajzen, 2005; Kibler, 2013). Remeikiene *et al.* (2013) list relevant factors as self-efficacy, propensity for risk-taking, need for achievement, internal locus of control, personal attitudes and behavioral control. Knowledge of the entrepreneurial intention of a country's citizens is important as it can predict levels of new business establishment, yet Arrighetti, Caricati, Landini & Monacelli (2016) argue that relatively few studies have attempted to describe the relationship between economic development and entrepreneurial intent, yet this is particularly important due to the economic crises many developing and developed economies currently face.

Realities of The Entrepreneurial Eco-System In South Africa

The Global Entrepreneurship Monitor (GEM) report was first published in 1997 and has developed into one of the world's most comprehensive reports aiming to improve the understanding of entrepreneurship (Herrington & Kew, 2016). The comprehensive data derived from the GEM report is of particular importance as there exists a severe lack of reliable statistics on entrepreneurship and SMEs in South Africa (Timm, 2011). The lack of reliable statistics provides difficulties for policymakers, as "we don't know how many small businesses there are, how many people they employ, or what the sector contributes to GDP...you can't have evidence-based policy in the absence of evidence" (SBP, 2009, p. 3).

South Africa's entrepreneurial eco-system provides the framework in which SMEs and entrepreneurs operate. Yet the results of the GEM report show that South Africa is highly deficient in a number of areas, when compared to the GEM average and other efficiency-driven economies. South Africa scores poorly in terms of having supportive government policies and tax frameworks (3.1 out of 9), supportive government entrepreneurship programs (3.0 out of 9), internal market burdens (3.9 out of 9) and unsupportive cultural/social norms (3.4 out of 9). More positively, SMEs and entrepreneurs have access to good physical infrastructure (5.9 out of 9). Areas for improvement include; offering better financial support (4.0 out of 9), as well as improving access to entrepreneurship education at professional and vocational-level (4.2 out of 9). Overall, South Africa's performance in the above-mentioned areas, which influence the entrepreneurial eco-system, has deteriorated substantially over the past few years (Herrington & Kew, 2016).

Youth Entrepreneurial Activity - The Status Quo

The youth, namely those up to 34 years of age, make up the majority of the unemployed. According to the strict definition of unemployment, i.e. those who are able, willing and actively seeking employment, 47.6% of youth were unemployed at the end of 2016 (Statistics South Africa, 2016). According to the expanded definition, approximately 60% of South Africa's youth are unemployed (Herrington & Kew, 2016). Unemployment levels amongst the youth without a school leaving certificate, such as a matric, paint a bleak picture, with 57% of the youth without a matric being unemployed, and 38% of those possessing a matric being unemployed (Statistics South Africa, 2016). In terms of entrepreneurial activity, the 2016/17 Global Entrepreneurship Monitor report shows that South Africa is ranked 40th out of 63 economies in terms of entrepreneurial education at school stage. Steenekamp *et al.* (2011) explain that entrepreneurship needs to be fostered at secondary school level already, for meaningful change to occur. Prevalence and performance of entrepreneurial education at primary and secondary level is poor, with a score of 3.1 out of 9. Entrepreneurship education at vocational, professional and tertiary-level fared slightly better, albeit at a much lower level than other efficiency-driven economies (4.2 out of 9) (Herrington & Kew, 2016). Table 1 outlines the TEA by age group, as reported in the 2015/16 South Africa GEM report. The table reveals that the TEA of the youth shows that while there has been an improvement between 2009 and 2013, the youth TEA dropped in 2014, with a marginal improvement in 2015. It is further noteworthy that the youth TEA is significantly below the Africa average, and even lower than the average for other efficiency-driven economies.

Table 1: TEA by age group in South Africa

	2009	2011	2012	2013	2014	2015	Africa (average)
18 - 24 years	4.7	6.8	5.0	7.8	4.8	6.3	15.0
25 - 34 years	7.4	10.2	9.0	14.1	9.0	10.9	24.0

Source: Adapted from Herrington & Kew (2010; 2016)

RESEARCH METHODOLOGY

This research is qualitative in nature and utilized a systematic review methodology. A systematic review was selected in order to effectively synthesize the results of a number of studies. The systematic review was guided by the question: 'What factors explain the challenges and opportunities that influence youth entrepreneurial intent in South Africa over the past 10 years?'. In order to discover and effectively frame the research topic, a number of key words were utilized to guide the research process. Relevant **keywords** for the study included the terms '**entrepreneurial intent**', '**entrepreneurial intention**', '**South Africa**' and '**youth**'.

To discover the widest possible range of data sources, a number of prominent databases housing a large quantity of South African research were included as data sources. These databases included; *Sabinet African Electronic Publication (SAePublications)*; *Ebscohost (Academic Source Complete & Business Source Complete)*; *Emerald Insight*; *Proquest Business Collection*; *Springerlink*; *Gale Business Insights*; *Sage Journals Online*; *Researchgate*; *Taylor & Francis*; *Science Direct*; *Credo Reference*, and *De Gruyter Journals Online*. The database search commenced on the 18th of February 2017. The initial search utilized Boolean operators. In order to suit individual databases, Boolean operators were adapted for each database. Also, date ranges between 2008 and 2017

were specified for each database. A primary search string was developed which reflected the keywords for the study. The primary search string is as follows: (“*entrepreneurial intent*” OR “*entrepreneurial intention*”) AND (“*South Africa*”) AND (“*Youth*”).

Prior to the initial search, exclusion and inclusion criteria were developed. Inclusion criteria included articles: being available in English or Afrikaans; available as full-text; the focus of the study being entrepreneurial intention; the study being conducted within the bounds of South Africa; the study being conducted between 2008 and 2017. Studies were excluded when they were: not available as full text, i.e. only abstracts; articles not written in English or Afrikaans; not focused on entrepreneurial intention; conducted outside of South Africa; contain only secondary research; conducted prior to 2007. The detailed search process was depicted graphically after initial searches were completed. Data obtained from the database search were tabulated (see table 2). The findings and conclusions of the articles were then analyzed by means of a thematic content analysis.

FINDINGS

A total of 1433 articles were discovered during the systematic review process. Articles which were only available as abstracts, were written in a language other than English and which were conducted outside of South Africa were discarded (548 articles). 62% (885 articles) of the remaining articles were written in English and available as full-text. Further in-depth analysis of these discovered articles revealed that only 3% (24 articles) were regarded as relevant in terms of meeting all inclusion criteria. Two of the 26 discovered and relevant articles were discarded as they were duplicates. 853 articles were regarded as not relevant, mainly due to studies being conducted outside of South Africa, not focusing on the youth, not investigating entrepreneurial intention and not conducting primary research. The article discovery process is depicted in Figure 1.

Figure 1: Overall systematic review statistics

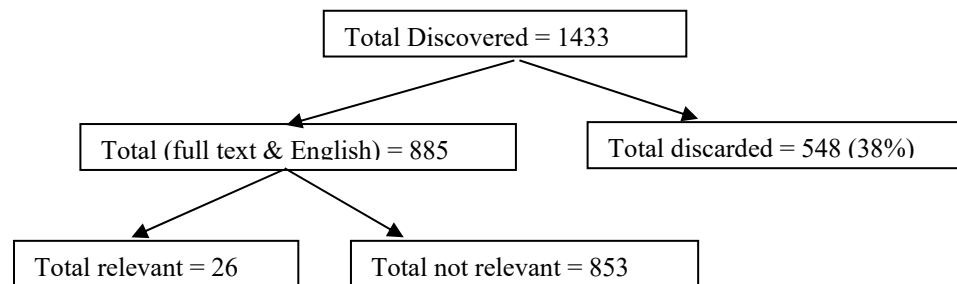

Source: Authors' calculations

A detailed overview of the preliminary results is presented in Table 2.

Table 2: Preliminary Results of Systematic Review

Database	Date of search	Total Discovered (Stage 1)	Meet inclusion criteria (Stage 2)	Not accepted (Stage 3)	Accepted (Stage 3)
Ebscohost	18/02/2017	184	163	159	4
Sabinet	18/02/2017	134	128	119	9
Emerald	18/02/2017	202	82	81	1
Proquest	18/02/2017	728	346	339	7
Springerlink	18/02/2017	45	45	45	0
Gale	18/02/2017	16	16	16	0
Sage	18/02/2017	103	88	86	2
Researchgate	21/02/2017	4	4	3	1
Taylor & Francis	21/02/2017	9	7	6	1
Science Direct	22/02/2017	8	6	5	1
Credo Reference	21/02/2017	0	0	0	0
De Gruyter	21/02/2017	0	0	0	0
Sub-total		1433	885	859	26
Duplicates					2
Total					24

Source: Authors' calculations

The research findings, conclusions, implications and recommendations of the articles were analyzed in order to gain insight into the reasons for the levels of entrepreneurial intent. Three major themes were discovered, each containing explanations for the prevailing level of entrepreneurial intent. An overview of the themes is presented in figure two.

Figure 2: Themes explaining the prevailing level of entrepreneurial intent

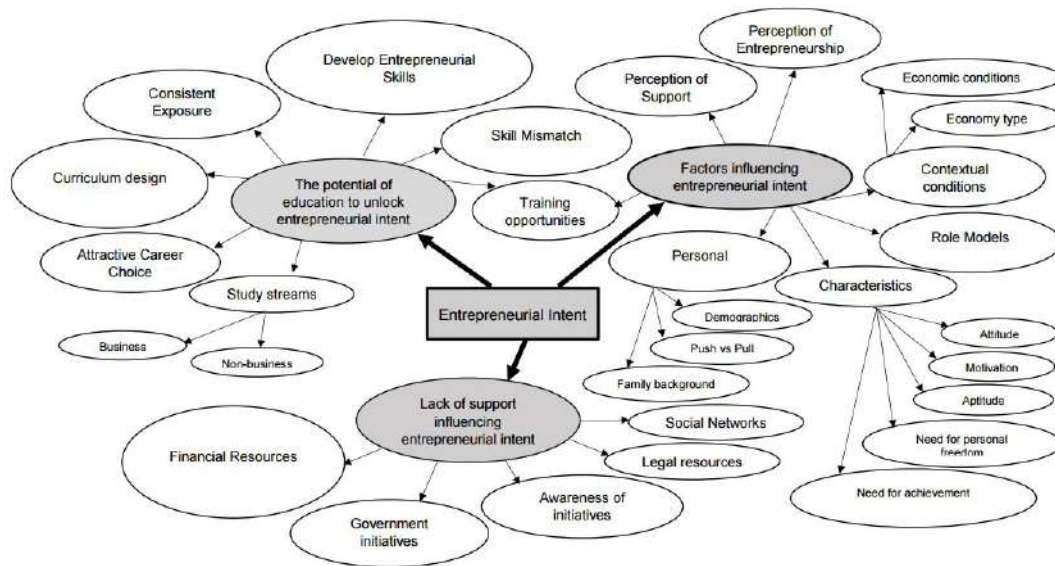

Source: Authors' findings

Each theme is mapped to the major issues, implications and recommendations with the size of the bubbles denoting how frequently the components were mentioned in the discovered articles. The findings for each theme are discussed in more detail below.

Theme 1: The potential of education to unlock entrepreneurial intent

The articles all advocated the role entrepreneurship education plays in increasing intent and conceptually many articles drew the link between entrepreneurship education and the potential efficacy future entrepreneurs would have if the necessary skills were developed. The phrase entrepreneurial education was found to be a catch-all phrase. Firstly, the articles referred to the development of skills that students would need to become entrepreneurs. Content related competencies and skills that were identified as needing to be developed include; marketing, management, time management, leadership, communication and financial literacy. Personal skills that were identified include; building self-confidence, responsibility, independence, risk-taking, developing an entrepreneurial mind-set, creativity, innovation, entrepreneurial self-efficacy and developing academic resilience. The first major sub-theme can be labelled “entrepreneurial interventions”, the articles analyzed presented different perspectives, ranging from business simulations to product design competitions. The authors proposed that interventions should be embedded in education from early on, be embedded in a variety of subjects, must be value adding and ideally experiential. The interventions sub-theme also includes the findings for studies that encouraged a re-examination of the curricula necessary to cultivate creativity and innovation amongst students. In this vein several authors advocated curriculum redesign in order to incorporate the necessary entrepreneurial approaches. Another important suggestion made in five articles is that students need to be informed that they can develop the necessary attributes, youth that indicated they did not believe they had the necessary attributes already also had lower entrepreneurial intent. Four articles stated the need to present entrepreneurship as an attractive career option, in this regard educators have an important role to play in providing a realistic and balanced view of the challenges and opportunities entrepreneurs would likely face. Presenting entrepreneurship as an attractive career option is closely linked to the role models that the youth have. Three articles pointed out the value of a role model in encouraging the youth to attempt entrepreneurship and suggested that educators use local examples and potentially arrange talks by entrepreneurs or set up mentoring opportunities. One article advocated for a database of retired entrepreneurs to be compiled, so that experienced entrepreneurs with more time on their hands could provide mentorship and coaching to potential entrepreneurs.

Theme 2: Factors influencing entrepreneurial intent

The analysis of the discovered articles reveals that different authors found a number of elements influencing entrepreneurial intent. Perceptions of entrepreneurship, from the individual youth’s point of view, held a strong influence on entrepreneurial intent. Perception refers to the opinion, regard and understanding the youth have of entrepreneurship. A positive perception of entrepreneurship indicated a stronger entrepreneurial intent. Similarly, role models, whether these have an entrepreneurial connection or not, have a strong influence on the individual perception of entrepreneurship and therefore also influenced entrepreneurial intent. The lack of role models was shown to very strongly negatively influence entrepreneurial intent. Contextual factors were also shown to influence entrepreneurial intent. Discovered contextual factors included items such as supportive economic conditions, as well as the type of economy. A developing economy context was shown to have a positive influence on entrepreneurial intent. Personal factors also acted as strong influences of entrepreneurial intent. Two studies indicated that males exhibit higher entrepreneurial intent than their female counterparts. Also, in the South African context race played an important component in determining entrepreneurial intent, with studies indicating that Black Africans exhibiting higher entrepreneurial intent than other race groups. Having a family background in entrepreneurship also positively impacted entrepreneurial intent of the youth. In terms of motivational factors, youth who possessed a strong need for achievement, as well as a need for personal freedom, displayed higher levels of entrepreneurial intent. Lastly, youth who had exposure and access to entrepreneurial training initiatives displayed higher levels of entrepreneurial intent.

Theme 3: Lack of support influencing entrepreneurial intent

The biggest reason cited by respondents in the articles for not starting a business is a lack of financial resources. One article found that respondents that had started a new venture were far less likely to identify a lack of finance as an obstacle to becoming an entrepreneur. One article focused on the institutional barriers that youth entrepreneurs face and identified a lack of legal resources, complex regulations for starting a business, weak property rights, heavy business regulation and the high cost of regulatory compliance as hurdles. Two articles specifically mentioned that

legislation in South Africa needs to be more ‘entrepreneurially friendly’ in order not to negatively affect the intention of youth to become entrepreneurs. Several articles identified the importance of relevant networks in encouraging entrepreneurship. One article emphasized the importance of social networks, with another article drawing specific attention to the role of family support. Predominantly, support from ‘relevant networks’ were identified as access to development corporations, partnerships between higher education and government institutions and government agencies that support and facilitate entrepreneurship. A lack of trust of government initiatives was identified as a hurdle in two articles. Four articles pointed out that there was a lack of awareness of what support was available to potential entrepreneurs as well as how they could access support. Two articles identified a sense of entitlement and a culture of dependency in South Africa as a hurdle, explaining why more youth are not considering a career in entrepreneurship. One article advocated that the government should play a role in changing this mindset by informing the youth that the payment of social grants is not sustainable and should not be relied on indefinitely.

CONCLUSION

The purpose of this study was to systematically review studies which focused on entrepreneurial intent of the South African youth, viewed in context of South Africa’s socio-economic situation. The study found that limited research has been conducted into entrepreneurial intent of the South African youth. This finding is concerning when viewed relative to the difficult status quo the South African youth find themselves in. The themes identified from the research studies revealed sentiments that echo the findings of the GEM report. The GEM report identifies access to entrepreneurship education as an area for improvement and the corresponding emphasis that the articles studied place on the role of education is well matched to the potential that education has to unlock entrepreneurial talent. The contextual factors that influence entrepreneurial intent are well documented. While certain demographic factors are fixed other factors, such as exposure to entrepreneurship, can be positively influenced by appropriate interventions. A lack of support ranging from family support all the way to access to financial resources further explains some of the important factors inhibiting the conversion of intention into action.

IMPLICATIONS AND RECOMMENDATION

The results of the study benefit a variety of stakeholders, such as policy-makers and universities. Policy-makers will have a better understanding of the range of studies conducted over the past ten years, thus allowing for more tailored and effective policy interventions. The results further aim to focus the efforts of stakeholders on promoting entrepreneurship amongst the youth, in order to address the difficult socio-economic realities South Africa faces. In this vein, the following recommendations can be made:

Theme 1: Recommendations for the education sector

Educators have to nurture an entrepreneurial mindset and develop entrepreneurial skills. Further, in many of the studies, entrepreneurship was not perceived as a viable and attractive option. Educators have a role to play in presenting entrepreneurial role models and communicating to students that it is a rewarding career option. Lastly, students need to be exposed to entrepreneurial interventions, learning experiences that prime them for creative responses. These interventions should be focused in nature and exposure to entrepreneurship should be embedded in several courses throughout secondary and higher education.

Theme 2: Recommendations for civil society

Firstly, the lack of role models presents a strong obstacle to future entrepreneurial action. A database of experienced entrepreneurs can be compiled, thus making experienced entrepreneurs available to provide mentorship and coaching to potential entrepreneurs. Secondly, family background in entrepreneurship and previous self-employment exposure influence potential future entrepreneurial action. Students, and the youth in general, should be encouraged and incentivized to start “trial ventures” to gain experience, fail and learn in order to motivate them to start more significant business ventures at a later point.

Theme 3: Recommendations for the public and private sector

The level of awareness around government initiatives and support networks is low. Targeted public relations campaigns need to clearly communicate available support mechanisms. Lastly, lack of access to financial resources remains the biggest hurdle to entrepreneurial start-ups, however entrepreneurial intent impacts the perception of the hurdle. Whilst a lack of access to finance needs to be addressed, it is recommended that the entrepreneurial orientation of potential entrepreneurs is developed so that innovative responses to lack of resources can prevail.

REFERENCES

- Ajzen, I. (2005) Attitudes, personality and behaviour, 2nd edition, Berkshire: Open University Press.
- Arrighetti, A., Caricati, L., Landini, F. & Monacelli, N. (2016) Entrepreneurial intention in the time of crisis: a field study. *International Journal of Entrepreneurial Behavior & Research*, 22 (6), 835-859.
- Chutel, L. (2016) Record unemployment affects these South Africans the most. Available from: <https://qz.com/844825/southafricasunemploymentrateisata13yearhighmostaffectingwomenandtheyouth/> (Accessed 3 March 2017).
- De Jorge-Moreno, J., Castillo, L.L. & Triguero, M.S. (2012) The effect of business and economics education programs on student's entrepreneurial intention. *European Journal of Training and Development*, 36(4), 409-425.
- Fin24. (2014) SA youth unemployment 3rd highest in the world. Available from: <http://www.fin24.com/economy/sayouthunemployment3rdhighestinworld20140120> (Accessed 3 March 2017).
- Herrington, M. & Kew, P. (2016) 2015/16 GEM South Africa Report. Available from: <http://www.gemconsortium.org/country-profile/108> (Accessed 13 February 2017)
- Kibler, E. (2013) Formation of entrepreneurial intention in a regional context. *Entrepreneurship & Regional Development*, 25(3-4), 293-323.
- Mahadea, D., Ramroop, S. & Zewotir, T. (2011) Assessing entrepreneurial perceptions of high school learners in Pietermaritzburg, KwaZulu-Natal. *South African Journal of Economic and Management Sciences*, 14(1), 66-79.
- Malebana, M, J. & Swanepoel, E. (2015) Graduate Entrepreneurial intentions in the rural provinces of South Africa. *South African Business Review*, 19(1), 89-111.
- Remeikiene, R., Startiene, G. & Dumciuviene, D. (2013) Explaining entrepreneurial intention of university students: the role of entrepreneurial education. *Zadar: Active citizenship by knowledge management & innovation*.
- SBP. (2009) Accelerating small business growth in South Africa: A roundtable discussion. Available from: http://www.sbp.org.za/uploads/media/SBP_alert_-_Accelerating_Small_Business_Growth_in_South_Africa.pdf (Accessed 13 February 2017)
- Solesvik, M., Westhead, P. & Matlay, H. (2014) Cultural factors and entrepreneurial intention: The role of entrepreneurship education. *Education + Training*, 56(8/9), 680-696.
- South African Revenue Service. (2015) National and Provincial Labour Market: Youth. Available from: <http://www.statssa.gov.za/publications/P02114.2/P02114.22015.pdf> (Accessed 3 March 2017)
- Statistics South Africa. (2016) Quarterly Labour Force Survey. Available from: <http://www.statssa.gov.za/publications/P0211/P02113rdQuarter2016.pdf> (Accessed 1 March 2017)

Steenekamp, A.G., Van der Merwe, S.P. & Athayde, R. (2011) An investigation into youth entrepreneurship in selected South African secondary schools: an exploratory study. *Southern African Business Review*, 15(3), 46-75.

Timm, S. (2011) How South Africa can boost support to small businesses: Lessons from Brazil and India. Available from: http://www.tips.org.za/files/india_brazil_2011_edit_s_timm.pdf (Accessed 13 February 2017).

Trading Economics. (2017) South Africa youth unemployment rate. Available from: <http://www.tradingeconomics.com/southafrica/youthunemploymentrate> (Accessed 3 March 2017).

THE RELEVANCE OF INFORMATION SOURCES IN THE MARKETING OF INDEPENDENT PRIMARY SCHOOLS IN SOUTH AFRICA

Reaan Immelman and Mornay Roberts-Lombard
University of Johannesburg, South Africa

ABSTRACT

The objective of the paper is to investigate the relevance of the sources of information considered by parents in the selection process of independent primary schools in South Africa. This objective was achieved by identifying the information sources influencing prospective parents' independent school choice and the relevant importance of these information sources. The methodology followed was quantitative and exploratory in nature. The sample consisted of 669 respondents from 30 independent schools in Gauteng province of South Africa. Descriptive statistics and factor analysis was used to analyse the results. A total of 19 information sources were identified when parents select independent primary schools, and the most important information source was school open days, with social media indicated as a less preferred choice. However, the relevance of social media cannot be underestimated, due to the growth of social media as a marketing tool.

Keywords: School marketing, consumer behaviour, information sources, integrated marketing communication.

INTRODUCTION

The South African education system consists of two categories of schools, namely public schools and independent schools (Fedsas, 2015). The number of independent schools, also referred as private schools by most parents in South Africa, has grown from 518 in 1994 to 1 681 independent schools in 2014 with the majority of these schools (651) in the Gauteng province (Department of Basic Education, 2014). This growth is driven by a growing middle class in South Africa preferring high quality education, and the fact that the government is not building new schools in affluent areas (Hasenfuss, 2011). It could also be an indication that parents are losing faith in the public school system (IFC, 2011). Prospective parents can enroll their child at any school in South Africa and parents are not forced to do such enrolment at the nearest school, but have a choice to enroll their child at their school of preference (Van Wyk and Bischoff, 2012). Competitiveness in the independent school sector is furthermore compounded by the growth of independent school groups, such as AdvTech who announced that its shareholders have approved the R450 million acquisition of the Maravest group of schools and Curro Holdings (Thomas, 2015).

LITERATURE STUDY

Literature on school marketing originated in the United States of America and the United Kingdom and themes covered by research in school marketing include the attitudes of school principals and other stakeholders towards the concept of marketing, the lack of research in school marketing and general literature on "How to market your school?" (Oplatka and Hemsley-Brown, 2004). School marketing is defined as the means by which the school actively communicates and promotes its purpose, values and products to learners, parents, staff and the wider community (Sferle, Gardan, Gudei and Geangu, 2012). Due to the intangible characteristics of education as a service

(Cant and Van Heerden, 2010) the services marketing mix consists of product, price, IMC, distribution, process, people and physical evidence (Soedijati and Pratminingsih, 2011). Parents investigate all possible sources of information such as school open days, school website and social media, and for the purposes of this paper, IMC will be discussed. Advertising can include magazine advertisements such as the South African Schools Collection which is a prestigious annual showcase publication targeted primarily at parents who need to make important decisions concerning their children's future (South African Schools Collection, 2010). Another form of advertising is local newspaper advertisements (Krugerddorp News, 2015) as well as outdoor signage in the form of street pole advertising (Smith, 2015). Sales promotion can be in the form of bursaries to learners for academic, leadership, sport or cultural excellence (Greyling, 2013). An example of events and experiences would be where the school hosts a sport festival such as the annual St John's and St Stithians sport festivals in Johannesburg (Irvine, 2013) and direct marketing in a school's context can be prospective parents visiting an education expo (Education Week, 2015). Interactive marketing is usually the school website (Foster, 2010) and a school open day is an example of personal selling where presentations are done to prospective parents (Lombard, 2013). A final IMC method is word-of-mouth and as traditional advertising has lost its power, the recommendations, suggestions, advice of friends and family gained importance in the buying decision process of consumers (Kalpaklioglu and Taros, 2011). The majority of parents will investigate what schools can offer their child, and therefore information sources are important when selecting independent schools.

Research into information sources influencing parents' choice of independent schools is limited and includes international studies by (Independent Schools Queensland survey, 2011; Independent Schools Council of Australia, 2008; Gorard, 1999). The Independent Schools Queensland survey (2011) identified amongst others the school open day, brochures, prospectuses, school websites, and school expos as most influential sources of information when searching for an independent school.

As far as could be ascertained, no research exists with specific reference to information sources considered in the selection of independent primary schools in the South African context, however research in South Africa on the topic of school marketing is presented in Table 1.

Table 1: School marketing studies in South Africa (2014-2015)

Topic	Source
Guidelines for the marketing of independent schools in South Africa	Immelman and Roberts-Lombard, 2015
A comparison of the marketing of independent schools in South Africa and the United Kingdom	Read and Bick, 2014
Boys' boarding school management: understanding the choice criteria of parents	Vigar-Ellis, 2013
A measuring instrument to determine the image of a high school	Van Wyk & Bischoff, 2012
A marketing strategy for independent schools	McAlister, 2005
The marketing of independent schools in Gauteng	Malberbe, 2004

PROBLEM STATEMENT AND OBJECTIVES

The changing independent school landscape in South Africa, with independent schools experiencing a strong growth of more than 300% since 1994, has encouraged schools to compete with each other. Prospective parents can choose from a variety of independent schools, especially in the Gauteng Province with the highest number of independent schools (651 or 39% of all independent schools) in South Africa (Department of Basic Education, 2014). To be sustainable in this competitive environment, it is imperative for independent schools to market themselves. However, some independent schools in South Africa find it difficult to market themselves successfully as a result of

a lack of information pertaining to the information sources considered by parents when selecting independent schools (Fourie, 2014). It is therefore important for independent schools to understand the information sources influencing parents' choice of independent primary schools because it will assist them in the development of their marketing communication strategy. Traditional communication tools such as advertising is expensive and independent schools need to investigate more cost effective ways, such as social media, to communicate to parents. The objective of the study is to investigate the relevance of the sources of information considered by parents in the selection process of independent primary schools, with specific focus on social media as communication tool to prospective and current parents

METHODOLOGY

The empirical investigation was exploratory and quantitative in nature. The population comprised all grade one parents from the 651 independent primary schools in the Gauteng Province. A non-probability sampling approach was followed and the judgment sampling technique was applied. The data was gathered over a twelve-week period in 2012. During this time, the father, mother, or guardian of the child in grade one who matched the sampling frame was asked to participate in the survey. A structured questionnaire, with a five-point Likert scale, was used to gather the data. Respondents were provided with a self-administered questionnaire or an Internet computer-assisted survey and the questionnaire included self-developed items. Suitable scale items considered reliability and validity was established. Items were developed from the literature review conducted to identify the information sources influencing parents' choice of independent primary schools as well as information gathered from interviews with parents. A total of 669 questionnaires were completed and could be used in the analysis. The questionnaire was pretested in a pilot study involving ten respondents from different independent primary schools in the Gauteng Province who matched the sampling frame. The internal consistency reliability test was used to measure reliability. Validity was ensured by having the content of the questionnaire aligned with the research objectives. The data obtained from the questionnaires was coded, captured, and edited and the statistical package for Social Sciences (SPSS version 18) was used (Pallant, 2013) to analyse the results. Factor analysis was used to assess the structural validity of the questionnaire and Exploratory Factor Analysis (EFA) was conducted to uncover the underlying structure of constructs. Respondents identified 19 information source variables and these variables are categorised into four factors, namely public relations and interactive marketing, advertising, personal selling and word-of-mouth marketing (Table IV).

RESULTS

Reliability and validity

Cronbach's alpha was used as a measure of the internal consistency reliability for the measurement of the importance of the attributes. The Cronbach's alpha coefficient for all constructs investigated (public relations and interactive marketing, advertising, personal selling and word-of-mouth) is above the limit of acceptability of 0.70. Validity can be attained by aligning the content of the questionnaire with the research objectives (Van Tonder & Ehlers, 2011, p.64). Consequently, the following activities were performed to ensure validity and reliability:

- A self-administrated questionnaire was designed, which was directly aligned with the research aim and objectives.
- A sufficiently large sample size was used to increase the accuracy of the results.
- The expertise of STATKON (the Statistical Consultation Services) of the University of Johannesburg was employed to analyse the data gathered and to ensure the correct measurements of the results.
- Factor analysis was used to assess the structural validity of the information sources construct and exploratory factor analysis was used in an attempt to gain insight into the structural validity. The 19 items of the information sources scales are suitable for factor analysis (KMO of 0.896 which is > 0.6 and Bartlett's test of Sphericity is 0.000, which is smaller than 0.05 (Pallant, 2013:187).

- Communalities provide information about how much of the variance in each item is explained. Four factors explain a total of 61.68% of the variance. Factor 1 (or component) contributes 42.51%, factor 2 contributes 52.07%, factor 3 contributes 57.92% and factor 4 contributes 61.68% of the total variance explained.

Demographic profile of respondents

Considering that a total of 669 respondents participated in the study, 77% were female, 84% were married, and 43% had English as their home language. The majority of the respondents (53%) earn a gross income of more than R45 000 per month and 84.2% have a post-matric qualification. Concerning the research objective, respondents identified 19 variables that they considered as valuable information sources when making a decision regarding the independent primary school at which they chose to enrol their child. These variables are categorised into four factors and is presented in Table V. From Table V, the main finding is that personal selling (School exhibitions, school open day and promotional DVD) realised an overall mean score above 3. The other factors realised a mean score below 3, although some components of the factors realised a mean score above 3 (school website, mean = 3.45 and word-of-mouth, mean = 3.31). It is interesting to note that all components of advertising have a mean of less than 3 with outdoor signage (e.g. street pole advertising) the highest mean of 2.60. Although the word-of-mouth overall factor is of less importance as information source (mean = 1.85), person-to-person word-of-mouth is the third most important information source (mean = 3.31) when all individual components of information sources are evaluated. Social media (Facebook, Twitter, LinkedIn, and YouTube) realised a mean score of below 2. Although social media have the lowest mean score, it can be the greatest opportunity for schools to market their school to prospective parents. These opportunities will be discussed in managerial implications and recommendations

MANAGERIAL IMPLICATIONS

Word-of-Mouth (Including Social Media)

In the light of the findings, it is clear that word-of-mouth (person-to-person) is the third most important information source. Word-of-mouth in the form of friends, work colleagues and other parents was cited as very important in the Independent Schools Queensland Survey (2011) while Gorard (1999) identified word-of-mouth by other parents as the fourth important information source. It can be assumed that ensuring satisfied current parents, learners and the alumni of the school will lead to positive word-of-mouth. It is recommended that if independent schools want to determine what is currently said about their school, it can be done by conducting marketing research (e.g. questionnaires or focus groups). Another recommendation is that current parents can be encouraged to bring along their friends to open days, or some parents can be brand ambassadors for their school. The other word-of-mouth elements are referred as social media and incorporate social media platforms such as Facebook, Twitter, YouTube and LinkedIn. This platform are of less concern to parents when selecting independent schools, but is the greatest marketing opportunity identified for independent schools due the growth of social media. Independent primary schools can integrate social media into their marketing and communications plans with the aim for parents to take part in the conversation and to build relationships with parents and other stakeholders. The following recommendations (inclusive of the application of social media tools) are provided to independent primary schools to assist them in the development of their marketing communication strategy.

Table 5: Information sources identified

Factor	Factor	Statement
Advertising (Mean = 2.37)	0.747	Magazine advertisements
	0.737	Radio advertisements
	0.707	Outdoor signage
	0.665	Local newspaper advertisements
	0.565	Brochures

Factor	Factor	Statement
Personal selling (Mean = 3.88)	0.809	Exhibitions
	0.745	Open day or information evening
	0.389	Promotional DVD
Interactive marketing and public relations (Mean = 2.95)	0.807	Fundraising activities
	0.695	Involvement in outreach programmes
	0.671	General school publicity
	0.597	Bursaries offered
	0.425	School website
	0.418	Cellphone marketing
Word-of-mouth marketing (Mean = 1.85)	0.911	LinkedIn
	0.866	Youtube
	0.804	Twitter
	0.783	Word-of-mouth (person-to-person)
	0.637	Facebook

RECOMMENDATIONS

Recommendation 1

Facebook users have more than doubled in a period of two years. In August 2014, 11.8 million South Africans were using Facebook compared to 5.3 million in 2012 (South African Social Media Landscape, 2015). It is therefore recommended that independent primary schools create their own School Facebook page, additional to their current website. Schools can also promote their service offering by means of Facebook Adverts where the adverts are shown to prospective based on their location, age and interests.

Recommendation 2

With YouTube's active user base of 7.2 million South Africans (South African Social Media Landscape, 2015) making it second in social network use in South Africa, it is recommended that independent primary schools create their own YouTube video and promote the school through this social media channel. The link to YouTube can be posted on either the school's Facebook page or Twitter account.

Recommendation 3

Twitter's previously dramatic rise has slowed down, although still growing by 20% in the past year, to 6.6 million users (South African Social Media Landscape, 2015). It is recommended that independent schools utilise Twitter as social marketing tool and although Twitter limits the character space in each tweet, that does not limit the potential an independent primary school can enjoy while incorporating Twitter into its marketing plan. Twitter differs from other social media channels because tweets are public, and anyone can follow a user.

Recommendation 4

The professional network LinkedIn has leaped by 40%, to 3.8 million users in South Africa (South African Social Media Landscape, 2015). A final recommendation is that the school utilise this social media platform to advertise vacant positions to recruit educators and other vacant academic positions. In this way, independent schools can reach more job applicants and can choose the best educators for recruitment.

LIMITATIONS OF THE STUDY AND FUTURE RESEARCH

The study focused on 30 independent primary schools in the Gauteng province of South Africa, representing 669 parents of a child enrolled in grade one. The study therefore cannot be seen as representative of the entire industry in the province or the country. As the study only focused on the Gauteng province and only independent primary schools, a more inclusive study of all provinces in South Africa (including high schools) is therefore recommended. It is also recommended that future research focus on high affluent independent schools in terms of school facilities.

CONCLUSION

The research succeeded in investigating the relevance of all possible sources of information when parents select independent primary schools. These information sources consist of advertising, personal selling, interactive marketing and public relations, as well as word-of-mouth. Although personal selling, and specifically school open days, is the most useful information source, the opportunity of social media is recommended for independent schools.

It is significantly more cost effective for independent schools to employ social media strategies than to consider other more expensive communication tools. Independent primary school should embrace social media in their marketing efforts and should include social media platforms such as Facebook, YouTube, Twitter and LinkedIn.

REFERENCES

- Cant, M.C. and Van Heerden, C.H. 2010. Marketing Management: A South African perspective. Cape Town: Juta & Co. Ltd.
- Department of Basic Education. 2014. School realities. Available: <http://www.education.gov.za/DocumentsLibrary/Publications> (accessed 28 May 2015).
- Fedsas. 2015. Documents. Available: <http://www.fedsas.org> (accessed 28 May 2015).
- Fourie, B.J. 2014. The success of Queens Private School (personal interview). 12 January. Johannesburg.
- Foster, B. 2010. School marketing manual for the digital age. 3rd ed. Benowa: School Marketing Australia Pty Ltd.
- Education week. 2015. Exhibitor List. Available: <http://educationweek.co.za> (accessed 18 May 2015).
- Gorard, S. 1999. Well, that about wraps it up for School Choice Research: a State of the Art Review. *Journal of School leadership and Management*, 19(1):25-47.
- Greyling, A.J. 2013. Bursaries for learners (e-mail). 30 August. Cape Town.
- Hair, J.F., Wolfinbarger, M.F., Ortinau, D.J. & Bush, R. 2010. Essentials of marketing research. 2nd ed. New York: McGraw-Hill.
- Hasenfuss, M. 2011. School fees paid: Will PSG make money out of private education? *Fin Week*: 14, 28 April.

- Immelman, R. & Roberts-Lombard. 2015. Guidelines for the marketing of independent schools in South Africa. *Acta Commercii*, 15(1): 1-9.
- Independent Schools Council of Australia. 2008. Factors affecting school choice. Available: <http://www.isca.edu.au> (accessed 31 October 2014).
- Independent Schools Queensland Survey. 2011. Available: http://www.aisq.qld.edu.au/files/Communications/survey/what_Parents_Want_SurveyReport-2011.pdf (accessed 23 May 2013).
- International Finance Corporation (IFC). 2010. Education Investment Guide. <http://www.ifc.org/wps/connect> (accessed 15 June 2013).
- Irvine, R. 2013. For the love of the game. *Financial Mail*: 19 April.
- Kalpakioglu, N.U. and Taros, N. 2011. Viral marketing techniques within online social network. *Journal of Yasar University*, 24(6): 4112-4129.
- Krugersdorp News. 2015. Curro Krugersdorp newspaper advertisement, 15 May.
- Lombard, A. 2013. Weekly open days [personal interview]. 20 July. Krugersdorp.
- Malherbe, P.J. 2004. The Marketing of Independent Schools in Gauteng. MCom Dissertation, Rand Afrikaans University, Johannesburg.
- McAlister, D.R. 2005. A Marketing Strategy for Independent Schools. MEd Dissertation, University of Johannesburg.
- Oplatka, I. and Hemsley-Brown, J. 2004. The Research on School Marketing: Current issues and future directions. *Journal of Educational Administration*, 42(3):375-397.
- Pallant, J. 2013. SPSS survival manual. 5th Edition. McGraw-Hill Education, England.
- Read, C & Bick, G. 2014. A comparison of the marketing of independent schools in South Africa and the United Kingdom. *International Journal of teaching and Education*, 2(1): 18-37.
- Sferle, S., Gârdan, D.A., Gudei, S.C. and Geangu, I.P. 2012. Implementation of marketing principles – a necessity in primary school education. *Contemporary Reading in Law and Social Justice*, 4(2): 764-773.
- Smith, L. 2015. Marketing of Curro Krugersdorp [personal interview]. 9 March. Krugersdorp.
- Soedijati, E.K. and Pratminingsih, S.A. 2011. The impacts of marketing mix on student's choice of university. Conference proceedings of the 2nd International conference on Business and Economic research. Conducted by Universitas Widyatama, Indonesia.
- South African Social Media Landscape 2015. Executive Summary. Available: <http://www.worldwideworx.com> (accessed 25 May 2015).
- The South African Schools Collection. 2010. Cape Town: Picasso Headlines.
- Thomas, T. 2015. Shareholders approved AdvTech's acquisition of Maravest Schools. Press Release. Available: <http://www.advtech.co.za> (29 April 2015).

Van Tonder, E. and Ehlers, L. 2011. Factors threatening the survival of independent financial advisers in their organisational life cycle: An exploratory study. *South African Journal of Economic and Management Sciences*, 14(2):155-169.

Van Wyk, A. and Bisschoff, C. 2012. 'n Meetinstrument om die beeld van 'n sekondêre skool te bepaal. *Tydskrif vir Geesteswetenskappe*, 52(3):415-432.

Vigar-Ellis, D. (2013). Boys' boarding school management: understanding the choice criteria of parents. *South African Journal of Education*, 33(1): 1-15.

DEVELOPMENTAL CHALLENGES FACED BY THE ZIMBABWEAN ECONOMY: THE LINK TO THE ECONOMY STRUCTURES

Genius Katekwe
University of Venda, South Africa

ABSTRACT

Sub-Saharan Africa (SSA) holds the largest proportion of the world's precious resources' deposits. However, numerous country studies bemoan the lack of policies in SSA that can transform its natural resources into industrial development. This paper focuses on the Zimbabwean case, a low-income country characterised by political instability and conflict as well as economic decline (International Monetary Fund (IMF), 2014). After independence in 1980, the Zimbabwean economy realised a notable upward trend. It is believed that this economic growth can be attributable to the prospects of democracy and majority-rule. Given the strategic importance of the agricultural sector, the government failed to be fully supportive of agriculture to ensure continued economic viability. A closer inspection reveals that the Zimbabwean government did not prioritise this sector at a policy level. This purpose of this paper is to discuss the developmental challenges faced by the Zimbabwean economy. To present this argument, the paper addresses three issues. First, it outlines the several risks that emanated from these challenges. Second, the paper establishes a link between the structure of the economy and some identified developmental challenges. Third, an explanation on how the identified challenges help to create a peculiar risk pattern in the economy will be provided. The paper concludes by proposing some practical solutions that may resolve these challenges.

Keywords: Challenges, development, economy, government.

INTRODUCTION

Sub-Saharan Africa (SSA) holds the largest proportion of the world's precious resources' deposits. However, numerous country studies bemoan the lack of policies in SSA that can transform its natural resources into industrial development (Page, 2014). While this problem is widespread in Africa, this paper focuses on the Zimbabwean case.

Zimbabwe is a low-income country characterised by political instability and conflict as well as economic decline (International Monetary Fund (IMF), 2014). This negative spiral in the economy has resulted in numerous investors' side-lining trade with Zimbabwe (Page, 2014). The Zimbabwean economy, however, was not always in the doldrums. For instance, soon after attaining its independence in 1980, the Zimbabwean economy realised a notable upward trend. It is believed that this economic growth can be attributable to the prospects of democracy and majority-rule.

The Zimbabwean economy is generally agro-based. As said by Maiyaki (2010), agriculture is the backbone of the Zimbabwean economy and accounted for 18percent of the Gross Domestic Product (GDP) in 2005. As previously noted, Zimbabwe is an example of an economy that has failed to transform its abundant natural (i.e., agricultural) resources into economic development. To illustrate, given the strategic importance of the agricultural sector, the government failed to be fully supportive of agriculture to ensure continued economic viability. Closer inspection reveals that the Zimbabwean government did not prioritise this sector at a policy level. Consequently, much of the agricultural resources were dilapidated; resulting in the economy being reduced to a "begging basket", an economy that was once revered as the bread basket of Africa.

The purpose of this paper is to discuss the developmental challenges faced by the Zimbabwean economy. To present this argument, the paper addresses three issues. First, it outlines the several risks that emanated from these challenges. Second, the paper establishes a link between the structure of the economy and some identified developmental challenges. Third, an explanation on how the identified challenges help to create a peculiar risk pattern in the economy will be provided. Lastly, the paper concludes by proposing some practical solutions that may resolve these challenges.

DEVELOPMENTAL CHALLENGES FACED BY THE ZIMBABWEAN ECONOMY: THE LINK TO ECONOMIC STRUCTURES

Corruption

Corruption is the abuse of entrusted power for private gain. Corruption can be classified as grand, petty and political, depending on the amount of money lost and the sector where it occurs. (Transparent International, 2016). Corruption has become one of the biggest impediments to development because those entrusted with power only focus on their private gain rather than the collective benefit for all citizens.

There are numerous examples in Zimbabwe where corruption has continued to marginalise the ordinary citizens and hence undermining development (Hove, Nyamunda & Mukwambo, 2014:72). The gap between the wealthy elite and the poor (the have not) continues to grow. People expected to benefit from one of the Indigenisation and Empowerment Act (hereafter called “Act”) (Republic of Zimbabwe, 2008) that was gazetted by the government. Those entrusted with power, abused the Act for their own personal benefit. This Act requires a lot of revisions in the manner in which it is being implemented if the ordinary people of Zimbabwe are to benefit. The government had an objective to push for radical economic transformation by empowering ordinary black Zimbabweans. However, only those related to individuals in power or support certain political parties ended up benefiting (Shumba, 2014).

From 2006 to 2009, there was a diamond rush in Marange in Eastern Zimbabwe. Thousands of Marange residents were displaced to pave way for the mining of the gems. Community Ownership Trust Schemes were established to empower and benefit the local people in that area. However, due to corrupt activities those in power (especially in the Ministry of Mines and the Mineral Marketing Corporation of Zimbabwe (MMCZ)) amassed a lot of wealth depriving those who were dispersed to pave way for the diamond operations. Consequently because of corrupt activities the diamonds in Zimbabwe’s Chiadzwa area resulted in gross human rights abuses, punctuated by loss of human life, displacements during and after the government’s direct involvement. (Hove *et al*, 2014)

As said by José Ugaz (2016), Chair of Transparency International. “In too many countries, people are deprived of their most basic needs and go to bed hungry every night because of corruption, while the powerful and corrupt enjoy lavish lifestyles with impunity.” Zimbabwe was ranked 154 out of 176 countries with a score of 22 out of 100 on the Corruption Perceptions Index 2016. The score indicates the perceived level of public sector corruption on a scale of 0 (highly corrupt) to 100 (very clean). (Transparent International, 2016).

Transparent International acknowledges that corruption and inequality feed off each other, creating a vicious circle between corruption, unequal distribution of power in society, and unequal distribution of wealth. It is only when corruption has been fought that development can take place that will result in the lives of ordinary Zimbabweans to improve.

Poverty

In Zimbabwe, poverty is also a hindrance to development as the scarce resources that are raised by the State go towards consumption alone excluding the betterment of social services. Currently more than 80percent of government revenues go towards government spending. The resultant factor is that there is no advancement of basic amenities to benefit the citizens and it means that the next generation is being disadvantaged. Currently the greater part of the country's road network system is in a deplorable state because of the unavailability of funds for maintenance or the lack thereof of resources.

As acknowledged by Nnadozie (2003:405) there existed protracted periods where the economic performance of African economies was declining. Population growth rates have been running ahead of real growth rates (*refer to Figure 1*), implying that output per capita has been declining. It was also evident in Zimbabwe that on occasions where there is an increase in population statistics, consumption is highly likely to increase. Ultimately, the need arises for more resources to be allocated to respond to the needs of a burgeoning population. This then led to Zimbabwe to rely on foreign aid rather than mobilising local savings

Figure 1: Zimbabwean Population & GDP Annual growth Rates

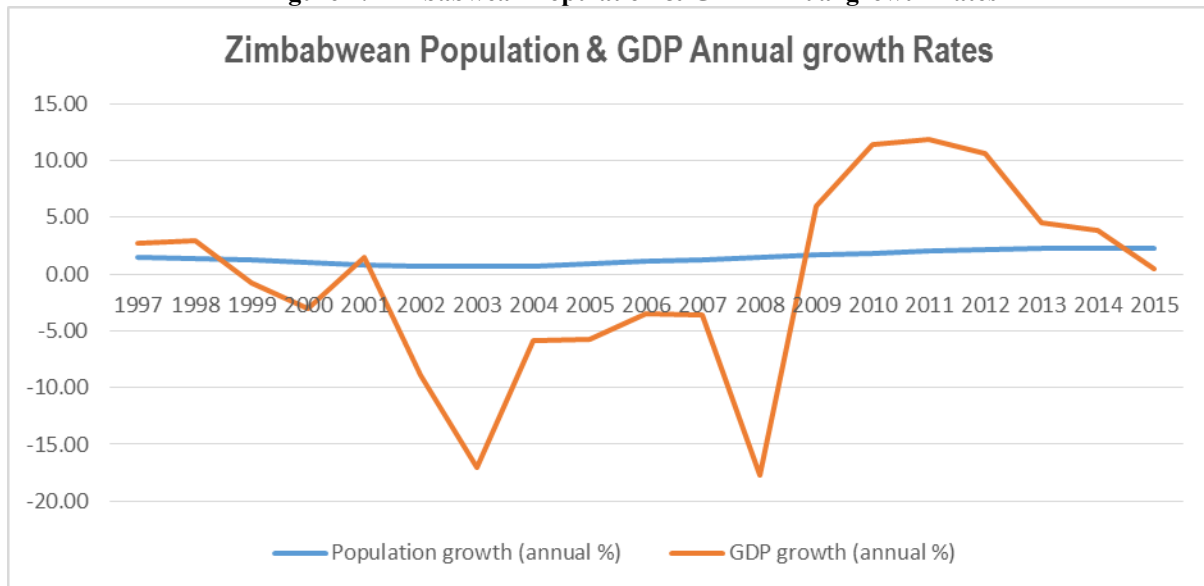

Source: World Bank, Development Indicators, 2016

The reliance of Zimbabwe on foreign aid is a result of the financing gap. The financing gap is the difference between domestic savings and the required investment (Nnadozie, 2003:409). As argued by some economists, foreign aid crowds out export industries, for example, bidding up the price of skilled workers. Aid may make governments dependent on their paymasters in the rich world, not their taxpayers at home (The Economist, 2005). Sanjeev Gupta (2005) of the International Monetary Fund (IMF) once said, "For every extra dollar of aid they are given, governments raise 28 cents less in tax in their local countries." Foreign aid cannot make poverty history; however, it can do harm.

The political and economic crises in Zimbabwe between 2000 and 2008 nearly halved the country's (GDP). The state of being poor increased to more than 72percent, with about 20percent of the Zimbabwean population living in abject poverty. Basic services like the education and public health systems which were once regarded as regional models collapsed. In 2011 the Human Development Index (HDI) was 173 out of 187 countries (World Bank, 2016).

The assistance from donors made it possible for some of the social services to recover. This resulted in the country's HDI ranking to be 155 in the year 2015. Some of the notable changes were in the health and education

systems. The World Bank actually estimated that these changes were more or less at the same levels that the country was at in the nineties. Part of these positive changes was the reduction in HIV prevalence to approximately 15percent from 2014 relative to a level above 40percent in 1998. The maternal mortality rate declined from 960 deaths per 100,000 live births in 2010-2011 to an estimated 614 deaths in 2014; under-five mortality fell from 94 per 1,000 in 2009 to 75 in 2014 (World Bank, 2016). However, with all these notable positive changes noted above, the country failed to achieve a number of the Millennium Development Goals (MDGs) .

The rudimentary for development and poverty reduction is strong should Zimbabwe tackle its political fragilities and begin the journey of building strong and reliable policies that may attract and boost investors' confidence in which the country is doing its business. Policy makers need to prioritise policies that attract and not scare away investors.

Ineffective policies, poor governance and mismanagement (of the economy?)

Effective and efficient good governance is a paramount key ingredient to the development of an economy. Governance refers to a process by which institutions are run and directed. Good governance appears not to exist in most sectors of the Zimbabwean economy and this has a negative impact on the development of the economy. In particular, the public sector or State Owned Enterprises (SOE), Municipalities etc. tend to misplace their objectives. Those charged with governance tend to benefit rather than the ordinary people. Instead of channeling the meagre resources to development, resources are used to buy executive vehicles and improving their livelihoods by increasing executive remuneration.

The challenge in Zimbabwe is that poor governance is initiated by those charged with governance. There is need for public policy management so that the allocation of public resources is transparent and that those charged with governance are able to account for their actions.

External debt burden and capital flight

Another challenge facing Zimbabwe is its external debt burden. A huge external debt burden is a major constraint to growth not only to Zimbabwe but to a majority of SSA countries. This unsustainable debt problem for a majority of African countries persists despite almost 20 years of debt relief efforts from bilateral aid donors and other funders (The African Capacity Building Foundation (ACBF), 2002:12). The external debt burden has also caused the Zimbabwe's credit rating to collapse and as the resultant factor was the disappearance of loans from abroad (Robertson, 2010:7).

Zimbabwe's external debt is estimated at 76 percent of Gross Domestic Product (GDP). Both public and external debt ratios remain at high levels with most of the external debt in arrears. After a debt reconciliation exercise for end 2014 and 2015, the country's total public and publicly guaranteed (PPG) external debt was estimated at about 49 percent of GDP (US\$6.96 billion)¹, 79 percent of which is in arrears (International Monetary Fund (IMF), 2016)

The external debt burden almost cuts across the entire economy. This level of debt burden continues to mount pressure on authorities and it crowds out any possibility of borrowing to fund development. This is one of the reason why most of the country's development projects are stalling. The country is heavily indebted. The following are some of the risk patterns that have emanated from this burden of a growing external debt;

- Stalling of government developmental projects because of lack of funding;
- Inability of the State to attract funders because the country is classified to have a risk of default;
- Exponential increase in road carnage because of a poor road network. Roads not being maintained because of lack of funding; and
- Under developed economy because investors don't feel safe to inject capital because of poor debt management policies

One of the practical solutions to mitigate or resolve the increasing external debt from a development finance perspective is for Zimbabwe to pursue stringent, viable measures that respect the lenders (financiers) debt covenants. The IMF in 2016 acknowledged that with the clearing of arrears to the International Financial Institutions (IFIs), the result is that this will unlock concessional financing, the country's debt burden would only marginally improve, requiring the need for the country to follow sound economic policies.

¹ Equivalent of R82.6 billion using average exchange rate for 2014 and 2015 of US\$1 to R11.87.

Some economists have even argued that capital flight is a result of heavily indebted countries' or inability to recover from debt problems (Makochekeanwa, 2007). The absence of capital in Zimbabwe has continued to affect meaningful development. Makochekeanwa (2007) estimated that the Zimbabwean capital flight stood at US \$10.1 billion over the 1980 to 2005 period, with capital flight-to-GDP ratio roughly 5.4 per cent. Simply put, for every US dollar of GDP accumulated by Zimbabwe annually from 1980 to 2005, private Zimbabwean residents accumulated (US) 5.4 cents of external assets annually during the same period. However, should better management policies for Foreign Direct Investment (FDI) transactions be put in place, it may prevent leakages of the same to leave the country.

Exodus of skills and experience (human capital flight)

Human capital flight is one of the major developmental challenges in Zimbabwe. The country lost thousands of talented individuals who are crucial to the development of the economy. The loss of trained and highly skilled Zimbabweans to developed countries has continued to hamper development in private and public sector economic structures. Human capital is not only central to the development of the Zimbabwean economy but also to the present development age in which knowledge and brain power gives the country a competitive age (ACBF, 2002).

The human capital flight continues to hamper losses in capacity which is attributed to socio-economic instability, inappropriate economic policies and poor infrastructure (ACBF, 2002). The experience of Zimbabwean companies has been severe, most of the people that left were the highest paid in these companies and the most experienced. The exodus of these experienced professionals also negatively affected the tax revenue base of the Zimbabwe government and not only the resident organisations (employers) (Scientific and Industrial Research and Development Centre (SIRDC), 2002). The country survey by African Development Bank Group (AfDB) (2013) estimated that over three million individuals migrated from Zimbabwe between 2006 and 2008. The brain drain further exacerbated the pressure on the dwindling tax revenue base that support the country budget.

The following are some of the risk patterns that have emanated as a result of this great exodus of the skilled and the experienced:

- Very minimal research and development is taking place in the country (about 0.2 percent of the Gross National Product is invested in research and development). This affects innovation in new technologies that support development. Experienced researchers left Zimbabwe in search for other nations that offer better working conditions ("greener pastures") including job security to support their families; and
- The country's tax revenue base continues to shrink because of the emigration of educated individuals. Shrinking of government funding will definitely result in reduced country resources needed for development.

To mitigate brain drain, the government should put in place policies that discourage emigration ("push factors"). However, these policies need to be favourable to citizens for example meaningful rewards as salaries and benefits. SIRDC, (2002) emphasised the necessity for the government to reward workers appropriately (market related benefits) to encourage staying in the country attractive. Expertise and knowledge possessed by people (the measure of economic value for an employee's skills) is the cornerstone to a country's meaningful and sustainable economic development. (Chimboza, 2012).

Five Phases of the Zimbabwe Brain Drain Problem			
Table 1. Zimbabwe's Five Phases of Migration			
Period	Nature of Migrants	Size of migrants based on Main Secondary Sources	Destinations
Phase 1			
1960 – 1979 [^]	Migration of political exiles and employment seekers to South Africa	Approx. 210 000 political exiles, Approx. employment seeking to South Africa	Botswana, Mozambique, South Africa, United Kingdom, Zambia
Phase 2			
1972 - 1989	Flight of white Zimbabweans	Approx. 142 000	Australia, Canada, New Zealand, South Africa, UK, USA,
Phase 3			
1982 - 1987	Ndebele migration	Approx. 5000	Botswana, South Africa, UK
Phase 4			
1990 - 1998	Migration of skilled professionals	Approx. 200 000	Australia, Botswana, South Africa, UK, USA
Phase 5			
1999 – Date	Mass exodus following political and economic crises	Approx. 3-4 million	Australia, Botswana, Canada, New Zealand, South Africa, UK, USA
[^] Flight commenced when the war of liberation escalated in 1972			
source (Pasura, 2008)			

PRACTICAL SOLUTIONS TO RESOLVING THE DEVELOPMENTAL CHALLENGES WITH EMPHASIS ON A DEVELOPMENT FINANCE PERSPECTIVE

The country's revenue collection system is not robust and as result there is a lot of revenue leakages. There is need for strong punitive measures for the evasion of tax especially in the mining sector where policy makers have actually identified falsification by some mining companies when they submit their returns. Policy makers need to demonstrate respect for the rule of law and not condone corruption irrespective of political affiliation. The suspension of the Zimbabwe Revenue Authority (ZIMRA) Commissioner General in 2016 because of engaging in fraudulent activities is a good example of not condoning corruption by policy makers. A robust revenue collection system will definitely improve domestic savings. These domestic savings may in turn be channelled to development and probable repayment of some of the country's external debts. The countries borders are very porous and infiltrated with corrupt individuals. As a result, Zimbabwe loses millions of dollars from goods not declared and smuggled into the country.

There is need to liberalise some of the Indigenous Empowerment Act regulations so as to attract new capital preferably in form of equity rather than loans. The policy makers need to address challenges with regards to access to financing, policy instability and inadequate supply of infrastructure. The later will indicate the seriousness of the country about investment policies and the quest for real development. The importation of second hand vehicles especially from Japan must be strictly regulated so as to protect the local car manufacturing industry. However, this must be preceded by the local car manufacturing industry being in a position to produce the right products at the right quality before strict measures can be put on the importation of second hand vehicles. The manufacturing of local vehicles should meet the consumer demands To initiate policy drafting, the age (year of

manufacture of the vehicle) for imported vehicle can be used to regulate importation. For example allowing importation of vehicles not older than 10 years.

Zimbabwe must devise its own poverty alleviation mechanisms in wide consultation with the civil society before inviting donors to support the plan. The closure of companies because of the increase in operating expenditure has resulted in a significant increase in the informal trading by citizens. There is a greater need for support of these informal, small and micro enterprises through Development Financial Institutions (DFIs) and Venture Capital Institutions (VCIs). DFIs or VCIs maybe in a position to bridge the financing gap by taking some of the risks that the traditional commercial banks may not be willing take as depicted by the diagram in Figure 2, below.

Figure 2: Development Finance “Niche”

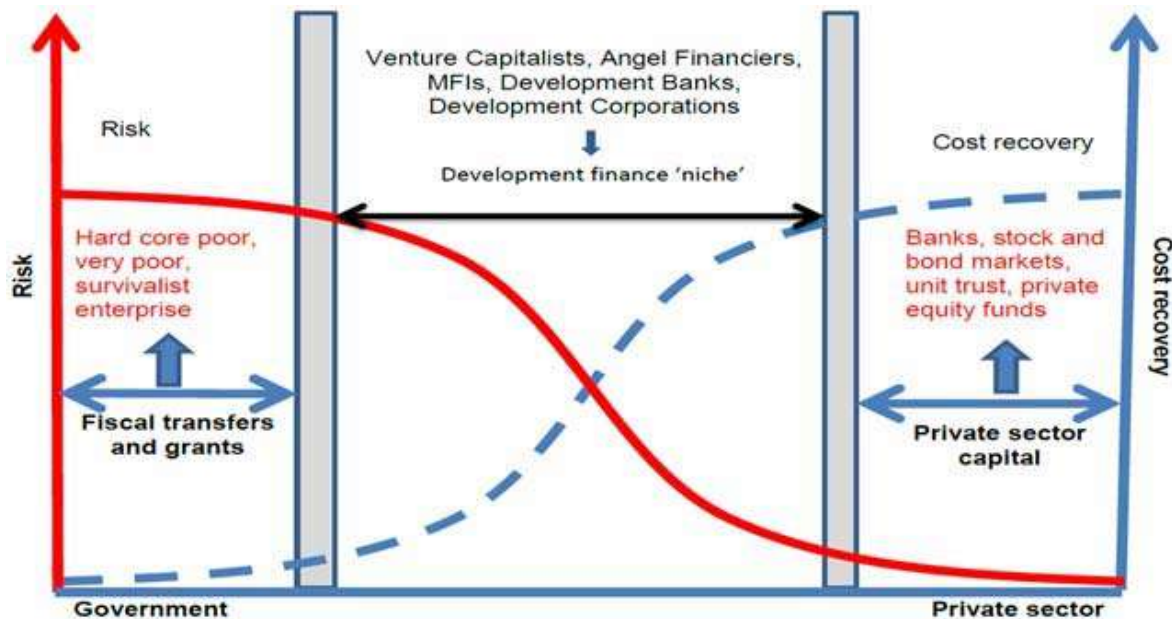

source:(<http://www.financialgazette.co.zw/unpacking-the-role-of-development-finance-institutions/>)

DFIs normally assists in addressing market failure in capital markets. Examples of DFIs and some intervention programmes include inter alia venture capitalists, development banks, industrial development corporations, and credit guarantee schemes. In the United States of America venture capitalists have been the driving force for many years in assisting exponential growth for a number of firms. Some examples of these firms are Microsoft and Oracle which are companies that were incorporated some years ago and have become forces to reckon with in the technology landscape (Afrasia Kingdom, 2014).

The country has a generous endowment of natural resources for example, arable land. After the controversial Land Redistribution Programme around the year 2000, food production declined significantly because of the lack of expertise from the new farmers. However, the country also experienced drought during the same period. There is need for capacity building for the new farmers and support financially. The current government programme termed Command Agriculture, where the government is providing inputs may go a long if implemented and monitored properly.

Policy makers need to implement the agreed measures with creditors to reduce the burden of a ballooning external debt rather than reneging. Reneging on promises as agreed with creditors will negatively affect the country. In the nineties, the World Bank proposed a programme of trade liberalisation measures aimed at reducing the country’s budget deficit. In the following year, during the country’s budget speech, plans that were contrary to the

agreed measures were announced by the government. This announcement plunged the country into a downward trend (Robertson, 2010:6).

The national budget should prioritise the development of essential social services inter alia public health and education. In the previous fiscal years more than 90percent of budgeted resources in Zimbabwe are mainly channelled to consumption (payment of salaries and allowances) rather than development. This is one of the reasons why the country's education system which was once a model for Africa has seriously deteriorated. Once there is no development especially in the education sector, it may also mean that economic development has been affected because of a possible shortage of professionals that are supposed to come through the education system.

CONCLUSION

Zimbabwe's developmental challenges are however not insurmountable. The country possesses numerous resources which policy makers should take advantage of to benefit all the Zimbabweans. Experienced professionals should be attracted back into the country to assist in the rebuilding of the economy. To take advantage of her resources and to realise her potential, Zimbabwe requires prompt action to correct fiscal policies, re-stabilize the monetary system, and resolve arrears to the international funders which would probably allow for a resumption of development financing. It will also require the continued renewal of institutional and operational capacity in the public sector as well as deep reforms in the investment climate (World Bank, 2016)

It is of paramount importance that the policy makers prioritize the eradication of rampant corruption especially in the public sector entities. Perpetrators of corruption must be brought to book without fear or favour so as to send a strong message that anyone convicted of this crime will face serious penalties. A good example is what the current President of Tanzania (Dr John Magufuli) is currently implementing to combat corruption in his country. Some executives at Muhimbili National hospital were fired unexpectedly because they were failing to implement correct measures to the proper functioning of the hospital. The focus of the government must be to provide basic essential public services. Unnecessary government expenditure must be cut and those resources should then be diverted to essential public services.

REFERENCES

- Afrasia Kingdom. (2014) <http://www.financialgazette.co.zw/unpacking-the-role-of-development-finance-institutions/>(accessed 13 April 2017)
- African Development Bank Group (AfDB),(2013).*Zimbabwe Country brief 2013-2015*
- Chimboza, A.2012. *From Brain Drain to Brain Gain: Addressing Human Capital Needs for Post Crisis Zimbabwe's Capacity Building*
- Hove, M., Nyamunda, T., & Mukwambo, P.(2014).*Violent state operations at Chiadzwa (Zimbabwe) diamond fields 2006-2009.Journal of Aggression, Conflict and Peace Research Vol NO.1,2014, pp. 56-75*
- International Monetary Fund (IMF), (2016). *Staff Report for the 2016 Article IV Consultation and the third review of the Staff monitored program – Debt Sustainability Analysis.*
- International Monetary Fund, (2014).*Proposed Grouping on WEO Country Classifications: Low Income Developing Countries.*
- Maiyaki, A (2010).*Zimbabwe's agricultural industry. African Journal of Business Management Vol. 4(19), pp. 4159-4166.*
- Makochekanwa, A. (2007).*An Empirical Investigation of Capital Flight from Zimbabwe*
- Nnadozie, E. (2003).*Africa Economic Development. Emerald Group Publishing*
- Page, J. (2014).*Africa's Failure to Industrialise: Bad Luck or Bad Policy*
- Pasura, D.M. (2008), *A Fractured Diaspora: Strategies and Identities among Zimbabweans in Britain. Unpublished PhD thesis, University of Warwick*
- Robertson, J. (2010).*Zimbabwe: The challenges facing the Restoration of Economic Stability and Growth.*
- Scientific and Industrial Research and Development Centre (SIRDC), (2002).*An Analysis of the Cause and Effect of the Brain Drain in Zimbabwe*
- Shumba, B.M. (2014). *An Evaluation of Indigenisation Policy in Zimbabwe. Unpublished A dissertation submitted in fulfilment of the requirements for the degree of Master of Social Science in the School of Social Sciences at the University of Kwazulu-Natal*
- The African Capacity Building Foundation (ACBF), (2002).*Major Development Challenges & Their Capacity Building Dimensions*
- The Economist, (2005) *Helping Africa help itself :<http://www.economist.com/node/4129031>(accessed 12 April 2017)*
- Transparent International, (2016).*Corruption Perceptions Index.*
- World Bank, (2016) <http://www.worldbank.org/en/country/zimbabwe/overview> (accessed 13 April 2017)

OIL BUSINESS JOINT VENTURES PERFORMANCE MANAGEMENT DETERMINANTS – TOWARDS A CONCEPTUAL FRAMEWORK

Khaled Kesseba
Sheffield Hallam University, UK

ABSTRACT

Production sharing contracts (PSC) are a pervasive fact of economic life in developing countries. They involve a government-contractor relationship with the aim of exploring, developing and producing oil within a Joint Venture environment. This public-private partnership form of collaboration often entails conflict in managing the Joint Venture because of the different strategic objectives between its partners. The rights of the host government and the obligations on the foreign contractor are central in a PSC. This proposes numerous complexities and dilemmas in managing the Joint Venture. Joint Ventures although being an increasingly common direction of corporate strategy over the past two decades, have accentuated the problem of measuring the business performance. Joint Ventures performance determinants are problematic in the sense that both parties find it difficult to distinguish between bad luck and poor performance. The major difficulty in managing the performance of a Joint Venture lies in the confusion of how to identify and measure the performance. The controversy often stems from the lack of clarity of what a determinant of performance is. The development of key performance factors and indicators receives a considerable attention as being a powerful management tool. This study will present a conceptual framework of the performance management determinants of non-equity petroleum Joint Ventures under a PSC contractual agreement. The proposed conceptual framework will contribute to the academic knowledge in managing non-equity petroleum Joint Ventures, as well as the contribution to management practitioners in managing oil business within the oil production sharing contract system.

Keywords: Joint Ventures, Non-equity Joint Ventures, Performance management determinants, Petroleum Industry.

INTRODUCTION

Production sharing contracts (PSC), as one of the types of petroleum business contracts, is widely used to establish a Joint Venture between one or more partners on one side, and the host country government on the other side. The aim of the Joint Venture is exploring and developing oil and energy. The host government rights are significantly higher compared to the investor or the partner (Johnston, 1994; Pongsiri 2004). Governments prefer the non-equity contractual Joint Ventures to maintain its control over the business operations for that important and strategic source of income and to keep its sovereignty on its natural wealth (Al-Emadi, 2010).

The petroleum Joint Ventures are different from Joint Ventures between the same industry partners where it's commonly referred to as "government participation" to reflect a government-contractor relationship (Johnston, 1994). Various business studies in the literature refers to this type of partnership as a contractual agreement and they would subtly refer to it as a non-equity alliance (Pan and Tse, 2000). However, it could be argued that those types of contractual agreements are still Joint Ventures but from the non-equity side of it. The term Joint Venture was developed to name a business concept and not a legal one, that is to cater business purposes when a group of domestic companies combined their skills, resources and operations to run a potential profitable market (Al-Emadi, 2010). Al-Emadi (2010 p.646) argues that researchers are divided over the legality of the Joint Venture definition and concluded that "Joint Venture" is an ambiguous term.

This paper develops a conceptual framework to address the identification of performance management determinants in the petroleum non-equity Joint Venture under such an agreement (PSC). The appropriate management of performance is expected to demonstrate proper future business strategic choices (Vaidya, 2009, Micheli and Manzoni, 2010). Joint Ventures have been increasingly a common aspect of corporate strategy to different international industries, however the performance record of Joint Ventures have been problematic (Glaister, 2004). Accordingly, the paper will discuss briefly the (1) Joint Ventures importance, then (2) shed the light on the differences between equity and non-equity Joint Ventures, then (3) discuss the non-equity petroleum Joint Ventures background in order to lead the discussion about (4) performance management in relation to the non-equity Joint Ventures, and the proposed performance management conceptual framework.

JOINT VENTURES

Joint Ventures as an organizational form of business are growing in numbers attracting foreign capital and investments (Marjit et al., 1995); They have been, and still are, the optimal business mode of foreign direct investment in developing countries. That is evident by the record of eighty percent in some less developed countries and the rapid growth of Joint Ventures in the last three decades has been well documented (Beamish and Banks, 1987; Purkayastha, 1993; Gulait et al, 1994; Beamish and Delois 1997; Styles and Hearsh 2005).

The importance of choosing Joint Ventures rather than other entry modes of business is subject to the diseconomies of acquisition. Diseconomies of acquisition refer to the mitigation of higher costs of internal development or managing unrelated activities (Kogut, 1988). The idea of diseconomies of acquisition is based on transaction cost theory which is founded on cost minimization and the implications of the control rights over transaction costs when conducting business in imperfect markets (Williamson, 1975, 1985; Beamish and Banks, 1987; Bai et al., 2004). Other aspects of Joint Ventures importance are related to the increase of the global environment of an organization or a company by expanding its business in new international markets. They reduce political risk between countries by allaying and defusing xenophobic reactions. And are used as devices to exchange or pool knowledge helping countries and businesses growing their experience and ability to maximize their wealth and profit (Kogut, 1988, Hennart, 1995).

The partners' strategic behavior in a Joint Venture is one of the important factors to the choice of Joint Ventures as a business mode, whether the underlying form of Joint Ventures achieves the firm's competitive position which affects its profitability and the firm's influence and control over its asset value (Kogut, 1988, Hennart, 1995). The need for local partner may arise due to several reasons. Beamish (1994 p. 65) has categorised the need of a local partner into: (1) Items readily capitalised: capital and raw materials, (2) Human resources needs: labour, (3) Market access needs: using the local partner experience, (4) Government needs: regulations, (5) knowledge needs: local knowledge. The organizational learning theory states that Joint Ventures are encouraged when (1) both firms desire to acquire the other's know-how and also (2) when one firm wishes to maintain its own knowledge while pertaining and benefiting from the other partners' current knowledge or resources (Kogut, 1988, Glaister, 2004).

The concept of cultivating a business within Joint Ventures arrangement has been refuted by the internalization theory of the multinational enterprises. Beamish and Banks (1987) argues that Joint Ventures are considered an inferior choice to wholly owned subsidiaries which offers a better business option than Joint Ventures as the firm would establish its own branch of operations, and accordingly have a stronger economic incentive allowing higher returns available on its ownership-specific advantages (Beamish and Banks, 1987). Arguably, the focus of this paper is on non-equity Joint Ventures in the petroleum sector in developing countries. This business is not accessible for investors through the option of wholly owned subsidiaries due to the political, economic, and legal systems of the host countries using petroleum production sharing contracts. Al-Emadi (2010, p. 646) argues that the historical struggle of the host states in their search for a new type of Joint Venture partnership with foreign companies is related to the factors of the advancement of technology and knowledge, the state of the economy, and the maturity of the political and legal system of those host states. In addition to the increased bargaining power of

oil-producing states through the establishment of Organization of Petroleum Exporting Countries (OPEC) and the United Nations (UN) resolutions on permanent sovereignty over natural resources (Al-Emadi, 2010).

Hereby Joint Ventures are an important source of FDI, and are the predominant of business by the force of the legal framework of developing countries. Also, investors or companies will be involved in a partnership agreement for large-scale or high-risk ventures in order to diversify and generate profit by accessing or obtaining scarce resources as one of the internal and strategic motives of a Joint Venture entry mode choice (Harriagin, 1985; Vaidya, 2009). Notably that the Joint Ventures between industry partners differs from the government-contractor relationship (Johnston, 1994). In the petroleum business, the state-owned holding company is one of the partners, and the other partner is the investor, the government intervention is commonly referred to as “government participation” (Kogut, 1988; Johnston, 1994, Vaidya, 2009, Al-Emadi, 2010).

EQUITY AND NON-EQUITY JOINT VENTURES

Generally, equity Joint Ventures arise whenever partners bring together given assets and are expected to embrace capital commitments to the Joint Venture, consequently partners are paid at the end of a given period according to their contribution from the profits earned by the entity. The foreign direct investment (FDI) in equity Joint Ventures is directed to minimize transactional costs by pursuing raw materials or components, pooling knowledge, distribution of costs, or loan capital for major projects. (Kogut, 1988; Hennart, 1995). However, in a non-equity based Joint Venture partners are not required to be involved in future decision making beyond the life of the project or the contract. They involve contractual agreements where the key dimension of the Joint Venture is the exchange of performance within a stipulated contract. Non-equity Joint Ventures usually cover a wide array of contractual agreements. Those agreements form a strategic alliance where contracts provide incentives within underlying contingencies and complexities. Both parties share the residual value of the venture without identifying the performance requirements (Kogut, 1988; Zahra and Elhagrasy 1994; Hennart, 1995).

When forming a Joint Venture, negotiators tend to work out an agreement between the prospective partners with the aim to control future contingencies to the extent where they can be visualized (Parkhe, 1993; Contractor and Reuer, 2014). And regardless of their governance structure, the legally drawn up agreement for organizing the joint relationship between partners, would not clearly provide a clear differentiation whether it is an equity or non-equity based Joint Ventures (Vaidya 2009; Contractor and Reuer, 2014). The field has been overly restricted to the generic categorization of international strategic alliances and collaborations such as relational or contractual, equity or non-equity, without probing the specifics of the agreement structure of international alliances or Joint Ventures. Leaving the field without a profound detailed dissection of the anomalies or commonalities between its distinct types. (Schilling, 2009).

Additionally, from the reviewed literature, scant attention has been given to the ex-ante details of agreements to identify the difference between the Joint Ventures types, compared to the post formation and governance of a Joint Venture and how it is managed between its partners. Some studies have addressed the agreement details of the contingency planning, specific controls, monitoring, cooperation and coordination mechanisms (Argyres et al., 2007; Faems et al., 2008; Lumineau and Malhotra, 2011). Other studies covered contractual provisions regarding the divisions of decision making between each partner within a Joint Venture, the procedures of making these decisions, and the ways of resolving disagreements or conflicts (Reuer and Ariño, 2007; Robinson and Stuart, 2007; Ryall and Sampson, 2009; Adegbesan and Higgins, 2010; Lumineau and Malhotra, 2011; Ariño et al., 2014)

In sum, most studies haven't exposed a clear distinction between equity and non-equity based Joint Ventures. Accordingly, the following three sections discuss the difference by highlighting numerous factors affecting the potential choice between equity and non-equity Joint Ventures. Those factors are discussed from the governance structure perspective, whether that entails partners' opportunistic behavior, partners' relationships, knowledge transfer, or the distance between the partners' location.

The potential opportunistic behavior between partners.

Originally, the formation of a Joint Venture as a strategic alliance is grounded on the transaction cost theory. Within that theory, the threat of opportunism is affected by the characteristics of the transaction, the partner, and the relationship (Contractor and Reuer, 2014). However, there is a distinction between the consequences and the likelihood of opportunism. Contractor and Ra (2002), Woolthuis et al. (2005), and Shah and Swaminathan (2008) argue that the problem of the consequences of opportunism lies within its impact on the firm's business goals within the Joint Venture. If the consequences are of high impact, then it could be considered a severe one. However, if the partner is not capable to behave opportunistically or is a trustworthy partner, then opportunism is of less consequence. However, both confidence and trust will negate or minimize the perceived risk of opportunism (Lui and Ngo 2004). Arguably, confidence and trust are not enough if there is no stipulation of an adequate control in place. Therefore, firms have to deal risks that arise from both potentially opportunistic partners and /or uncertain institutional and legal environments (Williamson, 1985; Geringer and Hebert, 1991; Parkhe, 1993; Parkhe, 1998).

In a non-equity or contractual Joint Venture environment, contractual safeguards are a crucial component in strategic alliances business. Opportunism can be curbed through the reduction of monitoring cost by increasing partners' relationship transparency, and by strictly clarifying in contracts the business objects and purview, or by using a pay-off structure with stipulated penalties for opportunistic behaviors (Parkhe, 1993; Reuer and Ariño, 2002). However, non-equity Joint Ventures have weaker control mechanisms than equity Joint Ventures (Poppo and Zenger, 2002). Firms under equity Joint Venture usually obtains more alignment of incentives through equity ownership leading to more administrative monitor and control rights rather than non-equity Joint Ventures (Pisano, 1989; Oxley 1997; Reuer and Ariño, 2007).

Another aspect from the control angle, which mitigates opportunism, is the equity Joint Venture board of directors. It has long been considered as an important management tool in the core theories and applied research based on equity ownership rights (Balakrishnan and Koza, 1993; Bamford et al., 2004; Bamford and Ernst, 2005; Hewitt, 2005). Arguably, in non-equity Joint Ventures, contracts stipulate steering committees derived from legal establishments which is attributed similarly as the equity Joint Venture board of directors. However, these steering committees has been also criticized as some in the non-equity Joint Ventures can be more hierarchical than others, and as such there is no fixed form for these committees (Williamson, 1991; Hoetker and Mellewig, 2009; Reuer and Devarakonda, 2014; Contractor and Reuer, 2014)

Knowledge transfer, distance between partners, and partners' relationship and involvement.

From the previous discussion, transaction cost theory and its profound angle of opportunism was the notion of Joint Venture governance structure, probing some insights of the legal or contractual form of the equity and non-equity alliances. However, the formation of the governance structure can also be affected by the partners' relationship and involvement drivers and not only the partners' opportunistic behavior and the need to control it. A recurring criticism of the transaction cost approach that it fails to acknowledge the role of non-transactional or the relational capital attributes in which they significantly influence the choice of Joint Ventures governance mode whether equity or non-equity (Globerman and Neilsin 2007).

Relational capital encompasses trust, respect, and friendship between partners in a business collaboration. Few studies tried to establish a link between the operations of a relational capital alliance to the perceived risks of opportunism, especially with the environmental attributes of the host country, given the legal and regulatory regimes of the alliance location (Thuy and Quang, 2005; Globerman and Neilsin 2007). In partnerships, contractual complexities based on opportunism risk has been suggested to be detrimental as the safeguarding clauses might negatively hurt the partners' relationship, where trust between partners has been a positive indicator for better governance and alliance performance than contract provisions (Dyer and Singh, 1998; Malhotra and Murnighan, 2002; Woolthuis et al., 2005). However, it was proven through studies that the strength of such relationships is not inconsistent with contract complexity, and that some contractual provisions that enhance alliance performance

through communication, and joint work could be categorised positively (Mayer and Argyres, 2004; Weber and Mayer, 2011; Ariño et al., 2014).

Partners experience with alliances and their familiarity of the counter-partner enables deep understanding of relevant challenges and contingencies needed to be considered in a Joint Venture, which may allow them to add more contractual details to the governance structure leading to better alliance performance (Kale et al., 2002). It was also found that in more complex and hierarchical alliances, the need for partner's involvement and interaction is highly required, where the process of interaction and intensity of inter-partner involvement is necessary to coordinate operations and to improve efficiency. Accordingly, knowledge can be transferred with the strategic aim to maximize joint synergistic value. (Gulati and Singh 1998, Kale et al., 2000; Contractor et al., 2011). In a relational based strategic alliance with partner's positive involvement and interaction, knowledge and technology transfer are proved to be more efficient (Lee and Cavusgil, 2006; Contractor et al., 2011).

However, in the context of international collaborations, other factors need to be considered. Countries have different legal and institutional foundations; these foundations are classified by foreign investors whether they are strongly or weakly matching their own property rights when taking the decision of investing in those countries. In addition, the decision-making process will take into consideration that monitoring international alliance is more difficult and costly bearing the appropriation hazards within the potential institutional environment. Also, the geographical and cultural distance and difference, thus affecting the quality of information and knowledge transfer flows regardless of the partner's involvement level (Davidson and McFetridge, 1985, Oxley, 1999; Ghemawat 2001; Hagedoorn et al., 2005; Phene et al., 2006).

Accordingly, and based on the country-specific approach, firms tend to use non-equity Joint Ventures with deeper inter-partner involvement in technology based relationships fostering beneficial control and learning atmosphere, rather than equity Joint Ventures, to negate the geographical distance cost. However, under weak property rights protection in the country where the Joint Venture business is based, equity Joint Venture collaboration is preferred given that appropriation hazards are of higher concern regardless of the level of the partners' relationship or involvement (Gulati, 1998; Van Kranenburg et al, 2014).

The Choice between Equity Vs Non-equity based Joint Venture.

Generally, the academic and business wisdom calls for equity based Joint Ventures rather than non-equity Joint Ventures, the reason behind the choice, is to monitor and control potential opportunistic behavior of partners through ownership rights, and to mitigate the property rights hazards, under the conditions of high investment, market risk, and technological uncertainty (Contractor and Reuer 2014). Studies about the deal-specific alliances which involve intrinsic developed technology and assets specificity showed that partner's relational based involvement and commitment is highly required. Occasionally, firms tend to use equity Joint Ventures to ensure that partners are committed and to monitor their interests under the condition of weak property rights environment (Contractor and Ra, 2002; Helm and Kloyer, 2004; Parmigiani and Rivera-Santos, 2011). However, with strong property rights environment non-equity Joint Ventures might be used, as this choice will reduce the geographical monitoring cost. Firms have recently codified or distilled manuals and procedures in which knowledge can be more readily transferred, rather than being resident in the minds of engineers and analysts (Gulati, 1998; Contractor and Lorange, 2002; Van Kranenburg et al, 2014; Contractor and Reuer, 2014).

There are other environmental or institutional variables closely relate to the country or industry context when studying how Joint Ventures operate. Contractor and Reuer (2014) hypothesised that, based on the changes of the global business environment, the choice of a non-equity Joint Ventures could be favoured over the equity Joint Ventures alternative. Expropriation hazards have significantly and recently diminished over the past 20 years specially as agreements in the international strategic alliance context includes arbitration clauses, that serves as a protection of the foreign partner assets and investment value.

As such, no escape of the institutional fact that Joint Ventures in the petroleum industry in developing countries are formed as a non-equity Joint Venture where country legal and institutional differences powerfully

influence the strategic choice of the type of Joint Ventures (Tong et al., 2008, Al-Emadi, 2010). However, despite globalization, firms still tend to form equity Joint Ventures when the property rights or knowledge protection are weaker in the nation or location of the alliance. The lower legal protection and higher expropriation risk, the probabilities of an equity Joint Venture increase over non-equity Joint Venture (Oxley,1999; Delios and Henisz, 2000; Hagedoorn et.al,2005).

NON-EQUITY JOINT VENTURES AND THE PETROLEUM INDUSTRY

The petroleum or the oil and energy sector is strategically important, in the sense of maximizing the economic wealth and welfare of the country through FDI, oil production, and the optimization of the natural and hydrocarbons reserves (Pongsiri, 2004). All Joint Ventures in the petroleum industry under PSC are formed as a non-equity Joint Venture partnership and within that form the investor or the partner in the Joint Venture is mainly seeking profit maximization part of the business (Johnston 1994; Pongsiri 2004). The government or state owned company assigns its representatives in the Joint Venture, the investor also assigns counter representatives via a branch office allowed by the host country. That appointment of representatives of both partners equally constitute the Joint Venture's board of directors or steering committee covering technical operations, financial, and general management areas (Zoubir, 2000; Pongsiri, 2004).

Oil and gas development projects are characterized by large capital investments. Exploration and production operations encompass various activities. The range of activities would be from undertaking geological surveys, identifying hydrocarbon resources, to economically and commercially exploiting them. Companies in this sector are of a high-risk nature in the physical, commercial, and political sense as it is difficult to determine in advance the existence, extent and quality of hydrocarbon resources, as well as production costs and the oil future price in the world market which will be also affected by host country economy considerations (Bindemann, 1999). Owing to difficulties in gaining access to risk capital and lack of expertise needed for resources exploration and development, most developing countries grant development rights to foreign firms which have adequate capital, technology and expertise, including abilities and competences to manage investment risks towards their diversified portfolios (Pongsiri, 2004).

Basically, there are many petroleum fiscal systems that regulates and organize the petroleum and energy business. There are two main families or systems; (1) PSCs and (2) the concessionary systems (Nichols, 2010). Typical development rights can be addressed into a PSC contractual arrangement. The classical form of such agreements is the concessionary system mostly used in the United States and the United Kingdom. The differences between both systems arise from different attitudes towards levels of control granted to companies, compensation and reward-sharing schemes, that includes the level of involvement by governments (Johnston, 1994; Bindemann, 1999).

Specifically, PSCs are widely chosen in developing and transitional economies, mineral resources are owned by the state, similar to the concessionary system. The difference here is that the foreign company as a contractor or investor is invited in to provide technical and financial services for exploration and development operations. The foreign contractor or company usually bear the entire exploration cost risk, and receives a specified share of production as a reward of profit and / or cost recoup for its initial investment and operating expenses which is referred to as "Profit Oil" and "Cost Oil" respectively (Nichols, 2010).

In strong and active Joint Ventures, both parties benefit from co-operation. The aim of the partnership as a relational contract is to ensure that they both bring different strengths to that joint business relationship. That is achieved through utilizing known sources of hydrocarbons in the most economical and effective way (Luo, 2002). However, in PSCs, the rights of the government are superior over the rights of the investor/contractor. It is not surprising that the different objectives of the two partners are most likely to clash (Bindemann, 1999). That often leads to negative outcomes such as loss of interdependent decision-making and information asymmetry. In addition

to cultural and institutional differences, further disagreements resulting from any change in the existing legislation consequently affects Joint Venture cooperation and performance (Mikesell, 1975; Provan 1984; Jacobs, 1992).

PSC in the oil and gas sector, as a pervasive fact of economic life in the petroleum industry Joint Ventures, entails rise of conflict of interest between public and private partners, that conflict might also involve subjective interests. This problem may result in one or both parties undertaking actions that are against the interests of the other contracting partner hindering performance and in turn would impact both parties (Pongsiri, 2004). Joint Ventures break up when partners have different goals, incompatible with one another, or when one or both are renegeing from their promises, and where each partner's managers are unable to work together (Vaidya, 2009).

The appropriate management of business performance is expected to demonstrate the proper future business strategic choices (Vaidya, 2009, Micheli and Manzoni, 2010). Additionally, there are no prescribed models to measure the Joint Venture performance from all aspects, in order to provide and submit enough data to help in decision making proceeds. That is stemmed from the lack of clarity of what drives performance. The development of key performance indicators receives considerable attention given the potential to be a powerful management tool (Ozorhan et al., 2011; Tyagi and Gupta, 2013).

NON-EQUITY JOINT VENTURES PERFORMANCE MANAGEMENT

The management of Joint Venture's performance has been an important research topic for a few decades for different global industries. There is no consensus on an appropriate definition and measurement of Joint Ventures performance, determinants and drivers. The validity of the underlying measures is still questionable, and no attempt has been made to estimate their empirical integrity (Geringer and Hebert, 1991; Arino, 2003; Choi and Beamish 2004; Ren et al., 2009; Ozorhan et al., 2010; Ozorhan et al., 2011). And if researchers could agree on how to conceptualize and measure Joint Venture performance, they are still far from unanimous and a strict consensus about what drives performance (Ren et al., 2009). In addition, there is a major difficulty in evaluating Joint Venture success caused by the confusion of the definition of performance and how to measure it, this controversy stemmed from the lack of clarity about the indicator of performance and what a determinant of performance is? (Ozorhan et al., 2011)

In the conceptualization issue, numerous studies focused on the Joint Venture as an independent entity using the financial output as the ultimate performance indicator (Choi and Beamish, 2004; Dhanaraj et.al, 2004; Lu and Xu, 2006; Luo, 2008; Robins et.al, 2002; Zhang et.al, 2007). Other studies used parents' perspectives only to identify the performance management determinants in a Joint Venture by considering the extent of their satisfaction (Buckley and Glaister, 2002; Ren et al., 2009). Furthermore, various studies have focused on the factors affecting Joint Venture performance, such as survival of the Joint Venture (Dhanaraj and Beamish, 2004; Gaur and Lu, 2007; Kumar, 2005; Lu and Xu, 2006; Makino et.al, 2007;) and the goal achievement factor, using managerial evaluation of the Joint Venture parent's goal achievement (Brouthers and Bamossy, 2006; Child and Yan, 2003; Krishnan et.al, 2006; Luo, 2008; Robson et.al, 2008; Zollo et.al, 2002).

Another recent study addressed the conceptualization issue of Joint Venture performance by grouping them into three perspectives. The perspectives include: (1) Investment-specific factors, covering: ownership distribution, establishment mode, target country uncertainty; (2) Inter-partner relationship specific factors: as management style, control mechanism, commitment and trust, Age of Joint Venture's relationship; and (3) Parent-firm specific factors: Motives of the Joint Venture, FDI and Joint Venture experience, competitive strategy, and parent size (Iarimo and Nguyen, 2015). However, all the mentioned studies were undertaken on equity-based Joint Ventures.

The development of the conceptual framework.

In summary, studies have not reached a consensus or a comprehensive grand theory for Joint Ventures performance management determinants. The reason is stemmed from the angle that different studies were fragmented on distinct factors of performance and carrying out the research approach from different methodological stand points either qualitative or quantitative. In addition to studying the determinants from different viewpoints: ones from the foreign partner's perspective and others from the local partners'. Given the nature of a Joint Venture as a social activity with an economic outcome, it would have different legal, structural and political frameworks within a specific contextual region. Therefore, the structure of the arrangement must be different, and it is recommended to carry on studying those different contexts separately (Hersch and Styles, 2001; Katsioloudes and Isichenko, 2007; Lowen and Pope, 2008; Vaidya, 2009; Bener and Glaister, 2010; Larimo and Nguyen, 2015).

Nippa et al. (2007) describes Joint Ventures as a separate legal organizational entity held by partner firms from different countries, where in that form of partnerships parent firms might have different strategic objectives, and for that reason collaboration may be used as being a tool for selfish ambitions (Stein and Ginevicius, 2010). This paper offers a conceptual framework of non-equity Joint Ventures in the petroleum industry. Ying (1996) suggests that research on Joint Ventures should adopt a multi-perspective approach to consider the dynamic process of Joint Venture management and the influence of not just economic, legal and political factors, but also social and cultural factors. The following conceptual framework is taking into consideration the non-equity Joint Venture management perspective, the inter-partner perspective, the parent to its representative perspective, and the host country perspective along with the industry related conditions.

<u>Managerial Perspective</u>	<u>Operational Perspective</u>		<u>Organisational Perspective</u>
	<u>Inter-partner</u>	<u>Parent-Representatives</u>	
Leadership	Partners' relationship Trust Communication Cooperation Culture Respect Power Opportunism Conflict	JV Management Autonomy Management Stability	Host Country Conditions
Staff Reporting lines			Host Country Environment
Staff development			Industry Environment
			Overall satisfaction on JV
	Partners' Alignment Targets		
	Partners' Qualifications		

DISCUSSIONS AND CONCLUSIONS

This paper has developed a conceptual framework for non-equity Joint Venture's performance management determinants of the petroleum industry in developing countries. The petroleum industry business in these countries is governed by PSCs. That form of a partnership involves a government-contractor (or foreign investor) relationship within the activity of exploring, developing, and producing oil. There are many disagreements between the Joint Venture partners in operating the business, because of the prevalent rights of the host country partner, as well as the different objectives for each partner. To develop this framework, it was important to shed light on the importance of Joint Ventures. The discussion of Joint Venture's governance structures was the door to identify the commonalities

and anomalies between the equity and non-equity based Joint Ventures, the reason behind was to enable the reader understanding the context of the paper relative to non-equity based Joint Ventures.

Identifying how to better manage the performance of that Joint Venture entails conceptualizing the internal and external factors affecting the Joint Venture performance. Most studies have addressed performance management determinants of equity based Joint Venture. And the various conceptualizations in these studies were either focused on parents' overall satisfaction or on the financial output of the Joint Venture. Furthermore, studies have grouped the determinants into Investment-specific factors, Inter-partner relationship specific factors, and parent-firm specific factors to address the conceptualization issue. However, there is a lack of clarity about the indicator of performance and what drives it.

This paper focused on developing the conceptual framework of non-equity petroleum Joint Ventures from the conceptualization angle of the factors affecting the Joint Venture performance. The developed framework was developed to consider not only the economic, legal, and political factors, but also social and cultural factors. It covered three perspectives: (1) the managerial perspective as how both partners' representatives manage the Joint Venture as one entity; (2) the operational perspective considering the inter-partner relationship from one side and the parents-representatives relationship from the other side; and (3) the organizational perspective focusing on host country conditions, environment and the industry conditions. A further study will be performed based on this conceptual framework to identify how to operationalize the framework by using an inductive analytical approach.

REFERENCES

- Adegbesan, J.A., Higgins, M.J. (2010). The Intra-Alliance Division of Value Created through Collaboration. *Strategic Management Journal*, vol 32, Iss: 2, pp. 187–211.
- Al-Emadi, T. (2010). Joint Venture contracts among current negotiated petroleum contracts; A literature review of JVCs development, concepts and elements. *Georgetown Journal of International Law*, vol 1, pp. 645 – 667.
- Argyres, N., Bercovitz, J., Mayer, K. (2007). Complementarity and Evolution of Contractual Provisions: An Empirical Study of Information Technology Services Contracts. *Organization Science*, vol 18, Iss: 1, pp. 3–19.
- Arino, A. (2003). Measures of Strategic Alliance Performance: An Analysis of Construct Validity. *Journal of International Business Studies*, vol 34, Iss: 1, pp. 66–79.
- Arino, A., Reuer, J.J., Mayer, K.J., Jane, J. (2014). Contracts, Negotiation, and Learning: An Examination of Termination Provisions. *Journal of Management Studies*, vol 51, Iss: 3, pp. 379–405.
- Bai, C., Tao, Z., Wu, C. (2004). Revenue Sharing and Control Rights in Team Production: Theories and Evidence from Joint Ventures. *The Rand Journal of Economics*, vol 32, Iss: 2, pp. 277–305.
- Balakrishnan, S., Koza, M.P. (1993). Information asymmetry, Adverse Selection, and Joint Ventures. *Journal of Economic Behaviour and Organisation*, vol 20, Iss: 1, pp. 99–117.
- Bamford, J., Ernst, D., Fubini, D.G. (2004). Launching a World Class Joint Venture. *Harvard Business Review*, vol 82, Iss: 2, pp. 91–100.
- Bamford, J., Ernst, D. (2005). Governing Joint Ventures. *McKinsey Quarterly*, vol 15, pp. 12–16.
- Beamish, P.W., Banks, J. (1987). Equity Joint Ventures and the Theory of the Multinational Enterprise. *Journal of International Business Studies*, vol 18, Iss: 2, pp. 1–16.

- Beamish, P.W. (1994). Joint Ventures in LDCs: Partner Selection and Performance. *Management International Review*, vol 34, Iss: 2, pp. 60–74.
- Beamish, P.W., Delios, A. (1997). The Incidence and Propensity of Alliance Formation, in Cooperative Strategies: Asian Pacific Perspective, Beamish P.W., Killing J.P. ed., New Lexington Press, San Francisco, U.S.
- Bener, M., Glaister, K.W. (2010). Determinants of Performance in International Joint Ventures. *Journal of Strategy and Management*, vol 3, Iss: 3, pp. 188–214.
- Bindemann, K. (1999). Production-sharing Agreements: An Economic Analysis. World Petroleum Market Report 25, Oxford Institute of Energy Studies, Oxford, UK.
- Boatang, A., Glaister, K.W. (2002). Performance of International Joint Ventures: Evidence for West Africa. *International Business Review*, vol 11, pp. 523–541.
- Brouthers, K.D., Bamossy, G. (2006). Post-formation Processes in Eastern and Western European Joint Ventures. *Journal of Management Studies*, vol 43, pp. 203–229.
- Child, J., Yan, Y. (2003) Predicting the Performance of International Joint Ventures: An Investigation in China. *Journal of Management Studies*, vol 40, pp. 283–320.
- Choi, C.B., Beamish, P.W. (2004). Split Management Control and International Joint Venture Performance. *Journal of International Business Studies*, vol 35, Iss: 3, pp. 201–215.
- Contractor, F.J., Lorange, P. (2002). Cooperative Strategies and Alliances. Elsevier, Oxford, UK.
- Contractor, F.J., Ra, W. (2002). How Knowledge Attributes Influence Alliance Governance Choices: A Theory Development Note. *Journal of International Management*, vol 8, Iss: 1, pp. 11-27.
- Contractor, F.J., Woodley, J.A., Piepenbrink, A. (2011). How Tight an Embrace? Choosing the Optimal Degree of Partner Interaction in Alliances Based on Risk, Technology Characteristics, and Agreement Provisions. *Global Strategy Journal*, vol 1, pp. 67-85.
- Contractor, F.J., Reuer, J.J. (2014). Structuring and Governing Alliances: New Directions of Research. *Global Strategy Journal*, vol 4, pp. 241-256.
- Davidson, W.H., McFetridge, D.G. (1985). Key Characteristics in the Choice of International Technology Transfer Mode. *Journal of International Business Studies*, vol 16, Iss: 2, pp. 5-21.
- Delios, A., Henisz, W.I. (2000). Japanese Firms' Investment Strategies in Emerging Economies. *Academy of Management Journal*, vol 43, Iss: 3, pp. 305-323.
- Dhanaraj, C., Beamish, P.W. (2004). Effect of Equity Ownership on the survival of International Joint Ventures. *Strategic Management Journal*, vol 25, pp. 295-305.
- Dhanaraj, C., Lyles, M.A., Steensma, H.K., Tihanyi, L. (2004). Managing Tacit and Explicit Knowledge Transfer in IJVs: The Role of Relational Embeddedness and the Impact on Performance. *Journal of International Business Studies*, vol 35, pp. 428-442.
- Dyer, J.H., Singh, H. (1998). The Relational View: Cooperative Strategy and Sources of Interorganisational Competitive Advantage. *Academy of Management Review*, vol 23, Iss: 4, pp. 660-679.

- Faems, D., Janssens, M., Madhock, A., Van Looy, B. (2008). Toward an Integrative Perspective on Alliance Governance: Connecting Contract Design, Trust Dynamics, and Contract Application. *Academy of Management Journal*, vol 51, Iss: 6, pp. 1053–1078.
- Gaur, A.S., Lu, J.W. (2007). Ownership Strategies and Survival of Foreign Subsidiaries: Impacts of Institutional Distance and Experience. *Journal of Management*, vol. 33, pp. 84–110.
- Geringer, J. M., Hebert, L.(1991). Measuring Performance of International Joint Ventures. *Journal of International Business Studies*, vol. 22, Iss: 2, pp. 249–263.
- Ghemawat, P. (2001). Distance Still Matters: The Hard Reality of Global Expansion. *Harvard Business Review*, vol 78, Iss: 8, pp. 137–147.
- Glaister, K.W. (2004). The Rationale for International Equity Joint Venture. *European Management Journal*, vol 22, Iss: 5, pp. 493–507.
- Globerman, S., Nielsin, B.B. (2007). Equity Versus Non-Equity International Strategic Alliances Involving Danish Firms: An Empirical Investigation of the Relative Importance of Partner and Host Country Determinants. *Journal of International Management*, vol 13, pp. 449-471.
- Gulati, R., Khana, T., Nohria, N. (1994), Unilateral Commitments and the Importance of Process in Alliances. *Sloan Management Review*, vol 35, Iss: 3, pp. 61–70.
- Gulati, R., Singh, H. (1998). The Architecture of Cooperation: Managing Coordination Cost and Appropriation Concerns in Strategic Alliances. *Administrative Science Quarterly*, vol 43, Iss: 4, pp. 781–814.
- Gulati, R. (1998). Alliances and Networks. *Strategic Management Journal*, vol 19, Iss: 4, pp. 293–317.
- Hagedoorn, J., Cloudt, D., Van Kranenburg, H. (2005). Intellectual Property Rights and the Governance of International R&D Partnerships. *Journal of International Business Studies*, vol 36, Iss: 2, pp. 175–186.
- Harrigan, K. (1985). *Strategies for Joint Ventures*. Lexington Books, Lexington, MA.
- Helm, R., Kloyer, M. (2004). Controlling Contractual Exchange Risks in R&D Interfirm Cooperation: An Empirical Study. *Research Policy*, vol 33, Iss: 8, pp. 1103-1122.
- Hennart, J. (1995). Transaction Costs Theory of Equity Joint Ventures. *Strategic Management Journal*, vol 9, Iss: 4, pp. 361 – 374.
- Hersch, L., Styles, C. (2001). International Joint Ventures: A Political Economy Framework. *Australasian Marketing Journal*, vol 9, Iss: 1, pp. 20-32.
- Hewitt, I. (2005). *Joint Ventures*. Sweet and Maxwell, London, UK.
- Hoetker, G., Mellewigt, T. (2009). Choice and Performance of Governance Mechanisms: Matching Alliance Governance to Alliance Type. *Strategic Management Journal*, vol 30, Iss: 10, pp. 1025-1044.
- Jacobs, J. (1992). *Systems of Survival: A Dialogue on Moral Foundations of Commerce and Politics*, Random House, New York, NY.
- Johnston, D. (1994). *International Petroleum: Fiscal Systems and Production-Sharing Contracts*, PennWell Publishing, Tulsa, OK.

- Kale, P., Singh, H., Perlmutter, H. (2000). Learning and Protection of Proprietary Assets in Strategic Alliances: Building Relational Capital. *Strategic Management Journal*, vol 21, Iss: 3, pp. 217–238.
- Kale, P., Dyer, J.H., Singh, H. (2002). Alliance Capability, Stock Market Response, and Long-term Alliance Success: The Role of the Alliance Function. *Strategic Management Journal*, vol 23, Iss: 8, pp. 747–767.
- Katsioloudes, M.I., Isichenko, D. (2007). International Joint Ventures in Russia: A Recipe for Success. *Management Research News*, vol 30, Iss: 2, pp. 133–152.
- Kogut, B. (1988). Joint Ventures: Theoretical and Empirical Evidence. *Strategic Management Journal*, vol 9, Iss: 4, pp. 319 – 332.
- Krishnan, R., Martin, X., Noordenhaven, N.G. (2006). When Does Trust Matter to Alliance Performance? *Academy of Management Journal*, vol 49, pp. 894–917.
- Kumar, S. (2005) The Value from Acquiring and Divesting: A Joint Venture: A Real Options Approach. *Strategic Management Journal*, vol 26, pp. 321–331.
- Larimo, J.A., Nguyen, H.L. (2015). International Joint Venture Strategies and Performance in Baltic States. *Baltic Journal of Management*, vol 10, Iss: 1, pp. 52-72.
- Lee, Y., Cavusgil, S. (2006). Enhancing Alliance Performance: The Effects of Contractual-based Versus Relational-based Governance. *Journal of Business Research*, vol 59, Iss: 8, pp. 896–905.
- Lowen, A., Pope, J. (2008). Survival Analysis of International Joint Venture Relationships. *Journal of Business and Economics Studies*, vol 14, Iss: 1, pp. 62–80.
- Lu, J.W., Xu, D. (2006). Growth and Survival of International Joint Ventures: An External-Internal Legitimacy Perspective. *Journal of Management*, vol 32, pp. 426–448.
- Lui, S.S., Ngo, H. (2004). The Role of Trust and Contractual Safeguards on Cooperation in Non-Equity Alliances. *Journal of Management*, vol 30, Iss: 4, pp. 471–485.
- Lumineau, F., Malhotra, D. (2011). Shadow of the Contract: How Contracts Structure Shapes Interfirm Dispute Resolution. *Strategic Management Journal*, vol 20, Iss: 8, pp. 865–884.
- Luo, Y. (2002). Contract, Cooperation, and Performance in International Joint Ventures. *Strategic Management Journal*, vol 23, pp. 903–919.
- Luo, Y. (2008). Procedural Fairness and Interfirm Cooperation in Strategic Alliances. *Strategic Management Journal*, vol 29, pp. 27–46.
- Makino, S., Chan, C.M., Isobe, T., Beamish, P.W. (2007). Intended and Unintended Termination of International Joint Ventures. *Strategic Management Journal*, vol 28, pp. 1113–1132.
- Malhotra, D., Murnighan, J.K. (2002). The Effects of Contracts on Interpersonal Trust. *Administrative Science Quarterly*, vol 47, Iss: 3, pp. 534–559.
- Mayer, K.J., Argyres, N.S. (2004). Learning to Contract: Evidence from The Personal Computer Industry. *Organisation Science*, vol 15, Iss: 4, pp. 394–410.
- Marjit, S., Broll, U., Mallick, I. (1995). A theory of overseas Joint Ventures. *Economic Letters*, vol 47, pp. 367–370.

- Micheli, P., Manzoni, J.F. (2010). Strategic performance measurement systems: benefits, limitations and paradoxes. *Long Range Planning*, vol 43, Iss: 4, pp. 465–476.
- Mikesell, R.F. (1975). *Foreign Investment in Copper Mining*, Johns Hopkins University Press, Baltimore, MD and London.
- Nichols, M.L. (2010). Accounting Implications of Production Sharing Contract. *Petroleum Accounting and Financial Management Journal*, vol 29, Iss: 2, pp. 1 – 15.
- Nippa, M., Beechler, S., Klossek, A. (2007). Success factors for managing international Joint Ventures: A review and an integrative framework. *Management and Organisation Review*, vol 3, Iss: 2, pp. 277–310.
- Oxley, J.E. (1997). Appropriability Hazards and Governance in Strategic Alliances: A Transaction Costs Approach. *Journal of Law, Economics, and Organisation*, vol 13, Iss: 2, pp. 387 – 409.
- Oxley, J.E. (1999). Institutional Environment and the Mechanism of Governance: The Impact of Intellectual Property Protection on the Structure of Inter-Firm Alliances. *Journal of Economic Behaviour and Organisation*, vol 38, Iss: 3, pp. 283 – 309.
- Ozorhon, B., Arditi, D., Dikmen, I., Birgonul, M.T. (2010). Performance of International Joint Ventures in Construction. *Journal of Management in Engineering*, vol 26, Iss: 4, pp. 209–222.
- Ozorhon, B., Arditi, D., Dikmen, I., Birgonul, M.T. (2011). Toward a Multinational Performance Measure for International Joint Ventures in Construction. *Journal of Construction Engineering and Management*, vol 137, Iss: 6, pp. 403–411.
- Pan, Y., Tse, D.K. (2000). The Hierarchical Model of Market Entry Modes. *Journal of International Business Studies*, vol 31, Iss: 4, pp. 535 – 554.
- Parkhe, A. (1993). Messy Research, Methodological Predisposition, and Theory Development in International Joint Ventures. *Academy of Management Review*, vol 18, Iss: 2, pp. 227–268.
- Parkhe, A. (1993). Strategic Alliance Structuring: A Game Theoretical and Transaction Cost Examination of Interfirm Cooperation. *Academy of Management Journal*, vol 36, Iss: 4, pp. 794–829.
- Parkhe, A. (1998). Understanding Trust in International Alliances. *Journal of World Business*, vol 33, Iss: 3, pp. 219–240.
- Parmigiani, A., Rivera-Santos, M. (2011). Clearing a Path through the Forest: A Meta-review of Interorganisational Relationships. *Journal of Management*, vol 37, Iss: 4, pp. 1108–1136.
- Phene, A., Fladmoe-Lindquist, K., Marsh, L. (2006). Breakthrough Innovations in the U.S. Biotechnology Industry: The Effects of Technological Space and Geographic Origin. *Strategic Management Journal*, vol 27, Iss: 4, pp. 369–388.
- Poppo, L., Zenger, T. (2002). Do Formal Contracts and Relational Governance Function as Substitutes or Complements? *Strategic Management Journal*, vol 23, pp. 707–725.
- Pisano, G.P. (1989). Using Equity Participation to Support Exchange: Evidence from the Biotechnology Industry. *Journal of Law, Economics, and Organisation*, vol 5, Iss: 1, pp. 109 – 126.
- Pongsiri, N. (2004). Partnerships in oil and gas production-sharing contracts. *International Journal of Public Sector Management*, vol 17, Iss: 5, pp. 431 – 442.

- Purkayastha, D. (1993). Firm-Specific advantages, Multinational Joint Ventures and Host Country Tariff Policy. *Southern Economic Journal*, vol 60, Iss: 1, pp. 89–95.
- Ren, H., Gray, B., Kim, K. (2009). Performance of International Joint Ventures: What Factors Really Make a Difference and How? *Journal of Management*, vol 35, Iss: 3, pp. 805–832.
- Reuer, J.J., Arino, A. (2002). Contractual Renegotiations in Strategic Alliances. *Journal of Management*, vol 28, Iss: 1, pp. 47–68.
- Reuer, J.J., Arino, A. (2007). Strategic Alliance Contracts: Dimensions and Determinants of Contractual Complexity. *Strategic Management Journal*, vol 28, Iss: 3, pp. 313–330.
- Reuer, J.J., Devarakonda, S.V. (2016). Mechanisms of Hybrid Governance: Administrative Committees in Non-Equity Alliances. *Academy of Management Journal*, vol 59, Iss: 2, pp. 510-533.
- Robins, J.A., Tallman, S., Fladmoe-Lindquist, K. (2002). Autonomy and Dependence of International Cooperative Ventures: An Exploration of the Strategic Performance of US Ventures in Mexico. *Strategic Management Journal*, vol 23, pp. 881–901.
- Robinson, D.T., Stuart, T.E. (2007). Financial Contracting in Biotech Strategic Alliances. *Journal of Law and Economics*, vol 50, Iss: 3, pp. 559–595.
- Robson, M.J., Katsikeas, C.S., Bello, D.C. (2008). Drivers and Performance Outcomes of Trust in International Strategic Alliances: The Role of Organisational Complexity. *Organisation Science*, vol 19, pp. 647–665.
- Ryall, M.D., Sampson, R.C. (2009). Formal Contracts in the Presence of Relational Enforcement Mechanisms: Evidence from Technology Development Projects. *Management Science*, vol 55, Iss: 6, pp. 906–925.
- Schilling, M.A. (2009). Understanding the Alliance Data. *Strategic Management Journal*, vol 30, Iss: 3, pp. 233–260.
- Shah, R.H., Swaminathan, V. (2008). Factors Influencing Partner Selection in Strategic Alliances: The Moderating Role of Alliance Context. *Strategic Management Journal*, vol 29, Iss: 5, pp. 474–494.
- Stein, H., Ginevicius, R. (2010). Overview and comparison of profit sharing in different business collaboration forms. *Journal of Business Economics and Management*, vol 11, Iss: 3, pp. 428–443.
- Styles, C., Hersch, L. (2005). Relationship Formation in International Joint Ventures: Insights from Australian-Malaysian International Joint Ventures. *Journal of International Marketing*, vol 13, Iss: 3, pp. 105 – 134.
- Thuy, L.X., Quang, T. (2005). Relational Capital and Performance of International Joint Ventures in Vietnam. *Asia Pacific Business Review*, vol 11, Iss: 3, pp. 389 – 410.
- Tong, T., Alessandri, T.M., Reuer, J.J., Chintakananda, A. (2008). How Much Does Country Matter? An Analysis of Firms' Growth Options. *Journal of International Business Studies*, vol 39, Iss: 3, pp. 387–405.
- Tyagi, R., Gupta, P. (2013). Gauging performance in the service industry. *Journal of Business Strategy*, vol 34, Iss: 3, pp. 4–15.
- Vaidya, S. (2009). International Joint Ventures: An integrated framework. *Competitiveness Review: An International Business Journal*, vol 19, Iss: 1, pp. 8 – 16.
- Van Kranenburg, H., Hagedoorn, J., Lorenz-Orlean, S. (2014). Distance Costs and the Degree of Inter-Partner Involvement in International Relational-based Technology Alliances. *Global Strategy Journal*, vol 4, pp. 280–291.

- Weber, L., Mayer, K.J. (2011). Designing Effective Contracts: Exploring the Influence of Framing and Expectations. *Academy of Management Review*, Vol 36, Iss: 1, pp. 53-75.
- Williamson, O.E. (1975). *Markets and Hierarchies: Analysis and Antitrust Implications*, Basic Books, New York.
- Williamson, O.E. (1985). *The Economic Institutions of Capitalism*, Free Press, New York.
- Williamson, O.E. (1991). Comparative Economic Organisation: The Analysis of Discrete Structural Alternatives. *Administrative Science Quarterly*, vol 36, Iss: 2, pp. 269–296.
- Woolthuis, R.K., Hillebrand, B., Nooteboom, B. (2005). Trust, Contract and Relationship Development. *Organisation Studies*, vol 26, Iss: 6, pp. 813–840.
- Ying, F. (1996). Research on Joint Ventures in China: Progress and Prognosis, In *International Joint Ventures in East Asia*. Baran, R., et al., eds, International Business Press, New York.
- Zahra, S., Elhagrasy, G. (1994). Strategic Management of International Joint Ventures. *European Management Journal*, Vol 12, Iss: 1, pp. 83-93.
- Zhang, Y., Li, H., Hitt, M.A., Cui, G. (2007). R&D Intensity and International Joint Ventures Performance in an Emerging Market: Moderating Effects of Market Focus and Ownership Structure. *Journal of International Business Studies*, vol 38, pp. 944–960.
- Zhong, L., Lahiri, S. (2010). Profit Share and Partner Choice in International Joint Ventures. *Review of International Economics*, vol 18, Iss: 3, pp. 552–561.
- Zollo, M., Reuer, J.J., Singh, H. (2002). Interorganisational Routines and Performance of Strategic Alliances. *Organisation Science*, vol 13, pp. 701–713.
- Zoubir, Y.H. (2000). Doing Business in Egypt. *Thunderbird International Business Review*, Vol 42, Iss: 2, pp. 329-347.

MANAGING CHANGE THROUGH STRATEGIC PLANNING IN SOUTH AFRICAN SCHOOLS FOR QUALITY IMPROVEMENT

Bongani Khumalo, Genesis Molepo, and Andile Mji
Tshwane University of Technology, South Africa

ABSTRACT

We explore three main critical issues, which are directly linked to sustainable quality improvement when transforming South African schools since 1994. Therefore, the purpose of this study was to explore how school managers manage change in their learning organisations with the intention of sustaining quality improvement. A qualitative research method was used in this study. One – on – one interviews were used to collect data. The results show that school managers identified curriculum transformation, infrastructure and human resource as critical in the learning and teaching environment. These issues have a potential of influencing change and learners' attainment either way in schools. In most cases, school managers painted a bleak picture regarding poor leadership and management in managing quality improvement in their schools. Therefore, it is recommended that the government should provide solutions wherein school managers can be provided with necessary skills in managing change in order to sustain quality improvement in education.

Keywords: Managing change, strategic planning, quality improvement, learning organization.

INTRODUCTION

The historical elections of 1994 created immense changes in stabilising South Africa in the political, economic, social and educational environment. This emergence and the national plan for education compelled the educational sector to change (Govender, Moodley & Parumasur, 2005). Schools like many public sector organisations have been subjected to legislation which aimed to produce change in the way in which the service is offered by all the stakeholders. In this regard, the co-operative links of society, the pressure of politics and government, and global changes made a compelling transformation on the educational sector. However, this is not the case, some schools find the educational changes more challenging than others. For example, schools that were cited to have been exposed to gross challenges in the implementation and sustenance of change are the schools which were previously marginalised and under-resourced (Du Plessis, 2014).

In fact, education has a remarkable potential to achieve the economic and social expectations of society when school managers transform learning organisations by providing good leadership and management. However, one undeniable fact is that when schools adhere to change, strategic educational goals are achievable. For instance, transformation of the education system is shaped by school managers that manage change in the entire learning organisations, have specific educational goals and the way of pursuing these goals (Govender, Moodley & Parumasur, 2005). When good leadership and management is provided learners' attainment is achieved. In actual fact, good leaders provide organisations with a clear direction and manage change informed by changes in the socio – economic, the political space as well as in the education sector [DoE, KZN] (2016). Effective managers are guided by the strategic goals of the department, implement all the departmental policies and ensure that the role of different stakeholders within the school is spelt out (Moloi, 2002). Good management skills and sufficient resources are of primary importance in major transformation process. Also, it is argued that in schools with good leadership and

management, effective change is implemented, therefore, learning and teaching takes place in an environment that is increasingly satisfying to its stakeholders (ibid).

Managing change for sustainable quality improvement in learning organisations create effective learning environment and positively influence the delivery of quality education. For instance, quality improvement in any organisation is influenced by the systematic management, monitoring and evaluation procedure adopted to ensure that the learning environment and the curriculum delivery of an educational institution meet the specified standards to achieve the set goals and produce outputs that will satisfy expectations of the institution's customers (Ayeni & Adelabu, 2011). It is worth to point out that quality improvement in learning organisations requires a change in order to transform the schools (ibid). When transforming any learning organisation issues related to curriculum management, suitable learning environment and human resource should be prioritised by implementing turn – around plan where there are challenges in managing change (Mahlangu, 2014).

LITERATURE

Change in Educational Organisations

There is wide spread agreement in the literature that change and renewal are among the most important aspects of an organization. It is worth to point out that when an organization fails to change, it stagnates and eventually declines. Consequently, the change and renewal can be regarded as essential for the development of an organization. An implementation of this is that the school as an organisation has to be seen as a dynamic entity (Theron, 1996). In fact, organizational change is perceived as an integral aspect of the functioning of an organisation. According to Theron (ibid), the goal of organisational change must be to improve the quality of working life of people involved in a school. Change represents the struggle between what is desired. It is also unavoidable feature of human experience. Change is a process pursued for and by people. Most important, according to Hall and Hord (1987), change in education begins and ends with individuals acting in unison to make schools effective.

A distinction can be made between planned and unplanned change. Planned change implies a deliberate alteration in the status quo. Planned change is always preferred, since change takes place according to specified goals and objectives. Change can take many forms, for example, social, technocratic, interactive and transformational change. The form of change that best describes the current changes in education system is “transformational change”. This involves radical change when the education system is working poorly. Most importantly, external and internal forces insist on radical changes; the change is dramatic in form and rapid in impact, and will ultimately change the entire culture of the organizational radically (Van der Westhuizen & Theron, 1996).

Characteristics of Change Management

The following are the characteristics of change management:

- Change is a process not a an event;
- Implementing educational innovations is a process; this process requires time. There are steps and phases in the process that can be used to plan and pace change.
- It is possible to anticipate much that will occur during change.
- In a change process, there are many predictable events and happening. Thus, the reactions to interventions can be anticipated. Consequently, many aspects of the change process can be planned. By planning for the expected, effective facilitators are better able to handle unanticipated occurrence, and to utilize their limited time and resources well.
- Innovations come in all shapes and sizes.
- The process of innovation encompasses either a product innovation (example text book or curriculum change) or process innovations, such as instructional procedures.
- Innovation and implementation are two sided of the coin of change process

- In all cases, regardless of the type of change, developing the innovation and implementing requires parallel sets of steps and procedures.
- To change something, someone has to change first.

The ultimate effectiveness of an innovation depends on whether teachers and others change in order to incorporate the new practice. The first step, therefore, is to develop a picture of how each staff member experiences the change process as an individual. According to the concerns-based model, change is a process for and by the people. It has a technical and a human side. It starts and ends with individuals, who in combination make schools effective (Hall & Hord, 1987). In the current change in education, the human side was apparently ignored. Teachers need to be supported and guided through this period of rapid change and punitive comments should be avoided.

Resistance to Change

It is argued that change becomes most meaningful when there is resistance to it and there will always be resistance to change (Van der Westhuizen Thereon, 1996). For example, it is argued that resistance is the general response to reliable, loss of personal choice and values, understanding the reasons for change, fear of change, mistaken perception in respect of change, and lack of skills (ibid). Change can be a painful process yet the outcome can be refreshing and rejuvenating for teacher, pupil and the school as a whole. This is clearly shown in the history of education in South Africa.

Historically, as far as black education was concerned, the demand for change in education was enormous. It took the form of boycotts, protest marches and strikes. The crux of all these events in black education is the demand for change and renewal of the existing system. In this regard, the poor results and lack of facilities in black education, elicited demands for change from pupils, teachers and the parent community to make education more productive (ibid). Change education occurred rapidly over ten years. After elections and the planning of the new non-racial educational system, which in turn meant a decrease in personnel, textbooks and stationary, teachers, teacher unions and parents resisted such cutbacks. For the parents it meant greater financial input by them. This gave rise to resistance from within and outside the education system.

According to Walter and Vogt (1987), resistance to change can originate from the system or from the individual. Some of the causes of resistance to change during this phase are the following:

- A failure to involve people who are affected by the changes in the planning phase.
- The changes are not noted in writing and circulated appropriately.
- The goal of the changes are not clearly articulated and cleared with people involved with the changes.
- Working group recommendations are not accepted.
- Teachers are not kept informed of the process of changes.
- Concerns by teachers that the changes might prove disastrous are not addressed.
- There is excessive pressure of work during the implementation phase of the changes.

THE PROBLEM

The present focus in the educational arena at national, provincial and institutional levels is change, transformation, and transition. One of the challenges that the post-apartheid South African democracy faces is to transform schools through strategic planning and effective management. In fact the development of the nation lies on the effectiveness of how change re-energises the education system (Govender, Moodley & Parumasur, 2005). Some schools found that the educational changes are more challenging and some even resist change. For instance, lack of proper infrastructure, curriculum management and lack of skills in leadership hinder the change process in learning organisations. Poor leadership management and administration are major challenges in some learning organisations. This suggests that quality improvement is extremely difficult if change is not managed. In actual fact, we wanted to investigate issues, which are directly linked to managing change and sustainability quality improvement in learning

organisation. Ultimately, the goal was to recommend plausible solutions that would possibly address radical transformation in education system.

Study site

This study was conducted in both rural and urban areas of Umzinyathi District where the first author works. In general, since 1994 there has been a slow progress in the management of change in these schools as a result the sustainability of quality improvement remains a challenge. Despite the global changes all over the world, some of the schools in this District are unable to implement educational policies. In some schools poor leadership management and administration, lack of curriculum transformation and resources affect the change process. The fluctuation in learner performance is the indication of problems in managing change and increasing resistance towards embracing change.

RESEARCH QUESTION

The main research question of this study was: *What are school managers' perceptions on managing change in their learning organisations?* To answer this question, three sub-questions were used in one-on-one interviews with the participants. These were: (i) *How do you perceive change in curriculum management using technology and how it would enhance teaching and learning?* (ii) *How does the learning environment/infrastructure affect the management of change in learning organisations?* (iii) *Which factor identified by school managers that will impact on the efficiency and effectiveness of the institution in the short and long term?*

METHOD

The study used the qualitative approach because qualitative research, as defined by McMillan and Schumacher (2006), is an inquiry in which researchers collect data in face-to-face situations by interacting with selected persons in their settings. Although a large of data was generated from interviews which were tape recorded, only relevant information was used in the data analysis. To collect data, three techniques were used. These were interviews, observations and document analysis. The three were used in order to collate and make sense of the information collected from different perspective. This process of collecting and analysing data from different techniques is referred as triangulation. The qualitative nature of this study limits the generalisation of the results to all schools, but we intend that the instruments used be valid and that the findings be generalizable to school settings working under similar difficult education contexts (Moloi, 2010).

PARTICIPANTS AND PROCEDURE

Sample

The population comprised the decision makers involved in managing the change process from different learning organisations, namely, school managers. The population comprised of 50 secondary schools. The researchers in this study used the non-probability sampling to find out the daunting challenges facing school managers in managing transformational change as they are the change agents. Fifteen school managers were interviewed from schools who participated. For logistical reasons, such as the ability to have access to all schools and to minimise transport costs, the intention was to interview a sample of 20 members of the population. However, five participants were unavailable to be interviewed on the appointment dates. The school managers were purposefully selected because they were able to provide first-hand information and they are the first implementers of policies on their schools. Therefore in this qualitative study, the interviews were limited to being conducted with fifteen school managers.

Instrument and procedure

Data were collected by means of open ended interviews. The aim of the interviews was to give an independent voice to the participants. In particular, each participant was encouraged to provide as honest a view as they felt was applicable to them. In collecting the data we ensured that we visited the participants in their schools. In doing this, we were mindful of the argument that a researcher has to go to the setting of the study because if participants are removed from their setting, this may lead to contrived findings that are out of context (Cresswell, 1998).

RESULTS

Here, an analysis of the collected data, its interpretation as well as the findings from the participants' perspective is provided. In particular, participants' perceptions regarding the management of change in their learning organisations is outlined. Their views were coded into a themes or categories with the aim of deriving meaning from these. The themes were labelled using in vivo coding. In other words, responses that were judged to convey the same or similar views were grouped together. Importantly, actual words or phrases used by the participants were then used to name the emerging themes in this study. Table one records the participants' biographical information.

Table 1: Biographical data of the sample (N = 15)

Category	N	%
Gender		
Women	5	33
Men	10	67
Age		
30 – 39	5	33
40 +	10	67
Highest academic qualification		
Diploma (e.g. Diploma in primary education)	7	47
Degree or higher (e.g. B.A. or B.A. Honours)	8	53
Teaching experience (Educators)		
0 – 9	6	40
10 or more	9	60

Participants' Views

Here, pseudonyms are used for all the fifteen participants. The participants are referred to as: Ms Buthelezi, Ms Cele, Ms Dlamini, Ms Fakude, Ms Gumede, Mr Hadebe, Mr Jiyane, Mr Ngubane, Mr Khuzwayo, Mr Zulu, Mr Zondo, Mr Zungu, Mr Venter, Mr Koos, Mr Kobus. Here participants were asked: *How do you perceive the use of technology and how it would enhance curriculum management in your institution?* There was only one theme emerging from this question. This was named: *Curriculum management using ICT*. All participants viewed technology programmes as a contributing factor to manage curriculum in learning organisations. In this regard, Ms Cele said ... these technology programmes will assist educators to be lifelong learners and sustain quality improvement in learning organisations. For example, Ms Dlamini said "... novice and experienced educators will not battle with the management and implementation of the curriculum. Using technology programmes to teach are very good in terms of knowledge content ...". On the same view, Mr Venter argued, "... using technology in schools will promote time management and progression of assessment. For instance, Ms Fakude indicated that ... the implementation of the latest technology should assist the learners to enjoy learning and teaching. On the same view,

Ms Buthelezi said ... technology is learner centered and not educator centered and it will allow problem solving skills to be developed and learners can work with others in a very informal but constructive way.

In the second interview question, participants were asked: *How does the learning environment/infrastructure affect the management of change in learning organisations?* Most participants expressed their views on how the management of change is affected. Based on the responses this theme was named: *Learning environment*. Almost all the participants that they had a problem with the provision of infrastructure. For example, Mr Hadebe indicated that "...the Department of Education is responsible for the provision of infrastructure in schools." Mr Jiyane, expressing his disappointment, said "... my school had to wait for its turn to receive desks and chairs. When the researchers accessed the school correspondence, they discovered that in certain instances schools have to wait for a period of more than 10 years. The waiting period after the initial date of processing application by the physical planning section cannot be predicted. The provision of quality education in managing change lies on the provision of proper infrastructure and understanding of contextual factors leading to poor interpretation of poor environment. In this regard, Mr Ngubane said "... to manage change we need modernised facilities such as lecture halls, theatre halls, conference rooms, and data projectors. This suggests that good learning environment will aspire educators to be on the same par with well developed countries. When the schools possess good infrastructure teaching and learning is improved. For example, Mr Koos indicated "... I would like my school to be filled with fully equipped with necessary resources in order to promote effective teaching and learning."

When responding to question: (iii) *Which factor identified by school managers that will impact on the efficiency and effectiveness of the institution in the short and long term?* The participants identified human resources as a matter that needed attention when managing change at Umzinyathi schools. This theme was referred to as: *Human resources*. Lack of competency in school managers affect the provision of quality education in rural schools. For example, Mr Zungu mentioned that "... lack of leadership management and administration impacts negatively in the provision of quality education in my school." On the same vein, Mr Khuzwayo indicated "... lack of skills and knowledge in managing change leads to school managers failing to implement policies". Furthermore, Mr Kobus commented "... some school managers are appointed without considering their competency as a result they are unable to execute directives towards implementing change. For example, Mr Zulu said, "... I have school improvement plan but it is not properly implemented. Sharing the same sentiment, Mr Venter said "... The crucial activities that need urgent attention are not attended as a result our strategic planning is not effective. Furthermore, Mr Koos said "... educators' motivation has been affected by the multiple education changes..." This leads to some educators resist change.

IMPLICATIONS OF FINDINGS

The implications of the issues raised here mean that there is an urgent need to address the participants' concerns because school managers are the main focus point in the improvement of schools. For instance, management of change has not been cost effective or efficient in building sustainable learning environment for the transformation process or enabling policies to impact significantly on the majority of schools. The need for transformation may be seen from Mr Khuzwayo's argument that lack of skills and knowledge in managing change leads to school managers failing to implement policies. In this regard the effective management of change and quality improvement in learning organisation requires effective managerial leadership, motivation and good management skills.

STUDY SUMMARY

In this study, the aim was to explore how school managers manage change in their learning organisations with the intention of sustaining quality improvement in Umzinyathi district. It should be noted that the research site of this study is one of the twelve districts under the KwaZulu-Natal provincial department of education. Since the first democratic election in this district, there has been a slow progress in the management of change as a result the sustainability of quality improvement remains a challenge. Regarding this, one of the changes and challenges that the post – apartheid South African democracy faces is to transform education and create excellent conditions for effective teaching and learning (Lethoko, Heystek& Marie, 2001). The results indicated that participants identified curriculum management using ICT, learning environment and human resources that they perceived to have an

impact on providing sustainable quality improvement in learning organisations. In this regard, school managers have a responsibility to understand the change process (Govender, Moodley & Parumasur, 2005).

DISCUSSION

Managing change has become a critical factor in transforming schools as learning organisations. When change is managed effectively by school managers it improves quality, accountability and establish a new direction for the learning organisation (Govender, Moodley & Parumasur, 2005). Therefore, change management needs strong leadership and support from departmental officials. The first theme that emerged in this study was about curriculum management using ICT. For instance, Ms Cele revealed that technology programmes assist school managers to become lifelong learners and sustain quality improvement in learning organisations. Regarding this, ICT are increasingly used in schools to support teaching and learning based on the understanding that this will improve teaching and learning outcomes (Makgato, 2014). Therefore, the role of educational technology is to support the development of subject content knowledge, related pedagogical content knowledge and classroom competence.

The second theme to emerge is related to infrastructural provisioning in schools. Here the participants identified poor provisioning of infrastructure as problematic. In this regard, poor infrastructure means that some schools are unable to transform and manage change. The problem with the lack of infrastructure is that 'smart classrooms' are therefore a dream to some schools. What seems to have been a problem is non-delivery by the authorities. For instance, Mr Jiyane revealed that he had to wait for a period of more than 10 years for the school buildings he had applied for. This is a very important issue about which Clarke (2009, p. 11) points out that "... effective schools are characterised by the environment that is attractive and inviting physical landscape necessary for teaching and learning."

It is argued that school managers have a responsibility of creating a sound culture of teaching and learning in which effective education can take place (Kruger, 2003). For instance, Mr Zungu mentioned that lack of leadership management and administration impacts negatively on the provisioning of quality education in schools. About this, it should be pointed out that leadership training has not been effective in building management and leadership capacity, skills and competencies for the transformation process (Moloi, 2007).

CONCLUSION AND RECOMMENDATIONS

The empirical data in this study indicated that participants' perceive that inability to manage change compromises the sustainability of quality improvement in education. In fact technology is seen as the tool that will be used to manage and transform teaching and learning in the 21st century. In fact, there should be enough computers at schools even though there are other invention such as delivery of tablets in order to supplement each other and should be regular computer literacy and training for educators (Makgato, 2014). Therefore, it is recommended that school managers and Department of Basic Education should evaluate the impact of technology on curriculum delivery; then develop programmes to assist schools. Furthermore, what this study's participants seem to suggest is that good infrastructure will assist learners to perform better. For example, it is pointed out that good buildings are essential in improving student academic achievement (Fisher, 2001). The implications of the issue raised here mean that there is an urgent need to address the participants concern. It is important that government should provide proper and adequate school infrastructure. The management of change is critical in the transformation of education and in the development of strong leadership and management. School managers who are not competent and without necessary skills cannot lead the process of transformation. However, if sound principles in this regard are not implemented, many schools could be heading for situations that could ultimately frustrate improvement of sustainable change in education. Therefore, it is recommended that strong leadership with new skills development is needed in managing change.

REFERENCES

- Ayeni, A., J & Adelabu, M., A (2011). Improving learning infrastructure and environment for sustainable quality assurance practice in Secondary Schools in Ondo State, South - West, Nigeria. *International Journal of Research Studies in Education*, 1 (1), 61 – 68.
- Clarke, A. (2009). *The Handbook for School Governors*. Cape Town: Kate McCallum.
- Creswell, J. (1998). *Qualitative inquiry and research design*. London: SAGE.
- Du Plessis, P. (2014). Problems and complexities in rural schools: Challenges of Education and Social Development. *Mediterranean Journal of Social Sciences*, 5 (20), 1109 – 1117.
- DoE, KZN (2016). *Gearing up for change: Towards improving learner attainment, effectiveness and efficiency in education*. Pietermaritzburg: Government Printer.
- Fisher, K. (2001). Building better outcomes: The impact of school infrastructure on student outcomes and behaviour. *Schooling Issues Digest*. Retrieved October 24, 2013 from <http://sdpl.coe.uga.edu/research/kenfisherbuilding.pdf>
- Govender, P., Moodley, S., & Parumasur, S., B. (2005). The management of change at selected higher education institutions: An exploration of the critical ingredients for effective change management. *South African Journal of Industrial Psychology*, 31 (1), 78 – 86.
- Hall, G., E. & Hord, S., M. (1987). *Change in schools: Facilitating the process*. Albany: State University of New York.
- Kruger, A., G. (2003). Instructional leadership: The impact on the culture of teaching and learning in two effective secondary schools. *South African Journal of Education*, 23 (3), 206 – 211
- Lethoko, M., X, Heystek, J., & Maree, J., G. (2001). *South African Journal of Education*, 21 (4), 311–317.
- Mahlangu, V., P. (2014). Strategies for Principal-Teacher Development: A South African perspective. *Mediterranean Journal of Social Sciences*, 5 (20), 1378 – 1384.
- Makgato, M. (2014). Challenges contributing to poor integration of educational technology at some schools in South Africa. *Mediterranean Journal of Social Sciences*, 5 (20), 1285 – 1292.
- McMillan, J., H. & Schumacher, S. (2006). *Research in education: A conceptual introduction* (6thed.). USA: Pearson Education, Inc.
- Moloi, K., C. (2002). *The school as a learning organisation. Reconceptualising school practices in South Africa*. Pretoria: Van Schaik Publishers.
- Moloi, K. (2007). An overview of education management in South Africa. *South African Journal of Education*, 27, (3) 463 – 476.
- Moloi, K., C. (2010). How can schools build learning organisations in difficult education contexts? *South African Journal of Education*, 30, 621 – 633.
- Van der Westhuizen, P., C. & Theron, A., M. C. (1996). *Resistance to change in education*. Pretoria: Van Schaik Publishers.
- Walter, T., L. & Vogt, J., F. (1987). *The school administrator as change agent. Skills for the future*. NASSP Bulletin, 71 (502), 41 – 48.

THE VALUE OF CORPORATE SOCIAL RESPONSIBILITY FOR BENEFICIARIES: A SOUTH AFRICAN CASE STUDY

Jessica Knight, Thina Mazibuko and Geoff A Goldman
University of Johannesburg, South Africa

ABSTRACT

This research aims to understand the perspective of the beneficiaries of Corporate Social Responsibility (CSR) initiatives in terms of the contribution these initiatives make toward uplifting communities. This perspective is under-represented in literature, resulting in ambiguity on the value of CSR initiatives. Following a qualitative case study design, semi-structured interviews were conducted with eight beneficiaries of the OUTsurance Pointsman Program (OPP). Data were analysed by means of qualitative content analysis. Findings revealed three major contexts in the lived experience of research subjects, namely, working context, living context and the community upliftment context. Although this study does not affirm the notion that there is a difference between organisational agenda and beneficiary experience regarding CSR, it does show that true organisational commitment to CSR results in benefits experienced by the beneficiaries of CSR initiatives.

Keywords: CSR, community development, job creation, beneficiary, qualitative research.

INTRODUCTION AND BACKGROUND

When assessing the degree to which Corporate Social Responsibility (CSR) initiatives have contributed to social issues, such as community development or job creation, one must understand the perspective from which these contributions are assessed. Two perspectives exist, the organisational perspective and the beneficiary perspective. The organisational perspective assesses 'contribution' in terms of how CSR initiatives contribute to the attainment of business objectives (Newell & Frynas, 2007). The beneficiary perspective focuses on the contribution CSR makes to the quality of life of those who are the targets of CSR initiative (Pimpa, Fray & Gekara, 2012). This perspective may offer a more accurate representation of the value and success of CSR, as it focusses on people who are directly affected by CSR, and the benefits that have accrued to them as a result.

Over time, the context of, and reasoning behind, CSR has changed. The current expectation associated with CSR is one that balances profit-making with social responsibility, and organisations should be encouraged to be socially responsible, as not only is there organisational benefit, but it also implies a moral sense of support to the community (Hinson & Ndhlovu, 2011). Organisations are forced to concede, one can argue, that acting socially responsible is just as important for an organisation as creating value for its direct stakeholders. Literature reflects an evolution of social responsibility in business to what is now known as Corporate Social Responsibility (Carroll, 2008). The CSR body of knowledge has burgeoned in the latter half of the 20th century, and emphasis has shifted from CSR being something that benefits organisational performance, to an emphasis on CSR being something that should benefit the community (Carroll, 2008). In the 21st century, it would appear as though the CSR debate has adopted a moral and ethical flavour, and started forming part of normal business practice (Moura-Leite, 2011).

In South Africa, CSR has also evolved over time, resulting in the adoption of Corporate Social Investment (CSI) as the dominant point of view (Ramlall, 2012). Central here is the political and economic history of South Africa

and legislation stemming from its democratisation (Hinson & Ndhlovu, 2011), which made investment into social upliftment, especially by business, a pivotal part, of CSI in South Africa. However, 'Investment' implies a potential return, which often taints the motives behind CSI initiatives (Ramlall, 2012; Hinson & Ndhlovu, 2011).

Despite the adoption of triple bottom line reporting, it seems as though few organisations view themselves as change agents through their CSR endeavours (Jamali, Karam & Blowfield, 2015). Normally, the value of an organisations' CSR initiatives is assessed by means of scales of efficiency, productivity and profitability as opposed to the benefits accruing to the beneficiaries of CSR (Jamali *et al.*, 2015). As a result, CSR becomes a justifiable business expense and community priorities are neglected (Newell & Frynas, 2007). Furthermore, organisations often lack an understanding of the culture within the target community, and do not always understand the needs of the community, resulting in irrelevant or detrimental CSR initiatives (Barkemeyer, 2009). Community driven CSR should combat ineffective CSR. Issues should be identified by communities, with organisations then investing resources to create solutions to these issues (World Bank, 2006). Literature does not provide much regarding whether the perspective of those that are meant to benefit from CSR endeavours, have been considered.

LITERATURE REVIEW

Kloppers (2014) purports that the meaning of CSR differs across contexts, and is influenced by factors such as belief and culture. CSR is viewed as a commitment to the consistent and continued enforcement of ethical standards whilst making a positive contribution to economic development and improving the quality of life of the community that the organisation operates in (McWilliams & Siegal, 2000; Kloppers, 2014). Early evidence of socially responsible behaviour by organisations stems from the Industrial Revolution, where philanthropically minded factory owners established welfare funds for employees, and supported legislation to manage factory work and working conditions (Carroll, 2008; Hopkins & Cowe, 2004). This also marks the beginnings of the debate regarding the purpose of the business organisation as a profit making entity versus an instrument for societal development (Jamali *et al.*, 2015). The rise to prominence of CSR highlights the interplay between the organisation, government and society. For long, business decision making was based on the objective of profit maximisation. However, this notion is being challenged, and the nett result is that organisations also have to consider the ethical, legal, social, moral and economic impact of their decisions (Hinson & Ndhlovu, 2011). This literature review will present some of the major theoretical perspectives on CSR to highlight some of the views that exist on the issue. The discussion then focusses on CSR in the South African context, and concludes with highlighting the role CSR plays in important societal issues, such as community upliftment.

Theoretical Perspective on CSR

As eluded to, different views exist about CSR, and this is evident from the plethora of theories that exist on the topic. Herewith, a few of the most pertinent theories:

- **Instrumental Theory:** Focusses on wealth maximisation and how CSR is instrumental in this objective. Friedman was a proponent of this theory, and purported that the sole purpose of an organisation is to maximize profits for shareholders (Friedman, 1970; Lazonick & O'Sullivan, 2010;). This has been the dominant view on CSR in the 1970's and 1980's. The concern for profit does not exclude stakeholder interests, as addressing stakeholder needs and interests could result in wealth creation for shareholders (Garriga & Mele, 2004).
- **Political Theory:** focuses on the interaction between an organisation and society as well as the position and power of the organisation. Political theories include Corporate Constitutionalism and Corporate Citizenship (Corbett & Spencer, 2009; Garriga & Mele, 2004).
- **Integrative Theory:** examines how organisations merge social demands, growth and continuity. Management should consider how these social demands align with the values of the organisation to ensure mutual benefit for the organisation as well as the beneficiaries of CSR initiatives (Garriga & Mele, 2004).
- **Ethical Theory:** focuses on the association between business and society, and assumes that an organisation must consider the 'right thing to do' (Garriga & Mele, 2004). Ethical theories include stakeholder theory, universal rights theory and sustainable development theory (Garriga & Mele, 2004; Louw & Venter, 2006).

These theories manifest themselves in the motivation to embark upon CSR initiatives beyond what is legally required, and could influence the extent and relevance of CSR and will have an effect on the perspective of the intended beneficiary of CSR. What is also apparent, is that literature on CSR is mostly focussed on the organisational perspective. In other words, it examines what the organisation should do, how the organisation should interact with other stakeholders, and what benefits will accrue to the organisation through CSR. However, CSR implies a beneficiary that benefits from it, and literature exhibits a definite gap in our understanding of how these beneficiaries experience and interpret CSR initiatives, and the benefits that accrue to these beneficiaries.

Corporate Social Responsibility and Corporate Social Investment in South Africa

Feldberg's inaugural lecture in 1972 at the University of Cape Town, entitled "*Business profits and social responsibility*", was a pivotal moment in South African CSR (Le Bruyns, 2009). This lecture emphasised the responsibility of business to serve the needs of society (Slabbert, Prinsloo, Swanepoel & Backer, 1998). With economic sanctions imposed against South Africa in the 1980's, CSR was shaped by the so-called Sullivan Principles (Seidman, 2003). MNC's that opted not to pull out of South Africa had to adhere to these principles, which is viewed as another watershed moment for CSR in South Africa (Slabbert *et al.*, 1998). The 1994 democratic elections in South Africa resulted in the transformation of the business environment, and the pressure on organisations to be active in CSR initiatives grew, resulting in organisations using the Reconstruction and Development Program program to define their CSR programs (Spicer, 2002). The introduction of the series of King Reports on corporate governance, the first of which was published in 1992, is also seen as a pivotal moment in the evolution of CSR in South Africa. These reports include a Code of Corporate Practice and Conduct, which aims to encourage a culture of good corporate governance and citizenship in South Africa (King Committee on Corporate Governance, 2002). The second King Report emphasised triple bottom line reporting, whilst King III introduced the need for an annual integrated report on the elements of the triple bottom line (Ramlall, 2012). CSR in South Africa is not limited to the integration of social and environmental aspects into organisational operations, as it also includes Affirmative Action, Broad Based Black Economic Empowerment, and Skills Development, seeking to redress the imbalances of apartheid (Hinson & Ndhlovu, 2011).

In South Africa, two forms of social responsibility exist, namely Corporate Social Responsibility (CSR) and Corporate Social Investment (CSI). Although similar, they are not synonymous (Hinson & Ndhlovu, 2011). The nature of these concepts has been shaped by apartheid and its aftermath (Freemantle & Rockey, 2004). CSI is uniquely South African, and is seen as a more focused version of CSR aiming for sustainable development and governance (Hinson & Ndhlovu, 2011). CSI is often considered to be a form of corporate philanthropy, where one percent of an organisation's profits are allocated as a minimum contribution toward socially responsible initiatives (Hinson & Ndhlovu, 2011). These initiatives focus on community upliftment and have a developmental focus (Fig, 2005). CSR and CSI (often referred to as CSR/I) are seen as important forces for social change and curbing poverty in South Africa. These initiatives have improved the quality of life for workers, provided employment, and have developed networks of business partners and suppliers (Newell & Frynas, 2007).

CONTEXT OF THE STUDY

The study was conducted amongst the targeted beneficiaries of a CSR initiative embarked upon by OUTsurance, one of South Africa's largest insurance companies. The initiative is known as the "OUTsurance Pointsman Project" (OPP). OUTsurance is thus the sponsor of the project, and they contract an intermediary (the *Private Company*) to roll the project out. The purpose of the project is to (OUTsurance, 2016):

- Provide a solution to the pressing issue of traffic lights not working and not enough Police points-people to regulate traffic flow in peak hour periods in Johannesburg, Pretoria and Cape Town.
- To contribute to job creation, by training unemployed people to be points-people.

OUTsurance provides the funding for the *Private Company* to train points-people. The *Private Company* provides transport to points-people in the form of moped scooters. Thus, more points-people are available to help regulate traffic flow, as traffic light outages are common in South Africa, with not enough Police to handle the situation. With this initiative, the issue of traffic light outages is addressed, but the major impact (and thus the targeted beneficiary) is in providing employment for people from less privileged communities (OUTsurance, 2016).

RATIONALE FOR CONDUCTING THE RESEARCH

Evidence suggests that the perspective of the beneficiaries of CSR initiatives is under-represented in literature. This leads to ambiguity surrounding the contribution of CSR, as organisational objectives remain the focal point of measuring ‘success’ of these initiatives. Thus, there can be a lack of understanding regarding how these beneficiaries perceive CSR initiatives and the benefits that accrue to them from these initiatives. Forthcoming from this problem statement, the following research question is presented:

How do the beneficiaries of CSR initiatives experience the contribution of such initiatives toward addressing issues such as community development, job creation and poverty alleviation?

To address this question, the objective of this paper is:

to understand how the beneficiaries of CSR initiatives experience the contribution these initiatives make toward upliftment of society.

METHODOLOGY

The Interpretive paradigm was employed in this study, as the objective of this study seeks to understand the experiences of beneficiaries of CSR initiatives and the reality of their lived experiences. Subsequently, a qualitative research approach was decided upon, as qualitative research is best suited to exploration and understanding of meaning ascribed to social problems (Creswell, 2009). The study employed an exploratory, case study design. A case is signified by having observable parameters with a unique dynamic that exists within these parameters (Babbie & Mouton, 2004). The case in question here is the (OPP), which includes the dynamic between OUTsurance, the *Private Company* and the points-people employed. The research population consists of individuals who benefit from the OPP, thus the points-people themselves. OUTsurance was excluded as they are the sponsor of the OPP and not directly involved with the roll-out thereof. The *Private Company* was also excluded, as they are not the beneficiary of the OPP, but they are responsible for the roll out of the OPP as well as the training of new points-people. Thus, the trained points-people constitute the research population of this study.

As with most qualitative studies, non-probability sampling, and more specifically purposive sampling, was employed. The information required to identify potential research subjects from the ranks of the points-people was obtained from the *Private Company*. A target sample size of ten research subjects was set, as it was felt that this represented a sample that would provide sufficient data to address the research question. However, factors such as willingness to participate and availability of the research subjects, resulted in a final sample of eight research subjects. Data were collected by means of semi-structured interviews. During the interviews, data were gathered by means of video or audio recording and note-taking to accommodate non-verbal responses as well as the researcher’s thoughts on the gist of the interview (Fox & Bayat, 2007). The collected data were analysed through Qualitative Content Analysis, employing Creswell’s 4 stage process of qualitative data analysis (Creswell, 2009).

RESEARCH FINDINGS AND DISCUSSION

Research subjects were between 26 and 36 years of age, five female and three male, and all emanated from underprivileged backgrounds. Although not their first language, all research subjects were conversant in English. Initial coding resulted in 19 categories, and further analysis resulted in the emergence of three dominant themes, namely (i) the Working Context, (ii) the Living Context, and (iii) Community Upliftment context. These will now be

expanded upon in turn. In the interest of brevity, a small number of supportive excerpts from interviews are presented. More evidence is available upon request from the authors.

Theme 1: The Working Context

Understanding how research subjects' current situation differs from their historic situation allows one the opportunity of evaluating whether the Sponsors' intent with the OPP has actually been realised. Most of the research subjects were previously employed in entry level jobs. Thus, the career advancement prospects of these people seemed bleak before they got involved with the OPP, a reality faced by many people from underprivileged backgrounds in South Africa. This denotes the **historic situation** of research subjects. From the interviews conducted, it was evident that part of the OPP involves continual training and learning, underscoring the importance of **skills development** in this working context. The skills learnt during training are developed further as they get utilised on a daily basis. Research subjects reflected that the most prominent skills acquired through being part of the OPP were, *inter alia*, controlling traffic, patience and communication. Furthermore, the points-people felt that their environment changed on a daily basis, facilitating constant learning from new experiences. Points-people also felt that they had learnt about issues such as safety, vigilance, behavioural and emotional skills.

The opportunity for job advancement, or **progression**, was raised by some research subjects. Apart from the opportunity to progress from a static points-person to a mobile points-person, training is also offered to points-people, something research subjects are particularly excited about. Points-people are selected and interviewed, and if successful, they enter a functional training program. This spans seven months and is intended to create future leaders for the *Private Company*. Research subjects feel that this training also aids personal skills development. **Work-life experience** also emerged from the interviews, which encompassed aspects of job enjoyment as well as challenges encountered. Without exception, research subjects expressed a sense of enjoying their job, that what they were doing was making a difference to the community, and hence they felt a sense of belonging. Some negative sentiments were expressed, but these were situational rather than systemic. No negative sentiments were expressed toward the OPP or the *Private Company*. Research subjects cited motorist's appreciation and understanding as factors that also contributed to the enjoyment of their jobs. **Status** emerged as an important issue across all three the dominant themes. Seen important by all research subjects, it does not encompass a large enough spectrum of categories to be a stand-alone theme. Research subjects revealed that the *Private Company* employs a formal process for rewards and recognition through a compliments platform based on motorists' compliments. This is shared internally, resulting in a sense of achievement being felt by the points-people. This elevates their experience of their job beyond something mundane to something they are indeed proud of. The following table contains excerpts from interviews supporting the views expressed above:

"... I love [Private Company] because I am who I am today because of it, and today I never thought I can work with laptop because I hated office work. I wanted department of health but this functional training changed my mind. I've registered with Damelin now for HR, I will start 2 nd February next year..."
"...No honestly I'll tell you I really really do enjoy my job because ever since I came here like [Private Company] has a platform where people give compliments, the people we help on the street. So ever since I was here we getting compliments almost each and every month. Today I was one of those people that got compliments from motorists. They send complimentary emails they also mention our names so today we got chocolates and everything celebrating that hey guys you are doing a great job, you arrive on time and you arrive safely. So I would say that I do enjoy my job because we do it with passion, greet people with smile, do it with integrity, professionalism, honesty, we are always on time, obviously that comes with the enjoyment for work..."
"... yes we do go for training at JMPD Academy, I think it was for a month where they teach you how to obviously control traffic in the busy intersection and then also you come back from training, you come back here at [Private Company] they also give you another training just to make sure that you are a right person. because normally what happen is you find people now they are nervous when they are in training and you end up being hit by the car so they have to make sure that you are fully trained..."

Theme 2: The Living Context

All research subjects were of the opinion that the OPP had a positive effect on their living experience, as everybody described how they had acquired personal knowledge and skills. This has not only resulted in personal development, but has also contributed to an all-round betterment of family life. Interviews revealed that people felt that the OPP

enabled them to be bread-winners for their families, thus contributing positively to the economy. Research subjects felt an increased ability to **support** their families and the community, which in turn has led to an improvement in living standards. Research subjects feel that they have gained access to greater opportunities.

The interviews revealed that the points-people have been able to achieve a multitude of milestones, such as acquiring their own homes and vehicles. Others have started their own businesses. This implies that the financial independence research subjects have experienced, put them in a position to secure funding to pursue personal aspirations. Research subjects also mentioned that the OPP empowered them to provide education for their children. This implies **development**, not only of the individuals, but also of their immediate families. Thus, the OPP reaches further than the participant as an individual. The following extracts support the claims presented:

"...my kids can go to school for that and I still managed to pay the transport and buy groceries and buy things for me and the kids as well. I can send money home for them to eat as well..."
"...most of them are bread winners and they have families, not only their own families even the extended families..."
"...But through this project they were able to go to school achieve certificates, diplomas, degrees, they were able to purchase houses and others have even started businesses and they're driving nice looking cars..."

Theme 3: Community Upliftment Context

All research subjects stated that the OPP contributed to **poverty alleviation**. Looking at their own journeys, the points-people mentioned that they came from underprivileged backgrounds, and the OPP helped them fight poverty through employment. They have acquired skills and a constant income. The research subjects reflected that they were either unemployed or working for a minimum wage before entering the OPP, and they did not always have the means to support their basic needs and the needs of their families. Research subjects stated that the OPP has allowed them to grow and to develop themselves. One points-person stated that a number of people from his community now works for the *Private Company*, which has greatly assisted in the development of this specific community. Furthermore, all research subjects mentioned that the safety of commuters was a focal point of the OPP. As a result they took **pride** in being able to keep all commuters safe on the roads.

The OPP initiative has created a CSR cycle where the points-people, as the intended beneficiaries, are encouraged to actively participate in CSR activities. Through this initiative, points-people are able to contribute and participate in their communities by donating food parcels to various charities. They concur that the OPP has allowed for a cycle of community development. Research subjects further purported that since they started working at the *Private Company*, they have gained community respect. This respect translates into referent power, and encourages others in the community to follow their footsteps and, in so doing, becoming role-models in the community. This leads to **status** not only in the work context, but also within the community. All research subjects agreed that the OPP contributed to job creation, personal development and poverty alleviation which contributed to the upliftment of the community as a whole. The following interview extracts support the claims presented:

"...many people are employed at the [<i>Sponsor</i>] and then you start looking at each and every individual. It does alleviate poverty because if I'm able to tell you I wasn't employed before, now I'm employed. What if I have a kid there are many people out there who are our colleagues that are parents, they have families so obviously every month they are able to bring home something. So it does alleviate poverty, it also reduces crime..."
"...I think that it has helped a lot of people to be uh employed because immediately when they saw you in the community they will always ask you what's happening with your job and we want to join and then obvious we are going to give them right information and most of them they come and they bring their cv here, they are now working..."
"...we make a difference we make it easier for the community and other people who are walking those that are don't using the car..."

CONCLUSIONS AND RECOMMENDATIONS

From the findings presented above, the following is evident:

- People are in a better position than before they joined the OPP, as many opportunities resulted from the OPP.
- People enjoyed their working environment indicating that beneficiaries are engaged.
- Community development is assisted by income generated and training opportunities available through the OPP.

- Research subjects associate community development primarily with job creation.
- The OPP has had a positive effect on people from underprivileged backgrounds.

A comparison of research subjects' current position with their position before joining the OPP, reveals that the majority of the research subjects, are far better off. This affirms that the intended beneficiaries of this CSR initiative are in fact benefitting from the initiative, as intended by the sponsor. The intention of the OPP, as mentioned, was to help alleviate traffic congestion on the one hand, and on the other to help eradicate unemployment and to give back to local communities. It would seem as though the OPP is indeed succeeding in these regards. The fact that all research subjects enjoy their work indicates meaningful engagement between these beneficiaries and the *Private Company*. This would not be the case if the *Private Company* did not consider the needs of the points-people. Although meaningful engagement exists between the *Private Company* and the beneficiaries, there is no evidence that this takes places between the *Sponsor* and the beneficiary. The change in living context of points-people can be directly attributable to the income they generate. Not only is the OPP allowing individuals to improve their standard of living, but the ability of the bread winner to provide for the extended family enables the family to improve their living standards. This scenario applies to many of the research subjects, and thus the employment of a few individuals within one community can be the catalyst for the development of the entire community. This case shows that from the perspective of the intended beneficiary, job creation is crucial for poverty alleviation as well as community development. Although research subjects cite opportunities for education and training as part of the OPP, they don't link these to community development. It can be reasoned that community development arises from employment only where the employment is meaningful.

CONCLUDING REMARKS

The study contributes to our understanding of how CSR initiatives are experienced by those who are targeted as beneficiaries of these initiatives, which is an angle that is not as prevalent in literature as one would assume. This study has gained an understanding of how the lives of these beneficiaries are affected by CSR initiatives. The findings of this study highlight the point that these initiatives do make a difference. However, to make a meaningful difference, real commitment is required, as in the case of the commitment shown by the *Private Company* in this study. Only through meaningful engagement with the communities or targeted beneficiaries can the contribution of CSR initiatives be maximised for all parties involved, and, in so doing, can CSI truly be viewed as investment rather than a mere tick-box exercise.

REFERENCES

- Babbie, E, & Mouton, J. (2004). *The practice of social research*. Cape Town: OUP.
- Barkemeyer, R. (2009). Beyond compliance – below expectations? CSR in the context of international development. *Business Ethics: A European Review*, 18(3): 273–289.
- Carrol, AB. (2008). A History of Corporate Social Responsibility Concepts and Practices. In: Crane, A.; McWilliams, A.; Matten, D.; Moon, J., and Siegel, D (Eds) 2008. *Oxford Handbook of Corporate Social Responsibility*. New York: OUP.
- Corbett, A & Spencer, P. (2009). Corporate Constitutionalism. *Sydney Law Review*, 31(147): 147-161.
- Creswell, J. (2009). *Research Design: Qualitative, Quantitative, and Mixed Methods Approaches*. London: Sage.
- Fig, D. (2005). Manufacturing amnesia: Corporate Social Responsibility in South Africa. *International Affairs*, 81(3): 599–617.
- Fox, W. & Bayat, M.S. (2007). *A Guide to Managing Research*. Cape Town: Juta.

Freemantle, A. & Rockey, N. (2004). *The Good Corporate Citizen: Pursuing Sustainable Business in South Africa*. Cape Town: Trialogue.

Friedman, M. (1970). The Social Responsibility of Business is to Increase Profits. *New York Times Magazine*. September 13. Issue 33, 122-126.

Garriga, E. & Mele, D. (2004). Corporate Social Responsibility Theories: Mapping the Territory. *Journal of Business Ethics*, 53(1): 51-71.

Hinson, R.E. & Ndhlovu, T.P. (2011). Conceptualising corporate social responsibility and corporate social investment: The South African context. *Social Responsibility Journal*, 7(3): 332 – 346.

Hopkins, M. & Cowe, R. (2004). Corporate Social Responsibility: Is there a business case? *Teach Accounting*, 4(1): 49-55

Jamali, D., Karam, C. & Blowfield, M. (2015). Corporate Social Responsibility in developing countries: A development-oriented approach. *Development Oriented CSR*, 1(1): 8 – 18.

King Committee on Corporate Governance. (2002). King Report on Corporate Governance for South Africa. Parktown: Institute of Directors in South Africa.

Kloppers, P. (2013). Driving corporate social responsibility through the Companies Act: and overview of the role of the social and ethics committee. *Potchefstroom Electronic Law Journal*, 16(1): 166-199.

Lazonick, W & O'Sullivan, M. (2010). Maximizing shareholder value: A new ideology for corporate governance. *Economy and Society*, 29(1): 13-35.

Le Bruyns, C. (2009). Corporate social responsibility and gender justice in South Africa. *International Journal of Public Theology*, 3(2):222-237.

Louw, L. & Venter, P. (2006). *Strategic management: Winning in the Southern African workplace*. Cape Town: OUP.

McWilliams, A. & Siegel, D.S. (2000). Corporate Social Responsibility and Financial Performance: Correlation or Mis-Specification. *Strategic Management Journal*. 21(5): 603-609.

Moura-Leite, R.C. (2011). Historical background of corporate social responsibility. *Social Responsibility Journal*, 7(4): 528-539.

Newell, P. & Frynas, J.G. (2007). Beyond CSR, Business, Poverty and Social Justice: An introduction. *Third World Quarterly*, 27(4): 698-681.

OUTsurance. (2016). *OUTsurance Pointsmen*. [online]. Available from: <http://www.outsurance.co.za/pointsmen/>

Pimpa, N., Fry, S. and Gekara, V. (2012). MNC's and poverty alleviation: Approaches and Challenges. Proceedings of the 2012 of Academy of Management Conference held in Boston, USA.

Ramlall, S. (2012). Corporate social responsibility in post-apartheid South Africa. *Social Responsibility Journal*, 8(2): 270 – 288.

Seidman, G.W. (2003). Monitoring multinationals: Lessons from the anti-apartheid era. *Politics & Society*, 31(3): 381-406.

Slabbert, J.A., Prinsloo, J.J., Swanepoel, B.J. & Backer, W. (1998). *Managing Employment Relations in South Africa*. Cape Town: Butterworths.

Spicer, M. (2002). Big Business makes a big impact. *The Business Trust*, 48(1): 47-51.

World Bank. (2006). *Beyond Corporate Social Responsibility: The Scope for Corporate Investment in Community Driven Development*. Available from: http://siteresources.worldbank.org/EXTSOCIALDEVELOPMENT/Resources/244362-1164107274725/3182370-1164201144397/Beyond_CSR_CDD_2006.pdf

ⁱ This intermediary wishes to remain anonymous

ENVIRONMENTAL IMPLICATIONS OF ARTISANAL SANDSTONE MINING: A CASE STUDY OF AN ARTISANAL SANDSTONE MINE IN QWAQWA SOUTH AFRICA

Moukita Koumba, John Francis Agwa-Ejon and Anup Pradhan
University of Johannesburg, South Africa

ABSTRACT

Over the past year, environmental awareness has become an important issue in society. Realization that human activities have adverse impacts on the environment and human health has encouraged academicians to develop sustainability tools to monitor, control and improve the environmental profile of products and processes. Mining in all its forms especially in Southern Africa is an activity that is generally perceived as being extremely damaging to the environment. This paper reports the results obtained from a life cycle assessment study undertaken in an effort to determine the extent to which artisanal sandstone mining affect the environment. The study was conducted in accordance with the standards of the ISO 14040 series. With the functional unit being 1 ton of sandstone produced, and the system boundaries being the phases of extraction, transportation and processing, the results showed that the most impacting phase was related with the transportation phase, and that mining practices had adverse effects on miners' health. Possible improvements could be the adoption of mechanized mining process as well as a more safety and protection equipment.

Keywords: sandstone, artisanal mining, LCA, improvements, QwaQwa.

INTRODUCTION

Despite the increasing adoption of sustainable thinking in the mining sector, ASM is still very much left behind when it comes to improving their environmental performance. This is mainly due to the fact that this sector is still for most part highly informal and that there is no way to effectively regulate their activities and insure the adoption or application of mining policies and regulations that seek to minimize the impacts of mining on the environment. This study is undertaken in an effort to promote sustainability in the artisanal mining sector by determining how this sector affects the environment and in providing recommendations that would encourage ASM stakeholders to be active participants in the efforts towards sustainability in mining.

LITTERATURE REVIEW

Mining in general plays a major role in the world's economy. Whether large scale or small scale, this industry is mostly perceived as extremely damaging to the environment because of the large quantities of waste and pollutant agents emitted, the adverse impacts on human health, the depletion of non-renewable resources and the land and water degradation, that are associated with mining operations (Durucan et al., 2006). Over the past years, the mining sector has made significant efforts to improve their environmental performance and engage in more sustainable practices (Ditsele, 2010). One way to do this has been through the adoption of environmental assessments tools or indicators that help assess the environmental impacts of a product, a process or an activity and

identify areas that could be improved to minimize the said impacts (EPA, 2006). The life cycle assessment (LCA) methodology has emerged as one of the tools that could be used to make this task achievable.

Life cycle assessment is a tool that provides a comprehensive assessment of the environmental burdens of a product or system from the beginning to the end by compiling and evaluating its inputs, outputs and potential environmental impacts throughout its life cycle (Guinee et al., 2002). Since so many products directly or indirectly derive from mining, the use of LCA in mining is extremely important because it is essential for this industry to provide environmental data associated with their activities so that the full spectrum of environmental burdens associated with the use of product can be understood (Lesage et al., 2008). A look at the literature shows that the mining industry has in some instances been up to the challenge. Various studies that deal with the use of LCA to analyze the environmental impacts of mining activities are available and they cover a wide range of minerals, resources and impacts categories (Awuah-Offei et al., 2011). Despite this, the adoption of LCA by the mining sector is still quite limited and faces many challenges including:

- The fact that the base for collection (functional unit, system boundaries etc.) can differ from one study to another.
- Or the fact that generic databases cannot even address site-specific conditions and impacts.

These challenges sometimes make the use of readily available mining LCIs unhelpful. The best option in many mining LCAs would be to collect data directly from the mines but this is often a difficult task as mining organisations often have reservation when it comes to disclosing environmental information related to their activities (Awuah-Offei et al., 2011).

Despite the visible efforts of the mining sector to decrease their adverse impacts on the environment, the contribution of ASM to sustainable development and mining is still not established (Dreschler, 2001). For most part, this sector is still perceived as highly unsustainable because of its high environmental costs and poor health and safety records (Hentschel et al., 2003) and the fact that there is no way to ensure that artisanal miners follow policies and regulations on mining and sustainability. Hentschel et al. (2003) and Buxton (2013) also mentioned that most international standards organisms that deal with mining policies and sustainability do not mention ASM.

LCA OF ARTISANAL SANDSTONE MINING RESULTS

In this study the environmental impacts of artisanal sandstone mining in the QwaQwa area, South Africa, using the primitive mining methods are analyzed by applying the general principles of the life cycle assessment methodology as defined by the ISO 14040 series.

Methodology

The LCA methodology follows the requirements of the ISO standards under the 14040 series and is divided into four main phases:

1. **Goal and scope definition:** defining the purpose of the study, the target audience, the intended use of results, the system boundaries, functional unit and assumptions.
2. **Life cycle inventory analysis (LCI):** recording and quantifying the inputs (energy, water, raw material and any other type of resource) and outputs (atmospheric emissions, waterborne emissions, solid wastes and other type of environmental burdens) of a product system. In order to be effective, all stages of the product life cycle (as defined by the boundaries) must be included.
3. **Life cycle impact assessment (LCIA):** this stage is performed based on the outcomes of the life cycle inventory. LCI results are further processed in order to determine the potential environmental impacts and are assigned to preselected list of impacts categories.
4. **Life cycle interpretation:** In this phase, the results of the life cycle inventory and life impacts assessment are evaluated and analysed. Major issues are identified and recommendations that are consistent with the goal of the study are made.

All environmental effects were given in quantitative measures. The SimaPro Software was used to analyse all data collected. Two assessment methods were used for impact assessments, namely: IPCC 2013 GWP 20a and IMPACT 2002+.

Description of ASM mining and processing

The following mining and processes are based on the information collected from the artisanal mine in QwaQwa, Free State province in South Africa.

5. **Extraction:** The mining phase requires the removal of the layer of vegetation in an area where the sandstone deposit has been identified. Once the area is ready for extraction, the miners use hammers to create cracks on the sandstone deposit; the cracks are then enlarged by putting chisels between the cracks and hammering until the block separate from the deposit. It is important to note that because of the type of mining method used, waste or overburden is significant.

6. **Transportation and processing:** The blocks of stones that are considered fit for marketing are loaded into the truck and then transported to the warehouse for processing. In this case the mine is situated 12 km away from the warehouse. The mine uses a cutting blade machine to further process the stones into readily usable products (bricks etc.). The cutting machine is electricity powered and uses water to dissipate the heat that is generated when the stones are being cut.

1. Definition of Goal and Scope

Goal definition: The objective of the study was to conduct an LCA of the process of artisanal sandstone mining and processing in the QwaQwa area, South Africa. The study was undertaken in an effort to assess the impacts of that activity on the environment. It took into consideration all stages of artisanal sandstone from cradle to the mine gate. Other objectives of the study included the following:

- Identify the different processes in artisanal sandstone mining and collect relevant data on energy and material inputs.
- Conduct an inventory assessment of inputs and emissions and determine contribution to selected impact categories.
- Identify areas to improve environmental performance and suggest improvement measures.

Scope definition: The study did not take into consideration the processes, energy and materials use and emissions during the exploration and development phase of the mine as well the transportation of the final product (processed sandstone) to the consumers. The phases considered for this LCA analysis were the exploration phase and the processing phase including the transportation of the stones to the warehouse where it is stored temporary before further processing to the customer specification. (See figure 1).

The functional unit (FU) for the study was 1 ton of sandstone processed at the mine warehouse.

2. Life Cycle Inventory

The life cycle analysis phase has a great impact on the reliability of the LCA results and the relevance of the improvements suggestions. In order to avoid unreliability, data collection should be performed according to well define code such that comparison of results could be made with other studies and existing data. For the purpose of this study data were collected directly from the mine and where information was not available assumptions were made. The summary of data for the production of one ton of sandstone is given in table 1 below.

Table 1: Material Used and Energy input and output

Inputs from techno sphere	
Electricity (kWh)	1.49
Diesel (litres)	2.16 (one way)
Energy input (MJ)	172.4
Inputs form nature	
Land area	
Sandstone kg	1 300
Water (litres)	12
Coal (kg)	0.54
Emissions	
CO ₂ (kg)	13.164
CH ₄	n/a
N ₂ O	n/a
SO _x (as SO ₂) (kg)	0.01632
NO _x (as NO ₂) (g)	0.0062
Product output	
Sandstone bricks (t)	1.00

3. Impact Assessment and Interpretation

The results of the LCI were analyzed and the findings were interpreted as follows:

Energy use: artisanal sandstone mining uses very little energy when compared to large scale mining. Most energy consumption results from the use of fossil fuel (diesel) during transportation, while the processing accounts for less than 4% of total energy use for the production of one ton of sandstone figure 1 below.

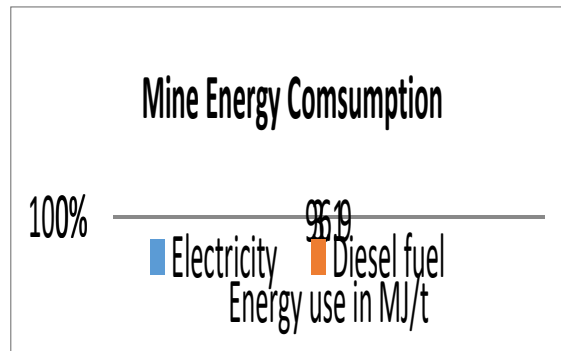

Figure 1: Contribution of each energy sources to total energy use.

Working habits and human health

Personal interviews performed on the miners showed that most of the respondents had suffered from musculoskeletal problems including back pain and muscle pain. This is due to the lack of sophisticated equipment that forces the miners to rely on their own force to extract and carry the stones. The other significant health issue that was observed was of a respiratory nature and related to the inhalation of dust particles table 2. Skin infection was also mentioned as an health issue faced by the miners.

Table 2: Summary of data collected linked to Miner’s health issues

Numbers of respondents			
31	Respiratory diseases or problems	21	68%
	Musculoskeletal problems	25	80%
	Skin infection	15	48%

Emissions

Contribution to emissions of carbon dioxide (CO₂) gases only occurred through the use of coal generated electricity for processing and diesel fuel for transportation. Most of the CO₂ emitted during came from the transportation phase with 11.664kg of CO₂ emitted to transport the stones from the mining site to the warehouse, whereas only 1.50kg of CO₂ was emitted as a result of electricity use.

Transportation of the stones from the mining site to the processing warehouse was responsible for the emission of most of the sulphur dioxide (SO_x).

NO_x (nitrogen dioxide) emissions were mainly attributed to coal generated electricity usage during the processing phase.

IMPACTS CATEGORY

The SimaPro Software for LCA was used to analyse the results of the inventory analysis. Two assessment methods were used for impact assessments, namely: IPCC 2013 GWP 20a and IMPACT 2002+.

The network for the production of artisanal sandstone is shown in the figure 2 below.

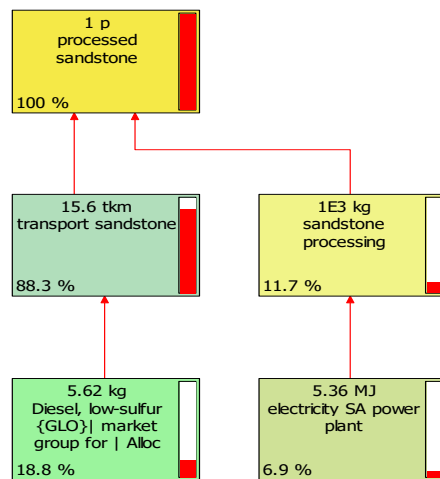

Figure 2: Process network diagram for artisanal sandstone mining.

1. Global Warming Potential

Global warming potential impacts are associated with the release of carbon dioxide during the transportation and processing phases. The transportation phase with the use of a fossil fuel powered vehicle is the biggest contributor to total emissions CO₂ emissions (88%) (See figure 2).

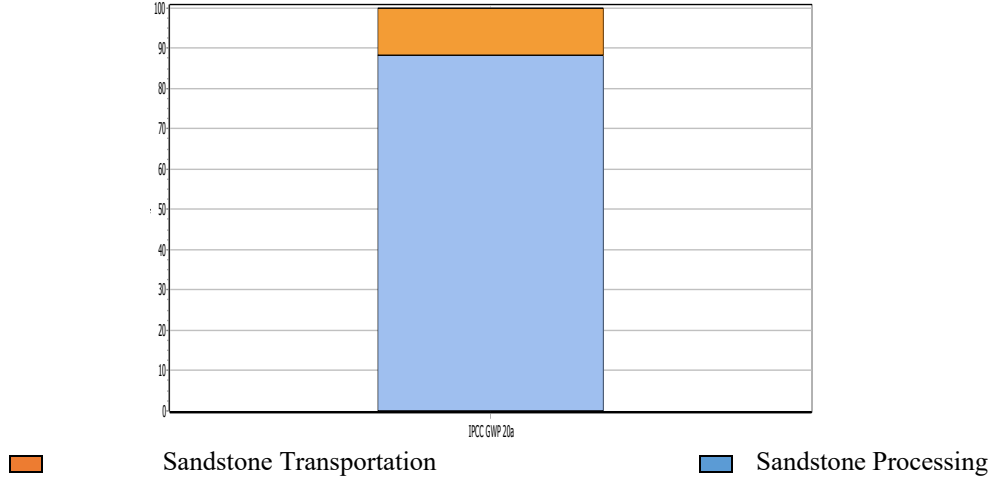

Figure 3: IPCC global warming potential for the last 20 years.

To assess the contribution of each process/phase to climate change; one can refer to the results of global warming potential because the contribution of each phase to climate change is similar to the contribution that they have for global warming.

2. Ozone layer depletion:

Ozone layer depletion solely results from the transportation of the uncut sandstone pieces to the warehouse during which hydrocarbons are emitted during the combustion of the fuel in the truck (see figure 4).

3. Acidification:

The transportation phase contributes the highest to acidification because of the amount of Sulphur dioxide emitted when the diesel fuel is burned in the truck. Contribution of the processing phase to this impact is due to the use of electricity and the emission of Sulphur dioxide when the heat generated by the combustion of coal is converted into energy (see figure 4).

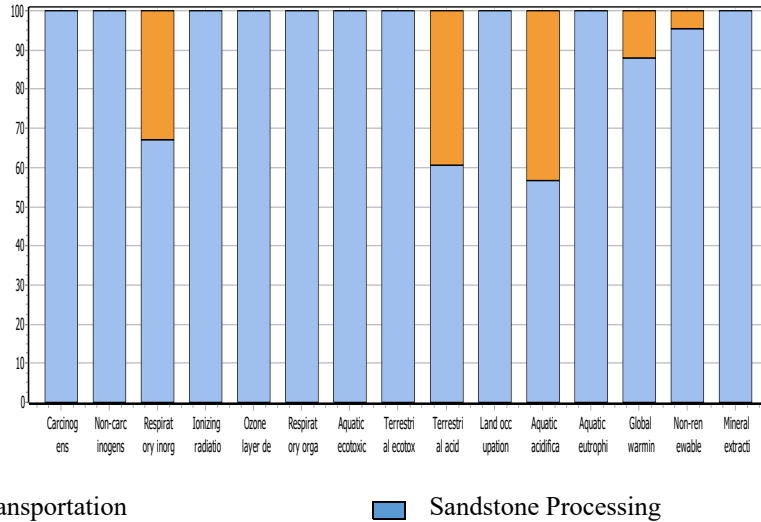

Figure 4: results of characterization.

4. Non-renewable resource use: Sandstone itself does not fall into the category of non-renewable resource because it is a resource that is virtually inexhaustible (natural bedrock underlying all continents). Non-renewable resource use is mainly due to the use of fossil fuel (i.e. diesel) for transportation and coal generated electricity for stone processing.

Normalization of the results is depicted in the figure 5, and shows to what extent each phase of artisanal sandstone mining contributes to human health, climate change and non-renewable resource use impacts.

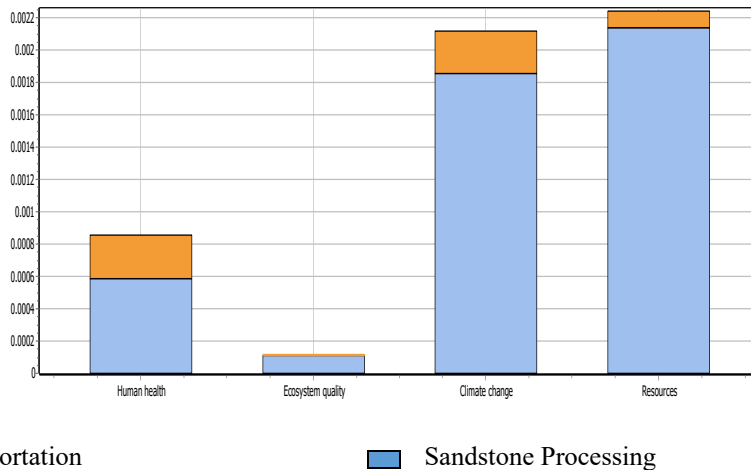

Figure 5: Normalization of the results.

RECOMMENDATIONS

Working habits and human health

Miners have complained of various health issues that are associated with the working practices at the mine. Respiratory diseases associated with dust inhalation can be reduced by making the use of nose dust masks compulsory. Tiredness and musculoskeletal were also cited as major health issue because miners heavily rely on their personal strength and energy to extract the stone and for handling. The adoption mechanized mining process would significantly reduce the physical exertion put on the miners and the resulting health effects. Another benefit of adopting mechanized extraction process would be the reduction of stone waste, thus increasing the mine productivity. Although less not many respondents acknowledged that the hammering noise was an issue, the distribution of ear protector to the miners would be advised.

Land use

Not many changes could be adopted to reduce the impacts of the mining activities on the land without impacting the productivity of the mine (reducing the extraction area also means reducing the amount of rock extracted). The major concern in land use is land rehabilitation (ensuring that land gets returned to its previous state once the mine close operations). Although the mine does to a certain extent engage in land rehabilitation (e.g. waste rock is used to fill up holes created by erosion and extraction), there is still a lot that could be done to minimize the effects of mining on the land. Hydro seeding can be used to revegetate areas where vegetation would have been removed for extraction.

Energy use

The study showed that diesel fuel, used for truck engine during transportation, was the main energy source in artisanal sandstone mining, followed by electricity for stone processing. The use of fossil use is directly linked to ozone layer depletion, global warming and climate change; improvements in energy use can address these three impacts categories. Reducing impacts associated with consumption of diesel fuel could be resolved by the adoption of the alternative biodiesel and also by increasing the mine productivity as small scale operations are often inefficient in the use of energy.

REFERENCES

- Awuah-Offei K. & Adekpedjou, A. (2011). *Application of life cycle assessment in the mining industry*. The international journal of Life Cycle Assessment. 16 (1): 82-89.
- Buxton. A. (2013). *Responding to the challenge of artisanal and small-scale mining. How can knowledge networks help?* International Institute for Environment and Development (IIED), London. [Online] Available from: <http://pubs.iied.org/16532IIED.html> [Accessed 2015/12/21].
- Ditsele. O. (2010). "*Application of life cycle assessment to estimate environmental impacts of surface coal mining*". Masters theses. Paper 4801.

Dreschler, D. (2001). *Small-scale Mining and Sustainable Development within the SADC Region*. Mining, Minerals and Sustainable Development N° 84. International Institute for Environment and Development (IIED), London. [Online] Available from: www.iied.org/mmsd [Accessed 2015/08/22].

Durucan, S. Korre, A. & Munoz-Melendez, G. (2006). *Mining life cycle modelling: a cradle-to-gate approach to environmental management in the minerals industry*. Journal of Cleaner Production 14 (2006) 1057-1070. Online access: www.elsevier.com/located/jclepro (2015/05/05).

EPA (2006). *Life cycle assessment: principles and practices*. U.S Environmental Protection Agency (EPA), Cincinnati. [Online] Available from: <http://www.epa.gov/ORD/NRMRL/lcaccess> [Accessed 2015/05/04].

Guinée, J.B., Gorrée, M., Heijungs, R., Huppes, G., Kleijn, R., Koning, A., Oers, L. Van, Wegener Sleeswijk, A., Suh, S., Udo de Haes, H.A., Bruijn, H. De, Duin, R. Van & Huijbregts, M.A.J. (2002). *Handbook on life cycle assessment. Operational guide to the ISO standards. I: LCA in perspective. IIa: Guide. IIb: Operational annex. III: Scientific background*. Kluwer Academic Publishers, ISBN 1-4020-0228-9, Dordrecht, 2002, 692 pp.

Hentschel T., Hruschka F & Priester M (2003). *Artisanal and small scale mining: challenges and opportunities*. Mining, Minerals and Sustainable Development N° 70. International Institute for Environment and Development (IIED), London. [Online] Available from: www.iied.org/mmsd [Accessed 2015/08/18].

Lesage, P., Reid, Margni, M, Aubertin, M. & Deschênes, L. (2008). *Use of LCA in the mining industry and research challenges*. Online available from: http://www.academia.edu/download/37931280/G3-P_Lesage_II.pdf

ANTI-CRISIS MONETARY POLICY AND DEFLATION

Vladimir K. Krylov & Anna N. Zhilkina
State University of Management, Russia

ABSTRACT

The article is devoted to questions of deflation and its role in anti-crisis monetary policy. The work deals with the consequences of the impact of inflation targeting and other forms of targeting monetary policy on the economic situation of a country and its prospects for economic growth.

Keywords: State Monetary Policy, Targeting, Deflation

INTRODUCTION

In recent years, many of State Central Banks adheres to the inflation targeting regime. Inflation targeting provides for setting a benchmark in the form of an index of consumer prices and the use of all instruments of the Central Bank in order to achieve the goal. At the same time, as the main tool that affects the price level, the interest rate is considered, regardless of its style of the economy as a whole. Priority of price stability is understood as a sufficient condition for solving all other economic problems by means of an automatically functioning market competitive mechanism. At the same time, clear benchmarks for inflation are seen as a factor ensuring a reduction in inflationary expectations, and thus contributing to the development of domestic long-term investments and economic growth.

STATE SITUATION IN THE WORLD

Last time non-monetary factors of inflation play an exceptionally important role: pricing of monopolies, administrative intervention in the process of pricing, criminalization of the economy, and so on. The fight against inflation due to high interest rates entails complications on the way out of the economic recession. As a result, the economy falls into a stagflation funnel; it is very difficult to get out of it using the inflation targeting regime (Dictionary of the economy 1998).

Moreover, an excessively zealous fight against inflation carries with it an even greater danger - deflation. When the purchasing power of money starts to grow, it means that there is an absolute decline in prices. The economy in this case is in a deflationary environment. Deflation, as a certain state of money circulation and the economy in general, should be distinguished from the deflationary policy, which is the implementation of measures aimed at reducing prices, but not necessarily reducing them absolutely.

In the XIX century and the first third of the 20th century the dynamics of prices were mostly cyclical. During the crises, prices fell, in the ascent phase they grew. Thus, the periods of deflation were followed by periods of inflation. At the same time, as a rule, economic crises were accompanied by monetary crises, which could break out on their own. Monetary crises acted as crises of the monetary system and manifested themselves, first of all, in the form of shortage of means of payment, bank failures of banks, credit cuts. After the 2nd World War, acute financial crises were virtually eliminated. F. Hayek called the twenty-five-year period after the Second World War a period of great prosperity. "By eliminating the automatic brakes that were in effect before (namely the gold standard and fixed exchange rates), we are really doing well in maintaining full employment (and even over-employment), created through crisis expansion and prolonged, at the expense of open inflation." (Samuelson & Nordhaus 2007,

p.58). Therefore, the center of gravity of economic policy has shifted quite objectively to the solution of the problem of combating inflation.

However, the beginning of the XXI century was marked by the emergence of deflationary tendencies in developed countries, which found its manifestation at near-zero inflation rates and even a number of cases of negative interest rates. At the same time, economic growth showed minimal values.

US SITUATION

The US introduced quantitative easing monetary policy, which began to collapse in 2013 after reaching the unemployment rate of 6.5%. The policy of mitigation lasts long and carefully. In March 2017, the Fed raised the rate by 0.25 percentage points. up to 0,75-1%. At the same time, this year two more increases are possible up to 1.4% and only by the end of 2018 to 2.1%. Such a policy is connected with the fact that inflation in January 2017 approached the Fed's target of 2% to 1.9%. At the same time, in February, unemployment fell to 4.7%, and wages also increased a little bit. The press notes that the optimism of business and consumers is due to the fact that the new president, Trump, will reduce taxes and increase budget expenditures. The Fed raised its forecast for economic growth to 2.1%, while unemployment and inflation reached target values of 4.5% and 2%, respectively. (Moiseev 2004, p.5)

If in 2016 the Fed refrained from increasing the interest rate, other central banks reduced them or expanded bond purchase programs, trying to fight deflation and stimulate economic growth. Bank of Japan in January 2016 lowered interest rates below zero, the European Central Bank (ECB) in March of the same year lowered rates and expanded the program for the purchase of assets. In the euro area, by the end of 2015, the aggregate price level has become absolutely negative, in fact it meant the onset of deflation, although the process of price reduction began here in 2013. The ECB in response to this began active monetary incentives to accelerate economic growth and inflation. By early 2017, the ECB had acquired assets of more than 1.5 trillion euro, and only now in February 2017 for the first time since January 2013. The inflation rate has reached the target of 2%.

JAPAN SITUATION

Especially in terms of deflation, the situation in Japan is indicative. The fact is that as early as 1989, the Bank of Japan raised rates and bubbles formed in the 80s. In the stock and real estate markets burst. Since then, average annual GDP growth has not exceeded 1% and recessions have periodically occurred, and in the late 1990s, Prices began to fall. As noted by D. Lyons and M. Inada: "It's been a quarter of a century since the bubble burst in the local real estate market, and during this time a whole generation of economical people grew up in the country who saw nothing but economic problems, stagnation of salaries and Deflation ". (Eatwell et al 2004, p. 5) Therefore, the general opinion about the preservation of the deflationary situation in the economy has taken root. The representative of the British company HSBC asserts that "even with the help of radical politics, it is difficult to change the deflationary type of thinking. I'm ready to argue that Japan will remain in this state for many more years. " (Eatwell et al 2004, p.5)

In April 2013, the program of stimulating the economy began to be implemented. As a result, which infused trillions of yen into it, interest rates were reduced to negative values. For a short period, economic growth accelerated and prices began to rise, but in 2016 the situation in Japan could again be described as deflationary. In recent months, inflation has become positive, but economists associate this with external causes, and not with changes in the internal economic situation. Companies and consumers in the opinion of economists do not increase costs, as they are used to deflation and are waiting for the continued decline in prices. In addition, it is assumed that about zero rates scare people, forcing to save money for a current day, rather than spend. (Eatwell et al 2004, p.5)

CONCLUSION

Of course, the situation in many other countries is different. As for deflation, it should not be thought that a similar situation in every economy is absolutely impossible. The pursuit of a decrease in inflation carries with it the risks of deflationary trends.

REFERENCES

Dictionary of the economy. COLLINS.-SPB: The School of Economics, 1998.

Economic theory / ed. Eatwell, J., Milgeyta, M., Nyumena, P.: INFRA-M, 2004.

Glazyev, S.Y. (2015). *On the inflation targeting* / Problems of Economics, №9.

Mishkin, F.S. (2006). *Economic theory of money, banking and financial markets.*- M.: "I.D.Vilyams» LLC.

Moiseev, S.R. (2004). *Inflation: a modern view of eternal problemu.*- M LLC "Market DS Korpareyshen".

Samuelson. P.A., Nordhaus, V.M. (2007). *Economics* LLC "I.D.Vilyams".

Stiglitz, J. (2008). *Tests statement a reality* // 16.05.2008.

Ulyukayev, A.V. (2009). *Modern monetary policy: problems and prospects.* M: "Delo" ANE.

ENTREPRENEURSHIP POLICIES VERSUS PRACTICE: A GREAT DIVIDE FOR TOURISM ESTABLISHMENTS IN RURAL SOUTH AFRICA

Marcia Lebambo
Tshwane University of Technology, South Africa, Pretoria

Richard Shambare
University of Venda, South Africa, Polokwane

ABSTRACT

The mainstream entrepreneurship literature hardly distinguishes between urban and rural entrepreneurship. Because of this misnomer, the dynamics of rural entrepreneurship are not adequately understood by policymakers. This is particularly true for rural micro entrepreneurs in South Africa's lodging industry. So, despite South Africa having a battery of entrepreneurship policies as well as capacity development institutions, their power to promote rural entrepreneurship is limited owing to a general lack of knowledge of rural entrepreneurship processes, dynamics, and even challenges. As such, the purpose of this study is to assess the state of lodging business in rural South Africa. A qualitative case study design, using in-depth interviews with 15 entrepreneurs and five policymakers – managers from the respective Capacity Development Institutions (CDIs). The study found that, rural entrepreneurs are still confronted by challenges that are not always experienced by their counterparts in urban areas. Neglected infrastructure and poor service delivery continues being a threat to the livelihoods of these businesses. Many areas are still without water, proper roads and access to telecommunication services, resulting in high cost of doing business and lack of investment. Due to lack of access to administrative centres locally and limited awareness of the institutions, a great divide exist between government and rural entrepreneurs. By highlighting the plight of rural entrepreneurs, the paper will be assisting policy makers in of enacting the correct interventions.

Keywords: Rural, policies, entrepreneurship, South Africa, bed and breakfast.

INTRODUCTION

The former South African government owing to apartheid policies systematically excluded and disempowered entrepreneurship ventures among the black population (Department of Trade and Industry, 2004, 2008). To date, the range of enduring legacy issues from the apartheid system continues to undermine economic efficiency and job creation (Department of Trade and Industry, 2014). According to World Bank (2014) South Africa remains a dual economy with one of the highest inequality rates in the world, perpetuating equality and exclusion. The unemployment rate increased to 27.7 per cent in the first quarter of 2017 from 26.5 per cent in 2016 (Stats SA, 2017). Roughly 10.2-million South Africans living in extreme poverty (below the food line) were recorded in 2011 (Stats SA, 2014).

In an attempt to address this economic quandary, accelerate progress and build more inclusive society, the government has introduced numerous policies and strategies to support entrepreneurship in South Africa. The White Paper on National Strategy on the Development and Promotion of Small Business in South Africa (SA, 1995) was the first post-apartheid government policy documented developed for to promote entrepreneurship in South Africa. The Integrated Strategy on the promotion of entrepreneurship underpinned three strategic pillars:

- 1) Increasing financial and non-financial support,
- 2) Creating a demand for the products and services provided by the SMMEs and
- 3) Reducing regulatory constraints.

In line with this action plan, the government established a number of institutions which would be responsible for the implementation of small business development strategy (SEDA, 2016, DTI, 2008). This includes among others, The Small Enterprise Development Agency (SEDA); responsible for providing non-financial support such as training and skills development, business advice and mentorship opportunities; The Small Enterprise Finance Agency (SEFA), which provide financial support to small businesses. The target market is survivalists, micro, small and medium businesses including co-operatives (SMMEs) falling in the following funding gap. The National Youth Development Agency (NYDA), aimed at assisting young South Africans between the ages of 14 and 35 years to start businesses and to finance existing businesses, and National Empowerment Fund (NEF), formed with the purpose of offering financial and non-financial support to black empowered businesses. And in 2012, The National Development Plan, which is a long term plan aimed at doubling the GDP of South Africa by 2030, eliminate poverty and reduce unemployment and inequality. Among other plans of the NDP includes increasing employment from 13-million in 2010 to 24-million in 2030; reduce inequality – the Gini coefficient, from 0.69 to 0.6.. Adding to that, recently, introduction of a new ministry in 2014, to oversee the development of small businesses; Department of Small Business Development (SEDA, 2014; NDP, 2012).

Despite the efforts made by South Africa government to redress the injustices caused by apartheid legacy through entrepreneurship policy interventions; rural entrepreneurs in South Africa are still confronted by a set of different challenges as compared to urban areas. (Ngorora & Mago, 2013). Ndabeni and Rogerson (2005:133) in their research on the challenges of rural tourism in South Africa argue that the South African population of rural small businesses are confronted by particularly intense blockages or challenges that are not always experienced by their counterparts in urban areas. This include appalling backlog in infrastructure services, with limited access to basic services such as water, electricity and telecommunication; weak institutional support provision as compared to urban areas; reduced access to markets due to the negative legacy of apartheid policies which systematically stripped communities of their key assets and spatially marginalised people in remote areas. Chalera (2007) analysed the impact of South Africa's National Strategy for the Development and Promotion of small businesses, the study found that the potential of small business in the rural areas is not fully exploited, owing to poor infrastructure in rural areas (including banking infrastructure). In addition, banks have little to no experience in communicating with micro-entrepreneurs or assessing their operations, and in some rural towns, SMME lending facilities are completely absent (Mago & Toro, 2013). The South African financial and operating environment is not supportive of entrepreneurs in terms of regulations, policies and access to capital (Gore & Fal, 2010). GEM experts rated South Africa negative (under 2) for the time required to obtain permits and licenses, as well as the ease of coping with government bureaucracy and regulations, highlighting the red tape associated with starting up and managing a business.

International studies on rural entrepreneurship also confirms similar challenges of rural entrepreneurship. Haftendorn and Salzano (2003) found that bureaucracy is another factor that hinders rural entrepreneurship. Ahmad and Xavier (2012) indicate factors such as financial assistance, bureaucracy, lack of a proper regulatory system, inadequate system of education and insufficient entrepreneurial training as hindrances to the growth of rural entrepreneurship.

Formal procedures including business license applications discourage rural entrepreneurs. Inadequate application of essential business and management practices hinders the potential of an enterprise (Alasadi & Abdelrahim, 2008). Rural people lack the skills and knowledge on how to use internet which affects rural people's access to important information and opportunities. Acquiring the necessary skill to ensure the survival and success of the business is essential for rural entrepreneurs. Access to markets contributes significantly to the survival of an enterprise. In rural areas local markets are too small to sustain operations of rural entrepreneurs and to promote access to other markets (Lyons, 2003, Lebambo, 2014, Ngorora & Mago, 2013). Rural entrepreneurs also face harassment from state and council police because they often do not have licenses or sometimes operate from "illegal" spaces (Chigunta et al., 2005) due to lack of information they are also often exploited by larger companies or industries. Business role models or mentors appears to have an immense effect with regard to establishing entrepreneurial culture that has a significant role in sharing information and knowledge (Lebambo, 2014). Limited

family business culture (Maphalla, 2009) and lack entrepreneurial role models (are two of the most prominent barriers to rural entrepreneurship development. The presence of role models, mentors or partners would be a decisive element in establishing the individual's practicality level.

TOURISM DEVELOPMENT IN SOUTH AFRICA

Through the National Development Plan 2030 vision, Tourism has been identified along with other key economic sectors such as Manufacturing, Mining and Minerals, ICT, Wholesale and Retail and Finance and Business Service; as important to stimulating the growth of small businesses and advancing the economy of post-apartheid South Africa. Tourism sector in South Africa continues to increase its contribution to the country's Gross Domestic Product (GDP) and job creation. The sector reached an impressive first time highest score of 10 million international visitors in 2013 (Stats, SA, 2014), an impressive growth compared the 50 000 that was recorded in the late 1980s, at the height of apartheid and sanctions against the country (Rogerson & Visser, 2004). In 2011, tourism's contribution to (GDP) was about R252 billion, 8, 6 percent of total GDP. Contribution to employment was estimated at 1, 2 million jobs, an increase from 567,378 jobs that was recorded in 2010. In 2013, Tourism's GDP contribution was R103, 6 billion, an increase from R93, 5 billion in 2012. The industry's contribution to total GDP remained stable at 2, 9 percent for both years, 2012 and 2013. The World Travel and Tourism Council (WTTC) indicates that travel and tourism in South Africa directly employed more people than other key economic sectors such as the mining, communication services, automotive manufacturing and chemicals manufacturing sectors in 2013. This report has since positioned Tourism sector at the center of South Africa's economic agenda.

Coupled with the successful hosting of the FIFA 2010 Soccer World Cup, South Africa is increasingly becoming a tourism destination of choice and its performance continues to grow well compared to other countries. This was presented through a competitiveness study undertaken by South African Tourism in 2010 that compares and benchmarks its positioning and performance relative to those of key competitors, such as Australia, the United States, Kenya, Thailand, and Brazil. In the survey, South Africa maintained the highest growth in tourism's GDP contribution at 13 percent, compared to Australia's 12 percent. Three year later, in 2013, the United Nations World Tourism Organisation (UNWTO, 2013) ranked South Africa second in the top 10 African destinations, with over 9.5 million international arrivals.

The most visited provinces in South Africa were Gauteng, Western Cape and Mpumalanga. The figures presented clearly indicates the growth in tourism that consequently presents opportunity for tourism businesses such as lodging to develop and become sustainable. However, in spite of the sector's highly impressive growth and contribution to the economy of South Africa, entrepreneurs in the rural areas are confronted with many challenges and battling to survive, a setback that changes the image of tourism in South Africa and further contradicts the entrepreneurship policy intentions of government.

This is particularly true in Mpumalanga where rural lodging enterprises are battling to make meaningful profits, growth and business sustainability, forcing many business to shutdown, despite the number of natural tourist attractions found in the province. These includes the world's most visited parks such as the Kruger National Park, with over one million visitors a year, the God's Window and the Bourke's Luck potholes on the Panorama route. Whilst the province host over 1.3 million tourists visiting annually (Tourism SA, 2014), one could conclude that the impressive figure automatically provides an opportunity for rural lodging businesses in the province to increase, become profitable and sustainable, however, the opportunities that tourism growth presents are yet to be realised by rural lodging entrepreneurs in the province. Williams (1975) defines rural areas as tourism destinations with qualities, which are absent from urban life, which attracts tourism development for rural areas. Lane (1994) corroborates Williams' definition by associating rural tourism with an experience which encompasses a wide range of attractions and activities that take place in agricultural or non-urban areas. Its essential characteristics include wide-open spaces and opportunities for visitors to directly experience agricultural and natural environments. Rural tourism occurs in the countryside or in small rural settlements and is made up of ecological elements, referred to as eco-tourism, as well as cultural and traditional elements present in the rural areas (Reid 2000). Rural tourism is fundamentally based on some form of natural resource (Mearns, 2003) and as such nature-based tourism (eco-

tourism) a subset of tourism is touted as a solution to the problem of rural-underdevelopment (Viljoen & Naicker 2000).

The rural population in South Africa is estimated at 38.3 percent (19 million) of the total population of 54 million (Stats SA, 2014). In Mpumalanga province however, the rural population figure is even more than half of the province's total population with an estimated 61 percent of the total population (4, 229, 300) living in the rural area. Rural environments are confronted with different obstacles from urban context (Durr, Lyons & Liechtenstein, 2001). These areas are characterized by low level of employment, lack of skills and low level of education, poor housing conditions, low earnings and a generally limited service delivery such as infrastructure development, which in turn discourages entrepreneurship development (Koch; 1993).

METHODOLOGY

The qualitative research methodology was adopted in this study. Qualitative methodologies explore research problems in as much detail as to achieve in-depth rather than in-breadth knowledge (Silverman 1998; Yin, 2003). Yin (2003) advises that when the phenomenon under review is a real-life problem then a case study method is deemed more appropriate. In total, 20 cases were used to collect data (15 tourism lodging enterprises and 5 government business support institutions). Consent from participants for their voluntary participation in the study was obtained. Digital voice recorders were used to capture the interviews. The recorded interviews were transcribed for subsequent analysis.

Following recommendations on qualitative analysis by Creswell (1998) the qualitative data analysis (QDA) software ATLAS.ti was used to analyse the transcribed interviews. Both discourse and content analyses using open coding and theme categorisation were used. This was followed by within-case and cross-case analyses utilising ATLAS.ti analysis tools including the Query Tool, Code Co-occurrence Explorer, and Codes-Primary Document Table.

RESULTS

The study used two research questions to establish the role of policies in the development of micro bed and breakfast establishments in rural South Africa. (1) *What is the state of micro rural tourism lodging enterprises and* (2) *what is the role of policies in the development of micro rural lodging enterprises.*

The study find that there are four typologies of micro lodging businesses in rural Mpumalanga Province of South Africa with similar characteristics of four types of birds, indicated below:

1. The Eagles entrepreneurs
2. The Eaglets entrepreneurs
3. The Owls entrepreneurs
4. The Penguins entrepreneurs

1. The Eagles: represented by Case: 3, 4, 12, 15, 13

The Eagles entrepreneurs are male professionals with university qualifications in different fields. Have multiple businesses and use the B&B as an investment for the future. Highest number of rooms and variety of services. Customers are not limited to accommodation only, but services such as conference venues, multipurpose hall and kiosks. Uses effective marketing strategies such as E-Marketing and active in the running of the business. Entrepreneurs in this category are the trendsetters, the risk takers and the big investors. The other services offer a great opportunity for the business to receive a third stream income that can be used to subsidise the business.

2. The Eaglets: represented by Case 06, 02

Contrary to the Eagles, the Eaglets are female owned B&Bs. The Eaglets possess all the features similar to the Eagles, the only difference is that they have lower number of beds. On average four beds, limiting the number of customers the B&B can lodge a day. However, the Eaglets stay in the properties, unlike the Eagles who are remote. Giving the Eaglets an advantage of know the ins and outs of the business and daily interaction with customers. The only advantage Eagles have over Eaglets is the number of beds and the capacity of other facilities such as kiosks, multipurpose halls.

3. The Owls: represented by Case: 1, 14, 9, 7

Contrary to the former two, the Owls B&B are operated by families (married couples) who stay in the B&B and who are often assisted by their children. Regarding bossiness features, Owls are average in beds and services. They offer only bed and breakfast no other services. Whilst they are suited for the definition of a B&B (bed and breakfast), the lack of other services pose as a threat against their counterparts who are using variety of services to attract more customers. This group of B&s is suitable for small group of visitors who prefers a private set up.

4. The Penguins: Case 8, 10,11,5

They are characterised by poor services (offers bed only), low capital investment, poor marketing strategies depended on referrals in the community. However, the have higher number beds and male owned: The Penguins are more concerned with quick cash to get them through the day. Contrary to the other three categories, these group of entrepreneurs use the B&B as the main source of income. Despite offering a higher number of beds, average 8 beds, this group of B&Bs are operating at the barest level of survival. Factors identified as potential threat to the growth of this category include lack of effective marketing strategies such as the use of the Internet, offering only accommodation (no breakfast and other services) and lack of skills and mentorship to operating a business such as a B&B.

RURAL B&B MATRIX

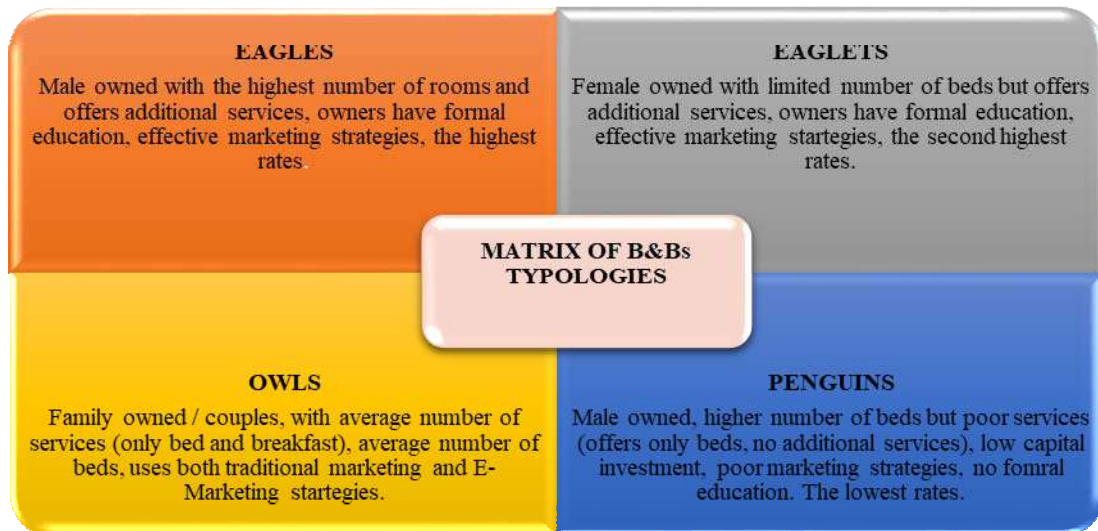

Figure 1.1 Matrix of rural micro B&Bs typologies
Source: Developed for the purpose of the study.

With the second research question, “*how have entrepreneurship policies influenced the development of micro rural lodging enterprises*” five entrepreneurship policy imperatives (1) admin and finance (2) training and skill acquisition (3) legal and regulatory framework (4) markets and (5) infrastructure development, were used to answer the question. The study found the state of entrepreneurship in rural Mpumalanga to have mixed fortunes. Because of its geographical location, rural Mpumalanga is like a double-edge sword. On the one hand, the unavailability of infrastructure makes accessibility of basic services such as water, roads, telephones, internet, and electricity difficult. On the other hand, it is this non-urban remote setting (i.e., bundu) that is the reason why Mpumalanga is such a big tourist destination. The challenge, however, is that the lodging business owners seem to be battling with navigating this entrepreneurial environment. The consequences of neglected infrastructure and poor service delivery are high costs of operating a business and less business investment in rural areas. Furthermore, results suggested the existence of a distinct typology that consists of four variants of micro lodging businesses. Given that the businesses operations and circumstances vary significantly; it can be concluded that the current one-size-fits-all government intervention approach is counter-productive.

Perception of government by the entrepreneurs

Overall, the perception of the entrepreneurs towards government’s institutions of small business support was negative. The negative perception resulted from factors such the red tape and bureaucracy in various offices, the cost of doing business, lack of infrastructure development, preference of established businesses over micro emerging lodges, lack of access to information and support.

CONCLUSION

For micro rural lodging enterprises to become sustainable and profitable ventures, government efforts should be directed in developing the infrastructure including the supply of clean water, proper roads and investment in telecommunication technologies to enable business efficiency. There is also a dire need of proper administration systems that will ensure effective and efficient support of business needs such as compliance, funding and general information. Red tape, kickbacks, poor systems on admin, lack of information and availability of offices locally, lack of business management skills continue threatening the viability of lodging businesses in rural Mpumalanga. The stated challenges corroborates GEM (2014) which indicates that inefficient government bureaucracy remains one of the major obstacles to entrepreneurial activity and business growth in the country. Government must also invest in improving the perception entrepreneurs have in the institutions of support. Most of the cases have not been directly in contact with these institutions but due to negative perception they have ruled out the notion that government is there to serve them. They believe that it serve only the connected few. Coupled with poor administration systems that perpetuate kickbacks, they are reluctant to make use of the institutions. National road shows and discourses could be used to positively influence the perception of entrepreneurs regarding the use of institutions. Overall, the three spheres of government National, Provincial and Local government should work towards the same goals with more powers given to the local government to avoid red tape in service delivery.

Gopaul (2006) research on the significance of rural areas in South Africa for Tourism development found that, rural people are willing to participate in tourism for the development of their area as well as for their own, however, owing to lack of proper business infrastructure, information, skills and training, the participation is not pleasing. These results support the findings of Ndabeni and Rogerson (2005) who found that rural tourism in South Africa is dominated numerically by a host of ‘marginal’ entrepreneurs, many of which are informal sector tourism enterprises and functioning at the barest levels of survival. This obliges the government to give policy attention to of national, provincial and local tiers of government in order to improve the livelihoods of these rural tourism establishments.

REFERENCES

- Ahmad, N.H. & Seet, P.S. (2008). Exploring behaviours associated with business failure: A comparative study of SME founder-owners in Australia and Malaysia. Proceedings of the fifth AGSE. *International Entrepreneurship Research Exchange*. 5-8:1073-1081.
- Alasadi, R. and Abdelrahim, A. (2008). Analysis of small business performance in Syria, Education, Business and Society: Contemporary Middle Eastern Issues, 1(1), p. 50-62.
- Chalera, C.S. (2007). *International, Regional and Local Experiences in SMME Development*. Pretoria: University of Pretoria.
- Creswell, J.W. (2007). *Qualitative inquiry and research design: choosing among five approaches*. London: SAGE.
- Department of Trade and Industry (DTI). (2008). Annual review of small business in South Africa - 2005-2007. Enterprise development unit. Pretoria: Department of Trade and Industry.
- Department of Trade and Industry (DTI). 2004. Annual review of small business in South Africa- 2004. Pretoria: Government printer.
- Department of Tourism. (2014). Rural Tourism Strategy. Available from <http://www.tourism.gov.za/AboutNDT/Branches1/Knowledge/Documents/National%20Tourism%20Sector%20Strategy.pdf> [Accessed 15 August 2015]
- Durr, M., Lyons, T.S., & Lichtenstein, G.A. (2000). Identifying the unique needs of urban entrepreneurs: African American skill set development. *Race and Society*, 3, 75-90.
- Gore, A., & Fal, M. (2010). *The entrepreneurial dialogues: state of entrepreneurship in South Africa*.
- Gopaul, M. (2006). The significance of rural areas in South Africa for tourism development through community participation with special reference to Umgababa, a rural area located in the province of KwaZulu-Natal. *Master of Arts. Dissertation, University of South Africa*. Available from: <http://uir.unisa.ac.za/bitstream/handle/10500/2159/dissertation.pdf> [Accessed 12/01/2017]
- Haftendorn, K., & Salzano, C. (2003). *Facilitating youth entrepreneurship, part 1. An analysis of awareness and promotion programs in formal and non-formal educational programmes*. Geneva: International Labour Office.
- Koch, E. (1993). *Interview, consultant, Mafisa, and member of 'friends of Makuleke'*, Johannesburg.
- Lane, B. (1994). "What Is Rural Tourism?" *Journal of Sustainable Tourism*, 2 (1-2): 7-21.
- Lebambo, M. (2014). The adoption of the internet as an advertising medium by bed and breakfast establishments in Bushbuckridge. *M.Tech Entrepreneurship. Dissertation*, Tshwane University of Technology.
- Lyons, T.S. (2003). Policies for Creating an Entrepreneurial Region. Paper presented at *Main Streets of Tomorrow: Growing and Financing Rural Entrepreneurs*, Kansas City, MO, 2002. Kansas City, MO: Federal Reserve Bank of Kansas City, Center for the Study of Rural America.
- Maphalla, S.T. (2009). Perceived Barriers Experienced by township Small, Micro and Medium Enterprises in Mamelodi. *Masters Dissertation in Commerce*, Faculty of Management, University of Johannesburg.

- Mearns, K. (2003). Community-based tourism: the key to empowering the Sankuyo community in Botswana. *Africa Insight*, 33(1) 29-32
- Ndabeni, L., & Rogerson, C.M. (2005). Entrepreneurship in Rural Tourism The Challenges of South Africa's Wild Coast. *Africa Insight*. 35(4) 2006: 130-141
- Ngorora, G.P.K. & Mago, S. (2013). Challenges of rural entrepreneurship in South Africa. Insights from Nkonkobe municipal area in the Eastern Cape Province. *International Journal of Information Technology and Business Management* 16: 1-11.
- SEDA, (2016). The Small, Medium and Micro Enterprise Sector of South Africa. *Bureau For Economic Research*. Research Report (1) available from: <http://www.seda.org.za/Publications/Publications/The%20Small,%20Medium%20and%20Micro%20Enterprise%20Sector%20of%20South%20Africa%20Commissioned%20by%20Seda.pdf>
- Silverman, D. (2000). *Doing qualitative research: a practical handbook*: London: SAGE.
- Statistics South Africa. (2014). An economic look at the tourism industry. Available from: <http://www.statssa.gov.za/publications/Report-04-05-07/Report-04-05-072013.pdf> [Accessed 15/02/2016]
- Statistics South Africa. (2016). Quarterly Labour Force Survey. Available from: <http://www.statssa.gov.za/publications/P0211/P02111stQuarter2016.pdf> [Accessed 20/04/2017]
- South Africa. (1995). White Paper on National Strategy for the Development and Promotion of Small Business in South Africa. *South African Government Gazette* No. 357 of 1995.
- Reid, D.G. (2000). *Eco-tourism development in Eastern and Southern Africa*. Zimbabwe: Weaver Press.
- Rogerson, C.M. (2004). The impact of the South African government's SMME programmes: a ten-year review (1994-2003). *Development Southern Africa*, Vol. 21, No. 25.
- Viljoen, J.H. And Naicker, K. (2000). Nature-based tourism on communal land: the Mavhulani experience. *Development Southern Africa*, 17(1): 135.
- World Bank. (2014 -2015). Rural Population stats. Available from <http://data.worldbank.org/indicator/SP.RUR.TOTL> [accessed 28/04/2016]
- Williams, G. (1975). *The country and the city*. New York: Routledge.
- United Nation (UNIDO). (2003). ECOSOC HIGH-LEVEL SEGMENT GENERAL STATEMENT available from: http://www.unido.org/fileadmin/import/12142_DGGeneralStatementECOSOC_HLS_30June2003.2.pdf. [Accessed: 15 /3/2017]
- Yin, R.K. (2003). *Case Study Research: Design and Methods, 3rd Edition*. Thousand Oaks: Sage Publications

THE AUSTRIAN CASE FOR A CONSUMPTION TAX TO FINANCE THE EUROPEAN UNION

Auke R. Leen
Leiden University, The Netherlands

ABSTRACT

We discuss the proposal of the High Level Group on Own Resources to introduce new means, stemming from production, consumption and environmental policies, to finance the budget of the European Union. We assess the taxes from the perspective of the market economy in general and entrepreneurship in particular. To modern Austrians, the market is a spontaneous evolutionary process of discovery. Based on that perspective a consumption tax is, by far, the preferred tax to finance the Union's budget.

Keywords: entrepreneurship, EU budget, EU VAT, financial transaction tax, modern Austrian economics.

INTRODUCTION

One of the main objectives of taxation is collecting money for the government. In principle it should not influence the market process, except of course if the explicit aim is to stir up the market with a specific tax or Keynesian-based fiscal policy. This paper looks at the tax policy of the European Union (EU) based on the first of these two points of view. At the moment this is the predominant and relevant view. The present budget is too small for anti-cyclical economic stabilization and substantive redistribution (HLGOR, 2016: 6). For ideas on these latter goals of the EU budget, including progressivity in the contributions of the Member States (MS) (HLGOR, 2016, p. 39), see, e.g., the MacDougall Report (1977, pp. 64-65).

Until recently two taxes were discussed for financing at least about half of the budget, based on a proposal of the European Commission (2011a): a financial transaction tax (FTT) and a consumption tax (an EU VAT). More recently, in December 2016, a High Level Group on Own Resources (HLGOR) chaired by Mario Monti that was established in April 2014 broadened the range of candidates for new own resources to nine. Taking the perspective of modern Austrianism, this paper makes the case for one of them: a consumption tax. The results are based on the ideas of Friedrich Hayek and Israel Kirzner in particular.

EU BUDGET REFORMS

When the EU's two predecessors - the European Economic Community and the European Atomic Energy Community - were established in 1958, direct Member States' contributions financed the Union. However, the goal has always been to have independent sources of finance. At the beginning of the 1980s the EU indeed got its own resources: agricultural levies, custom duties and a percentage of a harmonized VAT base. At present, because of a growing budget and dwindling custom duties, the EU is financed for only 30 percent by these so-called traditional own resources. Its main source of revenue consists of direct contributions by the Member States, which pay a percentage of their Gross National Income (GNI) that is 1.23 percent at most. For 2017 the total budget, in commitments, is nearly 158 billion euro or 1.04 percent of GNI.

Direct contributions, however, have a great drawback: they stimulate so-called *juste retour* behavior of the Member States: they look at what they get and what they give to the Union. Expenses with a real added value to the EU as a whole are stifled. Added value is defined as “the value resulting from an EU intervention which is additional to the value that would have been otherwise created by Member State action alone” (HLGOR, 2016, p. 27). One can think of the present needs for migration and security policy, as well as e.g., energy security and a European infrastructure. The bulk of the expenses, almost 80 percent, however, concern agricultural subsidies and income redistribution among Member States (MS). In general, MS tend to favor instruments that improve their net position rather than those with the greatest value added for the EU as a whole.

To curtail the Member States’ focus on their net contributions, the EU wants new, so-called true own resources. The European Commission (2004) or simply Commission (the EU’s executive arm, which proposes and rejects) and the European Parliament (2007) (which exercises legislative and budgetary functions jointly with the European Council) endorse the idea of a European tax. (The Council defines the EU’s overall political direction and priorities. Its members are the heads of state or government of the 28 EU Member States, the European Council President, and the President of the European Commission). As announced in the budget for the European Union that was accepted by the Commission on February 8, 2013, and still on the wish list today (European Commission, 2016), the Union wants to introduce new own resources. The Commission (2011b) selected a financial transaction tax (FTT) and a European VAT as the two most likely candidates. Recently, however, a HLGOR composed of members appointed by the Commission, Council and European Parliament broadened the list to nine candidates by including taxes stemming from production, consumption and environmental policies: (1) CO₂ levy/carbon pricing; (2) Inclusion of the EU Emissions Trading System proceeds; (3) Motor fuel levy; (4) Electricity tax; (5) EU corporate income tax; (6) FTT; (7) Bank levy; (8) EU VAT reformed; and (9) Seigniorage (HLGOR, 2016: 87).

It should be noted here that the new EU VAT is not to be compared with the existing VAT contribution. The latter has nothing to do with the direct VAT revenues of MS. In order to compensate for the regressive nature of taxing consumption, the base for calculating the contribution is currently set at 50% of the GNI of the Member States. Furthermore, with all of the later adjustments and rebates the VAT contribution has become a statistical figure based on a Member State’s GNI. It is a thorn in the side of the Commission. According to the Court of Auditors (the EU’s independent external auditor) “the VAT resource is levied on a ‘virtual’ basis (a harmonized VAT base which may be subsequently capped and takes into account compensation arrangements for the UK) which is complex to the point of incomprehensibility” (European Commission, 2011a).

Another point of note is that an FTT is a tax that impacts financial transactions between financial institutions. For a VAT, however, the aggregate tax base is the sum of all sales by businesses to non-businesses. The latter is a measure of aggregate consumption, which is the reason why it is called a consumption tax. The base is called an R base (for real, to distinguish it from financial transactions). Under an R based tax, sales for goods and services are taxed, and purchases of goods and services are deductible, but financial transactions, including the payment and receipt of interest and dividends, are ignored. This creates an issue with regard to the taxation of banks and other financial intermediaries: it compromises the neutrality of the tax. Competitive distortion and diversion of tax revenue may be the result. Hence, one of the aims of introducing an FTT is to make the sector pay its fair share since it is under-taxed in comparison to other sectors. It is estimated that the sector, because of VAT exemption on financial services, enjoys a tax advantage of about 18 billion euros each year (European Commission, 2011c). The other reason to introduce an FTT is that, in the eyes of the Commission (*o.c.*), the sector contributed to the financial crisis of 2008 and should pay for it.

THE MARKET PROCESS

The two central figures of modern Austrianism are Ludwig von Mises and Friedrich Hayek. Both of them focus on market adjustment processes. Building his theory as Mises and Hayek have done, Israel Kirzner believes that one of the central failures of neoclassical (equilibrium) analysis is that it assumes that equilibrium is actually brought about. The real problem, however, is to describe the possible realization of an equilibrium as the result of “the systematic way in which plan revisions are made as a consequence of the disappointment of earlier plans” (Kirzner, 1962, p. 381). In short, the market process is a “dynamic entrepreneurial-competitive discovery

process” (Kirzner, 1988, pp. 5-6). What drives the market is entrepreneurship; what characterizes it is competition; and the various steps of the process are discoveries.

What is more, the market is an evolutionary spontaneous process of discovery (Hayek, 1988, p. 146): the market order evolves spontaneously without central direction. No central planner is needed, nor even possible. We do have individual economies, a household or an enterprise, which have their goals and given sets of means. We do not have a market economy in the sense of an order that has a single order of ends. The allocational approach to economics, i.e. economics seen as a theory of choice, is inapt for the market order. The market is a network of many interlaced economies; it is not a singular economy (Hayek, 1982, II, pp. 107-8).

Hayek’s insight resembles modern complexity theory. Complexity theory “studies how the interacting elements in a system create overall patterns, and how these overall patterns in turn cause the interacting elements to change or adapt” (Arthur, 2013, p. 2). We are looking at cultural evolution and the adaptive learning that goes on within large organizations. It is a view of the economy as something that is emerging from the interactions of individual agents whose behavior constantly evolves, whose strategies and actions are always adapting.

Since we are living in a complex world we have a fundamental lack of knowledge of all the specific facts that lead to a market order but on whose functioning we depend. The order, a self-maintaining complex structure, is the result of individuals observing certain rules and adjusting them to their specific situation. The market order is “the result of human action but not of human design” (Hayek, 1982, I. p.20). It is a harmony too complicated for individual comprehension. “The curious task of economics is to demonstrate to men how little they really know about what they imagine they can design” (Hayek, 1988, p. 76). The twin concepts of spontaneous order and evolution are the main tools for understanding and coping with complexity.

THE MARKET PROCESS AND TAXATION

How to cope with our fundamental ignorance of the market process? For taxation this means that we have to assess a tax for its ability to promote creative acts of entrepreneurship. In this respect the distinction between risk and uncertainty is of fundamental importance. The first refers to the risk of a known alternative. The main situation the entrepreneur has to cope with, however, has nothing to do with a known uncertainty compared to given alternatives. The entrepreneur first has to come up with those alternatives. He has to come up with a framework of ends and means (Kirzner, 1973, pp. 82-4). Afterwards he can assess the riskiness of the ends and means. The effect of taxation is different for each of these situations: we’re talking about a known uncertainty of “given” means and ends versus a fundamental uncertainty as far as what the means and ends are in the first place. Neoclassical economics hints at the influence of taxation with regard to the first form of risk; Austrian economics hints at the second form of risk. Fundamental ignorance, and hence an ultimate error, is pitted against a situation of given alternatives involving risk (where we do know the probability distribution of incomes attached to each alternative). For the Austrian economist, entrepreneurship is defined as the very perception of the ends-means framework within which allocation and economizing is to take place (Kirzner, 1973, p. 33).

Four reasons why taxing businesses or changing relative prices is wrong

The first reason not to tax an entrepreneur, and hence not to introduce business related taxes such as an EU corporate income tax, an FTT and a bank levy, relates to the entrepreneurial role of spotting a new opportunity that is available (Kirzner, 1985, pp. 93-118). The entrepreneur spots something that we did not even know existed. This is true for the financial as well as the non-financial sector. An error (utter ignorance) in a market economy reveals itself by showing up as an opportunity for monetary profit. This is completely different than speaking of an uninsured idiosyncratic risk. To stimulate the discovery process we have to look at the producer-entrepreneur. We can conclude that any form of taxation that lowers prospective profits hinders the market’s entrepreneurial process of discovery. Profit provides the incentive that inspires entrepreneurial discoveries.

A second reason to exclude the entrepreneur from taxation is that demand is not the desire of the consumer, *i.c.* other traders who buy a product, for a hypothetical product that has not yet been produced. “[T]he

demand that is expressed in the demand curve for a product means the quantities of it that consumers will be prepared to buy, at given prices, when offered the opportunity of doing so” (Kirzner, 1973, p. 178). Consumer sovereignty means that production patterns are dictated by the pattern of consumer demand. To be specific, it means that “production decisions are determined by entrepreneurial anticipation of the patterns of demand that will be evoked by alternative production plans” (*o.c.*, p. 176). Consequently, if the distortions of taxation—the impact on the discovery process—should be minimized, taxes should not be levied on the entrepreneur. He is the first, the *conditio sine qua non*, to come up with something new in the causal market process.

The third reason is that if it is entrepreneurship that we focus on, profits have to be as visible and promising as possible. Entrepreneurship has to be stimulated. It involves fundamental uncertainty in general but also, and of particular relevance in this respect, uncertainty as far as the complexity and instability of the tax code goes: legislative changes and tax court rulings. Often, because of either the sheer size or instability of the tax code, it is impossible to predict the tax consequences of a particular activity. This fundamental uncertainty loosens the entrepreneurial grip on pure profit. Profits or losses arising from tax changes, by a fortunate or unfortunate change in the tax system, take place after the entrepreneur has taken up his position. A potential and in fact superior vision may be highly stifled. We remove much of the incentive—to “purposeful alertness, the alert purposefulness” (Kirzner, 1999, p. 39)—for paying attention to the unknown.

Fourth, Austrians emphasize the division of knowledge and its growth. To Hayek (1945, pp. 519-520), “the economic problem of society [...] is a problem of the utilization of knowledge not given to anyone in its totality.” Entrepreneurial opportunities tend to present themselves within the context of a specific time and place. A decentralized economy allows individuals to act on their entrepreneurial insights, and rewards them for doing so. And since entrepreneurial insights also lay the foundation for additional entrepreneurial insights, the growth process of the economy is sustained. The market system encourages the full use of (decentralized) human knowledge. There is no efficient non-market, e.g., governmental, resource allocation. This was the insight that the Austrians tried to bring to the fore in the socialist-calculation debate that raged during the interwar period of the last century (Hayek, 1949). The debate began with the question, “Is an efficient non-market resource allocation possible?” For the Austrians, market based prices are necessary to signal scarcity, to transmit knowledge and to stimulate discovery. The government cannot be trusted to do this job, i.e. guiding the discovery process by changing the relative preferability of means of production, as is done with a carbon pricing, the proceeds of the EU Emissions Trading System, a motor fuel levy and an electricity tax.

Policy conclusion (1): an EU VAT

Of all of the proposed new own resources, seigniorage, i.e. the revenue of the European Central Bank (ECB) from issuing currency, would be an ideal, in fact *the* ideal candidate. This is because it has no influence on the discovery process whatsoever. However, because of the need for a Treaty change—something that is not required for any of the other tax options—the HLGOR does not really consider seigniorage a serious option for a new own resource. Additional reasons are the volatility of its proceeds and the fact that not all countries participate in the euro area.

What about the other options for new own resources? Taxing pure profit and/or changing relative prices will hamper the market’s discovery process. If profits are lowered (especially since risk is involved), impeding the first one in the discovery process—i.e. the producer-entrepreneur—and relative prices are changed by the central government with unknown consequences, discovery is seriously stifled. We can also conclude that an EU-VAT is the preferred type of tax. Taxing consumers without changing relative prices is the least intrusive way to collect taxes in the market’s competitive-entrepreneurial discovery process.

An FTT is not relevant in its present form as a new own resource as it is a tax on business to business. It would become an option in a reformed form, i.e. if it indeed would tax consumers. However, in that case public support for it would probably dwindle. In 2011, 65 percent of European citizens were in favor of its present form, which involves taxing financial institutions (European Commission, 2011c), obviously under the incorrect assumption that consumers would not pay for it (Worstell, 2011).

However, as Milton Friedman said, “[...] the ideal tax system [...] ought to be a flat rate tax on consumption [...] it has a great virtue which is also the reason it will never exist, [it] limits what Congress can do to mess things up from year to year” (Friedman, 2005). Also, what is the likelihood of an EU VAT to be implemented given the EU decision-making process?

THE (IM)POSSIBILITY OF A CONSUMPTION TAX

What arguments favor the introduction of a consumption tax? First of all, each consumer will be able to see on every sales slip which part of the VAT is going to Brussels. What also stands out is its visibility and simplicity. It could create a better bond between citizens and the Union; the higher visibility of the EU could result in increased political accountability for expenditure decisions. It also brings the size of the EU budget into perspective. A 1% sales tax, as the Commission is thinking of, could furnish about one third of the EU budget. Second, it is easy to introduce. If, as proposed, the total burden for the citizens indeed remains the same (European Parliament, 2007; HLGOR, 2016: 7), it can be introduced simply: all that needs to be done is deducting the EU rate of 1 percent point from the current national VAT rates. Third, the VAT is a stable source of revenue and growth in line with increased spending without any change in its rate (cp. HLGOR, 2016: 53-55).

What arguments exist against the introduction of a consumption tax? First of all, it is most likely that lip service will be paid to earlier statements that the burden for the citizens will stay the same. Citizens will identify the EU VAT as an additional, and most of all, regressive burden. Of course, overall the national contribution of every MS to the EU will stay the same; however, a larger part will be paid through a direct contribution by the citizens. After all, the overall ceiling for the total amount of own resources that may be collected is fixed. The GNI based own resource is always used as a balancing tool; it is a truly residual resource. Second, what can also be an injustice is that because of national differences regarding tax fraud and administrative efficiency the postulate of horizontal equity between EU citizens is violated. In the 1990s the rate of VAT evasion and fraud ranged, e.g., from 2.4 percent in the Netherlands to 34.5 percent in Italy (Heinemann, *et.al.*, 2008). Third, the visibility of the tax could also work against its introduction. Citizens cannot be fooled into thinking that someone else is footing the bill as is the case with, e.g., an FTT or corporate income tax. Fourth, the introduction of an EU VAT is difficult. The decision-making process for the own resource system is amongst the Union’s most difficult ones: after consultation of the European Parliament, the proposal of the European Commission must be adopted unanimously by the Council and the national parliaments of the MS.

In order to facilitate a rational discussion that will fulfill the quality demands of both national and international law, the EU must also arrive at a manageable list of criteria to assess the new tax (Heinemann, 2008). In the past, both the Commission and the European Parliament have mentioned visibility, simplicity, financial autonomy, efficiency, sufficiency, cost-effectiveness, stability of revenue, equity, and added value for Europe as potential criteria. The problem is how to tackle this “shopping list” of criteria that the VAT, or any other EU tax, would have to meet. What criteria do we include in our measurement and what weights are attached to these criteria? Over the years all has been tried and done to solve this problem (Begg & Grimwade, 1998; Cattoir, 2004; European Parliament, 1997; Federal Ministry of Finance, 2014).

The latest list of criteria and the quantitative assessment thereof (HLGOR, 2016, pp. 87-94) mentions the classical sufficiency and stability criteria, vertical and horizontal aspects of ‘fairness’ requirements and it also looks if the tax tackles EU policy objectives. However, as was the case with all previous attempts, it doesn’t solve the problem either. The EU admits that none of the proposed own resources *per se* fulfill all of the, sometimes even contradictory, requirements. According to the HLGOR (2016, p. 36), however, together they do meet the requirements. That is, if we only look at the fulfilled criteria. Obviously, this is a rather weak argument. Similarly, if we would only look at the criteria that are not fulfilled it could be concluded that together they don’t fulfill the criteria.

Moreover, is there a compelling reason at all for introducing a new EU tax? After all, the present GNI based own resource has some strong points. It is a reliable, stable tax that by definition generates sufficient income, and it receives support from the MS. National payments of the GNI resource are easy to calculate, understood by the citizens, and they are seen as a good indicator for the national capability to pay. In short, the

system is seen as a simple and fair way of financing, even though some countries do of course underestimate their GNI because of tax fraud. In sum, the GNI contribution is not much different from what the European Parliament wants to achieve with an EU VAT. The only difference is that no direct relation exists with the EU citizens, and the financial autonomy for the European Union would not be changed. Besides that, at the beginning of the 1980s the Union got its true own resources---and still there were budgetary battles.

What's in a name?

It should be noted that the EU avoids the sensitive word EU tax in its documents, albeit inconsistently. The reason for this is that the EU does not have the power, the sovereignty, to tax, which is a fact that the Treaty clearly recalls. So to reform the system of own resources by talking of EU taxes can raise suspicion of the existence of a hidden agenda to compromise the Member States' fiscal competences (HLGOR, 2016: 20).

Member States, however, seem to interpret a new own resource as an EU tax, i.e. as a loss of their fiscal sovereignty. Hence, the European Parliament (2007) emphasizes that “fiscal sovereignty will be maintained, but only temporary the receipts of certain taxes will go directly to the EU”. Or as the HLGOR puts it:

“[T]he Union's own resources can be defined as revenue allocated irrevocably to the Union to finance its budget and accruing to it automatically without the need of any subsequent decision by the national authorities. The initial decision to attribute any particular source of revenue remains a national competence” (2016, p. 20).

Since the initial decision is still made at the level of the MS, as far as the Union is concerned, the tax competences also remain with the national authorities. The attribution of own resources is decided according to the most stringent procedure of decision-making: unanimity in the Council and ratification by all of the MS in accordance with their respective constitutional requirements. After this the revenue is “owned” by the EU.

The EU is anxious to make the characteristic of a “genuine” own resource as clear as possible in the way that MS account for their contributions to the EU. Contributions of MS to other organizations, like the United Nations, are to be clearly distinguished from contributions to the Union. Contributions to, e.g., international organizations are often the instruments of national power games to the detriment of the stability and predictability of the policies of the entire organization (HLGOR, 2016: 20). Therefore one of the Commission's wishes is that national budgets should not present their share of EU own resources as transfers from their national budgets. In other words, they should not count such revenues as government income first, but as resources owned directly by the EU and raised on behalf of the Union (European Parliament, 2014). In sum, the contribution to the Union is an appropriation levied for the EU and a reduction in government income and hence not a government expenditure. However, so far only four countries have classified the EU contribution as an attribution of national receipts to the EU and thus as a reduction in income of the central government.

Hence, the EU does not speak of taxes but of own resources. It should be noted that from an economic viewpoint, the eternal socialization of an asset's return is the same as the socialization of the asset itself (Sinn & Feist, 2000). *Mutatis mutandis*, this is also true for the temporary pooling of the revenue of taxation.

Notwithstanding that which was just said, with the new EU VAT the MS will probably still continue to try to balance their net contributions and net benefits. *Juste-retour* behavior is natural and hard to fight (Leen, 2011). Moreover, for the Union the goal of achieving autonomy, previously mentioned as one of the criteria to assess a new own resource, is or ought to be no goal at all. In order to qualify as an own resource financial independence is necessary. The same is true for the traditional own resources: the common custom duties and agricultural and sugar levies are fiscal resources levied on companies and/or individuals, whose proceeds are attributed directly to the EU even if they are collected at the national level. “This ‘right of access to the source of taxation’, which involves independence from decisions of Member States—also called financial autonomy—is considered essential to qualify as an OR [Own Resource] in the literature” (HLGOR, 2016: 22).

Financial autonomy is obviously something that every bureaucracy wants, though. This is illustrated, in the extreme, by the Commission's reluctance some years ago to have its finances checked by its own chief

accountant (Andreasen, 2009). Therefore, autonomy can never be a goal per se. It can only be a goal because of some other goal that otherwise cannot be attained. For the Union this clearly is the goal of securing expenses with an added value for Europe as a whole. For the same reason, however, an EU tax may lead to less budgetary discipline at the European level. As Wolfgang Schäuble, the German Minister of Finance, said to Monti: “Any reform of the EU’s financing system must therefore pay adequate attention to taxpayers’ interests. In the existing system, it is mainly the net contributions that look after these interests” (Federal Ministry of Finance, 2014: 1).

Policy conclusion (2): a mission impossible or a package deal

Affirming the pros, why do they seem to be outweighed by the cons? Notwithstanding the intentions of the Commission and Parliament, the total VAT rate will probably increase, and regressivity and social justice will be at the forefront of the discussion. The problem of tax fraud, and hence horizontal equity, will not be easy to overcome. This is true in spite of the Union’s policy to achieve a better overall VAT by tax harmonization. That policy will probably mostly reduce cross-border VAT fraud. The EU decision-making process, however, looks to be the most insurmountable obstacle. Since contributions change, *juste-retour* behavior will be pervasive.

In sum, from an Austrian perspective a consumption tax, next to seigniorage, is the preferred tax. The chances that such a tax will be introduced are slim, though. However, as indicated, the budget is often just the snake oil to make the really important decisions possible. “So, instead of spending it efficiently, it is best to use it, and if need be waste it, in such a way that Member States can reach much more important political deals” (Figueira, 2008, p. 2). Political horse-trading is also likely to occur. This is not much different from the solution that an expert group installed by the Commission is hinting at in its conclusion regarding the introduction of new EU taxes---reaching an agreement by creating a package deal (Ferrer, *et.al.*, 2016, p. 136).

REFERENCES

- Andreasen, M. (2009). *Brussels Laid Bare*, Yelverton.
- Arthur, W.B. (2013). Complexity Economics: A Different Framework for Economic Thought. SFI Working Paper, 104, 012.
- Begg, I. & Grimwade, N. (1998). *Paying for Europe*, Sheffield.
- Cattoir, P. (2004). Tax-based EU own resources: An assessment. Working paper No. 1, European Commission.
- European Commission (2004). Commission report on the operation of the own resource system.
- European Commission (2011a). Commission Staff Working Paper, Financing the EU budget: Report on the operation of the own resources system, SEC (2011) 876 final, Brussels.
- European Commission (2011b). A Budget for Europe 2020.
- European Commission (2011c). Financial Transaction Tax: Making the financial sector pay its fair share. IP/11/1085.
- European Commission (2016). A new start for Europe, http://ec.europa.eu/budget/mff/index_en_fm.
- European Parliament (1997). Die Eigenmittel der Europäischen Union: Analysen und Entwicklungsmöglichkeiten, Luxembourg.
- European Parliament (2007). On the future of the European Union’s own resources (2006/2205 (INI)).

European Parliament (2014). 'How do Member States handle contributions to the EU budget in their national budgets?', Study by the Budgetary Affairs Department.

Federal Ministry of Finance (2014). Workshop on the Future of EU Finances in Berlin, 10 July 2014.

Ferrer, J.N., Le Cacheux, J. & Benedetto, G. (2016). Study on the potential and limitations of reforming the financing of the EU budget.

Figueira, F. (2008). A Better Budget for Europe: Economically Efficient, Politically Realistic. *European Policy Analysis*, April, 2.

Friedman, M. (2005). Testimony before The President's Advisory Panel on Federal Tax Reform.

Hayek, F.A. (1945). The Use of Knowledge in Society. *American Economic Review*, XXXV, 4, 519-30.

Hayek, F.A. (1949). *Individualism and Economic Order*, London.

Hayek, F. A. (1982). *Law, Legislation and Liberty*, London.

Hayek, F.A. (1988). *The Fatal Conceit. The Errors of Socialism*. London and New York.

Heinemann, F., Mohl, P. & Osterloh, S. (2008). *Reform Options for the EU Own Resources System*, Heidelberg.

HLGOR (2016). Future Financing of the EU. Final report and recommendations of the HLGOR, December.

Kirzner, I.M. (1962). Rational Action and Economic Theory. *Journal of Political Economy*, LXX, 380-85.

Kirzner, I.M. (1973). *Competition and Entrepreneurship*. Chicago.

Kirzner, I.M. (1985). *Discovery and the Capitalist Process*. Chicago.

Kirzner, I.M. (1988). The Economic Calculation Debate: Lessons for Austrians. *The Review of Austrian Economics*, 2: 1-18.

Kirzner, I.M. (1999). Self-Interest & the new Bashing of Economics. *Critical Review*, 4, 1&2, 27-40.

Leen, A.R. (2011). What an EU Tax Means. *EC Tax review* 20, 4, 203-5.

MacDougall Report (1977) Brussels, April.

Sinn H-W. & Feist, H. (2000). Seigniorage wealth in the eurosystem: eurowinners and eurolosers revised, CESifo Working Paper Series, 353.

Worstell, T. (2011). Who Pays Financial-Transaction Taxes? Just about everyone, except banks. *Wall Street Journal*, June 22.

MANAGING ORGANISED SPORT: ARE ALTERATIONS TO SCHOOL SPORT VALUES NECESSARY?

Anita Lennox
North West University, South Africa

ABSTRACT

Organised sport influences children both positively and negatively and in this regard the school and the parents play an important role on how children experience sport. The aim of this study was to assess different experiences of mini-rugby players and the perceptions of their parents regarding their participation and the differences between schools within the Vaal Triangle area in the Gauteng province. For the study, 180 boys and 96 parents completed an adapted version of the Sport Competition Anxiety Test (SCAT) and the Competitive State Anxiety Inventory (CSAI-2) (Martens, Vealey & Burton, 1990), measuring cognitive and somatic anxiety, self-confidence and sport-related negative aspects, such as spectator behaviour influence, withdrawal and the winning motive. An independent t-test indicated significant differences between players and parents of the different schools ($p < 0.005$). These differences were analysed further to determine the differences between the schools. Results of this study are indicative of the influence of school values and behaviours by parents and coaches towards sport and the negative influence on childrens' participation experiences. This information can help with future management of organised sport in schools.

Keywords: Organised mini-rugby, school, sport participation, parents.

INTRODUCTION

The influence of organised sport on children has been studied for a few years and there are positive and negative factors that were identified with these studies (Annesi et al., 2007; Raubenheimer & Le Roux, 2008; Eime, Young, Harvey, Charity, & Payne, 2013; Merkel, 2013). On the positive side, participation in sport improve health, psychological, social and emotional well-being more specifically noting higher self-esteem, better social skills, higher confidence as well as higher competence in children (Eime et al., 2013; Merkel, 2013; Na, 2015). Team sport seems to be linked more with improved health effects compared to individual sport due to the social nature of participation (Eime et al., 2013). Participation in organised sport also contribute in breaking the awful cycle of our time with regard to more technology and screen time, which in turn increase inactivity and unhealthy lifestyles in our children (Merkel, 2013). From a health perspective, organised sport also have positive effects on decreasing the risk of heart disease, diabetes and obesity (Kristensen et al., 2013; Merkel, 2013). However, organised sport may also have negative effects on children such as anxiety, stress and eventually their withdrawal from sport (Raubenheimer & Le Roux, 2008; Merkel, 2013). Crane and Temple (2015) found that lack of enjoyment, perceptions of competence, social pressure, competing priorities and physical factors are major reasons why children withdraw from sport. Various factors also have an influence on how the children experience sport participation including parents, coaches, grade level as well as school sport programme (Bailey, 2006).

The manner in which children experience organised sport are influenced by parents, coaches and peers (Bailey, 2006; Walters, Schluter, Oldham, Thomson, & Payne, 2012; Na, 2015) and their involvement and interaction either have a positive or negative effect. The study focused on the role of parents in organised sport and how children experience their involvement. Parent involvement can be seen as a multidimensional construct

consisting of specific thoughts and emotions related to a child's activities and are noticeable as parent support and pressure behaviour (Hoyle & Leff, 1997; Harwood & Knight, 2016). As children start to participate in sport parents adopt the role of motivator, facilitator and coach and offer financial, emotional and physical support to their children (Hoyle & Leff, 1997; Knight, Dorsch, Osai, Haderlie, & Sellars, 2016). Through parents' involvement, they can either help create enjoyment by providing support and encouragement or be a source of stress and anxiety by placing excessive pressure on a child (Hoyle & Leff, 1997; Stein, Raedeke, & Glenn, 1999). Dorsch, Smith, and McDonough (2015) determined in their research that sport participation provide different opportunities for family communication and bonding. In this regard, Stein et al. (1999) found that parents need to consider the quality of involvement in terms of involvement degree and not the involvement level. Parental involvement lies on a continuum ranging from low to high involvement. High involvement is associated with over involvement and low involvement, a lack of support or under involvement (Stein et al., 1999). Parents who increase their degree of involvement in their child's sport may be viewed by their children as stress factor, rather than being supportive (Kanters, Bocarro, & Casper, 2008). Parents who also places too high expectations or too much emphasis on winning, decrease their children's confidence and they often seek to participate in other sports for fun (Merkel, 2013). Various studies have shown that the primary reason for children to withdraw from sport was because of the lack of enjoyment (Kanters et al., 2008; Raubenheimer & Le Roux, 2008; Crane & Temple, 2015). Literature indicates that the manner in which children experience their participation are strongly influenced by parents.

Mini-rugby school sport

The International Rugby Board (IRB) started mini-rugby to increase the participation in the sport by changing the rules and playing field to enable skill development and enjoyment (Rutherford, 1993). Nonetheless, schools in South Africa, within regions can agree to a variant from the non-competitive, developmental focus of mini-rugby to a format and rules that echo the values regarding youth sport participation. This research ascend from media reports of inappropriate school sport values, attitudes and behaviours of coaches and parents (Cilliers, 2013). Recent studies pertaining this data in this regard have been published and the aim of this study was to assess different experiences of mini-rugby players and the perceptions of their parents regarding their participation and the differences between schools.

METHOD AND PROCEDURE

A non-probability sampling design in the form of convenience sampling was used to collect data. This method was inexpensive and efficient. This method had limitation and to surmount it, a great sample group was targeted.

Participants

Five mainstream schools in the Gauteng province that presented mini-rugby as an organised sport were requested to participate, where after the schools accepted on precondition to remain anonymous. Schools were named "School A", "School B" etc. and will be referred to in this manner. Mini-rugby boys in grade one and two were recruited to complete a questionnaire voluntarily and anonymously after a parent conceded written permission to participate in the study. In a controlled setting, the researcher, supported by research co-worker as well as the boy's teachers administered the questionnaire.

Measuring instrument

The questionnaire comprised two sections, Section A included demographic information and Section B contained 37 items consisting out of the six subscales, namely enjoyment, pressure, anxiety, spectator behaviour, withdrawal and the winning motive. The questionnaire was altered from Raubenheimer and Le Roux (2008),

using the Sport Competition Anxiety Test (SCAT) and the Competitive State Anxiety Inventory (SCAI-2) developed by Martens, Vealey, and Burton (1990). Scales measuring self-confidence (Martin & Hall, 1997) and negative aspects of sport participation such as withdrawal (Cahill & Pearl, 1993) were also incorporated. Items were recorded using a four-point Lickert scale (one being usually and four being always). The questionnaire rendered a Cronbach alpha of 0.88 in (Raubenheimer & Le Roux, 2008) study.

Data collection

An alteration of the questions was required to be more appropriate for the age-specific language and vocabulary of the six to eight year olds in this study. Furthermore, expert researchers and school teachers pre-tested the instrument and found the content to be simple, readable, age applicable and administrable. Individual attention was given to administer the surveys and researchers and teachers clarified the questions using basic language and by referring to examples, thus ensuring participants understood the questions before they chose their answers.

RESULTS

Data were captured and analysed using the Statistical Package for Social Sciences (SPSS-Version 23). Descriptive statistics indicated that 52.1 percent of the boys were in grade one with 47.9 percent in grade two. Table 1 illustrates the distribution of participants between schools.

Table 1: Distribution of participants between different schools

	Boys	Parents	Total
Sample size (N)	180	96	276
School A	36	22	58
School B	35	22	57
School C	50	16	66
School D	19	18	37
School E	40	18	58
% of group	65.2%	43.8%	100%

In Figure 1-5 the different perceptions between the parents and the boys in each school are displayed and deliberated.

Figure 1: Difference between boys and parents of School A

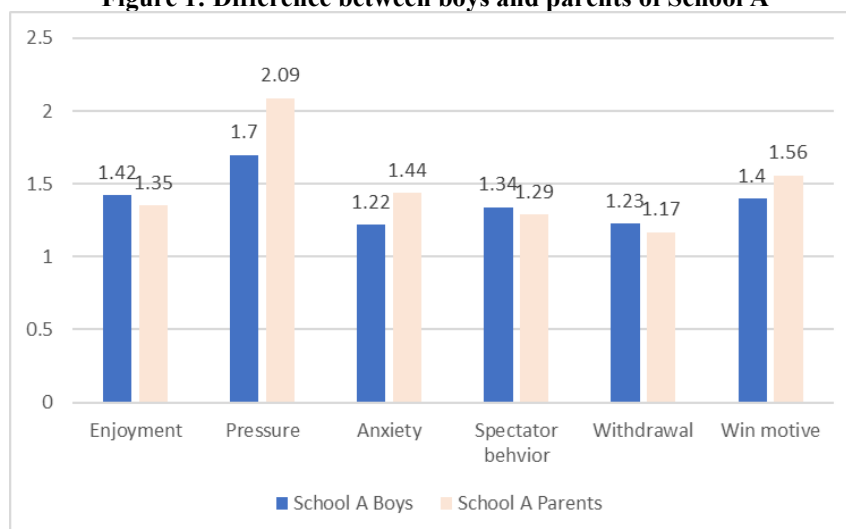

There are no statistical difference between the boys and parents of School A. The parents of School A showed a perception that the boys experienced more pressure than the experience of the boys themselves. The parents of School A had a good perception of their boys experience of mini-rugby.

Figure 2: Difference between boys and parents of School B

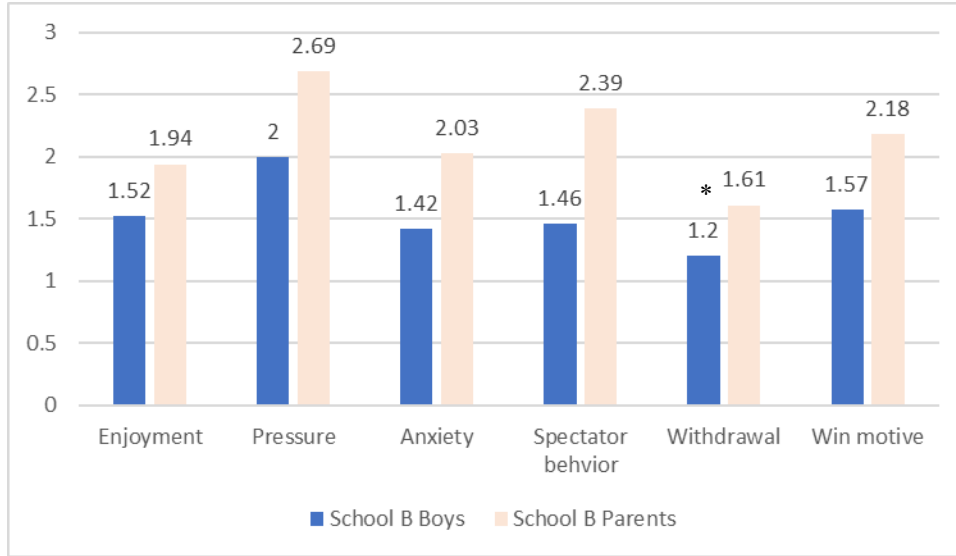

The perception of parents of School B were in all five constructs higher compared to the experience of the boys regarding the related aspects (Figure 2). A significant difference was found between the parents' perception and boys' experience with regard to withdrawal ($p=0.003$). The parents also perceived that the spectator behaviour will influence the boys more than the boys experienced. The winning motive was also much higher in the parents and can be ascribed that the focus from the parents is stonger in this regard.

Figure 3: Difference between boys and parents of School C

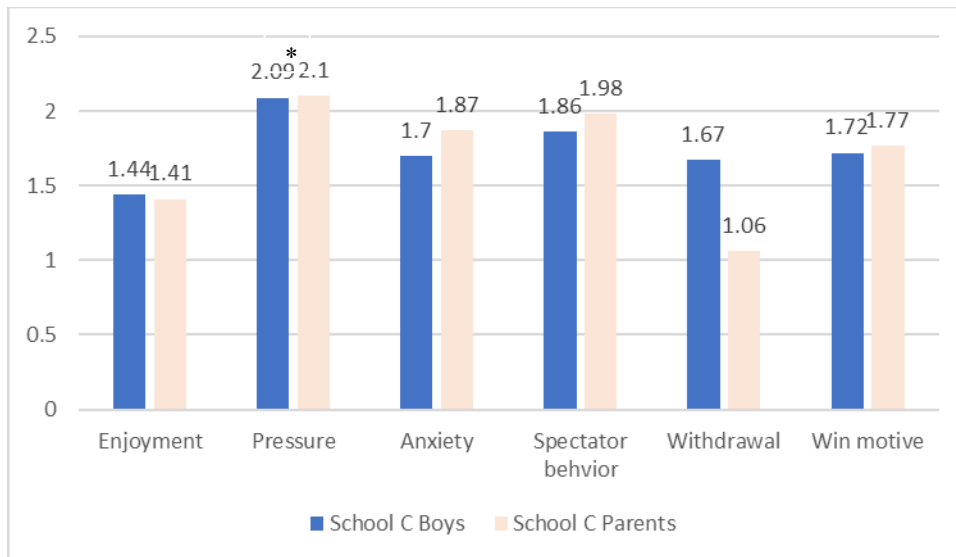

Boys in School C (Figure 3) had a higher experience regarding withdrawal compared to the perceptions the parents have of their boys inclination towards withdrawing from rugby. Significant differences were found with regard to pressure ($p=0.002$), the values indicate that the experience of the boys are almost the same as the perceptions of the parents. The perception of the parents are higher than the boys' experienced with regard to anxiety and spectator behaviour.

Figure 4: Difference between boys and parents in School D

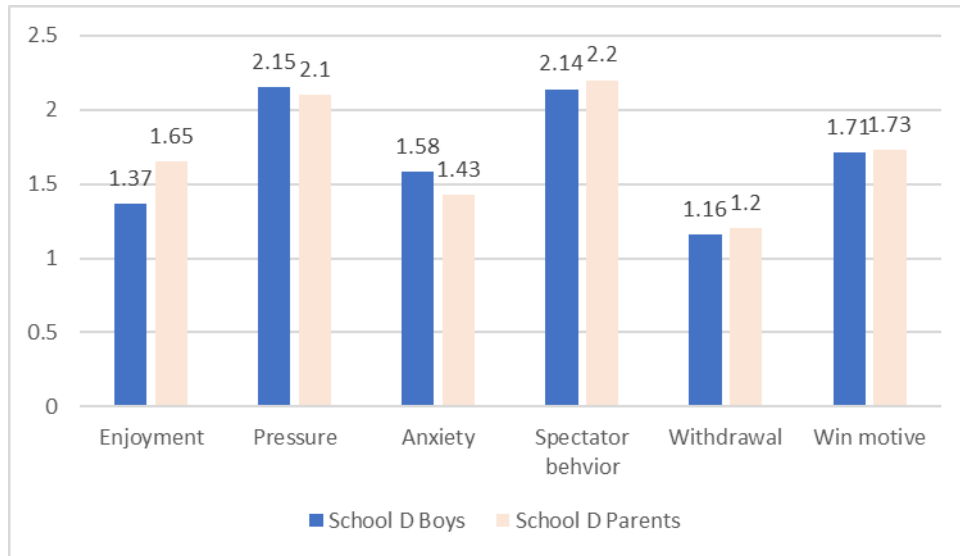

Parents of School D perceived that the boys enjoy the rugby more than the boys experienced as shown in the higher value of the parents (Figure 4). The boys experience of anxiety were also higher than the perception of the parents. Perceptions regarding the winning motive is equally high in both groups. No statistical significant differences were found between the groups.

Figure 5: Difference between boys and parents in School E

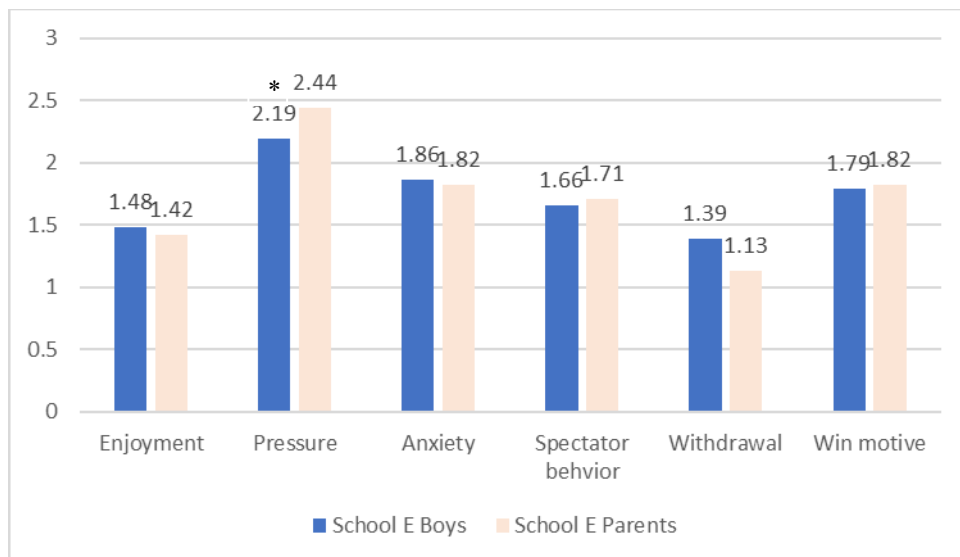

In School E (Figure 5) the boys had a higher experience regarding withdrawal than the perceptions of the parents. A significant difference was also found with regard to pressure ($p=0.005$), the boys experienced less pressure than perceived by the parents. The win motive are almost equal in both the groups as well as spectator behaviour.

DISCUSSION

Results indicated that there were different combinations of perceptions regarding the enjoyment, pressure, anxiety, spectator behaviour, withdrawal and winning motives in each of the schools. In School A, it seems as if the parents have a better perception regarding their boy's experience in mini-rugby and the overall sport focus could be more on participation rather than winning. This is equally evident in the experience of lowest levels of pressure and anxiety for boys from School A compared to the other schools. Parents in Schools A and B had a higher perception regarding the winning motive compared to the parents in Schools C, D and E, where the perception were almost equal between the groups. Boys in School E showed the highest value for the win-motive compared to boys in the other schools, which could indicate that there is a stronger emphasis with regard to this aspect in that particular school. This study focused on the experience of boys and the perception of their parents, however, the school culture and coaches also play an important role in the boy's experiences (Bailey, 2006; Walters et al., 2012; Merkel, 2013). It can be concluded from the results, that school culture and values at each school pertained different focuses with regard to boys' participation in mini-rugby. Results of this study are indicative of the negative influence of school values and behaviours by coaches in the experiences of anxiety, pressure and withdrawal of boys. This is important for the management of mini-rugby from the schools to create a culture and focus of mass participation and enjoyment in the sport. At mini-rugby level, schools should shift their focus from competition to more skill development, fun-orientated and to foster the enjoyment of physical activity and sport in participating boys.

The perceptions displayed by the parents indicate that the boys experienced more pressure and anxiety, but also less enjoyment during their participation. These results are important for the managers of school sport and mini-rugby for the parents to focus more on enjoyment, skills development as well as parental support and less on competitive situations. The lack of enjoyment is one of the major aspects that will cause withdrawal from the sport (Crane & Temple, 2015). These days' children spend more time with technology and inactivity is becoming a global problem, participation in mini-rugby can help with the activity levels of boys and also improve the bonding between children and parents. In this regard Na (2015) found that the perceptions of parents with regard to youth sport programmes indicated an important learning context for promoting physical, social and emotional development, it can also improve bonding between family members. Parents' focus should also shift to more encouragement of sport participation such as mini-rugby as well as to promote a physically active lifestyle to improve children's health.

Results of this study are indicative of the influence of school values and behaviours of parents and coaches towards sport and the negative influence on participation experiences. These findings can be utilised to improve the focus and management of mini-rugby with regards to the focus from the school to be more fun-orientated and focused on skill development. As from the perspective of the parents, their involvement is very important and could aid in the focus of enjoyment as well as the type of support they provide for their child. This study indicated that children do experience anxiety and pressure, future research can investigate the specific factors that parents recognise that could enhance the pressure on the children experience.

REFERENCES

- Annesi, J. J., Faigenbaum, A. D., Westcott, W. L., Smith, A. E., Unruh, J. L., & Hamilton, F. G. (2007). Effects of the Youth Fit For Life protocol on physiological, mood, self-appraisal, and voluntary physical activity changes in African American preadolescents: Contrasting after-school care and physical education formats. *Int J Clin Health Psychol*, 7(3), 641-659.
- Bailey, R. (2006). Physical education and sport in schools: A review of benefits and outcomes. *Journal of school health*, 76(8), 397-401.
- Cahill, B. R., & Pearl, A. J. (1993). *Intensive participation in children's sports*: Human Kinetics Publishers.
- Cilliers, S. (2013). Verbied rugby vir bulletjies. *Beeld*. Retrieved from www.netwerk24.com/Nuus/Verbied-rugby-vir-bulletjies-20130417.
- Crane, J., & Temple, V. (2015). A systematic review of dropout from organized sport among children and youth. *European physical education review*, 21(1), 114-131.
- Dorsch, T. E., Smith, A. L., & McDonough, M. H. (2015). Early socialization of parents through organized youth sport. *Sport, Exercise, and Performance Psychology*, 4(1), 3-18.
- Eime, R. M., Young, J. A., Harvey, J. T., Charity, M. J., & Payne, W. R. (2013). A systematic review of the psychological and social benefits of participation in sport for children and adolescents: informing development of a conceptual model of health through sport. *International Journal of Behavioral Nutrition and Physical Activity*, 10(1), 98.
- Harwood, C. G., & Knight, C. J. (2016). Parenting in Sport. *Sport, Exercise, and Performance Psychology*, 5(2), 84-88.
- Hoyle, R. H., & Leff, S. S. (1997). The role of parental involvement in youth sport participation and performance. *Adolescence*, 32(125), 233-244.
- Kanters, M. A., Bocarro, J., & Casper, J. (2008). Supported or Pressured? An Examination of Agreement Among Parent's and Children on Parent's Role in Youth Sports. *Journal of Sport Behavior*, 31(1), 64-80.
- Knight, C. J., Dorsch, T. E., Osai, K. V., Haderlie, K. L., & Sellars, P. A. (2016). Influences on Parental Involvement in Youth Sport. *Sport, Exercise, and Performance Psychology*, 5(2), 161-178.
- Kristensen, P. L., Olesen, L. G., Ried-Larsen, M., Grøntved, A., Wedderkopp, N., Froberg, K., & Andersen, L. B. (2013). Between-school variation in physical activity, aerobic fitness, and organized sports participation: a multi-level analysis. *Journal of sports sciences*, 31(2), 188-195.
- Martens, R., Vealey, R. S., & Burton, D. (1990). *Competitive anxiety in sport*: Human kinetics.
- Martin, K. A., & Hall, C. R. (1997). Situational and intrapersonal moderators of sport competition state anxiety. *Journal of Sport Behavior*, 20(4), 435.
- Merkel, D. L. (2013). Youth sport: Positive and negative impact on young athletes. *Open Access J Sports Med*, 4, 151-160.
- Na, J. (2015). Parents' perceptions of their children's experiences in physical education and youth sport. *Physical Educator*, 72(1), 139.
- Raubenheimer, G., & Le Roux, K. (2008). Die jong kind se belewenis van intensiewe sportdeelname. *South African Journal for Research in Sport, Physical Education and Recreation*, 30(1), 75-88.

Rutherford, D. (1993). *The Complete Book of Mini Rugby*: Partridge Press.

Stein, G. L., Raedeke, T. D., & Glenn, S. D. (1999). Children's perceptions of parent involvement: it's not how much, but to what degree that's important. *Journal of Sport Behavior*, 22(4), 591.

Walters, S. R., Schluter, P. J., Oldham, A. R., Thomson, R. W., & Payne, D. (2012). The sideline behaviour of coaches at children's team sports games. *Psychology of sport and exercise*, 13(2), 208-215.

PREPARING STUDENTS FOR THE WORKPLACE – DEVELOPMENT OF SOFT SKILLS

Anita Lennox and Fanie Roos
North-West University, South Africa

ABSTRACT

Students need certain soft skills to enter the workplace and tertiary institutions have to ensure that students acquire these skills before they enter the workplace. Outdoor education programmes are used to develop these skills and this study investigated the use of an outdoor Amazing Race programme to develop certain soft skills including problem-solving, leadership, teamwork and communication. Data collection were performed by means of a self-administered questionnaire consisting of qualitative questions. These questionnaires was completed by 200 students who participated in an on campus Amazing Race. The data were analysed using qualitative techniques proposed by Côte, Salmela, and Russel (1993) and subsequently numerically coded to include frequency counts. The results indicated that students identified communication, leadership, teamwork and problem-solving as skills that were developed. This confirms that an outdoor education programme can be used to develop much needed soft skills students need to enter the workplace.

Keywords: Soft skills, students, outdoor education programmes, Amazing Race.

INTRODUCTION

A global gap exists between education and employability of students regarding soft skills acquisition (Schulz, 2008; Horwitz, 2013; Feffer, 2016; Taylor, 2016; Ghosh, 2017). Technical skills and knowledge alone are insufficient for employability and success in today's modern workplace (Schulz, 2008; Taylor, 2016; Wesley et al., 2017). This evolvement in the workplace cannot be ignored (Khanam & Khanam, 2017). Therefore tertiary institutions need to shift their focus from knowledge transfer to include the development of soft skills, application of knowledge as well as practices (Maharasoia & Hay, 2001; Taylor, 2016). The ability of tertiary institutions to ensure employability has become a marker of the quality of the institution, as well as a marketing tool for academic programmes.

Technical or hard skills can be defined as the skills that an individual acquired as part of their education and work experience (Robles, 2012). This therefore, refers to the knowledge or level of expertise that an individual need for a specific job (Khanam & Khanam, 2017). Current employers are looking beyond hard skills and require of candidates to possess various characteristics and skills that are not directly addressed by tertiary degrees and programmes (D'Eloia & Fulthorp, 2016). Soft skills are manageable and developed over time and include group work, problem-solving and leadership (Collins, Sibthorp, & Gookin, 2016).

Soft skills are described as good interpersonal skills including communication, problem-solving, decision-making, time management, leadership, and teamwork (Schulz, 2008; Taylor, 2016; Khanam & Khanam, 2017). Khanam and Khanam (2017) identify soft skills as the emotional intelligence that an individual possesses. Soft skills are qualities and habits of an individual that can be changed or improved to shape their personality (Schulz, 2008). These qualities and habits will ensure work success as well as good collaboration with colleagues (Schulz, 2008). According to Khanam and Khanam (2017), hard skills may ensure that an individual become employed at a company, however, soft skills may bring about various other opportunities.

It is important to define some of these soft skills mentioned in more detail. According to Oxford University Press (Anon, 2017a; Wesley *et al.*, 2017), communication can be defined as imparting or sharing information whether verbally or non-verbally. Communication is the means by which professional businesses communicate globally and is therefore of paramount importance for employees (Khanam & Khanam, 2017; Wesley *et al.*, 2017). In the workplace employees are faced with problems on a regular basis, the ability to make sense of the situation and provide a solution is crucial, therefore problem-solving in the professional environment is a valued quality employees need (Wesley *et al.*, 2017). Equally important is time management, this can be referred to as the skill to develop effective strategies in order to complete tasks. As such, time management assists employees to complete important tasks on time (Khanam & Khanam, 2017). Leadership is the next important quality needed in employees. Employees that take initiative, motivate others and have a positive attitude, will have a positive effect on the functionality of an organisation. This is a skill that will benefit businesses of all dimensions (Khanam & Khanam, 2017). The last skill important in employability, is teamwork. When implemented effectively teamwork will minimise conflict and increase creativity, this in return will have a better success rate for the individual and business as result (Wesley *et al.*, 2017). When these skills are absent, long-term job success may not be guaranteed and unemployment may be the end result (Feffer, 2016).

South Africa has a high unemployment rate of 26.5% as well as skill shortages (Horwitz, 2013; Anon, 2017b). This needs to be addressed by tertiary institutions delivering students that can meet the demands of the industry. Tertiary institutions need to change their way of teaching to incorporate more soft skills together with the technical or subject knowledge (Schulz, 2008). In a way, some lecturers combine soft skills with activities students do in class, such as group assignments, presentations and group work, as well as outdoor adventure programmes (Hattie, Marsh, Neill, & Richards, 1997). A curriculum needs to entail soft skill subjects that will complement the technical skills that are taught. As a result of curriculums lacking soft skill programmes, students are forced to seek various other ways to develop their soft skills (Schulz, 2008).

Outdoor education programmes are used to develop these soft skills (Cooley, Burns, & Cumming, 2015), not only at tertiary institutions but also other educational settings. Outdoor education refers to structured outdoor activities that are completed in small groups and are mentally and physically challenging and require sufficient problem-solving and decision-making skills (Hattie *et al.*, 1997; Cooley *et al.*, 2015). Physical activity is part of an outdoor education programme, physical fitness and physical skills are not the main aim, however, it can be used for participants to identify their own strengths and weaknesses and to develop new skills (Hattie *et al.*, 1997). Most of these programmes have a competing element and its main focus is collaboration between group members (Hattie *et al.*, 1997; Cooley *et al.*, 2015).

METHOD AND PROCEDURE

The research study followed a non-probability purposeful sampling method to collect data, since the researchers intend to gain insight into the experience of a specific group of students.

Participants

Ninety-nine (2014) and one hundred and one (2015) students completed the questionnaire after participating in an on campus Amazing Race that was developed to assist them in developing certain soft skills as well as to assist them in exam preparation. Students who participated were full-time students registered for Sport Science or Sport and Recreation at a university in South Africa, aged between 18 and 24. Students were requested to voluntarily and anonymously complete the questionnaire.

Amazing Race set-up

Students divided themselves into groups of no more than 5 members per group according to the year of study and course enrolled. After the teams registered and the rules of the event were explained, all the teams started the race

from the same starting point on campus with their first clue. Each team had to complete ten stations (2014) and twelve stations (2015) that were spread across the campus in order to complete the race. Each station would be complete if the group answered a specific curriculum-related question and complete a physical activity. These questions were asked in the format of multiple choice or true or false and had to be answered correctly before the group would be allowed to do the physical activity and receive a clue to the next station. Each physical activity included cognitive activities and games with a specific outcome. The outcomes of these activities were teamwork, communication, leadership, cognitive development and social skills.

In 2014 questions and clues were given in a paper format while in 2015 technology were incorporated where a tablet was available at each station and students had to complete the questions and receive the next clue on the device. In 2014 the teams had to complete 5 physical activities and 5 module-related questions. Physical activities included slingshot shooting, dribbling a soccer ball, hitting cricket wickets and an inflatable obstacle course. In 2015 teams had to complete twelve stations. The physical activities included golf activities, boat building, relay, target shooting and building tents. Teams had to walk or run to their next station across campus, if they arrived at the wrong station, students had to rethink their previous clue. Teams arriving first at a station would receive the question and physical task first, attaining an advantage over the other teams.

Measuring instrument and Data collection

Data were collected by means of a self-administered qualitative questionnaire. Students were asked to report on the skills that they used and developed during the Amazing Race (“What skills did you develop today?”). The questionnaires were distributed immediately after completion of the Amazing Race and students had ample time to reflect and complete the questionnaire.

RESULTS

Data were analysed and grouped by means of ATLAS ti as noted by Roos, Van den Berg, Lennox, and Els (2016). The skills included communication, leadership, cognitive skills, teamwork, management and social skills. The same groups of skills were identified in 2015. Each one of these skills were given a numerical code in order to allow for further statistical analysis. Statistical analysis was performed using SPSS (version 24). Frequency counts were done to determine the amount of students that reported the specific skill.

Table 1: Skills developed and used as reported by students in past two years

Skills	2014 (n=99)		2015 (n=101)		Total (n=200)	
	Students (n)	% of students	Students (n)	% of students	Students (n)	% of students
Communication	24	24%	37	37%	61	31%
Leadership	6	6%	33	33%	39	20%
Cognitive	15	15%	25	25%	40	20%
Teamwork	24	24%	70	69%	94	47%
Management	9	9%	11	11%	20	10%
Social	20	20%	38	38%	58	29%

Students reported in both 2014 and 2015 skills that can be grouped under the main skills as illustrated in Table 1. In 2015, 69% of students reported the term teamwork in comparison to 24% in 2014. More students also reported leadership in 2015 (33%) compared to the 6% in 2014. The skill with the highest percentage noted in the total group is teamwork (47%) in contrast to the lowest that was management (10%).

The skills mentioned in Table 1 were noted by the following terms by the students:

Communication skills included the following “listening”, “communicating effectively”, “proper language usage”, “good communication skills” as well as “mostly communication that was needed to work well as a team” that indicates the importance of communication in this type of event.

Cognitive skills included “thinking critically”, “working out clues”, and “using my mind to work out clues”, “quick thinking”, “problem-solving”, “creative” and “to think and act under pressure and teamwork” were also mentioned by students.

Management skills were noted by the following terms, “management”, “time management”, “goal driven” and “decision-making skills”.

Teamwork were noted by “working in a group”, “team spirit”, “co-operation” and “team building skills”.

Social skills were noted by “patient”, “patience with people who don’t want to work together”, “confronting my fears”, “learning to motivate other students”, “respect others”, “punctuality”, “honesty” and “flexibility” to list a few.

Figure 1: Distribution of noted skills

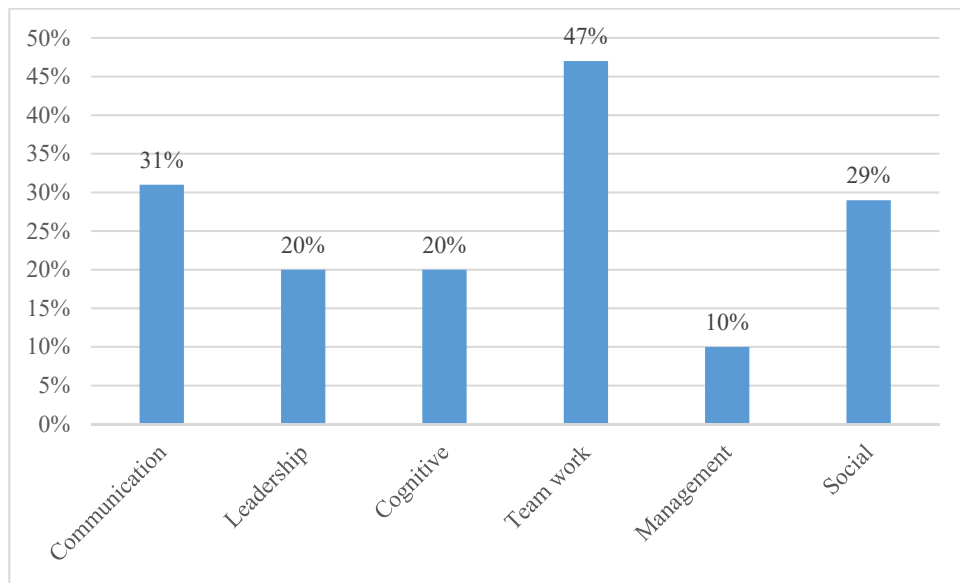

According to Figure 1, the skill that was noted by the most students was teamwork. Communication was the second most noted skill, followed by social skills.

DISCUSSION

When skills identified by students were compared to the employability skills identified by (Khanam & Khanam, 2017), the students identified teamwork and leadership skills. Decision-making, problem-solving and time management were separate skills according to Khanam and Khanam (2017). However, in this study it was grouped

together under cognitive skills (problem-solving skills, decision-making), and time management under management skills. Through this research the Amazing Race developed the necessary soft skills needed for employability and can be utilised by tertiary institutions to develop and improve these skills. According to Feffer (2016); Khanam and Khanam (2017); Wesley *et al.* (2017), soft skills such as leadership, teamwork and time management is crucial in the modern workplace and cannot be ignored.

Figure 2: Skills that Khanam and Khanam (2017) found was most important in employability

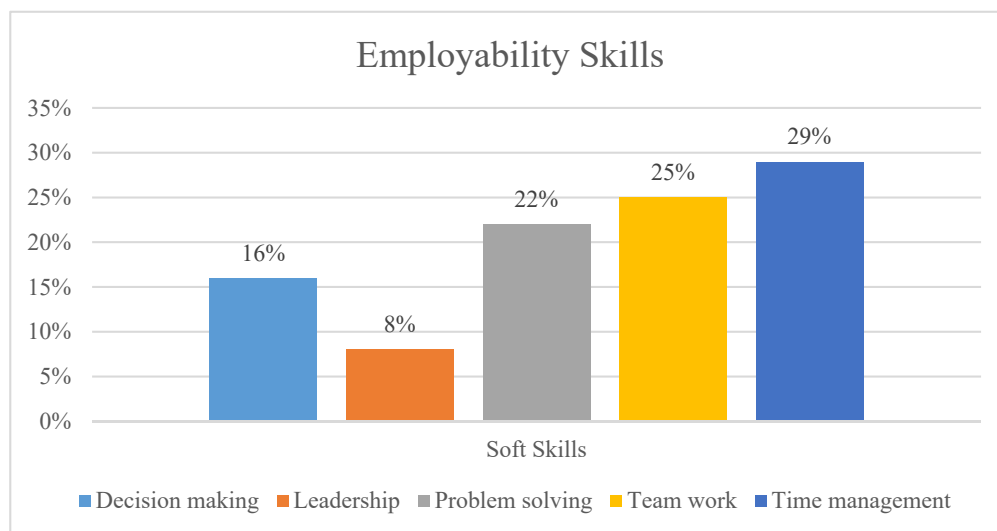

Various studies have indicated the aim of using outdoor education similar to the Amazing Race to develop certain soft skills, which include leadership, communication, group work and problem-solving skills (Hattie *et al.*, 1997; Cooley *et al.*, 2015; Robbins, 2015; Collins *et al.*, 2016). In a meta-analysis study conducted by Hattie *et al.* (1997) on 96 studies, the researchers identified six dimensions that include academics, leadership, self-concept, personality, interpersonal skills and adventure-some. In correlation with Hattie *et al.* (1997) the students in the current study identified some of the same skills, including patience, motivation, respect for others, which were categorised under social skills in the current study and Hattie *et al.* (1997) classified it under interpersonal skills.

According to Hirsch (2017) the most important skills are communication and teamwork, both of these skills were noted by the students in both 2014 and 2015. In the study of Robles (2012), the researchers identified the top 10 soft skills by business executives including integrity, communication, courtesy, responsibility, social skills, positive attitude, professionalism, flexibility, teamwork and work ethics. Schulz (2008) identifies communication, critical and structured thinking, as well as creativity, all of which were also identified in the current study.

It can be concluded that although the students did not realise that the development of soft skills were part of the activity, they noted these skills when they completed the questionnaire after the race and without being prompted with regard to the type of skills. The students in the current study noted that most of these soft skills are required for employment. With these results it can be confirmed that an outdoor education programme like the Amazing Race can be used by educators to teach students the necessary soft skills to be more employable for the industry. Through acquiring these essential soft skills in an outdoor education programme, tertiary institutions can effectively utilise outdoor education for students to become more employable for the industry.

REFERENCES

- Anon. (2017a). Definition of communication in english. Retrieved from <https://en.oxforddictionaries.com/definition/communication>.
- Anon. (2017b). Trading Economics: South Africa unemployment rates. Retrieved from <http://www.tradingeconomics.com/south-africa/unemployment-rate>
- Collins, R. H., Sibthorp, J., & Gookin, J. (2016). Developing Ill-Structured Problem-Solving Skills through Wilderness Education. *Journal of Experiential Education*, 39(2), 179-195.
- Cooley, S. J., Burns, V. E., & Cumming, J. (2015). The role of outdoor adventure education in facilitating groupwork in higher education. *Higher Education*, 69(4), 567-582.
- D'Eloia, M. H., & Fulthorp, K. (2016). Preparing for the Profession. *Schole: A Journal of Leisure Studies & Recreation Education*, 31(1), 15-28.
- Feffer, M. (2016). Going soft on talent. *HR Magazine*, 61, 60.
- Ghosh, D. (2017). Employability Enhancement and the Role of Soft Skills Training *Business Infrastructure for Sustainability in Developing Economies* (pp. 264-271): IGI Global.
- Hattie, J., Marsh, H. W., Neill, J. T., & Richards, G. E. (1997). Adventure education and Outward Bound: Out-of-class experiences that make a lasting difference. *Review of educational research*, 67(1), 43-87.
- Hirsch, B. J. (2017). Wanted. *Phi Delta Kappan*, 98(5), 12-17.
- Horwitz, F. M. (2013). An analysis of skills development in a transitional economy: the case of the South African labour market. *International Journal of Human Resource Management*, 24(12), 2435-2451.
- Khanam, L. T., & Khanam, L. Z. T. (2017). The Role of Soft Skills in Technical Education. *Global Journal For Research Analysis*, 5(9).
- Maharasoia, M., & Hay, D. (2001). Higher education and graduate employment in South Africa. *Quality in Higher Education*, 7(2), 139-147.
- Robbins, A. (2015). Synthesizing the Outdoor Education Literature to Create a Definition and List of Primary Objectives.
- Robles, M. M. (2012). Executive Perceptions of the Top 10 Soft Skills Needed in Today's Workplace. *Business Communication Quarterly*, 75(4), 453-465.
- Roos, S., Van den Berg, L., Lennox, A., & Els, B. (2016). Campus amazing race as teaching tool: Sport students' perceptions of skills developed and applied. *International Journal of Management and Applied Science*, 2(3), 6.
- Schulz, B. (2008). The importance of soft skills: Education beyond academic knowledge. *Nawa: Journal of Language & Communication*, 2(1).
- Taylor, E. (2016). Investigating the perception of stakeholders on soft skills development of students: Evidence from South Africa. *Interdisciplinary Journal of e-Skills and Lifelong Learning*, 12(1), 1-18.

Wesley, S. C., Wesley, S. C., Jackson, V. P., Jackson, V. P., Lee, M., & Lee, M. (2017). The perceived importance of core soft skills between retailing and tourism management students, faculty and businesses. *Employee Relations*, 39(1), 79-99.

CLUSTER APPROACH TO INNOVATION POLICY: RUSSIAN EXPERIENCE

Tatiana Leonova and Galina Plotnikova
National Research Nuclear University MEPhI, Moscow, Russia

ABSTRACTS

Efficiency of innovation clusters organizing is confirmed by world experience. In Russia, demand and interest of economic agencies and regional government bodies for cluster organisation and support are very high that is reflected in many cluster initiatives, which are more than 400. However, in spite of federal support, innovation clusters are not drivers of territorial development and innovation sector in the majority of Russian regions: the level of innovation activity is about % during the many years, volume of innovation products is approximately 3-4%. On our view, one of restriction for innovation sector is lack of integrated approach and unlinked strategy planning and clusters development programs.

Keywords: cluster, innovation policy, government supporting of clusters, strategic planning

INTRODUCTION

Nowadays cluster approach is actively used by Russian government bodies as federal and regional levels with goal to increase competitiveness of branches and territories and innovation companies' development.

In the frame of social and economic policy realization at the end of 2011 and beginning of 2012, President and Government of the Russian Federation made the decision about creation of the innovation and territorial clusters list and a system of supporting mechanisms of their development. Since 2012, the Program of innovation and territorial clusters supporting has been being implemented in Russia.

Those measures promoted to many cluster initiatives emergences in Russia. Now there are 107 clusters functioning in the different branches of economy, including 28 pilot innovation and territorial clusters.

Selected 28 innovation clusters are situated on the territories of high scientific, technical and production potential concentration, such as science cities, special economic zones, closed towns. Clusters incorporate 1472 organisation. The number of employees amount 713 thousand peoples, or 1% of employment.

The government assist to necessary engineering and market infrastructure creation for clusters through the mechanism of target subsidization, and by mean of the Programs of scientific and innovation activity supporting.

Despite of the all measures, one of the problem is a discrepancy between the system of strategic planning and cluster policy. So, it is very important task to ensure synchronization of clusters and territories of their location development programs on the regional level, and clusters and industries on the federal level.

THE STRUCTURE OF INNOVATION CLUSTERS

There three models of pilot innovation clusters:

- “Cornerstone” territories of big high technology business – 12 clusters;
- Territories of small and medium innovation business concentration – 7 clusters,
- Leading innovation and educational centers – 6 clusters (Fig. 1).

Fig. 1 Models of Innovation Clusters

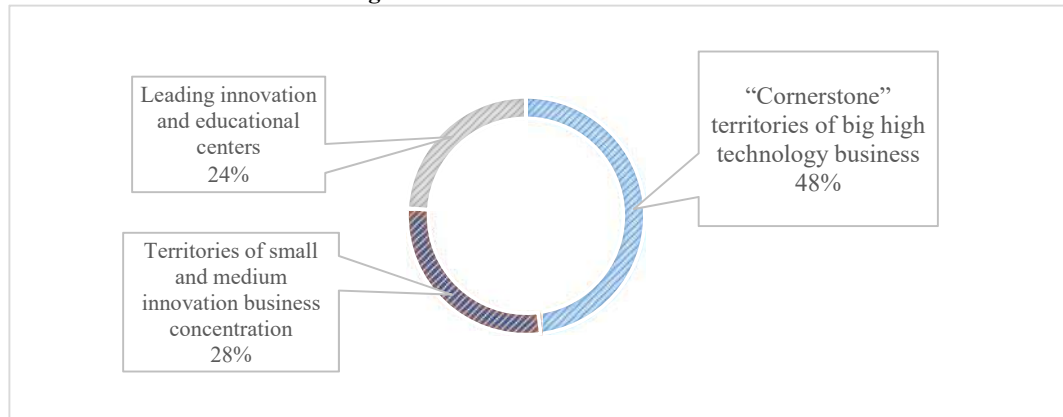

Source: compiled by the authors on the data of Russian Cluster Observatory <http://map.cluster.hse.ru/>

Nowadays cluster’s enterprises carry out activities in 17 areas of technological specialization. (Fig.2).

Fig.2 Branch Structure of Innovation Clusters

	Medicine and Pharmaceuticals, Medicine Industries	9
	Radiation Technologies	4
	Information and Telecommunication Technologies	6
	Optics and Photonics. Laser Technologies	3
	Aircraft and Spacecraft Manufacturing	4
	Engine Construction	1
	Oil and Gas Refining	3
	Automobile Industry	2
	Instrument Engineering	3
	Electronics	3
	New Materials	8
	Nuclear Technology	6
	Biotechnologies	3
	Shipbuilding	2
	Chemical Industry	3
	Power Engineering	1
	Defense Industry	1

Source: compiled by the authors on the data of Russian Cluster Observatory <http://map.cluster.hse.ru>

The indicators of pilot innovation clusters are significantly different, that allows classifying them by level of organizational development:

- Beginning level – 11 clusters;
- Medium level – 9 clusters;
- High level – 8 clusters (Fig. 3).

Fig. 3 Organisational Level of Innovation Clusters

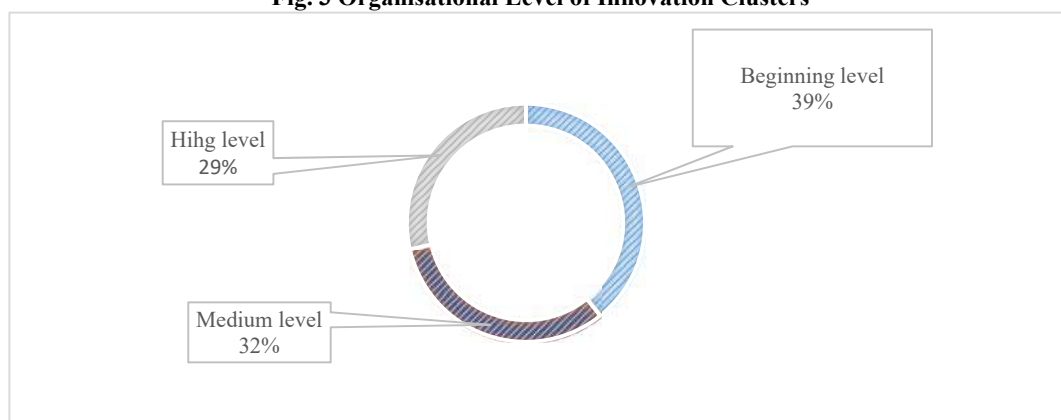

Source: compiled by the authors on the data of Russian Cluster Observatory <http://map.cluster.hse.ru/>

GOVERNMENT SUPPORT OF INNOVATION CLUSTERS

Now the government supporting of clusters are realised in the frames of the several initiatives of federal level, including:

- Programs of Ministry of Economic Development of the Russian Federation:
 - Program of Pilot Innovation and Territorial Clusters Development programs supporting of Ministry of Economic Development of the Russian Federation;
 - Program of Small and Medium Business Development;
- Programs of Development Institutions:
 - Fund of Infrastructure and Educational Programs (nanotechnological centers development),
 - Russian Venture Company and Fund (innovation companies supporting);
 - Foundation for Assistance to Small Innovative Enterprises (innovation companies supporting);
- Programs of Ministry of education and science of the Russian Federation:
 - Federal Target Programs “Research and development in priorities areas of science and technological complex of Russia in 2014-2020”
 - Program of implementation of development programs of leading universities (innovation infrastructure development)
- Programs of Ministry of Industry and Trade of the Russian Federation (supporting отдельных innovation enterprises, engineering centers).

The main mechanism of direct clusters supporting is target subsidies to the constituent entities of the Russian Federation (Resolution of the Government from 2013, March, 6 #188), where clusters are established. The finance resources can be used with the following purpose:

- Support of activities of the special organizational, which provide methodological, organizational, expert and analytic and information assistance for clusters;
- professional retraining, qualification improvement and internships for employees of cluster’s enterprises;
- consulting for cluster’s enterprises in the sphere of investment projects development;
- Exhibition organisation, and participation of cluster’s enterprises in Exhibitions, forums and other types of communicative and PR-events;
- Innovation, educational, transport, energy, engineering, social infrastructure development.

The important element of cluster development is Centers of Cluster Development, supporting by Program of Small and Medium Business Development of Ministry of Economic Development of the Russian Federation. The regional Centers of Cluster Development provided consolidation business society and government bodies on the stage of clusters established. Now they perform functions of methodological, organizational, expert and analytic and information assistance for clusters.

STRATEGIC PLANNING AND CLUSTERS

However, despite of different instruments of innovation clusters' supporting, there is important to match the strategic planning and clusters development programs.

For example, supporting of innovation and territorial clusters are implemented in 20 constituent entities of the Russian Federation, but cluster approach for strategic planning is using only in the few one.

The result of cluster approach should be development no separate branches, but the complex of industries and economic activities spheres, which generate added value and are ready to constantly renovation.

The model of cluster, which can be used in the process of strategic planning, consist of three levels:

First level – Core of cluster – enterprises, producing end items or services;

Second level – Peripherals of cluster – organisations and enterprises, providing Core of clusters by resources, and supporting their functioning. These are vendors, investment institutions, all infrastructure organisations.

Third level – Regulators – the government bodies, responsible for cluster development.

Success story: Kaluga Region

In 2009 Kaluga region adopted new Social and Economic Strategy for development until 2030 aimed at building of innovative economy, in which cluster approach was taken as base model of region development and cluster support as priority of the regional policy. Cluster creation became a mechanism of reach regional competitiveness, based on human and innovative resources.

Now there are 5 clusters in the region:

- pharmaceutical and biotechnology cluster (<http://www.pharmclusterkaluga.ru>);
- automobile cluster;
- transport and logistical cluster;
- AKOTECH - cluster of aviation and space technologies of polymer composite material and construction (<http://akotech.ru>);
- IT-cluster.

The cluster policy of Kaluga region success are based on clear investment philosophy and principles that are accepted by all government bodies.

The region offer the unique conditions for investors to locate their production in 8 industrial parks, which provide all required infrastructure, and wide specters of services. There are Greenfield and Brownfield.

The clusters development are supported by the system of institute if development:

- Corporation for Development of Kaluga Region;
- Agency for innovation development – center for cluster development of Kaluga region;
- Regional Development Agency of Kaluga region.

These institutes provide supporting to investors on the all stages innovation and clusters project realisation.

Kaluga region have an unique experience of pharmaceutical and biotechnology cluster, which became one of pilote innovation and territorial clusters in the Russian Federation. Project of Kaluga pharmaceutical and biotechnology cluster include well-balanced component. The specific feature of Kaluga Pharmaceutical Cluster is the presence of all elements required for full cycle production - from an invention, technology development and creation of original active substances to serial dosage forms production and waste disposal.

The implementation of such a scheme in the territory of Kaluga Region ensures great synergetic effect through joining efforts of business, financial, scientific and educational institutions. This in its turn is to form a solid foundation for dynamic growth of Kaluga Region economy.

Business incubators, centers for innovations and technologies, a technology transfer network and a venture fund have been established in Kaluga Region to support innovative activities in biotechnology and pharmaceutical areas. Obninsk hi-tech park facilities are being constructed. Three companies became residents of Skolkovo Center for Innovations. Scientists from Obninsk in cooperation with those companies have launched Active Molecule Park project. The project provides for development of new medicines.

Now the pharmaceutical cluster produce 7.5% of gross regional product and offer 10.5 thousand jobs, 2,2% of the regional employment. The specific of the cluster residents is their high innovation activity: more than 70% of companies.

Cluster approach is to form a solid foundation for dynamic growth of Kaluga Region economy. Its position has been improved among the other regions (Fig.4) of Russian Federation, and innovation activity increasing from 7.9% in 2011 to 9.3% in 2015.

Fig. 4. Kaluga region position change on base social and economic indicators after cluster approach implementation

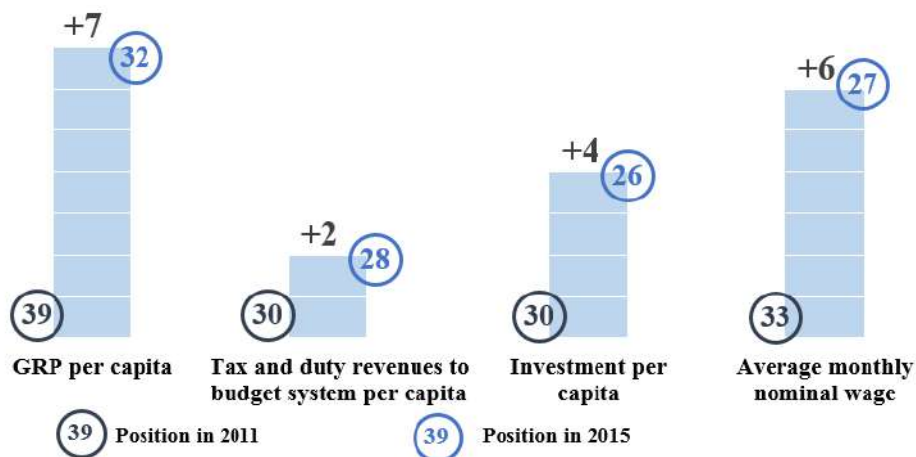

So, the implementation of cluster policy in the territory of Kaluga Region ensures great synergetic effect through joining efforts of business, financial, scientific, educational and regulation institutions.

CONCLUSION

There are many innovation clusters and mechanisms of their supporting in Russia. So, the next step to efficiency of their functioning increasing and innovation sector development is using of cluster approach in the processes of strategic planning on the federal and regional levels, including strategies and programs development. That allows getting the synergy effects for upgrade the institutional ecosystem for clusters, and for enhancing the role of clusters in the economic and social development of the territories.

Cluster approach in regional policy are on the start level in the Russian Federation, however success projects as, for example, in Kaluga region, create the conditions for dissemination of their experience and could become the base of economic growth in the regions.

SOURCES

Russia Regions. Social and economic indicators. Federal Service of State Statistic. 2012
http://www.gks.ru/bgd/regl/B12_14p/Main.htm

Russia Regions. Social and economic indicators. Federal Service of State Statistic. 2016
http://www.gks.ru/bgd/regl/b16_14p/Main.htm

Agency for innovation development – center for cluster development of Kaluga region <http://www.airko.org>

Russian Cluster Observatory <http://map.cluster.hse.ru/>

PILOT INNOVATIVE CLUSTERS IN THE RUSSIAN FEDERATION: IMPLEMENTATION OF DEVELOPMENT PROGRAMS / L. Gokhberg, A. Shadrin (eds.); National Research University Higher School of Economics. – Moscow: HSE, 2015.

CLUSTER POLICY: POTENTIAL CONCENTRATION TO REACH OF GLOBAL COMPETITIVENESS.
Report. Moscow – 2015 <http://innovation.gov.ru/sites/default/files/documents/2016/40212/5779.pdf>

Kutsenko E. (2015) PILOT INNOVATIVE TERRITORIAL CLUSTERS IN RUSSIA: A SUSTAINABLE DEVELOPMENT MODEL. ForesightRussia, vol. 9, no 1, pp. 32–55.

Leonova T.N., Artemova E.S., BASIS OF INNOVATION ECOSYSTEM FORMATION AND ITS ELEMENTS. Application statistic researches and business-analytics. Russian scientific and practical conference: materials and reports; Plekhanov Russian University of Economics, 2015.

Plotnikova G.A., Udachina M.V. SOCIAL AND ECONOMIC PROGRAMMING IN THE RUSSIAN FEDERATION: REGIONAL ASPECTS University Bulletin (State University of Management) 2012. № 20

Khasuntsev I.M., Leonova T.N., THE PROBLEM OF SECTORIAL INNOVATION SYSTEM IN ECONOMY OF THE RUSSIAN FEDERATION, Innovation and expertise: proceedings, 2014, № 2 (13)

Indicators of Innovation in the Russian Federation: 2017 : Data Book / N. Gorodnikova, L. Gokhberg, K. Ditkovskiy et al.; National Research University Higher School of Economics. – Moscow: HSE, 2017.

Abashkin V., Kutsenko E. (2014) Samara Forum- 2014: CLUSTER POLICY INSTRUMENTS SYNCHRONIZATION. <http://issek.hse.ru/news/134877420.html>

PUERTO RICO: THE SAGA CONTINUES

Frank Paul Le Veness
St. John's University
New York, USA and Rome, Italy

ABSTRACT

The island of Puerto Rico has been in a colonial status since the Europeans first landed on its shores in the late Fifteenth Century. Since that date the island's people have suffered all the political, social, and economic ills that accompany traditional colonialism. As I stated in an Abstract to a paper delivered at GBATA last year in Abu Dhabi, U.A.E., "The land is still steeped in poverty, a disastrous economy, with few apparent alternatives." Since that paper was prepared, the island's conditions have worsened, and days before this paper was submitted, the island declared bankruptcy. A review of the economy leading to this catastrophe follows.

Keywords: Dependence, economy, finance, bonds, relationship with mainland, bankruptcy.

INTRODUCTION: PLACING IT IN PERSPECTIVE

As in previous my studies of Puerto Rico, this paper relies significantly on the theoretical approach, popularized in the 1960s and beyond, known as dependency theory. This, of course, in Latin America and the Caribbean, as well as elsewhere, was popularized by Frantz Fanon among other political theorists.. Puerto Rico is, without question, a classic case of such dependence, which over the centuries has caused considerable damage to that island's society, its politics, and its economy.¹ As a matter of fact, it has often been said that the island suffers, and has continually suffered, from a "boom-bust" economy. A brief explanation illustrates the point, and brings readers to the present crisis. After World War II, the first elected governor of the island, don Luis Munoz Marin, introduced a series of policies which sought self-reliance in the economic and social development of the island and its population. These included Operation Bootstrap in the economic sector, which emphasized the island's ever-increasing infrastructural development, particularly with regard to transportation, electrification, and worker-education for industry, finance, tax abatement, and the like. The Federal government contributed very significantly as it diverted Federal funds (tariffs) collected on goods entering the island (and therefore the United States) to the island's treasury, and further eliminated all Federal excise taxes and corporate and personal Federal income taxes from monies earned from profits and wages and salaries on the island, provided that the monies were not moved to the mainland. With the initiation of Article 936 of the Internal Revenue Service code (Tax Reform Act of 1976), that last restriction was removed. Profits could be sent to the mainland without Federal taxation, and investors raced to seize opportunities.

By the early 1960s, with strained, and actually, virtually no relations between Cuba and the United States, tourism began to rapidly expand, bringing significant positions of employment as well as funds to the island's business community and, through taxation, to its government. Again, however, boom-bust, for with the current restoration of relations with Cuba, there has been a massive interest in visiting that nation, which will continue to impact tourism on the other Caribbean destinations, including Puerto Rico.

Finally, it must be noted that Governor Munoz also initiated programs such as *Operacion Serenidad*, which sought to enhance cultural aspects of the island's past, present, and future, and to deal with Puerto Rican migrants to the mainland United States. This movement of population, of course, was exacerbated during periods of recession and lack of employment opportunities on the island. However, those are subjects for a different discussion.

The main, though not the only, problem with Bootstrap was that it relied on import-export (though mostly with the mainland United States, as opposed to foreign nations). What has become known as Direct Foreign Investment (DFI) schemes, set up elaborate plans for opportunities for mainlanders to financially support and expand the local economy. This included various industries, but was especially attractive to those with labor-intensive manufacturing, as wages stood well below the minimum, and indeed, most similar wages on the mainland. Periods of relative prosperity resulted, although there remained the problem of profits being drained from the island, and with the tax incentives offered by the Puerto Rican government, a lack of revenue for public expenditures.

A major crisis struck in 1996, when the Federal government repealed Sec. 936, and once again, gradually, made all profits removed from the island subject to Federal taxation. As noted previously, “Apparently, the main reasons for the change, during a period of U.S. recession, were that it cost the Federal government a considerable loss of income, and that the positions of employment created were too few to be worth the expense” (Le Veness, GBATA 2016, citing Barry P. Bosworth and Susan M. Collins in Collins, *et al.*, 2006). This commenced a period of recession, dare one say, depression, that has continued virtually unabated until the present day. Companies, along with their labor positions fled the island, and few replacement investors were to be found. All of this was enhanced by the creation of organs of regional organization such as the North American Free Trade Association (NAFTA) and the Central American Free Trade Association—Dominican Republic (CAFTA-DR), which lowered tariffs on goods from those regions, creating competition with Puerto Rico, as well as the virtual collapse of a twin-planting scheme between Puerto Rico and Haiti, and other “out-sourcing” initiatives of the United States business communities.

PUERTO RICO’S CURRENT ECONOMIC MALAISE

As noted above, the Puerto Rican economy is mired in deep recession. In addition, it is caught in a virtually impossible to solve debt situation. The U.S. Central Intelligence Agency (CIA) reported earlier this year that the island had developed “one of the most dynamic economies” in the entire Caribbean up to the year 23006, when the system began its current spiral to virtual collapse. Since then, growth has remained in negative figures. The Agency cited several principal reasons for this malaise, with the premise that the tax reductions, which had been so vital for mainland firm investment, were being eliminated during that period and that the price of oil had risen dramatically. This is extremely important for an island such as Puerto Rico, which is fossil fuel dependent for the generation of the electricity needed to operate its manufacturing sector. CIA estimates for the island noted that according to its latest figures, 357,805 remained without electrification, which means a 91% electrification rate, in 2012 96.4% of generation was from fossil fuels. Positions of employment fell sharply, causing an exodus of the unemployed to the United States mainland. The Agency noted unemployment had risen to a high of 16% in 2011 and stood at 13.7% at the close of 2014. It concluded that at least a portion of the lack of positions of labor may be caused by the requirement that the minimum wage in Puerto Rico was currently mandated to match the Federal level for the mainland. (CIA, 2014). It should be remembered that part of the lure of Operation Bootstrap was skilled but low-paid employees. Wages naturally rose over the years, but so did the requirement that Puerto Rican minimum wages, controlled by the Federal government, had to rise, eventually approaching and finally equaling the nation-wide Federal requirement. This of course, made labor-intensive industry much less attractive on the island, and all that was exacerbated by other regions of possible “out-sourcing” of industry which became much more enticing.

The CIA suggested that the negative relationship between public income and expenses was approximately 0.5% of GDP, and that a major cause of current economic woes was the issue of public debt. It estimated that for 2016, the debt stood at 92.5% of GDP, “about \$17,000 per person.” Since the 2015 figure stood at 96.6%, that actually meant that some of the drastic savings programs initiated by the Commonwealth government were having an effect. To put this into some perspective, the agency indicated that this was “nearly three times the per capita debt of the State of Connecticut, the highest in the US.” What were the principal causes of this over-spending? According to that same source, they included “state-run schools and public corporations, including water and electric utilities.” In 2016, GDP growth was estimated at -1.8%, with \$37,700 GDP per capita. The Agency reminded readers that in 2015, then Governor Alejandro Garcia Padilla “announced that the island could not pay back at least \$73 billion in debt and that it would seek a deal with its creditors,” (CIA, 2017) a serious omen of financial crises ahead!

Addressing the “exodus” issue back in 2004, Lizette Alvarez noted that Standard & Poor’s as well as Moody’s and relabeled Puerto Rico’s then \$70 billion debt to the status of “junk,” noting the island was then suffering from “a 15.4 percent unemployment rate, a soaring cost of living, pervasive crime, crumbling schools and a worrisome exodus of professionals and middle-class Puerto Ricans who have moved to places like Florida and Texas” (Alvarez, 2014). Utilizing comparisons with which many readers may be familiar, Ms. Alvarez added that the PCI runs approximately \$15,000, “half that of Mississippi, the poorest state.” She notes that 37% of homes receive food stamps, as opposed to 22% in Mississippi, and adds the crucial fact that this “extended recession” has been worst for the middle class, who are fleeing the island in significant numbers (Alvarez, 2014). This, of course, not merely reduces the numbers of workers available, but also creates a very serious “brain-drain,” about the last thing a developing economy needs. Ms. Alvarez adds, there is great concern over future populations of the island, for the departure is exacerbated by low birth rates and a “graying” populace who will be in need of significant care. She concludes that “Of the island’s 3.67 million people, only one million work in the formal economy. The island has one of the lowest labor participation rates in the world, with only 41.3 percent of working-age Puerto Ricans in jobs.” However, perhaps her most jarring note is that “one in four works for the government” (Alvarez, 2014). How, then can the government possibly be expected to free up the resources to support such a payroll? Virtually all major tax resources may be seen to be in that downward spiral, with fewer and fewer dollars being added to government revenues from conventional sources. This poses a major reason for the vast increase in public debt. Ms. Alvarez noted that “Since 1966 factory jobs on the island spiraled from 160,000 to 75,000. Little was done to revamp the island’s economic framework. Instead, deficits climbed and pensions spun out of control.” She cited Mike Soto, head of the Puerto Rican Center for a New Economy, who stated “It was cheap and easy to borrow. It goes to the point where we tapped out what we can borrow” (Alvarez, 2014). So, once again the island is struck by FDI, in this instance by the purchase of government debts, mainly bonds from various government agencies, undoubtedly in many instances sold to investors with assurances that they are relatively safe, in the sense that they are government bonds, and therefore, there was relatively little likelihood of non-recovery of investment.

Only a few months ago, Jonathan Levin and Rebecca Spalding renewed the image of the great exodus noting that in the “Commonwealth lost 2% of population in each of [the] past three years.The natural population increase.....fell to 3,000 last year [2016] from 20,000 a decade ago, as families facing poorer economic prospects and the threat of the Zika virus put off having kids” (Levin and Spalding, 2017).

Juan Gonzalez of *The Intercept*, sort of summarized the economic woes of the island by stating: “On an island that has lost 10 percent of its population in the last 10 years, where 46 percent of the population lives below the US poverty level, where the unemployment rate is more than 11 percent, and where the labor force participation hovers around 40 percent, lawmakers in Congress have kept insisting on greater austerity from Puerto Rico’s population” (Gonzalez, 2017). His comments, of course, come from the fact that although called a Commonwealth (in Spanish *Estado libre asociado*), and having its own Constitution since 1952, in reality ultimate control of the island’s finances lay in the hands of the United States federal government. Gonzalez continues to note that as a result of the enormity of the debt, which he notes had risen to \$123 billion by May 2017, and in an effort to vastly curtail expenditures, “During the past two years, the commonwealth government has sharply raised electricity and water rates. It has increased the sales tax (now a value added tax) to 11.5 percent. It has proposed ending all pensions for new workers and cutting existing benefits by an average of 10 percent. And.....it announced the closing of 179 public schools for the coming school year. In addition, the control board has called for a \$450 million cut over the next four years to the island’s 70,000-student public university” (Gonzalez, 2017). Writing in *The New York Times*, Frances Robles has written, “The last two administrations cut tens of thousands of positions from public payrolls” and noted that among the “strategic cuts” proposed by the administration of the current governor, Dr. Ricardo A. Rossello, “is to cut government pensions by 10 percent, which will hurt retired police officers and teachers most, because they do not receive Social Security.” She added that the Governor had “acknowledged that low-income people without access to health care and parents with children in public schools would be the most vulnerable in the months ahead” (Robles, 2017). She noted, however, that the governor is in the “awkward position of being the son of one of the long line of former governors who brought Puerto Rico to its fiscal knees by borrowing and borrowing to balance budgets and to finance a bloated bureaucracy ripe with political patronage” (Robles, 2017). So clearly, there appears to be room for considerable blame to be cast upon the island’s government and well as that of the United States. Obviously, a counter-argument would be that the administrations had little choice but to borrow or take drastic actions such as “the last two administrations” employed, namely, to “cut tens of

thousands of positions from public payrolls,” which, since there were insufficient private sector positions available, meant higher unemployment, with all the negative consequences that causes. It might be noted that Carlos J. Saavedra-Gutierrez, the Puerto Rican Secretary of Labor, noted that in the past ten years, the island’s “work force” declined by about 300,000 (cited by Robles, 2017).

It would do readers well to keep in mind the words of Professor Martin Guzman when he writes, “The Commonwealth’s debt position is clearly unsustainable, and its economy will be able to recover only if it gets a fresh state. But, unlike US municipalities, Puerto Rico is not protected by the US bankruptcy code. It is well known that decentralized bargaining processes for debt restructuring often lead to disastrous outcomes, with the relief obtained being insufficient to restore debt sustainability” Guzman, 2017). So, it is at this juncture that we turn from general discussions of the economy of the island of Puerto Rico, to one of the most immediate and seemingly intractable issues, enormous, unsustainable debt and its possibilities of resolution.

PUERTO RICAN DEBT: AT THE HEART OF THE PROBLEM

Perhaps the most immediate and pressing issue facing the Commonwealth is public debt, which as indicated in the first section of this paper, appears to be nearly insolvable. CNN indicated in May that of all its creditors, the greatest amount is to *Banco Popular*, in the amount of \$12 billion, followed, clearly at a distance, among others by Microsoft, \$12 million, and Manpower \$3.2 million. By the time that the island filed bankruptcy (May 3, 2017), some twenty-two lawsuits had been filed against the Commonwealth (Wattles, 2017). The story follows. However, it becomes quite clear that the island and its government are caught between the proverbial rock and a hard place. On the one hand there was this enormous, virtually impossible, debt to repay, and on the other, there was the need to find funds to support the needs of the island. As one illustration, CNN reported that “The three main retirement systems in Puerto Rico are expected to ‘deplete’ all their assets between July and December” (Wattles, 2017).

In last year’s paper at GBATA I covered what had been an extremely vital year for the island, both with regard to its debt and the solution, if any, to this seemingly intractable problem. One of the leading issues at that time, which will be rewritten in this paper for those not familiar with last year’s presentation, is the question of bankruptcy. In short, is the island a “state” for the purposes of declaring bankruptcy, or does it fall into some other category. All recognize that it is not a state in the convention usage of the term, i.e., the same as one of the fifty U.S. states. Clearly, it is an unorganized territory with a 1952 Constitution accepted by the United States in the form of a compact, granting the island various areas of self-government. It is far too complicated to discuss the full ramifications of this status in this presentation, but several vital issues might well be noted. The following year, 1953, the US declared (in agreement with the Commonwealth government) that Puerto Rico was no longer a dependent territory as defined under Article 53(e) of the United Nations Charter. Therefore, the United States, notified the Trusteeship Council that it would no longer send annual reports on the progress of the island, as a dependency, concerning its progress toward independence. The Council, and subsequently the General Assembly, accepted that report and status, essentially stating that the island’s people, through acceptance of this constitution, had chosen a form of voluntary association with the United States. This whole procedure brings to the surface any number of constitutional and most certainly legal and political difficulties. Just for example, can an independent nation, i.e., the United States, be perpetually held to an agreement with a non-independent land which can never be altered or abrogated without the consent of the latter?

Clearly, Puerto Rico is not independent, for the U.S. Constitution applies to it, and as a matter of fact, all Federal laws that apply to states are also effective on the island, unless they are specifically excluded. Utilization of the word autonomy to this relationship is very inaccurate. . It does not take much reasoning to extrapolate a dependency relationship between the two entities, with the United States the clear patron and Puerto Rico the client.

To the immediate problem! What are Puerto Rico’s options? Can it declare bankruptcy? As discussed in last year’s presentation in greater detail, it all really depends on interpretation of two Federal bankruptcy provisions, that of 1978 (Bankruptcy Reform Act, 92 Stat.2945) and that of 1984 (Bankruptcy Amendments and Federal Judgeship Act, P.L. 98-363). An earlier bankruptcy act, the Nelson Act (30 Stat. 544, 1898) made it clear that bankruptcy possibilities were available to U.S. states and territories, including Puerto Rico. What constituted a “state” was less certain in the 1978 law, but by far the most interesting of the three was that of 1984 which stated,

“state’ includes the District of Columbia and Puerto Rico except for the purposes of who may be a debtor under Chapter 9 of this title” (cited in Ferre Saduni, 2015). Therefore, it would appear that although Puerto Rico might be considered a state for many purposes, it was not permitted to declare bankruptcy, nor, logically, would be any of its subdivisions.

As I wrote last year, the island did attempt a form of bankruptcy for its public utilities (Public Corporation Debt Enforcement and Recovery Act, June 28, P.L. 71). This legislation would have permitted various organs of the insular government which had issued bonds or were in other debt to enter into bankruptcy. However, Mary Williams Walsh noted that even that insular legislation was deemed unlawful as it would violate the provision that only the federal legislature can enact bankruptcy laws (Walsh, 2016). On June 13, 2016, the United States Supreme Court reached a decision with regard to possibilities of Puerto Rico’s bankruptcy (Commonwealth of Puerto Rico, et al., *Petitioners v. Franklin California Tax-Free Trust, et al.*, Melba Acosta-Fero, et al., *Petitioners v. Franklin California Tax-Free Trust, et al.*(Nos. 15-233 and 255. See 20016 US. LEXUS 377). Speaking for the majority, Justice Clarence Thomas affirmed that for whatever purposes the island might be considered a state, bankruptcy was not one of them. Therefore, it could not take advantage of the Federal bankruptcy laws. In short, it could not declare itself or any of its subdivisions legally insolvent.

That leads to the Government Development Bank for Puerto Rico. The Bank, which has been in operation since 1942, is established “to safeguard the fiscal stability of Puerto Rico and promote its competitiveness in order too our economy into one of the most developed economies in the world, hence, fostering the social and economic enhancement of or people. We serve a as [*sic.*] bank, fiscal agent and financial advisor for the Commonwealth of Puerto Rico and its instrumentalities” (GDB, 20117). Its subsidiaries include the Jose M. Berrocal Institute for Economics and Finance, the Puerto Rico Development Fund, the Puerto Rico Housing Finance Authority, the Puerto Rico Public Finance Corporation, and the Puerto Rico Tourism Development Fund, along with a significant number of affiliates.. Thus, it is a major provider of funding for development projects. In the “Introduction” to its website, the GDB emphasizes that “The Commonwealth of Puerto Rico, its municipalities, instrumentalities and public corporations are important issuers of tax-exempt municipal bonds, which are sold by leading securities dealers (GDB, “Introduction”).

By May 1st, 2016, the GDB did “the impossible.” It decided to fault on \$422 million of its debt which had come due that date. This was the beginning of what would obviously develop into so much more. Serious default by the Government Development Bank undoubtedly lay ahead. Congress simply had to take action, and on June 30, 2016, it passed and President Barrack Obama signed The Puerto Rico Oversight, Management, and Economic Stability Act, known commonly as PROMESA (P.L. 114-187), averting a massive GDB default scheduled for the following day. Short of a Federal bailout, which realistically did not appear on the horizon,, especially after the U.S. presidential and congressional elections of November of that year, though controversial, and certainly considered by many another indication of colonialism and its resulting dependency, this Federal action appeared to be the island’s only real hope. At any rate, creditors were held at bay, as they temporarily were prevented from further pursuing legal action against the Commonwealth and/or its subsidiaries.

PROMESA establishes a Board of Directors of seven, who are tasked with overseeing the restructuring of the Puerto Rican debt recovery. They must approve plans as presented by the island’s governor concerning debt alleviation and restructuring of the insular economy. As I stated last year, “further duties include: approving annual budgets, enforcing budgets and ordering any necessary spending reductions, and reviewing laws contracts, rules, regulations, or executive orders for compliance with the fiscal plan.’ The bill establishes procedures and requirements for Puerto Rico to restructure its debt and designates the board as the representative of the debtor. The board may instigate a procedure for debt restructuring and submit or modify a plan of adjustment” (Le Veness, 2016 in part quotes and concepts from Congress, 2016).

PROMESA commenced operations in the second half of 2016 under Executive Director Natalie Jaresko. That board “would not be accountable to the island government and would have control over Puerto Rico’s budget, laws, financial plans, and regulations.” In addition, it “has the power to force the island government to balance its budget and force a restructuring with bondholders and other creditors” if they cannot come to terms. Finally, with regard to employment, PROMESA drops the minimum wage for employees twenty-four years of age and under to

\$4.25, and stipulated that the U.S. Department of Labor regulations concerning “overtime pay for salaried workers would not apply to Puerto Rico” (Guadalupe, 2016). Under PROMESA, a joint Congressional task force was created to report on and offer suggestions concerning the economy of the island. It was to suggest new laws to “promote long-term economic growth and stability, spur new job creation, reduce child poverty, [and] attract investment in the territory” (Congressional..., 2016). That task force released its lengthy report on December 20th, entitled *Congressional Task Force on Economic Growth in Puerto Rico: Report to the House and Senate – 114th Congress*.

In a letter to Majority Leader Mitch McConnell from Jacob J. Lew, Secretary of the Treasury and Sylvia M. Burwell, Secretary of Health and Human Services dated January 17, 2017, several specific areas of need were identified. The first concerned health care, and the report noted that up to 900,000 poor residents of the island were at serious risk unless action is taken by Congress. The letter noted that Congress needed a long-term solution to the crisis in health finances and quick response is needed to avoid falling off a “Medicaid cliff.” In addition, the report addressed unemployment “and a labor force participation rate that is only two-thirds that of the U.S. average.” The two secretaries recommended the immediate enactment of a federally financed Earned Income Tax Credit (EITC), a study of which had been suggested by the Task Force. Finally, the two Secretaries stated that they agreed with other recommendations of the Task Force. “to continue authorizing Treasury to provide technical assistance to Puerto Rico.” While not quite agreeing with the Task Force’s approach to a Child Tax Credit locally-run proposal reaching a greater population, “to the extent it is a well-designed and supplements an EITC program.....” it had their agreement. They also “support the Task Force’s acknowledgement of the importance of data in benchmarking economic growth and fiscal developments....and the recommendations to improve data quality and timeliness” and they were “pleased with the recommendations on small business incentives, and the need to include Puerto Rico in funding and training programs that address Puerto Rico’s differential treatment in some Federal programs.”

Following recommendations of PROMESA, during Spring 2017, the new governor, don Ricardo A. Rossello, endeavored to strike deals with the island’s creditors. Unfortunately, his March proposals projected payments of \$800 million per year. “While in line with the board’s initial recommendation, it means the island would wind up repaying less than a quarter of what it owes by 2026” (Spalding and Levin, 2017). This was clearly not acceptable to many creditors. Since this was bound to produce massive legal claims and disputes, provisions of PROMESA ,creditors prevented creditors from taking legal action against the island for debt repayment, a provision that terminated on May 1, 2017. Two days hence, PROMESA “suddenly announced that Puerto Rico’s economic crisis had ‘reached a breaking point.’” Under PROMESA provisions, Chief Justice John Roberts of the U.S. Supreme Court appointed Federal Judge Laura Taylor Swain from New York’s Southern District to preside over the bankruptcy proceedings (Gonzalez, 2017). Essentially, this action removes decision-making about Puerto Rico’s debt from PROMESA to Judge Swain, It remains to be seen what she will decide as to the distribution of funds.

CONCLUSIONS

So the arguments rage for the stakes are truly high. Governor Rossello and supporters argue that bankruptcy is the only realistic alternative in an effort to rescue the poor of the island, to afford health care and quality education, and to improve the economy.. Creditors seek to recoup their investments, many claiming to have been misled over the issue of bankruptcy. Bailouts do not appear to be a likely solution, as President Donald Trump tweeted, “The Democrats want to shut government if we don’t bail out Puerto Rico and give billions to their insurance companies for OCare failure. NO!” (Vicens, 2017). Frankly, the future of the island appears bleak.

REFERENCES

- Alvarez, Lizette (2014). "Economy and Crime Spur New Puerto Rican Exodus." *The New York Times*, February 8 (on-line).
- C.I.A. (2017). "Puerto Rico," *The World Factbook*, Washington, DC. (Updated 13 April). (On-line).
- Collins, Susan M., et al. (2006). *The Economy of Puerto Rico: Restoring Growth*, San Juan and Washington, DC, Center for a New Economy/The Brookings Institution.
- Congress (2016). "Summary: H.R. 5278 – 114th Cong., authored by Congressional Research Service.
- "Congressional Task Force on Economic Growth in Puerto Rico Releases Status Update." (2016). *Puerto Rico Report*. September 19 (on-line).
- Ferre Sadumi, Luis A (2015). "The Puerto Rican Paradox." *Penn Wharton Public Policy Initiative*, January 07 (on-line).
- Gonzalez, Juan (2017). "Puerto Rico's \$123 Billion Bankruptcy is the Cost of U.S. Colonialism," *The Intercept*, May 9 (on-line). Quotation from an earlier bill incorporated into the 1984 act.
- Government Development Bank of Puerto Rico (2017). "Introduction>" (accessed on-line, June 02)
- Government Development Bank of Puerto Rico (2017). "Mission" (accessed on-line June 05).
- Guadalupe, Patricia (2016). "Here's How PROMESA Aims to Tackle Puerto Rico's Debt." *NBC News.com*, June 30, 2016.
- Guzman, Martin (2017). "From Bad to Worse for Puerto Rico." *Project Syndicate*. February 28. (On-line).
- Levin, Jonathan and Susan Spalding (2017). Puerto Rican Exodus Is Speeding the Island's Economic Collapse." *Bloomberg.com*, June 2. (on-line).. Material in brackets was added by this author.
- Robles, Frances (2017). "Puerto Ricans Face 'Sacrifice Everywhere' on an Insolvent Island," *The New York Times*. May 6 (on-line).
- Spalding, Rebecca and Jonathan Levin (2017). "Puerto Rico's Governor Has to Clean Up His Dad's Mess." *Bloomberg.com*. April 19. (On line).
- Vicens, A. J. (2017). "Puerto Rico Files for Bankruptcy the Day After Trump Admin Brags About Blocking Funds." *Mother Jones*. May 3 (on-line). Tweet of April 27, 2017.
- Walsh, Mary Williams (2016). "Puerto Rico Fights for Chapter 9 Bankruptcy in Supreme Court." *The New York Times*, March 22, 2016 (on-line).
- Wattles, Jackie (2017). "5 Facts About Puerto Rico's Utter Economic Misery." *CNN Money*. May 8 (on-line).

ENDNOTE

ⁱ For GBATA works of this author, see, with Samuel C. Sprunk, "Puerto Rico and the Coming Elections/Status Referendum: Real Change or More of the Same and its Impact on Regional and Global Trade," New York: 2012; "Can Small Island Agriculture Survive: A Case Study of Puerto Rico," Kruger, South Africa, 2011; with Patrick Flanagan, "The Economic Future of Puerto Rico: The Need for Radical Change," Madrid: 2008; "Puerto Rico and the Northern Mariana Islands: Models of Political and Economic Development in Associated States" (Rome, 2002).

FRAMEWORK FOR ANALYSIS OF CORPORATE POLITICAL STRATEGIES OF REGULATED FIRMS FROM A RELATIONAL AND ETHICAL PERSPECTIVE: FOCUS ON THE BRAZILIAN RAIL FREIGHT SECTOR

T. Diana L. van Aduard de Macedo-Soares
Pontifical Catholic University of Rio de Janeiro, Brazil

Rodrigo Oliveira da Silva
Universidade Federal de Juiz de Fora, Brazil

Sérgio Augusto Pereira Bastos
FUCAPE Business School, Brazil

ABSTRACT

The objective of this article is to present a framework for analysis of corporate political strategies, in a network approach where ethics is a fundamental factor, to help firms in regulated sectors, in particular the Brazilian rail freight sector. This sector has experienced many structural changes in the past two decades, with direct government control through ownership being replaced by strong oversight by regulatory agencies of companies holding public concessions. In this scenario, firms pay great attention to respond to changes in their institutional environment, mainly by using collective political strategies. However, these strategies must be exercised while observing the tenets of business ethics, as increasingly demanded by contemporary society. The analytical framework initially proposed was based on the theories of political strategy, economic regulation, networks and business ethics. A case study was conducted in one of the companies in the sector, involving triangulation of data from semi-structured interviews, public documents and records from various sources. The application refined the initial framework and provided strategic insights that would not be captured by using a traditional strategic analysis tool.

Keywords: Corporate Political Strategies, Regulated Firms, Network Theory, Business Ethics, Rail Freight Sector, Brazil.

INTRODUCTION

Like many other countries, Brazil experienced significant structural changes in the role of government in the economy in the 1990s. One of the results of these changes was privatization of state-owned companies in key sectors of the economy, with direct control being replaced by indirect oversight through institutionalized regulatory agencies. The companies in these sectors, whether newly privatized or traditionally under private ownership, have created special structures to meet the demands of these agencies and influence or mitigate the actions of the agencies or other public and political actors in the respective business sectors. The actions of firms, whether in sectors regulated by specific agencies or not, that try to influence the decisions of public actors in their own benefit or that of the sector are called political strategies in the literature (Hillman and Hitt, 1999; Hillman et al., 2004; Oliver and Holzinger, 2008; Holburn and Vanden Bergh, 2014; Nell et al., 2015).

For analysis of the political strategies of regulated firms, the Brazilian rail freight sector (BRFS) offers a set of *sui generis* characteristics. It is a sector regulated by an agency (ANTT – National Land Transport Agency) responsible for overseeing two competing transport modes: highway and railway transport. Besides this, the ANTT changed its posture regarding rail freight carriage in 2010, since when it has issued several resolutions that have significantly affected the activities of concessionaires (Sampaio and Daychoum, 2015).

To analyze the way firms react to the political market (Bonardi et al., 2006), requires understanding the various actors that interact to promote public policies. In this respect, Bastos and Macedo-Soares (2014; 2015) stress that the strategic analysis approach from a relational standpoint makes a major contribution to the construction of strategic partnerships that can capitalize on opportunities in the political market and mitigate the threats inherent to any business strategy.

The concessionaires that compose the BRFS in many situations act collectively in the political market, mainly through their trade association, the National Railway Carrier Association (ANTF), with support in some cases from the Brazilian Railway Industry Association (ABIFER), which represents producers of equipment and materials. However, firms' actions to influence public and political actors to reach favorable decisions, whether individual or collective, need to respect the ethical principles of the relations between companies and public entities, particularly in light of the rising public vigilance of honesty in business and politics and the proper use of direct or indirect public resources.

For supporting the corporate political strategies of firms in regulated sectors, especially those that hold concessions to carry rail freight in Brazil, the initial aim of this work was to propose an analytical framework, from a relational perspective, composed of a method, model and reference lists, to contribute to more effective management, by considering the institutional nuances and the need to respect ethical principles. To refine the proposed analytical framework and show the benefits of its use, we applied it (case study) to one of the companies in the sector.

THEORETICAL BACKGROUND

Studies of corporate political strategies have traditionally been supported by the following theoretical perspectives: collective action, agency, institutional, positive politics and stakeholder management (Keim and Zeithaml, 1986; Lenway and Rehbein, 1991, Schuler, 1996; Getz, 2001; Oberman, 2004; Holburn and Vanden Bergh, 2004; Oliver and Holzinger, 2008; Barron, 2011; Lux et al., 2011; Bastos, 2012; Lawton et al., 2013; Hadani et al., 2016; Mellahi et al., 2016).

In addition to these theories that are normally addressed in studies of corporate political strategies, here we also used the perspectives of networks, strategic alliances and business ethics. All these theories combined served as the foundation for the analytical framework.

The theories of collective action and positive political action are crucial for examining political strategies, because of the effects of the decisions reached by interest groups, such as trade associations (collective action), with the aim of influencing public policies in favor of legitimate interests (positive political action).

By helping to perceive the culture, values and evolution of legislation in determined societies, institutional theory sheds light on how various actors interact in the relation between the public and private spheres (Lawton et al., 2013). Likewise, stakeholder theory together with institutional theory enables a company to identify and recognize the needs of interest groups, and to assess the impact of each stakeholder directly on the company and its relations with political actors (Hill and Jones, 1992; Barnett, 2007).

As already mentioned, many corporate political actions occur through trade associations and influence networks. In this respect, the theory of social networks combined with that of political strategies (Macedo-Soares, 2002; 2011; Bastos and Macedo-Soares, 2014; 2015) allows capturing a holistic vision of the actors that compose the political influence network of a given firm, and especially to identify indicators and variables to assess the opportunities and threats of the political market.

Originally, Macedo-Soares (2002; 2011) proposed the analytical framework called “Strategic Network Analysis” (SNA) and its variation “Global SNA”, which combines relational factors with structural and organizational factors to support strategic analysis of firms that are active in strategic alliances and networks. As a derivation of this, Bastos (2012) proposed the analytical framework called “Firm Political Strategy Management” (FPSM), which includes specific constructs and variables to analyze and adjust corporate political strategies, in that case focused on the electricity distribution segment.

In the specific case of the literature related to political strategy, very few studies have examined ethical concerns involving the activities of companies to influence public and political actors (Oberman, 2004; Mantere et al., 2009; Dubbink and Smith, 2011; Dahan et al., 2013; Singer, 2013). Under this light, Oberman (2004) argued that a political strategy will satisfy the principles of ethics if it does not prevent other interested parties from participating in the decision-making process of public and political actors. For Singer (2013), the “general strategic problem of the corporation” is how to integrate political activity, competitive strategy and corporate social responsibility. In the model proposed by him, six strategic actions are taken into consideration: competitive strategy, corporate social responsibility, tax strategy, lobbying, relations with nongovernmental organizations (NGOs) and political communication.

METHODOLOGY

After reviewing the pertinent literature and analyzing the Brazilian rail freight sector (BRFS) based on information from public sources and interviews with business executives, consultants and specialists in the sector, we constructed an initial framework. In these efforts, we focused on the four main players in the BRFS, which together in 2015 accounted for about 99% of all the cargo hauled by rail in the country. We also gathered data from trade associations, user associations and the regulatory agency, ANTT.

All told, we conducted 30 interviews using a semi-structured questionnaire. The respondents were representatives of the four concessionaires and other professionals in the sector, specialized researchers and a politician (a member of the Chamber of Deputies, the lower house of Brazil’s Congress). Finally, we applied this framework in the scope of a case study of one of the sector’s concessionaires, to refine it and show the implications of its application in terms of specific insights. The next section presents the final proposed framework, the differences between it and the previous ones – SNA and FPSM - and the main considerations on its application in railroad companies.

RESULTS AND DISCUSSION

Below we describe the components of the proposed analytical framework:

- Method: steps to evaluate strategic adherence from a relational standpoint, complementing the traditional strategic approach.
- Model: visualization of the relations among the actors in the sector under investigation.
- Reference Lists: guide for capture and analysis of data

Method for application

In line with the SNA analytical framework proposed by Macedo-Soares (2002; 2011), the method applied in this study included the steps listed below. However, we also adopted the steps employed by Bastos (2012), with some modifications for the Brazilian rail freight sector and the inclusion of the ethics dimension.

- Step 1. Characterization of the organization’s political strategy;
- Step 2. Evaluation of the strategic implications of a political nature of the organizational factors;
- Step 3. Evaluation of the strategic implications of a political nature of the focal company considering corporate ethics and integrity;
- Step 4. Evaluation of the structural factors of the sector with strategic implications of a political nature;
- Step 5. Identification of the actors of the political value network of the focal company;

- Step 6. Mapping and classification of the alliances that compose the focal company's ego network;
- Step 7. Identification of the strategic political network and analysis of the implications in the levels of the focal company and its sector;
- Step 8. Analysis of the performance of the focal company, by means of its indicators;
- Step 9. Evaluation of the strategic implications of a political nature of the focal company considering corporate ethics and integrity, from a relational perspective;
- Step 10. Evaluation of the strategic adequacy of the focal company;
- Step 11. Necessary alterations in the relational or organizational factors to better adjust the strategy, if requires; and
- Step 12. Decision on the alterations in the strategic bearings – refinement, calibration or adoption of a new strategic posture, aiming to generate sustainable value, considering all stakeholders.

Conceptual model

To formulate the conceptual model, we considered the perspectives of Austin (1990), Hillman and Hitt (1999), Bonardi et al. (2006) and Bastos and Macedo-Soares (2014; 2015). Based on Austin (1990), the conceptual model focused on the interference of the macro environment of the focal company, operating in an emerging country like Brazil. Figure 3 outlines the relations among the various actors that interact in the political market (Bonardi et al., 2006; Bastos and Macedo-Soares, 2014; 2015) of firms in the BRFS.

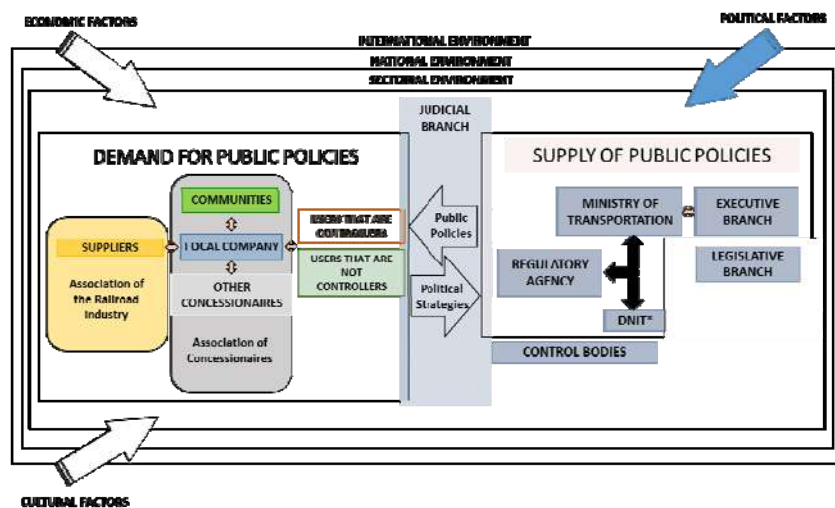

* National Transportation Infrastructures Department (DNIT)

Figure 2: Proposed conceptual model

In Figure 2 we first highlight the political factors, since the model is tailored for application in politically regulated environments. Based on the interviews and analysis of documents, we did not consider the legislative branch to be a relevant institutional actor for the employment of political strategies by firms in the sector.

With the same basis, we considered the control bodies to be among the providers of public policies for the rail freight sector because of the impact they can generate on decisions made by the regulatory agency or other members of the executive branch, especially in the process of renewal of concessions.

Reference lists

The reference lists serve to guide the data analysis. They were delineated in advance based on the literature and refined after the empirical study, with strong influence of the SNA tool (Macedo-Soares, 2002; 2011) and inspired

by and adapted from the FPSM framework (Bastos, 2012), with important contributions of national and international instruments to measure ethical management and corporate integrity.

Charts 1, 2 and 3 depict the organizational, macro-environmental and corporate ethical and integrity factors applicable to the railroad freight sector, as necessary to materialize steps 2, 3 and 4 of the delineated method.

Categories	Variables	Attributes Evaluated
<i>People</i>	Modification of the team	Properly stimulated regulatory affairs team.
		All the functional areas of the company involved in regulatory matters.
		Performance indicators involving regulation.
	Training	Instruments for ongoing training in regulatory matters.
	Competencies	Mapping and follow-up of competencies involving regulation.
		Specific management system for regulation.
		Exclusive administrative function for regulation.
		Dynamic regulatory competencies.
Experience of employees in the area of regulation.		
<i>Organizational Structure</i>	Management	Autonomy necessary for the regulation area.
	Formal structure	Specific area for institutional relationships.
		Formalization of a specific area for regulatory affairs.
		Formalization of a governmental relations area.
<i>Culture</i>	Values	The regulatory area is a necessary integral part of the daily activities.
	Leadership style	Interaction with the rest of the company.
		Recognition by the company of the regulatory function.
		Commitment of senior executives.
		Integration with the company's other business processes.
		Management level of the entire company in symbiosis with the area.
		Promotion of teamwork and gaining the confidence of people.
		Interdependent and matricial teams.
<i>Processes</i>	Business	Mapping and managing the company's activities as a macro-process.
	Regulatory	Mapping and managing the regulatory activities as a process.
	Communication	Existence of formal internal and external communication channels.
	Ethics	Communication of concerns about illegal and unethical practices.
	Anticorruption	Mechanisms to identify, deter and punish corrupt practices.
<i>Information Systems</i>	Transnational	Systems for execution of routines.
	Regulatory	Systems dedicated to regulatory activity.
	Managerial	Management systems to support decisions.
	Operational	Systems to control trains and maintenance.
	External	Supply chain integration systems.
	Ethics	Instruments for maintenance of corporate ethics and integrity.
<i>Infrastructure</i>	Transportation	Maintenance of standards of service established by the regulator.
	Suppliers	Systems to manage relations with suppliers.
	Regulator	Points of contact facilitated with the regulatory agency.
	Ethics	Incorporation of ethics as a competitive edge of the company.
	Business	Ethical attributes tied to the company's management processes.
	Service	Competencies, capabilities and resources necessary to clients.
<i>Reputation</i>	Individual	Image perceived by public and private actors in the sector.
	Protagonism	Recognition by public and private actors in the sector.
	Relations	The organization establishes responsible marketing principles.

Chart 1: Attributes of each main variable for strategic management exclusively involving organizational factors with implications of a political nature for the rail freight sector.

Categories	Variables	Attributes Evaluated
Ethics and Integrity	Code	Formalization and ample communication of ethical values.
	Competition	Mechanisms to assure fair competition.
	Public policies	Legitimacy of involvement, by preserving public discussions and access to political actors.
	Whistleblowing	Mechanisms to report irregularities.
	Investors	Transparent relationship.
	Controls	Procedures and routines to reduce vulnerability.
	Integrity program	Establishment of an integrity program involving the adoption of tools that prevent the occurrence of unlawful acts.
	Training	Promotion of a culture of integrity.
	Sponsors	Adoption of good governance practices by entities receiving sponsorship.
	Indicators	Instruments to measure the integrity program.
	Awareness	Dissemination of shared ethical values.
Governance	Governance of the organization	A decision-making system focused on achieving organizational objectives, coherent with ethical principles.
	Structure	Transparency of the structure of the company's governance bodies.
	Highest body	Capabilities defined for managers at the highest level.
Contestability	Accessibility	Instruments to assure the company's political action is just.
	Legitimacy	Legitimate adoption of practices and formation of opinion.
	Influence	No creation of barriers to the participation of other actors.

Chart 2: Attributes of each main variable for strategic management exclusively involving factors related to corporate ethics and integrity with implications of a political nature for the rail freight sector.

Categories	Variables	Attributes Evaluated
Economic	Demand	Growth of demand for railway transport.
	Users	Bargaining power of users of rail freight transport.
	Macroeconomic scenario	Growth of GDP. Variations in commodity prices.
Sociocultural	Rights of users	Perception of the preservation of users' rights.
	Respect for laws	Perception regarding laws and regulatory rules.
	Anticorruption	Public mechanisms to fight corruption.
Political	Uncertainties regarding regulation	Volume of regulatory changes.
		Level of provision for contingencies required by the regulatory agency
		Experience of the directors of the regulatory agency.
		Average duration of the process for issuing resolutions.
		Adoption of regulatory impact analysis (RIA).
		Level of rivalry among users.
		Level of rivalry among concessionaires.
		Alterations in the concession model and contract.
	Interference of political actors in regulation.	
	Ideology	Perception of the posture of the regulatory agency.
	Institutions	Perception of the stability of institutions.
Pluralism	Number of political parties.	
	Distribution of candidates elected to Congress.	
	Percentage difference in votes obtained by presidential candidates.	

Chart 3: Attributes of each main variable for strategic management exclusively involving macro-environmental factors with implications of a political nature for the rail freight sector

Chart 4 includes the types of connection between the actors perceived in the ambit of the Brazilian rail freight sector, corresponding to Step 5 of the proposed method. Charts 5 and 6 contain the indicators for the relational analysis, tailored for the BRFS, allowing materialization of Steps 6 and 7 of the method.

Type of Connection	Description
Mergers and acquisitions	One partner acquires corporate control of another partner.
Joint ventures	Partners create a separate entity.
Controller user	User is the controller of the concessionaire.
Investor user	Users that acquire equipment to haul their cargo.
Cross-participation	Each partner acquires an equity stake in the other partner.
Minority investment	One partner acquires a minority equity stake in another.
Concession contract	Resulting from a public tender (auction).
Lease contract	Period granted to operate the rail network.
Multimodal contract	Contract involving other transport modes (companies).
Adhesion to trade associations	One or more participants join sectorial associations.
Transfer of technology	Informal arrangement whereby partners share technology.
R&D contract/arrangement	Partners agree to engage in research and development of products jointly.
Equipment and materials	One or more partners supply materials to another partner.
Provision of services	One partner renders services to another partner or alliance.
Association membership	Membership in representative trade associations.

Chart 4: Description of the types of connections, in function of the degree of intensity, of rail freight carriers

Categories	Indicators	Characteristics
<i>Network structure</i>	Density	High/Low
	Scope	Ample/Restricted
	Position and centrality	Central/Intermediate/Peripheral
<i>Network composition</i>	Identity of partners of the focal industry	Strong/Weak
	Status of partners of the focal industry	Success/Failure
	Access to resources	Easy/Difficult
<i>Modality of ties</i>	Strength of the connections	Strong/Weak
	Nature of the ties	Collaborative/Opportunistic
		Obligatory/Voluntary

Chart 5: Constructs for relational analysis – industry level – for rail freight carriers

Categories	Indicators	Characteristics
<i>Network structure</i>	Density	High/Low
	Scope	Regional/National/Global
	Position and centrality in the network	Central/Intermediate/Peripheral
	Structural holes	Existence/Absence; Many/Few
	Type of tie	Invisible (private)/Visible
	Pattern of ties	Direct/Indirect
<i>Network composition</i>	Identity of the focal company	Strong/Weak; Favorable/Unfavorable
	Status of the focal company	Strong/Weak; Favorable/Unfavorable
<i>Modality of ties</i>	Strength of the connections	Strong/Weak
	Nature of the ties	Collaborative/Opportunistic
<i>Network management</i>	Governance mechanisms	Appropriate/Inappropriate
	Exchange of information	Developed yes/no
	Experience with multiples	Extensive/Not extensive
	Alignment of partners	Adequate level/Inadequate level
	Performance measurement	Appropriate/Inappropriate
<i>Management of suppliers</i>	System of suppliers	Appropriate/Inappropriate do
	Procurement practices	Appropriate/Inappropriate
	Supplier chain	Appropriate/Inappropriate

Chart 6: Constructs for relational analysis – corporate level of the focus company – for rail freight carriers

To finalize the support provided by the reference lists, Chart 7 identifies the financial and operational performance indicators for rail freight carriers in Brazil. These indicators support application of Step 8 of the

proposed method. To carry out a compared analysis, these indicators must be compared with the average of the sector.

Indicators	Interpretation
<i>Profitability Indicators</i>	
Return on assets (ROA)	Normally the higher, the better.
Return on equity (ROE)	Normally the higher, the better.
Gross profit margin	Normally the higher, the better.
Earnings per share (EPS)	Normally the higher, the better.
Price/earnings ratio (P/E)	Normally the higher, the better.
Cash flow per share	Normally the higher, the better.
<i>Liquidity indexes</i>	
Current liquidity ratio	An interval between 2 and 3 is recommended.
Quick ratio	A ratio of 1 is considered acceptable.
<i>Leverage indexes</i>	
Total indebtedness	The higher, the greater the risk of insolvency.
Debt over equity	Generally, less than 1.
Interest coverage index	Should be greater than 1.
<i>Activity indexes</i>	
Stock turnover ratio	Speed of renovation of inventory.
Receivables turnover ratio	Average period of credit for sales.
<i>Operational Indicators</i>	
Useful tones carried (UT)	Total weight of paid cargo carried.
Useful tones per kilometer (UTK)	Useful tones carried per kilometer.
Gross tones per kilometer (GTK)	Total gross weight carried per km.
UTK per train	Indicates the average production of UTK per train.
<i>Operational Safety</i>	
Causes of accidents	Identification of the reasons for accidents.
Accidents per train.km	Number of accidents per number of trains per km.
Cargo damage index	Measures the value of damaged cargo.
<i>Railway Productivity Indicators</i>	
Average commercial speed	Measured from the time of formation of the train until decoupling.
Average trip speed	Indicator of total travel time.
Utilization (%) – locomotive	Effective time of locomotive utilization
Cargo delays (%)	Measures the percentage of late delivery of cargo.
Capacity utilization index (%)	Measures the capacity utilization of the carrier.
Fuel consumption (km)	Measures the fuel consumption per km.
Costs x revenue ratio (%)	Measures the ratio between costs and revenue.
Average distance traveled – locomotive	Measures the average distance traveled per locomotive.
Availability (%) of cars	Measures the idleness of rail cars.
Average distance traveled – cars	Measures the effective utilization of available cars.
UTK produced per car	Measures the paid cargo carried per km.
UT carried per car	Measures the paid cargo carried per km per car.

Chart 7: Indicators of financial and operational performance of rail freight carriers.

Differences between the analytical framework proposed and both the SNA and FPSM

The framework proposed here innovates by including the corporate ethics and integrity dimension and by offering specific constructs, variables and indicators for the Brazilian rail freight sector, which is markedly different than the

sector investigated that served as the base for formulating the FPSM framework, and more so in relation to the SNA tool.

Most relevant considerations about applying the framework

The proposed framework was applied to one of the rail freight concessionaires in Brazil. This application produced satisfactory results, indicating opportunities and threats from the institutional environment in which the focal company is inserted, as well as identifying strengths and weaknesses, respectively to be capitalized on and mitigated.

We point out that the company in question expresses concern for ethical questions, through adoption and dissemination throughout the organization of a code of conduct, supported by regular compliance audits and establishment of a system for employees to report suspected illicit or unethical practices. It also requires suppliers to have similar compliance policies. With respect to the area responsible for regulatory questions and institutional relations, the company has a specific department for such relations, for the purpose of maintaining close ties with the regulatory agency (ANTT), Ministry of Transportation, trade associations and other stakeholders in the political market.

Based on the initial empirical findings, both from applying the framework and the responses of the interviews to ascertain the actions of companies in the sector in response to regulatory changes, we refined the proposed framework so that it more faithfully represents the nuances and particularities of the rail freight sector.

FINAL CONSIDERATIONS

Because of the singularities of regulated sectors, especially the Brazilian rail freight sector, which has been undergoing structural changes and attracting growing attention of the regulator, our aim with this study was to formulate an analytical framework to help rail freight carriers to achieve more effective management of their strategies with implications of a political nature, covering the relationship with the various relevant institutional actors and adding the question of corporate ethics and integrity, which should govern those relationships.

This framework called attention to three aspects: management of the corporate political strategies of firms in regulated sectors; identification and management of strategic relationships with a political nature; and the need to observe and maintain corporate ethics and integrity by companies in their attempts to influence public institutional actors in their own benefit or that of the sector as a whole.

The analytical tool achieved its objective of offering firms that operate in regulated sectors, notably railroad concessionaires, a framework to guide them to identify the attributes necessary to win competitive advantages in the political market while still respecting, both, the freedom of other interested parties to influence this market and the ethical limits such actions urgently deserve.

REFERENCES

- AUSTIN, J. E. **Managing in developing countries: strategic analysis and operation techniques.** New York, NY, USA: Free Press, 1990. 480p.
- BARNETT, M. L. Stakeholder influence capacity and the variability of financial returns to corporate social responsibility. **The Academy of Management Review**, v. 32, n. 3, pp. 794-816. 2007.
- BARRON, A. Exploring national culture's consequences on international business lobbying. **Journal of World Business**, v. 46, n. 3, pp. 320–327. 2011.
- BASTOS, S. A. P. **Proposta de um analytical framework na perspectiva relacional para auxílio à gestão de estratégias políticas empresariais: foco no setor elétrico brasileiro.** Doctoral Thesis. PUC-Rio/IAG, Rio de Janeiro, 2012. 316p.
- BASTOS, S. A. P.; MACEDO-SOARES, T. D. L. v. A. de. Gestão de Estratégias Públicas Empresariais: Caso Light. BBR. **Brazilian Business Review**. v. 11, pp. 67-90, 2014.
- BASTOS, S. A. P.; MACEDO-SOARES, T. D. L. v. A. Arcabouço analítico relacional para gestão de estratégias políticas empresariais face ao ambiente regulatório: foco no setor de distribuição de energia elétrica brasileiro. **Business and Management Review**, Special Issue, v. 4, n. 8, pp. 152-167. 2015.
- BONARDI, J. PP.; HOLBURN, G. L. F.; VANDEN BERGH, R. G. Nonmarket strategy performance: evidence from U.S. electric utilities. **Academy of Management Journal**, v.49, n.6, pp.1209-1228. 2006.
- DAHAN, N. M.; HADANI, M.; SCHULER, D. A. The governance challenges of corporate political activity. **Business & Society**, v. 52, n. 3, pp. 365–387. 2013.
- DAHAN, N. M.; HADANI, M.; SCHULER, D. A. The governance challenges of corporate political activity. **Business & Society**, v. 52, n. 3, pp. 365–387. 2013.
- DUBBINK, W.; SMITH, J. A political account of corporate moral responsibility. **Ethical Theory & Moral Practice**, v. 14, n. 2, pp. 223–246, 2011.
- GETZ, K. A. Public affairs and political strategy: theoretical foundations. **Journal of Public Affairs**, v. 1, n. 4, pp. 305-329. 2001.
- HADANI, M.; BONARDI, J. PP.; DAHAN, N. Corporate political activity, public policy uncertainty and firm outcome: a meta-analysis. **Strategic Organization**, pp. 1-29, June 2016.
- HADANI, M.; DAHAN, N. M.; DOH, J. PP. The CEO as chief political officer: managerial discretion and corporate political activity. **Journal of Business Research**, v. 68, n.11, pp. 2330–2337. 2015.
- HADANI, M.; SCHULER, D. A. In search of El Dorado: the elusive financial returns on corporate political investments. **Strategic Management Journal**, v. 34, n. 2, pp. 165-181. 2013.

- HILL, W. L.; JONES, T. M. Stakeholder – agency theory. **Journal of Management Studies**, v. 29, n. 2, pp. 131-154. 1992.
- HILLMAN, A. J.; HITT, M. A. Corporate political strategy formulation: a model of approach, participation, and strategy decisions. **Academy of Management Review**, v.24, n.4, pp. 825-842. 1999.
- HILLMAN, A. J.; KEIM, G. D.; SCHULER, D. Corporate political activity: a review and research agenda. **Journal of Management**, v. 30, n. 6, pp. 837–857. 2004.
- HOLBURN, G. L.; VANDEN BERGH, R. G. Influencing agencies through pivotal political institutions. **The Journal of Law, Economics, & Organization**, v. 20, n. 2, pp. 458-483. 2004.
- HOLBURN, G. L.; VANDEN BERGH, R. G. Integrated market and nonmarket strategies: political campaign contributions around merger and acquisition events in the energy sector. **Strategic Management Journal**, v. 35, n. 3, pp. 450–460. 2014.
- KEIM, G. D.; ZEITHAML, C. PP. Corporate political strategy and legislative decision making: a review and contingency approach. **The Academy of Management Review**, v. 11, n. 4, pp. 828-843. 1986.
- LAWTON, T.; MCGUIRE, S.; RAJWANI, T. Corporate political activity: a literature review and research agenda. **International Journal of Management Reviews**, v. 15, n. 1, pp. 86–105. 2013.
- LENWAY, S. A.; REHBEIN, K. Leaders, followers, and free riders: an empirical test of variation in corporate political involvement. **Academy Management Journal**, v. 34, n. 4, pp. 893-905. 1991.
- LUX, S.; CROOK, T. R.; WOEHR, D. J. Mixing business with politics: a meta-analysis of the antecedents and outcomes of corporate political activity. **Journal of Management**, v. 37, n.1, pp. 223-247. 2011.
- MACEDO-SOARES, T. D. L. v. A. Ensuring Dynamic Strategic Fit of Firms That Compete Globally in Alliances and Networks: Proposing the Global SNA - Strategic Network Analysis - Framework. **Revista de Administração Pública**, v. 4, n.1, pp. 67-105, 2011.
- MACEDO-SOARES, T. D. L. v. A. Strategic alliances and networks: conceptual tools for strategic assessments. In: **Readings Book of GBATA International Conference**, Rome, v.1, pp.292-305, 2002.
- MANTERE, S.; PAJUNEM, K.; LAMBERG, J. A. Vices and virtues of corporate political activity: the challenge of international business. **Business & Society**, v. 48, n. 1, pp. 105-132, 2009.
- MELLAHI, K.; FRYNAS, G. J.; SUN, PP.; SIEGEL, D. A review of the nonmarket strategy literature: toward a multi-theoretical integration. **Journal of Management**, v. 42, n.1, pp. 143–173, 2016.
- NELL, PP. C.; PUCK, J.; HEIDENREICH, S. Strictly limited choice or agency? Institutional duality, legitimacy, and subsidiaries’ political strategies. **Journal of World Business**, v. 50, n. 2, pp. 302–311, 2015.
- OBERMAN, W. D. A framework for the ethical analysis of corporate political activity. **Business and Society Review**, v. 109, n. 2, pp. 245–262. 2004.
- OLIVER, C.; HOLZINGER, I. The effectiveness of strategic political management: a dynamic capabilities framework. **Academy of Management Review**, v.33, n.2, pp.496-520. 2008.

OLSON, M. **The logic of collective action**: public goods and the theory of groups. 2nd ed. Cambridge, MA: Harvard University Press, 1971. 208p.

SAMPAIO, PP. R. PP. et al. Regulatory reform in the Brazilian railway sector – a preliminary assessment. **Network Industries Quarterly**, v. 17, n. 3, pp. 14 – 16. 2015.

SCHULER, D. A. Corporate political strategy and foreign competition: the case of the steel industry. **Academy of Management Journal**, v. 39, n. 3, pp. 720-737. 1996.

SINGER, A. E. Corporate political activity, social responsibility, and competitive strategy: an integrative model. **Business Ethics: A European Review**, v. 22, n. 3, pp. 308 – 324. 2013.

COMPETITIVE BUSINESS INTELLIGENCE AND ANALYTICS SYSTEMS: A STRATEGY FOR SMME ORGANIZATIONS

Nelson Sizwe Madonsela, Kehinde Sobiya and Bhakisipho Twala
University of Johannesburg, South Africa

ABSTRACT

Today, both the management of organizations and the public sector depend on real-time information, particularly accurate information, for decision making. Most industries realize that the business environment is so complex because of the influx of data from multiple sources, which needs to be collected, stored, analyzed, protected and utilized for better decision making. Industries find it challenging to stay adaptive in such an environment and rely on information they collect to make executive decisions. From a business perspective, data has become an asset for competitive advantage. Accordingly, nowadays industries are adopting business intelligence and analytics (BI&A) systems to mine data from multiple sources in order to make well-informed business decisions. The emphasis on BI&A systems derives from the ability of BI&A tools, technologies, practices, methodologies and applications to provide real-time accurate information and predict the future, which leads to better decision making. This information can be related to customers, competitors and the business environment itself. It is believed that Small, Medium and Micro-sized Enterprises (SMMEs) are reluctant to adopt such technologies owing to the perception that BI&A systems are very expensive and require expertise that they lack. The study reported on in this paper suggests a strategy for SMMEs that will allow them to adopt competitive BI&A systems as a sustainable business strategy. The study demonstrates different approaches to the adoption of BI&A systems and addresses inaccurate perceptions of BI&A, such as that BI&A technologies are more costly than other technologies. A scientometrics analysis of BI was conducted using a theory of knowledge for literature reviews in the IS domain. The findings suggest that competitive BI&A systems exist in the majority of large-sized businesses, while SMMEs still struggle to implement or adopt BI&A tools. As a result, these businesses are seeking appropriate ways of integrating BI&A tools that are more applicable to their business nature. The study also shows the need for developing strategies that can enable SMMEs to adopt BI&A systems. Therefore, this study proposes strategies for SMMEs to use in adopting BI&A tools to enhance competitiveness.

Keywords: competitive intelligence, business intelligence systems, business analytics, small business enterprises, decision making, information analysis, decision support systems, knowledge discovery process, knowledge management.

INTRODUCTION

Organizations' management and the public sector depend for their decision making on real-time information, particularly accurate information. Most industries realize that the business environment is as complex as it is because of the influx of data from multiple sources. This data needs to be collected, stored, analyzed, protected and used for better decision making. It is certain that industries find it challenging to stay adaptive in such an environment and rely on information they collect to make executive decisions. From a business perspective, data has become an asset for competitive advantage. Accordingly, nowadays industries and the public sector are adopting business intelligence and analytics (BI&A) systems to mine data from multiple sources to make well-informed decisions. Over the past decades the South African government has addressed issues of unemployment, underemployed and equity, which even today present a challenge. The perception exists that small, medium and micro enterprises or SMMEs could be key players in addressing some of these issues. In fact, SMMEs have been emphasized as a pillar for sustaining economic growth by large economies such as New Zealand, Nigeria, Greece, the Czech Republic, Turkey and Malaysia, to name but a few. For example, in Turkey 77 percent of the Gross Domestic Product (GDP) is contributed by SMMEs. In South

Africa SMME contribution is at 63 percent while the private sector contributes 60 percent (Dilver, 2015). It is not surprising then that South African academics are paying serious attention to SMMEs. This is evident from the increasing number of studies regarding SMMEs, with a particular emphasis on the adoption and use of Business Intelligence (BI) to sustain competitive intelligence in the SMME sector. It is almost certain that South Africa is not lagging behind in terms of understanding the importance of BI. However, while Boonsiritomachai, McGrath and Burges (2014) strongly argue that in the highly competitive marketplace making effective and instant decisions requires BI applications, Grabova (2010, in Horakova and Skalska, 2013, p.50) is of the opinion that the “high price for BI tools, difficult implementation and complex deployment are the reasons, why small and medium-size businesses are seeking for their solutions” rather than adopting BI tools. With SMMEs in South Africa significant from both the government and researchers’ perspectives and consensus that SMMEs can play a role in reducing poverty, addressing job creation and strengthening economic growth – it is important to address the hindrances that prevent SMMEs from using BI systems. In 1995, the South African government released a White Paper on National Strategy for the Development of Small Business in South Africa, which suggested that the hindrances to SMME sustainability are a lack of skills and admittance to suitable technology along with poor infrastructure and policies. Chimucheka and Mandipaka investigated the challenges faced by SMMEs, discovered that there is a “lack of support from key stakeholders” (2015, p.309). There is sufficient evidence that these issues need a collective approach from all stakeholders such as government and the private and public sectors, along with academics, who we believe are experts in understanding some of these hindrances. This paper addresses the technological aspect by proposing a strategy for SMME organizations through the lens of competitive BI&A systems or applications. The study intended to establish approaches that SMMEs can utilize to take advantage of these advanced tools to forecast or predict the future to strategize on how to drive improvement. The paper also addresses the perception that BI&A tools are expensive and complex to deploy. The paper has been structured into five main parts, beginning with the introduction, which highlights the importance of SMMEs in both developed and developing economics and presents the problem statement and the rationale for the study. The second part, the literature review, provides the theoretical framework that informs the proposed competitive BI&A systems. The third part of the paper concerns the methodology adopted for this study. The fourth part highlights the findings and the paper concludes with recommendations for future research.

PROBLEM STATEMENT

SMMEs appear unable to sustain business in South African despite the support provided by government, such as incubator programs and financial assistance. This inability can be associated with the lack of knowledge management and use of advanced technologies as evidenced by the high failure rate, with Chimucheka and Mandipaka observing in 2015 that 70 percent of SMMEs fail within three years. Clearly this raises a serious concern as well as the question: where are the stakeholders? As academia what can we do to assist the SMME sector? Because in the 21st century era the business environment is volatile and “pressures to accelerate performance have led many organizations to enhance their performance management practices and adopt Business Intelligence and Analytics technology to improve decision making process” (Abi, Yahaya & Deraman, 2015, p.5), it is vital to play our part as BI&A experts with the belief that the proposed strategy might address some of the issues. In addition, the paper enlightens SMMEs about several approaches that can be of assistance with regard to competitive intelligence and sustainable business advantage.

SIGNIFICANCE OF THE STUDY

The study is vital for the development of strategy that will enable SMMEs to strengthen their competitive advantage and for innovation to generate new ideas that will lead to sustainability. Equally, this approach might have a significant impact on job creation and poverty alleviation and consequently enhance economic growth. It has been noted that some business owners fall short of adequate skills for managing for quality and performance excellence. Thus, the proposed strategy aims at incorporating experts that will empower SMMEs. The University of Johannesburg academics have already started a project that puts this into practice in Soweto, the largest township in South Africa. In this project, university graduates are involved in their community, empowering the business owners of sewing cooperatives. On the basis of the growth of researchers in BI, it can be said that South African researchers can definitely provide the necessary expertise to strengthen SMMEs.

LITERATURE REVIEW

The literature review was conducted in the form of a scientometric analysis in which the researchers mapped the progression of BI over the past 40 years using the Scopus database. Prakash and Nirmala (2015) define scientometric analysis as an empirical study of a field's literature, which entails the quantification of the published knowledge. Cronin, Ryan and Coughlan (2008, p.39) concede the usefulness of such an approach but specify that "systematic review should detail the time frame within the literature was selected, as well as the methods used to evaluate and synthesize findings of the studies in question". Mapping the progression of BI broadens the understanding of the BI application usage and establishes what industries are using BI&A systems. In addition, the scientometric analysis indicates the areas that have been adequately addressed and the aspects that have been overlooked or understudied, in order to identify a gap in the literature. The study adopted Levy and Ellis's (2006) systematic approach to conducting an effective literature review within the IS domain, which was incorporated within the scientometric analysis. These authors argue that an effective literature review "creates a firm foundation for advancing knowledge. It facilitates theory development, closes areas where a plethora of research exists, and uncovers where research is needed" (2006, p.182). As a result, this "input-processing-output" approach of Levy and Ellis (2006) was integrated into the scientometric analysis.

a) Business Intelligence and Analytics

Kumari (2013, p.969) defines BI "as the ability for an organization to take all its processes and capabilities and then convert these into knowledge, ultimately getting right information for the right people, at the right time, through the right channel". The key words in the above definition are knowledge and information. We are of the opinion that SMMEs lack knowledge management and the ability to access accurate information for better decision making. Concerning the progression of the BI field, there has been a significant progression in terms of the empirical studies in different sectors such as finance, agriculture, health, the public sector and the private sector, to name but a few.

Different meanings have been assigned to BI. For example, according to Nedelcu (2013, p.12), BI "presents a wide area of applications and technologies for collecting, sorting, analyzing and providing access to information for improving process modeling quality". Joseph (2013) is of the opinion that BI encompasses the technologies and applications that enterprises can use for data collection, storing and analyzing for better decision making. In contrast, Dawson and Belle argue that BI is more than the multiple tool but "the effective deployment of organizational practices, processes, and technology to create knowledge base that supports the organization" (2013, p.2). In other words, BI focuses on exploring a vast amount of data from multiple sources and analyzing it for accurate decision making. However, it cannot predict the future. The complexity of the economic environment is constant changing thanks to the "accelerating pace of change, globalization, information flow, new economy, networking and proactivity" (Pirttimaki, 2007, p.2). Such an evolving environment requires advanced tools that can forecast the future, so it is not surprising that the IS domain introduced the concept of analytics. Analytics "refers to the skills, technologies, applications and practices for continuous iterative exploration and investigation of data to gain insight and drive business planning" (2015, p.2). As BI is limited to addressing these drivers, recent studies advocate the merging of BI and analytics to achieve BI&A in order to address the deficiency. It is certain that the BI field has progressed significantly and has integrated other fields such as business analytics and advanced analytics. The graph depicted in Figure 1 below shows the cumulative growth of the BI field over the past 40 years according to the Scopus database, which indicates that 4,807 journals were published in the field. Attachment 1 presents a table of the cumulative data. In recent years, BI has gained popularity in academia as well as the industries.

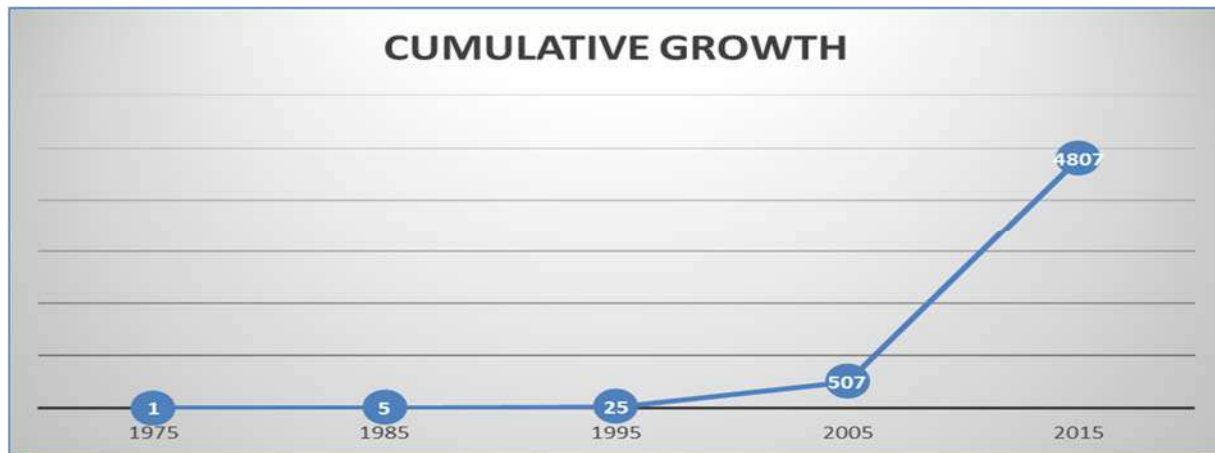

Figure 1: The cumulative growth of BI over the past 40 years

The cumulative growth shows that there is an increasing interest in BI; hence, these studies have been conducted from various industries as mentioned earlier. Today businesses focus on BI&A for sustainable competitive advantage or for survival. According to Chen, Chiang and Storey (2012), over the past two decades the academic and business communities have been paying serious attention to the concept of big data, which is linked to BI&A. These authors define BI&A “as the techniques, technologies, systems, practices, methodologies, and applications that analyze critical business data to help an enterprise better understand its business and market and make timely business decisions” (2012, p.1166). The BI&A approach is useful because it advocates that SMMEs integrate these key elements, considering that the unpredictable business environment requires real-time data. In fact, accurate data failure can be detrimental. Therefore, this study argues that competitive BI&A systems are the appropriate strategy for the SMME sector to adopt in order to flourish in the current economic environment and to build a culture of sustainable competitiveness.

b) Business Intelligence and Analytics in SMMEs

The SMME sector is one of the multiple pillars of economic growth in both developed and developing economies. In particular, the South African government has been promoting the development of SMMEs through incubator programs that foster entrepreneurship in most of the country’s townships. This is evidenced by the release of the White Paper on National Strategy for the Development and Promotion of Small Business in South Africa, which highlights the policy and strategy framework for the sustainability of SMMEs. In addition, the White Paper acknowledges the challenges that have been hindering the advancement of this sector, equally, proposing a collective strategy that will strengthen it along with the economic growth of the entire country. In fact, many economies such as Turkey, Nigeria, the Czech Republic, Spain, Malaysia and Australia are paying serious attention to the SMME sector, with a particular focus on the adoption of technology and specifically BI (Cuyvers et al., 2008; Horakova & Skalska, 2013; Boonsiritomachai, McGrath & Burgess, 2014; Dilver, 2015; Chimucheka & Mandipaka, 2015; Hatta, Mikson, Ali, Abdullah, Ahmad, Hshim, Alias, Maarof, 2015; Antoniadis, Tsiakiris & Tsopogloy, 2015). Accordingly, Cuyvers, Dumount, Viviers, Pelsmacker, Muller, Jegers and Saayman (2008) claim that competitive intelligence associated with BI enables businesses to predict competitors and gain strategic advantage. Horakova and Skalska (2013) suggest that crucial to the adoption of BI by SMMEs is job creation. These authors contend that “usage of BI among the small and medium enterprises is going to increase in the future as software vendors start to focus on this market segment”(2013, p.51). Meanwhile those SMMEs that adopt BI will be able to enhance productivity and innovation. Interestingly, BI is covered by a broad spectrum of industries such as manufacturing, health services, telecommunication, and IT companies, the banking sector and insurance industry to name but a few (Horakova & Skalska, 2013). As a result, researchers have provided sufficient framework and theories for the adoption and usage of BI&A by SMMEs, which shows that those theories have been thoroughly covered, in fact, in both developed and developing economies.

Yet, there are still challenges with the sustainability of SMMEs, which we believe are associated with the inability of SMMEs to incorporate an enabling infrastructure that embodies elements of continuous and relevant improvement. At this point, we would like to subscribe to the KPMG (2016) notion that businesses adopt BI&A tools to establish a better understanding of the economic environment they operate in. In fact, a better understanding of the economic environment can be expected to enhance the knowledge diffusion and the BI capabilities, in particular with the assistance of BI experts.

METHODOLOGY

An empirical study design of a literature review using a scientometric analysis of the BI field over the past 40 years was adopted. This is viewed as a systems approach to conducting an effective literature review within the IS domain. These methods are covered in the previous section. The Scopus database was selected as one of the largest databases in the world to establish the progression of BI and to identify the underpinned theories and the gaps in the literature. According to Scheryen, Wagner and Benlian (2015), it is imperative to build theory from an epistemological model of a domain. Likewise, the study employed a theory of knowledge for literature reviews, which derives from the IS discipline. These methods were used to triangulate the study and to ensure relevancy by considering journals published under the IS domain.



Figure 2: Epistemological model

Figure 2 depicts the epistemological model adopted for the literature review. The synthesis stage entails the establishment of the concepts, sub-concepts and variables of the understudied field, with particular focus on the domain to institute the relationships. The “adopting a new perspective” stage interprets the relationships of the concept to articulate the findings with the aim of generating a new perspective of what has been overlooked. A researcher can thereafter build new theories and test them. The next stage is to identify research gaps, which is vital for adding value to the body of knowledge and the domain. Lastly, the providing of a research agenda entails suggestions for future research that the study could not cover. In accordance with the aims of the study, the epistemological model was applied.

RESULTS AND DISCUSSION

The SMME sector has become a main pillar of economic growth for both developed and developing economies, with the notion that this sector can address issues associated with poverty, unemployment and underemployment. We have observed the significant increases of study aimed at determining strategies, framework, policies, and regulations to create an enabling environment for the development and promotion of SMMEs in South Africa. In fact, worldwide, economies are paying serious attention to SMMEs for sustainable economic growth. Equally, academia has been investigating best practices, technologies, and techniques that are appropriate for the sector as well as identifying the shortfalls of the sector and proposing solutions. However, these solutions need to be contextualized by country due to environmental dynamics, which involve constraints that economies must address locally. Thereafter, it will be appropriate to integrate new approaches such as BI&A with the acquisition of talent and nurturing of entrepreneurship.

In terms of the adoption and usage of BI&A, seemingly there has been extensive awareness and emphasis on these within SMMEs and businesses generally. Studies have shown that competitive intelligence enables enterprises to make better decisions and improve business performance. However, there are still challenges with the required skills, limited policy, and knowledge management by SMMEs. From this perspective, we propose the engagement of academia to address some of these challenges as we believe that academic institutions have the capabilities to provide the appropriate solutions. It has been shown that business environments and economic environments are constantly changing thanks to the advancement of technology. Therefore, SMMEs need to adapt or they will become obsolete. A KPMG study recommends that businesses need to “keep track of the operational aspects of running the business, while continuously innovating and striving for new business models to change and renew the business in order to say ahead” (KPMG, 2015, p.1). Being able to incorporate these views means that SMMEs need to adopt competitive BI&A systems as a strategic management policy. Abai, Yahaya and Deraman (2015, p.5) concede that managing business performance requires BI&A to “ensure management is constantly alert of any instability of achievements”. It is possible that BI&A tools address the high failure rate of SMMEs because, with the warning systems they incorporate, the owner can predict challenges and implement interventions. Furthermore, these authors assert that performance management practices are the key to business sustainability. At this point, we would like to raise some objections that might come to mind for skeptical readers. They may think, for example, that we have overlooked the objection that these BI&A tools are expensive. In fact, there are open source programs that the SMMEs can adopt, which simply require customization. With the involvement of academics, experts in BI&A may be a successful intervention that might cost less. Meanwhile these graduates have the opportunity to highlight their talent. This approach has been adopted by many developed economies such as Britain and the United States of America in their manufacturing sectors. Accordingly, the SMME sector could adopt the same approach rather than relying on strategies that are not sustainable. Of course, researchers might challenge this philosophical thinking while neglecting the deeper problem of decolonization of knowledge. We need to reassess the relevance of our theories rather than replicating practices and policies without enabling infrastructure. In this particular study, what informed the researchers was the progression of studies of BI adoption and usage within SMMEs in South Africa. Reverting to our methodology, specifically the epistemological model, we noted a research gap in the experimental or simulation aspects of these BI&A tools in SMMEs. Hence, a study within the public sector has been initiated in which open source software has been identified for simulation to encapsulate the view of the citizen in terms of service delivery. To summarize, the current economic era is an era of competitive BI&A. Experts inform us that BI&A derives from analytics that have been revised to advanced analytics with capabilities of automatic knowledge discovery from structured and unstructured data (RapidMiner, 2015). While that is a high level of analytics, which might be difficult for SMMEs to comprehend now, it is an excellent tool for future prediction.

CONCLUSION AND RECOMMENDATIONS

This paper aimed at exploring the competitive BI&A systems as a strategy for South African SMMEs. The adoption and usage of BI&A are imperative for these SMMEs in order for them to establish a broader understanding of business environment dynamics and to identify advanced strategies that address the challenges associated with business sustainability. Considering the high failure rate of startup SMMEs and the fact that SMMEs are one of the main contributors to GDP in a large number of countries, a comprehensive literature review was conducted using a scientometric analysis of the BI field with the notion that SMMEs around the globe are turning to these advanced technologies for competitive advantage. Findings suggest that, with BI, SMMEs can integrate multiple processes and business capabilities into knowledge for better decision making. The current unpredictable business environment demands the right information at the right time. Along these lines, applications and technologies have the capabilities of collecting, sorting and analyzing for better decision making as they focus on exploring vast amounts of data from multiple sources and analyzing it for accurate decision making. However, these systems cannot predict the future. The study also revealed that there has been a significant progression in terms of empirical studies in different industries such as finance, agriculture, health, and the public sector and private sector, to name but a few. We have also noted the emerging of BI and analytics, introducing the new concept of BI&A to address the limitations of BI. It is worth mentioning that the study showed an increase in South African

research on BI&A, in particular within SMMEs. However, these are shortcomings pertaining to the execution of the implementation of BI&A in a South African context. Therefore, future research should focus on the technical and skills deployment aspects of BI&A with the incubator programs to empower SMMEs with adequate skills to use these technologies. This strategy might address the high failure rate of SMME startups as well as sustaining the existing ones. Although the South African government has been building enabling infrastructure for SMMEs, skills deployment still presents a challenge, especially regarding the use of BI&A. In fact, there has been a lot said about the advantages of BI&A, with less mentioned about practical implementation, which could be the reason for the high failure rate of BI&A implementation. This still needs to be investigated.

REFERENCES

- Dilver, S. (2015). The adoption of new technology : A case of small , medium and micro-sized enterprises (SMMEs) in South Africa and Turkey. *Journal of enterpreneurship and innovation management*, 3(3), (pp. 129-143)
- Boonsiritomachai, W., McGrath, M., Burges, S. (2014). A research framework for the adoption of Business Intelligence by Small and Medium-sized enterprises. *Proceedings of the Small Enterprise Association of Australia and New Zealand*, 16-18 July, 2014 (pp. 1-22). Sydney.
- Prakash, K., Nirmala, B. (2015). Research trends in forensic science. A study of scientometric analysis. *International Journal of Research in Library Science*, 1(2), (pp. 42-48)
- Prakash, K., Nirmala, B. (2015). Research trends in forensic science. A study of scientometric analysis. *International Journal of Research in Library Science*, 1(2), (pp. 42-48)
- Nedelcu, B. (2013). Business Intelligence Systems. *Database Systems Journal*, 4(4), (pp.12-20)
Joseph (2013)Grabova 2010
- Cuyvers, L., Dumount, M., Viviers, W., Pelsmacker, P., Muller, M., Jegers, M., Saayman, A. (2008). Export intensity and the competitive intelligence of exporting companies: Evidence from South African. *South Africa Journal Economic Management Science*, 11(1)
- Scheryen, G., Wagner, G., Benlian, A. (2015). Theory of knowledge for literature reviews: An epistemological model, taxonomy and empirical analysis of IS literature. *Proceedings of international conference on information systems*, Fort Worth , 2015, (pp. 1-19)
- Hatta, N.N., Mikson, S., Ali, N.M., Abdullah, N.S., Ahmad, N., Hshim, H., Alias, A., Maarof, M.M. (2015). Business intelligence system adoption theories in SMEs: A literature review
- KPMG. (2015). Business Intelligence & Analytics. Retrieved June 17, 2016, from
- Horakova, M., Skalska, H. (2013). Business intelligence and implementation in a small enterprise. *Journal of Systems Integration*, 2, (pp. 50-62)
- Chimucheka, T., Mandipaka, F. (2015). Challenges faced by small, medium and micro enterprises in the Nkonkobe municipality. *International Business & Economics Research Journal*, 14(2), (pp. 309-316)
- Cronin, P., Ryan, F., Coughlan, M. (2008). Understanding a literature review: a step by step approach. *British Journal of Nursing*, 17(1), (pp. 38-43)

Levy, Y., Ellis, T.J. (2006). A systems approach to conduct an effective literature review in support of information systems research. *Informing Science Journal*, 9, (pp. 181-202)

Kumari, (2013)

Pirttimaki, V.H. (2007). Conceptual analysis of business intelligence. *South African Journal of Information Management*. 9(2).

Chen, H., Chiang, R.H.L., Storey, V.C., (2012). Business intelligence and analytics: from big data to big impact. *MIS Quarterly*, 36 (4), (pp. 1165- 1188).

Antoniadis, I., Tsiakiris, T., Tsopoglo, S (2015). Business intelligence during times of crisis: adoption and usage of ERP systems by SMEs. *Proceedings of International Conference on strategic innovative marketing*, 1-4 September, 2014 (pp. 299-307), Madrid, Spain.

Abai, N.H.Z., Yahaya, J., Deraman, A. (2015). Managing business performance using business intelligence an analytics. *Proceedings of International conference on Electronics Systems and Information Technology*, 14-15 March, 2015, Dubai, UAE

RapidMiner. (2015). An introduction to advanced analytics.

THE IMPACT OF SYSTEM CHARACTERISTICS ON DECISION-MAKERS' ATTITUDE TOWARDS THE ADOPTION OF MOBILE MARKETING

Daniel K. Maduku
University of Johannesburg, South Africa

ABSTRACT

Research on the association between innovation characteristics and the adoption of the mobile marketing innovation at the small and medium-sized enterprise (SME) interface is limited. This study examined the direct impact of the innovation characteristics on South African SME decision-makers' attitude towards the adoption of mobile marketing. Data for testing the research hypotheses formulated for the study were obtained through a survey of 156 manufacturing SMEs in the Gauteng Province of South Africa. The findings suggest that relative advantage, compatibility, and the complexity of the mobile marketing innovation are all significantly associated with SME decision-makers' attitude towards adopting this source of innovation. The managerial implications of these findings for strategies aimed at accelerating the adoption of mobile marketing among South African SMEs and others operating in similar contexts are highlighted.

Keywords: Mobile marketing, innovation characteristics, Small and medium-sized enterprises (SMEs), South Africa.

INTRODUCTION

Innovations create opportunities and challenges for business. One such innovation that is creating profound opportunities for businesses is mobile media (Kaplan, 2012). Originally designed to facilitate interpersonal communication, mobile technology has been leveraged to streamline and improve many aspects of business functions, including marketing. The use of mobile technology to perform marketing functions is called "mobile marketing". Mobile marketing is thus defined as "a set of marketing practices that use wireless mobile technologies and networks to create personalised and interactive communication between an organisation and its target audience, resulting in value creation for both parties" (Maduku, 2016:55).

Mobile marketing comes in several forms, including text messaging, integrated content, WAP sites, interactive voice response, geo-targeting, viral marketing, mobile broadcast advertising, cell phone sponsorships, and mobile telemarketing (Lamarre, Galarneau & Boeck, 2012; Shankar & Balasubramanian, 2009). The mobile marketing platform is uniquely attractive to marketers due to its 'always present', 'always on', and 'always connected' nature. These attributes are said to offer unrivalled opportunities for ubiquitous personalised communications (Johnson & Plummer, 2013).

Mobile marketing helps small and medium-sized enterprises (SMEs) to ensure a precise focus on customer value by providing personalised communication offers to their target market that would otherwise not be available to them (Yan & Chew, 2011). With mobile marketing, SMEs can design personalised marketing programmes to promote sales and specials and to initiate contests and polling, thus attracting customers and making much-needed sales that will promote their survival and profitability. It is argued that the successful implementation of source-technologies such as mobile marketing in SMEs would be positively associated with performance and growth.

In spite of these benefits, studies have shown that most businesses – particularly SMEs – have been slow to rebalance their marketing efforts to take advantage of the opportunities provided by mobile media (MMA, 2012). More research is needed to address this adoption inertia. The aim of this study is to examine how the characteristics of the mobile marketing affect the adoption of the technology by South African SMEs. The findings of the study will provide important levers to guide mobile marketing developers, marketers, and others interested in promoting a more enthusiastic adoption of this source technology among SMEs in South African, and those others operating in similar contexts.

LITERATURE REVIEW AND RESEARCH HYPOTHESES

Researchers have relied on the innovation diffusion theory to understand the adoption and implementation of technology. A major focus in this approach is on how potential or current users' perception or experience of the innovation influences their decision to begin or continue using the technology. The innovation diffusion theory (IDT) of Rogers (1983) identified five key characteristics of an innovation that influence its rate of diffusion. The literature on firm-level innovation adoption has identified the decision-makers' attitude towards a given technology as a key consideration in its adoption (Damanpour & Schneider, 2009; Moore & Benbasat, 1996). The characteristics of the innovation are often cast as the key antecedents of a potential adopter's attitude towards the adoption and implementation of the innovation (Boyne, Gould-Williams, Law & Walker, 2005; Damanpour & Schneider, 2009; Julnes & Holzer, 2001). Among the five characteristics of innovation that foster its rate of diffusion, researchers (Moore & Benbasat, 1996; Taylor & Todd, 1995; Tornatzky & Klein, 1982) have consistently identified relative advantage, compatibility, and complexity as the major characteristics that influence innovative behaviours.

Consequently, this study examined the potential impacts of relative advantage, compatibility, and complexity on decision-makers' attitude towards the adoption of mobile marketing among manufacturing SMEs in South Africa.

Relative advantage: Relative advantage denotes the extent to which an innovation is perceived to provide benefits that outweigh those of previous innovations (Rogers, 1983). Innovations that are associated with higher relative advantage diffuse faster than those that are not (Taylor & Todd, 1995). Previous studies (Arvidsson, 2014; Sohail & Al-Jabri, 2014) have found that the relative advantage of an innovation plays an important role in influencing the adopters' attitude towards its adoption. Hence it is expected that the relative advantages of the mobile marketing innovation will have a positive effect on decision-makers' attitude towards its adoption. Therefore, this study proposes that:

H1: Relative advantage will have a significant positive effect on SME decision-makers' attitude towards mobile marketing adoption.

Compatibility: Compatibility describes the extent to which an innovation is consistent with the potential adopter's existing values, previous experience, and current needs (Rogers, 1983). Research (Graham & Moore, 2016; Rogers, 1995) shows that innovation that supports the existing values and modes of operation within a firm are more likely to be adopted. Furthermore, prior research (Hung, Chang & Kuo, 2013; Putzer, 2012) highlights that potential users are likely to develop a positive attitude towards adopting a technology that is compatible with their values, culture, previous experience, and needs. For this reason, it is hypothesised that:

H2: Compatibility will have a significant positive effect on SME decision-makers' attitude towards mobile marketing adoption.

Complexity: Complexity refers to the degree to which an innovation is perceived as being difficult to use (Rogers, 1983). Innovations that are perceived to require a lot of physical and mental effort to use are unlikely to diffuse faster within a given social system (Rogers, 1983). Indeed, empirical evidence has identified complexity as a significant barrier to innovation adoption (Mndzebele, 2013). Similarly, prior studies have associated a negative users' attitude towards innovations with those that are perceived as complex (Kennedy & Kennedy, 1996; Vishwanath & Goldhaber, 2003). Consequently, it is expected that:

H3: Complexity will have a significant negative effect on SMEs decision-makers' attitude towards mobile marketing adoption.

METHODOLOGY

Measures

The items used to measure the constructs employed in this study were sourced from prior related studies and adapted to suit the mobile marketing context. The four (4) items used to measure attitude towards adoption were adapted from the study of Yang (2012). The four items used to measure compatibility were selected and adapted from Ghobakhloo, Arias-Aranda and Benitez-Amado (2011) and Lian, Yen and Wang (2014). Complexity was measured with four items sourced from the studies of Oliveira, Thomas and Espadanal (2014) and Ifinedo (2011). Finally, the four items used to measure relative advantage were selected from the studies of Ghobakhloo *et al.* (2011) and Ifinedo (2011). All the items were measured on a seven-point Likert type scale with anchors ranging with 1 'strongly disagree' to 7 'strongly agree'. The questionnaire was pre-tested on a convenient sample of 10 respondents sampled from the population who were asked to comment on the wording of the questions and the clarity of the instructions. Respondents generally stated that the questionnaire was clear and easy to complete. Given this positive feedback, all questions were retained in the final questionnaire.

Sampling and Data Collection

The population of this study was managers/owners of SMEs in the manufacturing sector in the Gauteng Province of South Africa. The sampling lists identified for this study were the Gauteng Small Business Directory and the telephone directory. These lists were compared in order to identify and remove duplications.

A stratified sampling was first used to classify the SMEs into small and medium-sized enterprises, based on the South African definition of small and medium-sized enterprises by the number of employees: fewer than 50, and fewer than 200 full-time employees for small and medium-sized enterprises respectively. This process yielded two strata of 125 small and 95 medium-sized enterprises. After this process, a simple random sampling was used to select participants from each stratum. To select the participants in the small business stratum, random numbers between 1 and 125 were assigned to the elements. The elements were arranged in consecutive order, and the first 95 elements were selected for participation. This sampling process was repeated for the medium-sized enterprises stratum, yielding 80 elements. This effectively yielded a total of 175 possible respondents. Trained assistants approached owners/managers of the selected SMEs with paper-based questions. After explaining the purpose of the study and the ethical measures put in place, their consent was sought to participate in the study. Willing participants had the choice of completing the questionnaire themselves or having the questions read out to them by the research assistants who then recorded their responses on the questionnaire. Of the 175 SMEs enlisted to participate in the study, 156 participated, representing an effective response rate of 89 per cent.

DATA ANALYSIS AND RESULTS

To analyse the measurement and structural model proposed for the study, a structural equation modelling using SmartPLS 3.2.6 was used. Following the two-step process recommended by Anderson and Gerbing (1988), the measurement model was analysed to determine its convergent and discriminant validities. After this, the structural model was analysed to ascertain the structural paths and the predictive power of the model.

To determine the convergent validity of the measurement model, the standardised factors, loadings, Cronbach alpha, composite reliability, and average factor loadings (AVE) were assessed. According to Hair *et al.* (2010), the Cronbach alpha and composite reliability should exceed 0.7, as should the factor loadings and AVEs. According to the results presented in Table 1, the Cronbach alphas ranged between 0.961 and 0.994, and the composite reliability ranged between 0.972 and 0.996, thus exceeding the 0.7 recommended thresholds.

Furthermore, the factor loadings ranged between 0.920 and 0.988 and the AVEs ranged from 0.895 to 0.983 – both higher than acceptable cut-off point of 0.5. These results generally suggest a good convergent validity.

Table 1: Convergent Validity of the Measurement Model

		Factor loading	Cronbach alpha	Composite reliability
Attitude towards adoption	D_AA1	0.991	0.994	0.996
	D_AA2	0.993		
	D_AA3	0.988		
	D_AA4	0.995		
Compatibility	D_CO1	0.972	0.979	0.984
	D_CO2	0.982		
	D_CO3	0.989		
	D_CO4	0.934		
Complexity	D_CX1	0.932	0.961	0.972
	D_CX2	0.960		
	D_CX3	0.973		
	D_CX4	0.920		
Relative advantage	D_RA1	0.979	0.986	0.989
	D_RA2	0.966		
	D_RA3	0.988		
	D_RA4	0.985		

To ascertain discriminant validity, the approach of Fornell and Larcker (1981) was adopted. Table 1 provides the inter-construct correlations and the square root of the AVEs. To achieve discriminant validity, the square of the AVEs should be higher than the inter-construct correlations between the latent constructs. Table 2 provides the inter-construct correlations and the square root of the AVEs. According to the results, the square root of the AVEs (diagonal elements) are greater than any of the inter-factor correlations, thus confirming the discriminant validity of the measurement model.

Table 2: Discriminant Validity of the Measurement Model

	Ave	1	2	3	4
1 Attitude towards adoption	0.983	0.992			
2 Compatibility	0.940	0.744	0.970		
3 Complexity	0.895	-0.461	-0.458	0.946	
4 Relative advantage	0.959	0.728	0.649	-0.457	0.979

After confirming both convergent and discriminant validities for the measurement model, the structural model was assessed to determine the significance of the structural paths and the variance explained in the outcome variable. The significance levels of the paths were analysed using bootstrapping (500 sub-samples). The results of the standardised path estimates and the T-Statistic are summarised in Figure 1 and Table 3.

Figure 1: Measurement and Structural Model

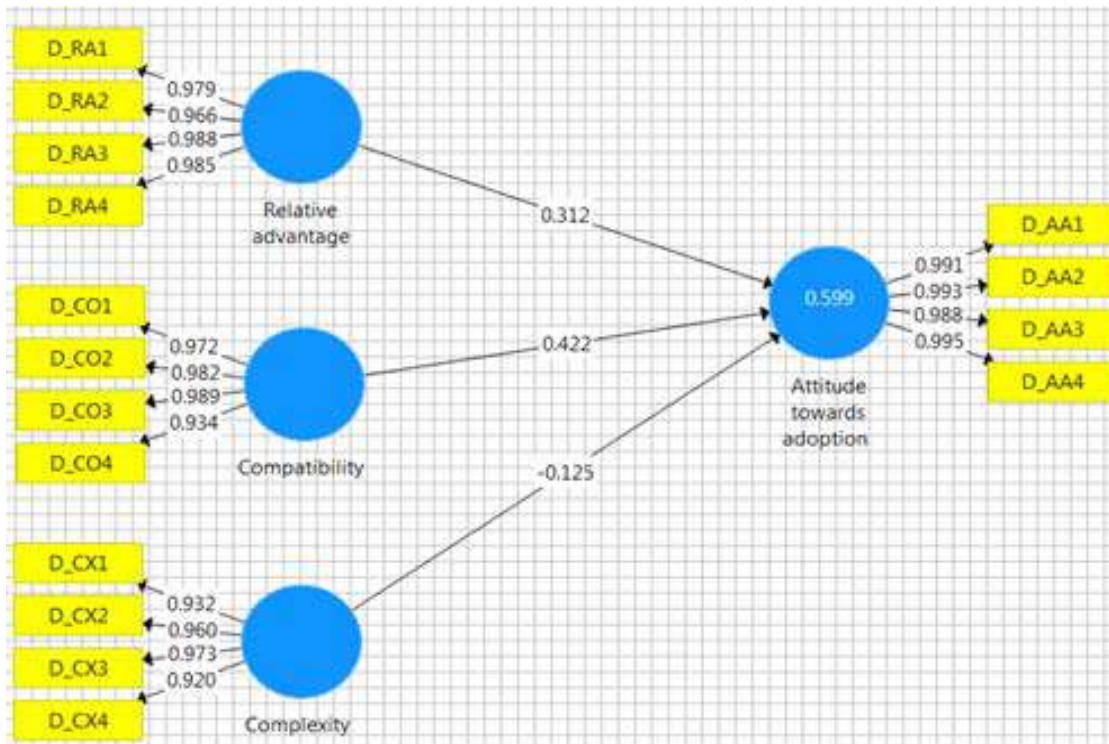

Table 3: Path Analysis for Structural Model

Path	Path co-efficient	T-Statistic
H1 Relative advantage → attitude towards adoption	0.312	2.122**
H2 Compatibility → attitude towards adoption	0.422	2.727*
H3 Complexity → attitude towards adoption	-0.125	1.944***
Attitude towards adoption	$R^2 = 59.9\%$	

*Significant at $p < 0.01$; ** Significant at $p < 0.05$; *** Significant at $p < 0.10$

The results of the analysis indicate that relative advantage has a direct significant positive impact on attitude towards mobile banking adoption by SMEs ($\beta = 0.312$, $t = 2.122$), thus providing support for H1. In respect of the relationship between compatibility and attitude towards mobile marketing, the results of the analysis show that compatibility has a significant positive effect ($\beta = 0.422$, $t = 2.727$) on attitude towards mobile marketing acceptance; hence H2 is supported. Furthermore, the results confirm that complexity is significant and negatively associated with SME decision-makers' attitude towards mobile marketing, thus providing support for H3. These significant factors together explain 59.9 per cent of the variance in SMEs' attitude towards the adoption of mobile marketing.

DISCUSSION AND IMPLICATIONS

The overriding aim of the study is to determine the effects of mobile marketing characteristics (relative advantage, compatibility, and complexity) on SME decision-makers' attitude towards its adoption. The results show that relative advantage and compatibility are significant and positively associated with SMEs' attitude towards mobile marketing adoption. The results further show that complexity is significantly and negatively related to mobile marketing adoption. From these results, a number of conclusions can be drawn and recommendation can be proffered to promote the rapid adoption of mobile marketing among South African SMEs.

The study's finding that relative advantage is a significant direct determinant of mobile marketing adoption is consistent with previous related research (Arvidsson, 2014; Sohail & Al-Jabri, 2014). This means that the perceived benefits associated with mobile marketing technology are crucial determinants in forming decision-makers' attitude towards mobile marketing adoption. Therefore, in order to promote the adoption of mobile marketing among current non-adopters and to increase the frequency of use among current adopters, mobile marketing developers must include key functionalities that are designed particularly to help SMEs overcome their marketing challenges. These functionalities must then form the core of the value proposition of mobile technology, that must be stressed and communicated to the target SMEs in clear and simple language.

The findings of this study also suggest that compatibility is a significant and direct determinant of attitude towards mobile marketing adoption. This finding re-affirms the findings of many previous studies (Hung, Chang & Kuo, 2013; Putzer, 2012) that have consistently identified compatibility as key to the attitude towards technology innovation acceptance. Therefore, to facilitate the adoption of mobile marketing among SMEs, developers must ensure that that technology is consistent with enterprises' existing marketing practices and with their beliefs, values, and past experiences. The better that mobile marketing technology exhibits characteristics that conform to the business practices of the SMEs, the higher the likelihood of its adoption.

The impact of complexity on mobile marketing acceptance among SMEs is found to be significantly and negatively related to the decision-makers' attitude towards the technology's adoption. This result confirms the findings of related existing literature (Kennedy & Kennedy, 1996; Vishwanath & Goldhaber, 2003) that has found complexity to be negatively associated with mobile marketing adoption. Given that the adoption of IT innovation is often associated with complexity (García-Murillo, 2004), it is crucial that mobile marketing developers make the technology user-friendly – that is, free of excessive mental and physical effort – if it is to be adopted. It is also important that developers gauge the technology literacy of their target SMEs in order to make its adoption and implementation less difficult for them.

Although the findings of this study raise a number of important managerial implications for promoting the well-disposed adoption of mobile marketing among SMEs in South Africa, the study has a number of potential limitations to the generalisability of its findings. First, the study's respondents consisted only of the SMEs's decision-makers. This group of people might not be the eventual users of the technology; so their assessment of the characteristics of mobile marketing technology might not be a true reflection of the reality. It therefore recommended that future studies include the views of the end-users of the technology in order to obtain a holistic understanding the phenomenon. Second, the study took place among manufacturing SMEs in the Gauteng Province of South Africa. Although this province is widely regarded as the economic hub of the country, it is largely urban. The views of SMEs operating in South Africa's rural contexts might differ. Consequently, the results of this study might not be applicable to those SMEs. It is therefore important that future studies extend the sample to include SMEs operating in rural areas in order to improve upon the generalisability of the findings to a wider population. Third, Rogers (1995) identified five characteristics of innovations that influence the rate of its adoption. This study only analysed three of these characteristics: relative advantage, compatibility, and complexity. Future studies could consider including the two remaining characteristics, trialability and observability, in order to have a wider understanding of SMEs' perception/assessment of mobile marketing innovation characteristics.

REFERENCES

- Anderson, J. C. & Gerbing, D. W. (1988). Structural Equation Modeling in Practice: A Review and Recommended Two-Step Approach. *Psychological Bulletin*, 103 (3), 411-423.
- Arvidsson, N. (2014). Consumer Attitudes on Mobile Payment Services – Results from a Proof of Concept Test. *International Journal of Bank Marketing*, 32 (2), 150-170.
- Boyne, G. A., Gould-Williams, J. S., Law, J., & Walker, R. M. (2005). Explaining the Adoption of Innovation: An Empirical Analysis of Public Management Reform. *Environment and Planning C: Government and Policy*, 23 (3), 419-435.
- Chen, K. Y., Hsu, Y. L., & Wu, C. C. (2012). Mobile Phone Applications as Innovative Marketing Tools for Hotels. *International Journal of Organizational Innovation*, 5 (2), 116-140.
- Damanpour, F., & Schneider, M. (2009). Characteristics of Innovation and Innovation Adoption in Public Organizations: Assessing the Role of Managers. *Journal of Public Administration Research and Theory*, 19 (3), 495-522.
- Fornell, C., & Larcker, D. F. (1981). Evaluating Structural Equation Models with Unobservable Variables and Measurement Error. *Journal of Marketing Research*, 18 (1), 39-50.
- García-Murillo, M. (2004). Institutions and the Adoption of Electronic Commerce in Mexico. *Electronic Commerce Research*, 4 (3): 201-219.
- Ghobakhloo, M., Arias-Aranda, D., & Benitez-Amado, J. (2011). Adoption of e-commerce applications in SMEs. *Industrial Management & Data Systems*, 111(8), 1238-1269.
- Graham, K. W. & Moore, R. S. (2016). The Influence of Absorptive Capacity and Micro-politics on Firm-Level Technology Adoption Decisions. *2016 SMA Proceedings*, 434.
- Hung, S. Y., Chang, C. M., & Kuo, S. R. (2013). User Acceptance of Mobile E-Government Services: An Empirical Study. *Government Information Quarterly*, 30 (1): 33-44.
- Ifinedo, P. (2011). Internet/e-business technologies acceptance in Canada's SMEs: An exploratory investigation. *Internet Research*, 21(3), 255–281.
- Lian, J. W., Yen, D. C., & Wang, Y. T. (2014). An exploratory study to understand the critical factors affecting the decision to adopt cloud computing in Taiwan hospital. *International Journal of Information Management*, 34(1), 28–36.
- Johnson, P.A. & Plummer, J. (2013). *Mobile marketing economic impact study*. Retrieved 05 May, 2015, from <http://www.mmaglobal.com/documents/mobile-economic-impact-study>.
- Julnes, P. D. L. & Holzer, M. (2001). Promoting the Utilization of Performance Measures in Public Organizations: An Empirical Study of Factors Affecting Adoption and Implementation. *Public Administration Review*, 61 (6): 693-708.
- Kaplan, A. M. (2012). If You Love Something, Let It Go Mobile: Mobile Marketing and Mobile Social Media 4x4. *Business Horizons*, 55 (2): 129-139.
- Kennedy, C. & Kennedy, J. (1996). Teacher Attitudes and Change Implementation. *System*, 24 (3): 351-360.

Lamarre, A., Galarneau, S., & Boeck, H. (2012). Mobile Marketing and Consumer Behavior:

Current Research Trends. *International Journal of Latest Trends in Computing*, 3 (1): 1-9.

MMA. (2012). MSX: Mobile's X% Solution – A Marketing Evolution Whitepaper. Retrieved 05 April, 2017, from http://www.mmaglobal.com/files/mmaglobal.com/Mobiles_share_of_the_mix_Marketing_Evolution_08012012_FINAL.pdf.

Moore, G. C. & Benbasat, I. (1996). Integrating Diffusion of Innovations and Theory of Reasoned Action Models to Predict Utilization of Information Technology by End-Users. In *Diffusion and Adoption of Information Technology*, US: Springer: 132-146

Mndzebele, N. (2013). The Effect of Relative Advantage, Compatibility and Complexity in the Adoption of EC in the Hotel Industry. *International Journal of Computer and Communication Engineering*, 2 (4): 473-476.

Oliveira, T., Thomas, M., & Espadanal, M. (2014). Assessing the determinants of cloud computing adoption: An analysis of the manufacturing and services sectors. *Information & Management*, 51(5), 497-510.

Putzer, G. J. (2012). Are Physicians Likely to Adopt Emerging Mobile Technologies? Attitudes and Innovation Factors Affecting Smartphone Use in the Southeastern United States. *Perspectives in Health Information Management*, Spring 2012, 1-22.

Rogers, E. M. (1983). *Diffusion of Innovations*, 3rd Ed. New York: The Free Press.

Rogers, E. M. (1995). *Diffusion of Innovations*, 4th Ed. New York: The Free Press.

Shankar, V., & Balasubramanian, S. (2009). Mobile marketing: A synthesis and prognosis. *Journal of Interactive Marketing*, 23(2), 118-129.

Sohail, M. S. & Al-Jabri, I. M. (2014). Attitudes Towards Mobile Banking: Are There Any Differences Between Users and Non-Users? *Behaviour & Information Technology*, 33 (4): 335-344.

Taylor, S. & Todd, P. A. (1995). Understanding Information Technology Usage: A Test of Competing Models. *Information Systems Research*, 6 (2): 144-176.

Tornatzky, L. G. & Klein, K. J. (1982) Innovation Characteristics and Innovation Adoption Implementation: A Meta-Analysis of Findings. *IEEE Transactions on Engineering Management*, 29: 28-45.

Vishwanath, A. & Goldhaber, G. M. (2003). An Examination of the Factors Contributing to Adoption Decisions Among Late-Diffused Technology Products. *New Media & Society*, 5 (4): 547-572.

Yang, K. (2012). Consumer Technology Traits in Determining Mobile Shopping Adoption: An Application of the Extended Theory of Planned Behavior. *Journal of Retailing and Consumer Services*, 19 (5): 484-491.

Yan, S. & Chew, D. A. S. (2011). An Investigation of Marketing Strategy, Business Environment and Performance of Construction SMEs in China. *African Journal of Business Management*, 5 (6): 2396-2405.

GREEN SUPPLY CHAIN MANAGEMENT AND SUPPLY CHAIN PERFORMANCE IN MANUFACTURING SMALL AND MEDIUM ENTERPRISES

Chengedzai Mafini and Welby Vandrys Loury-Okoumba
Vaal University of Technology, South Africa

ABSTRACT

The adoption of green supply chain management practices as a strategic initiative remains unfamiliar to many small to medium enterprises (SMEs) in emerging markets such as South Africa. The matter is exacerbated by the dearth of research on green supply chain management in the same contexts. This paper tests a conceptual framework for green supply chain management, operational performance and supply chain performance in manufacturing SMEs in South Africa. Data were collected from 219 SMEs operating within the Gauteng Province. Hypotheses were tested using structural equation modelling. Three green supply chain management practices, namely, green purchasing, reverse logistics, and environmental collaboration with suppliers exerted a positive effect on operational performance. Environmental collaboration with suppliers exerted the highest effect on operational performance when compared to both green purchasing and reverse logistics. In turn, operational performance exerted a strong positive effect on supply chain performance. The results of the study suggest that manufacturing SMEs in emerging markets could benefit by adopting green supply chain management practices, and these benefits can be realised in terms of increases in both operational and supply chain performance.

Keywords: green supply chain management; green purchasing; reverse logistics; environmental collaboration; operational performance; supply chain performance.

INTRODUCTION

Small and medium enterprises (SMEs) are widely recognised as an important contributor to economic development in most countries throughout the world. The economic impact is most noticeable in areas such as employment creation and wealth creation (Baumann-Pauly, Wickert, Spence & Scherer, 2013). In the context of South Africa, SMEs have been acknowledged to account to roughly 52 to 57 percent to South Africa's Gross Domestic Product (GDP) and poured in an estimated 61 percent of employment generation in the past few years (SME South Africa, 2017). However, pressure has mounted on SMEs to reengineer their business practices and processes in line with global developments (Kraus, Coen Rigteling, Hughes & Hosman, 2012). This pressure stems from the high mortality rate of most SMEs, part of which is attributable to their fixedness with outdated business models. As mentioned by Vivier (2013), SMEs cannot afford to continue moving along conventional business trajectories, but need to innovate and realign their strategies in line with global currents. This is experienced more in South Africa, where the SME mortality rate is very high, with most business start-ups experiencing atrophy in less than five years of existence (Cant, Erdis & Sephapo, 2014).

The purpose of this study is to investigate the relationship between GSCM practices, operational performance and supply chain performance in manufacturing SMEs in South Africa. Despite the large body of literature on GSCM, it appears that most of previous studies have had a specific emphasis on large corporations while disregarding SMEs (Campbell 2007; Luthra, Garg, Kumar & Haleem, 2012). In emerging markets such as South Africa, evidence of previous studies of GSCM is limited, with the exception of studies by Ojo, Mbowa and Akinlabi (2014) and Mafini and Muposhi (2017). This is surprising, given that in emerging markets such as South

Africa, SMEs are the most prominent businesses and have a greater economic impact than large businesses. Moreover, the conceptual framework that is put forward in this study is yet to be tested in the context of manufacturing SMEs in South Africa. This study is intended to address these research gaps. The study is significant in that it can be used as a reference source for supply chain management research in SMEs in the future. Owners and managers within SMEs can also use the results of it as a diagnostic tool when addressing operational and supply chain performance related challenges.

LITERATURE REVIEW

Green Supply Chain Management Practices

Over the past years, organisations have become aware of the strategic importance and critical nature and role that the environment play in today's competitive market (Lai, Wong & Cheng, 2010). This has subsequently driven manufacturing businesses to revise their corporate business strategies as well as core supply chain practices towards a greener environmental approach (Sarkis, Zhu & Lai, 2011). As such, GSCM is viewed as an extension of supply chain activities that focus on minimising environmental impact of products throughout their life cycle, such as green design, resource saving, harmful material reduction and product recycle or reuse (Beamon, 1999). The core objective of GSCM is to eliminate or minimise harmful effects originating from operational activities such as extraction/acquisition of raw materials, up to the use or disposal of products (Eltayeb, Zailani & Ramayah, 2011). According to Daibat and Govindan (2011), GSCM embodies a large number of activities such as green design, green sourcing/procurement, green operation/manufacturing, green distribution, and green logistics as well as marketing. A study by Lee, Kim and Choi (2012) identified green purchasing, eco-design and cooperation with customer as GSCM practices. Environment management, reverse logistics, environmental collaboration with suppliers and product recovery are among other practices singled out in a study by Diabat, Khodaverdi and Olfat (2013). However, this study places the spotlight on three GSCM activities, namely, green purchasing, reverse logistics and environmental collaboration with suppliers, which are relevant to the context of manufacturing SMEs (Eltayeb *et al.*, 2011).

Green Purchasing

Green purchasing has been defined by Eltayeb, Zailani and Jayaraman (2009) as an environmentally oriented purchasing activity based on the purchase of products or materials that meet the concern of the environment in terms of reduction of wastage, promotion of recycling, reuse, resource reduction, and substitution of materials. Supply chain management literature identifies several drivers of green purchasing. These include environmental collaboration, top-management commitment, regulatory pressure, environmental investment and customer pressure (Yen & Yen, 2011). Social influence, environmental concerns, perceived seriousness of environmental problems, perceived effectiveness of environmental behaviour, perceived environmental responsibility and concern for self-image in environmental protection have also been identified as key antecedent factors to green purchasing (Sinnappan & Rahman, 2011). Other drivers of green purchasing include awareness about government actions and support, beliefs about product safety and use, beliefs about product friendliness to the environment and availability of product and product information (Kaufmann, Panni & Orphanidou, 2012).

Environmental Collaboration with Suppliers

Environmental collaboration with suppliers can be defined as any form of formal or informal collaborative activity taking place between two or more parties with the objective of engaging in mutual exchanges to solve environmental problems (Crane 1998). Green, Zelbst, Bhadauria and Meacham (2012) in their study on environmental collaboration and organisational performance established that supplier decisions that embark on environmental collaborations is based on factors such as a firm's internal environment management and green information systems. In addition, Zhu *et al.* (2010) advocate that sound collaboration initiatives amongst organisations ensures internal GSCM practices, which are vital in achieving better environmental performance. This singles out the core value attached to proper strategic alliance between business partners. In their study on environmental collaboration and

firm performance, Green, Zelbst, Bhaduria, and Meacham (2012) established that internal environmental management and green information systems are determinant factors of environmental collaboration with suppliers. These authors further suggest that effective and sound collaborative environmental practices with supplying organisations result in improved supplier selection. This indicates then that organisations that are concerned about the environment ensure that their interactions with business partners reflect their concerns.

Reverse Logistics

According to Diabat (2013), reverse logistics refers to the movement of products from the point of consumption to the organisation’s manufacturing sites. Reverse logistics has the objective of recycling, reusing, repairing/remanufacturing and careful disposal of products as well as materials (Das & Chowdhury, 2012). It is acknowledged that reverse logistics is a key contributor to ensuring customer after-sale satisfaction since its core benefits are related to better optimisation of aftermarket processes such as recycling and proper waste disposal (Bernon, Rossi & Cullen, 2011). Khor, Udin, Ramayah and Hazen (2016) advance that the repair, remanufacturing and reconditioning of products and materials are precondition determinants of effective implementation of reverse logistics activities. Furthermore, the critical value resulting from executing reverse logistics has been well documented. Examples of such benefits include an increased business environmental image, cost reduction as well as sustainable customer satisfaction and aftersales services (Wong, Lai, Shang, Lu & Leung, 2012).

Supply Chain Performance

Supply chain performance can be defined as the overall evaluation of an entire firm’s supply chain activities in terms of its effectiveness and efficiency (Gunasekaran, Lai & Cheng, 2008). Supply chain performance includes tangible products and materials as well as intangible aspects such as services and relationships (Eng, 2004). A supply chain operating at an adequate level of its performance objectives is highlighted by performance outcomes such as sustainable cooperation amongst networks partners, which is characterised by seamless information sharing (Banomyong & Supant, 2011). One of the key indicators of a performing supply chain is its effective integration and flexibility of different supply chain units (Qrunfleh & Tarafda, 2014). As such, a proper integrated supply chain results in more improved information conveyed across the whole chain. This subsequently contributes to an increase of firm performance through a reduction of inventory and delivery lead time (Qrunfleh & Tarafdar, 2014). Furthermore, Chang, Tsai and Hsu (2013) advance that partner relationships, information sharing and integration are important determinants of supply chain performance. This gives prominence to the strategic significance of supply chain performance in contributing to the success of an organisation.

CONCEPTUAL FRAMEWORK

The conceptual framework presented in Figure 1 highlights the relationships under investigation. The framework consists of predictor constructs, which are green purchasing, reverse logistics and environmental collaboration with suppliers. Operational performance is the mediating construct and the outcome construct is supply chain performance.

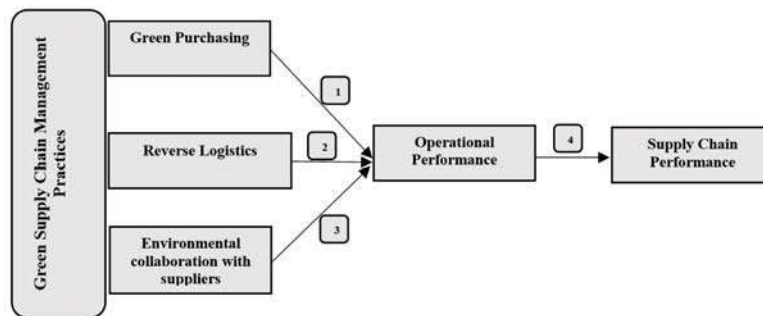

Figure 1: Conceptual Framework Linking Green Supply Chain Management Practices to Operational Performance and Supply Chain Performance

Summary of Hypotheses

The study developed and tested the following hypotheses

H1: Green purchasing exerts a positive and significant influence on operational performance in manufacturing SMEs

H2: Reverse logistics has a positive and significant influence on operational performance in manufacturing SMEs

H3: Environmental collaboration with suppliers has a positive and significant influence on operational performance in manufacturing SMEs

H4: Operational performance has a positive influence on supply chain performance in manufacturing SMEs

RESEARCH METHODOLOGY AND DATA COLLECTION METHOD

Instrumentation, Sample and Data Collection

The study is quantitative in nature, making use of a structured survey questionnaire to collect data from the respondents. Measurement scales were operationalised from previous studies. Green purchasing was measured using six items adapted from a study by Zhu, Sarkis and Lai (2008). Reverse logistics was measured using six questions adapted from Ye, Zhao, Prahinski and Li (2013) while environmental collaboration with suppliers was measured using five questions adapted from Vachon and Klassen (2006). Operational performance was measured using six questions adapted from Zhu *et al.* (2008), and supply chain performance was measured using a ten item-scale adapted from Li, Rao, Li, Ragu-Nathan and Ragu-Nathan (2005) and Ragu-Nathan, Ragu-Nathan and Rao (2006). Response options for the green purchasing and reverse logistics scales were measured on a five point Likert-type scale ranging from (1) not considering it to (5) implementing successfully. However, response options for environmental collaboration with suppliers, operational performance and supply chain performance scales used a different Likert-type scale, which was anchored by (1) not at all and (5) significant.

The target population of the study was composed of manufacturing SMEs across all industries in Gauteng province, South Africa. The list of operating SMEs was obtained from the Gauteng Enterprise Propeller (GEP) and SME databases from the municipalities in the region. The actual respondents comprised 219 owners and managers of these SMEs. To ensure that SMEs from the various regions of the province were represented in the sample, stratified random sampling technique was used. Data were collected between January and May 2016, with the aid of two trained research assistants who were postgraduate students at a university of technology. In administering the questionnaire, various ethical considerations that include the respondents' right to confidentiality and anonymity, privacy or non-participation, informed consent, protection from harm and victimisation were followed. Respondents were not given any incentives for participating in the survey.

RESEARCH RESULTS

Psychometric Properties of Measurement Scales

Data analysis was conducted using a combination of Statistical packages for the Social Sciences (SPSS version 23.0) and the Analysis of Moment Structures (AMOS version 23.0) statistical software. The analysis of psychometric properties of the measurement scales analysis was conducted to ascertain the reliability and validity of the constructs. Factor loadings, Cronbach Alpha (α) and the validity of the constructs average variance extracted (AVE). All five constructs under consideration in this study were reliable, since Cronbach Alpha values were greater than the minimum threshold of 0.7 suggested by Nunnally (1978). Convergent validity was satisfactory, since factor loadings for all items within the measurement scales surpassed the 0.5 minimum threshold suggested by Hair *et al.* (2006). Discriminant validity was also satisfactory since AVE values for the five constructs exceeded the minimum threshold of 0.4 suggested by Anderson and Gerbing (1988). Furthermore, face validity was ascertained through a review of the questionnaire by faculty members who are experts in supply chain management. Content validity was ascertained by pre-testing the questionnaire using a conveniently selected sample of 30 SMEs. Feedback obtained

from the faculty experts and the pretest sample was used to modify the questionnaire to remove any inconsistencies and make it clearer. Therefore, all measurement scales used in the study were both valid and reliable.

Testing the Hypotheses

Hypotheses were tested using the Structural Equation Modelling (SEM) technique. However, before the procedure was applied, it was necessary to test the fitness of the research model, as recommended by Bollen (1990). The results of the model fit analysis were in line with the recommended parameters. Therefore, the data could fit the proposed research model, making SEM feasible. Table 1, presents results of the hypotheses tests.

Table 1: Hypotheses tests results

Proposed Relationships	Hypothesis	Beta Coefficient	Decision
Green purchasing → Operational performance	H₁	0.654***	Accepted
Reverse logistics → Operational performance	H₂	0.612***	Accepted
Environmental collaboration with suppliers → Operational performance	H₃	0.781***	Accepted
Operational performance → supply chain performance	H₄	0.762***	Accepted
Significance level <0.05*; significance level <0.01;*** significance level <0.001**			

An analysis of the results of the hypotheses tests (Table 1) indicates that the beta coefficients for all the hypotheses were statistically significant at a level of $p < 0.01$. Thus, all four hypotheses put forward in this study were accepted.\

DISCUSSION

The first hypothesis (H₁) proposed that green purchasing exerts a positive influence on operational performance. This hypothesis was accepted, because there was a strong positive and significant relationship ($r = 0.654$; $p < 0.01$) between green purchasing and operational performance. This result implies that implementation of green purchasing by manufacturing SMEs predicts their operational performance. This result is supported by a previous study by Rao and Holt (2005), which established that green purchasing initiatives contribute to waste and hazardous product reduction. This results in improved adherence to environmental regulations in terms of efficient operations and production processes. Dubey, Bag, Ali and Venkatesh (2013) add that implementation of green purchasing promotes the adoption of eco-friendly operational strategies, which again correlates with sound and safe operational outcomes. Furthermore, green purchasing has been found to be a key tool designed at improving operational performance through lowering production costs and sustaining the reduction of pollution (Green *et al.*, 2012). In line with these results, manufacturing SMEs will be able to realise similar benefits in their operations when they adopt green purchasing strategies.

The second hypothesis (H₂) proposed a positive association between reverse logistics and operational performance. This relationship was supported and accepted because a strong positive and significant association ($r = 0.612$; $p < 0.01$) was observed between reverse logistics and operational performance. This result demonstrates that implementation of reverse logistics by manufacturing SMEs results in improved operational performance. This result has been echoed by El Korchi and Millet (2011) who found that reverse logistics results in competitive advantages through its role in enhancing operation capabilities. For instance, poor quality raw materials may be identified and returned to the supplier and exchanged with better quality ones, which results in better quality products. Moreover, systems and processes for facilitating tend to promote the effective utilisation of organisational resources in the production phase (Ye, Udin, Ramayah & Hazen, 2016). This is because putting in place an effective chain of product returns enables the operations process to be leaner and facilitates better repair and recondition of defective goods (Yang, Hong & Modi, 2011). This improves the performance of the operations process by enhancing the repurchase value of the returned goods. In this manner, adoption of reverse logistics practices by manufacturing SMEs enhances the operational performance of their value chain.

The third hypothesis (H₃) proposed that there exists a positive and significant association between environmental collaboration with suppliers and operational performance. This hypothesis was accepted, since the relationship between environmental collaboration with suppliers was positive and significant ($r = 0.781$; $p < 0.01$). This result demonstrates that operational performance will improve when manufacturing SMEs collaborate with their suppliers and form long lasting relationships. This result resonates with a study by Yang, Lu, Haider and Marlow (2013), which stressed that collaborative engagement between businesses and suppliers is important in improving operational performance. Zhao, Huo, Flynn and Yeung (2008) reiterates that collaborative efforts between businesses and suppliers aid their combined ability to share environmental risks and problem solving expertise, which is vital in leveraging competitive advantage. Chandra, Grabis and Tumanyan (2007) further add environmental collaboration efforts between firms contribute to achieving operational performance objectives.

Accordingly, environmental collaborative initiatives with suppliers in manufacturing SMEs contribute significantly to the attainment of their operational objectives.

The fourth hypothesis (H₄) proposed that there is a positive and significant relationship between operational performance and supply chain performance. This hypothesis was accepted because a strong positive and significant association ($r = 0.762$; $p < 0.01$) was observed between the two constructs. This result illustrates that higher operational performance by a manufacturing SME leads to superior performance of the supply chain in which that SME operates. The results of this study correlate with a study by Trkman McCormack, De Oliveira and Ladeira (2010), which concluded that proper operational performance ensures that the supply chain of a business is able to meet the demands and expectations of customers. Furthermore, Hoole, Disney, Holmstrom and Smaros (2005) posit that firms that can improve their operation performance are more likely able to minimise their operation costs and to boost the effectiveness of the whole supply chain. Thus, manufacturing SME supply chains are likely to improve significantly, whenever SMEs can sustain their operational performance.

CONCLUSION AND MANAGERIAL IMPLICATIONS

The purpose of this study was to investigate the relationship between GSCM practices, operation performance and supply chain performance in manufacturing SMEs. The study concludes that GSCM practices, namely, green purchasing, reverse logistics and environmental collaboration with suppliers contribute to operational performance in manufacturing SMEs. The study further concludes that operational performance in manufacturing SMEs influences supply chain performance.

The results of this study have theoretical and managerial implications. Theoretically, the results represent a current addition to the body of literature on supply chain management in manufacturing SMEs, particularly in emerging economies such as South Africa. This is important, since the conceptual framework tested in this study has not been tested before in this environment. The study therefore constitutes a reference source for future researchers in supply chain management in similar environments. To managers in manufacturing SMEs, implementation of GSCM practices is key to increase both operational and supply chain performance. Likewise, the inability to adopt GSCM practices in manufacturing SMEs could account for some of the challenges related to both operational and supply chain performance. When applying GSCM practices, more emphasis should be placed on collaborating with suppliers, which exerts a greater impact on operational performance than does green purchasing and reverse logistics.

REFERENCES

- Anderson, J.C., & Gerbing, D.W. (1988). Structural equation modeling in practice: A review and recommended two-step approach. *Psychological Bulletin*, 103(3), 411-423.
- Banomyong, R., & Supatn, N. (2011). Developing a supply chain performance tool for SMEs in Thailand. *Supply Chain Management: an International Journal*, 16(1), 1-31.
- Baumann, P, Wickert, D., Spence, L.J.C., & Scherer, A.G. (2013). Organising corporate social responsibility in small and large firms: size matters. *Journal of Business Ethics*, 115(4), 693-705.
- Beamon, B.M. (1999). Designing the green supply chain. *Logistics Information Management*, 12(4), 332-342.
- Bernon, M., Rossi, S., & Cullen, J. (2011). Retail reverse logistics: a call and grounding framework for research. *International Journal of Physical Distribution & Logistics Management*, 41(5), 484-510.
- Bollen, K.A., (1990). Overall fit in covariance structure models: Two types of sample size effects. *Psychological Bulletin*, 107(2),56-259.
- Campbell, J.L. (2007). Why would corporations behave in socially responsible ways? An institutional theory of corporate social responsibility. *Academy of Management Review*, 32(3), 946-967.
- Cant, M.C., Erdis, C., & Sephapo, C.M. (2014). Business survival: the constraints experienced by South African SMEs in the financial sector. *International Journal of Academic Research in Business and Social Sciences*, 4(10), 565-570.
- Chandra, C., Grabis, J., & Tumanyan, A. (2007). Problem taxonomy: a step towards effective information sharing in supply chain management. *International Journal of Production Research*, 45 (11), 2507-2544.
- Chang, H.H., Tsai, Y.C., & Hsu, T.C.H. (2013). E-procurement and supply chain performance. *Supply Chain Management: An International Journal*, 18(1), 34-51.
- Crane, A. (1998). Exploring green alliances. *Journal of Marketing Management*, 14, 559-579.
- Das, K., & Chowdhury, A.H. (2012). Designing a reverse logistic network for optimal collection, recovery and quality-based product-mix planning. *International Journal of Production Economics*, 135 (1), 209-221.
- Diabat, A., & Govindan, K. (2011). An analysis of the drivers affecting the implementation of green supply chain management. *Resource. Conservation & Recycling*, 55(6), 659-667.
- Dubey, R., Bag, S., Ali, S.S., & Venkatesh, V.G. (2013). Green purchasing is key to superior performance: An empirical study. *International Journal of Procurement Management*, 6(2), 187-210.
- El Korchi, A., & Millet, D. (2011). Designing a sustainable reverse logistics channel: The 18 generic structures framework. *Journal of Cleaner Production*, 19(6-7), 588-597.
- Eltayeb, T. K.; Zailani, S. 2009. Going green through green supply chain initiatives towards environmental sustainability. *Operations and Supply Chain Management*. 2 (2):93-110.
- EITayeb, T.K, Zailani, S., & Jayaraman, K. (2010). The examination on the drivers for green purchasing adoption among EMS 14001 certified companies in Malaysia. *Journal of Manufacturing Technology Management*, 21(2), 206-225.
- Eltayeb, T.K., Zailani, S., & Ramayah, T. (2011). Green supply chain initiatives among certified companies in Malaysia and environmental sustainability: Investigating the outcomes. *Resources, Conservation & Recycling*, 55(5), 495-506.
- Eng, T.Y. (2004). The role of e-marketplaces in supply chain management. *Industrial Marketing Management*, 33(2), 97-105.

- Green, K.W., Zelbst, P.J., Bhadauria, V.S., & Meacham, J. (2012). GSCM practices: impact on performance. *Supply Chain Management: An International Journal*, 17 (3), 290-305.
- Green, K.W., Zelbst, P.J., & Bhadauria, V.S., & Meacham, J. (2012). Do environmental collaboration and monitoring enhance organizational performance? *Industrial Management & Data Systems*, 112(2), 186-205.
- Gunasekaran, A., Lai, K., & Cheng, E. (2008). Responsive supply chain: A competitive strategy in a networked economy. *OMEGA*, 36 (4), 549-564.
- Hair, J.F., Black, W.C., Babin, B.J., Anderson, R.E., & Tatham, R.L. (2006). *Multivariate data analysis*. Auflage, Upper Saddle River.
- Hoole, R. (2005). Five ways to simplify your supply chain. *Supply Chain Management: An International Journal*, 10(1), 3-6.
- Kannan, D., Khodaverdi, R., Olfat, L., Jafarian, A., & Diabat, A. (2013). Integrated fuzzy multi criteria decision making method and multi-objective programming approach for supplier selection and order allocation in a green supply chain. *Journal of Cleaner Production*, 47, 355-367.
- Kaufmann, H.R., Panni, M.F.A.K., & Orphanidou, Y. (2012). Factors affecting consumers' green purchasing behavior: An integrated conceptual framework. *Amfiteatru Economic*, 14(31), 50-69.
- Khor, K.S., Udin, Z.M., Ramayah, T., & Hazen, B.T. (2016). Reverse logistics in Malaysia: The Contingent role of institutional pressure. *International Journal of Production Economics*, 175, 96-108.
- Kraus, S.J.P., Rigtering, C., Hughes, M., & Hosman, V. (2012). Entrepreneurial orientation and the business performance of SMEs: a quantitative study from the Netherlands. *Review of Managerial Science* 6, 2, 161-182.
- Lai, K.H., Wong, C.W., & Cheng, T.C.E., (2010). Bundling digitized logistics activities and its performance implications. *Industrial Marketing Management*, 39(2), 273-286.
- Lee, S.M. Kim, S.T., & Choi, D. (2012). Green supply chain management and organisational performance, *Industrial Management & Data Systems*, 112(8), 1148-1180.
- Li, S., Ragu-Nathan, B., Ragu-Nathan, T.S., & Rao, S.S. (2006). The impact of supply chain management practices on competitive advantage and organisational performance. *OMEGA* 34 (2), 107-124.
- Li, S., Rao, S.S., Ragu-Nathan, T.S., & Ragu-Nathan, B. (2005). Development and validation of a measurement instrument for studying supply chain management practices. *Journal of Operations Management*, 23(6), 618-641.
- Luthra, S., Garg, D., Kumar, S., & Haleem, A. (2012). Implementation of the green supply chain management in manufacturing industry in India using interpretive structural modeling technique. *BPR Technologia: A Journal of Science, Technology & Management*, 1(1), 1-17.
- Mafini, C., & Muposhi, A., (2017). The impact of green supply chain management in small to medium enterprises: Cross-sectional evidence. *Journal of Transport & Supply Chain Management*, (1), 1-11.
- Nunnally, J. (1978). *Psychometric methods*. 2nd ed. New York: McGraw-Hill.
- Ojo, E., Mbowa, C. & Akinlabi, E.T. (2014). Barriers in implementing green supply chain management in construction industry. In *Proceedings of the 2014 International Conference on Industrial Engineering and Operations Management*, 7-9.
- Qrunfleh, S., & Tarafdar, M. (2014). Supply chain information systems strategy: impacts on supply chain performance and firm performance. *International Journal of Production Economics*, 147, 340-350.
- Rao, P. & Holt, D. (2005). Do green supply chains lead to competitiveness and economic performance? *International Journal of Operations & Production Management*, 25(9), 98-916.

- Sarkis, J., Zhu, Q., & Lai, K.H., (2011). An organisational theoretic review of green supply chain management literature. *International Journal of Production Economics*, 130(1), 1-15.
- Sinnappan, P., & Rahman, A.A. (2011). Antecedents of green purchasing behavior among Malaysian consumers. *International Business Management*, 5(3), 129-139.
- SME South Africa (2017). Why SA SMEs can expect better prospects in 2017. <http://www.smesouthafrica.co.za/17024/3-reasons-SA-SMEs-can-expect-a-better-2017/>. 22 May 2017.
- Trkman, P., McCormack, K., De Oliveira, M.P.V., & Ladeira, M.B. (2010). The impact of business analytics on supply chain performance. *Decision Support Systems*, 49(3), 318-327.
- Vachon, S., & Klassen, R.D. (2006). Extending green practices across the supply chain: The impact of upstream and downstream integration. *International Journal of Operations & Production Management*, 26(7), 795-821.
- Vivier, E. (2013). A tough line to work through: Ethical ambiguities in a South African SME. *African Journal of Business Ethics*, 7(2), 68-78.
- Wong, C., Lai, K.H., Shang, K.C., Lu, C.S., & Leung, T. (2012). Green operations and the moderating role of environmental management capability of suppliers on manufacturing firm performance. *International Journal of Production Economics*, 140 (1), 283-294.
- Yang, C.S., Lu, C.S., Haider, J.J., & Marlow, P.B. (2013). The effect of green supply chain management on green performance and firm competitiveness in the context of container shipping in Taiwan. *Transportation Research Part E: Logistics & Transportation Review*, 55, 55-73.
- Yang, M.G.M., Hong, P., & Modi, S.B. (2011). Impact of lean manufacturing and environmental management on business performance: An empirical study of manufacturing firms. *International Journal of Production Economics*, 129(2), 251-261.
- Ye, F., Zhao, X., Prahinski, C., & Li, Y. (2013). The impact of institutional pressures, top managers' posture and reverse logistics on performance: Evidence from China. *International Journal of Production Economics*, 143(1), 132-143.
- Yen, Y., & Yen, S. (2011). Top-management's role in green purchasing standards in high-tech industrial firms. *Journal of Business Research*, 65(7), 951-959.
- Zhao, X., Huo, B., Flynn, B.B., & Yeung, J. (2008). The impact of power and relationship commitment on the integration between manufacturers and customers in a supply chain. *Journal of Operations Management*, 26(3), 368-388.
- Zhu, Q., Sarkis, J., & Lai, K. (2008). Confirmation of a measurement model for GSCM practices implementation. *International Journal of Production Economics*, 111 (2) 261-273.

THE EFFECT OF HUMAN CAPITAL INVESTMENT AND MOTIVATION ON MINERS' PRODUCTIVITY AT A SOUTH AFRICAN PLATINUM MINE

Lucky Boy Tebogo Makhubedu, Eveth Nwobodo-Anyadiegwu and
Charles Mbohwa
University of Johannesburg, South Africa

ABSTRACT

Human capital investment and employee motivation are mechanisms that mining companies can use to enhance labour performance, improve organizational productivity, optimise profitability, and achieve long-term competitive advantage. This paper investigates the effects of human capital investment and motivation on mineworkers' labour productivity at a South African Platinum mine. This study adopted a quantitative research strategy. A structured questionnaire was used to survey (n = 292) miners. SPSS version 23.0 was performed to measure the relationship between miners' perception of subsets of human capital investment and motivation versus identified key production variables from two distinctive reefs – the Upper Ground (UG2) Reef and Merensky reef. The statistical findings corroborated the two hypotheses tested.

Keywords: Human Capital Investment, Motivation, Productivity, Mining, South Africa.

INTRODUCTION

The mining and manufacturing industries have clear parallels in that both sectors focus on productivity. However, this intense focus – and the intense pressure to meet monthly production targets within specific time limits – tends to negate the miners' ability to perform, leading to reduced morale and motivation within the workplace (Masia and Pienaar, 2011, p. 1). The literature (Adekola, 2014; Awan and Sarfraz, 2013; Boroujerdi, Siadat, Hoveida and Khani, 2014; Olayemi, 2012) reveals that an investment in human development and in motivational incentives has a positive impact on labour performance. Despite this, the South African mineral exploration industry is confronted with labour unrests that hamper the industry's capacity to maintain overall productivity and safety standards (Motsoeneng, Shultz & Bezuidenhout, 2013, p. 1).

In 2012 and 2014, sudden and unprotected industrial unrest and a wave of violence disrupted mining production across South Africa. Consequently, the mining sector had a production deficit of over R15 billion in the financial years 2012 to 2013. Furthermore, the downgrading of the country's credit rating was a result of mining personnel (miners) downing tools (South African Institute of Race Relations, 2013). This clearly shows how the mineral exploration industry and the South African labour market are not immune to global economic challenges.

According to Awan and Sarfraz (2013, p. 1), companies ought to nurture and develop the skills of their workforce, increase investment in human capital labour market, provide learning opportunities within the workplace, and redress unfairness in employment prospects. Furthermore, because of the dangers linked with the mineral exploration industry, ensuring that the miners are motivated should be a priority to mine management, as this would reduce labour unrest in the mining industry (Kuranchie-Mensah & Amponsah-Tawiah, 2016).

The human capital approach has to do with a set of human attributes that people own: work experience, skills, knowledge, health, and intangible qualities such as self-confidence, responsibility, and motivation (Shomos, 2010, p. 1). The concept of human capital regards human labour as a product that can be bartered in the acts of buying and selling (Marimuthu, Akokiasamy & Ismail, 2009, p. 267). Employees offer their operational services to organizations for which, in turn they are compensated.

Motivation comes from the word 'motive'. 'Motivation' is a systematic method of invigorating the needs of employees, influencing their behaviour, and persuading them to perform, by creating a workplace that is suitable to work in (Cetin, 2013, p. 71). Motivation is the inner (intrinsic) drive that enables an individual to make decisions, take action, and achieve improved labour performance (Chaudhary & Sharma, 2012, p. 29).

It is essential to acknowledge that the mineral exploration industry is performance-driven because of the type of work (extraction of essential minerals and ore) done by miners. Hence, labour productivity is a significant factor when optimising organizational profitability (Cetin, 2013). This further heightens the importance of human capital investment and employee motivation in improving labour and organizational productivity (Muogbo, 2013). Conventional measures of performance in operational management are productivity and efficiency (Greasley, 2010, p. 511). Productivity can be defined by the value of the output (end-product) divided by the input (human capital and tangible resources) (Heizer & Render, 2006, p. 15). Improved productivity is a result of increasing output without a proportionate increase in human capital and physical resources, or a reduction in human capital and physical resources without a proportionate reduction in output (Greasley, 2010, p. 511).

According to Greasley (2010):

"Efficiency is defined as a measure of the use of capacity remaining after the loss of output due to planned factors such as maintenance and training". (p. 512).

Previous studies (Marimuthu et al, 2009; Awan & Sarfraz, 2013; and Boroujerdi et al., 2014) have generalised the assumption or expectation that human capital investment and motivation impact positively on labour performance. Most research studies indicate that training and motivation affect productivity and not the other way around (Hansson, Johanson & Leitner, 2004). This has consistently been proven by researchers (Raineri, 2016; Kuranchie-Mensah and Amponsah-Tawaiah, 2016); but whether it applies to miners' in South Africa remains to be tested empirically. As a result, failing to account for unobserved or external factors, leads to underestimating the impact of human capital investment and employee motivation on productivity (Colombo & Stanca, 2008). There have been calls made by some scholars for the need to study the simultaneous contributions of both the human capital and motivation to performance relationship (Raineri, 2016, p. 4).

Emerging from the foregoing discussion, the main objective of this study was to empirically investigate the effect of human capital investment and motivation on miners' productivity at a South African platinum mine.

LITERATURE BACKGROUND

An American economist, Theodore Shultz, first coined the term 'human capital' in the 1960s. He hypothesised that investing in physical capital by spending on machinery might have significant parallels or similarities in human capital through spending on education (learning) and training (skills development) (Boroujerdi et al., 2014, p. 1). Schultz (1961:25) was under no illusion that people would find the idea of referring to human beings as 'capital' and using education and training as the medium of investment difficult to accept. Schultz suggested that economists ought to reappraise the notion of 'education' as a constituent of human capital, rather than as a product for consumption.

Schultz (1961) stated that:

"Economists have long known that people are an important part of the wealth of nations. Measured by what labour contributes to output, the productive capacity of human beings is now vastly larger than all other forms of wealth taken together. What economists have not stressed is the simple truth that people invest in themselves and that these investments are very large". (p. 25).

Human Capital (HC)

Human capital is receiving broader attention with increasing globalisation and job market saturation caused by the current decline in many world economies. A strategic plan for enhancing personnel productivity is to work towards driving added value for the company (Marimuthu et al., 2009, p. 1). In business (Awan and Sarfraz,

2013), capital is required in order to keep it afloat (p. 1). Organizational assets, bank accounts, physical resources etc., are referred to as capital, but in the midst of it all, lies human capital. Human capital plays a key role in improving employee productivity (Heizer & Render, 2006, p. 16).

Human capital may be acquired by means of education (learning), training (skills development) and healthcare (health and safety) that will result in enhanced knowledge, skills, capabilities and values, leading to the accomplishment of employee loyalty, satisfaction and high levels of employee productivity, while enhancing overall business, operational performance and attainment of optimal profitability (Marimuthu et al., 2009, p. 267). Boroujerdi et al. (2014, p. 1) concur with the idea of Marimuthu et al. (2009, p. 266) by indicating that human capital deals with the higher value that workers provide for the company to achieve competitive advantage. According to Boroujerdi et al. (2014, p. 2), the dimensions of human capital are required for workers to function and perform at their best. The advantages of training, education, and healthcare are improved labour performance, enhanced organizational productivity, and a possible increment in pay after the completion of the education and training (Dae-Bong, 2009, p. 1).

According to Barr & Cook (2009, p. 19), education is an essential tool for any skills development. The quality of education for black South Africans is regarded by most to be unsatisfactory, unfitting, and inexcusable (Cairns, 2015, p. 2). In every country, education relates to the employability of the population, as it defines the category of human resources and the quality of knowledge and skills that a particular country has. Education refers to acquiring knowledge and skills through educational systems that increase the probability of population employability (Mbwaalala, 2013, p. 8). The education system covers an extensive range of indirect benefits that encourage change in the attitude of people towards their occupation and the community in which they live. Through education and training, it becomes easier for people to develop new skills. Education has a positive influence on how people perform and on how efficient organizations are – and it can fuel the economy. Education also contributes to the number of knowledgeable people, increases their earning capacity, enhances the productivity of the workforce, and reduces unemployment (Olayemi, 2012, p. 299).

The fundamental challenge that the Republic of South Africa's labour market faces is an overwhelming increase in the unskilled labour force. The government of South Africa, aiming to redistribute the wealth of the country more impartially, has pushed for an escalation in the development of skilled labour (Saunders, 2013, p. 2). Saunders (2013, p. 2) reported that unskilled labour accounted for 28.9% of all labour in 2012.

In 1998, through administering the Skills Development Act (SDA), amended in 2003 and 2006, the government of South Africa sought to educate and develop the workers who were unskilled. The Act strives to nurture and develop the skills of the workforce, increase investment in human capital, encourage employers to offer learning opportunities within the workplace, and redress unfairness in employment prospects. The primary aim of the Skills Development Act No. 97 of 1998 (SDA) is to ensure that the South African workforce goes through rigorous training to develop its skills, thereby improving employee productivity and quality, delivering social services within the workplace, and promoting self-employment. The act also permits management to use their workplace as an active learning environment and to provide workplace experience to new workers joining the labour market (Bhoola, 2011).

To produce a unique and valued staff, training and personnel development is crucial within an organization (Nyamubarwa, Mupani & Chiduro, 2013, p. 119). Training and employee development can help individual workers to make better decisions, improve their confidence and problem-solving skills, increase their job satisfaction, and help them better to manage both their own stress and frustration and tension and conflict within the organization (Rusinovci, 2015, p. 106).

Olayemi (2012, p. 299) suggests that healthcare comes after education in the advancement of human development. There is a reciprocal connection between healthcare and education. Education promotes the general development of the different skills required to transform a society and to meet high health levels; education champions transformation in people's attitudes and habits. Olayemi (2012) further proposes that, to make the best use of a nation's labour force and resources, it is vital to have a healthy population, as it is an important part of the development of employees' abilities. A decline in good health will result in low productivity and high health-care costs. The Occupational Health and Safety Act (OHSA), promulgated in 1993 to guarantee the health and safety of people at work, relates to their use of operating equipment and machinery.

Furthermore, the Act ensures the safety of other employees against threats to their health through other workers' activities in the workplace (Bhoola, 2011).

Awan and Sarfraz (2013, p. 1) maintain that human capital can help organizations to grow and reach their maximum potential. Human capital investment goes beyond just developing the workforce to improve labour and operational performance; it makes employees feel that they have some social status, and that they are valued and recognised within the organization (Dubrin, 2009, p. 377). Empowered employees, through human capital, can execute their tasks more effectively and efficiently, be more knowledgeable, enhance product quality, and support the company's innovative developments (Bashir, Ahmed & Hashim, 2012). A knowledgeable, highly-skilled, and healthy workforce is essential to any organization and country. Any mismanagement of human development, any compromise in health and safety, and any mistreatment or abuse of workers is harmful to organizational success. The primary goal of organizations is to improve labour performance and to achieve high levels of productivity, optimise profit, and achieve long-term competitive advantage. Therefore, emerging from the foregoing discussion above, we can hypothesise that:

Factor₁: Human capital investment as a factor of productivity.

H₁: The more mineworkers are knowledgeable, highly-skilled, and healthy within the mining company, the higher the levels of labour and organizational productivity.

The global economic environment is changing rapidly. According to Ravi (2015, p. 22), the nations of the world have begun to embrace free market capitalism, leading to international markets being highly competitive. Responding to present-day economic changes in the international business market, most companies have adopted the notion that investing in employees' abilities leads to achieving a reputable, competitive advantage that will enhance workers' motivation, employee empowerment, job satisfaction, productivity, and economic growth (Olayemi, 2012, p. 300). Investment in human capital has proved to be fruitful in other parts of the African continent. Nigeria, for instance, has recently surpassed South Africa as the continent's largest grossing economy; and in the global economy ranking it comfortably occupies the 26th position. This is because the rebasing of Nigeria's gross domestic product (GDP) skyrocketed the oil-dependent economy from 42.3 trillion Nairas to 80.3 trillion Nairas – equivalent to 509.9 billion US dollars. Establishing this new base level included different industries such as film-making, music, airlines, and telecommunication (Adekola, 2014, p. 214). In 2013, Nigeria's nominal GDP was approximately 510 billion US Dollars – 89% larger than previously estimated, and 190 billion US Dollars more than that of South Africa (Els, 2014, p. 1).

Motivation

Every company, whether public or private, has a set of organizational goals that it wants to achieve. In pursuit of these targets, certain measures have to be in place that make it possible to meet these goals. According to Chaudhary and Sharma (2012, p. 31), employees have different likes, dislikes, and distinctive needs that will motivate each individual differently. It is very important that management engage workers in decision-making processes – but, at the same time, create sensible and practical goals that employees can achieve. According to Bashir et al. (2012, p. 13), improved labour performance and organizational productivity hinges on how well employees are rewarded, and how content and emotionally attached they are (Dubrin, 2009, p. 372). Hence, motivation is also part of an important aspect of management in any organization (Chipunza, Samuel & Mariri, 2011, p. 8340). It is natural that people have specific needs that they attempt to satisfy. Unfortunately, employers hypocritically choose to ignore these needs (Cetin, 2013).

Motivational Approach by South African Mines

Most mines recognise the importance of human capital investment in advancing employees' abilities to enhance high levels of employee performance in the workplace. According to Nyamubarwa et al. (2013, p. 120), the human capital approach, through investment in the dimensions of human capital – education, training, and healthcare – can help miners feel that they are valued, improve employee motivation/morale, and realise the workers' full potential. Mining companies regularly put miners through rigorous training programmes to harness

their skills and talents, thus improving productivity, quality, and the delivery of social services in the workplace, and promoting self-employment (Lebeloane, 2016, p. 3). Furthermore, through the Adult Basic Education and Training (ABET) programme, which is accredited by the Mining Qualification Authority (MQA), miners are encouraged to attend literacy and numeracy courses, thereby improving their educational base – their ability to read and write (Mining Qualification Authority, 2015, p. 3). A drawback is that, miners have a habit of not attending these literacy and numeracy courses.

The issue of remuneration, however, is subject to how organizations use it and other incentive schemes such as performance-based bonuses to inspire and improve mineworkers' job commitment (Manzoor, 2012, p. 38). Monetary schemes are one of many management tools that mining companies use to curb industrial unrest and alleviate poverty. Furthermore, miners are provided with opportunities to be home owners. The benefits of home-ownership are that they can bring their families from other provinces and countries to stay with them. Secondly, they can be closer to their workplace, which makes travelling time to work manageable. They have access to clean water and sanitation, electricity, and proper road infrastructure.

Mining companies comply with the Underground Mining Regulations, made under Section 82 of the Occupational Health and Safety Act, which ensure that mines create and maintain a safe and healthy working environment for all mining personnel (The Underground Mining Regulations made under Section 82 of the Occupational Health and Safety Act, 2008). These basic human needs are aligned with Abraham Maslow's hierarchy of needs theory (1954), the McClelland needs theory (1976), Alderfer's theory of existence, relatedness and growth (ERG) (1973), and Herzberg's motivator-hygiene theory (1959).

There have also been calls by mining personnel for more transparency within the mineral exploration industry. Mines should endorse a transparency plan that would allow miners to have easy access to information within the organization, as this would empower them. In their study, "Effective motivation practices that could enhance employee performance in the mining industry", du Plessis, Keovilay, Marriot and Seth (2015) found that motivational factors – remuneration, safety, social welfare, supervision, and equity – are the five main factors that motivate mining staff in Laos, New Zealand to perform. Masia and Pienaar (2011, p. 1), in their study, "Unravelling safety compliance in the mining industry: Examining the role of work stress, job security, satisfaction and commitment as antecedents", found that promoting job satisfaction could improve safety compliance in an organization, while other factors such as job insecurity and work-related stress impact negatively on safety.

Link between Human Capital Investment and Motivation

Every company, whether public or private, has a set of organizational goals and objectives, that it wants to attain. In pursuit of these targets, there has to be certain measures in place that would make it feasible to achieve these goals and objectives. Most companies recognize the importance of human capital investment in advancement of employees' abilities to induce high levels of employee performance within the workplace.

Human capital dimensions – education, training and healthcare are important if workers are to have the motivation that is required to develop and use their skills and knowledge within the organization. However, education and training are less effective for problems arising from worker's lack of motivation (Yamoah, 2014, p. 4). Yamoah (2014) further argues that well-trained personnel often exhibit high levels of motivation and confidence, attributing it to the organization investing in their ability and development. These well-trained employees tend to be productive and can make discretionary decision-making. An advantage of investment in human development is a possible increment in remuneration, after employees have completed training and education (Dae-Bong, 2009, p. 1). Gross (2015, p. 6) concur with Yamoah (2014) by suggesting that, organizations that invest in human development have high levels of skills, retention and motivation. It is clear that, not only employees' benefit from investment in human capital but also companies benefit as well. Human capital investment and motivation are management concepts that companies use to induce the South African labour markets' abilities through training and development to improve labour and organizational performance (productivity) (Awan & Sarfraz, 2013, p. 81).

Previous studies by (Aarabi, Subramaniam and Abu Baker Akeel, 2013; Chaudhary and Sharma, 2012; Edrak, Ying-Fah, Gharleghi and Seng, 2013; Nyamubarwa et al. 2013); all agree that performance-based

compensation or payment (merit pay) is effective in improving employee performance as workers exert more effort in executing their jobs with the expectations of being rewarded. This is aligned to Vroom's expectancy theory (1964). From a managerial perspective, Vroom's expectancy theory contains significant implications and points out several key factors that can be utilized to motivate employees within the workplace by changing an individual's or groups performance-to-reward (Lunenburg, 2011, p. 1).

Many motivational factors play a significant role in the concept of employee motivation. Based on each particular situation, it is imperative that we establish which motivational tool will be more effective (Kalburgi & Dinesh, 2010, p. 152). It is also important to take note that although some motivational tools will work for one company, it does not necessarily mean that they will work for another. Chaudhary and Sharma (2012, p. 30) further suggests that sometimes management fails to recognise the importance of motivation in achieving their mission and ideology or vision. Even when management understands the importance of motivation, they appear to lack the competence to create a workplace that promotes employee productivity. The following specific motivational tools are relevant in improving employee productivity.

Incentive schemes/rewards are tools such pay, bonuses, performance-based payment (merit pay) and promotion that managers can utilize to influence workers behaviour and encourage higher levels of employee performance within the organization (Manzoor, 2012, p. 36). Employees' performance can improve organizational productivity by changing the resource inputs that are required to achieve their projected production outputs. Nevertheless, besides employee performance, there are numerous motivational factors, that could influence organizational productivity and an incentive scheme/reward is one of those factors (Aarabi et al., 2013, p. 302). Arnolds and Venter (2007, p. 21) highlight the importance of managers taking into account rewards that employees might consider motivational. If attention is not paid to this, confusion might arise between motivational strategies managers implement to motivate employees and the preference of motivational rewards these employees expect. This can also result in some serious implications between management and personnel, were even a common ground cannot be achieved in trying to realise the organization's goals and objectives. Ude and Coker (2012) suggest that managers make it a priority to identify significant incentive schemes that will best serve as motivators of employees.

The primary reason why people work is to earn a living. Socio-economic issues drive employees to demand more money. Manzoor (2012, p. 38) maintains that the ultimate enticement is money and in relation to its influential value, no other motivational factor or incentive comes even close to it. The issue of remuneration is subjective, however, organizations (such as mining companies) use it, and other incentive schemes such as performance-based bonuses to inspire and improve mineworkers' job commitment (Manzoor, 2012, p. 38). According to Edrak et al. (2013, p. 97), even though some scholars claim that monetary payment is not directly linked with job satisfaction, performance-based payment (merit pay) on the other hand may lead to improved employee performance. However, were does one draw the line when it comes to provision of unreasonable monetary incentives within an organization. According to Kalburgi and Dinesh, (2010, p. 152), monetary incentives and rewards do not as other research studies suggest, exert as much effort in influencing the level of employees' efficiency and productivity.

Personnel require some sense of long-lasting commitment from companies concerning their job security. Employers who always preach on how dispensable workers jobs or services towards the company, are likely to promote a lack of loyalty, motivation and commitment. This could have a significant impact on company goals and objectives (Nyamubarwa et al., 2013, p. 121).

Employee empowerment is a motivational tool used to create a sense of pride and belonging for employees (Stevenson, 2007, p. 417). Empowered employees tend to exert more effort into their work with a sense of enthusiasm, enjoyment and responsibility (Manzoor, 2012, p. 38). Employees can make decisive decisions without any supervision from management. This will build trust and loyalty between managers and workers. Bashir et al. (2012, p. 3) further explain that empowered workers can execute their work in an efficient and effective way, acquire more knowledge and aid in pioneering organizational systems and products.

Recognition also known as employee acknowledgement is one of many types of incentive schemes. Employee recognition in comparison to other incentive schemes is far more cost effective as it provides a comparatively low-cost but has a sufficient-impact as a reward to employees that are performing at a higher

standard within the workplace. Employee recognition can be in a form of acknowledgement for a job well executed; end of the year function where top performers are given prizes as a token of appreciation; certificate and gold name plates (Ude & Coker, 2012, p. 35).

Badenhorst, Cant, Cronje, Du Toit, Erasmus, Grobler, Kruger, Machado, Marais, Marx, Strydom & Mpofu, (2004, p. 187) define communication as a process of exchanging information or messages from one individual to another. It is a systematic way that people can convey and express their ideas, intentions, feeling and opinions. Senders convey the message and to effectively communicate they have to know what message they want conveyed (Badenhorst et al., 2004, p. 187). Therefore, emerging from the foregoing discussion above, we can hypothesise that:

Factor₂: Motivation as a factor of productivity.

H₂: The more mineworkers are motivated, the higher the levels of labour and organizational productivity.

RESEARCH METHODOLOGY

The themes of this study included a first independent variable (human capital investment), a second independent variable (motivation), and a dependent variable productivity. This paper adopted a quantitative research strategy. This allowed the author to examine the relationship between human capital investment and motivation versus identified key production variables. Through purposive (non-probability) sampling technique was used to identify a suitable mining organization. A convenient (non-probability) sampling technique, where the researcher conveniently chooses elements who are willing to participate, was used to determine the sample size of this study (Willemse & Nyelisani, 2015, p. 24). Every Monday of each week, one new team from Upper Ground 2 (UG2) Reef or Merensky Reef would attend a five-day training programme at a central training facility. The objective of the programme was to help mineshaft workers to understand some basic principles of the Impala Platinum's operations. These included teaching mineshaft workers the history of the mine, health and safety standards, how to work cohesively as a team, how they could improve their performance to achieve monthly performance-based bonuses, how the organization requires capital in order to function, how losses are incurred, how profits are made, etc. The researcher travelled at least twice a week, on Wednesdays and Fridays, from Johannesburg to Rustenburg. This ensured that at least two different teams that arrived on a Monday and Tuesday were surveyed on a Wednesday; and the new teams that arrived on a Wednesday and Thursday were surveyed on a Friday. Although all of the members were surveyed as a team, it was essential that the respondents complete the questionnaires independently and without any outside influence. Sometimes only one team would arrive for the training; and on a bad day there would be no team. Once all the necessary data had been collected, it was collated, analysed, and presented.

The author derived the data of a primary nature from a structured questionnaire that was aligned with the research main objective, from speaking to mine management and from content analysis. The researcher drew a sample from the population of mining personnel (miners) in a mining house (Impala Platinum) between June and July 2016. The author invited mining staff (miners - conventional stoping) $n = 318$ out of 868 (workforce) to partake in this study. The gender distribution of miners who participated in this study was 279 (96.2%) males and 11 (3.8%) females, who were surveyed using a structured questionnaire that was printed and distributed accordingly. Representing a 33.6% of the total unit of measure. The research questionnaire was designed to ensure that the information provided by respondents was treated with the utmost confidentiality and anonymity. Experts in the field of study, including management and training facilitators of Impala Platinum, validated the questionnaire. This enabled communication to be much easier and miners making less mistakes. There were other mining personal from the same employment rank – development and ventilation who could have been surveyed but

Statistical Data Analysis

SPSS version 23.0 was performed to measure miners' perception of subsets of human capital investment and motivation against identified key grouping variables of production. Human capital variables – education, training and healthcare. Below is the sample descriptive results of the study.

Table 1: DESCRIPTIVE ANALYSIS – HUMAN CAPITAL INVESTMENT (EDUCATION and TRAINING)

Research items	Strongly disagree – Disagree	Neutral	Strongly agree – Agree
B1: Education and training is very important to me.	4 (1.4%)	3 (1.0%)	280 (97.5%)
B2: My company makes sure that I am well trained.	4 (1.3%)	9 (3.1%)	273 (95.4%)
B3: I think education and training makes me work better.	3 (1.0%)	7 (2.4%)	276 (96.5%)
B4: My company supports and motivates me to be trained and educated.	13 (4.5%)	16 (5.6%)	259 (89.9%)

SOURCE: SPSS VERSION 23.0 (2016)

Table 1 above indicated that 97.5% of the respondents' agreed that education (learning) and training (skills development) was important in improving labour performance. 97.6% of the respondents had a positive acknowledgment of health and safety. This yielded a response rate of 98.3% with an average mean of $\bar{x} = 4.78$ with a std. deviation of 0.602 as indicated in table 2 below. The average mean and standard deviation show that a common consensus was reached among the respondents perception of human capital dimensions – education and training.

Table 2: DESCRIPTIVE ANALYSIS – HUMAN CAPITAL INVESTMENT (EDUCATION and TRAINING)

Research items	N	Mean	Std. Deviation
B1: Education and training is very important to me.	287	4.78	0.602
B3: I think education and training makes me work better.	286	4.67	0.612
B2: My company makes sure that I am well trained.	286	4.62	0.637
B4: My company supports and motivates me to be trained and educated.	288	4.46	0.882

SOURCE: SPSS VERSION 23.0 (2016)

Table 3 below indicated that 97.6% of the respondents had a positive acknowledgment of health and safety. This yielded a response rate of 97.6% with an average mean of $\bar{x} = 4.82$ and a std. deviation of 0.639 indicating that majority of the respondents had a positive acknowledgment of health and safety. However, the results show that 42.7% of the respondents were happy with their monthly salary, 44.5% of the respondents were not happy with their monthly salary, while 12.8% of the respondents were neutral.

Table 3: DESCRIPTIVE ANALYSIS – HUMAN CAPITAL INVESTMENT (HEALTH and SAFETY)

Research items	Strongly disagree – Disagree	Neutral	Strongly agree – Agree
B5: Health and safety is important to me.	6 (2.1%)	1 (0.3%)	279 (97.6%)
B6: My work is not dangerous.	164 (59.6%)	16 (5.8%)	95 (34.5%)
B7: I am not afraid to go to work.	30 (10.8%)	21 (7.6%)	227 (81.6%)
B8: I wear protective clothes when I am at work.	2 (0.7%)	0 (0.0%)	281 (99.3%)
B9: My supervisor explains to me step-by-step health and safety measures.	13 (4.6%)	20 (7.0%)	251 (88.4%)

SOURCE: SPSS VERSION 23.0 (2016)

This yielded a response rate of 96.2%, an average mean of $\bar{x} = 2.89$ with a std. deviation of 1.513. The average mean and standard deviation show that respondents are divided on the issue of remuneration as almost half of the respondents were happy, while the other half were not happy.

Table 4: DESCRIPTIVE ANALYSIS – HUMAN CAPITAL INVESTMENT (HEALTHCARE and SAFETY)

Research items	n	Mean	Std. Deviation
B5: Health and safety is important to me.	286	4.82	0.639
B6: My work is not dangerous.	275	2.58	1.611
B7: I am not afraid to go to work.	278	4.16	1.124
B8: I wear protective clothes when I am at work.	283	4.81	0.444
B9: My supervisor explains to me step-by-step health and safety measures.	284	4.40	0.921

SOURCE: SPSS VERSION 23.0 (2016)

Factor₁: Human capital investment as a factor of productivity.

H₁: The more mineworkers are knowledgeable, highly-skilled, and healthy within the mining company, the higher the levels of labour and organizational productivity.

Human capital investment as a factor of productivity was subjected to the Principal Axis Factoring (PAF), Kaiser-Meyer-Olkin (KMO), Measure of Sampling Adequacy (MSA) and the Bartlett's Test of Sphericity. In the first order of statistical analysis, the researcher subjected 9 items of human capital investment to Principal Axis Factoring (PAF) using SPSS version 23.0. Data suitability was measured before Factor Analysis (FA) could be conducted. After in-depth inspection, the correlation matrix revealed that many coefficients exceeded the recommended standard value of 0.3. The Bartlett's Test of Sphericity was statistically significant as it registered $p = 0.000$, which indicated sampling adequacy and supported the correlation matrix's factorability, while Kaiser-Mayer-Olkin (KMO) yielded 0.713 above the recommended standard value of 0.6. The output generated from the Principal Axis Factoring (PAC) analysis indicated 3 factors that were above the initial eigenvalue of 1.0 (2.493, 1.321 and 1.061). These 3 factors explained a total of 54.169% of the variance. According to Maree (2014:13), if the Initial Eigenvalue is below 1.0 (it would mean less or no dependency and if more than or equals to, it would mean that there is dependency. This was substantiated by the Screeplot chart, it confirmed 3 factors that exceeded the recommended initial eigenvalue of 1.0 even though graphically it is not that clear. Consensus was to retain 3 of these factors for further analysis (Maree, 2014, p. 219-221).

This sub-section of analysis identified research items of human capital investment that were removed and the effect they had on the research outcomes. **B6** had to be removed from factor 3 as it was the only one loading factor. **B7** was removed as it had a 0.119 communality value below the recommended 0.3 and there was no loading in factor 2 on the factor matrix table that was generated. **B8** had to be excluded as it had a 0.131 communality value below the recommended 0.3 and there was no loading in factor of the rotated factor matrix. This was followed by the exclusion of **B5** as it had a 0.118 communality value below the recommended 0.3. **B8** excluded as it registered a 0.223 communality value below the recommended 0.3 and more.

Ultimately, the researcher subjected 4 research items of human capital investment as a factor of performance to Principal Component Analysis (PCA) using SPSS version 23.0. Data suitability was measured before Factor Analysis (FA) could be conducted. After an in-depth review, the Correlation Matrix (*human capital investment components*) revealed that many of the coefficients exceeded the recommended standard value of 0.3. The Bartlett's Test of Sphericity was statistically significant as it registered $p = 0.000$, which indicated sampling adequacy and supported the correlation matrix's factorability, while Kaiser-Mayer-Olkin (KMO) yielded 0.698 above the recommended cut off value. From the statistical output generated from the Total Variance Explained and using Kaiser-Mayer-Olkin (KMO), the study retained 1 factor that was above the Initial Eigenvalue of 1.0 (dependency) (2.086). This 1 factor explained a total shared variance of 52.151%. This was substantiated by the Screeplot chart that clearly confirmed 1 factor that exceeded the recommended initial eigenvalue of 1.0. A decision was reached to retain 1 factor for further analysis. This factor contained 4 research

items that were employed to test if there is a relationship between research items contained in human capital investment (Maree, 2014, p. 219-221). The Component Matrix could not be rotated as research items were highly correlated. The empirical results suggest that there is a positive relationship human capital investment and productivity. The Cronbach Alpha was below the recommended reliability alpha value of 0.7. Human Capital Investment as a factor registered a below reliability alpha value of 0.675. A scale with 4 research items reduced the reliability alpha value significantly. Based on what has been discussed, it was more appropriate to report the mean inter-correlation for the 4 research items of human capital investment as it is common to have a below 0.7 Cronbach alpha value when dealing with research items that are below 10. The inter-item correlations indicated a 0.357 value, which was between the recommended ranges (0.2 to 0.4) (Maree, 2014, p. 219-221).

Factor₂: Motivation as a factor of productivity.

H₂: The more mineworkers are motivated, the higher the levels of labour and organizational productivity.

Motivation as a factor was subjected to the Principal Axis Factoring (PAF), Kaiser-Meyer-Olkin (KMO), Measure of Sampling Adequacy (MSA) and the Bartlett's Test of Sphericity. The first order of analysis was conducted and the researcher subjected 16 research items of motivation to Principal Axis Factoring (PAF) analysis using SPSS version 23.0. Data suitability was also measured before Factor Analysis (FA) could be conducted. After a comprehensive inspection, the correlation matrix (motivation components) discovered that many coefficients exceeded the recommended standard value of 0.3. The Bartlett's Test of Sphericity was statistically significant as it registered $p = 0.000$, which indicated sampling adequacy and supported the correlation matrix's factorability, while Kaiser-Mayer-Olkin (KMO) yielded 0.833 above the recommended standard value of 0.6. Based on the statistical output generated from the Principal Axis Factoring (PAF) analysis using SPSS version 23.0, the total variance explained extracted 4 factors that were above the initial eigenvalue of 1.0 (5.233, 1.794, 1.395 and 1.106) of total variance explained. These 4 factors explained a shared total variance of 48.042%. This was substantiated by the Screeplot chart as it confirmed 4 factors that exceeded the recommended initial eigenvalue of 1.0 even though graphically it is not that clear. Common consensus was to retain 4 of these factors for further statistical analysis. The pattern matrix could not be rotated as research items were highly correlated and some of the research items were not loaded (Maree, 2014, p. 219-221).

This sub-section of analysis identified research items of motivation that were removed and the effect they had on the research outcomes. **C16** had to "be removed" as it had a 0.160 the lowest loading in factor 2. **C21** "was removed" as it had a 0.260 communality value below the recommended 0.3 and had no loading in factor 2. **C17** had to "be removed" as it had a 0.215 communality value below the recommended 0.3 and had the lowest loading of 0.342 in factor 4. Ultimately, the researcher subjected 13 research items of human capital investment as a factor of productivity to Principal Component Analysis (PCA) using SPSS version 23.0. Data suitability was measured before Factor Analysis (FA) could be conducted. After an in-depth inspection, the correlation matrix (motivation components) discovered that many of the coefficients exceeded the recommended value of 0.3. The Bartlett's Test of Sphericity was statistically significant as it registered $p = 0.000$, which indicated sampling adequacy and supported the correlation matrix's factorability, while Kaiser-Mayer-Olkin (KMO) yielded 0.821 above the recommended standard value of 0.6. Based on the statistical output generated from the Principal Axis Factoring (PAF) analysis using SPSS version 23.0, the total variance explained revealed 3 factors that were above the Initial Eigenvalue of 1.0 (4.705, 1.733, and 1.327). These 3 factors explained a total of 50.221% of the shared variance. This was substantiated by the Screeplot chart as it confirmed 3 factors that exceeded the recommended Initial Eigenvalue of 1.0 even though graphically it was not that clear. Common consensus was to retain 3 of these factors for further analysis (Maree, 2014, p. 219-221). A Pattern Matrix Extraction Method (Principle Axis Factoring), Rotation Method: OBLIMIN with KAISER NORMALIZATION. A Factor Correlation Matrix between Job Satisfaction (JS), Adequate Remuneration (AR), and Job Security (JS) contained in Motivation as a factor of productivity consistently yielded ($r = 1.000$ s) (Maree, 2014:219-221). Job Satisfaction (JS), Adequate Remuneration (AR), and Job Security (JS) all support motivation as a factor of productivity. The Cronbach Alpha was above the recommended reliability alpha value of 0.7 and more. The Motivation factor registered an above reliability alpha value of 0.858. The Cronbach Alpha for Job Satisfaction was 0.834 above the recommended reliability alpha value of 0.7. Adequate Remuneration was 0.821 and Job Security was 0.835.

RESEARCH FINDINGS AND DISCUSSIONS

The main empirical results of this study in terms of the theoretical background, suggest that human capital investment (through education, training and healthcare) and motivationally-inclined incentives improve labour and organizational productivity. The aforementioned results corroborate the previous findings that substantiate the significant of investment in human development and employee motivation to improve labour performance and to achieve high levels of productivity, optimise profit, and achieve long-term competitive advantage. For instance, a study by Awan and Sarfraz (2013) found that human capital investment has a strong relation with firm performance and employee's satisfaction mediates the process between both variables. Ude and Coker (2012) found that motivationally-inclined incentives have high significant relationship with employee motivation and productivity. It is important to note that there were other latent variables – the type of reef mined, depth below surface, travelling time, and logistics – that might have worked against the improvement in the mineworkers' labour performance.

LIMITATIONS AND FUTURE RESEARCH

It important to acknowledge that this study was conducted during a time, when the mineral exploration industry was going through a lot of turmoil and great uncertainty. This study focussed on one occupational mining category (conventional stoping) as a single unit of analysis. This project did not cover the entire South African mineral exploration industry and as it was limited only to one platinum mining organization, which further restricts the study's generalisability to other mining companies and industries. Although the study demonstrates internal validity, this opens opportunities for future research studies to be conducted on other mining occupations and industries, to further alleviate the generalizability across all mining companies and mining industries in South Africa, and across the African continent.

PRACTICAL IMPLICATIONS

From a practical perspective, the following managerial implications arise:

- Based on empirical findings, it can be reasoned that mining houses cannot dismiss the awareness and significance of investing in human development and motivation to better enhance labour productivity, improve organizational productivity, optimise profitability and achieve competitive advantage.
- Mining houses should consider including mining personnel in structuring flexible remuneration packages that will further induce mineworkers to exert more effort into their work. This will make mineworkers' feel more appreciated, and that they are part of an essential system that values its workforce. In addition, this will kerb industrial unrests within the mining industry.
- Mine management should ensure that there is complete transparency, and that mineworkers are informed of any critical decisions that might impact on their future. This would indicate to miners that they are adding value and are considered an essential part of Impala Platinum, and not just a cost to the organization.
- The industry has the reputation of being dangerous. As a result, it attracts fewer and fewer female miners. Another perception is that, for one to perform underground, one needs to be masculine – that is, strong and rough. Mining companies could challenge the masculine stereotype by employing more female miners. From a general perspective, this could change the whole mineral exploration industry, particularly with respect to safety.
- The South African Mining Charter and the mining companies should make it compulsory for mining personnel to own their own homes, even if they are in hostels. This would indicate to the miners that mining companies care for their social development and well-being. This would also ensure that mineworkers are closer to their workplaces, thus contributing to employee motivation, improved labour performance, enhanced organizational productivity, and optimised profitability.

CONCLUSION

Broadly speaking, this paper has contributed significantly towards the field of human capital investment, motivation and productivity by targeting mining personnel (miners) within the mineral exploration industry in South Africa. Furthermore, this study has provided a sound and comprehensive understanding of literature, theory and empirical findings to mining organizations. This study sought to examine the effect of human capital investment and motivation on mineworkers' productivity within a South African Platinum mine context. Stemming from the theoretical evidence and empirical research findings, it can be deduced that human capital investment and motivation have a direct impact on labour and organizational productivity. The fundamental value of this paper was to make mining companies (such as Impala Platinum) aware that sustainable development in miners' abilities within the mineral exploration industry is feasible, through an integration of human capital investment, motivation, and performance (productivity).

REFERENCES

- Aarabi, M.S., Subramaniam, I.D., & Abu Baker Akeel, A.B.A. (2013). Relationship between Motivational Factors and Job Performance of Employees in Malaysian Service Industry. *Asian Social Science*, 9(9), 301-310.
- Adekola, I.A. (2014). Public Investment in Human Capital and Economic Growth in Nigeria: Analysis on Regime Shifts. *Journal of Economic and Development Studies*, 2(2), 213-23.
- Arnolds, C.A., & Venter, D.J.L. (2007). The Strategic Importance of Motivational Rewards for Lower-Level Employees in the Manufacturing and Retailing Industries. *SA Journal of Industrial Psychology*, 33(3), 15-23.
- Awan, M.A.S., & Sarfraz, N. (2013). The Impact of Human Capital on Company Performance and The Mediating Effect of Employee's Satisfaction. *Journal of Business and Management*, 8(2), 76-82.
- Badenhorst, J.A., Cant. M.C., Cronje, J., Du Toit. G.S., Erasmus. B.J., Grobler. P.A., Kruger. L.P., Machado. R., Marais. K., Marx., Strydom. J.W., & Mpofu. R.T. (Editors). (2004). *Introduction to Business Management*. Sixth edition. Cape Town South Africa: Oxford University Press.
- Barr, R., & Cook, R.E. (2009). Mining for operational excellence. Available from: http://iom.invensys.com/EN/pdfLibrary/NewsArticle_Invensys_MiningforOperationalExcellence_11-09.pdf [Accessed 20 August 2015].
- Bashir, I., Ahmed, K., & Hashim, R. (2012). Correlation between human capital and financial capital in developing countries: Case of Pakistan. *Interdisciplinary Journal of Contemporary Research in Business*, 4(2), 1-13.
- Bhoola, U. (2011). National Labour Law Profile: South Africa. Available from [http://www.ilo.org/ifpdial/information-resources/national-labour-law-profiles/WCMS_158919/lang--en/index.htm](http://www.ilo.org/ifpdial/information-resources/national-labour-law-profiles/WCMS_158919/lang-en/index.htm) [Accessed 25 February 2015].
- Boroujerdi, R.Y., Siadat, S.A., Hoveida, R., & Khani, S. (2014). The study of the nature of human capital management and its strategic role in achieving of competitive advantage for the organization. *International Journal of Scientific and Research Publications*, 4(5), 1-5.
- Cairns, P. [23 September 2015]. South Africa's 12 top priorities. The citizen, page 22.
- Cetin, I. (2013). Motivation and Its Impact on Labour Productivity at Hotel Business "Conceptual Study". *International Journal of New Trends in Arts, Sports & Science Education*, 2(1), 70-79.
- Chaudhary, N., & Sharma, B. (2012). Impact of Employee on Performance (Productivity) In Private Organization. *Electronic version, International Journal Business of Trends and Technology*, 2(4), 29-35.

- Chipunza, C., Samuel, O.M., & Mariri, T. (2011). Leadership style, employee motivation and commitment: Empirical evidence from a consolidated retail bank operating in a depressed economy. *African Journal of Business Management*, 5(20), 8337-8346.
- Colombo, E., & Stanca, L. (2008). The Impact of Training on Productivity: Evidence from a Large Panel of Firms. Available from: <https://ideas.repec.org/p/mib/wpaper/134.html> [Accessed 17 March 2017].
- Dae-Bong, K. (2009). The 3rd OECD World Forum on Statistics, Knowledge and Policy Charting Progress, Building Visions”, Improving Life: Human Capital and Its Measurement. Available from: <http://www.oecd.org/site/progresskorea/44109779.pdf> [Accessed 13 April 2015].
- Du Plessis, A.J., Keovilay, P., Marriot, J.R., & Seth, N. (2015). Effective motivation practices that could enhance employee performance in the mining industry. Available from: <http://unitec.researchbank.ac.nz/handle/10652/3374> [Accessed 3 March 2017].
- Dubrin, A. (2009). *Essential of Management*. Eighth edition. United States of America: Cengage Learning.
- Edrak, B.B., Ying-Fah, B.C., Gharlegghi, B., & Seng, T.K. (2013). The Effectiveness of Intrinsic and Extrinsic Motivations: A Study of Malaysian Amway Company’s Direct Sales Forces. *International Journal of Business and Social Science*, 4(9), 96-103.
- Els, F. (2014). Nigeria, South Africa partner on artisanal gold mining. Available from: <http://www.mining.com/nigeria-south-africa-partner-to-develop-gold-mining-nigerian-news-from-leadership-newspapers-87749/> [Accessed 17 September 2015].
- Greasley, A. (2009). *Operations Management*. United States of America: John Wiley and Sons.
- Gross, R. (2015). HUMAN CAPITAL INVESTMENT THEORY AND THEORY OF REASONED ACTION: THE INFLUENCE OF ORGANIZATIONAL TRAINING ON EMPLOYEE TURNOVER. *International Journal of Economics, Commerce and Management*, 3(2), 1-11.
- Hansson, B., Johanson, U., & Leitner, K. (2004). The impact of human capital and human capital investments on company performance. Evidence from literature and European survey results. Available from: http://www.cedefop.europa.eu/files/BgR3_Hansson.pdf [Accessed 17 March 2017].
- Heizer, J., & Render, B. (2006). *Operations Management*. Eighth edition. United States of America: Pearson Prentice Hall.
- Kalburgi, M.J., & Dinesh, G.P. (2010). Motivation as a Tool for Productivity in Public Sector Unit. *Asian Journal of Management Research*, 1(4), 32-39.
- Kuranchie-Mensah, E.B., & Amponsah-Tawiah, K. (2016). Employee Motivation and Work Performance: A competitive Study of Mining Companies in Ghana. *Journal of Industrial Engineering and Management*, 9(2), 255-309.
- Lebeloane, M. (2016). Human Capital Development Sibanye Rustenburg Platinum Conventional Campus. Cadetship Training Recruitment Procedure. [Accessed 08 March 2017].
- Lunenberg, F.C. (2011). Expectancy Theory of Motivation: Motivating by Altering Expectations. *International Journal of Management, Business, and Administration*, 15(1), 1-6.
- Manzoor, Q. (2012). Impact of Employees Motivation on Organizational Effectiveness. *European Journal of Business and Management*, 3(3), 1-12.
- Maree, K. (Editor). (2014). *First Steps in Research*. (Revised edition.). Pretoria South Africa: Van Schaik.

Marimuthu, M., Akokiasamy, L., & Ismail, M. (2009). Human capital development and its impact on firm performance: Evidence from developmental economics. *The Journal of International Research*, 2(8), 265-272.

Masia, U., & Pienaar, J. (2011). Unravelling safety compliance in the mining industry: examining the role of work stress, job insecurity, satisfaction and commitment as antecedents. *SA Journal of Industrial Psychology/SA Tydskrif vir Bedryfsielkunde*, 37(1), 1-10.

Mbwaaalala, R.N. (2013). Can labour law succeed in reconciling the rights and interests of labour broker employees and employers in South Africa and Namibia?. Available from: http://etd.uwc.ac.za/xmlui/bitstream/handle/11394/3006/Mbwaaalala_MPHIL_2013.pdf?sequence=1 [Accessed 9 September 2015].

Mining Qualification Authority (MQA) Annual Report (2014 – 2015). Available from: <http://www.mqa.org.za/sites/default/files/MQA%20Annual%20Report%202015.pdf> [Accessed 28 August 2015].

Motsoeneng, L., Shultz, C., & Bezuidenhout, A. (2013). Skills Needed by Engineers in the Platinum Mining Industry in South Africa. Available from: http://uir.unisa.ac.za/bitstream/handle/10500/13876/13R0045M%20Picmet%20Artikel_Motsoeneng.pdf?sequence=1 [Accessed 25 June 2015].

Muogbo, U.S. (2013). The Impact of Employee Motivation on Organizational Performance (A Study of Some Selected Firms in Anambra State Nigeria). *The International Journal of Engineering and Science*, 2(7), 70-80.

Nyamubarwa, W., Mupani, H., & Chiduro, C. (2013). An analysis of the Human Resource practices in the mining industry in Zimbabwe's Midlands Province: A relook at the Resource Based View of managing Human Resources. *Journal of Humanities and Social Science*, 17(1), 116-123.

Olayemi, O.S. (2012). Human Capital Investment and Industrial Productivity in Nigeria. *International Journal of Humanities and Social Science*, 2(16), 298-307.

Raineri, A. (2016). Linking human resources practices with performance: the simultaneous mediation of collective affective commitment and human capital, *The International Journal of Human Resource Management*, DOI: 10.1080/09585192.2016.1155163.

Ravi, T.S. (2015). Impact of labour incentives on productivity in selected Chennai-based manufacturing companies. *Abhinav International Monthly Refereed Journal of Research in Management & Technology*, 4(2), 22-32.

Rusinovci, X. (2015). The effects of persistent training and development on personnel performance and productivity. *International Journal of Management and Business Economics (IJMBE)*, 4(4), 104-112.

Saunders, I. (2013). The South African labour market: All the facts. Available from: http://groundup.org.za/article/south-african-labour-market-all-facts_842 [Accessed 6 August 2015].

Schultz, W.T. (1971). *Investment in Human Capital: The Role of Education and of Research*. New York: Free Press.

Shomos, A., (2010). Links between Literacy and Numeracy Skills and Labour Market Outcomes, Productivity Commission Staff Working Paper, Melbourne, August.

South African Institute of Race Relations (SAIRR): Billions lost due to strike. Available from: <http://www.iol.co.za/business-report/companies/sa-mines-lost-billions-during-strikes-1498824> [Accessed 11 April 2013].

Stevenson, W.J. (2007). *Operations Management. International Student Edition with Global Readings*. Ninth edition. Avenue of the Americas, New York: McGraw-Hill/Irwin.

Twala, C. (2014). The Marikana Massacre: A Historical Overview of the Labour Unrest in the Mining Sector in South Africa. *South African Peace and Security Studies*, 1(2), 61-67.

Ude, U., & Coker, M.A. (2012). Incentive Schemes, Employee Motivation and Productivity in Organizations in Nigeria: Analytical Linkages. *IOSR Journal of Business and Management (IOSRJBM)*, 1(4), 32-39.

Underground Mining Regulations made under Section 82 of the Occupational Health and Safety Act. S.N.S. 1996, c. 7. O.I.C. 2008-306 (June 3, 2008, effective August 1, 2008), N.S. Reg. 296/2008. As amended to O.I.C. 2015-96 (March 31, 2015, effective April 1, 2015), N.S. Reg. 140/2015. Available from: <https://novascotia.ca/just/regulations/regs/ohsmine.htm>. [Accessed 28 November 2016].

Willemse, I., & Nyelisani, P. (2015). *Statistical Methods and Calculation Skills*. Fourth edition. Cape Town: Juta and Company (Pty) Ltd.

Yamoah, E.E. (2014). The Link between Human Resource Capacity Building and Job Performance. *International Journal of Human Resource Studies*, 4(3), 139-146.

EMPLOYEE ENGAGEMENT IN THE TRADE UNION FEDERATION(S) VERSUS MANAGEMENT SAGA IN THE SOUTH AFRICAN MINERAL EXPLORATION INDUSTRY

Lucky Boy Tebogo Makhubedu, Eveth Nwobodo-Anyadiegwu and
Charles Mbohwa
University of Johannesburg, South Africa

ABSTRACT

There is a growing perception within South Africa's mineral exploration industry that mineworkers have lost trust in trade unions due to their absence of engagement pertaining to representation and bargaining council. Despite union membership in the mining sector gradually declining from 421 000 to 301 000 over the past 10 years, trade unions have an ability to stimulate mineworkers and impact on daily operational performance. The principle aim of this study was to establish whether there is a trust deficit amongst mineworkers and trade union representatives, and how this impacts on labour and organizational performance. This study was quantitative and descriptive. A valid research instrument was used to collect data. The target area – Platinum Mining industry in South Africa, focussing on one occupational mining category. Sample descriptive analysis was utilised to answer the main research question. The statistical findings corroborated the main research question tested.

Keywords: Trade Union Federation(s), Performance, Mineworkers, Mining, South Africa.

INTRODUCTION

Most employees have voiced their distrust and have made accusations about representatives from different trade union federations colluding with management. The disappointment is mostly attributed to the trade union's willingness to compromise on workers' rights and interests or demands (Barbeau, 2013, p. 7). The unprotected labour unrest witnessed in the mining industry, in South Africa – a result of mineworkers not acting in accordance with certain provisions that are stipulated in Labour Relations Act (LRA) No. 66 of 1995 – has negated a peaceful and sustainable working environment (Samuel, 2013, p. 255). The tragic events that transpired at Lonmin Platinum in Marikana in 2012 were a result of labour unions failing to represent mineworkers' grievances effectively within the workplace (Twala, 2014, p. 63).

According to Antin (2013, p. 1), the labour unrest, at the Marikana area, which left 34 miner killed and 78 wounded by the South African police, arose from a background of socioeconomic disparities, inequality, high unemployment rate, and poor public service delivery (Twala, 2014, p. 65). Regrettably, repercussions from Marikana, paved the way for other industries, such as the sugar, metal (steel), and engineering sectors, to experience industrial unrest (Mirrian, 2014, p. 1). Mirrian (2014) noted that car manufacturers – BMW (SA), General Motors (SA), Ford, Mercedes-Benz and Toyota – had to halt operations at their production plants due to the metal and engineering workers being on strike. The South African Institute of Race Relations (SAIRR) (2013) reported that coal production had a deficit of over R180 million, and gold and platinum production lost over R10 billion during the industrial action.

Labour Relations Act (LRA) describes a strike as a group of employees who partially or completely refuse to work due to certain work related grievances that they might have with their employers (Bhoola, 2011, p. 16).

It is important that employees benefit from their companies. Workers join trade union movements with the hope of taking advantage of the wage premium linked with union membership, and to have their rights protected. Bargaining councils may be formed by registered trade unions and employers' organizations to participate in the legislative policies of collective bargaining and wage determination in the Republic of South Africa's labour market. Wage determination in South Africa's labour markets can take place through bargaining council agreements, sectoral determination, and non-statutory collective bargaining (Dhliwayo, 2012, p. 2). Samuel (2013, p. 240) observes that the entire bargaining process between representatives of all the parties concerned – also known as 'collective bargaining' – was intended to achieve a common agreement.

To understand some of the labour issues that are emerging within South Africa's mineral exploration industry, it is imperative to look at the past, since some of these issues are embedded in it (Bhoola, 2011, p. 3). Notable is the fact that these underlying labour market issues date back to May 1910, when the partnership between the British, the former Boer Republics of the Transvaal and Orange Free State, and the colonies of the Cape and Natal led to the formation of the Union of South Africa (the historical predecessor to the Republic of South Africa). It prompted the adoption of a new constitution that excluded the rights of black South Africans and prioritised the interests of whites (Budeli, 2009, p. 5).

According to South African History Online (Apartheid Legislation 1850s – 1970s), the Mines and Work Act No. 12 of 1911, also known as the 'Colour Bar Act', under section 4(n) gave mine managers' powers to grant, suspend and cancel competency certificates. Furthermore, it gave them powers to decide which mining jobs required competency certificates. Skilled white immigrants ensured that the Act came into effect because they dreaded having to compete with the majority black mining staff. Black miners were not able to produce competency certificates due to their lack of education and unfavourable training policies, and were thus excluded from all skilled and semi-skilled occupations. This adversely affected black miners' potential to succeed, and restricted any improvement in their living standards (Festus, Kasongo, Moses & Yu, 2015, p. 2). The Mines and Work Act also prohibited labour unrest by black miners and excluded them from the legislation. This triggered the establishment of the South African Native National Congress (SANNC), which gave birth to one of the most popular black political parties in the Republic of South Africa – the African National Congress (ANC) (Budeli, 2009, p. 5).

In as much as trade union federations are essential in processes of collective bargaining, employees should be given the opportunity to engage directly with management. It is very important that management also engage workers in decision-making processes (Chaudhary & Sharma, 2012, p. 31). The term negotiation is considered a decision making tool that management can employ to identify individual problems and solutions. When workers are excluded around the negotiation table, even though they are represented, trying to meet a mutual agreement that is beneficial to all parties concerned, it becomes highly unlikely. Trade union federations' affiliation to the ruling party, it creates a conflict of interest between workers and management. Corruption, union breakaways, infighting, and power struggles between members highlight how insignificant workers have become (Dhliwayo, 2012). According to Mining Review Africa (2014, p. 3), this turf war between the Association of Mineworkers and Construction Union (AMCU) and the National Union of Mineworkers (NUM), had an adverse effect on mining production and South Africa's gross domestic product (GDP). Clearly, wildcat strike actions are detrimental to mining companies and the economy as a whole. Until we stop with the traditional ways of doing things, there will be no progress.

Emerging from the foregoing discussion, the purpose of this paper was to investigate if there is a trust deficit among mineworkers' and trade union federation(s) pertaining to representation and bargaining council and how this impacts on miners' labour performance.

LITERATURE REVIEW

History of Mining in South Africa

In the Witwatersrand basin in the late 19th century, what later became South Africa began the transformation from a dominantly agricultural territory to becoming one of the most industrialised and highly unionised nations

on the continent. Historically, the mineral exploration industry has been the heartbeat of South Africa's economic growth (Antin, 2013, p. 1). The industry has attracted significant foreign investment since the early 1900s, and has created more employment opportunities than any other sector (Masia & Pienaar, 2011, p. 1). In 1886, when the Witwatersrand goldfields were discovered, a watershed moment in the history of mining occurred, giving birth to what became the modernised, industrialised South Africa (Antin, 2013, p. 3). At that time, the gold mining sector drastically improved the region's economy and integrated its labour market across the board. The gold market was available, and gold was very expensive. As the process of extraction began to require deep-level mining, expensive high-tech systems had to be used. Entrepreneurs (Randlords) who controlled the diamond and gold mining industries benefitted financially from the Witwatersrand goldfields. They dominated the mining industry as international investors provided them with support in the form of capital. Entrepreneurs founded six mining companies to maintain a stranglehold on the gold boom, whilst securing the future expansion of the industry. The Anglo-America Corporation of South Africa, who joined the gold rush in 1917 – funded by the New York Bank (later called JP Morgan) – was the game changer, and controlled the industry (Harrison & Zack, 2012, p. 551-554).

Historical View of Platinum

According to the Chamber of Mines of South Africa, the first known discovery of platinum was in ancient Egypt around 700BC, where the metal was used in artefacts. In South America, dating back to 1500s, the Spanish Conquistadors found many occurrences of what they termed platina while they were extracting gold using the gold panning process. In Europe, scientists not only found it difficult to categorise this precious metal, but – because of its durability – they also could not determine how to use it. Around the 18th century there was a breakthrough when a Swedish researcher added arsenic (a poisonous metallic element) to the metal, and only in 1782 was platinum successfully melted by adding oxygen. Adolf Erasmus discovered the first pieces of platinum in South Africa in 1923, near Naboomspruit in the central Transvaal. Follow-up work by Dr Hans Merensky, a German geologist, resulted in the discovery of two deposits, each around 100 kilometres in length, which became known as the Bushveld igneous complex, illustrated below.

Figure 1: Location – Geology and mines of the Bushveld complex

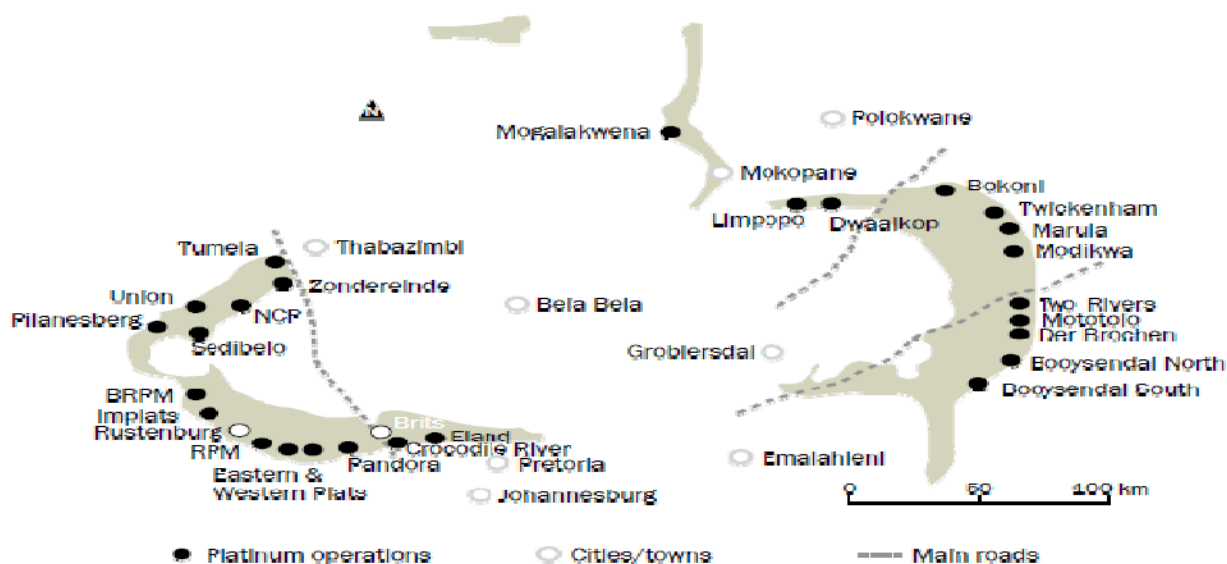

Source: <http://www.chamberofmines.org.za/sa-mining/platinum>

The Bushveld complex, formed some two billion years ago, is located in the northern part of South Africa, and is the world's largest layered intrusion. This igneous body hosts more than half the world's platinum group metals, and associated minerals such as chromium, vanadium, and refractory minerals (<http://www.chamberofmines.org.za/sa-mining/platinum>).

History of South Africa's Trade Union Movement

South Africa's trade unions, in the past, were reserved for white people only, with associations like the South African Confederation of Labour (SACOL) in favour of occupational policies that depended on racial discrimination. Trade unions representing blacks started to come into existence around 1917, and it took about two years for the community of Cape Town to establish the Industrial and Commercial Workers' Union of South Africa (ICU). By the 1930s, the South African Trade and Labour Council (SATLC) had united much of the country. It was explicitly against any form of racism, and affiliated itself with black trade unions. In the 1940s, other black trade unions joined the Council of Non-European Trade Unions (CNETU). By the end of 1945 it had 119 unions as members and around 158 000 individual members. CNETU was disbanded in 1954 (Historybuffs, 2015, p. 2). South Africa's brief history of trade unions highlights the particular degree to which trade union movements have been inextricably associated with the anti-apartheid struggle, and positions them as essential agents in the fight for a constitutional government. At present there are 22 unions in the Federation of Unions of South Africa (FEDUSA) with 560 000 members. The Congress of South African Trade Unions (COSATU) with 1.8 million members, the National Council of Trade Unions (NACTU) with 400 000 members, and the Confederation of South African Workers' Unions (CONSAWU), affiliated with the World Confederation of Labour (WCL), operate at a national level (Bhorat, Naidoo & Yu, 2014, p. 5).

Congress of South African Unions (COSATU)

The Congress of South African Trade Unions (COSATU) is conceivably the fastest growing trade union movement with more than 2 million members, 21 affiliated unions and its power is derived from its ability to marshal workers, regional and international credibility, size of affiliated union members and strong historic ties with the ruling party (Bhorat et al., 2014, p. 5). COSATU was established in 1985 through an amalgamation of unions and federations. COSATU played a pivotal role in the struggle against apartheid. COSATU has a strategic political alliance with the South African Communist Party (SACP) and the African National Congress (ANC). When political organizations were unbanned, in early 1990, COSATU, SACP and the ANC formed a tripartite alliance. The principal objective of the alliance was to establish a democratic and non-racial South Africa, economic transformation and continued process of political and economic democratisation (Dhliwayo, 2012, p. 1). This implied though not yet expressed political contract between the alliances has sustained its political position since the ANC came into power in 1994. The Reconstruction and Development Plan (RDP), originally drafted by COSATU, described the ANC's 1994 election manifesto. Not only was COSATU instrumental in outlining the RDP, it also released 20 of its leaders to stand as parliamentary candidates on the national list of the ANC and election to provincial legislature in 1994. Some leaders of the federation stood in the local government election in 1995 (Bhorat et al., 2014, p. 16).

According to a report by Adcorp (2013, p. 1), South Africa's trade unions are in a critical period. Currently, only one in four workers – 25.5% of the labour force – is unionised, and this figure is slowly decreasing. Less than half of the people who join the labour market for the first time, or 43%, are joining trade union movements. The industry sectors with the largest labour force have been shedding union members. Union membership in the mining sector has gradually declined from 421 000 to 301 000 from 2005 to 2015. South Africa has a trade union density rate of slightly over 30%. While this is not bad by international standards, it is still far too low. A trade union density of 30% means that two out of every three workers are not unionised. The federation has a huge task ahead, especially among the most vulnerable and exploited workers. According to figures compiled by SAIRR (2013), in the 12 years from 2000 to 2012, the rate of unionisation in South Africa increased by 12%, from 26% to 29%. The most unionised sector in 2000 was mining and construction at 34%. The most unionised sector in 2012 was the community, social services, and utilities sector (dominated by public sector employees) at 47%. Trade union membership grew by 18% in this sector over the period, while it decreased in the mining and construction, trade, and finance sectors.

Key employment laws such as the Labour Relations Act (LRA) of 1995, the Basic Conditions of Employment Act (BCEA) of 1997, the Employment Equity Act (EEA) of 1999, and the Skills Development Act (SDA) are there to protect employees. However, the negative spin-off was that potential investors were scared off; and that has been counterproductive. Small, medium and micro-enterprises (SMMEs) find it difficult to meet the requirements of these Acts (Dhliwayo, 2012, p. 2).

COSATU notes that HIV and AIDS is one of many challenges facing South Africa today. Of the 48 million South Africans in the 2011 census study, 5 700 000 people were estimated to be HIV-positive, with a prevalence rate in the 15- to 49-year-old age bracket. Of 18.1%, most of these are women (3 200 000) in urban and rural informal environments, and 334 000 are children (COSATU, 2013).

Failures of Trade Union Federation(s)

Unfavourable economic conditions and a largely unskilled labour market have seemingly made life difficult for South Africa's trade unions. Due to the failure of the government to reduce unemployment, COSATU has found it difficult to support and justify ANC policies. The fact that some unions have parted ways with COSATU, and the reduction in union members over the years, are indicative of a conflict of interest growing within the federation (Dhilwayo, 2012, p. 2). Dhilwayo (2012) adds that in 2001 mineworkers were dissatisfied with NUM, leading to the formation of the Association of Mineworkers and Construction Union (AMCU). Infighting and bickering within the NUM has seen the federation lose credibility among its members, leading some to join AMCU. NUM's strong ties with the government were also a factor, as it was seen as a way to acquire powerful positions in government structures. Not being able to deal with socio-economic issues has led mineworkers to lose confidence in COSATU; and the aftermath of the tragic events at Lonmin Platinum's Marikana mine in 2012 hit the federation hard. COSATU's strong affiliation with the ruling party makes it a powerful federation in South Africa. However, union breakaways, infighting, and power struggles between members highlight how insignificant mineworkers have become. The main objective of COSATU, NUM, AMCU, and all the other labour federations was to represent the interests of workers; but instead they are looking out for their own interests. There is insufficient trust between mineworkers', trade unions, mine communities, mine owners, and the government (Dhilwayo, 2012).

Key Employment Policies

Since 1996, South Africa's constitution has introduced three historic principles that underpinned its occupational laws. The state demanded to form a non-racial, non-sexist and an open-minded area prioritising equality. Despite the progress made in getting the economy back onto a higher path, the mining industry in South Africa faces key employment challenges – employee relations and lack of transformation (Mokoena, 2013). It is essential for companies to have policies in place that clearly stipulate how workers should conduct themselves to have a good employer-employee relationship within the organization. According to Tansel and Gazioglu (2013, p. 2), a mutually beneficial relationship between an employer and employee is key to the performance of any organization and for workers to feel engaged. There should be a balance between employees' degree of autonomy in their work territory in contrast to management's hierarchical domination towards the goals of the company. An imbalance can negatively affect loyalty and productivity of personnel. Tansel and Gazioglu (2013) further outline other significant employment laws affecting the employer – employee relationship within the mineral exploration industry. Key employment regulations – the Labour Relations Act (LRA) discussed in the introduction, Basic Conditions of Employment Act (BCEA), Compensation for Occupational Injuries and Diseases Act (COIDA), Occupational Health and Safety Act (OHSA) and Employment Equity Act (EEA) are only a selected few that mining companies can use to govern their place of work.

The Basic Condition of Employment Act No.75 of 1997 applies to all employees and employers in a workplace and overlooks employees of the National Defence Force, National Intelligence Agency, South African Secret Service and unpaid volunteers. The basic conditions included in the act forms a binding contract between an employer and employee. It compels the employer to offer the employee with a detailed employment contract. Basic conditions included in the contract are normal working hours, overtime, compressed workweek, the

average work hours, lunch intervals, daily/weekly rest period, night shift and public holidays, and compensation for working on Sundays (Bhoola, 2011, p. 11).

The Compensation for Occupational Injuries and Diseases Act No. 61 of 1997 (COIDA) allows for the provision of compensation to help operatives who sustain injuries, are disabled, or contract occupational illnesses in the workplace (Bhoola, 2011).

Bhoola (2011, p. 12) argues that transformation in any sector is a challenging and provocative issue. Placing people in certain occupational positions based on colour and not on merit is a form of discrimination. Bhoola (2011, p. 12) further emphasises that the Employment Equity Act No. 55 of 1998 (EEA) aims to promote the creation of equal opportunity for all personnel, job seekers, and employers by eradicating any form of unfair discrimination in the workplace. It also focuses on redressing historical imbalances experienced by indigenous or designated groups through the implementation of affirmative action measures. The Employment Equity Act requires employers to conduct an analysis of the organization's workforce; have consultations with workers and trade unions regarding matters of salary and wage negotiations, working conditions, etc.; identifying obstructions towards the accomplishment of equality in the labour force; preparing and implementing employment equity plans; and reporting the status and development to the department of labour. Organizations that fail to comply with the Employment Equity Act can be fined up to R500 000 for a first-time offence (Kowalik, 2007, p. 1). The primary objective of the EEA is to ensure that there is workplace impartiality, equal opportunity, fair treatment of employees, and a prohibition of unfair discrimination within the work environment (Bhoola, 2011).

RESEARCH METHODOLOGY

The study adopted a quantitative research approach. This research design was best suited for this particular study, as it addressed the descriptive nature of study (Masia & Pienaar, 2011, p. 4). In addition, a purposive (non-random) sampling technique was used to identify a suitable mining organization. A convenient (non-random) sampling technique, where the researcher chooses elements who are willing to participate, was used to determine the sample size of this study (Willemse & Nyelisani, 2016, p. 24). A standardised questionnaire based on a five-point Likert scale was used to gather as much data as possible from a large group of respondents. A purposive sampling technique was used to identify a suitable mining organization. A convenient sampling technique, where the researcher accessibly selects elements from the population who are willing to participate, was used to determine the sample size of the study (Willemse & Nyelisani, 2015:24). Of the population (conventional mining crews) of $N = 868$ miners, a sample of $n = 306$ miners participated in this study. However, one of the teams, consisting of 16 members who completed the research questionnaire, had to be left out of this study, as they were newly-formed and did not have a performance report for 2015 and 2016. The sample consisted of 279 men (96.2% of the sample) and 11 women (3.8%) who were surveyed using a standardised questionnaire that was printed and distributed accordingly. This yielded a survey response rate of 33.6%. The research questionnaire was administered to mineshaft workers (conventional stoping) in Marikana, Rustenburg, South Africa. Primary data was collected using a structured questionnaire with a five-point Likert scale to rate management aspects of trade union federation between "strongly disagree" and "strongly agree". To measure consistency and reliability among the variables, the Principal Axis Factoring (PAF), Kaiser-Meyer-Olkin (KMO), Measure of Sampling Adequacy (MSA) and the Bartlett's Test of Sphericity were performed. The first order of statistical analysis was conducted and the researcher subjected three research items of trade union federation(s) to Principal Axis Factoring (PAF) analysis using SPSS version 23.0. Data suitability was also measured before Factor Analysis (FA) could be conducted. After a comprehensive inspection, the correlation matrix (trade union components) discovered that all coefficients were above the recommended value of 0.3. The Bartlett's Test of Sphericity was statistically significant as it registered $p = 0.000$, which indicated sampling adequacy and supported the correlation matrix's factorability, while Kaiser-Mayer-Olkin (KMO) yielded 0.737 above the recommended standard value of 0.6. Based on the statistical output generated from the Principal Axis Factoring (PAC) analysis using SPSS version 23.0, the total variance explained extracted one factor that was above the Initial Eigenvalue of 1.0 (2.477). This one factors explained a total shared variance of 74.162%. This was substantiated by the Scree plot chart as it confirmed one factor that exceeded the recommended initial eigenvalue of 1.0. Trade Union Federation (TUF) as factor of performance contained three research items that were employed to test the association between the research items contained in Trade Union Federation(s) as a

factor of performance. The Component Matrix could not be rotated as research items were highly correlated. The Cronbach Alpha for Trade Union Federation was 0.892 above the recommended reliability alpha value of 0.7.

Statistical Data Analysis: Demographic Profile

The data collected from all the participants was summarised into frequency distribution tables to give an overview of the information that was collected. Percentage frequencies were calculated and documented accordingly. The aim was to gain insight into how the participants' perceptions and experiences differ according to certain demographic groupings. Statistical findings are presented below:

In terms of gender distribution within the mining organization (i.e. Impala Platinum), the statistical analysis show that of 292 respondents who completed the questionnaire, 96.2% of the participants were male, while 3.8% of the participants were female. It can be adduced from the findings that the mining industry is mostly male-dominated compared to other industries in South Africa. There is a masculine-stereotype (rough and tough), that assumes for one to perform or excel, one needs to be macho and strong. From a general perspective, the mining industry has a reputation of being dangerous (Masia & Pienaar, 2011:1) and as a result, it has seen fewer women-miners hired by mining companies. The highest level of education attained by the respondents working at Impala Platinum. The survey results indicate that 63.7% of the respondents have Standard 6/Grade 8 and above. 36.3% of the respondents have a Standard 5/ Grade 7 and below. 27.1% of the respondents have attained a Standard 10/ Grade 12 certificate. While 6.5%, have no formal education. 49.1% of the respondents have standard eight/ Grade 10 or above. The mineral exploration industry, working with the ruling party has seen vast improvement in literacy of mineworkers. Unemployment has also contributed to improvement in literacy as more and more people seek employment in the mining sector. The survey results paint a picture of an improving literacy in the mining sector.

Questionnaire items (C26), (C27), and (C28) (see Table 1 below), set out to inquire on respondents perception of trust of the trade union federation(s) within the mining organization (i.e. Impala Platinum). These items answer the main objective of the study: **Is there a trust deficit among mineworkers and trade union federation(s), and how does it impact on miners' labour performance?**

Table 1: DESCRIPTIVE ANALYSIS –TRADE UNION FEDERATION(s)

Research items	Strongly disagree – Disagree	Neutral	Strongly Agree – Agree
C26: I trust my trade union federation(s).	40 (14.1%)	30 (10.6%)	214 (75.3%)
C27: I can talk to my trade union federation(s).	28 (9.9%)	26 (9.2%)	229 (80.9%)
C28: I am happy with my trade union federation(s).	41 (14.3%)	36 (12.6%)	209 (73.1%)

Source: (Statistical calculation from SPSS analysis: 2016)

Questionnaire item (C26): An inquiry was made to find out how respondents perceive their trade union federation(s) pertaining to trust and the survey results indicate that 75.3% of the respondents have complete trust in their trade union, 14.1% of the respondents had lost trust in their trade union federation(s), while of the respondents 10.6% of the respondents were neutral. This yielded a response rate of 96.9% with an average mean of $\bar{x} = 4.12$ and a std. deviation of 1.067. Questionnaire item (C27): A significant number 80.9% of the respondents attest that they can communicate with their trade union federation(s), 9.9% of the respondents had problems communicating with their trade union federation(s), while 9.2% of the respondents were neutral. This yielded an overall response rate of 96.9% with an average mean of $\bar{x} = 3.99$ and a std. deviation of 1.282. Questionnaire item (C28): When asked if respondents were happy with their trade union federation(s), a significant number 73.1% of the respondents were happy, 14.3% of the respondents were not happy, while 12.6% of the respondents were neutral. This yielded an overall response rate of 98% with an average mean of $\bar{x} = 3.98$ and a std. deviation of 1.274. The respondents' perceptions were closely clustered around the average mean distribution (see Table 2 below).

Table 2: DESCRIPTIVE ANALYSIS – TRADE UNION FEDERATION(s)

Research items	N	Mean	Std. Deviation
C27: I can talk to my trade union federation(s).	283	4.12	1.067
C26: I trust my trade union federation(s).	284	3.99	1.282
C28: I am happy with my trade union federation(s).	286	3.98	1.274

Source: (Statistical calculation from SPSS analysis: 2016)

Results and Interpretation

The main empirical results of this study contradicts the perception that the public and working class have lost trust and confidence in trade unions. In terms of the theoretical background, the empirical research findings indicate that a substantial number of the miners have full trust and confidence in their trade union federation pertaining to representation and bargaining council. The findings also suggest that majority of miners have an open dialogue with their trade unions (i.e. sharing and exchanging ideas, opinions, news, problems, etc.); and most importantly, they are happy.

Limitations and Future Research

This research study was limited to only one mining company – the Impala Platinum mine, which is part of Implats', and is situated 5 to 30 km north of the city of Rustenburg, in South Africa. The study did not include other mining companies. The study also focused on one occupational mining category (conventional stopping), and did not cover other occupational categories. Respondents may not have answered some questions as their level of literacy could have been a factor and even fear of retrenchment may have played a significant role. Although the study demonstrated internal validity, it needs to be extended to other mining companies and also to other occupational mining categories in order to further generalise its findings, as the scope of this study was limited to conventional stoping at Impala platinum in Rustenburg, South Africa.

PRACTICAL IMPLICATIONS

It is fundamental that the above-mentioned employment policies are complimentary to each other. For instance, with respect to labour legislation and regulation, as well as collective bargaining, it is imperative that all sectors adhere to employment policies that would improve the employer-employee relationship. It is essential to point out that, some of these employment policies may work in certain sectors, but not necessarily in all sectors (i.e. agricultural or farming, retail, hospitality, community health etc.). From a South African perspective, businesses have a tendency to underestimate employment policy processes. In terms of the Company Act, 2008, some of these businesses are not even registered and this is where exploitation of workers comes in – People being paid less than what is required from them (in terms of services rendered), working more than 8 hours a day, working under poor conditions, etc. Mine companies, trade union federations and the South African government should work towards creating better industrial relations (i.e. collective bargaining, employee relation policies, workplace policies and procedures etc.); that would improve the socio-economic issues (i.e. poor working and living conditions, poverty, inadequate remuneration etc.); that drive mineworkers to down tools. It is imperative that mining companies and trade union federations improve employee participation in decision making processes within the mining industry. This would indicate to miners that they are adding value and are considered an essential part of an organization, and not just seen as cost incurred. Trade unions federation(s) should continue to provide adequate voice and service to their members as they play a significant role in representation and bargaining council. Trade union federation(s) and mine management should consider including mining personnel in structuring flexible remuneration packages that would further encourage mineworkers to put more effort into their work. This would make mineworkers feel more appreciated and that they are part of an essential system that values its workforce. In addition, this would restrain industrial unrests within the mining industry.

REFERENCES

- Adcorp Employment Index (2013). Available from: <http://www.adcorp.co.za/Documents/Adcorp%20Employment%20Index%20-%20201305.pdf> [Accessed 9 September 2015].
- Antin, D. (2013). The South African Mining Sector: An Industry at a Crossroads. Available from: <http://www.oakbay.co.za/images/South%20African%20Mining%20Industry.pdf> [Accessed 13 March 2017].
- Barbeau, N. (2013). Unions losing public's trust. Available from: <http://www.iol.co.za/news/politics/unions-losing-publics-trust-1505168> [Accessed 22 May 2016].
- Bhoola, U. (2011). National Labour Law Profile: South Africa. Available from: http://www.ilo.org/ifpdial/information-resources/national-labour-law-profiles/WCMS_158919/lang-en/index.htm [Accessed 25 February 2015].
- Bhorat, H., Naidoo, K., & Yu, D. (2014). Trade Unions in an Emerging Economy: The Case of South Africa. Development Policy Research Unit. Available from: http://www.dpru.uct.ac.za/sites/default/files/image_tool/images/36/DPRU%20WP201402.pdf [Accessed 9 September 2015].
- Budeli, M. (2009). Workers' Rights to Freedom of Association and Trade Unionism in South Africa: An Historical Perspective. Available from: http://uir.unisa.ac.za/bitstream/handle/10500/3944/funda_v15_n2_a2.pdf [Accessed 24 February 2015].
- Congress of South African Trade Unions (2013). COSATU Booklet on the Campaign against HIV/AIDS. Available from: <http://www.cosatu.org.za/show.php?ID=1474> [Assessed 8 September 2013].
- Chamber of Mines of South Africa. Platinum in History. Available from: <http://www.chamberofmines.org.za/sa-mining/platinum> [Assessed 2 March 2017].
- Chaudhary, N., & Sharma, B. (2012). Impact of Employee on Performance (Productivity) In Private Organization. Electronic version, *International Journal Business of Trends and Technology*, 2(4), p. 29-35.
- Cronje, F., Reyneke, S., & Van Wyk, D. (2013). Local communities and health disaster management in the mining sector. *Journal of Disaster Risk Studies*, 5(2), 1-12.
- Dhliwayo, R. (2012). The rise or fall of trade unions in South Africa: The Marikana incident. Available from: <http://www.polity.org.za/article/the-rise-or-fall-of-trade-unions-in-south-africa-the-marikana-incident-2012-10-11> [Accessed 09 November 2015].
- Festus L., Kasongo A., Moses M., & Yu D. (2015). The South African labour market, 1995-2013. Economic Research Southern Africa (ERSA). Available from: https://www.econrsa.org/system/files/publications/working_papers/working_paper_493.pdf [Accessed 31 January 2017].
- Harmony Gold Mining Company Limited (2015). South African Mining Charter Compliance. Available from: <https://www.harmony.co.za/sustainability/mining-charter-compliance> [Accessed 15 March 2017].
- Harrison, P., & Zack, T. (2012). The power of mining: the fall of gold and rise of Johannesburg. *Journal of Contemporary African Studies*, 30(4), 551-570.
- Kowalik, G. (2007). Human Capital Review: Understanding Transformation in the Context of Employment Equity, Skills Development and B-BBEE. Available from: http://www.humancapitalreview.org/content/default.asp?Article_ID=993 [Accessed 19 June 2015].

Masia, U., & Pienaar, J. (2011). Unravelling safety compliance in the mining industry: examining the role of work stress, job insecurity, satisfaction and commitment as antecedents. *SA Journal of Industrial Psychology/SA Tydskrif vir Bedryfsielkunde*, 37(1), 1-10.

Mining Review Africa (2014). Effects of the mining strikes on the South African Economy. Available from: <http://www.miningreview.com/news/effects-of-the-mining-strikes-on-the-south-african-economy/> [Accessed 23 May 2017].

Mirrian, N. (2014). Mining Intelligence Database. Toyota and Ford halt output as strike bites. Available from: <http://www.bdlive.co.za/business/trade/2014/07/15/toyota-and-ford-halt-output-as-strike-bites> [Accessed 07 November 2014].

Mokoena, O.B. (2013). Lonmin Human Capital Overview: Human Capital Overview. Available from: https://www.lonmin.com/downloads/media_centre/news/press/2013/Human_Capital_Overview_-_FINAL_01072013.pdf [Accessed 16 September 2015].

Samuel, O.M., (2013). The mineworkers' unprocedural strike: setting the path for redefining collective bargaining practice in South Africa. *Journal of Contemporary Management*, 10, 239-258.

South African History Online (Apartheid Legislation). Available from: <http://www.sahistory.org.za/article/apartheid-legislation-1850s-1970s> [Accessed 24 February 2015].

The South African Institute of Race Relations (SAIRR): Billions lost due to strike. Available from: <http://www.iol.co.za/business-report/companies/sa-mines-lost-billions-during-strikes-1498824> [Accessed 11 April 2013].

Tansel, A., & Gazioglu, S. (2013). Management-Employee Relations, Firm Size and Job Satisfaction. IZA DP No. 7308. Available from: <http://ftp.iza.org/dp7308.pdf> [Accessed 17 September 2015].

Twala, C. (2014). The Marikana Massacre: A Historical Overview of the Labour Unrest in the Mining Sector in South Africa. *South African Peace and Security Studies*, 1(2), 61-67.

Ude, U., & Coker, M.A. (2012). Incentive Schemes, Employee Motivation and Productivity in Organizations in Nigeria: Analytical Linkages. *IOSR Journal of Business and Management (IOSRJBM)*, 1(4), 32-39.

Willemse, I., & Nyelisani, P. (2015). *Statistical Methods and Calculation Skills*. Fourth edition. Cape Town: Juta and Company (Pty) Ltd.

THE LEGAL SIDE OF TALENT: EXPLORING THE FACTORS AFFECTING THE EFFECTIVE MANAGEMENT OF DISPUTE RESOLUTIONS IN SELECTED SOUTH AFRICAN GOVERNMENT INSTITUTIONS

Kelebogile Makhuzeni and Nico Schutte
Global Innovative Forefront Talent Research Niche Area
North-West University, Mafikeng Campus
South Africa

ABSTRACT

The main objective of this study was to explore the factors affecting the effective management of dispute resolutions in South African Government Institutions. A qualitative research approach was followed with interviews conducted with different management levels (N=8) in selected government institutions. The findings showed that managers, supervisors and heads of institutions are not well equipped to handle dispute resolution issues in a manner that complies with set standards. The findings also showed that the level of education and maturity are the best tools to resolve conflicts at the workplace. Recommendations are made.

INTRODUCTION

Employment relations and work form the cornerstone of economic prosperity and quality of life for the people of not only South Africa but also the entire continent of Africa (Raligalia, 2014:71). Organisational leaders are accountable for creating a work environment that enables people to flourish and use mediation skills and interventions to reduce conflict-ridden situations (Van Gramberg, 2006:8-10). The obligation therefore resides with the employer to maintain discipline in the workplace (Mathiba, 2012).

At present, the South African labour scene is an area of contention as never before. Despite numerous recent transitions to democracy in Africa, poorly managed conflict continues to haunt the continent, and defy development initiatives and projects promoting good governance. Although critical interventions, specifically intended to go beyond the 'traditional' conflict management techniques of negotiation and mediation did take place, these never went the full distance. Many disciplinary actions are challenged in court as procedures are not fairly applied and according to legislative frameworks (Makhuzeni, Barkhuizen & Maubane, 2015). Moreover a lack of custom made procedures result in employers not being able to deal effectively with misconduct in the workplace (Mogotsi & Barkhuizen, 2016).

As a means of enforcing workplace discipline, dismissals should be considered as a sanction of last resort (Grogan, 2009). The Labour Relations Act Code of Good Practice is contained in Schedule 8 and provides guidelines to the interpretation and application of the statutes regarding which they are issued (Grogan, 2009). Employers must take account of the code when managing discipline and incapacity cases. The key principle in this code is that employers and employees should treat one another with mutual respect (Nel, Swanepoel, Erasmus, Tsabadi & Katz, 2002). Organisations should therefore set a standard of performance and conduct reinforced by

organisational rules. Grievance procedures are used for considering problems or concerns that employees wish to raise with their employers (Davies, 2011).

McGrane, Wilson and Commack (2004) have exhibited that communication skills in dispute resolution are vital in grievance management. These skills include skills in scanning the workplace context, personal attributes, managing emotions, preparing for one-to-one resolution, making a practical approach, maintaining a people-oriented approach, problem-solving skills and concluding power. Management training in conflict resolution can give supervisors insight into the dynamics and nature of employees' grievances ((Bohlander & Snell, 2004). As mentioned by Mondy and Noe (2005) labour relations problems can escalate when managers are not equipped with the skills and knowledge to handle initial grievances.

In sum, the employment relationship brings a human element to the workplace environment, which include issues such as personal problems, complaints against supervisors or colleagues and or dissatisfaction regarding working conditions. The right to speak out against unacceptable treatment received from supervisors and lodging complaints regarding employment related issues, become part of workplace democracy. In order to assist both the employer and the employee in managing this part of the employment relationship, it is imperative that employers establish a grievance procedure which is fair, consistent and equitable for employees.

Moreover the timeous resolution of complaints is an important element in developing a productive and harmonious work environment for the government. Researchers have found that departments, in general, are unable to resolve complaints within the prescribed time frame. Furthermore, the arrogance of employees who are aggrieved in the workplace may hurt their performance. This situation is worsened by the ineffectual handling of such dissatisfactions, resulting in delays in the finalisation of cases.

Therefore the main objective of this study was to explore the factors affecting the effective management of dispute resolutions in South African Government Institutions. The foundation for the sound management of claims lies in the implementation of appropriate procedures or tools for dealing with complaints. Of significance is that the grievance procedure should encourage the prompt resolution of complaints.

The elements of an effective grievance procedure may vary from one context to another, but should include at least the following:

- In the first instance, Batho Pele Principles should apply to all. A transparent “*receipt and registration system*” should be in place.
- Grievances should be evaluated to identify the issues and distress raised up in grievances by the aggrieved. This process should be followed by collecting evidence and finding the ideas of other interested parties. A strategy should be developed to identify whether and how the matters might be determined.
- Imperative to the grievance procedure, is the aptitude to solve the problem that gave rise to the complaint. In trying to resolve a complaint, it is important that the process that is followed comply with established principles and standards.
- Communication is one of the most important fundamentals as it strengthens the grievance resolution process. Feedback should continuously be provided to the aggrieved party to ensure that he or she is updated on the progress made in trying to resolve the complaint.

For a grievance procedure to be effective, it needs to be sufficiently communicated throughout an organisation on a constant basis. If employees are not even cognisant of the reality of the grievance actions, they would most probably turn towards other apparatuses known to them. In the end, the grievance procedure should assist departments in creating a harmonious work environment for the benefit of all employees.

RESEARCH DESIGN

Research approach

The nature of the study also necessitated a qualitative research approach. Qualitative research focuses on the depth of knowledge rather than the quality of understanding (Creswell, 2012). Qualitative exploratory research was deemed most appropriate to uncover the factors that could contribute to the management of dispute resolution in government institutions. This research followed a case study strategy as it was considered to be the best suited to the researcher's goal to explore a current phenomenon in reality (Creswell, 2014). A qualitative case study approach in this research falls within the interpretive or constructivist paradigm (Yin, 2012). In this instance, the ontological belief is that reality is local and specifically constructed.

Sampling

The sample was selected on a purposive convenience basis (Chrisler & McCreary, 2010). The target population comprised seven senior managers and employees dealing with management of dispute resolution (N=08) in South African government institutions and one union representative that was not an employee of government but was versed with Labour Relations good-practices. For practical reasons, the sample population had to be narrowed down. The decision to use the non-probability sample technique (Leedy, 1997) was motivated by the nature of the study which required people with in-depth knowledge and experience with regard to the policy around which the interview questions were based. It was deemed appropriate to use senior employees and employees dealing with management of dispute resolution. It was contended that such decision would add value to the quality and outcomes of the study. Table 1 below shows the demographic delineation:

Table 1: Sample Demographics

Participants	Gender	Race	Qualification	Job Level
1	Male	Black/African	Master's	Senior Manager
2	Male	Black/African	Master's	Middle Manager
3	Female	Black/African	Master's	Middle Manager
4	Male	Black/African	Doctorate	Senior Manager
5	Male	Black/African	Honours	Senior Manager
6	Male	Black/African	Honours	Senior Manager
7	Male	Black/African	Honours	LR. Manager
8	Male	Black/African	BA Degree	Union Representative

As can be seen from the table above, the majority of the participants were male, making up 87, 5% (seven participants of the sample), while the female participants constitute 12, 5% (one participant) of the selected sample. The demographic distribution of race was constituted of black/African people in the sample, with 100% (8 participants). About 75% participants (four individuals) in the sample demonstrated being senior managers and some had Master's, Doctoral and Honour Degrees as exhibited in the table above. The distribution in terms of managerial level as depicted in Table 3.1 showed 25% (two participants) to be in the middle tier of management and another 25% were officers. The table also shows that only one out of seven participants was female. It is also shown that one out of seven participants represented middle management female participants who had 12 years of service in the aggregate sample.

Data collection method

Data was collected by means of semi-structured interviews. Researchers usually have a list of themes to be covered that can vary between interviews (Welman, Kruger & Mitchell, 2010). Terblanche, Durrheim and Painter (2006) state that conducting an interview is a more natural form of interacting with people than having them fill out a questionnaire, do a test, or perform some experimental task. Therefore, it fits well with the interpretive approach to research. It gives us an opportunity to get to know people quite intimately so that we can understand how they think and feel.

Data analysis

In accordance with Bernard and Ryan (2010), a transcription was used, whereby the audio recorded responses of the participants were converted into text in a Word document. Thematic analysis was employed in this study to uncover the associations that existed across the phenomena and how these associations related with the aggregate cultural setting of this research could be determined (Leech & Onwuegbuzie, 2008). The researcher attached mnemonic labels to each theme and sub-theme through open coding to provide a description of the newly discovered phenomena as well as inclusion criteria. The generated codes were then refined through axial coding, and the labels and their descriptions were supported by verbatim quotes from the interview responses and also compared with literature and similar studies in order to determine the validity of the data and to ensure that the main research question was appropriately addressed (Leech & Onwuegbuzie, 2008).

FINDINGS

Themes were clustered into the following areas: Playing an active role in enhancing management of dispute resolution, education as a key role player, educated in handling and resolving conflict in the workplace, responses relating to a possible conflict with a supervisor and settling conflict between two individuals.

Theme: Playing an active role in enhancing management of dispute resolution

The sub-theme above discusses a way in which management can play an active role in enhancing dispute resolution in government institutions. Some of the quotes by participants include:

The management must stop applying the policies selectively, they must uphold the key principles of the policies and fairness. (P1, male, black/African, senior manager, Masters degree).

Another participant mentioned:

Appoint suitable people to deliver on the work. Setting up a dispute resolution plan with timeframes to dealing with cases. (P4, male, black/African, senior manager, Doctoral degree).

Conflict is endemic to human society, among individuals and groups and it is important to manage it. Conflict can be dangerous, it carries the possibility of producing creative cooperation in a win-win solution. The key to this is for participants to engage as joint problem solvers, seeking to resolve the dispute and to try to enlarge the pie rather than act as adversaries and aggravating the situation.

Sub-Theme: Education as a key role player

Responses relating to education as a key role player in minimising conflict at the workplace. A number of quotes taken from the responses of various participants in support of their perceptions are presented below:

Yes, because I believe that policies are less ready and understood in the workplace. (P1, male, black/African, senior manager, masters degree).

Participant 7 said:

Yes it is true that education plays a major role. Capacitating managers on management of discipline and possible dispute resolution process can minimize conflict in the work place. (P7, male, black/African, BA degree, senior Labour Relations).

It seems that employers are doing very little to resolve workplace conflict. In the opinion of the researcher, most managers aren't well-versed with effectively handling conflict. Many managers ignore conflict. Instead of ignoring conflict, they need to know how to address such situations and help employees regain focus.

Sub-Theme: Educated in handling and resolving conflict in the workplace

Responses relating to possibility of everyone been educated enough to handle and resolve conflict in the workplace. The participants were in agreement that everyone was not educated enough to handle and resolve conflict in the workplace. Most of the quotes included:

No – it is important to introduce education on this subject. (P2, male, black/African, middle manager, masters degree).

And

No, that's why is important we should make sure people are qualified for their jobs which will result in one taking interest in their education to towards Labour Relations. (P5, male, black/African, honours degree, senior manager).

Sub-Theme: Responses relating to a possible conflict with a supervisor

This sub-theme relates to whether an employee had a conflict with a supervisor. Most participants mentioned that they never had any conflict with their supervisor while few had and one of them mentioned that conflict was an inherent and integral part of their daily work.

Some of the quotes include:

Yes, unfortunately it was not resolved whereas there are policies are in place. Seniors believe that they are above policies. (P1, male, black/African, senior manager, masters degree).

Participant 7 mentioned:

Like I said earlier, conflict is an inherent and integral part of our daily work life so it will be up normal if say I never had a conflict with my superiors. At times conflict comes from a disagreement with my superior and we deal with the issues until I fully understand and the conflict is dealt with. (P7, male, black/African, BA degree, senior Labour Relations).

The researchers' experience is that two parties typically quarrel when each one refuses to consider the other's perspective. Regardless of individual perspectives, managers are responsible for setting policy and subordinates are responsible for executing it.

Sub-theme: settling conflict between two individuals

This sub-theme relates to an instance where one had to settle a conflict between two individuals at the workplace. As mentioned by some of the participants:

I have not been in that situation before – but should I find myself in the situation I will follow the procedures and implement the policy prescripts other than emotional handling of the dispute. (P2, male, black/African, middle manager, masters degree).

Another participant mentioned that:

I noted the conflict, listened to both parties and considered the merits thereof. Checked the merits against prescripts and the recommended actions, engaged both parties and finalise the matter by pointing out their areas of wrong/limitations as well as areas in which they acted correctly. Passed sanctions and formulated way-forward to prevent repeat. (P4, male, black/African, Doctoral degree, senior manager).

Participant 6 made a crucial point, in saying:

None. Winning the trust of colleagues is crucial; they both have to belief and trust you. Listen attentively to both pass judgment and apportion blame. (P6, male, black/African, honours degree, senior manager).

DISCUSSION

The primary objective of this study was to explore the factors that affected the effective management of dispute resolutions in South African Government Institutions. More especially, this research aimed at exploring the facilitating factors that enhanced management of dispute resolution in selected South African Government Institutions.

The findings have revealed that sometimes conflicts come as the result of perception of some people about others. If in an organisation a particular group perceive themselves to better than others, this may lead to conflict. Regardless of individual perspectives, managers are responsible for setting policy and subordinates are responsible for executing it. Thus, the level of education and maturity will be the best tool to resolve conflict in the work place. In short, not everyone is educated to resolve conflict.

This research had some limitations. A qualitative research approach was followed with the sample of participants limited to those who understood and handled Labour Relation practices. The limited research available made it difficult to interpret the findings. More research on exploring the facilitating factors that enhance management of dispute resolution in South Africa is needed to advance the available knowledge base. For future reference this study can further be extended to everyone in government institutions as it will assist in terms of helping the institutions to solve their problems and capacitate those that do not know Labour Relations practices.

From a practical perspective, the following recommendations are made. Government Institutions often have a wealth of information at their disposal in the areas of Human Resources and Labour Relations which could guide important strategic management decisions. In the absence of awareness of the significance of the information, much of its value is lost. Likewise, the monitoring and evaluation approach to management of dispute resolution information is rather seen as an irritant to them. In promoting labour peace, government institutional Human Resources and Labour Relations components should ensure that employees are familiar with their rights and obligations and that managers and supervisors are familiar with and skilled in carrying out their responsibilities in respect of the management of dispute resolution.

From the above analysis, it is evident that a grievance procedure that provides a simple, transparent and timely manner in which dissatisfactions of employees are addressed, is a recipe for success in any organisation. However, the most important ingredient in this process is the commitment of all stakeholders. In order for management of dispute resolution to be effective, all employees, but specifically managers, should be standard-bearers of the process. This further means that there should be an effective communication procedure in place and all employees should receive regular training on the grievance procedure.

REFERENCES

- Bohlander, G., & Snell, S. (2004). *Managing Human Resource*. (13th ed.). Thomson: South-Western.
- Chrisler J.C. & McCreary, D.R. (2010). *Handbook of gender research in Psychology*. London: Springer.
- Cresswell, J.W. (2012). *Qualitative inquiry and research design: choosing among five approaches*. Thousand Oaks, California: SAGE Publications.
- Cresswell, J. W. (2014). *Research Design: Qualitative, Quantitative, and Mixed Methods Approaches* (4th Ed.). Thousand Oaks, California: SAGE Publications, Inc.
- Davies, A. (2011). *Workplace Law Handbook 2011: Employment Law and Human Resources*. Workplace Law Group Ltd., Cambridge, UK.
- Grogan, J. 2009. *Workplace law* (10th Ed.). Cape Town: Juta & Co. Ltd.
- Leedy, P.D. (2007). *Practical research planning and design*. (6th ed.). New Jersey: Prentice-Hall.
- Makhuzeni, K.C., Barkhuizen, E.N., & Maubane, D. (2015). Perceived effects of precautionary suspensions on service delivery in a South African provincial government department, *Journal of Public Administration*, 50, 1, 644-657.
- Mathiba, M.K. 2012. *The jurisdictional conflict between labour and civil courts in labour matters: A critical discussion on the prevention of forum shopping*. Unpublished Masters dissertation. Pretoria: University of South Africa.
- McGrane, F., Wilson, J., & Cammock, T. (2005). Leading employees in one-to-one dispute resolution. *Leadership and Organization Development Journal*, 26(4), 263-279.
- Mogotsi, M., & Barkhuizen, E.N. (2016). Management perceptions on the effectiveness of disciplinary measures in a provincial government department. Paper presented at the 26th International Academic Conference, Istanbul, Turkey.
- Mondy, R.W., & Noe, R.M. (2005). *Human Resource Management*. (9th ed.). New Jersey: Pearson Education Inc.
- Nel, P. S., Swanepoel, B. J., Erasmus, B. J. Tsabadi, M. J. & Katz, M. A. 2002. *South African Employment Relations*. Durban: Butterworths
- Raligalia, K.H. 2014. A reflection on the duty of mutual trust and confidence: Off-duty misconduct in the case of *Biggar v City of Johannesburg* revisited. *South African Journal of Labour Relations Management*, 38(2):70-77.
- Van Gramberg, B. (2006). *Managing workplace conflict: alternative dispute resolution in Australia*. Sydney: The Federation Press.
- Yin, R. K. (2012). *Applications of case study research* (3rd ed.). Thousand Oaks, CA: SAGE Publications.

ASSESSING THE IMPLEMENTATION OF CORPORATE SOCIAL RESPONSIBILITY PRACTICES: INSIGHTS FROM CAMDEN AND GROOTVLEI POWER STATIONS

Rankhumise Edward Malatse
Tshwane University of Technology, South Africa

Botshe Andrew Ramabele
University of South Africa, South Africa

ABSTRACT

A study was conducted among the community members from Balfour and Ermelo and Management regarding ESKOM Corporate Social Responsibility practices by the selected power stations, namely Grootvlei and Camden. A qualitative approach was used and data were collected focus groups among community representatives and management. Data was analysed using Tech's data reduction technique of open data coding. The findings indicate that some of the community members are aware of the CSR practices and this has resulted in some of the communities revolting against the power stations. Mixed feelings were detected in most of the identified themes. These findings were characterised by some of the community members indicating that they are aware of the CSR initiatives implemented whilst others hold a different view on the same matter. Concluding remarks suggest there is lack of commitment and communication from the power stations management in the implementation of CSR practices. Budgetary constraints were identified as an impediment for CSR.

Keywords: Community development, corporate social responsibility, Eskom, Livelihood.

INTRODUCTION

According to Nadaf and Nadaf (2014, p.52) corporate social responsibility (CSR) main purpose is to embrace responsibility for the company's actions and encourage a positive impact through its activities on the environment, consumers, employees, communities, stakeholders and other members of the society. This notion suggests that whatever the companies are doing within their areas of operations, their actions should be more positive. CSR is an integral component of managing businesses and this notion has received much attention worldwide. According to Mousiolis and Zaridis (2014, p.634) attest that CSR relates to a business approach that views respect of ethics, people, communities and the environment, as an integral strategy that improves the compete advantage of the of a firm's position in the market. It is thus notable that companies should embrace CSR in their strategic priorities. CSR can be viewed in terms of corporate responsibility, but it further focuses on the obligations a company or a firm has to the community and the environment al in which it operates.

According to Varadarajan and Kaul (2017) emphasize the notion that doing well by doing good, which in essence this means that the firms for-profit firms should strive to benefit society by contributing towards the alleviation of specific social problems and benefit the firm by enhancing its performance that is in terms of reputation, financial performance marketing performance and goodwill among stakeholders. Notably most of these companies have fewer resources to implement CSR, as some of them are of the view that they see this as a luxury and as such they concentrate on the core business activities which is profit making. Contrary to this, other

scholars such as Rhou, Singal and Koh (2016) believe that CSR activities could assist companies to build positive brand image and reputation which could lead to competitive edge in the market.

The society today is faced with major societal challenges characterised by unemployment, lack of opportunities that could improve their livelihood and lack of facilities such as libraries. In this respect, the society expects that companies operating within their environments should contribute in making life better for such society. The aspects of corporate social responsibility, corporate social investment and philanthropic activities, has to be implemented to improve the lives of all South Africans. This approach could enhance and promote social commitment of businesses and the entire nation undertakes the challenge to support sustainable economic development. The implications of this approach means regular and active involvement and communication of business with the community to understand their needs and challenges. The variety of social needs in South Africa in areas such as education, healthcare, job creation, and entrepreneurial development offer a wide spectrum in which businesses can intervene by utilizing CSR initiatives (Busacca, 2013:p.1). Beyond solving apparent social issues, CSR initiatives aim to empower local individuals to contribute to their own communities' economic growth and development.

LITERATURE REVIEW

Eskom is South Africa's primary electricity supplier and is wholly owned by the South African government and known as state owned enterprises (SOE's). Eskom generates approximately 95% of the electricity used in South Africa, with more than 83% of households having access to electricity and more than 40% of the electricity used in Africa. It operates 27 power stations capacities differentiated as follows: 13 coal-fired, 4 open cycle gas turbine(OCGT), 6 hydroelectric, 2 pumped storage scheme, 1 wind energy farm and 1 nuclear power station (Eskom Annual Report, 2008). Eskom is the largest producer of electricity in Africa, and among the top seven utilities in the world in terms of generation of capacity and among the top nine in terms of sale (Integrated Report, 2013).

Eskom operates a number of power stations, including Camden and Grootvlei which were also returned to service to meet the rising electricity demand in South Africa. The utility is nine years into a major capacity expansion programme that will deliver additional power stations and major power lines to meet the rising electricity demand, with a total budgeted expenditure of over R340 billion (excluding capitalized borrowing costs) to 2019 (Integrated Report, 2013).

CSR initiatives are very important in the context of corporate ethics. There are several findings that have caught the attention of CSR practitioners and scholars. These include studies which suggested that CSR activities do provide an "insurance-like" protection when negative and adverse events happen (Godfrey, Merrill & Hansen, 2009, p.425-445). Therefore, in order to pursue sustainable development, and achieve a good reputation in a fiercely competitive market, more and more corporations are publishing their CSR disclosures and CSR reports. Business is facing growing pressure and demands from society to become part of the solution to these problems and particularly the problems of sustainable jobs, poverty alleviation, education and HIV/AIDS interventions.

South Africa is faced with many challenges such as unemployment, homelessness and poverty has become more pressing. The South African government has made it one of its priorities to alleviate poverty and destitution among its people and to bring sustainable development among the society (Gradl & Knobloch, 2010; Sekwati, Hirchowitz & Orkin, as cited in Marais, 2001: p.23). However, it is evident that this has not materialised and these aspirations remain far from being met, hence it is imperative to conduct the study on this aspect.

In supporting the above articulation, Evans cited in Karlsson and Lindqvist (2012, p.34) argues that CSR will always be part of South African businesses. He further explains that unemployment rate in South Africa is very high at 25% and the unemployment youth rate at 39%. He claims that poverty in South Africa is very evident and everyone is terrified of what will happen next if something is not done to turn the situation around.

Masete (2011) explains that it is not known how integrated Eskom's socio-economic development projects are progressing in terms of addressing poverty and unemployment. He further asserts that corporate investment practitioners including corporate social responsibility managers should ensure that corporate social responsibility addresses the needs of disadvantaged communities where they are operating. These needs include among others; alleviating poverty and unemployment. It is also notable that CSI programmes are put in the hands of Eskom at National level and not where Eskom physically conducts business via CSI Managers and other stakeholders including the community. It is thus notable that business can contribute to CSI programmes at different level (Masete, 2011; Shongwe, 2008).

It has become a priority for most South African businesses to implement policies and strategies to manage and minimize social problems within the communities they conduct business. It is important to determine the level of commitment displayed by top management of the business in terms of its stakeholder theory in addressing the CSR issues like unemployment, lack of education and poverty (Mariri & Chipunza, 2011, p.98). Despite the return to service of previously mothballed power stations, the major problem identified is that there is still *high unemployment rate within the Ermelo and Balfour* communities. Based on the above articulations, the problem statement can be cited as: "Is there a lack of involvement of the Grootvlei and Camden power station's management in performing CSR practices to improve livelihood of the communities around these two power stations"

RESEARCH METHODOLOGY

Research approach

The design of this study was qualitative and *exploratory* in nature. It was expected that the exploratory approach in this instance, would provide the opportunity to unravel the nature of the participants' experiences and perspectives of CSR practices. Specifically, the promise of exploratory research is to obtain a richer understanding of the experiences relating to the challenges and success of the implementation of CSR practices in the selected power stations, namely, Camden and Grootvlei. To implement this, inductive approach was applied. This approach rely more on the use of qualitative data collection methods in order to gain a deep understanding of the factors and nature of the main issues or research problem.

The population of the study consisted of power station management members and community members. Purposive sampling was used and this is a type of nonprobability sampling in which the units to be observed are selected on the basis of the researcher's judgement and with the understanding that they will add value to the study. In this paper, the researchers investigated the views of the communities and management of Camden and Grootvlei power stations as regards to the contribution to the phenomenon of corporate social responsibility. The primary data was collected by means of focus groups in order to gather rich and raw information and to interact with the participants (Creswell, 2009). The researchers took field notes and also used audio tape to ensure that accurate data is collected.

Trustworthiness

In ensuring that this study was valid and reliable, the researchers followed the trustworthiness model of Lincoln and Guba (1985). The elements that were followed to ensure trustworthiness included among included credibility, transferability, dependability and confirmability. Trustworthiness was achieved by prolonged engagement, triangulation, purposive sampling, peer debriefing, and by using an independent coder (Creswell, 2009).

Data analysis

The field notes and audio taped interviews were transcribed verbatim by the researcher. In ensuring that transcription was done accurately, audiotapes were listened to once and then listened to a second time. This assisted in ensuring that accurate capturing of the data is done. The field notes were then read to understand the data properly and to get a sense of the whole using Tesch's data technique of open-coding. Data were analyzed through Tech's data reduction method by following the prescribed eight (8) steps namely, (i) get a sense of the whole by reading all the transcripts carefully; (ii) pick one interview and go through it without thinking of the substance of the information but its underlying meaning; (iii) when all the interviews have been completed, make a list of all topics; (iv) take the list and go back to the data and abbreviate codes; (v) find the most descriptive wording for your topics as codes and turn them into codes; (vi) make a final decision on the abbreviation for each category and alphabetize these codes; (vii) assemble the data material belonging to each category in one place and perform a preliminary analysis and (viii) in this last step, if necessary, recode your existing data.

After the data was completed, the researchers and co-coders met to discuss the analysis and agreed on the specific significant emerging themes.

DISCUSSION

The findings of this paper will be presented in the following order; sample realisation, research findings and discussion.

Sample realisation

The participants in this research consisted of Camden's management committee members (n=6), Grootvlei management committee members (n=4), Ermelo community members (n=4) and Balfour community (n=2). These participants provided valuable information regarding the CSR practices as implemented by the two selected power stations. For the purpose of this paper, the researchers will first present *community cases* so that there is a clear understanding of what the surrounding communities had to say about the two power stations. The second part of the presentation will cover the *Management committee* of the two selected power stations.

The discussion of the findings is organized in accordance with the main themes that emerged during the analyses stage of the community participants' responses. The participants in this specific study mentioned a generally interesting and specifically an important account of their experiences and challenges that relates to the CSR practices at the two selected power stations.

Community findings

Through the analysis of data from the community members, the following themes emerged; awareness of the initiatives by Eskom, contributions made by Eskom, lack of commitment and lack of communication.

Awareness of the initiatives by Eskom

The findings indicate that there are few community members who seem to be aware and knowledgeable of the CSR initiatives. The findings also indicate that those who are aware of these initiatives actually benefitted from the CSR programmes. Furthermore, there are still community members who will like to know more about Eskom-Camden initiatives. They highlighted that there was no information sharing within Eskom-Camden and community although the latter is the best tool to improve relationship. The finding is contrary to what Balfour community had said that they are aware of the initiatives implemented by their power station.

The response below is what the respondents had to say:

“ ... I am not aware of any initiatives by Eskom.

I don't think there are donations made by Camden, I am not sure. However, if there are any, I don't think they make any impact. We do participate on all structures and no information or nothing has ever been mentioned regarding contributions...”

Notably, most of the respondents were not aware of initiatives and this could be as a result of lack of awareness due to lack of information sharing. The researcher believes that a reasonable deduction would be that there is ineffective communication between the Management and the community regarding available Eskom-Camden CSR initiatives.

Contribution made by Eskom

The responses from the participants regarding their perceptions about the contributions resulted in having mixed perceptions about Eskom's contribution towards the communities. Respondents from Ermelo gave more negative responses while respondents from Balfour gave a more positive. This could be attributed to the fact that Ermelo community responded that they were not aware of Eskom initiatives.

I am not sure if people were promised jobs, obviously they would have expectations especially when a company comes to your area and build such a big structure. We can count how many people have been developed in the positions, nothing so far. The social development policy states that 60% of local managers in the organisation current it's just one person. It is something that has never happened, the expectations were high, and people start to give up, because there is nothing, employment wise and business wise (Ermelo community)

My feeling is that a couple of companies including their contractors can learn a thing or two from Grootvlei how it handles community things and how management is able to come down to engage with the community. Grootvlei is currently doing well and engaging more with community; it can only improve for better. Eskom being one of the few companies operating in Dipaleseng has really sustained the community. A great impact, the learners don't have to go home to relieve themselves anymore, the school does not have to organize transport to get learners to another school for science project because Eskom has donated Lab equipment and the learners are no longer over crowded because there are two extra class rooms.(Balfour)

Participants provided contradictory views on the contributions made by the two power stations. It emerged that Balfour community are happy about the contributions made by their power station. Ermelo community holds negative perceptions on how the Camden power station is contributing to the welfare of the community.

Lack of commitment

Participants more especially from Ermelo indicated that lack of communication emerged as one of the factors that inhibit successful implementation of SCD. The community reiterated the need for someone who is committed to address their issues. There was also a genuine commitment of all parties to the partnership process. The community believes that their issues are not being addressed and they are in position to protest against Camden at any time.

“ ... We never engage with Camden – we were supposed to have BU forum meeting with all businesses; we never met. That forum is organised by municipality, they call companies and businesses, issue of unemployment–municipality normally invited people – normally they invite Camden personnel – they seem to fear, might fear some of the things, not sure why because they also part of this community. We want someone who will commit at these meetings and needs deliverables...”

Lack of communication

Lack of communication emerged as a factor that inhibits successful implementation of ESKOM CSR initiatives. The community is adamant that the relations should be approached from a strategic point of view, because they hold the company's social license to operate and they can protest at any time. They need to be aware of what is coming and available for them. They further believe that if information is shared on the local newspapers, road shows and not on the internet, then they will be in a better position to equip them with knowledge regarding available jobs and tender process. The responses from Balfour were positive regarding the commitment of Grootvlei Management in addressing their social challenges

Management committee findings

The findings from the two power station management suggest that there are programmes available to sustain the community and improve their livelihood. Through the analysis, the following themes emerged, namely; training and development, education, lack of engagement and budgetary constraints

Training and development

From the analysis, it is evident that the stations do have plans in place to develop and uplift the community in relation to training and development. It is noted from the quotes that there is an intention to ameliorate poverty within the community.

There was no effort to visit community; we have since changed that because we have a couple of exhibitions, awareness and education. We follow different streams now, twice in a year, commercial guys will have seminars at the community halls/public forums, career: educate community on how to get business into Eskom business. For career and education as well, we visit Gert Sibande colleges, distribute pamphlet at high schools where we educate the youth regarding bursaries and learnership programs and so forth. Those looking for employment there is also a different forums where these issues are discussed, educate on how employment is being sourced.

It can be deduced that both management committees of the power stations do have plans in place to assist the community to improve training and development. As aforementioned, the management also stated that there is a vision and strategy in place. The probable deduction is that there is ineffective communication and engagement with the community to ensure awareness of available programs with regards to training and development.

Creation of job opportunities

The participants indicated that they are doing their utmost best to enhance the livelihood of the community within their areas of jurisdiction. They highlighted that they alleviate poverty, mobilize opportunities with their stakeholders and this include among others contractors given tenders by the power stations. The following is what the participants had articulated.

"...CSR is not a mandate, but a best practice – some mandates are constitutional, the current CSR mandates are not constitutional. We alleviate poverty, by offering employment and are not employment agencies, but make employment opportunities available so that they participate in the economy. If jobs are not available, then they are not available. However we do ensure that people takes part in the economy..."

"...Notwithstanding the fact that we are technology driven industry, procure services that are not technology driven: normal grass cutting, cleaning, woman to clean; a lot can be done to support the community. Grass cutting, cleaning – a group of people – supply of stationery – transportation – This contributes largely to the community..."

“...There is a data base created at Department of labour, all low level skilled people to submit their CV’s so that they can be contacted when opportunities arise from contractors...”Business case of Camden: operates with Contractors– Camden have made it clear and have partnered with department of labour, when opportunities arise at Camden: first try local community for low skilled labour when opportunity arises – hence all partners are advised that you shall source at Ermelo, unless the skills are not available at Ermelo. The following were responses from Grootvlei Management:

“...Even Balfour is one of the most ill skilled communities; education level is very poor, low skilled. We have started our initiative, we encourage and enforcing contractors to train people as welders, riggers, work on heights or whatever the skill so that the time the contract expires, they have something they have developed themselves and have certificates. From the station we are taking students to schools to curb low skills, this year we take 6 students to Varsity, the station budget. The budget is limited only to books and fees, 60% English, math’s and Physics. We still push with further studies as well as we have a student at Wits doing Chemical engineering...”

It emerged that training and development is one of the major components of CSR in uplifting the skills of the community. The management felt strongly that the development of the community especially the poor as critical. They highlighted that there are plans and initiatives in place to address low skills at the communities. They highlighted that they have within their own station budget, provision to sponsor some of the community members to Universities. This is a phenomenal finding at Grootvlei power station and Camden.

Education

The participants indicated that there are low-level skills within the two communities of Ermelo and Balfour. This can be attributed to why there are few community occupying higher positions at the power stations. However, there seem to be plans in place to improve quality of education.

“...First time at Camden, never been established before, encourage the learners to complete their Grade 12 with good results. Assist in tackling grade 9’s so that they know what job contents of their career are all about. Ensure their subjects are in line with their career path. It’s important that when you are young you are aware of what job contents require. It has also been highlighted as gap that most people don’t know what subjects and training should pursue in order to be employable.

“...When we have bursaries comes with the stream of HR- most markets are around Ermelo, our preferences; it’s within our jurisdiction - to advertise at schools about bursaries. Skills plan community surrounding areas encourage the kids to follow certain careers. Our skills retention and plan looks at surrounding community, we look at the profiles at Ermelo and advice schools the right stream in case they want to stay and work around their area

The Grootvlei Young Professionals program is initiated in a drive to get the Young Professionals to be more involved and hands-on in various aspects of the Business Unit of taking the BU to newer heights. The program is also intended to advance the career aspirations of all motivated and driven Young Professionals in the station...”

It can be deduced that there is definitely plans in place to improve the skills of local community to prepare them for future available positions and opportunities within Camden. The findings reflect that there is definitely shortage of skills and qualified people within the community. It is evident from the findings that Grootvlei power station has indeed done a lot on education to ensure sustainable community development within Balfour area.

Lack of engagement

Camden management confirmed that there are indeed factors which might be contributing to slow implementation of CSR issues. Although there is a strategy in place to focus on community developmental issues, it emerged that there is lack of commitment and engagement from management. The management is not

proactive but rather reactive to resolve community challenges and that led to many protests. It came out clearly from the interviews that management engages less with the community. It is imperative for management to bridge existing gaps with the community by means of continuous communication. The following quotes are responses from management of the two the power stations:

“... It is when there are no proper engagement between Power Station management and community members these will definitely lead to protests...”We only informed them of possible tenders that might be coming. We have enticed them this is what is available or coming, if you adapt, be ready in case opportunities come up, but we always leave them hanging...”

“... It’s an area we don’t do well, we engage less. We do target schools but don’t do much on community issues/ concerns at meetings. There is committee onsite ran by HR and communications department they deal with community concerns, but the approach it’s more of reactive meetings that being proactive because they only engage when community is upset, its Eskom , community and department of labour...”

From the analysis, it emerged that management of the two power stations are not engaging the communities fully. The probable solution to this challenge is to continuously engage with the community to understand their needs and issues at hand. It is inevitable not to wait until there is a community protest before responding and in this regard damage would have already been done.

Budgetary constraints

The participants indicated that there are financial challenges within the power stations. They alluded that some projects have been put on hold and no execution as they have been stopped due to financial constraints. They acknowledged that their budgets have been cut and focus is more on maintenance to ‘keep the lights on. The following is what the participants had to say:

“...There is no budget locally, it has been taken away. Our mandate is to look at applications, decide whether we grant or not, final approval comes from ESDEF. Our budget line for donations is very minimal...”

“...As Young Professionals, we are not being given enough budget and opportunity to run the community projects and develop their capacity. No. There was a donation budget of about R60000 per year, not sure if it’s still there. If we want to run projects, we ask management and seek for donations. Young Professionals don’t have their own allocated budgets; we do have brilliant ideas, young fresh minds, and full of energy...”

It could therefore be deduced that there are plans and ideas on the ground, but there are challenges in terms of the budget. It is evident that both the management committees of the power stations have budgetary constraints to fulfil the required CSR practices within their jurisdictions.

LIMITATIONS OF THE RESEARCH

This study like all other studies has several limitations. First, the study only focused on two power stations and therefore, the findings cannot be claimed beyond the two research sites. Second, it could be interesting to broaden the study to other power stations in South Africa so as to allow generalisability of the findings. Third, the study was only qualitative and bringing quantitative approach could have helped.

MANAGERIAL IMPLICATIONS

The findings have implications for the management for instance; the community of Balfour is more positive about the contribution made by the power station and on the other side there is negative perception about Camden power station. Therefore, the Camden management should introspect of what they are doing wrong in

their environment. These findings can enable management of make introspection of their activities so that they improve on the aspects that they are not performing well. The findings could provide an understanding and defining who and what your community is and reflect its implications on operations. The positive impact on the community is likely going to create a positive image and reputation for the business. The research has attempted to raise the impact of the implementation of CSR on the strategic forefront of the business or the power stations. The results as such will enable the power stations to better define their CSR practices. Finally, this research could enhance communication between community and the power stations which could improve partnership.

CONCLUSIONS

In this paper, we investigated the involvement of power station management in performing CSR practices to improve livelihood of the communities in their area of operations. Based on the findings, it could be concluded that some of the community examined are of the view that they are not aware of the Eskom CSR initiatives. Lack of communication and commitment are seen as factors that inhibit the sustainable community development in relation to CSR. It could further be concluded that the two power stations are embarking on educational programmes to up skill the community. Both power stations indicated that they are unable to support the communities around their operations due to budgetary constraints. It is also found that there is lack of engagement between the community and the power stations and this creates some misunderstandings between the power stations and the community. Finally, it is notable that there is disbelief about the some of the contributions made by the power stations. In order to avoid the difficulties of building good relationships with the community, the power station needs to establish a Communication department with a dedicated community relations division and this will assist drastically in terms of communication.

REFERENCES

- Busacca, M. (2013). Corporate Social Responsibility in South Africa's Mining Industry. *Redressing the legacy of Apartheid*. CMC Senior Thesis. Claremont McKenna College. Claremont.
- Creswell, J.W. (2009). *Research design: Qualitative, quantitative, and mixed methods approach*. 3rd ed. London: Sage
- Creswell, J.W. (2012). *Educational research. Planning, conducting and evaluating quantitative and qualitative research*. 4th ed. New York: Pearson.
- De Vos, A.S., Strydom., Fouche',C.B. & Delport, C.SL. (2011). *Research at grass roots: for the social Sciences and human service professions*. 4th Ed. Pretoria: Van Schaik.
- ESKOM Annual Report. (2008). ESKOM Holding Limited. Johannesburg.
- ESKOM INTEGRATED REPORT. (2013). Shift performance, grow sustainability.
- Godfrey, P.C., Merrill, C.B. & Hansen, J.M. (2009). 'The relationship between corporate social responsibility and shareholder value: An empirical test of the risk management hypothesis', *Strategic Management Journal*, 30(4): 425-445.
- Gradl, C. & Knobloch, C. (2010). *How to develop Business and Fight Poverty- Inclusive business Guide*. Endeava: Berlin.
- Hamann, R. (2009). 'South Africa: The Role of History, Government, and Local Context', in Idowu, S.O. and Filho, W.L. *Global Practices of Corporate Social Responsibility*, Springer, Berlin. 438-443.
- Karlsson, L.& Lindqvist, V. (2012). The perception and adoption of corporate social responsibilities: A case study of South Africa and Sweden. Business administration. Masters' Thesis. Karlstad University, Karlstad.

- Lincoln, Y.S & Guba, E.G. (1985). *Naturalistic Inquiry*. Beverly Hills, CA: Sage.
- Marais, H.C. (2001). *Sustainable Social Development: Critical issues*. South Africa, Network Publishers
- Mariri, T. & Chipunza, C. (2011). 'Corporate Governance, Corporate Social Responsibility and Sustainability: Comparing Corporate Priorities within the South African Mining Industry', *Journal of human ecology*, 35(2): 95-111.
- Masete, M.B. (2011). Corporate Social Investment Practitioners' Views regarding Eskom's contribution towards Integrated Community Economic Development. MSW. Dissertation. University of Pretoria, Pretoria.
- Moerane, T. (2013). Eskom: *Generation employees driving world class performance*. Megawatt Park, South Africa.
- Mousiolis, D.T. & Zaridis, A. (2014). The effects in the structure of an organisation through the implementation of policies from Corporate Social Responsibility (CSR). *Procedia-Social and Behavioral Sciences*, 148,634-638.
- Nadaf, Y.B.R. & Nadaf, S., M. (2014). Corporate Social Responsibility: Issues challenges and strategies for Indian firms. *IOSR Journal of Business and Management*, 16 (3),51-56.
- Patton, M. (1990). *Qualitative evaluation and research methods*'. London: Sage .
- Rhou, Y.,Singal, M., & Koh,Y. (2016). CSR and financial performance: The role of CSR awareness in the restaurant industry. *International Journal of Hospitality and Management*,57, 30-39.
- Shongwe, A. (2008). The key role that Eskom plays towards Corporate Social Responsibility and Sustainability in South Africa. MBA. Dissertation. University of KwaZulu-Natal, Durban.
- South Africa. Department of Public Enterprises. (2000). *An Accelerated Agenda Towards the Restructuring of State Owned Enterprises: Policy Framework*, Government Printer, Pretoria.
- Tesch, R. (1990). *Qualitative Research: Analysis Types and Software Tools*. New York : Falmer.
- Varadrajana, R & Kaul, R. (2017). Doing well by doing good innovations: alleviation of social problems in emerging markets through corporate social innovations. *Journal of Business Research*: In the Press.

EXPLORING THE RELATIONSHIP BETWEEN A LIVING WAGE AND HUMAN RESOURCES OUTCOMES: EVIDENCE FROM TSHWANE MARABASTAT MALL

Molefe Jonathan Maleka
Tshwane University of Technology, South Africa

ABSTRACT

The primary objective of this study was to explore the relationship between a living wage (i.e. household income) and human resources outcomes (i.e. fairness, dignity, and quality of life). The literature revealed that there are different theories of a living wage related to human resources outcomes. The research approach was the quantitative method and the research design was a survey. The unit of analysis comprised low- and middle-income workers. A purposive sampling technique was used to sample the respondents (n=205). The main findings of the study were that the relationship between a living wage and human resources outcomes is not linear, but S-shaped or cubic. Recommendations and the implications for different stakeholders (i.e. employers, government, unions, and society) are provided.

Keywords: Dignity, household income, fairness, Marabastat Mall, quality of life.

INTRODUCTION

Wage inequality is a global phenomenon and there are different instruments that are used to measure it (Piketty, 2015). One of the measuring instruments is the Gini coefficient, which “means that a coefficient of zero (0) indicates that income inequality is shared amongst everyone; a coefficient of one (1) indicates that a person earns all the income, whereas everyone earns nothing” (Van Eeden, 2014: 200). Research revealed that South Africa’s Gini coefficient is twice as high as the average of 0.31 in the Organisation for Economic Co-operation and Development (OECD) countries. On the contrary, New Zealand’s Gini coefficient of 0.32 is closer to 0.31. Denmark and Sweden both have Gini coefficients of 0.25. It is argued that the ideal Gini coefficient should range between 0.25 and 0.4, and since South Africa’s Gini coefficient is higher than the ideal range, it has high inequality in wages between high- and low-income workers (Massie, Collier & Crotty, 2014).



There are opposing views regarding the implementation of a living wage (Baker, 2007). Those who are not in favour of or who caution against the implementation of a living wage argue that it would increase unemployment and exacerbate inequality levels (Seekings & Nattrass, 2015). There is evidence that employers in the textile industry restructured their workplaces by replacing employees with machines in response to the implementation of a living wage (Godfrey, Maree, Du Toit & Theron, 2014). It is argued that “labour legislation and minimum wages make labour less attractive as a production factor” (Roux, 2014, p. 65). Conversely, it has been found that employees who earn a living wage are motivated and their morale is high (Brenner, 2005), they are committed to their employers and perform better (Judge, Piccolo, Podsakoff, Shaw & Bruce, 2010), their life satisfaction levels are high (George & Brief, 1989; Bussin, 2015), and they make their employers profitable, sustainable (Fisher, 2010), and efficient (Arrowsmith, Gilman, Edwards & Ram, 2003). In South Africa it has been found that the majority of low-income employees earn below the average household income of R4 125.

A literature review indicated that wage inequalities have been well researched; however, there is a dearth of research on how household incomes or living wages enhance human resources outcomes in the South African

context. Internationally, Carr, Parker, Arrowsmith, Haar and Jones (2015b) used exploratory factor analysis (EFA) to cluster human resources outcomes and used regression to predict the relationship between a living wage and human resources outcomes.

THEORETICAL FRAMEWORK

According to Anker (2011: 22), a living wage has three components: living standard, number of persons supported by the living wage, and number of persons in the household expected to work full-time to provide support. It can be deduced that a living wage is a broad construct that empowers workers to live in prosperity, and in this study living wage is defined as the income earned by workers to meet their basic needs (Levy & Venter, 2015) and that enables them to live a good-quality life (Makhubu, 2016).

There are different kinds of living wages theories. One of them states that the relationship between wages and pay satisfaction is linear (Judge et al., 2010). The other theories state that the relationships between wages and other human capabilities or something they value are sigmoidal , logarithmic , or cubic  (Carr, Parker, Arrowsmith & Haar, 2015a). Marxist theorists argue that the owner of production exploits the *lumpen proletariat* by paying them poor wages (Bendix, 2015). On the other hand, neo-classical theory states that employees must be treated the same as production factors, and those whose skills are not in demand should be paid lower wages (Slabbert, Parker & Farrel, 2015) and that implementing a minimum wage will lead to employers replacing employees with capital (i.e. technology or machinery) (Louw, 2014). All these theories, except for the linear theory, were developed by econometricians using macro-economic factors such as household subsistence level (Bendix, 2015) and consumer price index (Levy & Venter, 2015) and not human resources factors like social justice, fairness, job satisfaction, dignity (Fairris & Reich, 2005), and wellbeing (Yoshikawa, Aber & Beardslee, 2012).

The hypotheses of the study are as follows:

- The relationship between household income and fairness is linear; sigmoidal, logarithmic or cubic;
- The relationship between household income and dignity is linear; sigmoidal, logarithmic or cubic; and
- The relationship between household income and quality of life is linear; sigmoidal, logarithmic or cubic.

METHODOLOGY

This section discusses the research approach, data collection, analysis, validity, reliability, and ethics.

Research approach

In order to address the primary objective of the study, the research approach was quantitative and the epistemology was positivism. The quantitative research approach was appropriate in this study because it enabled the researcher to quantify (Creswell, 2014) the relationship between household income and human resources outcomes. The research design was also cross-sectional (Bless, Higson-Smith & Sithole, 2013). The respondents in this study were low-income workers (i.e. security guards, cashiers, garbage collectors, caretakers, construction and domestic workers, trolley porters, and stationery packers) and middle-income workers (i.e. teachers, financial advisors, marketing managers, and technicians). Purposive sampling techniques were used to select respondents (n=205). The biographical information of the respondents is shown in Table 1:

Table 1: Demographic information

Variable	Frequency
Gender	
Male	116
Female	89
Union member	
Yes	14
No	188
Did not respond	3
Employment status	
Full-time	125
Part-time	73
Unemployed	6
Did not respond	1
Number of people in the household	
One	14
Two	16
Three	42
Four	60
Five	44
Six and more	29

Data collection, analysis, validity, reliability, and ethics

Data were collected at the Tshwane Mall, near the Marabastad railway station. The questionnaire was originally developed by Massey University by academics for employees from labour and business sectors (Carr et al., 2015b). The questionnaire had six sections: demographics, quality of work life, quality of life, working arrangements, pay, and living arrangements. The data were coded in Excel in South Africa and analysed at Massey University in February 2016 using SPSS version 23. Descriptive statistics was conducted in frequency tables, and inferential statistics comprised of curve estimation. The independent variable in the study was household income, and the dependent variables were fairness ($\alpha = 0.86$), dignity ($\alpha = 0.61$), and quality of life ($\alpha = 0.72$). Face validity was achieved by piloting the research instrument in October 2015. Prior to data collection, the research instrument was piloted on 10 respondents visiting the Tshwane Mall. Through piloting, it became clear that the respondents were reluctant to complete or answer the questions on joint household income, net income, and rate of pay on an hourly, daily, weekly, and monthly basis. Prior to the data collection, the researcher was given ethical clearance by the Management Science Ethics Committee at Tshwane University of Technology in September 2015. The respondents participated voluntarily in the study, and even though they were requested to give their contact details for participation in future studies, no-one was coerced to do so.

RESULTS

The findings of this study are divided into two sections: descriptive and inferential. As can be observed in Table 1, in terms of the former, the majority of the respondents (57%) were males and most (92%) of them were not unionised. Also, the majority (61%) of them were employed full-time and most (71%) of them lived with three or more people in their household.

Exploring the relationship between a living wage and human resources outcomes

To explore whether the relationship between a living wage and human resources outcomes is linear or non-linear, regression was calculated. As can be observed from Figures 1 to 4, the relationship was not linear but rather S-shaped or cubic. As can be observed from Figures 1 and 3, the peak around the mid-point was R10 000.00.

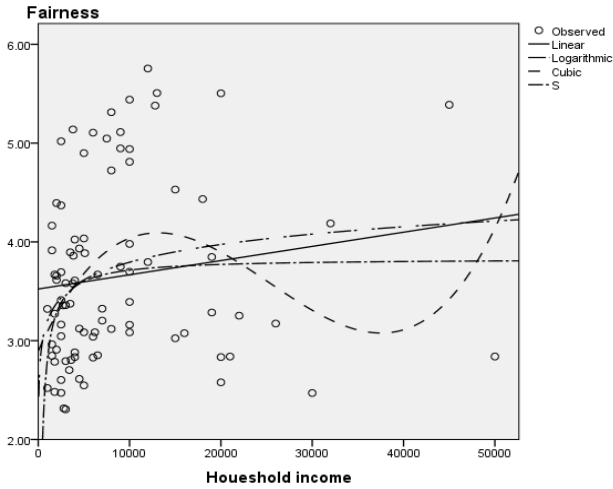

Figure 1: Household income and fairness

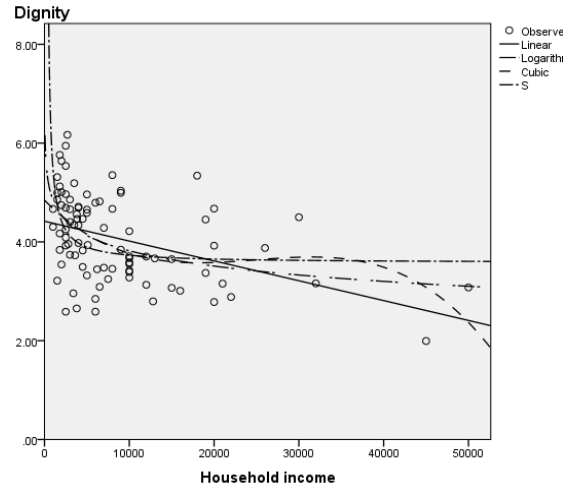

Figure 2: Household income and dignity

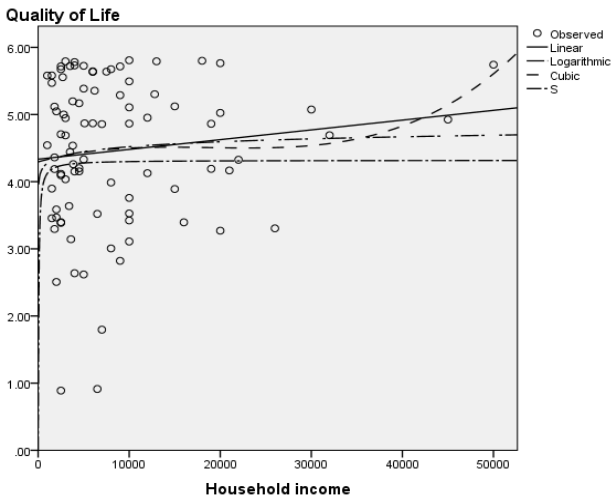

Figure 3: Household income and quality of life

The tables below are the model summary that show which lines were the best fit for the data.

Table 4: Model summary and variable fairness

Equation	Model summary			
	R Squared	F	df	Sig.
Linear	0.026	2.336	1	0.179
Logarithmic	0.065	6.155	1	0.014
Cubic	0.102	3.250	3	0.026
S	0.052	4.800	1	0.010

The independent variable was “If you don’t mind us asking, how much did your household have last month?” (thus rate of pay in ZAR per month).

As can be observed from Figure 1, the relationship between household income and fairness was non-linear, but it was a S-shaped or a cubic Bezier-like curve. It can also be seen from the same figure that there was a presence of data above the Bezier-like curve. From Table 5, logarithmic, cubic, and S provided significant fits to the data. The F-test and variance (R-squared) showed that S was the best-fitting curve and its cubic function for S curve was $y = 2.99 + .000x - 8.89^2 + 1.40x^3$.

Table 5: Model summary and variable dignity

Equation	Model summary			
	R-squared	F	df	Sig.
Linear	0.172	18.316	1	0.000
Logarithmic	0.213	23.839	1	0.000
Cubic	0.221	8.113	3	0.004
S	0.160	16.806	1	0.000

The independent variable was “If you don’t mind us asking, how much did your household have last month?” (thus rate of pay ZAR per month).

As can be observed from Figure 2, the relationship between household income and dignity was non-linear, but it was an S-shaped or cubic Bezier-like curve. It can also be seen from the same figure that there was a presence of data above the Bezier-like curve. From Table 6, logarithmic, cubic, and S provided significant fits to the data. The F-test and variance (R-squared) indicated that logarithmic was the best-fitting curve and its cubic function for S curve was $y = 4.84 + 0.00x + 7.48x^2 - 1.00x^3$.

Table 6: Model summary and variable quality of life

Equation	Model summary			
	R-squared	F	df	Sig.
Linear	0.015	2.445	1	0.120
Logarithmic	0.052	9.081	1	0.003
Cubic	0.071	4.201	3	0.007
S	0.071	12.635	1	0.000

The independent variable was “If you don’t mind us asking, how much did your household have last month?” (thus rate of pay ZAR per month).

As can be observed from Figure 3, the relationship between household income and quality of life was non-linear, or an S curve. It can also be seen from the same figure that there was a presence of data above the Bezier-like curve. From Table 6, logarithmic, cubic, and S provided significant fits to the data. The F-test and variance (R-squared) showed that S was the best-fitting curve and its cubic function for S curve was $y = 4.29 + 3.84x - 2.15x^2 + 3.83x^3$.

DISCUSSION

The purpose of the study was to determine the relationship between a living wage and human resources outcomes of low- and middle-income workers visiting the Tshwane Marabastat Mall. The study results replicated other international research because it was found that most of the respondents in the lowest income bracket said that the wages they earned were not enough to afford basic needs (Smith, 2015). Similarly, other data in the United States of America (USA) showed that employees earning low wages lived below the poverty threshold (United States Census Bureau, 2013). In South Africa, it was found that employees who earned R2 000 a month could not afford private medical healthcare (Makhubu, 2016). Theoretically, this study showed that the relationship between household income and human resources outcomes is cubic (Carr et al., 2015a) and not linear (Robbins & Judge, 2015).

This study had limitations. Firstly, it was conducted on a small sample size (n=205) and it was cross-sectional. Also, a non-probability sampling technique was used, and as a result its results cannot be generalised to the target population (Struwig & Stead, 2013). Despite these limitations, this study contributed to existing literature by providing an understanding of how a living wage relates to human capabilities, on which there is currently a dearth of research in the South African context.

Based on the study results, it is recommended that future research should entail solicited perceived living from low-income workers through face-to-face in-depth interviews using open-ended questions. Also, similar studies should be conducted using a probability sampling technique, so that the results can be generalised to the target population. It is also recommended that a longitudinal study be conducted so that it can be observed how a living wage impacts human capabilities over a long period of time. For organisations, it is recommended that they review their remuneration stance, because by not paying employees a living wage they might disadvantage themselves by having disgruntled low- and middle-income workers.

The study has implications for various stakeholders. Employers might be disadvantaged because employees who are not satisfied are less productive (Griffin, Phillips & Gully, 2014). Unions and employers might struggle to manage non-unionised members because they might embark on illegal strikes and render workplaces ungovernable and unprofitable (Dlangamadla et al., 2013). Having employees who cannot save money will in future affect welfare expenditure because the government will have to pay retired low-income workers a social grant. At community and societal level, since employees are earning lower wages and living below the poverty threshold, they will not be able to afford basic needs such as medical care (Makhubu, 2016).

In conclusion, the data and literature have shown that not paying employees a living wage robs them of human resources outcomes. As researchers we are aware that the results of this study might not be a panacea to total eradication of poverty, and contradict neo-classical economic theory; however, our findings showed that not paying employees a living wage affects their dignity and their quality of life.

REFERENCES

- Anker, R. (2011). Estimating a living wage: A methodological review. *International Labour Organisation* 29: 1-126.
- Arrowsmith, J., Gilman, M.W., Edwards, P. & Ram, M. (2003). The impact of the national minimum wage in small firms. *British Journal of Industrial Relations* 41(3): 435-456.
- Baker, F. (2007). *The South African labour market: Theory and practice*. Hatfield: Van Schaik.
- Bendix, S. (2015). *Labour relations: A Southern African perspective*. Cape Town: Juta and Company Ltd.
- Bless, L., Higson-Smith, C. & Sithole, S.L. (2013). *Fundamentals of social research. An African Perspective*. Claremont: Juta and Company Ltd.
- Brenner, M. (2005). The economic impact of the Boston living wage ordinance. *Industrial Relations* 44(1): 59-83.
- Bussin, M. (2015). Minimum wages come at a price. We need evidence-based and not-sentiment decisions regarding minimum. *HR Future*.
- Carr, S.C., Parker, J., Arrowsmith, J. & Haar, J. (2015a). *The business of inclusion*. Presented at the 30th Annual Conference of the Society for Industrial and Organisational Psychology. Philadelphia, USA, 23-25 April.
- Carr, S.C., Parker, J., Arrowsmith, J., Haar, J. & Jones, H. (2015b). Can a “living” wage boost human capability? *International Labour Organisation*. In press.
- Creswell, J.W. (2014). *Research design*. 4th ed. Los Angeles: Sage Publications Inc.
- Dlangamadla, F., Jika, T., Ledwada, L., Mosamo, S., Saba, A. & Sadiki, L. (2013). *We are prepared to kill each other: The Marikana story*. Cape Town: NB Publishers.
- Fairris, D. & Reich, M. (2005). The impacts of living wage policies: Introduction to the special issue. *Industrial Relations: A Journal of Economy and Society* 44(1): 1-13.
- Fisher, C.D. (2010). Happiness at work. *International Journal of Management Review* 12: 384-412.
- George, J.M. & Brief, A.P. (1989). The economic instrumentality of work: An examination of the moderating effects of financial requirements and sex on the pay-life satisfaction relationship. *Academy of Management* 1: 209-213.
- Godfrey, S., Maree, J., Du Toit, D. & Theron, J. (2014). *Collective bargaining in South Africa*. Cape Town: Juta & Co. Ltd.
- Griffin, R.W., Phillips, J.M. & Gully, S.M. (2014). *Organizational behaviour: Managing people and organizations*. Boston: Cengage Learning.
- Judge, T.A., Piccolo, R.F., Podsakoff, N.P., Shaw, J.C. & Bruce, L.R. (2010). The relationship between pay and job satisfaction: A meta-analysis of the literature. *Journal of Vocational Behaviour* 77: 157-167.
- Levy, R. & Venter, A. (2015). *Labour relations in South Africa*. 5th ed. Cape Town: Oxford University Press.
- Louw, A. (2016). Zero minimum wage equals maximum shame. *Sunday Times*, 1 May: p5.
- Makhubu, N. (2016). Tuks reaches deal with the insourcing. *Pretoria News*, 15 February: p1.

- Massie, K., Collier, D. & Crotty, A. (2014). *Executive salaries in South Africa*. Sunnyside: Jacana Media (Pty) Ltd.
- Piketty, T. (2015). *The economics of inequality*. London: The Belknap Press.
- Robbins, S.P. & Judge, T.A. (2015). *Organisational behavior*. 16th ed. Boston: Pearson Education Limited.
- Roux, A. (2014). *Everyone's guide to the South African economy*. 11th ed. Cape Town: Zebra Press.
- Seekings, J. & Nattrass, N. (2015). *National minimum wage-setting in South Africa*. Cape Town: Centre for Social Science Research, University of Cape Town.
- Slabbert, J.A., Parker, A.J. & Farrel, D.V. (2015). *Employment relations management. Back to basics: A South African perspective*. Durban: LexusNexis.
- Smith, L. (2015). Reforming the minimum wage: Toward a psychological perspective. *American Psychologist* 70(6): 557-565.
- Struwig, F.W. & Stead, G.B. (2013). *Research: planning, design and reporting*. 2nd ed. Boston: Pearson Education Limited.
- United States Census Bureau. (2013). *Poverty thresholds*. [Online]. Retrieved from <http://www.census.gov/hhes/www/poverty/data/threshld/index.html> [Accessed: 2 June 2016].
- Van Eeden, D. (2014) (Eds). *The Role of the Chief Human Resources Officer Perspectives, Challenges, Realities and Experiences*. Johannesburg: Knowledge Resources.

ARE THE INDEPENDENT HOTELS IDENTIFIED WITH USALI?

Cátia Malheiros, Conceição Gomes, Luís Lima Santos, Paula Cardoso
Polytechnic Institute of Leiria, Portugal

ABSTRACT

The Uniform System of Accounts on Lodging Industry (USALI) has been recognized as one of the management accounting techniques used in hotels. USALI is a powerful management accounting technique as it allows the standardization and comparability of information. Nevertheless, USALI has had a higher degree of usage in hotel chains, given the fact that it is used to support the information processing. The purpose of this research is to understand how USALI is used in independent hotels and how it should be used. The research analyses the importance and the adaptability of USALI in independent hotels. To accomplish the aim and objectives, the Portuguese case was analyzed by conducting a survey to obtain data, which has then been submitted to a statistical analysis. It was concluded that, regarding operating departments, the most frequently used are: “Rooms” and “Food & Beverage” (F&B). According to the findings, several schedules were created, based on the items that independent hoteliers considered important.

Keywords: USALI, independent hotels, lodging industry, management accounting.

INTRODUCTION

The lodging industry contributes significantly to global tourism revenues in Portugal. As it is known, Portugal has many small independent hotels and hoteliers have to optimize the decision making process. This fact is observed in other countries as well. Management accounting provides useful information for this process. In the lodging industry, the Uniform System of Accounts for the Lodging Industry (USALI) is used to process data similarly, enabling benchmarking between hotel companies. USALI is a flexible system that can be adapted to each situation. Therefore, some parts of the schedules, sub-schedules, items and sub-items should be eliminated for the independent hotels. USALI has a huge amount of information which could cause a constraint to independent hotels. Furthermore, they think that USALI is very complex and they do not want to use it. This research focuses on Part I of USALI, Operating statements, and it is applied to the independent hotels of Portugal. This paper is structured as follows: first, there is a literature review about USALI. Next, the methodology used on the research is described. In the last part of the paper, there is a detailed analysis of research findings and conclusions.

LITERATURE REVIEW

Tourism activity is very important for the Portuguese economy as it was directly responsible for 6.4% of the GDP and 8.1% of total employment in 2016, with growth estimates for both indicators for 2017 (WTTC, 2017). The lodging industry is a core tourism activity as the definition of tourist implies accommodation. In Portugal hotels represent the main type of accommodation with 40% of accommodation establishments, local accommodation not included. As far as category is concerned, hotels classified with 4 stars lead the offer, representing 33% of hotels, followed by hotels with 3 stars (30%) (INE, 2016). Hotels classified with 5 stars represent only 9% of the offer (INE, 2016).

Information provided by management accounting is useful for decision making and to improve its quality (Santos et al. 2010; Zounta & Bekiaris, 2009; Briciu et al., 2013; Persic et al., 2013). Schmidgall (2011) refers that income statement (statement of earnings or the profit and loss statements) reports the income of a hotel. Nowadays, hoteliers ask for more internal information than the one in reports. In the hospitality industry there are uniform systems of accounts where data is processed similarly. The four systems available in the hospitality industry are: Uniform System of Accounts for the Lodging Industry (USALI), Uniform System of Accounts for Restaurants (USAR), Uniform System of Financial Reporting for Clubs (USFRC) and Uniform System for Financial Reporting for Spas (USFRS) (Schmidgall & DeFranco, 2015a). Schmidgall & DeFranco (2015a) refer to USALI as a big brother of the other systems.

USALI results from the combination of three major publications: a) the 9th edition of Uniform System of Accounts for Hotels (USAH), which was first published in 1926 by the Association of New York City (HANYC); b) the Uniform System of Accounts for Smaller Hotels and c) the Expense Dictionary, where expenditures were categorized under specific accounts (Ni, 2011). “A separate edition for smaller properties was last published in 1987” (Schmidgall, 2014:44). The separate edition for small properties was discontinued in 1996 (Schmidgall, 2014). USALI has been revised several times and terminology has changed through the eleventh editions (Schmidgall & DeFranco, 2015a; Schmidgall, 2014). USALI’s 11th revised edition is the result of numerous changes to the original one and data is made available by department (operating departments, undistributed operating departments) (Schmidgall & DeFranco, 2015a; Persic & Jankovic, 2010). This edition has a more detailed and more practical information than the previous. Another new aspect is the metrics (available rooms, sold rooms, occupancy, ADR, Rooms RevPAR and TRevPAR) on top of summary operating statement (Schmidgall & DeFranco, 2015b). The 11th edition had effect on January 1st, 2015 (Schmidgall & DeFranco, 2015b). According to the Financial Management Committee (FMC) of the American Hotel & Lodging Association, USALI currently has the following purpose: “operating statements that are formatted to provide hotel owners, managers, and other interested parties with information and data that are pertinent to the unique operating environment of the lodging industry” (HANYC, 2014, p. XII). These standards represent the effort to make one uniform system applicable to hotel operations throughout the world (HANYC, 2014).

USALI acts as an accounting guidebook or a handbook, providing a high level of detail of departmental performance reports in which accounts are grouped based on revenues and expenses (Persic & Jankovic, 2010; Ni, 2011; Schmidgall & DeFranco, 2015). This system is adaptable to all kinds of hotels and provides internal accounting information, allowing the comparability among hotels (Kosarkoska & Mircheska, 2012; Schmidgall & DeFranco, 2015). The implementation of USALI implies a manual of procedures, where the new rules and the new routines to perform will be designated (Marassi et al., 2015). In order to reflect changes in hotelier practices, USALI is periodically revised. The 11th edition is divided into five parts: I) Operating Statements; II) Financial Statements; III) Financial Ratios and Operating Metrics; IV) Revenue and Expense Guide; V) Gross vs. Net Reporting (HANYC, 2014). Part I has the Operating Statements that were developed for full-service properties. These can be easily adapted to limited-service properties just by taking out those schedules that do not apply to their business (HANYC, 2014). Regarding Operating Statements, the main focus goes to rooms and food departments. The hotel is organized by profit centres and service centres (Schmidgall, 2011). According to USALI there are two Summary Operating Statement, one for operators and another one for owners. However, both statements are identical until the part of “earnings before interest, taxes, depreciation and amortization” (EBITDA). All the schedules have included information for the current period and for the year-to-date. In each of these periods there are three columns of information including current, budget and prior year. All revenues and expenses should be shown as monetary unit and as percentage (HANYC, 2014).

Concerning operating revenue, there are four categories: “rooms”, “food and beverage”, “other operating departments” and “miscellaneous income” with several items (HANYC, 2014). USALI states three categories of expenses: departmental expenses, undistributed operating expenses and non-operating expenses. Regarding departmental expenses with respect to an operated department revenue (“rooms”, “food and beverage” and “other operating departments”) each operated department has departmental expenses separated in four groups: “cost of sales”, “cost of other revenue”, “labor cost and related expenses” and “other expenses”, with several items. Undistributed operating expenses report expenses related to all the hotel which are not allocated to other

departments. There are five categories: “administrative and general”, “information and telecommunications systems”, “sales and marketing”, “property operation and maintenance” and “utilities” with several items (HANYC, 2014).

Nevertheless, Patiar (2016) criticizes USALI, since it does not provide accurate data. USALI only allocates direct costs. Indirect costs remain in a pool and they are apportioned to the total income. So, this author refers that USALI fails in identifying the exact expense of each department and service. The last edition of USALI remains based on traditional cost, it does not apply to activity-based cost nor allocate indirect costs. According to Georgiev (2016) USALI should be more internationally directed, for the system to be applicable worldwide. USALI does not provide information per guest segments, which is very important for the marketing department.

Howsoever, USALI is widely used in the country where it was born (United States of America). In Spain, Planas (2004) verified that international chains used USALI more than national chains. The way USALI is used is not homogeneous, because departments differ across hotels. In Greece, Zounta & Bekiaris (2009) refer that there is not any Greek Uniform System of Accounts for hotels. The hotels follow a general system of accounts, but about 70.8% of hoteliers believe that a system of accounts for hotels is a necessity. Pavlatos & Paggios (2007) noticed that only 2.9% of national chains or independent hotels used USALI. In Macedonia, the majority of hoteliers knows USALI but does not use it. However, they are ready to learn and to implement this uniform system. Macedonian hoteliers developed their own financial report with similar indicators, allowing only a comparison within their country (Kosarkoska & Mircheska, 2012). In Croatia, Persic & Jankovic (2010) show 84% of USALI adoption but there is not any data concerning the percentage of use in independent hotels. USALI has been used for 20 years (Persic et al., 2013). Nevertheless, Croatian hotels only use two departments: “rooms” and “food and beverage”. In China, the hotel industry does not use USALI - each hotel makes its own record. However, it is an urgent priority to develop a uniform system of accounts for all kinds of hotels. It was referred that through professional networks and industry associations, it will be possible to adopt a uniform system (Yu & Huimin, 2007). In Australia, hotels that are part of international chains follow management practices that are independent of their location (Patiar, 2016). In Bulgaria few hoteliers know USALI, but they are interested in this new technique (Georgiev, 2016).

In Portugal, Faria et al. (2012) state 50% of USALI adoption in hotels of 4 and 5 stars in the Algarve region. In the case of independent hotels the percentage reaches 52.4%. According to Faria et al. (2015), the Portuguese Hotel Association (*Associação de Hotéis de Portugal - AHP*) made the first inquiry about the use of USALI in Portugal. The authors report that the levels of USALI adoption are reduced, except in the city of Lisbon and in some hotels in Algarve. Regarding the region of Algarve, recent studies show that 50% of the enquired adopt USALI (Faria et al., 2015). Gomes et al. (2015) refer that USALI is not used by most hotels in Portugal. USALI is essentially used for the decision making process, to prepare budgets and as a source of information of control systems. The hotel managers demonstrated a high degree of satisfaction using USALI to define costs, profitability analysis of products, pricing and profitability analysis of the markets. These authors have also determined the factors that influence the adoption of USALI, such as competitiveness in promotion, size (number of employees) and when the decision-making is carried out at operational level. Correia et al. (2016) have done a research about the items that should be used in independent hotels, but the sample was small and it was the beginning of this research. In Portugal a hospitality management accounting book was developed, where the USALI schedules are shown, but applied to the Portuguese reality (Santos et al., 2016).

Taking into account the size of hotels, Schmidgall & DeFranco (2015) refer that USALI is completely flexible in terms of schedules, sub-schedules and items. In other words, it could be adapted for those small hotels in which some items, sub-schedules and schedules should be reduced, as well as in large hotels, where some necessary items, sub-schedules or schedules could be added. Planas (2004) noticed that 63% of Spanish small independent hotels have adopted USALI. In Brazil, the number of micro hotels that do not use a cost system is huge (Lunkes, 2009). According to Dearden (1963), management accounting techniques should be adapted to small businesses, what it is corroborated by López & Hiebl (2015), when they referred that SMEs use management accounting in a different way. Regarding the accounting practices in Portugal, Lima Santos et al. (2012) have noticed that only the big hotels with foreign management adopt USALI. This is in line with the findings of Faria et al. (2015).

According to Planas (2004) and Schmidgall (2011), USALI can be adapted by large and small hotels. Schmidgall (2014) states that USALI intends to meet the hoteliers' needs. In these terms, the main question is "what happens if small hotels remove several items and schedules? Which of them are they not going to use?". According to Schmidgall & DeFranco (2015a), many owners of small hotels have no idea of how to classify revenues and expenses as well as the reporting of those items.

As mentioned above, this research focuses on the case of Portugal. Hence, the aim of this study is to propose the use of USALI for small independent hoteliers, which will include all the information they require. The decision process of hoteliers is not adequate, with the miscellaneous information available. If USALI allows line items to be removed and if it provides the necessary information to hoteliers, why not create a USALI for small independent hotels? It existed previously and there are not records related to inefficiency in the use of information. Weygandt et al. (2005) refer that from 1930s to 1970s there was the Uniform System of Accounts for Smaller Hotels, when most hotels were smaller.

METHODOLOGY

A structured survey was developed to serve as main data for this study. The survey was available on an online platform and was conducted between March and December 2016. The questionnaire was applied to hotels in the Leiria and West regions (95 hotels). The sample was defined considering a percentage of independent hotels in the order of 60% (Deloitte, 2016), making a total of 57 independent hotels. Assuming a confidence interval of 95% and a margin of error of 5%, a sample of 49 questionnaires was determined. An email was sent to the CEOs of these hotels, containing an individual link to the online survey.

CEOs were asked to provide information about the hotel unit description (management type, number of stars, employees, rooms and available F&B seats, last available year turnover, existing departments) and they were also asked to indicate the significant revenue and expenses item, that should be used by hoteliers.

A total of 49 surveys was collected, but only 41 of which were independent hotels, so 8 answers needed to be removed from the sample. These 8 hotels belong to a chain. The data was processed using SPSS. Descriptive statistics was used, in order to characterize the sample, ascertain what departments were used and determine the revenue and expenses accounts used by hoteliers. In this sample, there are only micro, small and medium-sized hotels, taking into account EU recommendation 2003/361.

Results

In this study, 41 hotels in Portugal were analysed, and the concentration of hotels falls under the 4-star classification (41.5%). Regarding the number of employees, the sample is featured with a mean of 27 employees. The turnover confirms this profile (small enterprise), with a mean of 1.8 EUR millions.

When asked about departmental management, 63% of hoteliers replied that their units were organized by departments. The two most often common departments are the two traditional major operating departments: "Rooms" and "Food & Beverage" (F&B). Considering other mentioned departments, some hoteliers mentioned the following as other departments: "Maintenance", "Housekeeping" (floors), "Conferences and Banquets", "Swimming pool", "Laundry", "Marketing", "Human resources", "Administrative" and "Surf".

The survey also tried to identify which revenue items would be significant within the two major operational departments. It was ascertained that all respondents mentioned an interest in the "Rooms" department. Within this main item, they mentioned an interest in all the named sub-items. However, it is possible to verify that the item "Groups" is one that has less interest to 41% of respondents. All other sub-items are above 66%, which shows that it has relevance to respondents (Corporate, Retail, Tour/Wholesalers, Wholesalers, Other Revenue).

In the "F&B" department, the results of its various sub-items state substantial differences. In fact, about 54% of respondents mentioned an interest in F&B. The various sub-items of F&B department obtained more diverse rates of significance and lower in relation to the F&B department when compared to the rooms department.

This may be due to the fact that room revenue is traditionally the most important component of the overall hotel revenue, increasing concern among hoteliers to separate the various items of revenue. The sub-items “restaurants à la carte” and “in-rooms breakfast” stand out, with more than 50%. The items with lower significance are “catering”, “equipment rental” and “services charges”. As a result, and taking into account the items used in USALI, the chosen items (more than 50%) are represented by venue beverage revenue, venue food revenue, in-room dining beverage revenue, in-room dining food revenue and other revenue. Still concerning the “F&B” department, 63% of respondents mentioned the importance of separating food and beverages.

To the question “Which EXPENSES items would be significant for your hotel unit management?”, hoteliers have again demonstrated more interest in expenses of the two traditionally most important operational departments: “Rooms” (100%) and the “F&B” (66%). The least important was “Utilities” (32%). Regarding items of operated department revenue’s expenses and considering only the items that have reached at least 50% of response expressing interest, the items that most respondents considered important are all related to labour cost (salaries and wages, training, payroll taxes and contracted, leased and outsourced labour. It can be observed that there are lower results between 20% and 50%. As an outcome, considering the items used in USALI, the chosen items were the ones that had rates above 20% and one that hoteliers can use to register the miscellaneous expenses.

With this information, it is possible to design new schedules for small independent hotels, using USALI as a base. This allows the comparison of items and indicators among small independent hotels and others. A schedule proposed for rooms department is shown in Table 2 and for F&B department in Table 3.

Table 2: Rooms - Schedule	Table 3: F&B - Schedule
Revenue	Revenue
Transient Rooms revenue	Venue Food Revenue
Retail	Venue Beverage Revenue
Direct clients	In-Room Dining Food Revenue
Hotel website clients	In-Room Dining Beverage Revenue
Travel agencies clients	Other Revenue
Wholesaler	Expenses
Group rooms revenue	Cost of Sales
Corporate	Cost of Food Sales
Tour/Wholesales	Cost of Beverage Sales
Online operators’ clients	Total Cost of Food and Beverage Sales
Tour-Operators clients	Labor costs and related expenses
Other revenue	Salaries and wages
Total rooms revenue	Payroll taxes
Expenses	Training
Labor costs and related expenses	Contracted, leased and outsourced labour
Salaries and wages	Total labor costs and related expenses
Payroll taxes	Other expenses
Training	Banquet Expenses
Bonuses and Incentives	China
Contracted, leased and outsourced labour	Cleaning Supplies
Total labor costs and related expenses	Decorations
Other expenses	Equipment rental
Amenities	Flatware
Cleaning Supplies	Glassware
Commissions	Kitchen Fuel
Complimentary Services/Gifts	Kitchen Smallwares
Corporate Officie Reimbursables	Laundry and dry cleaning
Decorations	Menus and Beverage Lists
Entertainment	
Laundry and Dry Cleaning	
Linen	

<i>Licenses and Permits</i>	<i>Miscellaneous</i>
<i>Miscellaneous</i>	<i>Uniforms</i>
<i>Postage and overnight delivery charges</i>	<i>Total other expenses</i>
<i>Printing and stationery</i>	<i>Departmental profit</i>
<i>Reservations</i>	
<i>Uniforms</i>	
<i>Total other expenses</i>	
<i>Departmental profit</i>	
Source: prepared by authors based on HANYC (2014)	Source: prepared by authors based on HANYC (2014)

Regarding the departments of undistributed operating expenses, low percentages were found, within which the department administrative and general with 41.5%, the department information and telecommunications systems with 36.6%, the department sales and marketing with 43.9%, the department property operation and maintenance with 46.3% and the department utilities with 31.7%.

The items of the departments of undistributed operating expenses had results lower than 40%. However, the items between 20% and 40% could not be devalued, because at least 5 respondents considered it as significant. Based on these items, five schedules were elaborated for the departments of undistributed operating expenses, which should be used by independent hotels.

Findings of this research show that independent hoteliers believe in the usefulness of management accounting, as defended by Santos et al. (2010), Zounta & Bekiaris (2009), Briciu et al. (2013) and Persic et al. (2013).

According to Planas (2004) and Schmidgall (2011), USALI can be adapted by small hotels, where it is possible to remove some items. Weygandt et al. (2005) refer that from 1930s to 1970s there was the Uniform System of Accounts for Smaller Hotels, when most hotels were smaller. So, taking into account these findings, there are many items that the hoteliers think of as insignificant. Taking into account the large number of small independent hotels in Portugal, it is imperative to draw up a USALI for small independent hotels. It will allow a more simplified implementation. This kind of USALI can be expanded to other countries whose business structure is characterized by small enterprises. According to Dearden (1963), the use of some management techniques by small businesses was expensive and inefficient, therefore USALI for small independent hotels will be cheap and efficient.

CONCLUSIONS

USALI results from the combination of three major publications and it has been revised several times. USALI's 11th revised edition is the result of numerous changes to the original one and is prepared for large hotels, because it is able to find multiple schedules, sub-schedules, accounts, items, metrics and ratios. This system provides internal accounting information for comparison with other hotels and it is based on departments (Kosarkoska & Mircheska, 2012; Persic & Jankovic, 2010).

Regarding Schmidgall & DeFranco (2015), Planas (2004) and Schmidgall (2011), USALI can be adapted by large and small hotels, for there is a possibility of eliminating the useless items. Some criticisms are made to USALI in terms of the indirect costs, internationalization and information per guest segments (Patiar, 2016; Georgiev, 2016). However, these critiques can be changed as USALI is a flexible system. Therefore, a research was carried out, in order to ascertain the necessary departments as well as the items to use in the schedules.

Findings reveal that most hotels in the study (44.9%) are classified with four stars. Therefore, regarding independent hotels, this percentage changes to 41.5%. It was also verified that 63% of hoteliers organize their hotels by departments. In relation to operating departments, the most frequently used are: "Rooms" and "Food & Beverage" (F&B). About the other mentioned departments, some hoteliers mentioned other departments, such as: "Maintenance", "Housekeeping" (floors), "Conferences and Banquets", "Swimming pool", "Laundry", "Marketing", "Human resources", "Administrative" and "Surf".

The departments of undistributed operating expenses are underused; however, of the five departments, we highlight the property operation and maintenance, with the highest percentage of use (46%). With regard to revenue items and expenses items, schedules were created to be used by independent hotels. Moreover, the expenses items with the highest scores are related to labour costs. To sum up, it is necessary to reduce a lot of items and schedules, but this is a process that will encourage the implementation of USALI into independent hotels.

MANAGERIAL IMPLICATIONS

For managers of independent hotels this research is very helpful, because USALI was adapted to their reality. By applying the schedules that were indicated through this work, they will have tools that help them to compare with other hotels. This will allow them to sustain their businesses.

Another implication is that this a simplified USALI, with less items and less pages, which is aligned with the desire of hoteliers. This research shows a right direction to the hotel information processing, where concrete examples are shown.

REFERENCES

- Briciu, S., Scorțe, C. & Meșter, I. (2013). The impact of accounting information on managerial decisions – Empirical study conducted in the hospitality industry entities in Romania. *Theoretical and Applied Economics*, XX, 9(586), 27-38.
- Correia H., Santos L.L., Gomes C. & Ferreira R.R. (2016). «USALI adapted to the small Independent hotels», in Proceedings book of 2nd Annual Conference of the Euro-Asia Tourism Studies Association “A pathway for the new generation of tourism research”, Lisboa, Peniche e Coimbra (Portugal).
- Dearden, J. (1963). Profit planning accounting for small firms. *Harvard Business Review*, 66-76.
- Deloitte (2016). Atlas da Hotelaria (11.^a ed.). Consulted on 7 of April, 2016 in: <http://atlasdahotelaria.com/2016/>.
- Faria, A., Trigueiros, D. & Ferreira, L. (2012). Práticas de custeio e controlo de gestão no sector hoteleiro do Algarve. *Tourism & Management Studies*, 8, 100-107.
- Faria, A., Trigueiros, D. & Ferreira, L. (2015). A utilização do Uniform System of Accounts for the Lodging Industry (USALI) em Portugal: o caso do Algarve. *Revista Iberoamericana de Contabilidad de Gestión*, vol. XIII, n.º 26, Julho/Dezembro, 1-23.
- Georgiev, D. (2016), Applying the uniform system of accounts for the lodging industry (USALI) for the purposes of financial and management accounting, *Journal of Varna University of Economics*, 60(2), 154-166.
- Gomes, C., Santos, L.L. & Arroiteia, N. (2015). A adoção do USALI nas empresas hoteleiras em Portugal. XV *Congresso Internacional de Contabilidade e Auditoria*, Junho, Coimbra.
- Hotel Association of New York City (HANYC). (2014). *Uniform System of Accounts for the Lodging Industry*, 11th. New York: Revised Ed.
- Instituto Nacional de Estatística (INE). (2016). Estatísticas do Turismo - Inquérito à Permanência de Hóspedes na Hotelaria e Outros Alojamentos 2015, consulted on 7 th of April 2017 in: https://www.ine.pt/xportal/xmain?xpid=INE&xpgid=ine_publicacoes&PUBLICACOESpub_boui=265858123&PUBLICACOESstema=55581&PUBLICACOESmodo=2.

Kosarkoska, D. & Mircheska, I. (2012). Uniform system of accounts in the lodging industry (USALI) in creating a responsibility accounting in the hotel enterprises in Republic of Macedonia. *Procedia-Social and Behavioral Sciences*, 44, 114-124.

Lima Santos, L., Gomes, C. & Arroteia, N. (2012). Management Accounting Practices in the Portuguese Lodging Industry. *Journal of Modern Accounting and Auditing*, 8, 1, 1-14.

Lopez, O. & Hiebl, M. (2015). Management accounting in small and medium-sized enterprises: current knowledge and avenues for further research, *Journal of Management Accounting Research*, 27(1), 81-119.

Lunkes, R. (2009). Informações de custos: um estudo em empresas hoteleiras na cidade de Florianópolis. *Turismo em análise*, 20 (2), 345-368.

Marassi, R., Rosa, F. & Lunkes, R., (2015), USALI: Processo de institucionalização em uma rede de hotéis brasileira, XV Congresso Internacional de Contabilidade e Auditoria, Coimbra.

Ni, S. (2011). "Hotel Uniform Accounting in Special Administrative Regions of China: Current and Future Issues". Master of Philosophy dissertation, The Hong Kong Polytechnic University.

Patiar, A. (2016), Costs allocation practices: Evidence of hotels in Australia, *Journal of Hospitality and Tourism Management*, 26: 1-8.

Pavlatos, O. & Paggios, I. (2007). Cost accounting in Greek Hotel Enterprises: An empirical approach. *Tourismos*, 2, 2, 39-59.

Persic, M. & Jankovic, S. (2010). Performance benchmarking tool in the Croatian Hotel industry. EuroCHRIE, Amesterdão, outubro.

Persic, M., Jankovic, S. & Vlastic, D. (2013). Accounting standards as a support for quality decision making. *1st Dubrovnik International Economic Meeting*.

Planas, F. (2004). "La Contabilidad de Gestión en la Industria Hotelera: Estudio sobre su Implantación en las Cadenas Hoteleras en España", unpublished Ph.D. dissertation, Universitat Rovira i Virgili.

Santos, L.L., Gomes, C., Faria, A.R., Lunkes, R., Malheiros, C., Silva, F.R. & Nunes, C. (2016) Contabilidade de Gestão Hoteleira; ATF – Edições Técnicas; Lisboa. (ISBN 978-989-98944-3-3).

Santos, L.L., Gomes, C. & Arroteia, N., (2010). Management accounting practices in the Portuguese lodging industry. *European Journal of Tourism Hospitality and Recreation*, 1(1), 110-125.

Schmidgall, R. & DeFranco, A. (2015a). Uniform system of accounts for the lodging industry 11th revised edition: the new guidelines for the lodging industry. *The Journal of Hospitality Financial Management*, 23: 79-89

Schmidgall, R. & DeFranco, A. (2015b). The new guidelines and operating statements for 2015. *The Bottomline*, 30(1): 30-35.

Schmidgall, R. (2011). Hospitality industry managerial accounting 7th edition. USA: American Hotel & Lodging Educational Institute.

Schmidgall, R. (2014). Evolution of the uniform system of accounts for the lodging industry. *The Journal of Hospitality Financial Management*, 22, 41-57.

Weygandt, J. (2005). *Hospitality financial accounting*. New Jersey: John Wiley & Sons.

World Tourism Organization, WTTC (2017). Travel and Tourism Economic impact 2015, Portugal. United Kingdom. Consulted on 7 th of April 2017 in: <https://www.wttc.org/-/media/files/reports/economic-impact-research/countries-2017/portugal2017.pdf>.

Yu, L. & Huiming, G. (2007). An analysis of hotel financial management in China. *The Journal of Hospitality Financial Management*, 15(2), 39-48.

Zounta, S. & Bekiaris, M. (2009). Cost-based management and decision making in Greek Luxury hotels. *Tourismos*, 4(3), 205-225.

A FUZZY AHP-TOPSIS MODEL FOR THE ASSESSMENT AND SELECTION OF RENEWABLE ENERGY TECHNOLOGIES

Guilherme de Andrade Martins
Pontifical Catholic University of Rio de Janeiro, Brazil

Maria Fatima Ludovico de Almeida
Pontifical Catholic University of Rio de Janeiro, Brazil

Rodrigo Flora Calili
Pontifical Catholic University of Rio de Janeiro, Brazil

ABSTRACT

The aim of this paper is twofold: to propose a model for assessing and selecting renewable energy technologies, with the support of multicriteria fuzzy decision-making methods; and to demonstrate its applicability through the results of an empirical study concerning energy planning in the State of Rio de Janeiro (Brazil). The assessment of renewable energy technologies is addressed to improve efficiency in electrical system expansion decisions based on multiple criteria, namely economic, environmental, social, technical and political ones. The decision-making processes regarding the choice of renewable energy technologies can be characterized by subjectivity, uncertainty, and ambiguity. Due to such characteristics, multi-criteria decision making (MCDM) methods combined with fuzzy logic seem to be an adequate methodological approach for assessing and selecting these technologies. The results highlight the selection of the most appropriate technologies according to their environmental, social, economic, technical and political impacts and the applicability of the proposed model focusing the energy planning of the State of Rio de Janeiro. In this case, given the potential of renewable sources and respective impacts in this region the most appropriate technology was solar photovoltaic.

Keywords: Renewable energy technologies; multicriteria decision-making methods; fuzzy logic; sustainability.

INTRODUCTION

Renewable energy technologies have been considered crucial elements for sustainable, environmentally friendly, and cost-effective energy alternatives for the future. Georgopoulou *et al.* (1997) have previously argued that renewable energy technologies should be perceived as key solutions to meet the energy planning and environmental goals, although they may also have technical limitations compared to conventional energy sources.

Selecting the appropriate renewable energy technologies is a task that encompasses different factors and guidelines, which can be conflicting in most situations. Decision-making concerning renewable energy technologies can be regarded as a multiple criteria decision-making problem associating criteria with technological alternatives. Because of the complexity concerning the variables involved in such decisions, single criteria decision-making approaches are no longer able to handle such decision problems (Arcer *et al.*, 2015; Abu Taha & Daim, 2013; Wang *et al.*, 2009).

Besides complexity, the choice of renewable energy technologies can be characterized by subjectivity, uncertainty, and ambiguity, mainly associated with the level of perceived effectiveness of their adoption in the future (Troldborg *et al.*, 2014). Due to such characteristics, multi-criteria decision making (MCDM) methods combined with fuzzy logic seem to be an adequate methodological approach for assessing and selecting technologies. A fuzzy MCDM model can provide a technical-scientific decision-making support to justify the renewable energy choices consistently in a complex and uncertain environment (Şengül *et al.*, 2015; Ertay *et al.*, 2013; Kaya & Kahraman, 2010; Lee *et al.*, 2009).

Previous review articles on applications of MCDM methods in renewable energy analysis were identified in the exploratory phase of this research (Arçer *et al.*, 2015; Abu Taha & Daim, 2013; Wang *et al.*, 2009; Polatidis *et al.*, 2006; Zhou *et al.*, 2006; Pohekar & Ramachandran, 2004). Complementary to these preliminary findings, a systematic literature search was performed on peer-reviewed articles that were published between January 2006 and December 2016. It revealed that several researchers have attempted to integrate MCDM methods for renewable energy analysis (Rahman *et al.*, 2016; Štreimikienė *et al.*, 2016; Shmelev & Van Den Bergh, 2016; Hadian & Madani, 2015; Şengül *et al.*, 2015; Ertay *et al.*, 2013). These findings confirmed our assumption that a model which combines MCDM methods with fuzzy logic could provide an appropriate tool to support the assessment and selection of renewable energy technologies in different energy planning contexts. All of this suggests that renewable energy analysis requires innovative approaches due to the multi-dimensional and complex nature of the sustainability assessments.

From the renewable energy planning perspective, this paper aims to propose a model for assessing and selecting renewable energy technologies, with the support of two multicriteria fuzzy decision-making methods. The applicability of this model could be demonstrated through an empirical study concerning energy planning in the State of Rio de Janeiro (Brazil).

This article is structured as follows: Firstly, we reviewed multi-criteria applications in renewable energy analysis and confirmed the opportunity to investigate an integrated Fuzzy MCDM model for selecting renewable energy technologies alternatives in energy planning contexts. In section 3, we describe the research methodology. In Sections 4 and 5, we introduce the Fuzzy AHP-TOPSIS model and present the results of an empirical study in the State of Rio de Janeiro, covering five renewable energy technologies alternatives. Finally, in Section 6, we synthesize the concluding remarks and point out implications for future work.

THEORETICAL BACKGROUND

The theoretical background encompasses the following themes: (i) MCDM methods applied to renewable energy analysis; and (ii) fuzzy sets and fuzzy logic, with special attention to two fuzzy MCDM methods – the fuzzy analytical hierarchical process (FAHP) and the fuzzy technique for order preference by similarity to ideal solution (FTOPSIS).

Multi-Criteria Applications in Renewable Energy Analysis

Previous review articles on applications of MCDM methods in renewable energy analysis were identified in the exploratory phase of this research (Arçer *et al.*, 2015; Abu Taha & Daim, 2013; Pohekar & Ramachandran, 2004; Wang *et al.*, 2009; Polatidis *et al.*, 2006; Zhou *et al.*, 2006). Complementary to these preliminary findings, a systematic literature search was performed on peer-reviewed articles that were published between January 2006 and December 2016, by using the following keywords "multi-criteria", "multicriteria", "MCDM", with Boolean operator 'OR'. Further, the results of this search were combined with the keyword "renewable energy", using Boolean operator 'AND'. The final results revealed that several researchers have attempted to integrate MCDM methods in renewable energy analysis.

Table 1 summarizes and compares the research objectives and the MCDM methods reported in 20 studies, which were selected by their relevance to the intended modeling addressed to the assessment and selection of renewable energy technologies.

Table 1: Multi-criteria decision making (MCDM) methods applied in renewable energy analysis: 2006-2016

Reference	Objective	MCDM method
Rahman <i>et al.</i> (2016)	To present a methodological technique to assist in formulating, evaluating, and promoting the energy policy of a country.	Stochastic Multicriteria Acceptability Analysis (SMAA) and Long-range Energy Alternatives Planning (LEAP)
Štreimikienė <i>et al.</i> (2016)	To develop a multi-criteria analysis of electricity generation technologies in Lithuania.	Analytic Hierarchy Process (AHP) and Additive Ratio Assessment (ARAS)
Al Garni <i>et al.</i> (2016)	To develop and apply a multicriteria decision-making approach for evaluating renewable power generation sources in Saudi Arabia.	AHP
Shmelev & Van Den Bergh (2016)	To propose a multi-criteria analysis of alternative combinations of renewable energy technologies to meet a sustainable energy supply.	MARKAL Model and Aggregated Preference Indices System (APIS)
Hadian & Madani (2015)	To propose a system of systems (SoS) framework to determine the relative aggregate footprint (RAF) of energy supply alternatives with respect to different sustainability criteria and uncertain performance values.	Dominance, Maximin, Lexicographic, TOPSIS and SAW
Arcer <i>et al.</i> (2015)	To investigate the use of grey-based methods in multi-criteria decision analysis for the evaluation of sustainable energy systems.	GRA (Grey-based analysis) and MCDA
Şengül <i>et al.</i> (2015)	To develop a multi-criteria decision support framework for ranking renewable energy supply systems in Turkey.	Fuzzy Shannon's Entropy and Fuzzy TOPSIS
Purwanto <i>et al.</i> (2015)	To purpose a multi-objective optimization model for sustainable Indonesian electricity system, by analysis of economic, environment, and adequacy of energy sources.	Multi-objective optimization model with two goal functions
Trolborg <i>et al.</i> (2014)	To assess the sustainability of renewable energy technologies using multi-criteria analysis.	PROMETHEE
Santoyo-Castelazo & Azapagic (2014)	To purpose a framework for the sustainability assessment of energy systems, by integrating environmental, economic, and social aspects.	Multi-Attribute Value Theory (MAVT)
Ribeiro <i>et al.</i> (2013)	To evaluate future scenarios for the power generation sector by combining multi-criteria decision analysis (MCDA) tools.	Mixed Integer Linear Programming (MILP) model and Additive Value Function
Mourmouris & Potolias (2013)	To develop and apply a multi-criteria methodology for energy planning and developing renewable energy sources at a regional level.	REGIME
Ertay <i>et al.</i> (2013)	To evaluate renewable energy alternatives using MACBETH and fuzzy AHP multicriteria methods in Turkey.	MACBETH and Fuzzy AHP
Stein (2013)	To develop a comprehensive multi-criteria model to rank electric energy production technologies	AHP (Analytic Hierarchy Process)
Kaya & Kahraman (2010)	To propose a multicriteria renewable energy planning using an integrated fuzzy VIKOR & AHP methodology.	Fuzzy VIKOR-AHP
Lee <i>et al.</i> (2009)	To develop a decision support for prioritizing energy technologies against high oil prices: a fuzzy analytic hierarchy process approach.	Fuzzy AHP
Oberschmidt J <i>et al.</i> (2010).	To develop a modified PROMETHEE approach for assessing energy technologies.	Modified PROMETHEE
Chatzimouratidis & Pilavachi (2008)	To develop a sensitivity analysis of the evaluation of power plants impact on the living standard using the Analytic Hierarchy Process (AHP)	AHP
Diakoulaki & Karangelis (2007)	To develop a multi-criteria decision analysis and cost-benefit analysis of alternative scenarios for the power generation sector in Greece.	PROMETHEE and Cost-Benefit Analysis (CBA)
Burton & Hubacek (2007)	To purpose and apply a multicriteria assessment of small-scale energy technology applications in local governments.	MACBETH

Source: Based on the systematic literature search performed on peer-reviewed articles published between January 2006 and December 2016.

Although some authors have already developed fuzzy MCDM models to be applied in renewable energy analysis (Şengül *et al.*, 2015; Ertay *et al.*, 2013; Kaya & Kahraman, 2010; Lee *et al.* 2009), we could not identify among them any work addressed specifically to the evaluation and selection of renewable energy technologies. Thus, alternatively to the fuzzy MCDM models developed respectively by those authors, the present study combined two fuzzy-based methods – the fuzzy analytical hierarchical process (FAHP) and the fuzzy technique for order preference by similarity to ideal solution (FTOPSIS).

Fuzzy Sets and Fuzzy Logic

In the 1960's and 1970's decades, the concepts of fuzzy sets and fuzzy logic were introduced by Lotfi Zadeh. Since then, fuzzy logic has been used in several applications. According to Zadeh (1965; 1973), when the complexity of the system increases, the ability of human beings to describe the system behavior decreases. He argues that complex problems cannot be translated into numbers but rather into labels of fuzzy sets.

According to Yager (1977), the use of fuzzy sets stems from the fact that objectives can be represented in both ways – too vague or fuzzy goals or precisely defined objectives. Also, fuzzy sets permit that very subjective goals can be expressed. From this perspective, Yager (1977) emphasizes that fuzzy sets do not eliminate the subjectivity, which is a human phenomenon, but the decision maker becomes aware of the subjectivity involved. Fuzzy sets allow decision-makers to deal with a subjective occurrence and reasonably manage the decision situation.

Mardani *et al.* (2015) reviewed a total of 403 scientific papers about fuzzy MCDM methods that were published from 1994 to 2014 in more than 150 peers reviewed journals. However, fuzzy MCDM models focusing the assessment of renewable energy technologies were not included in their review article.

From the perspective of developing an integrated MCDM model for assessing and selecting renewable energy technologies in a fuzzy environment, we will focus on two fuzzy MCDM – the fuzzy analytical hierarchical process (FAHP) and the fuzzy technique for order preference by similarity to ideal solution (FTOPSIS).

The first method – fuzzy analytical hierarchical process (FAHP) – is an extension of the original AHP method created by Saaty (1980). It combines AHP method with the fuzzy set theory to solve fuzzy hierarchical problems (Taylan *et al.*, 2016; Yang *et al.*, 2015). According to these authors, the fuzzy AHP method can capture a human's assessment of vagueness when complex multi-attribute decision-making problems are considered. The steps in FAHP are summarized as follows: (i) building the evaluation hierarchy system for evaluating the alternatives considering the various criteria and sub-criteria involved; (ii) pairwise fuzzy comparison matrices using 'triangular fuzzy numbers' (TFN); (iii) consistency check of results from the pairwise comparison matrices; (iv) the weight for each criterion and sub-criterion is determined.

The second one – FTOPSIS – is a ranking multi-criteria decision-making tool that emerges as an alternative to the ranking step of AHP method (Shahrabi, 2014; Wittstruck, & Teuteberg, 2012; Torfi *et al.*, 2010; Sun, 2010; Chu & Lin, 2009). The TOPSIS method was developed by Hwang and Yoon (1981) and is based on the concept that the chosen alternative should have the shortest distance from the positive ideal solution (PIS) and the farthest from the negative ideal solution (NIS). The FTOPSIS method variant can be summarized as follows: (i) obtain the weighting of criteria from fuzzy AHP. The results of fuzzy AHP contain the weights of each criterion and sub-criterion under consideration; (ii) create fuzzy evaluation matrices. A set of fuzzy linguistic terms are employed for the calculation of the outcomes; (iii) normalize fuzzy decision matrices; (iv) determine the fuzzy positive ideal and fuzzy negative ideal reference points. Fuzzy positive ideal solution (FPIS) and fuzzy negative ideal solution (FNIS) are defined by the area compensation technique; (v) identify the distance from FPIS (d+) and FNIS (d-); (vi) determine the relative closeness to the ideal value and rank alternatives accordingly.

RESEARCH METHODOLOGY

The methodology adopted in the present research encompasses the following steps: first, as mentioned before, a literature review covered the main sources of peer-reviewed scientific articles, such as Scopus; Web of Science; and Science Direct (2006 - 2016). Additionally, Google Scholar was accessed to complement the search results.

The analysis of current state of research on the main subjects of this work – ‘assessment and selection of renewable energy technologies’ and ‘fuzzy MCDM methods’ – led to the identification of research gaps and unsolved problems focusing on the intersection belonging to both subjects. Second, formal modelling was used to develop an integrated fuzzy MCDM approach for assessing and selecting renewable energy technologies in different energy planning contexts (national, regional, or local).

Third, an empirical study concerning energy planning in the State of Rio de Janeiro (Brazil) was carried out to validate the model, and to detect opportunities and limitations of the proposed model. The research can be considered applied, descriptive, and methodological. The results highlight the selection of the most appropriate technologies according to their environmental, social, economic, technical, and political impacts and could demonstrate the applicability of the proposed mode through a real case of renewable energy planning. In the case of the State of Rio de Janeiro, given the potential of renewable sources and respective impacts in this region the most appropriate technology was solar photovoltaic.

THE FUZZY-AHP-TOPSIS MODEL FOR ASSESSING RENEWABLE ENERGY TECHNOLOGIES

technologies. Figure 1 shows the flow chart of the model in two phases: (i) in the first phase, the Fuzzy AHP method is used for weighting criteria and subcriteria concerning assessment of the renewable energy technologies; (ii) in the second, the Fuzzy TOPSIS is employed for ranking the renewable energy technologies by their multiple objectives. Further, this model was validated by an empirical study covering the state of Rio de Janeiro in Brazil.

Figure 1: Flow chart of the Fuzzy AHP-TOPSIS model for assessment renewable energy technologies

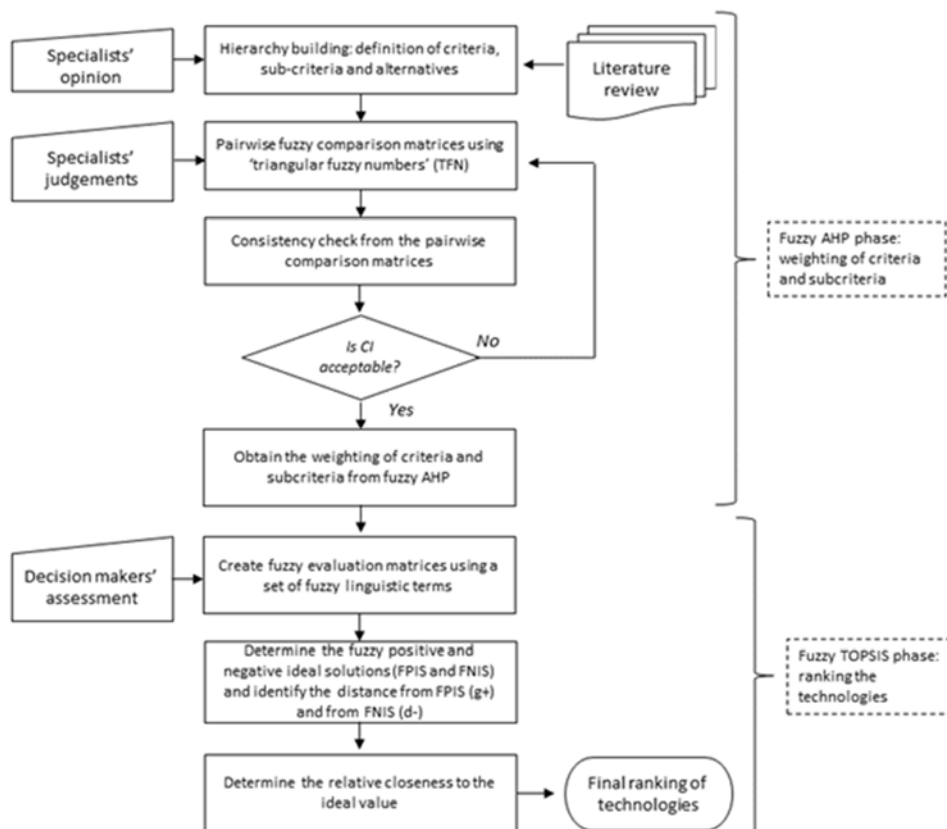

Due to space limitations, we will not be able to give a comprehensive description of each phase. Detailed descriptions of fuzzy AHP and fuzzy TOPSIS are already published and can be found in Torfi *et al.* (2010).

MODEL VALIDATION

To demonstrate the applicability and effectiveness of the proposed model, we develop an empirical study concerning energy planning in the State of Rio de Janeiro (Brazil), from the perspective of increasing the share of renewable sources in the energy matrix of this State (in response to the Brazilian policy of diversification of energy supply and production).

Brazil has the world's highest production of energy derived from renewables (39.4%), compared to an average of less than 20% for the rest of the world. Besides, during COP21 Brazil committed to avoiding the risks of climate change and increasing renewable energy up to 20% of total requirements by 2030. The country has set a target of reducing greenhouse gases 37% by 2025 and 43% by 2030 (Federative Republic of Brazil, 2015).

Almost 90% of Brazilian electricity was generated from renewable sources. Brazil is a leading nation regarding centralized generation of electrical power using renewable energy sources and has a clear national strategy that involves increasing renewable energy capacity (Federative Republic of Brazil, 2015). In the State of Rio de Janeiro, several sources of electricity generation have been explored. The nominal capacity of conventional thermoelectric plants is 5,165 MW, followed by thermonuclear plants with 1,990 MW. Among the renewable sources, hydroelectric occupies third place overall, with a total of 1,263 MW of nominal capacity. The State of Rio de Janeiro has an area of 43.8 thousand m² and its population reached 16.6 million in 2016. The electricity consumption registered in 2014 was 54,850 GWh (IBGE, 2016; Governo do Estado do Rio de Janeiro, 2015).

From the power matrix of the State of Rio de Janeiro, we selected five renewable energy technologies, as follows: (i) hydropower; (ii) photovoltaic (PV); (iii) wind; (iv) biomass; and (v) wave. These alternative renewable sources were chosen in function of their potential availability in the State, as shown in Table 2.

Table 2: Potential installed capacity of energy plants from renewable sources

Renewable source	Potential installed capacity in MW	References
Hydropower	570.8	INEA (2014)
Photovoltaic	2,685	EPE (2016)
Wind	1,524 - 2,813	Amarante <i>et al.</i> (2002)
Biomass	35 - 70 - 93	USP (2012)
Wave	9,800	EPE (2016)

Data Collection and Analysis

Two workshops with specialists in renewable energy technologies were carried out with the following objectives: (i) to collect expert judgments for fulfilling six criteria and subcriteria AHP matrices (Tables 4, 5, 6, 7, 8 and 9). The scale used to capture the linguistic imprecision in a pairwise comparison of criteria and subcriteria was the fuzzified Saaty's 9-point scale, by adopting 'triangular fuzzy numbers' (TFN); and (ii) to collect expert judgements concerning the assessment of renewable energy technologies, based on criteria/subcriteria and respective weights (by using the Fuzzy TOPSIS tool for data collection).

During the analysis phase, the data were consolidated and evaluated by using the fuzzy AHP-TOPSIS model. The individual steps from the fuzzy AHP matrices and the weighted vectors to the final ranking of renewable energy technologies (using fuzzy TOPSIS) were implemented with the support of Matlab® to test to what extent the model could be integrated into the available standard software.

Empirical Results

Step 1: Hierarchy building: definition of criteria, sub-criteria, and alternatives

The problem was formulated as the fulfillment of five criteria (corresponding to sustainable dimensions); and nine sub-criteria (referred to themes associated with these dimensions, as described in Table 3).

Table 3: Hierarchy building: definition of criteria and sub-criteria

Criteria	Sub-criteria
Technical	c1 - Efficiency
	c2 -Technology maturity
	c3 - Resource availability
	c4 - Reliability of energy supply
	c5 - Ease of decentralization
	c6 - Simplicity
Environmental	c7 - Greenhouse gas emissions
	c8 - Land use
	c9 - Compliance with local natural conditions
	c10 - Water use
	c11 - Treatment of waste
Economic	c12 - Levelized energy cost
	c13 - Payback period
	c14 - Investment risk
Social	c15 - Job creation
	c16 - Social acceptability
	c17 - Energy system safety
	c18 - Influence on sustainable development of society
Political	c19 - Compliance with international obligations
	c20 - Compliance with national policies
	c21 - Legal regulation of activities
5 criteria	21 sub-criteria

Step 2: Pairwise fuzzy comparison matrices using ‘triangular fuzzy numbers’ (TFN)

A pairwise fuzzy comparison matrix \tilde{A} was built according to the judgments of specialists in renewable energy technologies, according to Eq. (1).

$$\tilde{A} = \begin{bmatrix} \tilde{I}_{11} & \tilde{a}_{12} & \dots & \tilde{a}_{1n} \\ \tilde{a}_{21} & \tilde{I}_{22} & \dots & \tilde{a}_{2n} \\ \vdots & \vdots & \ddots & \vdots \\ \tilde{a}_{n1} & \tilde{a}_{n2} & \dots & \tilde{I}_{nn} \end{bmatrix} \quad (1)$$

Whereas $\tilde{a}_{ij} = (1,1,1)$, if i equals to j and \tilde{a}_{ij} assumes the fuzzified Saaty’s 9-point scale (by adopting ‘triangular fuzzy numbers’), or their inverse values, when i is not equal to j . Converses values are computed from the rating given, where \tilde{A}_{ij} is the matrix of values pointed to the relationship pairwise, then \tilde{A}_{ji} equals $1 / \tilde{A}_{ji}$. For this empirical study, we built in a total of six fuzzy comparison matrices: one for criteria e five more for the respective subcriteria, as shown in the Tables 4, 5, 6, 7, 8 and 9.

Table 4: Fuzzy Comparison Matrix for Criteria

Criteria	Environmental	Economic	Political	Social	Technical
Environmental	(1; 1; 1)	(0,2; 0,25; 0,33)	(1; 1; 2)	(1; 2; 3)	(0,17; 0,2; 0,25)
Economic	(3; 4; 5)	(1; 1; 1)	(3; 4; 5)	(3; 4; 5)	(1; 2; 3)
Political	(0,5; 1; 1)	(0,2; 0,25; 0,33)	(1; 1; 1)	(0,33; 0,5; 1)	(0,2; 0,25; 0,33)
Social	(0,33; 0,5; 1)	(0,2; 0,25; 0,33)	(1; 2; 3)	(1; 1; 1)	(0,25; 0,33; 0,33)
Technical	(4; 5; 6)	(0,33; 0,5; 1)	(3; 4; 5)	(3; 3; 4)	(1; 1; 1)

Table 5: Fuzzy Comparison Matrix for Criterion ‘Technical’

Sub-criteria	c4	c6	c3	c2	c1	c5
c4	(1; 1; 1)	(2; 3; 4)	(0,33; 0,5; 1)	(1; 1; 2)	(3; 3; 3)	(2; 3; 4)
c6	(0,25; 0,33; 0,5)	(1; 1; 1)	(0,25; 0,33; 0,5)	(0,33; 0,5; 1)	(1; 2; 3)	(0,5; 0,5; 1)
c3	(1; 2; 3)	(2; 3; 4)	(1; 1; 1)	(1; 2; 3)	(1; 2; 3)	(1; 2; 3)
c2	(0,5; 1; 1)	(1; 2; 3)	(0,33; 0,5; 1)	(1; 1; 1)	(2; 3; 4)	(1; 2; 3)
c1	(0,33; 0,33; 0,33)	(0,33; 0,5; 1)	(0,33; 0,5; 1)	(0,25; 0,33; 0,5)	(1; 1; 1)	(1; 1; 3)
c5	(0,25; 0,33; 0,5)	(1; 2; 2)	(0,33; 0,5; 1)	(0,33; 0,5; 1)	(0,33; 1; 1)	(1; 1; 1)

Table 6: Fuzzy Comparison Matrix for Criterion ‘Environmental’

Sub-criteria	c7	c9	c8	c10	c11
c7	(1; 1; 1)	(2; 3; 3)	(1; 2; 3)	(1; 2; 3)	(1; 2; 3)
c9	(0,33; 0,33; 0,5)	(1; 1; 1)	(1; 1; 2)	(1; 1; 2)	(1; 1; 2)
c8	(0,33; 0,5; 1)	(0,5; 1; 1)	(1; 1; 1)	(1; 1; 2)	(1; 2; 3)
c10	(0,33; 0,5; 1)	(0,5; 1; 1)	(0,5; 1; 1)	(1; 1; 1)	(1; 2; 3)
c11	(0,33; 0,5; 1)	(0,5; 1; 1)	(0,33; 0,5; 1)	(0,33; 0,5; 1)	(1; 1; 1)

Table 7: Fuzzy Comparison Matrix for Criterion ‘Economic’

Sub-criteria	c12	c13	c14
c12	(1; 1; 1)	(1; 1; 2)	(1; 2; 3)
c13	(0,5; 1; 1)	(1; 1; 1)	(0,5; 0,5; 1)
c14	(0,33; 0,5; 1)	(1; 2; 2)	(1; 1; 1)

Table 8: Fuzzy Comparison Matrix for Criterion ‘Political’

Sub-criteria	c19	c20	c21
c19	(1; 1; 1)	(1; 1; 1)	(2; 2; 3)
c20	(1; 1; 1)	(1; 1; 1)	(1; 2; 3)
c21	(0,33; 0,5; 0,5)	(0,33; 0,5; 1)	(1; 1; 1)

Table 9: Fuzzy Comparison Matrix for Criterion ‘Social’

Sub-criteria	c15	c16	c17	c18
c15	(1; 1; 1)	(1; 2; 3)	(1; 2; 3)	(0,5; 1; 1)
c16	(0,33; 0,5; 1)	(1; 1; 1)	(0,33; 0,5; 1)	(0,33; 0,5; 1)
c17	(0,33; 0,5; 1)	(1; 2; 3)	(1; 1; 1)	(0,33; 0,5; 1)
c18	(1; 1; 2)	(1; 2; 3)	(1; 2; 3)	(1; 1; 1)

Step 3: Consistency check from the pairwise comparison matrices

One benefit of fuzzy AHP is that coherence of the matrices can be tested during the judgment process. When the crisp comparison matrix A is consistent, it means that the fuzzy comparison matrix \tilde{A} is also consistent. The Consistency Ratio (CR) is used to estimate the consistency of pairwise comparisons, and can be calculated by (2):

$$CR = \frac{CI}{RI}, \text{ where the Consistency Index is } CI = \frac{\lambda_{max} - n}{n-1}, \text{ then } \lambda_{max} \text{ is the largest eigenvalue} \quad (2)$$

and the Random Consistency Index (RI) is shown below, being n the matrix size.

Size n	1	2	3	4	5	6	7	8
RI	0	0	0.52	0.89	1.11	1.25	1.35	1.40

In general, when $CR \leq 0,10$, the consistency is accepted. If the CI is not accepted, it is necessary to review the judgments by specialists. In this empirical study, all six matrices showed good and allowed consistency indexes, validating the method FAHP for weighting the criteria and sub-criteria (Table 10).

Table 10: Consistency Ratio (CR) for criteria and sub-criteria

Criteria and sub-criteria	Consistency Ratio (CR)	Status $CR \leq 0.1$
Criteria (Environmental; Economic; Political; Social; Technical)	0.056	OK. Consistent.
Technical	0.046	OK. Consistent.
Environmental	0.022	OK. Consistent.
Economic	0.000	OK. Consistent.
Social	0.023	OK. Consistent.
Political	0.000	OK. Consistent.

Step 4: Obtain the weighting of criteria and sub-criteria from fuzzy AHP

The weights, commonly called priority vectors (W), can be expressed by $\tilde{W}^T = (\tilde{w}_1^T, \tilde{w}_2^T, \dots, \tilde{w}_n^T)$. They were calculated as the geometric mean of each row of the pairwise comparison matrices and implemented in the Matlab®. The output of this program provided the fuzzy vector normalized weights (Table 11). Furtherly, to consider the weights of the criteria and sub-criteria, we calculated an ‘Overall Fuzzy Weight’ for each subcriteria by (3), as shown in Table 5.

Table 11: The normalized fuzzy weights of criteria and sub-criteria from fuzzy AHP

Technical	Environmental	Economic	Social	Political
(0.1623; 0.3319; 0.818)	(0.0183; 0.0496; 0.1041)	(0.2133; 0.5383; 1.1959)	(0.0181; 0.0465; 0.1142)	(0.0168; 0.0336; 0.0998)

Table 12: Overall fuzzy weights for sub-criteria

Technical	c1	(0.012; 0.033; 0.19)	Economic	c12	(0.245; 0.413; 0.783)
	c2	(0.04; 0.201; 0.793)		c13	(0.155; 0.26; 0.431)
	c3	(0.072; 0.401; 1.649)		c14	(0.17; 0.328; 0.543)
	c4	(0.091; 0.263; 1.099)	Social	c15	(0.111; 0.355; 0.8)
	c5	(0.012; 0.061; 0.24)		c16	(0.046; 0.112; 0.384)
	c6	(0.013; 0.042; 0.218)		c17	(0.067; 0.178; 0.554)
Environmental	c7	(0.124; 0.475; 1.354)	Political	c18	(0.14; 0.355; 1.008)
	c8	(0.054; 0.165; 0.568)		c19	(0.133; 0.25; 0.318)
	c9	(0.068; 0.114; 0.497)		c20	(0.167; 0.25; 0.318)
	c10	(0.043; 0.165; 0.451)		c21	(0.305; 0.5; 0.832)
	c11	(0.026; 0.082; 0.313)			

The following results correspond to the validation of the second phase of the model. The fuzzy TOPSIS method was employed for ranking SMEs by their innovative capacity.

Step 5: Create fuzzy evaluation matrices using a set of fuzzy linguistic terms

Fuzzy evaluation matrices were created by using fuzzy numerical linguistic terms generated from the decision makers' assessment. The fuzzy decision matrices \tilde{D} were constructed by (3), as follows:

$$\tilde{D} = \begin{matrix} E_1 \\ E_2 \\ \vdots \\ E_m \end{matrix} \begin{bmatrix} \tilde{x}_{11} & \tilde{x}_{12} & \dots & \tilde{x}_{1n} \\ \tilde{x}_{21} & \tilde{x}_{22} & \dots & \tilde{x}_{2n} \\ \vdots & \vdots & \ddots & \vdots \\ \tilde{x}_{m1} & \tilde{x}_{m2} & \dots & \tilde{x}_{mn} \end{bmatrix}, i = 1, 2, \dots, m; j = 1, 2, \dots, n \quad (3)$$

Furtherly, normalized fuzzy decision matrices \tilde{R}_{ij} were generated by using a linear normalization to convert the scales, as shown bellow (4):

$$\tilde{R}_{ij} = [\tilde{r}_{ij}]_{m \times n}, i = 1, 2, \dots, m; j = 1, 2, \dots, n.$$

Where $\tilde{r}_{ij} = \left(\frac{a_{1ij}}{a_{3j}^+}, \frac{a_{2ij}}{a_{3j}^+}, \frac{a_{3ij}}{a_{3j}^+} \right) i = 1, 2, \dots, m$ (4)

$$c_j^+ = \max_i c_{ij}^{a_2, a_3}$$

$$c_j^- = \min_i c_{ij}^{a_1}$$

The c_j^+ is the maximum value of c_j^* for each sub-criteria, used when the values are in medium (a_2) and upper (a_3) position in the fuzzy number, and the c_j^- is the minimum value of c_j^* are used in the lower (a_1) value of the fuzzy number.

Once the normalized fuzzy matrices were built, the weights found by Fuzzy-AHP (Table 5) were applied and assigned to new matrix \tilde{V} (5).

$$\tilde{V} = [\tilde{v}_{ij}]_{m \times n}, i = 1, 2, \dots, m; j = 1, 2, \dots, n,$$

where $\tilde{v}_{ij} = (\tilde{v}_{ij}^{a_1}, \tilde{v}_{ij}^{a_2}, \tilde{v}_{ij}^{a_3}) = w_j \otimes \tilde{r}_{ij} = (w_j^{a_1} \tilde{r}_{ij}^{a_1}, w_j^{a_2} \tilde{r}_{ij}^{a_2}, w_j^{a_3} \tilde{r}_{ij}^{a_3})$. (5)

Step 6: Determining the fuzzy positive and negative ideal solutions (FPIS and FNIS) and identify the distance from FPIS (d+) and FNIS (d-)

In this step, we calculated the Euclidian distance, considering the normalized fuzzy weighted values yielded from step 5. Additionally, the fuzzy positive-ideal solution (FPIS) and fuzzy negative-ideal solution (FNIS) could also be determined. Two new matrices denoted by V^+ and V^- were calculated according to the Euclidean distance to the ideal fuzzy positive solution (FPIS), \tilde{v}_j^* , and the ideal fuzzy negative solution (FNIS), \tilde{v}_j^- , respectively (6).

$$\tilde{V}^+ = d(\tilde{v}_{ij}, \tilde{v}_j^*), \text{ where } \tilde{v}_j^* = (\max\{\tilde{v}_{ij}^{a_1}\}, \max\{\tilde{v}_{ij}^{a_2}\}, \max\{\tilde{v}_{ij}^{a_3}\}), j = 1, 2, \dots, n \quad (6)$$

$$\tilde{V}^- = d(\tilde{v}_{ij}, \tilde{v}_j^-), \text{ where } \tilde{v}_j^- = (\min\{\tilde{v}_{ij}^{a_1}\}, \min\{\tilde{v}_{ij}^{a_2}\}, \min\{\tilde{v}_{ij}^{a_3}\}), j = 1, 2, \dots, n$$

Finally, the Euclidean distances were summed and two vectors D^+ and D^- were established by (7).

$$D^+ = \sum_{j=1}^n d(\tilde{v}_{ij}, \tilde{v}_j^+), i = 1, 2, \dots, m \text{ and } D^- = \sum_{j=1}^n d(\tilde{v}_{ij}, \tilde{v}_j^-), i = 1, 2, \dots, m \quad (7)$$

Steps 7 and 8: Determine the relative closeness to the ideal value and final ranking of SMEs by innovative capacity

The ‘Closeness Coefficient’ (CC_i) is a relative closeness to the fuzzy positive and negative ideal solution, and can be calculated by (8):

$$CC_i = \frac{D_i^-}{D_i^- + D_i^+} \quad (8)$$

From the resulting ‘Closeness Coefficients’ and considering the same basis for all renewable energy technologies, a final ranking of the technologies was achieved. The relative closeness to the ideal value and final ranking of the technologies are presented in Table 13.

Table 13: Distances, Closeness Coefficients (CC_i) and final ranking of the renewable energy technologies

Technologies	Distances		CC_i	
	D+	D-	Score	Position
Hydropower	16.546	10.036	0.378	3
Solar PV	16.278	11.022	0.404	1
Wind	16.344	10.517	0.392	2
Biomass	16.825	9.300	0.356	4
Wave	16.795	8.902	0.346	5

The highest ‘Closeness Coefficients’ (CC_i) indicates that photovoltaics (0.404) and the wind technology (0.392) are closer to the ideal solution than the remaining technologies. The worst result refers to wave energy, with CC_i 0.346.

Managerial and Policy Implications

The results presented in this section indicate that the fuzzy AHP-TOPSIS model is a consistent multicriteria analysis tool, which allows management practitioners and policy makers to process data related to various dimensions generating an overall assessment result. Added to this, the possibility of entering data with a high level of dispersion makes the method more reliable in the case of CO₂ emissions. By way of illustration, if only the mean value of CO₂ emissions were used in renewable energy analysis, this could be considered less credible, considering that emissions from wind technology, for example, have an estimated average of 34.2 gCO₂ eq / kWh, with values ranging from 8 to 124 gCO₂ eq / kWh.

The model considered the hierarchical and multidimensional structure of the focused renewable energy analysis, allowing experts to assign weights, according to the importance of each criterion/sub-criterion previously defined. The model also considered the complexity, subjectivity, and uncertainty, being these characteristics inherent to the process of assessing and selecting renewable energy technologies in different energy planning contexts (national, regional, or local). Therefore, the findings from this study are expected to be very useful for management practitioners and policy makers.

CONCLUDING REMARKS

In general, empirical studies on multi-criteria applications in renewable energy analysis have shown that in real situations when the evaluation ratings are vague and imprecise fuzzy MCDM models can be the preferred solution. Especially, for the selection of renewable energy technologies, vagueness and uncertainty exist in determining the level of perceived effectiveness of a given technology to mitigate the risks associated with human-induced global warming and to increase the presence of renewable energies in the national or the local energy matrix.

In this paper, an attempt was made to demonstrate in practice the benefits of adopting a fuzzy AHP-TOPSIS approach, once the decision-making processes regarding the choice of renewable energy technologies can be

characterized by subjectivity, uncertainty, and ambiguity. Due to such characteristics, multi-criteria decision making (MCDM) methods combined with fuzzy logic proved to be an adequate methodological approach for assessing and selecting technologies. The results highlight the selection of the most appropriate technologies according to their environmental, social, economic, technical, and political impacts and the applicability of the proposed model focusing the energy planning of the State of Rio de Janeiro. In this case, given the potential of renewable sources and respective impacts in this region the most appropriate technology was solar photovoltaic.

For future research works and deepening of the results presented in this paper, we suggest the following lines:

- i. Application of the model in other regions, to compare the results of the case of State of Rio de Janeiro with these new findings, highlighting the differences that could arise;
- ii. Elaboration and comparison of new hybrid methods integrating fuzzy logic and multicriteria methods like fuzzy ELECTRE, PROMETHEE, VIKOR, among others;
- iii. Investigation on the use of different pertinence functions such as trapezoidal and Gaussian, instead of Triangular Fuzzy Numbers (TFN).

REFERENCES

- Abu Taha, R.; Daim, T. (2013). Multi-Criteria Applications in Renewable Energy Analysis. A Literature Review. In: Daim, T. *et al.* (Eds.) *Research and Technology Management in the Electricity Industry: Methods, Tools, and Case Studies*. P. 17-30, Springer-Verlag, London.
- Al Garni, H., Kassem, A., Awasthi, A., Komljenovic, D., & Al-Haddad, K. (2016). A Multicriteria Decision Making Approach for Evaluating Renewable Power Generation Sources in Saudi Arabia. *Sustainable Energy Technologies and Assessments*, 16, 137-150.
- Amarante, O. A. C. D. *et al.* (2002). *Atlas Eólico do Estado do Rio de Janeiro*. Governo do Estado do Rio de Janeiro, Rio de Janeiro
- Amponsah, N. Y. *et al.* (2014). Greenhouse Gas Emissions from Renewable Energy Sources: A Review of Lifecycle Considerations. *Renewable and Sustainable Energy Reviews*, 39, 461–475.
- Arçer, M. E. *et al.* (2015). The Use of Grey-based Methods in Multi-criteria Decision Analysis for the Evaluation of Sustainable Energy Systems: A Review. *Renewable and Sustainable Energy Reviews*, 47, 924-932.
- Burton, J., Hubacek, K. (2007). Is Small Beautiful? A Multicriteria Assessment of Small-Scale Energy Technology Applications in Local Governments. *Energy Policy*, 35 (12), 6402–6412.
- Carrera, D. G., Mack, A. (2010). Sustainability Assessment of Energy Technologies via Social Indicators: Results of a Survey among European Energy Experts. *Energy Policy*, 38, 1030-1039.
- Chatzimouratidis A I, Pilavachi P A. (2008). Sensitivity Analysis of the Evaluation of Power Plants Impact on the Living Standard using the Analytic Hierarchy Process. *Energy Conversion and Management*, 49 (12), 3599–3611.
- Chu, T., Lin, Y. (2009). An Interval Arithmetic based Fuzzy TOPSIS Model. *Expert Systems with Applications*, 36 (8), 10870–10876.
- Diakoulaki, D., Karangelis, F. (2007). Multi-Criteria Decision Analysis and Cost–benefit Analysis of Alternative Scenarios for the Power Generation Sector in Greece. *Renewable & Sustainable Energy Reviews*, 11 (4), 716–27.
- EPE (2016). *Energia renovável: hidráulica, biomassa, eólica, solar, oceânica*. Empresa de Pesquisa Energética. Brasília.

Ertay, T., Kahraman, C., & Kaya, I. (2013). Evaluation of Renewable Energy Alternatives using MACBETH and Fuzzy AHP Multicriteria Methods: the Case of Turkey. *Technological and Economic Development of Economy*, 19 (1), 38–62.

Federative Republic of Brazil. (2015). Intended Nationally Determined Contribution towards Achieving the Objective of the United Nations Framework Convention on Climate Change. Available in <http://www.itamaraty.gov.br/en/ficha-pais/11919-contribuicao-brasil-indc-27-de-setembro-2>. Accessed 21 March 2017.

Georgopoulou, E., Lalas, D., & Papagiannakis, L. (1997). A Multicriteria Decision Aid Approach for Energy Planning Problems: The Case of Renewable Energy Option. *European Journal of Operational Research*, 103, 38-54.

Governo do Estado do Rio de Janeiro (2015). Secretaria de Desenvolvimento, Energia, Indústria e Serviços. *Balanco Energético do Estado do Rio de Janeiro 2014*. SEDEIS, Rio de Janeiro.

Hadian, S., Madani, K. (2015). A System of Systems Approach to Energy Sustainability Assessment: Are all Renewables Really Green?. *Ecological Indicators*, 52, 194-206, 2015.

Hwang, C.L., Yoon, K. (1981). *Multiple Attributes Decision Making Methods and Applications*. Berlin: Springer.
Instituto Brasileiro de Geografia e Estatística (2016). *Estados@, 2016*. Available in <http://www.ibge.gov.br>. Accessed 15 April 2017.

INEA (2014). *RT-05 - Aproveitamentos hidrelétricos no Estado do Rio de Janeiro*. Governo do Estado do Rio de Janeiro, Rio de Janeiro.

Kaya, T., Kahraman, C. (2010). Multicriteria Renewable Energy Planning using an Integrated Fuzzy VIKOR and AHP Methodology: The Case of Istanbul. *Energy*, 35, 2517-2527.

Lee, S.K. *et al.* (2009). Decision Support for Prioritizing Energy Technologies against High Oil Prices: A Fuzzy Analytic Hierarchy Process Approach. *Journal of Loss Prevention in the Process Industries*, 22, 915–920.

Liu, G. (2014). Development of a General Sustainability Indicator for Renewable Energy Systems: A Review. *Renewable and Sustainable Energy Reviews*, 31, 611-621.

Mardani, A. *et al.* (2015). Fuzzy Multiple Criteria Decision-making Techniques and Applications – Two Decades Review from 1994 to 2014. *Expert Systems with Applications*, 42, 4126–4148.

Mourmouris, J. C., Potolias, C. (2013). A Multi-criteria Methodology for Energy Planning and Developing Renewable Energy Sources at a Regional Level: A Case Study of Thassos, Greece. *Energy Policy*, 52, 522-530.

Oberschmidt, J. *et al.* (2010). Modified PROMETHEE Approach for Assessing Energy Technologies. *International Journal of Energy Sector Management*, 4, 183–212.

Pohekar, S.D., Ramachandran, M. (2004). Application of Multi-criteria Decision-Making to Sustainable Energy Planning – a Review. *Renewable & Sustainable Energy Reviews*, 8, 365–381.

Polatidis, H. *et al.* (2006). Selecting an Appropriate Multi-criteria Decision Analysis Technique for Renewable Energy Planning. *Energy Sources*. Part B, 1, 181–193.

Purwanto, W.W. *et al.* (2015). Multi-Objective Optimization Model for Sustainable Indonesian Electricity System: Analysis of Economic, Environment, and Adequacy of Energy Sources. *Renewable Energy*, 81, 308–18.

Rahman, M.M., Paatero, J.V., Lahdelma R, & Wahid, M.A. (2016). Multicriteria-Based Decision Aiding Technique for Assessing Energy Policy Elements: Demonstration to a Case in Bangladesh. *Applied Energy*, 164, 237–44.

- REN21. Renewable Energy Policy Network for the 21st Century (2012). *Renewables 2012. Global Status Report*. REN21 Secretariat, Paris.
- Ribeiro F., Ferreira, P., & Araújo, M. (2013). Evaluating Future Scenarios for the Power Generation Sector using a Multi-Criteria Decision Analysis (MCDA) Tool: the Portuguese case. *Energy*, 52, 126–36.
- Saaty, T. L. (1980). *The Analytic Hierarchy Process*. McGraw-Hill, New York.
- Santoyo-Castelazo, E., Azapagic, A. (2014). Sustainability Assessment of Energy Systems: Integrating Environmental, Economic and Social Aspects. *Journal of Cleaner Production*, 80, 119-138.
- Şengül, Ü. *et al.* (2015). Fuzzy TOPSIS Method for Ranking Renewable Energy Supply Systems in Turkey. *Renewable Energy*, 75, 617-625.
- Shahrabi, M. (2014). Identification and Selection of Robot using FAHP and FTOPSIS Hybrid Model. *International Journal of Modern Engineering Sciences*, 3(1), 16-28.
- Shmelev, S. E., Van Den Bergh, J. C. J. M. (2016). Optimal Diversity of Renewable Energy Alternatives under Multiple Criteria: An Application to the UK. *Renewable and Sustainable Energy Reviews*, 60, 679-691.
- Stein, E. W. (2013). A Comprehensive Multi-Criteria Model to Rank Electric Energy Production Technologies. *Renewable and Sustainable Energy Reviews*, 22, 640-654.
- Štreimikienė, D., Šliogerienė, J., & Turskis, Z. (2016). Multi-Criteria Analysis of Electricity Generation Technologies in Lithuania. *Renewable Energy*, 85, 148-156.
- Sun, C.-C. (2010). A Performance Evaluation Model by Integrating Fuzzy AHP and Fuzzy TOPSIS Methods. *Expert Systems with Applications*, 37, 7745–7754.
- Taylan, O. *et al.* (2016). An Integrated Multi-Attribute Decision Model for Energy Efficiency Processes in Petrochemical Industry Applying Fuzzy Set Theory. *Energy Conversion and Management*, 117 (2016), 501–512.
- Torfi, F., Farahani, R.Z., & Rezapour, S. (2010). Fuzzy AHP to Determine the Relative Weights of Evaluation Criteria and Fuzzy TOPSIS to Rank the Alternatives. *Applied Soft Computing*, 10, 520–528.
- Troldborg, M., Heslop, S., & Hough, R. L. (2014). Assessing the Sustainability of Renewable Energy Technologies using Multi-criteria Analysis: Suitability of Approach for National-scale Assessments and Associated Uncertainties. *Renewable and Sustainable Energy Reviews*, v.39, p. 1173–1184.
- USP. Grupo de Pesquisa em Bioenergia - GBIO (2012). *Atlas de Biomassa*. Available in <http://www.iee.usp.br>. Accessed 17 March 2017
- Wang J–J. *et al.* (2009). Review on Multi-criteria Decision Analysis Aid in Sustainable Energy Decision-making. *Renewable and Sustainable Energy Reviews*, 13, 2263–2278.
- Wittstruck, D., Teuteberg, F. (2012). Integrating the Concept of Sustainability into the Partner Selection Process: a Fuzzy-AHP-TOPSIS Approach. *International Journal of Logistics Systems and Management*, 12(2), 195 – 226.
- Yager, R.R. (1977). Fuzzy Decision Making Including Unequal Objectives. *Fuzzy Sets and System*, 1, 87-95.
- Yang, C., Qiang, Z., & Shuai, D. (2015). An Evaluation Method for Innovation Capability Based on Uncertain Linguistic Variables. *Applied Mathematics and Computation*, 256, 160 –174.
- Zadeh, L.A. (1965). Fuzzy Set. *Information and Control*, 18, 338-353.

Zadeh, L.A. (1973). Outline of a New Approach to the Analysis of Complex Systems and Decision Processes. *IEEE Transactions on Systems, Man, and Cybernetics*, SMC-3 (1), 28-44.

Zhou, P. *et al.* (2006). Decision Analysis in Energy and Environmental Modeling: an update. *Energy*, 31, 2604–2622.

THE PROTECTION OF AN ‘EMPLOYEE’ WHOSE CONTRACT IS TERMINATED BEFORE COMMENCEMENT OF WORK IN SOUTH AFRICAN LAW

Jamwell Maswanganyi, Tshwane University of Technology, South Africa

ABSTRACT

One of the most controversial questions in South African employment law is the status of a person who has been offered a job, but whose offer of employment is terminated before the person starts working. This raises a number of questions, including whether this person is in fact an employee, even before the person commences employment. It raises a further, and related, question as to the sort of claim (or a dispute in a labour context) the person can launch. Can the person be allowed to claim dismissal and unfair labour practice disputes, or can the person only be allowed to claim a breach of contract (assuming the facts establish the existence of a contract). The old section 186 (1) (a) of the Labour Relations Act 66 of 1995 (herein referred to as the ‘old labour position’), before its amendment via the Labour Relations Amendment Act, 2014 (the Amended Position), was confronted with this controversy. The courts, despite initial divergence on the point, finally resolved the issue (or at least part of the issue) by ruling that a person could claim to have been dismissed even before he or she starts working. Some of the controversies are likely to continue under the Amended Position. This paper seeks to examine the various laws, including case law, dealing with the protection of persons whose contracts are terminated before they commence work. The paper, in the process, contrasts the position under the old labour position with that under the Amended Position. The paper argues for more legislative clarity on the issue, so as to dispel speculation.

Keywords: Dismissal, Contract of employment, Work, Employee, employment.

INTRODUCTION

Employees are often offered employment and told to commence work at a later date, but later told that they are no longer needed. This created controversies in terms of the old section 186 (1) (a) of the Labour Relations Act 66 of 1995 (LRA) (the pre-amendment position is sometimes hereinafter referred to as the ‘Old Labour Position’), before the Labour Relations Amendment Act, 2014 (the post-amendment position is sometimes hereinafter referred to as the ‘Amended Position’) came into operation in 2015. The controversies (or at least some of them) are likely to continue under the Amended position. Before looking at the likely controversies under the Amended Position, a look at the Old Labour Position is necessary.

OLD LABOUR POSITION

A summary of the general meaning of dismissal in terms of the LRA

So as to place the law of dismissal in this area in proper context, it is necessary to briefly look at how the LRA before amendments dealt with the meaning of dismissal. Section 186 (1) (a) of the LRA defined dismissal as an employer’s termination of a contract of employment with or without notice. Section 186 (1) (b) of the LRA dealt with an employer’s non-renewal of a contract of fixed-term contract, where an employee reasonably expected a

renewal of the contract on the same or better terms (the provision also dealt with instances where the employer renewed the contract on less favourable terms than the previous contract provided).

Section 186 1 (c) dealt with the refusal by an employer to take back into employment an employee who was on maternity leave, if the maternity leave was taken in terms of the law. Section 186 1 (d) dealt with instances where an employer would dismiss a group of employees for the same or similar reasons, but later decides to re-employ some of the dismissed employees. In other words, the decision by the employer to selectively re-employ some of the dismissed employees constitutes a (fresh) dismissal of those not so re-employed. Section 186 1 (e) considered as dismissal the decision by an employee to resign from employment, if the resignation took place when the employee was facing intolerable conditions caused by the employer. This is usually referred to as a constructive dismissal. Section 186 1 (f) dealt with a situation where an employee resigns from employment because as a result of a transfer of contract of employment from one employer to another employer, the new employer provides the employee with conditions that are substantially less favourable than those the employee enjoyed before the transfer. This kind of termination of employment is also referred to as a constructive dismissal.

What is new in the Amended Position? Not much appears to have changed substantially, but this could turn out to be misleading, as it remains unclear as to how the courts will interpret these changes. In brief the changes are as follows: Section 186 1 (a) now refers to an employer's termination of 'employment', as opposed to 'contract of employment'. While Section 186 (1)(b)(i) of the LRA after the amendments reads the same as the previous subsection 1(b) of the same section, the Amended Position adds a new dimension to the meaning of dismissal arising from fixed-term contracts. The Amended Position does not only expect renewal on the same or similar terms, but also retention of the employee on a permanent basis. This new position addresses one of the perennial problems around fixed-term contracts, namely, whether reasonable expectation in the context of section 186 also included reasonable expectation of permanent employment. Although before the amendments the courts took the position that the expectation was only limited to renewal on the same or similar terms, employees generally thought that it also included expectation of permanent employment.

Although their expectations are now at least partly met, through the creation of the option of both reasonable expectation of renewal or retention on a permanent basis, this could create some interpretation problems. When will one know that one can only claim reasonable expectation of permanent employment, or merely renewal on the same or similar terms? Perhaps the criteria in section 198B of the LRA could be used when deciding whether to insist on being employed on the same or similar terms as the previous contract, or to be employed permanently. These criteria used to determine whether a person should be kept on fixed-term contract after three months or not. One should take note however that at this stage the focus is on whether there is dismissal or not, and not on the fairness of such dismissal.

There does not appear to be any changes in the rest of the section 186 (1) that merits any discussion here, more especially in the context of dismissal of employees before they commence employment. While it remains unclear as to whether there could be circumstances where the problem of dismissal before commencement of employment could trigger any of the subsections in section 186 (1), it remains uncontroversial that it will, and often does, trigger section 186 (1) (a), whether in its current format, or in its previous format i.e. before the Amended Position. The discussion will therefore revolve around section 186 (1) (a) (both before and after the amendments and only touching on the other subsections of section 186 (1) when it remains necessary.

Examination of section 186 (1) (a) of the LRA (before the 2014 amendments)

As indicated earlier, the Old Labour Position considered it as dismissal for the employer to terminate the contract of an employee with or without notice (section 186 (1) (a) of the LRA). In a situation where a person was offered employment, and he or she accepted the offer, but later told that that he or she cannot be given the job, the issue arose as to whether the person was an employee, and therefore considered dismissed. That there is a contract of employment already is considered settled, as a valid contract can be concluded even if it is not reduced into writing.

The remaining question therefore is one whether the person was an employee, and therefore capable of being dismissed. A related question is one whether the conclusion of a contract of employment automatically renders one party the employer, and the other the employee, even if one party does not as yet work for the other. (It also raises further questions: the meaning of work: does work imply actually rendering services, or simply being available to work. If the latter only suffices, which I argue it does suffice, can it be said in the scenario here that the person who has been offered a job to start on a later date is available for work before that later date? (We should also take note of a situation where he is still contracted to another employer, which could not only make him unavailable to render the service, but could also possibly create the situation of dual employment if both the future and the current employer are treated as employers).

Answering this question, i.e. whether the person offered employment is an employee, and therefore capable of being dismissed even before he or she commences work, requires a look at the definition of an employee in terms of the LRA, which reads:

- (a) any person, excluding an independent contractor, who works for another person or for the State and who receives, or is entitled to receive, any remuneration; and
- (b) any other person who in any manner assists in carrying on or in conducting the business of an employer. (Section 213 of the Labour Relations Act)

Both the Basic Conditions of Employment Act 75 of 1997(BCEA) and the Employment Equity Act 55 of 1998 (EEA) have an identical definition (see section 1 of both BCEA and EEA). (One should note that section 9 of the EEA specifically extend the meaning of an employee to include applicants for a job, but only in the case of alleged discrimination as contemplated in sections 6, 7 and 8 of that Act. One should further note that the repealed Item 7 (2) (a) of the LRA, which was the main provision dealing with discrimination issues at the workplace before the coming into operation of the EEA, also had a similar provision including applicants for employment in the definition of employee, but only in relation to alleged discrimination disputes). In 2002 this definition was further augmented by section 200A of the Labour Relations Act and Section 83A of the Basic Conditions of Employment Act, which looked at factors to be used to determine whether a person is an employee or an independent contractor. This was just a codification of some of the factors previously developed by the courts (the discussion of these factors is however unnecessary here as it does not help answer the question before us).

Back to the definition of an employee in terms of section 213 of the LRA, it is necessary to unbundle the section:

'Any person, excluding an independent contractor, who works for another person...'

Can a person offered employment, but who has not commenced employment, be said to 'work' for the person offering him the employment? Is it by design that the section is formulated in the present rather than the future tense i.e. suggesting that the person must be somebody who currently 'works', rather than somebody who will work, for another? If this section is read disjunctively from other sections of the Act, it could suggest that the person must presently work, rather than intends working for another. However, if the section is read together with section 186 (1) (a) (as it was before the Amended Position), which, as already indicated, treats as dismissal the termination of contract of employment, the word 'work' could mean not actually rendering services, but being contractually attached to another organization for the purposes of rendering those services, even if it means rendering the services in the future. (There might be those who argue that the person must at least be available for work, but this will still make the person offered (or at least some of those offered) employment ineligible as an employee, if this criterion were to be used in isolation. Some of the people might still be contracted to other employers, and serving notice (or not even yet given notice), therefore making them unavailable for work to the future employer).

The submission that it only needs being contractually attached to the future employer, for the purposes of rendering services, could therefore help the situation. There must however be a legally grounded conceptual basis for such a proposition. This could be in the form of a deeming provision (or a legal fiction), i.e. you are simply deemed to be an employee, although you are in fact not. The person becomes an employee only for the purposes of pursuing his or her employment rights in terms of the labour laws. The legal fiction is only triggered in case of a

breach of employment contract. The person cannot claim to be an employee for any other purpose. (One should note a related question about whether the employer can also claim to be this person's employer before the person actually starts working. An answer to such a question might create complications that are outside the scope of this paper, save to say a legal fiction appropriate for dealing with the rights of the employer could also be created).

'Who receives or is entitled to receive remuneration (from another person)'

This element of the definition is just an extension of the earlier element, rather than an alternative to it, hence the word 'and' just before the phrase 'who receives...'. The person offered employment cannot be said to receive remuneration, within the period before he starts working. Nor can he be said to be entitled to any remuneration before that. The element cannot therefore be helpful unless it is read together with other sections of the LRA, more in particular section 186(1)(a). In that case the phrase 'who receives, or is entitled to receive' could be read as meaning based on the current contractual arrangement, he will in future receive or be entitled to receive remuneration (tempering with the contract now could therefore be as good as tempering with the contract then i.e. in the future). It could also mean that once he is in a position to work, or be available for work, he or she would be entitled to remuneration. One should also take note of the reasoning in *Jack v Director - General Department of Environmental Affairs (P734/02 [2002] ZALC 92 (1 November 2002))*, where the court alludes to the fact that advance remuneration (i.e. remuneration before a person starts working) is sometimes allowed. This position does not however assist much in the discussion, as more often than not, the dispute arises when there is not been an advance payment. In fact, where there is advance payment it might also be unlikely, though possible, that the employer might want to terminate that person's contract, therefore risking having to go a long (and difficult) route in recovering the money already paid.

The issue of remuneration also comes up (and *Jack's case* also does touch on this) from another angle, namely that its absence before the person actually starts work might render the contract of employment void (as a contract of employment), as remuneration is one of the *essentialia* of a contract of employment (one should here put aside the debate about whether remuneration does or not constitute one of the *essentialia* of a contract of employment, and assume that it does). The legal fiction of deeming the 'future employee' above should equally apply in the context of whether the person is entitled to remuneration or not.

'Any other person who in any manner assists in carrying on or conducting the business of an employer'

This part of the definition is far more ambiguous than the earlier two. It is even far more problematic given that it is joined to the earlier two with 'and' rather than 'or', implying that it is just an extension of the earlier two, rather than an alternative. (A detailed analysis of this part of the definition is however not deemed necessary within the scope of this paper).

CASE LAW UNDER THE OLD LABOUR POSITION

Whitehead v Woolworths (Pty) Ltd (C 122/98) [1999] ZALC 82 (28 May 1999)

One of the first reported cases around the dismissal of employees before they commence employment is the Labour Court case of *Whitehead v Woolworths (Pty) Ltd (C 122/98) [1999] ZALC 82 (28 May 1999)*. In this case, though different versions were presented by both parties in court the employee, Mrs Whitehead, the applicant in the matter, was allegedly offered a permanent job at Woolworths, the employer (respondent in the matter). The employee accepted the offer, but the employer later repudiated the offer. The employee then, on the basis of the repudiation of the offer, claimed that she had been dismissed, which dismissal was automatically unfair in that, based on the employee's version of events, the employer's decision to dismiss her was motivated by the fact that she was pregnant (in terms of section 187 of the LRA, dismissal as a result of pregnancy or reasons related to pregnancy is one of the grounds for a dismissal to be considered automatically unfair. This makes such a dismissal not easily, if at all, open to justification by the employer).

Alternatively, the employee claimed that the employer had committed unfair labour practice against her in terms of item 2 (a) of Schedule 7 of the LRA. To put things perspective, the unfair labour practice claim relied on here is what is now covered as unfair discrimination under the EEA (which was not yet in operation at the time when the case was initiated and decided). For the purposes of this paper, the discussion is only confined to the first claim, namely that she was dismissed. In dismissal matters, the LRA requires that the employee alleging dismissal must first prove that she has been dismissed. Once the employee has successfully proven that she has been dismissed, the employer must then prove that the dismissal is fair. If the employer fails to prove that the dismissal is fair, then the dismissal is unfair. These stages apply in the case where an employee alleges that she was dismissed for reasons related to incapacity, misconduct or operational requirements. As indicated earlier, where the employee alleges that she was dismissed because of pregnancy or reasons related to pregnancy, or on the basis of other grounds falling under section 187 of the LRA, though the employee must still prove the existence of dismissal, once the employee has also shown that the dismissal was based on one of the grounds under section 187, the dismissal becomes automatically unfair. This therefore, bar exceptional circumstances, denies the employer any opportunity to show the fairness of the dismissal (Du Plessis & Fouche, 2014, p.321).

As Mrs Whitehead claims that she was dismissed on ground of pregnancy, she had to first prove that she was in fact dismissed. Because she claimed to have been dismissed even before she commenced employment, the court had to determine whether termination of contract under those circumstances could constitute dismissal as contemplated in terms of section 186 (a) of the LRA, as it then was at the time of the case (under the Old Labour Position). As indicated above, the section then considered an employer's termination of an employee's 'contract of employment' as one of the meanings of dismissal. The court had to examine whether a mere conclusion of contract of employment (assuming that it was concluded on the facts in this case) implies that the person was an employee even before she started working, and therefore subject to dismissal. The court says in this regard at para 5:

In order to qualify as an employee, it is not sufficient for the Applicant to satisfy the court that a contract of employment was in fact concluded. The coming into being of a contract between the parties may give rise to a contractual claim but does not confer the status of an employee or employer upon the parties as provided for in the Act.

The court at para 7, after analysing the definition of an employee in terms of the LRA, concluded that a person had to 'actually' work for him or her to be considered an employee, amongst other requirements. If a person did not work, he or she must at least have made a tender (see *Whitehead* at para 12). The employee, the court went further, must 'have rendered a service' (other than that of an independent contractor) for him or her to be considered an employee. The court then went further at para 7 and said:

In the circumstances where an offer of employment is made to another and the offer is accepted a contract of employment may come into existence but the parties to that contract do not enjoy the protection of the Act until such time as the offeree actually commences her performance or at least tenders performance in terms of the contract.

The court therefore found the mere breach of a contract of employment, where such a contract in fact exists, does not amount to dismissal (*Whitehead* at para 11).

Jack v Director - General Department of Environmental Affairs (P734/02 [2002] ZALC 92 (1 November 2002)

In this case the employee, Jack, had been offered employment, but before he started, the employer withdrew the offer, stating as the reason for the withdrawal the fact that they had made an administrative error. The withdrawal of the offer came after the employee had accepted the offer, and had already resigned from his previous employment. The parties settled the matter on the issue of dismissal, but the matter had to continue on the issue of costs of the proceedings, as the employer refused to pay the costs of the proceedings. The employer challenged the jurisdiction of the court to deal with the matter, arguing that the BCEA does not apply, as the applicant (Jack) was not an employee. The employer's reasoning was that Jack 'had not rendered services and had not been remunerated as yet.'

The court here emphasizes the strong relationship between a contract of employment and an employment relationship. The court says at para 11:

Historically, the requirements for a contract of employment were derived from the statutory definition of ‘employee’. It is logical to follow that approach as there cannot be a contract of employment unless the parties thereto are employer and employee either at common law or as defined in statutes.

The court here appears to treat a contract of employment and an employment relationship as one and the same thing. The court appears to take the position that every contract of employment must necessarily create an employment relationship as only employers and employees can be party to an employment contract. This observation is further fortified by the court’s comment at para 24, where the court says:

There is nothing in the contract of employment that suggests that the parties did not intend to create an employer-employee relationship. The letter of appointment stipulates the date of appointment as 1st October 2002. Therefore the applicant became an employee and the respondent his employer on 1st October 2002. In my view a valid, binding contract of employment governed by the BCEA was concluded.

The court’s position on the dates on which an employment relationship was created, i.e. on 1st October 2002, appears factually erroneous. There is no debate about the fact that an employment relationship would be in existence on that date (because this date is, in any way, the date on which the employee ought to have commenced employment). The debate is rather about whether an employment relationship was created even before that date (i.e. before the date of commencement of employment). In other words, was the employment relationship created on the date when the employee ‘confirmed his acceptance of the appointment’ i.e. on 19 September 2002, or could it only be created on the date on which he had to commence work, being the 1st of October 2002? Despite this confusion about the dates, the court’s position and reasoning about an employment contract creating an employment relationship appear correct (However a detailed analysis about the relationship between an employment contract and an employment relationship is however not fitting in this paper).

To sum up the case, the court here, unlike in the Whitehead case, takes the position that an employment contract, which can be concluded even before a person starts working, creates an employment relationship. Although the case did not touch on dismissal per se, because the parties had settled on that point, its approach to the question as to when a person commences being an employee does have a bearing as to when such an employee can be dismissed i.e. whether such an employee can be dismissed even before he or she starts working.

Wyeth SA (Pty) Ltd V Manqele and Others (JA 50/03) [2005] ZALAC 1 (23 March 2005)

In *Wyeth SA (Pty) Ltd V Manqele and Others (JA 50/03) [2005] ZALAC 1 (23 March 2005)* (hereinafter referred to as *Manqele case*) an employee’s contract was terminated before he started working, as the employee was, after appointment, found to have made some misrepresentation. The employee took the matter, characterized as a dismissal dispute, to the CCMA, where the CCMA ruled in his favour i.e. ruled that he had in fact dismissed. The Employer took the decision on review to the Labour Court, which still ruled in the employee’s favour. The employer appealed to the Labour Appeal Court, which also ruled in the employee’s favour.

THE AMENDED POSITION

All the above cases were decided under the old LRA position, as it was before the 2014 amendments. As indicated earlier, section 186 (1) (a) does not define dismissal as employer’s termination of ‘contract of employment’ any more, but as employer’s termination of ‘employment’. What are the implications of this change of wording? Is it a meaningless change? Established principles of legal interpretation provide that earlier or old legislation be taken into account when interpreting any new legislation. The interpreters must try and find the mischief that the legislature sought to address by enacting a new provision. Botha (2012: 152) says in this regard:

The historical context of the particular legislation is used to place the provision in question in its proper perspective. This historical context is also known as the mischief rule ...The aim of the rule is to examine the circumstances that lead to the adoption of the legislation in question.

Did the legislature in this new provision intend to change the previous position? If any change of meaning was intended by the new provisions, are the cases discussed above affected? For example, does it mean now that the *Mangele* case could be decided differently, given that dismissal could only have taken place if one has terminated employment, not just a contract of employment (Our answer to this will depend on whether we consider a contract of employment as creating employment relationship or not, i.e. as being synonymous. Our position here is that they are, in the context of that section synonymous. I leave aside the question whether they will also be synonymous in other contexts) . However, my observation as for now is that there was no need for the change, if the change in language was not intended to make proving dismissal difficult in the circumstances discussed in this paper. If the legislature intended to keep the status quo, but creating more clarity, it would have been better to say ‘an employment terminated a contract of employment or employment or employment relationship’, so as to place the issue of whether one can be dismissed before commencing work beyond doubt. In fact, if one were to choose between the two positions, i.e. before and after the amendments, one would consider the previous position, with regard to the matter under discussion here, more understandable.

The need for legislative amendment is also alluded to in *Whitehead* case, despite the court in that case deciding that no dismissal existed. The court says at para 15:

I must add that I find that the definition of an employee in the Act totally unsatisfactory (*sic*). The definition should have included conferring the status of an employee and employer on the parties on the finalization of a contract of employment even if such contract of employment was only to take effect at some future date. I say this because if one of the parties repudiates the contract for reason not valid in law why should the innocent party only have recourse to the ordinary court on the basis of breach of a contract and not be given the protection provided for in the Act. This is particularly important as the amount of compensation the innocent party would receive, depending upon the forum it is obliged to approach, is substantially different.

I support the need to have an amendment to the current definition (in the Amended Position) of an employee and employer, so as to include persons who are party to a contract of employment, but have not yet commenced working. Not conferring such status on an employee does have disadvantages on parties to contracts, if the contracts are terminated before the employees commence employment. If such persons were not to be treated as employees (and such interpretation is possible as all the above cases, including the *Mangele* case, were only decided before the definition in the Amended position was introduced), it does have an impact as to which forums the persons must approach. The CCMA (Commission for Conciliation, Mediation and Arbitration), for example, does not have jurisdiction over a dispute where the parties do not qualify as employees. Nor does it have jurisdiction on disputes around breaches of contract. Going to other forums therefore has an impact on the nature of the remedies to be claimed, and the costs of proceedings.

CONCLUSION

The paper had to look at the legal position around the meaning of dismissal, more especially as it affects persons who have entered into contracts of employment but whose contracts are terminated before such persons commence working. Although the courts were initially divided on the matter, the matter was ‘finally’ settled in the *Manqe* case, which is a Labour Appeal Court decision, where the court decided that a person who has not yet commenced employment could also claim dismissal. This ‘finality’ however now hangs in the balance, given that the *Manqe* case, just like the other decisions it superseded, was decided before the 2014 amendments to the LRA, which amendments changed the definition of dismissal. It therefore now remains unclear if this new definition will be interpreted consistently with the decisions in *Manqe*. Only time will tell, as to which direction the courts are likely to take on this matter. So as to avoid any uncertainty as to which direction the courts might take, the paper recommends that section 186 (1) (a) of the LRA be further amended to specifically cover, in the definition of

dismissal, situations where a person has had his or her contract terminated before commencement of employment. A similar amendment is recommended for the definition of 'employee' and 'employer' in section 213 of the LRA, (and in other legislations where the same or equivalent definition exists) so as to cover persons who have entered into a contract of employment, but whose contracts are terminated before there is commencement of work. This will go a long way in protecting employees, and in substantially giving effect to the right to fair labour practices as provided for in terms of section 23 of the Constitution of the Republic of South Africa, 1996.

REFERENCES

Basic Conditions of Employment Act 75 of 1997

Botha, C. (2012). *Statutory Interpretation. An Introduction for Students*. Fifth edition. Cape Town: Juta.

Constitution of the Republic of South Africa, 1996

Du Plessis, J.V and Fouche M.A. (2014). *A Practical Guide to Labour Law*. Eighth edition. Durban: LexisNexis.

Employment Equity Act 55 of 1998

Jack v Director - General Department of Environmental Affairs (P734/02 [2002] ZALC 92 (1 November 2002)

Labour Relations Act 66 of 1995

Whitehead v Woolworths (Pty) Ltd (C 122/98) [1999] ZALC 82 (28 May 1999)

Wyeth SA (Pty) Ltd V Manqele and Others (JA 50/03) [2005] ZALAC 1 (23 March 2005)

THE PROTECTION OF PERSONAL INFORMATION OF RESEARCH PARTICIPANTS IN RESEARCH CONDUCTED ELECTRONICALLY

Jamwell Maswanganyi, Tshwane University of Technology, South Africa

ABSTRACT

Researchers do from time to time collect data from research participants for use in their research. This collection and processing of information could take place through various means, including electronic means. The collection and processing of information exposes research participants to some harm, more so if it involves more vulnerable research participants. This therefore raises both ethical and legal issues. A number of laws dealing with the protection of research participants in general exist in South Africa. A number of laws specifically dealing with the protection personal information of persons in general, and not specifically dealing with protection of personal information of research participants, more particularly research via electronic means, also exist. The laws specifically dealing with the protection of personal information include the Promotion of Access to Information Act 2 of 2000 (PAIA) and the Protection of Personal Information Act 4 of 2013 (POPI). However, not much clarity exists as to whether these laws sufficiently protect research participants, more particularly in cases where the data is collected and processed by electronic means. The paper therefore examines the sufficiency or otherwise of these laws, in addition to the ethical issues the electronic environment raises.

Keywords: Personal information, technology, research, research participants, ethical principles.

INTRODUCTION

Technology has brought with it new ways of conducting transactions, in various walks of life. The use of technology has also created opportunities for conducting research via electronic means. These new ways of conducting transactions also bring with them challenges, both ethical and legal. Some of the challenges include the way in, and extent to, which personal information of research participants is protected. This paper looks at both the ethical and legal challenges governing the conduct of research, more so if the research is conducted electronically. The paper examines various laws and, in brief, various ethical principles and theories. Though the focus of the paper on the legal aspects is mainly from a South African perspective, the ethical aspects are not confined to any jurisdiction.

AN EXAMINATION THE ETHICAL FRAMEWORK

Apart from raising legal questions, the use of technology also raises ethical questions. It is not within the scope of this paper to give a detailed account of the ethical questions the use of technology raises. The paper therefore only deals with this aspect in brief. I start off by briefly looking at the common ethical problems in research, more especially in the context of the use of technology, then the principles and theories that could guide their resolution. Research that involves human participants, whether conducted electronically or not, often raises problems of invasion of privacy. In other words, the way research is conducted is often intrusive. This problem becomes even more in case where the research is conducted electronically. For example, possibilities of the hacking of computers

are forever present. There are also ethical problems related to lack of informed consent. Participants who are not very familiar with technology might find themselves quickly agreeing to things that they would not have agreed to had they been well-informed.

Another ethical problem could be that as the interaction might also be distant, the research participants might not be in a position to assess whether the persons they are dealing with could be trusted or not. Other problems could be Lack of sophistication, on the part of participants around the use of technology, which could also lead to exploitation of such participants. Lack of information around the use of technology and the absence of technology in some instances, could lead to low participation rates by those affected by such lack of technology or its absence (this could deny such participants opportunities for participation in research that could be useful to their communities).

A variety of principles have been developed by scholars around ethical questions. Beauchamp & Childress have developed four principles, namely non-maleficence, beneficence, justice and respect for autonomy (Van Niekerk, 2010, P.37). Although these principles are not specifically meant for situations where research has been conducted electronically, the principles are generic enough to cover such situations too. In the above examples of problems, the principle of respect for autonomy will be useful in responding to challenges of violation of privacy. The principle will equally respond to questions of lack of informed consent. The principle of justice will be useful in responding to challenges of under-inclusion of certain groups as participants in research, as a result of their lack of technological know-how, or as a result of absence of technological resources at all. This principle will also respond to challenges of exploitation in research. These are but just examples, rather than an exhaustive account, of how some of the existing principles could be applicable to new challenges arising out of the use of technology in research.

Other broad traditional theories like virtue ethics (which focuses on the character of actors), utilitarianism (which focuses on the cost-benefit analysis of actions), deontology (which focuses on principles and duties that actors must subscribe to), Ubuntu (which is a version of communitarianism, more popular in African communities, emphasizing solidarity and mutuality in society), etc., could still provide answers to the problems presented by new technology in research, with some adaption. Other principles, more popular in law than ethics, for example the public interest principle, could also be useful, more especially where the interests of the individual research participants have to be weighed against those of the public.

AN EXAMINATION OF THE LEGAL FRAMEWORK REGULATING ELECTRONIC TRANSACTIONS

Technology has revolutionized the way society conducts itself, including the way transactions are concluded. John Sullins (2010) explains it this way: ‘Everything we do leaves a trail of information, a digital footprint as it were. This information can be looked at in many different ways.’ (p.117). The way research is conducted has no doubt also been affected. The main legislation regulating electronic transactions is the Electronic Communications and Transactions Act 25 of 2002 (ECTA). One should here focus on the key provisions of the ECTA.

The ECTA places electronic transactions legally on the same par with traditional ways of concluding transactions. In other words, if persons conclude a transaction electronically, which would have produced certain legal consequences if it were not concluded electronically, such a transaction’s legal force is not affected merely by the fact that it was concluded electronically (section 22 (1) of ECTA)). This, for example, means that if a contract is concluded electronically, and has complied with all the legal requirements for its validity, the contract will be as valid as if it had been concluded by means other than electronic means. Section 22 (1) of ECTA should be read together with section 11 (1) of the same Act, which places data messages on the same par as messages produced by ways other than electronic means. This remains the position if the information ‘is not contained in the data message purporting to give rise to such legal force and effect, but is merely referred to in such data message’ (Section 11 (2) of ECTA)).

The ECTA also provides that in case a particular document or information is required by law to be in writing, such a requirement is met when the document or information is produced in electronic form, namely being produced by way of data message or being accessible in a form capable of being used for subsequent reference (Section 12 of ECTA). The ECTA further, in relation to electronic transactions, recognizes electronic signatures, and makes advanced electronic signatures mandatory in case the law requires a person's signature, but the law does not specify the format the signature must take (Section 13 (1) of the ECTA)). Where the parties require a document to have electronic signatures but the parties have not prescribed the format of the signature, the signature requirement is met if there is a method of identifying the person and that person's approval of the message and the method was reliable and appropriate 'for the purposes for which the information was communicated' (Section 13 (3) (a) and (b) of ECTA)).

The ECTA further recognizes electronic expressions of intent or other statements as having legal force just like they would have if they were expressions of intent or other statements in non-electronic format, where the parties have not prescribed any electronic signature. In other words, an expression of intent or other statement should not be denied legal force merely because it is produced as a data message or that it does not have an electronic signature, but has evidence of 'other means from which such a person's intent or other statement can be inferred' (Section 13 (5) (a) and (b) of ECTA)).

The ECTA also deals with the problem of document originality. The ECTA in this regard provides that where a particular law requires a document or information to be in original form the requirement is met if a document or information is retained in electronic format, and the integrity of the document, from the time of it being first generated in its final form as an electronic document has passed some assessment in terms of section 14 (2) of the ECTA. The assessment of its integrity must consider that the document has remained substantially complete and unaltered, bar certain additions or changes arising 'from the normal course of communication, storage and display'; further taking into account 'the purpose for which the information was generated'; and further taking into account other relevant factors (Section 14 (2) of the ECTA)).

The ECTA further deals with the question of the time and place for the conclusion of an agreement and communication, dispatch and receipt of data messages. When transactions are concluded, questions often arise as to where and when the transactions shall have been concluded. In transactions having legal force this question is important for the purposes of determining the jurisdiction of the courts or related forums over the transactions. In the case of agreements concluded by electronic means the ECTA addresses this aspect by providing for the time and place of conclusion of an agreement. It provides for an agreement to have been concluded at the time when, and place where, the offeror receives the acceptance of the offer (section 22 (2) of ECTA)). This aspect is important for shedding light on what might happen with regard to jurisdiction if research is conducted but the researchers, the research participants and other stakeholders are not in the same country, or not in the same jurisdiction within the same country.

A question closely related to the time and place for the conclusion of agreements is the question of time and place for the communication, dispatch and receipt of data messages. The ECTA in this regard provides the time when the data message will be regarded as having been sent. The ECTA in this regard provides for a data message to be regarded 'as having being sent by the originator when it enters an information system outside the control of the originator or, if the originator and addressee are in the same information system, when it is capable of being retrieved by the addressee' (section 23 (a) of ECTA)). (One could call this the 'dispatch deeming provision'). The ECTA further provides for the time when a data message will be regarded as having been received. In this regard the ECTA provides for a data message to be regarded 'as having been received by the addressee when the complete data message enters an information system designated or used for that purpose by the addressee and is capable of being retrieved and processed by the addressee' (section 23 (b) of the ECTA)).

With regard to the place of dispatch and receipt of a data message, the ECTA provides for the data message to be regarded 'as having been sent from the originator's place of business or residence and having been received at the addressee's usual place of business or residence' (section 23 (c) of ECTA)). It remains unclear as to what the implication of these provisions in the research context will be. For example, if a person sends informed consent forms electronically from the US, but the person is a permanent resident of South Africa or has a business in South

Africa, must the place of dispatch be regarded as South Africa? This is what section 23 (c) appears to imply. These are some of the questions researchers may have to deal with in the future. Although the ECTA also deals with the protection of personal information, that aspect is dealt with separately below, together with the other legislations focusing the same aspect.

What are the implications of the above provisions in research context? There is no doubt that ECTA does have far reaching implications on the conduct of research. The ECTA clearly puts to rest questions around whether electronic conduct of research would be legally permissible or not: such research is within the law. The ECTA does also clarify questions around signatures, which could be important in the context of the signing of informed consent forms, if that were to be done electronically. The ECTA does also clarify the issue of when and where research could be said to have been conducted. The ECTA does further clarify questions around originality and copies of documents. What remains unclear is the magnitude of the impact, and this only time will tell.

AN EXAMINATION OF THE VARIOUS LAWS REGULATING THE PROTECTION OF PERSONAL INFORMATION

The common law basis

In terms of the common law personal information can be protected under privacy laws, within the field of the law of delict. It could also be protected under the common law right to dignity, which is sometimes treated as a component of the right to privacy (Loubser & Midgley 2010, p.316). It may arguably also be so protected in terms of contract laws, if the parties have undertaken to keep certain information confidential in a specific contract.

Constitutional basis

The Constitution of the Republic of South Africa, 1996 (the Constitution), provides for a number of rights that could be of relevance in the context of the protection of personal information. These include the right to human dignity (section 10); the right to privacy (section 14) and the right to freedom and security of the person, in particular 'the right to bodily and psychological integrity', which also extends to the right 'to make decisions concerning reproduction' (Section 12 (2) (a) of the Constitution). In the United States of America (USA), as was the case in *Roe v Wade*, 410 U.S. 113 (1973), decisions relating to reproduction, for example decisions on abortion, have been considered by the Courts to be privacy decisions.

Other constitutional provisions having a bearing on privacy issues include section 32, which provides for the right of access to information (including personal information) held by the state or another person. The importance of this provision centres around the fact that the request for personal information in the possession of another person can potentially violate the privacy of other persons (This aspect is discussed below under the Promotion of Access to Information Act (PAIA)). Another relevant provision is section 35 (5) of the Constitution, which renders evidence obtained in an unconstitutional manner inadmissible (i.e. if the obtaining of the evidence takes place in a manner that is in violation of the Bill of Rights), if the admission of the evidence is likely to render the trial unfair, or 'be detrimental to the administration of justice'. In the context of research ethics this provision could become applicable in situations where law enforcement officers order researchers to give up personal information of research participants, which the researchers obtained from research participants after securing informed consent from the research participants.

A question could therefore arise as to whether handing over such information to law enforcement officers, in violation of the privacy rights of the research participants, is in breach of the Bill of rights, and therefore rendering the evidence inadmissible in terms of section 35 (5) of the Constitution. The informed consent that the research participants gave to the researchers may not be relied on as justification for handing over such information,

as the research participants would have given informed consent to the conduct of, and participation in, the research itself, and not for the purposes of being used in court (legal) proceedings. The obtaining of information for the purposes of later use in court proceedings, more especially in criminal proceedings, has to meet other more stringent requirements. One is therefore of the view that for researchers to minimize the potential harm (of having to hand over the research participants' information to law enforcement agencies) against research participants, the researchers should inform the research participants (in the informed consent form) about the possibilities of information being later requested by, and handed over to, law enforcement. This will ensure that when the research participants give informed consent, they should also be giving informed consent to the possibility of the information being later requested by, and handed over to, law enforcement agencies.

Legislative framework regulating the protection of information in health research

Various legislations, including the Protection of Personal Information Act 4 of 2013 (POPI), the Electronic Communications and Transactions Act 25 of 2002 (ECTA), the Promotion of Access to Information Act 2 of 2000 (PAIA), the National Health Act 61 of 2003 (NHA) and the Children's Act 38 of 2005 (CA) deal with the protection of personal information, some in detail and some not. Following below is a brief discussion of such legislations, to the extent of their focus on the protection of personal information.

The Protection of Access to Information Act and protection of personal information in research

The Promotion of Access to Information Act 2 of 2000 (PAIA) makes provision for access to information, either in the hands of the state or persons. PAIA gives effect to section 32 of the Constitution of the Republic of South Africa, 1996 (the Constitution), which also makes provision for the right of access to information. What are the implications of these regulatory frameworks in the context of research? The part of the paper discusses, in brief, the provisions of PAIA, and its implications in the context of the conduct of research. The discussion looks at the type (category) of information in respect of which a person may demand access (and the type of information in respect of which a person cannot demand access), the general basis for being entitled to be granted access to the records, the type of information a person must not disclose (i.e. information in respect of which there is mandatory protection), the type of information the state or a person must in fact disclose, the justifiable limitations to the rights of access to information (also see section 9 of PAIA in this instance), etc. The paper then looks at how these provisions will impact on the conduct of research, and health research in particular.

Because the protection of personal information is important in the context of research (in fact PAIA specifically makes it possible for a person to request a record containing a person's personal information, it is important to understand the meaning of personal information. PAIA defines personal information as meaning 'information about an identifiable individual...'. It then stipulates in section 1, without creating an exhaustive list, what would count as personal information. The list includes information about one's race, gender, sex, sexual orientation, social origin, mental health, religion, etc. The definition however excludes information about natural persons who have since passed, if their death is more than 20 years old. This aspect could have cultural implications, or even other implications. For example, the revelation about a dead person's certain medical conditions could indirectly reveal a living person's medical conditions too. From a cultural perspective, the revelations about a dead person's genetic information could also indirectly reveal other living persons' genetic conditions.

PAIA makes provision for mandatory refusal to grant access to records, under certain circumstances. Access must be refused if the disclosure might lead to 'unreasonable disclosure' of a third party or a dead person's personal information (Section 34 (1) of PAIA; Also note s 63 (1) of PAIA which has an almost identical provision). Section 34 (2) of PAIA (and s 63 (2) of PAIA has an almost identical provision)) provides for instances where a request for access to a record may not be refused as contemplated in subsection (1). This will be the case if the

individual about whom the information is requested has consented to the disclosure as per section 48 or in writing (s 34 (2) (a) of PAIA); the information was given to the public body intending to publish the information, if the public body informed the individual beforehand that the information will be made available to the public (s 34 (2) (b) of PAIA); if the information is already publicly available (s 34 (2) (c) of PAIA); where it relates to an individual's health or wellbeing, but who by virtue of being under the age 18 or just being unable to understand the nature of the request is under the care of the requester, if the giving of access to the requested information will be in the best interests of the individual (section 34 (2) (d) of PAIA); if the information relates to a deceased individual and the requester is the deceased's next of kin or the deceased's next of kin has provided written consent and where the information is about the a current or past official of a public body, concerning his or her position or functions (section 34 (2) (f) of PAIA)).

PAIA also provides for mandatory disclosures on public interest grounds. A person must give access to a record if the disclosure of the record would reveal the presence of substantial non-compliance with a law or would reveal evidence of the existence of public safety or environmental risk of an imminent or serious nature and the public interest emanating from the disclosure of the record would outweigh the harm emanating from it (section 46 of PAIA; section 70 of PAIA has an almost identical provision). This provision has serious consequences in the context of health research. Law enforcement agencies may rely on it to force researchers to disclose information obtained while conducting the research, on the basis that the information would reveal the commission of an offence. How substantial must the non-compliance with the law be for it to trigger the section? This creates potential for abuse, and therefore deter research participants from participating in certain types of research. It could make research on substance abuse very difficult, as there is usually a chance that the research participants might reveal some commission of an offence. Research on refugees and other categories of migrants also has that potential.

National Health Act 61 of 2003 and the protection of information

The National Health Act 61 of 2003 (NHA) is the main law providing for health, including health research, issues in South Africa. Although section 13 of the NHA makes the keeping of records obligatory for persons in charge of health establishments, section 14 of the same Act requires information about the users to be kept confidential. Access to, and disclosure of, the information are allowed if such access and disclosure are in the interest of the user (section 15 (1) of NHA)). Access and disclosure are allowed also if the user consents to the disclosure in writing; if access and disclosure are required by a court order or any other law and if non-disclosure poses a threat to public health (section 14 (2) of the NHA)). A health care provider is also allowed to access health records of users for the purposes of treatment, if the user so authorizes and for the purposes of study, teaching or research, if the user, head of the affected health establishment and the relevant health research ethics committee gives authorization (section 16 (1) of NHA)).

In the case of access to health records for the purposes of study, teaching or research, as contemplated in section 16 (1) of the NHA, authorization is not necessary if such study, teaching or research does not identify the users (section 16 (1) (2) of NHA)). The NHA further places a duty on persons in charge of health establishment to 'set up control measures to prevent unauthorized access to those records and to the storage facility in which, or system by which, records are kept' (section 17 (1) of NHA)). This provision is important in the context of the keeping of electronic records, which would be the likely off-shoot of research conducted electronically, as use of technology itself exposes information to multiple, and sometimes unknown risks. Having control measures in place will assist in minimizing the risks. The NHA also makes it an offence for any person charged with the management of a health establishment to do, or not to do, anything that seeks to protect the security of the health records (section 17 (2) of the NHA)). The NHA in this regard does go some way in protecting research participants.

POPI and the protection of personal information

What is the purpose of POPI? Part of the purpose of the Act can be gleaned from its preamble, read with section 2 of the Act, which is to promote the protection of personal information processed by, or under the control of, both private and public bodies. It further gives effect to the right to privacy as provided for in the Constitution. It further seeks to balance the right to privacy and other rights and values, namely the right to access to information, the

values of openness and transparency. Realizing this purpose requires that conditions be set up to control the manner in which information is processed. The Act therefore also creates institutional monitoring mechanism, through the Information Regulator. The Act further provides for remedies in case of breach of privacy.

Section 7 of POPI appears to exclude the application of the Act to literary works, to the extent that it is necessary to reconcile the right to privacy with the right to freedom of expression. This exclusion is a bit vague. Although processing for research purposes is dealt with separately in the Act (and there is no general exclusion from the Act's applicability in case of processing for research purposes, except under a few instances), one imagines that there could be instances where processing for literary purposes and for research purposes overlap.

POPI also regulates and discourages the retention of records longer than is necessary (section 14 of POPI). However, if the retention is for research purposes, the rules are a bit relaxed, so long as there are appropriate safeguards. POPI also provides for notification to data subject when collecting the information (section 18 of POPI). However this is not necessary if the collection is done for research purposes. This could arguably lower protection for research participants. For example, is it not necessary to inform the data subject if the information could be transferred to a foreign country? I think it is necessary. POPI also provides for responsibility to maintain security and confidentiality of the information (section 19 of POPI). There is no exception granted for researchers in this regard.

In conclusion, one could ask: does POPI provide for any lower standard of protection compared to existing legislation? I submit that it does in certain respects, but it is at least more elaborate as to what sort of information is protected.

Children's Act 38 of 2005 and the protection of personal information

The Children's Act 38 of 2005 (the CA) is a generic legislation dealing with the protection of children's rights. The CA aims at giving effect to section 28 of the Constitution, which deals with children's rights. One of the key principles governing the protection of children, covered by both section 9 of the CA and section 28 of the Constitution, is the centrality of the best interests of a child when dealing with the child's interests. There is therefore no doubt that when dealing with the question of protection of personal information of children, the principle of best interest of the child will remain important, in addition to other principles. Although information in adoption registers (relating to children) are usually not accessible to a number of persons, section 248 (1) (f) of the CA does allow such access (or disclosures) if the access is to a person who seeks the information for the purposes of research. Such access however is with the proviso that the identity of the child or his or her parents (adoptive or biological) is kept confidential (section 248 (1) (f) of CA)).

Section 111 of the CA makes provision for a National Child Protection Register, in Part A of which details of abusers or abuses of children are kept. Section 115 generally allows access to PART A of register only to specific officials of the Department, including its Director-General. However section 115 (d) of the CA makes provision for access to the register by persons conducting research, provided that identifying information of the child is not revealed. These provisions do go a long way in protecting children during research.

The ECTA and the protection of personal information

The ECTA also regulates the protection of personal information. The ECTA however only applies to the protection of personal electronically obtained (section 50 of the ECTA). This is sharp contrast to the legislations already discussed above, including POPI, whose application is not restricted to electronic information. The ECTA requires a data controller to have 'express written permission' from a data subject on the collection, collation, processing or disclosure of personal information concerning the data subject (section 51 (1) of ECTA)). A data controller may however collect, collate, process or disclose personal information of the data subject if allowed to do so by law (ibid). The ECTA further prohibits a data controller from electronically collating, collecting, processing or storing personal information of the data subject where the information is not necessary for the lawful purpose for which the data is sought (section 51 (2) of ECTA)). The ECTA further prohibits the use of personal information for a purpose

other than the purpose for which the personal information was requested, unless the data controller has written permission from the data subject, or is permitted by the law to do so (section 51 (4) of ECTA)).

This provision is important to ensure that information collected for research purposes should not later be used for other purposes without the permission of the data subject, or being permitted by law. The ECTA further provides for the destruction or deletion of personal information (of data subjects) that has become obsolete (section 51 (8) of ECTA)). Overall, the ECTA takes the same direction as POPI, except for that POPI has a number of exemption specifically for research purposes, while the ECTA apparently does not have such exemptions. It is however unclear whether section 51 (9) of the ECTA also has research in mind when it allows data controllers to use personal information ‘to compile profiles for statistical purposes and may freely trade with such profiles and statistical data, as long as the profiles or statistical data cannot be linked to any specific data subject by a third party’.

CONCLUSION

This paper had to look at the possible challenges, both legal and ethical, that come with the use of technology when conducting research. The paper had to, in the process, also look at the impact this use of technology has on the protection of personal information of researchers, and how the law regulates this aspect. The paper concludes that the existing legal framework does provide a minimum protection mechanism for research participants. However, their extent of sufficiency will be dependent on how these legal principles are used by Research Ethics Committees and other stakeholders, and how they are interpreted by the courts in case of legal disputes arising. Only time will therefore tell whether the current legislation and other laws are sufficient, insufficient or more than sufficient (over-protective) in so far as the needs of research participants are concerned. With regard to the use of existing ethical principles and theories, the paper concludes that continued adaptability of ethical principles and theories to new situations is possible.

REFERENCES

Children’s Act 38 of 2005.

Constitution of the Republic of South Africa, 1996.

Electronic Communications and Transactions Act 25 of 2002.

Loubser M and Midgley R (eds.). (2010). *The Law of Delict in South Africa. Private Law*. Cape Town: Oxford University Press

The National Health Act 61 of 2003.

Promotion of Access to Information Act 2 of 2000.

Protection of Personal Information Act 4 of 2013.

Sullins, J. (2010). Rights and Computer Ethics. In Floridi L (ed), *The Cambridge Handbook of Information and Computer Ethics* (pp. 116 – 132). New York: Cambridge University Press.

Van Niekerk, A.A. (2010). Ethics Theories and the Principlist Approach in Bioethics In Moodley, K. (ed). *Medical Ethics, Law and Human Rights. A South African Perspective (pp19-40)*. Pretoria: Van Schaik Publishers.

CLEANING SOUTH AFRICA’S COAL SUPPLY CHAIN

Ken Mathu
University of Pretoria, South Africa

ABSTRACT

The strategic importance of coal in South Africa cannot be overemphasized. Coal is the primary source of energy that oils the economic development of the country in form of electricity and liquid-fuels over the last 100 years. Hence, the need to pursue sustainable and clean processes that reduce carbon emissions. Both public and private role players were examined. A qualitative methodology was adopted and the data collected was analyzed for themes via content process, that indicated that the use of alternative sources of energy, and clean coal technologies, reduced carbon emissions, and rendered the South African coal supply chain cleaner and more sustainable.

Keywords: Coal, carbon-emissions, clean-coal-technologies, electricity, renewable-sources-of-energy.

INTRODUCTION

Coal has continued to play a significant role in the socio-economic development of South Africa since its discovery over 100 years ago. The stakeholders of coal supply chain comprise the government and private sector role players. Coal produces 88% of electricity and 40% of liquid fuels in the country (DoE 2015). According to Statistics South Africa, coal’s socio-economic impact was evident, as home electrification reached 85.5% in 2015 (StatsSA, 2015). However, coal usage has its absurdity in carbon emissions that polluted the atmosphere. Hence, it was paramount for the South African coal supply chain to address the carbon emission issues for the benefit of the country and in compliance with the global campaign combating the climate change phenomenon.

The public sector role players in the coal supply chain comprises the South African government, and the state-owned corporations Eskom, and Transnet. The government roles include legislation, issuing of licenses for exploration, mining, water and environmental management among others. The state owned enterprise (SOE) Eskom generates electricity through its fleet of thirteen coal-fired power stations, (Eskom 2009), while Transnet is the (SOE) and the only rail logistics company in the country (Transnet 2008). The South African Energy Regulator (NERSA) is the government body responsible for regulating energy (NERSA, 2009). The private sector is dominated by five leading mining companies namely BHP Billiton, Anglo America, Xstra/Glencore; Sasol and Exxaro producing 80% of coal and their affiliates, the junior miners - black economic empowerment (BEE) companies producing the other 20% (Chamber of Mines SA, 2009). The five mining group of companies own the leading coal terminal, the Richards Bay Coal Terminal (RBCT). The other crucial role player is the Chamber of Mines of South Africa which is the liaison between public and private sectors (Chamber of Mines SA, 2012).

The trend in the coal supply chain is dictated by the coal reserves’ geographical distribution, infrastructure connecting the coal mines and the power stations, and the main coal export terminal at Richards Bay, which is also the largest coal export terminal in the world (RBCT, 2013). The Chamber of Mines of South Africa is the liaison between the government, mining companies and the labor union. For the industry (Chamber of Mines SA, 2015).

THEORY OF GREEN SUPPLY CHAIN MANAGEMENT (GSCM)

The concept of green supply chain management (GSCM) also called sustainable supply chain management (SSCM) is to integrate environmental thinking into supply chain management (SCM). Hence, GSCM is crucial for influencing total environmental impact in any organizations involved in supply chain activities (Chin, Tat & Sulaiman, 2015). A recent research expressed the growing prominence of GSCM/SSCM as the most appropriate means of managing emissions reduction from human activities in industries such as burning coal at power stations for electricity generation (Dubey, Gunasakaran & Papadopolous, 2017).

BACKGROUND TO THE STUDY

The coal characteristics, legislations and other factors from production to consumption that contributed to pollution along the supply chain were explored.

Coal and its Properties

Coal is a fossil fuel and a primary source of energy in South Africa. Coal is formed from accumulation of dead vegetation over many years, undergoing a slow decaying process turning into peat that transforms into coal seams (Anglo Coal, 2007: 47). According to Abbott, Apostolic, Goodman, Hortsman, Jenner, Jewell, Labhart, Maragos, May, Sunderman, Parke, Stein, Wengler and Went, (2009: 53) the slow formation process that takes millions of years make coal a nonrenewable source of energy.

Carbon contents determine the calorific value that determines the classification of coal, ranging from the lowest to the highest calorific value, namely, lignite (25-35%), sub-bituminous (35-45%), bituminous (45-86%), anthracite (86-97%) and graphite same level as anthracite (86-97%) (Abbott *et al.*, 2009: 53).

South African Coal Reserves

The coal reserves in South Africa is approximately 30 408 million tons, the sixth largest reserves in the world. The coal reserves are found in Mpumalanga, Free State, Limpopo, Kwa-Zulu Natal and Limpopo coalfields (DMR, 2009:44).

The South African coalfields are mainly concentrated in the Mpumalanga coalfields that produces over 70% of total national production and the area has most of the coal-fired power stations in the country. The region is also the terminus of the 650 kilometres rail line that transports coal to the Richards Bay Coal Terminal for export. However, the coal reserves in Mpumalanga has entered a depletion stage, and the reserves are expected to become uneconomical to exploit by 2030 (DMR, 2009:46). It is estimated that from around 2020, coal mines in the Mpumalanga area will start relocating to the Waterberg coalfields in Limpopo Province which has abundant and untapped coal reserves (Chamber of Mines SA, 2009:27). There are 73 collieries in South Africa (Prevost, 2009: 27). Most of them are owned by the five leading mining companies that produce over 80 percent of coal in the country. The national distribution of the collieries comprises: Free State (2), Gauteng (1), Kwazulu-Natal (7), Limpopo (2), and Mpumalanga (61) (DME, 2007:44).

Legislative environment

The legislative environment covering the mining industry include the South Africa government's Department of Mineral Resources (DMR), Department of Water and Environmental Affairs (DW & EA) and the National Energy Regulator of South Africa (NERSA). The main legislations include DMR's Mineral and Petroleum Resources Development Act (MPRDA) (Act No. 28 of 2002) that was promulgated in April 2004 (Government Gazette, 2006: 3), and DW & EA's National Environmental Management Act (NEMA) (Act No. 107 of 1998) that controls the

environmental affairs (Government Gazette, 2010: 3). NERSA regulates the energy sectors in electricity, piped gas and petroleum (NERSA, 2009: 5).

Coal Production and Consumption

The present coal mining in Mpumalanga is threatened with depletion, and the future plan is to relocate to the Waterberg coalfields in Limpopo Province from around 2020 (Prevost, 2009:10). Over 80% of coal is mined by five leading multinationals that include Anglo Coal, BHP Billiton, Glencore, Exxaro and Sasol (Chamber of Mines SA, 2009). The giant Medupi power station which is under construction is located in that area (Eskom, 2011:88). The coal consumption is 75% for domestic market and 25% for export (Chamber of Mines, SA, 2009:28)

Eskom is one of the top ten global utilities for generation of electricity, and South Africa's leading consumer of coal as fodder for its fleet of 16 coal-fired power stations that generate 88% of the national capacity (Eskom, 2009:226). Its consumption is approximately 50 percent of the total coal produced, and approximately 66 percent of the total domestic coal consumption (Eskom, 2011:11). The modes of coal transportation to the power stations are 70% conveyor belts, 24% road, and 6% rail (Eskom PE Division, 2008:12). A network of national grid is used to transmit and distribute power directly to the consumers or via local municipalities through a national grid network of 395 419km power lines (Eskom, 2011:169). The plans to increase the grid are at an advanced stage as Eskom has obtained funding from a French company AFD (Eskom Report, 2017).

South African Synthetic Oils (Sasol) is a South African international petrochemical company that manufacture a wide range of petrochemicals and synthetic fuels which accounts for 40% of South Africa's liquid fuel requirements (Sasol, 2012:11). The production model is based on coal-to-liquid (CTL) and gas-to-liquid (GTL) technologies using Fischer-Tropsch synthesis that is heavy in carbon dioxide emissions. Hence, the company's Secunda plant is one of the world's single largest emitter of carbon dioxide.' (Sasol, 2008:83).

The Emergence of Independent Power Producers (IPPs)

The Electricity Act of 2006 allowed the participation of independent power producers (IPPs) in the generation of electricity from renewable sources to transition South Africa into a low-carbon, resilient and just society (DoE 2006). The Act allocated Eskom 70% of electricity generation capacity from coal and other sources, while IPPs were allocated 30% generation capacity from renewable sources. The Act was also supported by DoE's integrated resource planning (IRP) 2010-2030, and the National Development Plan (NDP) 2011-2030 (The Presidency, 2011).

The support of independent power producers (IPPs) through the government's renewable energy independent power producers' procurement program (REIPPPP) launched in 2011 is an initiative that has attracted IPPs investments in renewable sources of energy, presently amounting to USD19 billion (Eberhard & Kaberger, 2016). The government also initiated construction of two giant coal-powered stations of Medupi and Kusile using clean coal technologies namely, super-critical and ultra-super-critical, that control emissions (Eskom, 2016). These developments were also positive contributions towards the global campaign against the climate change phenomenon as advocated by the United Nations Framework Convention on climate Change (UNFCCC). The United Nations body combats the reduction of carbon emissions that mainly emanated from the combustion of the three fossil fuels - coal, oil and gas (UNFCCC, 2009).

PROBLEM STATEMENT

Rendering the South Africa's coal supply chain cleaner and sustainable, while the country continued to have coal as the dominant source of energy for electricity generation, and liquid fuels production.

OBJECTIVE OF THE STUDY

The study looked at the primary, secondary, and empirical objectives to establish how the South African coal supply chain dominated by coal which is heavy in carbon emissions, would be rendered cleaner.

Primary objective

The primary objective looked at the means of cleaning the South Africa's coal supply chain, as coal was positioned as a primary source of energy that cannot be discontinued abruptly.

Secondary objectives

The secondary objectives comprised the literature review on the coal background, legislations and coal supply chain stakeholders, renewable energy and clean coal technologies.

Empirical objectives

The empirical objectives aimed to establish how South Africa's coal supply chain could be rendered clean through:

- Legislation reforms supporting the lowering of carbon emissions,
- increased energy mix reducing reliance on coal use, and
- use of clean coal technologies in new coal-fired-power stations.

METHODOLOGY

The study adopted a qualitative research paradigm to explore the South Africa's coal supply chain using a semi-structured questionnaire, and a sample size of fourteen entities that covered over 80% of the leading role players. The qualitative interview depends very much on how the researcher prepared the participants for the interview Cooper and Schindler, (2008:162-168). 'Qualitative research has substance, gives insight, shows sensitivity and is unique in conceptualization, yet grounded in data' (Corbin & Strauss, 2008: 302). The design in research involves activities of 'collecting and analyzing data, developing and modifying theory, elaborating or refocusing the research questions, identifying and addressing validity threat' and 'activities of collecting and analysing data, developing and modifying theory, elaborating or refocusing the research questions, identifying and identifying validity threats' (Maxwell, 2005:2).

Hence, in this study, design involved the selection participants, inducting them by providing value proposition for the study, undertaking the interview, use of audio-digital data recorder and a field notebook for recording the interviews. The participants were also provided feedback from the interview to ascertain validity and reliability, a process that helped in triangulating the data. Triangulation enhances validity and richness of data by looking at issues from different angles (Lee & Lings, 2008: 239). Also, 'multiple sources lead to a better understanding of the phenomena being studied' (Willis, 2007: 219). According to (Lee & Lings, 2008:235), qualitative data is in form of words or audio that can be transformed into words. A purposive sampling process was used for the selection of the participants who were senior professionals from across the energy industry and the role players. The collected data was transcribed, interpreted, coded, and thematically translated using content analysis to establish the outcome of the study.

RESULTS

The results were determined by the themes that emanated from the study. There were eight major themes and several sub-themes. The major themes comprised: coal mining stagnated, renewable energy efficiency concerns, laws and legislations, public and private role players, transport infrastructure, importance of IPPs, skills shortage across the industry, and environmental impact. The issues of carbon emissions, the importance of IPPs, and the use of clean coal-technologies to exploit the abundant coal resources as inexpensive resource input emerged from all the respondents.

Empirical objective 1: Legislation Reforms Supporting the Lowering of Carbon Emissions (Partially Achieved)

This objective was partially achieved as the main legislation that regulates the mining industry, the Mining and Petroleum Resources Development Act (MPRDA) of 2002 is still not fully accepted in the industry. However, the respondents welcomed the other legislations such as NEMA, the 2006 Act admitting IPPs, the IRP and NDP that have changed the coal mining landscape, as they promote multiple sources of electricity generation that included renewables sources (clean energy) that reduce carbon emissions.

Empirical objective 2: Increased Energy Mix to Reduce Reliance on Coal Use (Achieved)

All the respondents supported the government initiative of REIPPPP that ushered in the IPPs in the electricity sector, that is historically dominated by coal. The respondents were unanimous in their views that all the renewable sources of energy, and nuclear power, reduce carbon emissions. However, they expressed the importance for the use of clean coal technologies to tap on the abundant coal reserves in South Africa, as it provided low cost resources. They asserted that multiple energy mix rendered the South Africa's coal supply chain clean through carbon emissions reduction.

Empirical objective 3: Use of Clean Coal Technologies Rendered Coal Supply Chain Clean (Achieved)

The respondents welcomed the building by Eskom of the two giants coal-fired power stations (Medupi and Kusile) using the new clean coal technologies of super-critical and ultra-super-critical. They expressed interest in being allowed to commence electricity generation using the clean coal technologies, to benefit from the abundant the low cost coal resources in the country.

CONCLUSION AND RECOMMENDATIONS

The study examined the progress in the application of clean coal technologies, and the recent government initiative for IPPs procurement program under REIPPPP that introduced renewable energy to the electricity sector. The UNFCCC campaign on global carbon emissions reduction was also covered. The study achieved the three objectives set, that legislation reforms, reducing reliance on coal by including renewable sources, and the use of clean coal technologies rendered South Africa's coal supply cleaner. The initiatives and the commitment to reduce carbon emissions is an indication of the country moving towards low-carbon economy and cleaning up the coal supply chain.

The study recommended among others introduction of attractive mining policies, pursuance of clean technologies, renewable energy generation be intensified and the implementation of the NDP 2011-2030.

The implementation of these recommendations would significantly clean the South Africa's coal supply chain, and reduce carbon footprint of the products manufactured in the country. This would be a great step towards sustainable clean energy provision, and achieving a low-carbon economy. However, future research would be needed to establish the supply chain collaboration in a multi-resourced electricity supply chain.

REFERENCES

- Abbott, K., Apostolik, R., Goodman, G., Jenner, M., Labhart, G., Maragos, S., May, M., Sunderman, A. D., Parke, J., Stein, J., Wengler, J. & Went, P. 2009. *Foundation of Energy Risk Management: An overview of the energy sector and its physical and financial markets*. Global Association of Risk Professional (GARP). Hoboken, NJ: John Wiley.
- Anglo Coal. 2007. *Annual Report*.
- Chamber of Mines of South Africa. 2009. *Annual Report*.
- Chamber of Mines of South Africa. 2012. *Annual Report*.
- Chamber of Mines of South Africa. 2015. Mining problems: SA in crisis mode. [Online]. Available at: <file:///C:/Users/Mathuk/Downloads/cmsa-20151127-future-sa-mining-industry.pdf>. Accessed: 2016-12-23..
- Chin, Tat & Sulaiman. 2015. Green supply chain management, environmental collaboration and sustainability performance. *Procedia CIRP*, 26; 695-699.
- Cooper, D. R. & Schindler, P. S. 2008. *Business Research Methods*. 10th Edition. New York: McGraw-Hill.
- Corbin, J. & Strauss, A. 2008. *Basics of Qualitative Research*. 3rd Edition. Thousand Oaks (CA): Sage.
- Dubey, R., Gunasakaran, A. & Papadopolous, T. 2017. Green supply chain management: theoretical framework and further research directions. *Benchmarking: An International Journal*, 24(1),184-218. [Online]. Available at: <http://www.emeraldinsight.com/doi/abs/10.1108/BIJ-01-2016-0011?af=R>. Accessed: 2017-04-20.
- Eberhard, A. & Kaberger, T. 2016. Renewable energy auctions in South Africa outshine feed-in tariffs. [Online]. Available at: <https://www.gsb.uct.ac.za/files/REAuctionsInSA.pdf>. Accessed: 2016-12-26.
- Eskom. 2009. *Annual Report*.
- Eskom. 2011. *Annual Report*.
- Eskom. 2016. *Integrated Report*.
- Eskom. 2017. S.A's Eskom signs R6bn deal with France's AFD. *Media Report, March*. [Online]. Available at: <http://www.cnbc africa.com/news/2017/03/17/eskom/>. Accessed: 2017-04-20.
- Eskom Primary Energy Division. 2008. *Special Report*.
- Lee, N. & Lings, I. 2008. *Doing Business Research: A Guide to Theory and Practice*. London: Sage.
- Maxwell, J. A. 2005. *Qualitative Research Design: An alternative Approach*. 2nd Edition. Thousand Oaks (CA): Sage.

- National Energy Regulator of South Africa (NERSA). 2009. *Annual Report*.
- Prevost, X. 2009. Underground gasification. *Inside Mining*, September, pp. 7-9.
- Republic of South Africa (RSA). Department of Environmental Affairs and Tourism 2006. Environmental Management Plan (EMP). *Government Gazette* No. 28753. Vol. 490. Pretoria: Government Printer.
- Republic of South Africa (RSA). Department of Minerals and Energy. 2007/2008. *South Africa's Mineral Industry (SAMI)*. Pretoria: Government Printers.
- Republic of South Africa (RSA). Department of Mineral Resources. 2009. *Molato (Bana le Basadi ba tlile go tlo rera Molato)*. Johannesburg: Primedia.
- Republic of South Africa (RSA). Department of Water and Environmental Affairs. 2010. Carbon emission targets for industry. Pretoria: Government Printer.
- Republic of South Africa (RSA). The Department of Presidency. 2011. National Planning Commission: National Development Plan 2030. Pretoria: Government Printer.
- Republic of South Africa (RSA). Department of Energy. 2013 Integrated Resource Plan (Revised) 2010-2030. Pretoria: Government Press.
- Republic of South Africa (RSA). Department of Energy. 2015. National Strategic Fuels Stock Policy. [Online]. Available at: <http://www.gov.za/about-SA/energy>. Accessed: 2016-12-23.
- Richards Bay Coal Terminal (RBCT). 2013. *Annual Report*.
- Sasol. 2008. *Sustainable Development Result*.
- Sasol 2012. *Annual Report*
- Statistics South Africa. 2015. Energy acknowledges results of Statistics South Africa (STATSSA) on electrification. [Online]. Available at: <http://www.gov.za/speeches/department-energy-acknowledges-results-statssa-electrification-7-jun-2016-0000>. Accessed: 2016-12-23.
- Transnet. 2008. *Annual Report*.
- United Nations Framework Convention on Climate Change (UNFCCC). 2009. Conference of the Parties (COP) on climate change, fifteenth session, 18 December. [Online]. Available at: http://unfccc.int/meetings/copenhagen_dec_2009/items/5262.php. Accessed: 2016-12-08.
- Willis, J. W. 2007. *Foundations of Qualitative Research (Interpretive and Critical Approach)*. London: Sage.

UNDERSTANDING THE INFLUENCE OF BLACK TAX ON UNIVERSITY STUDENTS' ENTREPRENEURIAL INTENTIONS IN SOUTH AFRICA

Raymond Matlala, Vaal University of Technology, South Africa
Richard Shambare, University of Venda, South Africa

ABSTRACT

The rise of high unemployment rate, in particular youth unemployment is a growing concern globally. According to the United Nations World Youth Report more than 73 million young people around the world are affected by unemployment in 2016. To this end, entrepreneurship has been seen as the mechanism to curb this problem. However, "Black tax" a pervasive and yet under reported phenomenon – is crippling South African youths aspirations. This is a result of the financial [and social] pressure of being family breadwinners to the extent that it is crippling their aspirations". Many dreams, plans, and hopes are deferred, and others abandoned, so as to allow for the little available resources to support the extended family, these include starting a business. Subsequently, the purpose of this conceptual paper is to understand and describe how this pervasive and yet under reported phenomenon – "black tax" influence entrepreneurship intentions, particularly among South African university students'. This paper espouses from the scientific evidence that exist between high levels of entrepreneurship intentions and low levels Total Entrepreneurship Activities (TEA) especially in South Africa. Furthermore, the insignificant relationship between students' subjective norm and entrepreneurial intentions in the literature was noted as a gap in the body of knowledge. As a result, this conceptual paper goes on to understand the extent to which black tax influence students' Entrepreneurship Intention particularly, the existence of black tax, as a major phenomenon influencing social norm. Furthermore, this paper proposes a conceptual model which takes in to account black tax as a mediating variable. An extensive review of literature was conducted in order to develop the proposed model. Preliminary findings based on the review of literature suggest that individuals' perceptions of 'black tax' are an antecedent to behaviours such as entrepreneurship. Consequently, this paper significantly contributes to the theoretical foundation in the description of the first attempt to scientifically conceptualize the notion of black tax.

Keywords: Black Tax, Entrepreneurship, Entrepreneurship intention, South Africa and Students.

INTRODUCTION

Schumpeter (1934), one of the earliest authors of entrepreneurship, described the latter as an imperative aspect of economic growth. Specifically, entrepreneurship is the recombination of resources and process to create value. Following this line of thought, entrepreneurship determines not only the supply and demand of goods within an economy, but also determines the type of jobs available within a country as well as the conditions of employment including levels of employment. Consequently, South African youths are "buckling under the financial [and social] pressure of being family breadwinners to the extent that it is crippling their aspirations" (Chabalala, 2016; University of Cape Town Unilever Institute of Strategic Marketing, 2016; Ratlebjane, 2015). Many dreams, plans, and hopes are deferred, and others abandoned, so as to allow for the little available resources to support the extended family (Chabalala, 2016). The effects of black tax are now so severe that they not only shape, but dictate the lives of young South Africans, voluntarily or otherwise. It is for this reason that the notion of entrepreneurship promotion dominates the global socio-economic development agenda (Movahedi, Latifi & Sayyar 2013).

Globally governments' are encouraging entrepreneurship activities to foster economic growth and job creations (Turker & Selçuk 2009). For example, the South African government provide for this policy direction

within the National Development Plan (NDP) where it considers entrepreneurial development as the country's priority for socio-economic development (South Africa 2011). The rise of high unemployment rate, in particular youth unemployment is a growing concern globally (Yaghoubi 2010). According to the United Nations World Youth Report (2016 pp1) more than 73 million young people globally are affected by unemployment. According to Herrington, Kew and Kew (2010 p.12) this trend is also evident in South Africa, in particular young people with limited skills to get into the labour market. As a result of this global challenge, entrepreneurship has been seen as the mechanism to curb challenges of high unemployment globally (Turker & Selçuk 2009; Herrington, Kew & Kew 2010). To this end, several entrepreneurship policies and development structures have been put in place to support entrepreneurship. Despite this though, entrepreneurship levels in South Africa are very low. In fact, South Africa has the lowest Total Entrepreneurial Activity (TEA) levels in sub-Saharan Africa (Herrington *et al.* 2010 p.44).

To try and address this problem, Ebewo (2016) provided new insights into EI, it still did not provide conclusive answers as to which factors influence EI. More interesting, Ebewo (2016 p.161) indicated the existence of two forms of EI – Immediate Entrepreneurship Intention (IEI) and Future Entrepreneurship Intention (FEI). While this is a major breakthrough, Ebewo (2016:148) fails to provide answers for the existence of two forms of EI. Also, even though past studies accounted for the presence of social norms in influencing EI, Ebewo (2016) did not find this relationship. It is against this background, that the purpose of this paper was to understand to what does black tax influence students' entrepreneurship intentions.

LITERATURE REVIEW

The notion of entrepreneurial intention has become a rapidly evolving concept in the field of research (Fayolle & Liñán 2014). The most commonly used theories of entrepreneurial intentions include Theory of Planned Behaviour (TPB) Ajzen (1991); Shapero and Sokol's Entrepreneurial Event (SEE) theory of Shapero and Sokol's (1982). This study applies the TPB. The Theory of Planned Behaviour (TPB) is regarded as the most used theory in predicting entrepreneurial intentions (Ajzen, 1991). The TPB has proved to be a robust model of behavioural intention that accounts well for social factors in decision making (Ajzen, 1991). According to the TPB, intentions are the immediate antecedent of behaviour. These intentions to act are determined by three variables; attitude toward the specific behaviour - only specific attitudes toward the behaviour can be expected to predict that behaviour; subjective norms - beliefs about how people the decision-maker cares about will view the behaviour in question, and; perceived behavioural control – which is seen as people's perceptions of their ability to perform a given behaviour (Ajzen, 2012).

Entrepreneurship intention

The work of Shapiro in the last three decades marks the point at which the literature on entrepreneurial intentions became a rapidly evolving field of research (Fayolle & Liñán 2014). In order to explain the phenomenon of an intent, Vesalainen and Pihkala (1999) defined intent as “a state of mind directing a person's attention toward a specific object or path in order to achieve something”. To further break it down, Bird (1988) also in his study in (1989), defines entrepreneurial intentions as “a conscious state of mind that directs attention (and therefore experience and action) toward a specific object (goal) or pathway to achieve it (means)”. Krueger *et al.* (2000) found no evidence of the significant relationship between perceived social norms on entrepreneurial intentions. In a more recent study, Ebewo (2016) also did not find this relationship. As a result, the purpose this study seeks to address and tries to explain the gap by the existence of black tax, as a major phenomenon influencing social norms, and the next section briefly unpacks social norm as a determinant of entrepreneurship intention.

Authors such as Kautonen, Van Gelderen & Tornikoski (2013 p.2) consider entrepreneurship as a process that occurs over time. This process can be categorised into three phases: a) the pre-launch, (b) launch, and (c) post-launch phases (Baron 2007). Each of these phases corresponds to precise tasks and actions such as entrepreneurial intent and opportunity search, discovery and recognition, evaluation, and exploitation (Shook, Priem & McGee, 2003). Consequently, this study focuses on the pre-launch phase. Figure 1.1 illustrates how this process fits into this study, which translates into the intention, or as some refers to it, as intent.

Figure 1.1: The traditional Model of Entrepreneurship Intention

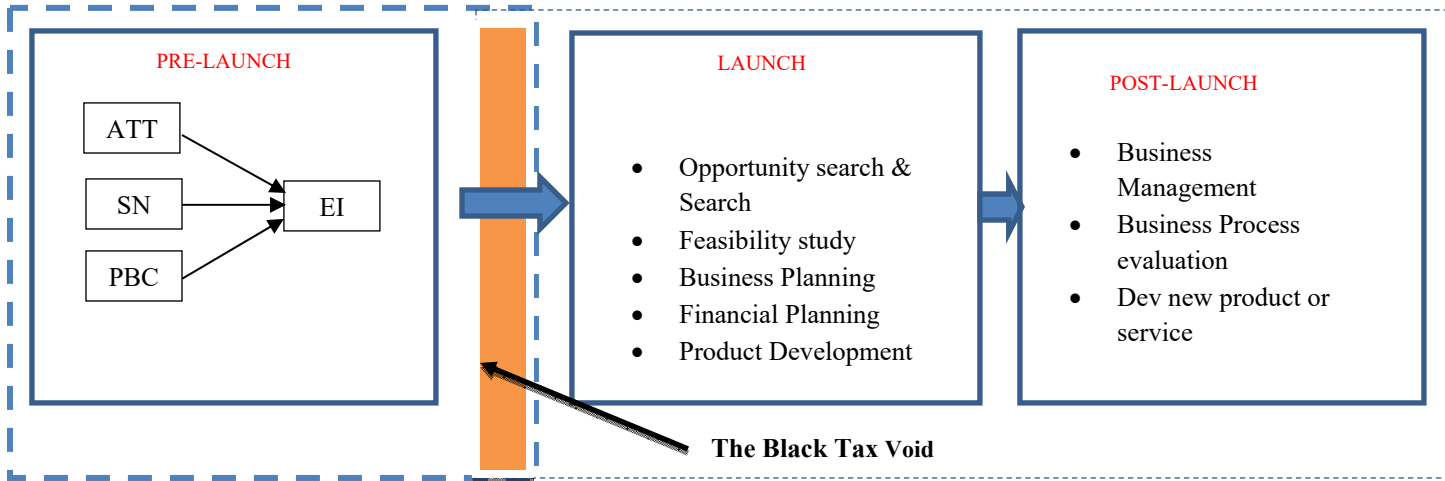

This is a traditional model used by previous studies to measure entrepreneurship intention across board. This model is based on Ajzen Theory of Planned Behaviour (TPB). It is however evidently proven as suggested by Moriano et al. (2012) that the determinants that predict entrepreneurial intention varies across countries and cultures. Which evidently indicate that Ajzen model of entrepreneurship intention does not adequately address South Africa’s context. Much as the traditional model is widely used and accepted, it does not adequately address the some of the social factors based on South African context, in particular black tax, as an influence in the actual implementation and starting of businesses by graduates, as past studies have tested the intention of students’ positive. Following Ajzen model of entrepreneurship intention was the “contemporary model proposed by Ebewo (2016). In a more recent study Ebewo (2016), focussed on understanding how universities and entrepreneurial environment influence entrepreneurial intentions (EI). The latter study provided new insights into EI, the study made a significant discovery which identified a gap on Ajzen model. Ebewo (2016) indicated that two forms of EI exist – immediate EI and future EI as compare to Ajzen model which by default have the two combined (See Figure 1.2).

Figure 1.2: The Contemporary model of Entrepreneurship Intentions

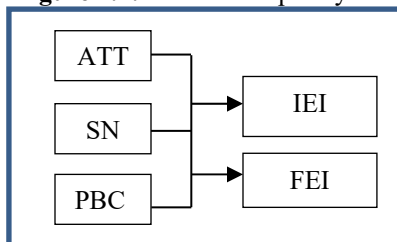

Source: Ebewo (2016)

While this is a major breakthrough and contributes to the body of knowledge in the field of IE, the question still remains as Ebewo (2016) fails to provide answers for the existence of these two forms of EI. Also, even though past studies accounted for the presence of social norms in influencing EI, Ebewo (2016) did not find this relationship. Also, Krueger *et al.* (2000) who investigated the intention-based models of entrepreneurship and tested for the effect of perceived social norms on entrepreneurial intentions also did not find a positive relationship between social norm and EI. It is for this reason that this study postulates that this gap might be that of subjective norm which is constituted by black tax as a component of social norm in the African context, which has never been measured due to the stigma that it does not exist and lack of scale thereof.

Some local scholars have attempted to study entrepreneurial intention in Malaysia, several limitations can be found in their studies. For instance, Ismail et al. (2009) focused on the influence of personality traits on entrepreneurial intention. In addition, Zain et al. (2010) focused on personality and economic traits; meanwhile, Nga

and Shamuganathan (2010) emphasized the influence of personality and demographic factors. Apparently, no other variables were tested in their studies; thus causing limited understanding of the influence of other factors towards entrepreneurial intention. Without doubt, from the literature collection, there are numerous studies using theory of planned (TPB) to predict entrepreneurial intention.

Nonetheless, some limitations can be identified from the past literature. In some recent studies, Do Paço (2011), Moriano et al. (2011) did not integrate other variables into their TPB model to predict intention. Sommer and Haug (2011) have extended the model, some important variables were excluded in their studies, such as personality traits and social ties. These limitations have caused the determinants that affect entrepreneurial intention still remain unclear. Most importantly, TPB has not been well tested in local setting to study entrepreneurial intention particularly in the African context factoring black tax as a major phenomenon influencing entrepreneurship intentions (Wei-Loon Koea, Juan Rizal Sa'arib, Izaidin Abdul Majidc, Kamariah Ismaild 2012:197). It is for this reason that this paper proposes a revised model of entrepreneurship intentions particularly in the South African contextual settings and provides answers to the gap in the body of knowledge with respect to TPB and its relevance to South African local settings.

PROPOSED CONCEPTUAL MODEL

To measure the influence of black tax in entrepreneurship intentions, the proposed conceptual model, developed mainly from the extant literature, becomes useful (see Figure 1.3). To understand how individuals become entrepreneurs, the Entrepreneurship Intentions (EI) model is used (TPB). The EI model is applied in this paper to test the influence of black tax on university students' EI for both Immediate and Future intention.

Figure 1.3: Proposed Entrepreneurship intentions model (The Black Tax Void (BTV)).

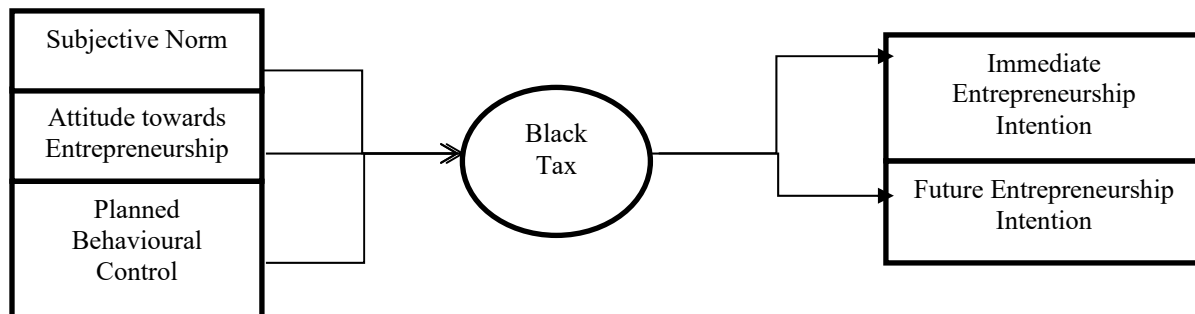

Source: Adapted from Linan (2004); Liñán and Chen (2009) and Ebewo (2016).

Social norm as a determinant of entrepreneurship intention

According to Linan (2004), social norms play an important role in constructing social order (p.17). Furthermore, the author also states that such norms are the behavioural expectations and cues within a society or group. This study concerns itself with the influence of social norm as a determinant of entrepreneurship. To this end, the effect of perceived social norms on entrepreneurship intention will be robustly investigated in this study. As explained by Elster (1989), for a norm to be defined as a social norm, it has to meet the following two criteria: they should be (a) shared by other people and (b) sustained by the approval of other people. Elster (1989) continues to say that social norms are not individual self-interest, but rather generally what a group or community sets and enforces as their communal norms (Elster, 1989). Consequently, social norm is defined as the unwritten rules of conduct of a particular group of individuals (Elster, 1989). The referents refer to a group of people who are close to an individual. These include but are not limited to family, peers, spouses, close friends and teachers. As with the notion of black tax, which is a classification of the subjective norm of an individual, the following section briefly explains black tax, its forms, and how it is linked with student entrepreneurship intention.

Black tax: A South African Perspective

The term “black tax” currently have no scientific definition. This phenomenon is fairly new and has yet to receive much attention from researchers and scholars. The only attention that is captured about black tax in South Africa is through newspaper articles which are largely opinions and views rather than scientific. Although, all of this has stimulated debates and triggered new line of thinking, there still exist multiplicity of definitions of what constitute black tax. According to Seid (2016) the term “black tax” is used to describe the obligation of employed black South Africans to provide for their extended family (p.1). Similarly, however in a different context Matubatuba (2016) view black tax as black working class individuals who faced with the responsibility of supporting family members. while Mhlungu (2015 p.1) posit that “real financial and social implications for being a member of one or more a group or society – people who are deliberately and systemically denied opportunities, equal rights and freedoms; who are paid less; who travel further to work; who have little or no social security nets; who come from backgrounds where there are fewer family members employed or educated”.

Notwithstanding the above, this paper defines black tax a societal expectations which translate to social norm. Our definition goes on in indicating that this societal expectation comes in different forms and not only in monetary value. The paper further posit that one’s responsibility to provide for family and relatives has been observed to be an important antecedent in defining people’s behaviour in collectivist countries such as South Africa. In other words, individual persons will act in a manner that ensures that they live out society’s and family’s expectations. Accordingly, Gerald Mwandambira, refers to this as “sandwich generation” rather than “black tax” as the former is more inclusive of other races. This problem is most common in previously disadvantaged groups, but is equally applicable to other racial groups (Ratlebjane, 2015). Consequently, this paper views this concept as “social tax” and not black tax, the proposed term eliminate the notion that this only affects black people and that it is only based on monetary value. In the South African context this might well be seen as the concept of Ubuntu that espouse “good or ideal morals” and behaviour (Gelfand, 1970).

The philosophy of Ubuntu derives from a Nguni word, ubuntu meaning “the quality of being human.” Ubuntu manifests itself through various human acts, clearly visible in social, political, and economic situations, as well as among family (Flippin, Jr, 2017). According to Shambare (2016) Ubuntu refers to an African philosophy that seeks to promote harmonious relations and interaction among people (p.216). This philosophy suggests that a person can only truly and fully exist if he or she co-exists with others in his or her community. In other words, this means that one should always have a strong sense of consideration for others. According to the philosophy of Ubuntu, a person fully becomes mature and ‘complete’ by making his or her needs subservient to those of others (Gelfand, 1970).

According to Matubatuba (2016 p.1), the following are some of the examples and types of black tax;

- Support in a form of contribution to family living expenditure such as groceries, water and light,
- (a) Support in a form of tuition fees of a sibling or other close individual,
 - (b) Support in a form of emergency expenses such as medical bills and funerals.
 - (c) Support in a form of extending a small family house into a bigger house.
 - (d) Acting on fulfilling other non-financial family responsibilities in lieu of ones aspirations.

According to the UCT Unilever Institute aspirations report (2016 p.44) black tax hinders youth from achieving their aspirations. Furthermore, the report provide some of the factors that constitute black tax which include lack of jobs, lack of assets which prevents access to credit and lack of access to quality education. The report revealed that South Africans' aspirations include financial stability; belonging; freedom; comfort; health; experiences; the need to "give back"; and respect. Amongst other things, the reports indicate that individuals would be respected by society if they are able to support their families. Furthermore the report reveals that over 30 per cent of the responded indicated that family responsibilities are holding them back from progressing.

CONCLUSION AND RECOMMENDATIONS

The term “black tax” currently have no scientific definition. This phenomenon is fairly new and has yet to receive much attention from researchers and scholars. The only attention that is captured about black tax in South Africa is through newspaper articles which are largely opinions and views rather than scientific. Although, all of this has stimulated debates and triggered new line of thinking, there still exist multiplicity of definitions of what constitute black tax. This conceptual paper has attempted to conceptualize the notion of black tax not only as a monetary value but also as a none-monetary. Also, the paper argues that black tax should not be linked to any race, as it affects all races in South Africa. Furthermore, the paper argues that black tax can play two roles, a pull (which can be a holds back individual e.g. supporting family member financially) and a push factor (which provide opportunities for individuals e.g. taking over a family business). The paper provided a theoretical understanding of black tax, particularly in collective nations such as South Africa. Using literature particularly Ebewo (2016) the paper found that black tax has an influence to students’ entrepreneurship intentions particularly, the existence of black tax, as a major phenomenon influencing social norm. However, since this is a conceptual paper, the extent to which black tax has on entrepreneurship intentions remains scientifically unknown. It was imperative to first conceptualize and ascertain the existence of this phenomenon and understand the operational definition of black tax, its relationship to social norm and types of black tax that exists in order to carry out a scientific study to fist develop the scale to measure black tax, then carryout a scientific study to measure the influence. The paper argues that black tax has an influence in entrepreneurship intentions, particularly on social norm as suggested by Ebewo (2016). The latter study provided new insights into EI among youths. Of note, it was able to decompose EI into two constituent elements namely, Immediate Entrepreneurship Intention (IEI) and Future Entrepreneurship Intention (FEI) (Ebewo, 2016). The significance of this finding was that the decomposed EI model is able to account for the presence of social norms in the EI model, which other studies could not. In Ebewo’s (2016) decomposed model, the effect of subjective norm is significant if, and only if EI is decomposed into IEI and FEI. The latter model, as proposed by Ebewo (2016), partially explains the low present-day TEA levels in South Africa. This is so because youths sometimes choose to defer their decisions to engage in entrepreneurial activities to the future, due to FEI. This explanation of such behaviour can very well be extended towards explaining individuals’ desire towards entrepreneurship. To further provide answers to the latter, this paper proposes a conceptual model which takes in to account black tax as a mediating variable. An extensive review of literature was conducted in order to develop the proposed model. Preliminary findings based on the review of literature suggest that individuals’ perceptions of ‘black tax’ are an antecedent to behaviours such as entrepreneurship. Consequently, this paper significantly contributes to the theoretical foundation in the description of the first attempt to scientifically conceptualize the notion of black tax. Furthermore the effect of black tax as a major phenomenon influencing a social order of an individual or group. The paper argues that the explanation of such behaviour can very well be extended towards explaining individuals’ desire towards an intention in the context of this paper would be entrepreneurship intentions. The paper concludes by suggesting that black tax might very well be the societal piety that influences youth to seek employment in lieu of engaging in entrepreneurship after schooling system, in order to advance the aspiration of the society, either being immediate or extended family and friends. Following the limitations of this study, the paper proposes qualitative, quantitative and mixed method studies in this area. Also, it was noted from literature that most studies used regression analysis to measure the relationship between subjective norm and entrepreneurship intensions which to some extend does not account for social norm adequately, particularly in collective nations such as South Africa. The paper proposed future studies to use structural equation modelling to testing the relationship between subjective norm and entrepreneurship intentions, as this have shown different results compare to regression analysis in the more recent studies.

REFERENCES

- Ajzen, I. (1991). The theory of planned behavior. *Organizational behavior and human decision processes*, 50(2), 179-211.
- Ajzen, I. (2012). *The theory of planned behavior*. In: Lange, P.A.M. Kruglanski, A.W. & Higgins, E.T. (Eds.). *Handbook of Theories of Social Psychology*, London, UK: Sage, 1, 438-459.
- Baron, R.A. (2007). *Entrepreneurship: A process perspective*. In J. R. Baum, M. Frese & R. A. Baron (Eds.), *The Psychology of Entrepreneurship*. (pp. 19-39). Mahwah, NJ US: Lawrence Erlbaum Associates Publishers.
- Bird, B. (1988). Implementing entrepreneurial ideas: The case for intention. *Academy of Management Review*, 13(3), 442-453.
- Chabalala, J. (2016). Black people find themselves having to pay 'black tax' – survey. [Online] <http://www.fin24.com/Economy/black-people-find-themselves-having-to-pay-black-tax-survey-20161108>. [Accessed: 02/03/2017].
- Do Paco, A., Ferreira, J., Raposo, M., Rodrigues, R.G. & Dinis, A. (2011). *Universities' Entrepreneurship Education and Regional Development: a Stakeholder Approach*. University of Beira Interior, Portugal.
- Ebewo, P. (2016). Entrepreneurial environment and the development of arts students' entrepreneurial intentions: a South African framework. Dissertation. TSHWANE UNIVERSITY OF TECHNOLOGY.
- Elster, J. (1989). *The cement of society: A survey of social order*. Cambridge University Press.
- Fayolle, A. & Liñán, F. (2014). The future of research on entrepreneurial intentions. *Journal of Business Research*, 67(5), 663-666.
- Flippin jr, W. (2017). Ubuntu abantu abeLungu. [Online]. Available: http://www.huffingtonpost.com/reverend-william-e-flippin-jr/ubuntu-applying-african-p_b_1243904.html. [Accessed: 26/02/2017].
- Gelfand, M. (1970). Unhu – The personality of the Shona. *Studies in Comparative Religion*, 4(1).
- Herrington, M., Kew, J. & Kew, P. (2010). *Tracking entrepreneurship in South Africa: a GEM perspective*. Citeseer.
- Kautonen, T., Van Gelderen, M. & Tornikoski, E.T. (2013). Predicting entrepreneurial behaviour: a test of the theory of planned behaviour. *Applied Economics*, 45(6), 697-707.
- Krueger, N.F., Reilly, M.D. & Carsrud, A.L. (2000). Competing models of entrepreneurial intentions. *Journal of Business Venturing*, 15(5), 411-432.
- Liñán, F. (2004). Intention-based models of entrepreneurship education. *Piccola Impresa/Small Business*, 3(1), 11-35.
- Liñán, F. & Chen, Y. (2009). Development and Cross-Cultural Application of a specific instrument to measure entrepreneurial intentions. *Entrepreneurship Theory and Practice*, 33(3), 593-617.
- Matubatuba, T. (2016). Black tax, ubuntu and the opportunity for brands [Online]. Available from: <http://themediainline.co.za/2016/05/black-tax-ubuntu-and-the-opportunity-for-brands/>. [Accessed: 19/08/2016].
- Mhlungu, G. (2015). Black Tax is not real. [Online]. Available <http://city-press.news24.com/Voices/Black-tax-is-not-real-20150508>. [Accessed: 15/07/2016].

- Moriano, J. A., Gorgievski, M., Laguna, M., Stephan, U., & Zarafshani, K. (2012). A cross-cultural approach to understanding entrepreneurial intention. *Journal of career development, 39*(2), 162-185.
- Movahedi, R., Latifi, S. & Sayyar, L.Z. (2013). The Factors Affecting Agricultural Students' Attitude towards Self-Employment and Entrepreneurship. *International Journal of Agriculture and Crop Sciences, 5*(16), 1813-1819.
- Ratlebjane, M. (2015). How 'black tax' cripples our youth's aspirations. [Online]. Available <https://mg.co.za/article/2015-10-29-how-black-tax-cripples-our-youths-aspirations>. [Accessed: 23/07/2016].
- Seid, S. (2016). Black tax blocks road to success-for many employed South Africans. [Online]. Available <http://www.timeslive.co.za/thetimes/2016/09/29/Black-tax-blocks-road-to-success-for-many-employed-South-Africans>. [Accessed: 23/03/2017].
- Schumpeter, J.A. (1934). *The theory of economic development. An inquiry into profits, capital, credit, interest, and the business cycle*. New Brunswick. London: Transaction.
- Shapero, A. & Sokol, L. (1982). *Social Dimensions of Entrepreneurship*. In: KENT, C., SEXTON, D. & VESPERS, K. (Eds.). *The Encyclopaedia of Entrepreneurship*. Englewood Cliffs: Prentice-Hall.
- Shambare, R. (2016). Consumer Adoption of E-Government in South Africa: Barriers, Solutions, and Implications: In: in Gbadamosi, A. *Handbook of Research on Consumerism and Buying Behavior in Developing Nations*, , Hershey PA, USA, 190-217.
- Shook, C.L., Priem, R.L. & Mcgee, J.E. (2003). Venture creation and the enterprising individual: A review and synthesis. *Journal of Management, 29*(3), 379-399.
- Sommer, L., & Haug, M. (2011). Intention as a cognitive antecedent to international entrepreneurship—understanding the moderating roles of knowledge and experience. *International Entrepreneurship and Management Journal, 7*(1), 111-142.
- South Africa. (2011). National Development Plan Vision for 2030 [Online]. Available from: <http://www.npconline.co.za/medialib/downloads/home/NPC%20National%20Development%20Plan%20Vision%202030%20lo-res.pdf> . [Accessed: 01/06 2014].
- Turker, D. & Selçuk, S. (2009). Which factors affect entrepreneurial intention of university students? *Journal of European Industrial Training, 33*(2), 142-159.
- United Nations. (2016). The World Youth Report on Youth Civic Engagement [Online]. Available from: http://www.youtheconomicopportunities.org/sites/default/files/uploads/resource/un_world_youth_report_youth_civic_engagement.pdf . [Accessed: 20/07/2016].
- University Of Cape Town Unilever Institute Of Strategic Marketing. (2016). *Aspiration report 2016*. Cape Town: University of Cape Town Unilever Institute of Strategic Marketing.
- Vesalainen, J. & Pihkala, T. (1999). Entrepreneurial identity, intentions and the effect of the push-factor. *Academy of Entrepreneurship Journal, 5*(2), 1-24.
- Wei-Loon Koea, Juan Rizal Sa'arib, Izaidin Abdul Majidc, Kamariah Ismaild (2012) “Determinants of Entrepreneurial Intention Among Millennial Generation” *Procedia - Social and Behavioural Sciences, 40*: 197-20.
- Yaghoubi, N.-M. (2010). Factors affecting the adoption of online banking-an integration of Technology Acceptance Model and Theory of Planned Behavior. *International Journal of Business and Management, 5*(9), 159-165.
- Zain, Z. M., Akram, A. M., & Ghani, E. K. (2010). Entrepreneurship Intention Among Malaysian Business Students/l'esprit d'entreprise chez les etudiants en commerce malaisiens. *Canadian social science, 6*(3), 34.

CURRICULUM REFORM AS A VEHICLE FOR CHANGE IN THE FIELD OF PUBLIC ADMINISTRATION

NS Matsiliza
Durban University of Technology

ABSTRACT

This study notes the determinants of planning and designing curriculum of the undergraduate studies in public management, using the case of universities of technologies. The need for public administration and management (PAM) curriculum reform in higher education received much attention as part of the national agenda for transformation in the post-apartheid South Africa. This article contends that curriculum reform in the field of public management has been adopted as a vehicle for change to respond to the national agenda for transformation in the post-apartheid era. However, Policy reforms that influence teaching and learning in Higher Education (HE) emanate from global challenges, regional and local needs. Findings from this paper contributes towards the discourse of curriculum reform in higher education.

Keywords: Curriculum, Syllabi, learner-centred approach, policy reforms, transformation.

INTRODUCTION

Using the case of the University of Technology (UoT), this paper argues that curriculum reforms are part of the agenda for transformation in higher education hence they must be responsive to stakeholders' needs. Saadun and Lewis (2016:265) argue that universities worldwide are still struggling to design and prepare their curriculum since the academic preparation must derive value from current realities, which emanate from the organisations and the external environment. Some of the intrinsic institutional factors include resource management, institutional culture, teaching and learning initiatives, capping of numbers, academic qualifications and skills and student needs. In this current dispensation, government has attended to policy reforms that implied the curriculum democratization to eliminate inequalities of the past.

While Institutions of Higher Learning (IHL) are compelled to translate their academic programmes to suit the national and regional goals of transformation, curriculum reforms are set to respond to national and regional needs of training and producing competent professionals that can be absorbed in the public sector. The implication of such efforts is reflected on the transmission of knowledge in such institutions. Stakeholders and government expect the UoTs to contribute to the national economy by producing competent and skilled graduates that will meet required standards and outcomes that are relevant to the industry and the society. The main goal of curriculum reform is to respond to the national transformation agenda to enhance quality teaching and learning that will develop and produce competent graduates with attributes needed in the world of work. The major focus of teaching and learning in a UoT is to produce skilled and professional work force that will be absorbed in the economy to contribute in development of the national economy that will later on improve the quality of life of all citizens. This study's aim is to critically analyse the contextual challenges of curriculum reforms focusing on teaching and learning in public management and administration, contextualising trends in curriculum reforms in PAM, first write the term in full and bracket the abbreviation conclusions and recommendations.

The main problem articulated by this paper lies on the fact that curriculum reform in PAM does not represent all the values and aspirations of the society due to the legacy of the apartheid and colonial regime that has been entrenched in the disciplinary paradigms. This paper intends to respond to the question of: What are the

determinants of curriculum reform scenario in the field of public administration and management in a university of technology? This paper uses a qualitative document analysis, and draws data from various sources such as literature review, books, policy documents, articles from accredited journals.

DISCOURSES IN CURRICULUM REFORMS

Education can be regarded as a vehicle for change aiming at attaining socio-economic goals in a society. However, education can transmit knowledge embedded on norms, values and aspirations of a society through various generations. It is in this context that a curriculum is imperative to shape those values of the society. However, university curriculum must be constantly changed to be responsive to the needs of the stakeholders. Sometimes, policy-makers while having good intentions in steering curriculum reforms, put much of their energies focusing too much on the 'what' (enacting curricular policy/legislation) of anticipated educational change while neglecting the 'how' (implementation and practice) of it (Bakah, Voogt and Pieters, 2011:68). A curriculum that does not focus on the norms and values of the present generation is defeating the very goal of responsiveness towards national and regional needs. Curriculum reforms in higher education (HE) have become the focus of national policy development in the post-apartheid South Africa. However, curriculum issues and questions are centred at macro and micro institutional levels, engaging different stakeholders globally and nationally.

Killen (2010: 51) identifies three approaches of designing a curriculum; a content based approach, an experience based approach and outcomes based approach. In a content-based approach the content in which students must learn is identified, while in an experienced based the student learning experiences are identified. Outcomes-based approach starts with identifying what the learners need to know and can do at the end of the lesson. However, this article argues that a curriculum must be able to take into consideration a constructive approach, to allow learners to acquire knowledge by interacting with their environment instead of relying only on what the instructors tell them. Curriculum is expected to involve participants from diverse forums, to acknowledge their psychological tools such as language, beliefs, values and approaches to problem solving that will bring about a new social order. Proponents of transformation view curriculum as a 'social construction' (Maila, 2009: 29). However, Westbury (2003) views 'curriculum' as symbolising a loosely coupled system of ideologies, symbols, discourses, organizational forms, mandates and classroom practices. These ingredients mirror the diversity and complexity of the societal needs that permeate changes at different times.

Institutions of higher learning are responding to the complex environmental needs and demands that compels them to adapt to change together with other stakeholders (Brintnall and Mealy, 2014: 160). However, through curriculum development academics hold power to regulate knowledge production and resource allocation for educators and learners. In that perspective, the states play a supervisory role through various interventions on decision-making and policy reforms in teaching and learning. In the traditional way of teaching, universities views curriculum as a private matter, whereas in a learner centred paradigm curriculum focuses on the student needs and those of other stakeholders. Freire (1993) respects the views of the teachers and the institutions, by arguing that curriculum should be designed with some considerations on references and frames of the traditions of the past. The South African government plays a supervisory role in the education system. Hence, it allows institutional autonomy and academic freedom to exist, while regulating the system in its operations. In addition, government allows institutions of higher learning to exercise their institutional autonomy to decide on the curriculum model they would follow while they design curriculum without deviating from the university values and prescripts, and that of discipline. Qualification bodies and associations also plays a role in advising institutions on how to design and implement their curricula.

In consideration of the constructivism, the curriculum designs and reforms must consider the needs and the aspirations of the learners, especially identifying how the learners will respond in interpretation of knowledge. In the constructivist paradigm, curriculum designers acknowledge how learners play active roles in acquiring knowledge using their inherent experiences that could be socio-cultural. A growing emphasis on socio-economic policy literature considers the role of state and society on economic governance by owners of production can be used to turn-around and re-invent the new curriculum where government can redress those imbalances that has been

experienced by learners through case study method of teaching. However, the CHE (2004) recognised a hybrid and flexible curriculum for undergraduate studies could provide synergy and articulation of learners from one level exit outcome to the next one.

Reflecting on the curriculum discourses, Karseth (2005: 3) notes some merits on the disciplinary curriculum reform, where there are emerging vertical pedagogic relations between teachers and students, with states that the rules of selection of curriculum content and of evaluation are residing in the hands of the teachers. On the other hand, faculty members who emphasises that education should be an apprenticeship into specific knowledge domains to develop specific skills relevant for specific profession initiate the vocational discourse shaping the vocational curriculum model. However, Universities of Technology have inherited work integrated learning (WIL) from the former out-structured Technikons. The focus of WIL is to merge the theory taught in the classroom with the practical work done in the public sector and the industry. Public Administration has always been regarded as an 'Art' and a 'Science'. Public Administrators are creative and analytical / scientific, meaning that they are involved in research that promote improvement in decision-making skills that enables practitioners in public service to implement government policies to benefit the broader society (Brintnall and Mealy, 2014: 162). It is imperative to note some of the National Objectives that lead to transformation in South Africa.

However, it has always on the agenda of this discipline to reincorporate service learning and internship into the curriculum to merge the theory based learning with the practice so that it can address the needs of the society. Although the merging of practical and theory differs in different programmes and levels of study, schools and departments in Public Administration have promoted the ability to meld concepts and theories with practice as an integrated approach in their Teaching and Learning. Kuye (2014:11) in assessing the scholarship and challenges of the future affirms that scholarships should be assessed using curriculum as a criterion for improvement in research. Research updates the pedagogy of the field of Public Administration in order to link the theory with the practice, by engaging in constant debates with the practitioners in public service. It is also important for the discipline of Public Administration not to misplace sight of the environment of its operation in different government levels because it has always been preserving innovative approaches to the field.

THE FIRST PHASE OF CURRICULUM REFORMS

Universities of Technology have re-curriculated twice in the post-apartheid South Africa. In 1999 an advisory committee was appointed at the former Technikon of South Africa to advise on the capabilities of the institutions regarding the reform of the curriculum for the National Diploma in Public Management as part of the agenda for the restructuring of Higher Education in South Africa. In the UoT sector, which was formally composed of Technikons, PAM curriculum reforms were organised and facilitated by the former Technikon South Africa (TSA), which was later re-incorporated to University of South Africa (UNISA). The department of education tasked the TSA as a convener to facilitate and organise the process since it was a convener for the Academic programmes in Public Management for the Technikons in South Africa. In the late 1990s, universities had to be responsible for driving their curriculum with more compliance towards policy reforms of the transformation agenda. Universities of Technologies and the other stake-holders in Higher Education were represented in the Advisor Boards and the Governing Bodies (SGPs) to carry the task of designing a new curriculum for the Public Management and Development Programme, which was due to be implemented in 2000 and 2001.

The curriculum development process covered the needs analysis, the designing and registration of the qualifications according to the SAQA requirements and planning for the Implementation and assessment of the programme qualification. In advancing on curriculum reform and restructuring of faculty programmes, the departments in the field of Public Management and Development took the mandate to ensure that the whole process is cascaded from the faculty to the departmental level. The mandate of the departments was to streamline the core curriculum to suit the new requirements of the South African Qualification Authority (SAQA) and the National Qualification Framework (NQF).

The main driving factor was to the processes of implementing the broader transformation goals of the country to have a unified and coordinated HE sector. However, it should be indicated that there were still tendency of the past apartheid regime proliferating on various circles while institutions were endorsing the new curriculum. One of the major policy that impacted on the transformation was the recommendations by the National Council on Higher Education (NCHE) and the National Working Group (NWG) Report on the 'Size and Shape' of Higher Education (2000), The Higher Education Act (1997) and the government's National Plan for Higher Education (2001) which implied that the goals and objectives of the White Paper 3 (1997) on the programme on restructuring of Higher Education, were to be implemented in as far as the participation rate, access and equity targets, diversity of the programmes and staff, the restructuring of the institutions and the research and development capacity. The National Plan on higher education was also endorsed in 2001, and it provided guidelines on how teaching and learning should be informed by the national objectives and respond to national and regional needs.

The Council on Higher Education (CHE) saw a need for promotion of quality in the HE system, and endorsed the existence of the Higher Education Quality Committee (HEQC) mandated by the Higher Education Act (1997) to operate a quality assurance system that focuses on the accreditation of HE programmes and on the audits of the quality management systems of HE institutions. Included in the mandate of the HEQC are the quality promotion and building the capacity of the HE system, institutions and individuals to respond to the HEQCs quality requirements. In reference to the above background, the curriculum reform is a process that cannot be separated from the national goals of transforming HE in South Africa; hence, there are some considerations on the contextual significance of the process of implementation. However, Universities of Technology reviewed their academic programmes with fewer considerations about the defects of the apartheid systems. However, some institutions are facing challenges to up their game by improving teaching infrastructure to implement the new curriculum. This could be a strategic exercise that include the re-incorporating the administrative structures, library resources, the qualification up-grading for some staff members, culture of learning and other resources that can add value in the implementation of the current curriculum.

Notable, some of the considerations for the adoption of a new programme considered at universities and universities of technology, schools and departments in PAM were noted as (The Technikon South Africa, 2001):

- The lack of national goals in HE,
- No common qualification structure which resulted in lacking or deficient in articulation, credit transfer, inter-institutional mobility
- Impermeability of the multi-year qualifications,
- Inequalities within the HE system regarding the learner access and participation,
- Inefficiency and incapability of institutions in responding to the economic and social needs,
- Low throughput rate, which can result to massive financial support by the Department of Higher Education and Training (DHET), and others.

Elaborating of Turkey decentralisation of Public Administration, Sen and Bandyopadhyay (2010:271) assert that Public Administration is at the centre of structure relations between the national, local bodies, and professional associations to up-take a new paradigm of teaching and learning. It should be a priority for policymakers, educators and learners, and other stakeholders to have continues consultative meetings and workshop to address any challenges they experience during the implementation of new curriculum, instead of universities implementing certain provisions of the law in an incremental manner. Lewis and Takahashi (2013) are of the view that curriculum reforms must include the broader society at national and district level, to capture research based lesson studies that are facilitated by universities, feeder schools and associations from the field of study to encourage responsiveness to society needs.

THE SECOND PHASE OF CURRICULUM REFORM

In reference to the new current re-curriculated diploma in PAM, The primary role of the state in implementing the new structure is to create an enabling policy and funding environment, particularly through the HEQSF, HEMIS and the funding framework (CHE, 2013). One unit and the minimum HEQSF credits should increase the subsidy units

allocated to each of the programmes concerned within HEMIS by 120. Thus, general Bachelor's degrees and diplomas would be reconfigured to carry 4 HEMIS units and 480 HEQSF credits. The subsidy units allocated to each of the programmes concerned within HEMIS should be increased by one unit and the minimum HEQSF credits by 120. Thus, general Bachelor's degrees and diplomas would be reconfigured to carry 4 HEMIS units and 480 HEQSF credits.

The second phase of rearticulation was initiated by universities of technology with the guidance of DHET and Council on Higher Education Quality Committee (HEQC). Government played a supervisor role in making sure that the process considered all the requirements and guidelines advised by the HEQC. Institutions conducted needs assessment and their advisory boards, to solicit the core attributes of the academic programmes at national and institutional level. The Curriculum Development process was to cover the needs analysis, the designing and registration of the qualifications according to the SAQA requirements and planning for the Implementation and assessment of the programme qualification. In advancing on curriculum reform and restructuring of faculty programmes, departments and schools in Public Management and Development took the mandate to ensure that there is proper infrastructure available for the implementation of the new curriculum by re-incorporating the administrative factors and the academic resources to ensure better quality of products produced. The purpose of the curriculum reform is part of the national agenda to transform HE in South Africa; also, it came as a response to improve quality in some institutions especially the previously disadvantaged institutions. Schools and departments in PAM removed the year courses and replaced them with Modules. However, the main challenge of the new undergraduate programme was that it is more of public management stream, while universities are offering diverse courses in public administration. This challenged the articulation of students from UoTs undergraduate to university postgraduate studies.

DETERMINANTS FOR DESIGNING AND PLANNING A CURRICULUM FOR UNDERGRADUATE PAM STUDIES

Public Management discipline is one of the disciplines grappling with current change, that imply change in the discipline. According to Stuteville and Click (2016:103), the main challenge of Public Administration and Management (PAM) is the identity crisis since the discipline has struggled to define itself, and it is often positioned between political science and the management sciences. In some other UoTs PAM is housed in the faculty of Humanities and Social Science, while other UoTs have housed it under the Business and Management Faculties. In addition, UoTs have not been developed well to qualify their status and can engage in areas of their core business differently from the culture of former out-structured Technikons. There UoTs that are still practicing sub-standards inherited from the out-structured Technikons. These challenges form a cloud in the branding of programmes offered by the UoTs.

The CHE (2013) proposed that the undergraduate programmes must be flexible and the proposed new curriculum structure must be based on the set of principles designed to make it effective for the full student body. The PMA discipline has responded to some of the following principles:

1. **Fitness for purpose:** The CHE (2013) supports curriculum reform and recommends that it must be able to meet student's needs- and allow for foundational and supportive provision in various forms and at different levels. However, HE conducted curriculum reforms in line with the national agenda for higher education transformation, by considering access and success of student body with various backgrounds. It was also advancing to flexibility when considering the outcomes of each qualification at different exit levels.
2. **Flexibility:** Along with the government, National Plan (2001) goal to improve teaching and learning, and requires curriculum to effectively accommodate various educational background. According to CHE (2013), the curriculum structure must be flexible rather than reflect the assumption that a single set of parameters is appropriate for all students. The PAM departments and institutions provides various support mechanisms to learners that intends to enter HE with qualifications from other institutions. Recognition of higher learning (RPL) is one of the strategies used by universities to generate flexibility in entry points and progression pathways to accommodate different levels of preparedness among entering students. However, qualifications where service learning is required, universities expect the learners to conduct and complete

experiential training at the work place having spent expected hours and credits to complete it and be accredited by the university.

3. **Diversity of pathways and duration:** Curriculum for PMA consider planning and designed with some considerations on resources needed, funding purposes and formal time expressed in academic years for undergraduate qualifications. In the case of distance learning, universities are required to indicate how students can achieve different exit outcomes. Therefore, public administration students need different times to complete a programme, not only because of variation in preparedness but also because contact sessions through full-time study is different from the distance learning. Some of the factors contributing to delays on students' completion of courses include lack of funding and support, lack of interests to further studies and other personal factors.
4. **Design based on the needs of most students:** A qualification must be composed of modules or subjects that are credit bearing for full-time (and the related credit values) specified for qualifications and should concur with the learning needs of the majority of the student intake. In practice, there can be an extension of the studies over a period of one year to accommodate the national performance patterns.
5. **Curriculum must accommodate different levels of preparedness:** The current curriculum in PAM has increased the entry threshold requirements of matriculants who enter tertiary education so that they can survive in their first year at university. This notion is in line with the strategy to retain students by making sure that all students admitted to tertiary institutional programme are able – to follow a curriculum direction that increases their chances of graduating. In some UoTs the unprepared students are admitted first, to do the higher certificate before they get to the main stream.
6. **Exit levels must be maintained or bettered:** The current PAM programme have exit outcomes that are credit bearing and have been prepared in consideration of graduate attributes. During the planning phase of the curriculum, some departments exercised international and national benchmarking to make sure that standards considered quality and are uniform across the sector.
7. **Flexibility in institutional implementation** within a common adoption of the proposal: Different institutions should be free to use the flexible structure differently, provided that this is in accordance with their students' educational needs. In some institutions, virtually all students would follow and benefit from the new curriculum norm, while in others an appreciable proportion of the intake would be able to complete their programme in a shorter time.

Institutions of higher learning proceeded were not all engaged at the same time on such debates about curriculum reforms. The current curriculum incorporated new discourses in Public Administration and Management such as governance and development initiatives. The idea of focusing on the new discourses in the field of study emanates from the stakeholder's pressure to produce competent graduates that can be absorbed by the industry. The table below encompasses the three types of the academic programmes that have restructured from the traditional national diploma in public management to the current diploma in public management and governance.

The first phase of curriculum reform focused on the restructured of the Diploma in Public Administration curriculum stream, offered by UoTs with Public administration as a major and public personnel management and the option of economics as a major also. Most of the out-structured Technikons attracted students who could not be admitted to study Bachelor of Public Administration. This stream was later restructured to the National Diploma in Public Management, majoring in Public Management. However, the national diploma focused more on Public Management, and was later restructured to the Diploma in Public Management and Governance that is currently offered by UoTs. Most of the UoTs recognised that governance should be incorporated to this stream and add more flavour on the flexibility on articulation with less focus on the majors. In the last decade, few universities have begun to offer a limited range of options for students, such as allowing for a delayed decision regarding the student's major and cross-disciplinary majors. However, the current curriculum focus more on the outcomes and graduate attributes that can helping students to be employable after completing their studies. However, the anticipated graduate attributes can pressurise faculties and departments to modify curricula. The attributes can have some merits since they can provide faculty with dynamics for reform. Attributes of the department must be aligned with the university attributes to allow synergy across faculties.

CONCLUSION AND RECOMMENDATIONS

This article demonstrated the relevance of a changing curriculum with reflections on its determinants filtering from compelling external on the national agenda for transformation, PAM disciplinary challenges and boundaries, institutional readiness, CHE and DoE requirements. This article reveals how curriculum reforms involving the undergraduate programmes offered by UoTs can add value to HE as a vehicle for social transformation in South Africa. The analysis wraps up with suggestions on how continuous improvement can be enhanced through academic and practitioners interface. This article suggests that academics in the field of PAM must adopt a multi-disciplinary approach to teaching and learning in the field of PAM informed through research, academic associations, networks and linkages with other international forums in Africa and oversees professional practice in the public sector and academic freedom.

This article recommends that a curriculum development must be strategically planned through a network working by scholars in public administration and management (PAM) through conferences and various colloquiums. The essence of these collaborations is to identify outcomes to be achieved and how to evaluate curriculum proposals per those outcomes. Over the years, UoTs in SA systematically responded to stakeholders needs when designing their curriculum without any formal engagement of scholars abroad and locally to design recirculated accredited programmes in the field of Public Management and Administration (PMA). The aim would have been steered to improve the quality standards that are the pre-determinates of the broader goals of transformation of HE.

Academic in PAM must take a united stand and consider an open debate on decolonisation of curriculum that can be advanced in the field of PAM without excluding the others as if it has been the case in the first phase. However, the path traversed by the universities of technology has demonstrated some merits and demerits in the implementation of the new modularized curriculum. However, under constrained conditions, some of UoTs unconsciously compromised standards and quality on teaching and learning. It is recommended that academics must adopt a pro-active approach in designing curriculum, grounded on principles of accountability, ethical considerations, transparency, responsiveness, inclusion of all the groups including your/ students and disabled people. It is about time that academic conferences accommodate debates on curriculum reforms for scholars to make inputs for shaping both the theory and practice of Public Administration and Management. Not only do conferences provide space for academics and practitioners to present their research, but also valuable academic networks are established and contacts built when academics in the discipline of Public Administration are not fragmented. Public institutions and academics in the field of PAM should make a concerted effort to be part of debates to transform the society in relation to how it should be governed and how the government should govern. These debates can be included on the theories and cases for learning with the intentions to be democratic and socially relevant and promote values such as social justice and deliberations to remove social inequities and gender gap. There is much emphasis on academic accountability at the expense of professional learning and development and is especially felt given that staff feedback can be actively sought over the five years since this curriculum was introduced. It also seems as if academics are left out in such debates, yet motivation should be imperative for their success on Teaching and Learning. There is a need for a further research on how decolonisation can be considered as part of curriculum reforms by Public Administrators in the South African academic landscape.

REFERENCES

- Adegbenga, A.I., & Femi, J. (2015). Critique of Public Administrative Reform System Post-Independence in Nigeria. *Africa's Public Service Delivery & Performance Review*.
- Bakah, A.B., Voogt, J.M., and Pieters, J.M. (2011). Curriculum reform and teachers' training needs: the case of higher education in Ghana. *International Journal of Training and Development* © 2011 Blackwell Publishing Ltd.
- Almqvist, R, Catusu, B., and Skoog, M. (2011). Towards the next generation of public management A study of management control and communication in the Swedish Armed Forces. *International Journal of Public Sector Management* Vol. 24 No. 2, 2011 pp. 122-145.
- Carlos, M. Curriculum Reform in the Faculty of Arts of the Eduardo Mandliane University. Thesis Chapter.
- Dodd-Nufrio, D.N. and Nikitenko, G. 2013. Teaching Public Administration Conference Update. *JPAE* 20 (2), 149 –150.
- Dorasamy, N., and Pillay, S. Addressing learning needs in public management: The value of sustainable partnerships between higher education and public sector institutions in South Africa. *Administratio Publica* | Vol 17 No 3 September 2009.
- Ensor, P. 2002. Curriculum, In N, Cloete, (et.al.eds.) *Transformation in Higher Education. Global Pressures and Local Realities in South Africa*. Lansdowne: Centre for Higher Education in Transformation, pp 270-295.
- Ensor, P. 2004. Contesting discourses in Higher Education Curriculum Restructuring in South Africa. *Higher Education* 48, p339-359.
- FitzGerald, P., & Salim Latib. A Model for Assessing and Shaping Public Service Leadership Development Interventions. *Journal of Public Administration* • Volume 50 • Number 2 • June 2015 249.
- Franks, P. (2014). Crisis of the South African public service. *The Journal of the Helen Suzman Foundation* | ISSUE 74 | November 2014.
- Freire, P. 2000. *The pedagogy of the oppressed*. USA: Bloomsbury Publishing.
- Jones, L.R. 2007. Curriculum development for Public Administration and Management programs in China and Asia: an IPMS dialogue. *International Public Management Review Electronic Journal* at <http://www.ipmr.net> Volume 8 (1). © International Public Management Network.
- Kelly, R. 2010. *Teaching strategies for quality teaching and learning*. Cape Town: Juta publishers.
- Kuye, JO. 2014. A critical re-think of public administration and management in continental Africa. *African Journal of Public Affairs*. Volume 7 number 4 • December 2014.
- Lewis, C., and Takahashi, A. Facilitating curriculum reforms through lesson study. *International Journal for Lesson and Learning Studies* Vol. 2 No. 3, 2013.
- Hubbell, H. & Burt, H. An integrated approach to development and implementing learning centered curricula. *International Journal of Academic Development*. Vol. 9.No. 1, May 2004. Pp.51-56. Milliken & Colohan, G.

Managing Change in Higher Education: Assessing Staff perceptions of the impact of semesterisation. Higher Education in Europe. Xxv. No4. 2000.

Maila, w. 2009. Broadening curriculum as an open-ended inquiry in Higher Education. Curriculum Issues in Higher Education. Conference proceedings from the African Conference on Curriculum Development in Higher Education. UNISA. Pretoria, September 2008.

Mphako-ntusi. 2006. Comprehensive Universities and Universities of Technology in South Africa: Challenges of Research Administration. 2006. Journal of Higher Education.

Mubangisi, B & Theron, F. 2011. Inculcating public leadership for citizen value Reflecting on Public Administration curricula. Administratio Publica | Vol 19 No 1 April 2011.

Ostrom, V., 2008. The intellectual crisis in American public administration. University of Alabama Press.

Peters, M.A., 2013. Managerialism and the neoliberal university: Prospects for new forms of “open Management” in higher education. Contemporary Readings in Law and Social Justice, (1), pp.11-26.

Quintana, B.M.G., and Fernandez, M.S. 2015. A pedagogical model to develop teaching skills: a Collaborative learning experience in the immersive virtual world TYMMI. Computers in Human Behavior 51 (2015) 594–603.

Saadun, S.1 and Lewis, J. 2013. Revisit the Curriculum Components for the Preparation of Health Services Managers. Saadiah Juliana Saadun, 1and Lewis, J. Procedia - Social and Behavioural Sciences 129 (2014) 257 – 265.

Sen, D., Bandyopadhyay, A .2010. Educational decentralization as part of public administration reform in Turkey. Procedia Social and Behavioral Sciences 2 (2010) 269–276.

Siddirtha, S. Diversity on North America planning curricula: The need for Reform. Canadian Journal of Urban Research. Vol. 14. Issue.1. 121-144. 2005.

Stuteville, Rebekkah, and Eric Click. "An Assessment of the Scholarship of Teaching and Learning in Public Administration from 2009-2013." VOLUME 11 A Journal of the Center for Excellence in Teaching and Learning (2016): 102.

Tahmasebi, R. and Musavi, M. Politics-Administration Dichotomy: A Century Debate.

Technikon South Africa. 2001. Recurriculation of the national diploma in public administration. Unpublished workshop reading material. Pretoria: TSA.

Wetburry, I. 2003. Evaluating a national curriculum reform. In Haug, P., and Schwandt, A.T., Evaluating educational reforms: Scandinavian Perspectives. Greenwich: IAP Information Age Publishers.

Weber, Max, "Bureaucracy" in Weber, Max. Weber's Rationalism and Modern Society: New Translations on Politics, Bureaucracy, and Social Stratification. Edited and Translated by Tony Waters and Dagmar.

Waters, 2015. [ISBN 1137373539. English translation of "Bureaucracy" by Max Weber](#)

Wilson, W. (1887). The study of administration. Retrieved on 2nd June 2017 from: <http://www.scholar.google.com>.

THE DEVELOPMENT OF A TALENT RISK MANAGEMENT TOOL FOR ACADEMICS IN SOUTH AFRICAN EDUCATION INSTITUTIONS

Deborah Mokgojwa, Nicolene Barkhuizen and Nico Schutte
North-West University, Mafikeng Campus, South Africa

ABSTRACT

Despite some inroads into the field of talent management, research on talent management risk factors remains scarce. The main objective of this research was to develop a talent risk management tool for academic staff in a selected South African higher education institution. A talent risk management questionnaire was developed and distributed to academic staff members (N=220) in a selected South African higher education institution. Exploratory factor analyses resulted in five talent risk management factors: Institutional strategy, Management Support, Work Environment, Physical Infrastructure and Diversity Practices. All factors showed acceptable reliabilities. Significant differences exist between talent risk management factors and academic staff based on their gender and job level. Recommendations are made.

Keywords: Academics, Higher Education Institutions, Risk Management, Talent Management, Talent Retention.

INTRODUCTION

Talent continues to be a major business risk that needs to be managed (Cascio, 2012). In particular the attraction and retention of talented individuals appear to be one of the most interesting features of an organisation's risk management (Hatun & Preve, 2015). Anaraki-Ardakani and Ganjal (2014) are of the opinion that human resource (HR) risks should be viewed as an opportunity, which if managed effectively, can enable organisations to sustain competitive advantage. Consequently the management of HR risks can be viewed as one of the most important opportunities that talent professionals have to add value to the new higher educational dispensation of South Africa (Meyer, Roodt & Robbins, 2011).

Talent management remains one of the most misunderstood and poorly applied HR practices in the South African workplace (Schutte, Barkhuizen & van der Sluis, 2015). A recent audit by the South African Board of People Practices showed that talent management was the worst performance area across six provinces in South Africa (SABPP, 2017). These results are concerning as the human factor is considered to be at the heart of enterprise risk and enterprise security (Gentile, 2016). According to Cappelli (2009) there are two great risks in talent management. The first type of risk relates to the inherent costs as a result of a mismatch between employees and skills (i.e. skills shortages or oversupply of skills). The second type of talent risk includes the costs of losing talent investments because of the failure to retain employees. In a similar vein Hatun and Preve (2015) define talent risks as a bio-dimensional construct that can be fitted on a two axis space. On the one end is the probability of the occurrence such as the likelihood that a person will leave an organisation. On the other end are the consequences and problems caused by the event such as the loss of productivity when a talented individual leaves.

According to Meyer et al. (2011, p. 4) typical people risks include "company culture, talent shortages and retention, incompetence, employee performance, unethical behaviour, low morale, grievances and disputes, excessive absenteeism, employee wellness, sabotage, workplace violence, as well as noncompliance with industry

and other regulations and laws". Gentile (2016, p. 6) further adds that HR risk management includes tangible areas such as "risks potentially associated with engaging third-party service providers, protection of company data, outright fraud, issues of physical safety, and numerous but less tangible risks to good organizational decision-making that arise from false or incomplete information". Burke (2013) refers to an international behavioural risk study which identified common risk factors among managers, professionals and production line employees such as failure to seek views, lack of attention to details and inability to influence.

The main objective of this research was to develop a talent risk management tool for academic staff in a selected South African higher education institution. South African higher education institutions are currently facing significant challenges in attracting and retaining key and quality academic staff members. A recent study by Lesenyeho, Barkhuizen and Schutte (2017) showed that almost half of early career academics considered quitting their jobs. Studies by Barkhuizen, Schutte and Du Plessis (2017), Theron, Barkhuizen and Du Plessis (2014), Saurombe (2015) and Lesenyeho et al (2017) showed that a lack of talent management practices were the main predictors of academics' turnover intentions in South African higher education institutions. Furthermore a study by Saurombe, Barkhuizen and Schutte (2017) highlighted the importance of talent brand factors such as reputation and image, organisational culture and identity, strategic vision, corporate social responsibility and work and surrounding environment as important for the attraction of potential pool of talented academic staff. Clearly as mentioned by Bekker and Smidt (2016) there is a case for identifying the risks presented by inappropriate or absent HR practices such as talent management. A clear understanding of the factors affecting talent risks and the assessment thereof can assist higher education institutions to develop an effective strategy to manage talent risks more effectively.

RESEARCH DESIGN

Research Approach

A quantitative research approach was followed with surveys distributed to academic staff in a selected South African higher education institution. This design was appropriate to obtain the research objective of the study namely to develop and validate a talent risk management diagnostic tool. A cross-sectional research design was followed whereby the data was collected at one point in time (Field, 2009).

Sampling

The target population for this study was academic staff of a selected South African higher education institution. A total of 320 questionnaires were distributed of which 220 were returned and used for analyses. This represented a 68,8% response rate. Most of the respondents in the sample were male (56,8%), aged between 30 and 49 years (51,1%) and representative of the Black ethnic colour. Most of the participants were in possession of a Masters degree (42,9%), employed on lecturer level (40,9%), had between one and 10 years of work experience in higher education and were employed between 0 to four years in their current position (34,5%).

Permission to execute the study was obtained from the relevant higher educational authorities. The questionnaire was distributed both hard copy and electronically to the respondents. The study was subjected to ethical clearance prior to the execution thereof. Confidentiality was maintained at all times.

Measuring Instrument

A Talent Management Risk questionnaire was developed based on themes that were identified during the initial interviews with management from the higher education institution. The questionnaire consisted of 30 items which measured five talent risk factors: Institutional strategy, Management support, Physical Infrastructure, Diversity Practices and Work Environment. The responses were collected on a six-point likert scale ranging from Strongly Disagree (1) to Strongly Agree (6). The questionnaire was distributed to subject matter experts prior to its distribution to ensure face and content validity.

Data Analyses

Data analyses were carried out with the aid of SPSS software (SPSS, 2017). Descriptive statistics such as means, standard deviations, skewness and kurtosis were used. Exploratory factor analysis was applied to determine the factor structure of the questionnaire. Cronbach Alphas were used to determine the reliability of the measuring instrument and its items. A cut-off point of 0.7 was used as a guideline for acceptable reliabilities (Field, 2009). Multivariate analysis of variance (MANOVA) was used to determine the significance of differences between the talent management risk factors for the demographic groups. MANOVA tests whether mean differences among groups in a combination of dependent variables are likely to have occurred by chance (Field, 2009). When an effect was significant in MANOVA, one-way Analysis of variance (ANOVA) was used to discover which dependent variables had been affected. T-tests were done to assess the differences between the groups in the sample. For purposes of the present research, we used Cohen's (1988, p. 283) guidelines for the interpretation of effect sizes: 0.0099 constitutes a small effect, 0.0588 a medium effect, and 0.1379 is a large effect.

RESULTS

The metric properties of the measurement were first examined. This was done using the Kaiser-Meyer-Olkin (KMO) measure to determine the sampling adequacy and sphericity of the item-correlation matrix, exploratory factor analysis to discover and identify the dimensions of the measurements, and reliability analysis, using Cronbach alpha coefficients, to give the measure of accuracy of the instruments and determine how repeatable the results were. The questionnaire's MSA was 0.830 which, according to the guideline of higher than 0.6, were adequate for factor analysis (Hair, Black, Babin, & Anderson, 2010). The results of the factor analyses are reported next.

Exploratory factor analyses using the Principal Components extraction method was done on the Talent Risk Management questionnaire. From the initial scree plot it was evident that five factors can be extracted. An exploratory factor analyses using varimax rotation was done specifying five underlying factors for the Talent Risk Management questionnaire. The results showed that five factors can be distinguished for the questionnaire and was labelled as follows: Management Support (Factor 1), Institutional Strategy (Factor 2), Diversity Practices (Factor 3), Physical Infrastructure (Factor 4) and Work Environment (Factor 5). The five factors explained 57,184% of the variance of the questionnaire. One item was deleted because of problematic loadings. All items showed acceptable loadings of above 0.40. The results of the Total Variance explained and the rotated component matrix are reported in Table 1 and 2 below.

Table 1: Total Variance explained for the Talent Management Risk questionnaire

Component	Initial Eigenvalues			Extraction Sums of Squared Loadings		
	Total	% of Variance	Cumulative %	Total	% of Variance	Cumulative %
1	8,149	28,100	28,100	8,149	28,100	28,100
2	2,588	8,923	37,024	2,588	8,923	37,024
3	2,419	8,342	45,366	2,419	8,342	45,366
4	1,802	6,215	51,580	1,802	6,215	51,580
5	1,625	5,603	57,184	1,625	5,603	57,184
6	1,185	4,085	61,268			
7	1,154	3,979	65,248			
8	0,940	3,241	68,489			
9	0,864	2,980	71,469			
10	0,798	2,751	74,220			
11	0,791	2,727	76,947			
12	0,693	2,391	79,338			
13	0,644	2,222	81,560			

14	0,512	1,765	83,325			
15	0,497	1,713	85,038			
16	0,484	1,668	86,706			
17	0,453	1,562	88,268			
18	0,418	1,442	89,710			
19	0,377	1,300	91,009			
20	0,365	1,260	92,269			
21	0,332	1,146	93,416			
22	0,324	1,119	94,534			
23	0,287	0,989	95,523			
24	0,283	0,977	96,500			
25	0,267	0,922	97,422			
26	0,242	0,835	98,257			
27	0,190	0,656	98,913			
28	0,172	0,594	99,507			
29	0,143	0,493	100,000			
Extraction Method: Principal Component Analysis.						

Table 2: Rotated Component Matrix for the Talent Culture Risk questionnaire

	Management Support	Institutional Strategy	Diversity Practices	Physical Infrastructure	Work Environment
TRC1	0,651	0,032	0,138	0,075	0,139
TRC2	0,557	0,225	0,149	0,222	0,088
TRC3	0,762	0,07	0,081	0,144	0,123
TRC4	0,803	0,023	0,163	0,005	0,084
TRC5	0,773	0,037	0,09	0,049	0,219
TRC6	0,818	0,106	0,154	0,078	0,089
TRC7	0,731	0,212	0,087	0,198	0,016
TRC8	0,403	0,344	0,117	0,504	-0,113
TRC9	0,205	0,276	0,212	0,61	-0,118
TRC10	0,123	0,209	0,173	0,679	0,023
TRC11	0,18	-0,01	0,083	0,683	0,254
TRC12	0,09	0,159	0,132	0,685	0,291
TRC13	-0,027	0,000	0,000	0,588	0,438
TRC14	0,089	-0,031	0,025	0,423	0,511
TRC15	0,095	0,108	0,109	0,114	0,665
TRC16	0,215	0,139	0,121	-0,027	0,691
TRC17	0,173	0,142	0,124	0,063	0,772
TRC18	0,079	0,115	0,02	0,185	0,696
TRC19	0,099	0,52	-0,043	0,3	0,102
TRC20	0,148	0,632	0,071	0,143	0,034
TRC21	-0,022	0,755	0,054	0,152	0,046
TRC22	0,187	0,724	0,226	0,009	0,111
TRC23	0,123	0,737	0,212	0,013	0,13
TRC24	0,03	0,656	0,198	0,04	0,16
TRC26	0,171	0,394	0,621	0,11	0,016
TRC27	0,219	0,258	0,657	0,174	0,037
TRC28	0,16	0,117	0,749	0,132	0,226
TRC29	0,13	0,032	0,81	0,086	0,117
TRC30	0,137	0,111	0,747	0,082	0,043

The descriptive statistics of the questionnaire are reported in the Table 3 below.

Table 3: Descriptive Statistics of the Questionnaire

	Mean	SD	Strongly Disagree	Disagree	Slightly Disagree	Slightly Agree	Agree	Strongly Agree	α	Skewness	Kurtosis
Institutional Strategy	4,014	0,862	2,80	10,38	16,44	30,91	31,97	7,50	0,809	-0,418	-0,545
Management Support	3,971	1,015	6,10	8,25	17,66	27,99	30,45	9,55	0,884	-0,612	0,176
Work Environment	3,827	0,875	6,23	10,84	17,99	30,32	28,18	6,43	0,792	-0,447	-0,206
Physical Infrastructure	3,930	1,027	5,23	11,82	16,25	25,80	33,30	7,61	0,739	-0,494	-0,477
Diversity	3,991	0,987	3,37	11,01	18,11	27,48	30,48	9,55	0,835	-0,307	-0,624

The results in Table 3 show acceptable to very good reliabilities of above 0,70 for the five factors of the Talent Risk Management questionnaire (see Field, 2009). When looking at the mean scores and mode distribution of the factors it is evident that more than 30% of the sample perceived the five factors as a risk for the higher education institution.

Next Manova Analyses were performed to determine whether there are any significant differences between talent management risks and demographic groups. The results are reported in Table 4 below.

Table 4: Manova Analyses – Talent Management Risks and Demographics

	Value	F	Hypothesis df	Error df	Sig.	Partial Eta Squared
Gender	0,936	2,905 ^b	5,000	213,000	0,015	0,064
Age	0,922	0,864	20,000	697,441	0,635	0,020
Home Language	0,961	.859 ^b	10,000	424,000	0,572	0,020
Ethnicity	0,909	1,373	15,000	582,879	0,155	0,031
Job Level	0,862	1,601	20,000	697,441	0,047	0,037
Qualifications	0,948	0,765	15,000	582,879	0,717	0,018
Years of work experience higher education	0,885	1,310	20,000	697,441	0,164	0,030
Years current job	0,917	0,928	20,000	697,441	0,551	0,022

The results in Table 4 show that significant differences exist between the talent risk management of respondents based on their gender and job level. Post-hoc analyses for gender showed that Male academics experienced significant higher levels of talent management risks relating to Management Support and Work Environment compared to female academics. The effects were small. Post-hoc analyses for gender showed that respondents employed as Full Professors experienced less risks relating to the institutional strategy compared to those employed on lecturer level. The effect was medium.

DISCUSSION AND CONCLUSIONS

The main objective of this research was to develop a talent risk management tool for academic staff in a selected South African higher education institution. The results showed that five distinguishable talent management risk

factors can be identified for academic staff members: Institutional strategy, Management support, Work Environment, Physical Environment and Diversity Practices. As with previous studies the prevalence of these risks were high among academic staff members (see Burke, 2013; Gentile, 2016). The results further showed that significant differences exist between the talent risk management risk factors and demographic groups based on their gender and job level. More research are needed to explain these results.

This research makes important theoretical, methodological and practical contributions. From a theoretical point of view new knowledge was created regarding the talent management risks for academic staff in higher education institutions. This research makes a methodological contribution by presenting a valid and reliable measuring instrument for managing talent risks in higher education institution. Higher education institutions can use this instrument to detect the level of talent management risks for academic staff members. Practically this research highlighted the presence of talent management risks in various areas such as the institutional strategy, level of management support, working and physical environment and diversity practices. The results also detected that lower level employees experience more risks compared to senior level employees. Management should therefore invest in talent management practices that reduce the levels of talent risks for younger and more junior level employees as they are more difficult to attract and retain in higher education institutions.

This research had some limitations. First a cross-sectional research design was followed which implies that the risks were only measured at one point in time. Longitudinal studies are recommended to track talent management risks over longer periods of time to make clearer predictions regarding the attraction and retention of talent. This research was limited to the higher educational sector and can therefore not be generalised to other environments. However the Talent risk management instrument shows some promising results and future studies could benefit by applying this measure in other contexts. Furthermore it is recommended that a mixed method research approach be followed to investigate and explain the results regarding gender and job level differences and talent risk management.

In conclusion, this research investigated an important area of talent management and also presented a useful measuring instrument that can be used to assess talent risks in the workplace. Higher educational management should therefore take note of the talent management risks and implement preventative measures that can reduce the consequences of these risks on talented individuals.

REFERENCES

- Anaraki-Ardakani, D., & Ganjali, A. (2014). Human Resource Risk Management. *Applied mathematics in Engineering, Management and Technology*, 2, 6, 129-142.
- Barkhuizen, E.N., Schutte, N.E., Nagel, L. (2017). Consequences of Talent Management for academic staff in South African Higher Education Institutions. Proceedings of Research World International Conference, Brussels, Belgium, pp. 1 – 6, ISBN: 978-93-86083-34-0
- Becker, K., & Smidt, M. (2016). A risk perspective on human resource management: A review and directions for future research. *Human Resource Management Review*, 26, 2, 149-165.
- Burke, E. (2013). When talent management meets risk management. *Talent Management*, 9, 4, 42-48.
- Cappelli, P. A supply chain model for talent management. *People & Strategy*, 32, 3, 4-7.
- Cascio, W. (2012). Be a ringmaster of risk: Consider Human Resource Strategy as Risk Management. *HR Magazine*, 38-43.
- Cohen, J. (1988). *Statistical power analysis for the behavioral sciences*. (2nd edn.). Orlando, FL: Academic Press.

- Field, A. (2009). *Discovering statistics using SPSS*. (3rd edn.). London: Sage
- Gentile, M.C. The human factor in enterprise security. *People & Strategy*, 9, 1, 6-7.
- Hair, J.F., Black, W.C., Babin, B.J., & Anderson, R.E. (2010). *Multivariate data analysis: A global perspective*. (7th edn.). Upper Saddle River, N Je: Pearson Education.
- Hatum, A., & Preve, L.A. (2015). Managing Talent Risk. *Harvard Deusto Business Research*, 4, 1, 34-45.
- Lesenyeho, D.L., Barkhuizen, E.N., & Schutte, N.E. (2017). Exploring the causal relationship between the antecedents and consequences of talent management for early career academics in South African higher education institutions. Unpublished paper.
- Meyer, M., Roodt, G., & Robbins, M. (2011). Human resources risk management: Governing people risks for improved performance. *SA Journal of Human Resource Management/9(1)*, Art. #366, 12 pages. doi:10.4102/sajhrm.v9i1.366
- SABPP (2017). *HR Audit 2017*. SA Board for People Practices, Johannesburg, South Africa.
- Saurombe, M. (2015). Talent Management as a predictor of positive work-related outcomes for academic staff in a Higher Education Institution. Unpublished Masters Dissertation, Department of Industrial Psychology, North-West University, Mmabatho, South Africa.
- Saurombe, M., Barkhuizen, E.N., & Schutte, N.E. (2017). Management perceptions of a higher educational brand for the attraction of talented academic staff. *SA Journal of Human Resource Management*, 15(0), a831. <https://doi.org/10.4102/sajhrm.v15i0.831>
- Schutte, N., Barkhuizen, N., & Van der Sluis, L. (2015). Exploring the current application of professional competencies in human resource management in the South African context. *SA Journal of Human Resource Management/SA Tydskrif vir Menslikehulpbronbestuur*, 13(1), Art. #724, 9 pages. <http://dx.doi.org/10.4102/sajhrm.v13i1.724>
- SPSS Inc. (2017). *SPSS 24.0 for Windows*. Chicago, IL: Author
- Theron, M., Barkhuizen, E.N., & Du Plessis, Y. (2014). Managing the academic talent void: Investigating factors in academic turnover and retention in South Africa. *South African Journal of Industrial Psychology*, 40, 1, 1-14.

THE ECONOMIC EFFECT OF HARTBEESPOORT DAM AREAS

Matodzi Michael Mokoena, Mmakosha Ingrid Mokgobu and Murembiwa Stanley Mukhola
Tshwane University of Technology, South Africa

ABSTRACT

Hartbeespoort Dam water is the main sources of water for recreational, irrigating crop, and drinking purposes. The study aim was to assess the economically effects around Hartbeespoort Dam area. Sources water were analysed for the microcystins contamination. Economically data around the study area were reviewed. The findings are that crops farming, recreational and drinking water quality are affected by the high concentration of cyanotoxins in water, however, there is significant increases in an economy due to major tourist attraction and the opportunities offered for water activities, mountain sports, aquarium, snake park and cableway. Activities around the Hartbeespoort Dam has positive effect on economy.

Keywords: Hartbeespoort dam water, economic, water contamination, Cyanobacteria.

INTRODUCTION

The Hartbeespoort dam area is situated in the middle of the beautiful Magaliesberg Mountain, which are few kilometres away from South African economically harbour province Gauteng. The 213 m² Hartbeespoort dam water is supplying 130 square km irrigation water schemes and more than 22 000 population around the area with drinking water (Harding et al., 2004). The beauty of the area makes property development to take place in there.

The challenges of the Hartbeespoort dam is that is one of the most water contaminated dam with cyanobacteria in the world (Oberholster and Ashton, 2008). The cyanobacteria which is also known as blue-green algae produce toxins in its surround such as water. The algae grow well in the dam due to the favourable conditions such as warm temperature, calm wind and enough nutrients. South African condition in summer is perfect for the cyanobacteria to grow as it reach the average of 39°C, heavy rain falls that washes fertilizers from agricultural farms into the dam and water calm condition (van Ginkrl, 2011). One contributing factors is the poor waste water sewage in the northern part of Johannesburg that resulted in dark water run into the rivers such as Jukskei and Crocodile river which end up in the dam (Roux and Oelofse, 2010). All these factors contribute on the blooming of the cyanobacteria in the water. During the blooming season the cells become stressed as they compete for the resources, due to this stress the cells release toxins. The acceptable limit of the toxins in drinking water is 1 µg/L. The cells also releases toxins during the dying or decaying off (Gélinas *et al.*, 2014).

Hartbeespoort Dam area is one of the South African areas that is blooming with the businesses of tourists and property developments because of the recreational activities. It is a major tourist attracting and it offers magnificent opportunities for water activities (fishing and boating), mountain sports and variety of other activities such as hiking, yachting, ballooning hang-gliding, parasailing and abseiling. Places of interest include the aquarium, private zoo, Snake Park and a cableway. Hartbeespoort Dam has a number of arts, craft and curio outlets and it is part of the Heritage route to the World Heritage site (Cradle of Humankind) where a variety of historical and cultural interests are to be found (Platinumweekly, 2011).

However, the water used for these activities recreational, farming and fishing, is contaminated with cyanotoxins that are produced by cyanobacteria during the blooming and the decaying seasons, which affect the

quality of the businesses round the dam. Therefore users of this water with toxins are exposed to the health risks toxins (Mokoena et al., 2016). What is not known is how is the quality of water and other activities around this area affect the Hartbeespoort dam area economy.

RESEARCH PROBLEM

The Hartbeespoort dam water is highly contaminated by cyanobacteria toxins as results of nutrients such as phosphate and nitrogen from the northern side of Johannesburg. The Hartbeespoort dam population is increasing, however, the economically effect of contaminated and the reasons of the population increases in not well explained.

AIM AND OBJECTIVES

This study aim to determine the water quality and economically effects of Hartbeespoort dam areas. This was done by assessing the water quality from the sources used by the communities, and then by determine the challenges and benefits in costs of using Hartbeespoort dam water for irrigation and the business around the study area respectively.

METHODS

Study area and sample size

The study took place in the Hartbeespoort dam area which situated in the North-West province of South Africa. The residents of the Meerhof community use the Rand Water supply, and Refentse residents use tank water supplied from the Schoemansville water treatment plant. The residents of Kosmos and Zandfontein use both communal taps and tank supply from Schoemansville water treatment. Households were randomly selected from a cluster group of different settlements around the study area. The study population size was 504 and comprised members of 76 participating households, including Meerhof school pupils; 55 (11%) were <5 years old and 449 (89%) were >5 years old.

Study design

The study design was comprising the quantitative and the desk-top studies.

Quantitative data - Water sample collection

Water samples collected for the study were grouped according to the water-type used. Water samples were collected from the water containers of all participating households as well as from their respective water sources (e.g. communal taps, ground water, tankers and Rand Water), resulting in 183 samples. Water samples were collected between 2012 and 2013 during two seasons, which were the blooming (spring and summer) and decaying (autumn and winter) periods of the cyanobacteria. For households that did not store water, samples were collected from the nearest tap in their yard or kitchen. For communal-tap samples, the water was allowed to run at high pressure for few seconds before collection, and the bag was opened and filled with the water immediately to avoid contaminating the water. During sampling of the stored water containers, the household members were asked if the water had been treated with bleach (NaOCl) and if so, the time that they had treated the stored water. This was necessary in order to assess if the water treatment using bleach at the household level had been at least 30 min prior to sampling because this is the acceptable contact time between the toxins and the chlorine before consuming the water.

Microcystin analysis

After collection of the samples for microcystin analysis, two drops of Lugol's solution was added to each water sample, which was immediately placed in a black plastic bag to prevent exposure to sunlight (Mackie and He, 2005) and stored at 4°C in a cooler box. Upon arriving at the laboratory, 2 ml of each water sample was decanted into an Eppendorf tube and frozen at -80°C until further analysis of the toxins. Analyses for microcystins were performed with the Abraxis Microcystins-ADDA ELISA kit from Toxisolutions in South Africa, following the Abraxis

procedure (PN.520011) using six standard solutions and one control. After mixing, washing and incubating the microcystin solutions, the microtitre plate was placed into the micro-reader to determine the results.

Desk-top data - Economically data around Hartbeespoort Dam

Review data were search in the search engine such as google scholar, yahoo, Science direct using the following keywords: crop farming in Hartbeespoort dam, drinking water, recreational (fishing, swimming and boating), property development, tourism, natural conservation, and smell of cyanobacteria. From the literature review the articles that were not addressing the good and bad of the social-economic of Hartbeespoort dam were excluded. Total of 7790 articles were screened and only 20 articles considered for review in this study.

Statistical analysis

Data were captured using Microsoft Excel Office 2010, and statistical analyses were carried out using STATA 10. Then, data were analysed using percentage, and correlation statistics and the analysis of variance (ANOVA).

Ethical consideration

In all studies involving either human or animal activities, the ethical considerations become the most important factors to be considered in the study plan, and includes the participation of specialist personnel and type of laboratory to analyse the samples and specific materials to be used. The project was submitted to the Tshwane University of Technology (TUT) Ethics Committee and permission was obtained, ref: REC/2012/03/001

RESULTS

HARTBEEAPOORT DAM WATER QUALITY

The Hartbeespoort Dam was primary developed for irrigation purposes, at which more than 80% of water is used for agricultural farming. Water from the Hartbeespoort Dam is also used for drinking by almost all people staying around the dam. The dam is eutrophication and the dominant species is *Microcystis Aerugenous* which produce microcystins. Microcystins were found in almost all the water samples collected from the following water sources, dam (4.3 & 5.0 µg/L), ground water (2,8 & 0.1 µg/L), communal taps (0.0 & 1.4 µg/L) and tank (3.5 & 0.5 µg/L) supplied water sources, in both the blooming and decaying seasons respectively, used by the communities around study area. Most of the studies (Oberholster and Ashton 2008, Roux and Oelofse, 2010) proved that the water is highly contaminated by toxins producing cyanobacteria (Figure 1) that pose a serious challenges of using the water in this dam. Water from the sources still stored in the stored containers at the households level, this is because most of the water sources are not consistent supplying water to the communities. Small screw tops plastic containers of 20 and 25 L are used. The presence of toxins were found in water samples that were stored containers (Figure 2) at household level below the acceptable limit of 1 µg/L except containers Rand Water in decaying season was 1.5 µg/L.

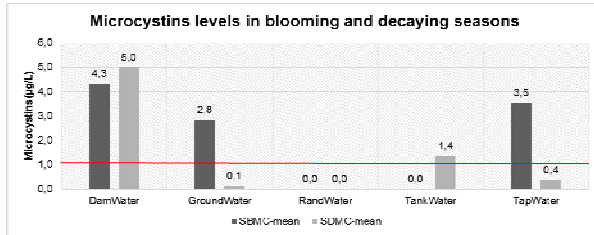

Figure 1: Microcystin data from water sources, grouped by seasons.
SBMC = sources blooming microcystin and
SDMC = sources decaying microcystin

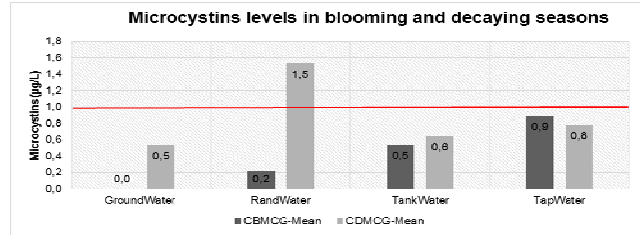

Figure 2: Microcystin data from water containers, grouped by seasons.
CBMCG = containers blooming microcystin and
CDMCG = containers decaying microcystin

The water treatment system is unable to treat enough water to supply the communities with enough water, as currently the Schoemenville water treatment systems treat at least 10 mega litre of water than what is expected which is 15 mega litre as per demand in the blooming seasons. Treated water was proven to have some Microcystins at the point-of-collection which mean water is still exposes people to some of the toxins (Mokoena et al., 2016). Although the piped water supplied from Hartbeespoort dam passes through formal water purification processes that includes filtration and disinfection, there is a risk of certain cyanobacteria related toxins as well as cryptosporidium passing through the treatment works, particularly during periods of high algal growth within the main reservoir. Furthermore residents living close to the irrigation canals and farm workers exposed to irrigation water, as well as recreational users of the dam itself, may be at risk of contracting water related diseases that are associated with microcystins. Toxins in drinking water lead to gastroenteritis, which lead people to use health facilities than usually, while those who can afford they buy their drinking water every day. More money is invested on water and health by the members around area. As saying prevention is better than cure, if more money can be invested in treating water for the community will prevent exposure to cancer promoting and gastroenteritis illness causing toxins Microcystins.

THE CHALLENGES AROUND HARTBEEPOORT DAM AREA.

HARTBEEPOORT DAM AREA

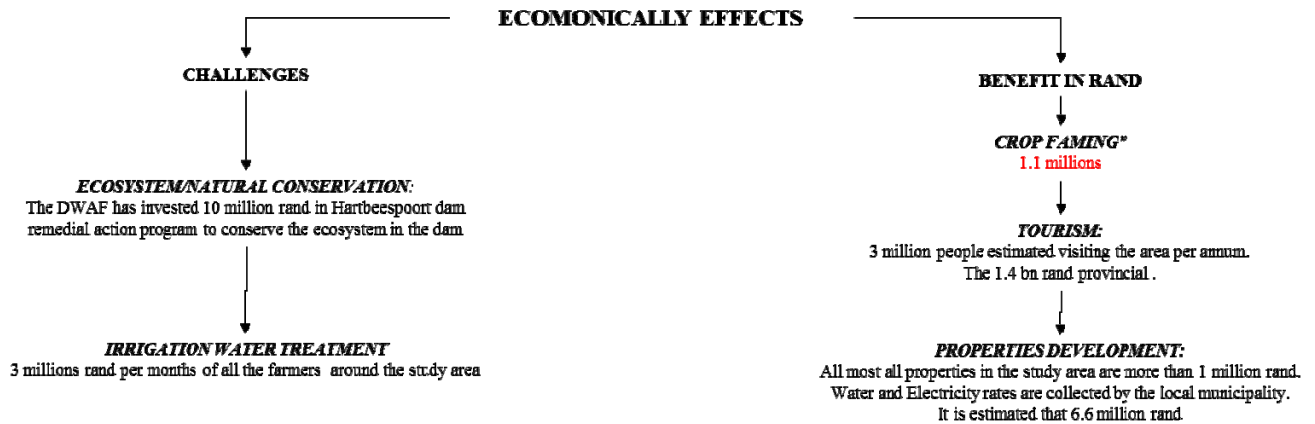

Figure 3: The Hartbeespoort dam economically challenges and benefit

ECOSYSTEM AND NATURAL CONSERVATION

The Hartbeespoort Dam water is one the dam that is highly contaminated by cyanobacteria. The presences of the cyanobacteria is the indication of the highly nutrients that the water body receive through its tributes. This high level of contamination affect the ecosystem such as dying of fish (Wesson, 2016). Some of the species in the dam are affected by the toxins and die off, however, harvested fish exposes toxins to human as they are contaminated. This fish are also in the food chain of either human, birds, or other big fish in the water (Figure 4). The contaminated water by cyanobacteria toxins is also used by human, wild and domestic animals for drinking purposes. Hartbeespoort Dam community members and South African government have introduce hyacinth plant in the dam in order to control the nutrients that are responsible of cyanobacteria blooming such as phosphate and nitrogen. The plant should be at least 15% on the dam on order to allow other activities such as boating and fishing should take place. The government programme which is Hartbeespoort Dam Remedial Action (Metse a me programme) is used to control the ecosystem of the Hartbeespoort dam. More than R10 millions to R900 million has been spent in rehabilitating the species and removing the hyacinth (Harding et al., 2004; Tempelhoff, 2012). Since the government stop funding the Metsi-a-me programme in 2016 the hyacinth had over-growing (van Huizen, 2017). The 30% of the dam is covered with hyacinth (Figure 5). This affect businesses such fishing, boating and other water activities from this dam.

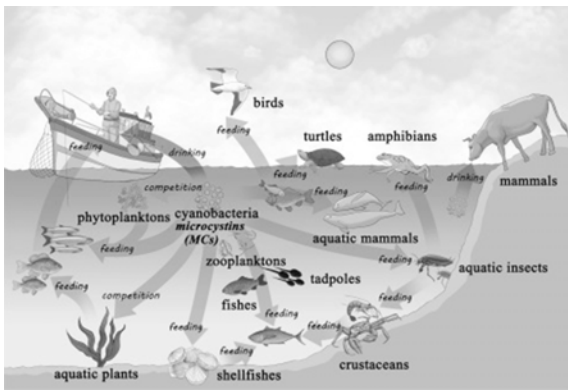

Figure 4: Cyanobacteria microcystin toxins contamination ecosystem cycle in the water (Source Chen et al, 2016)



Figure 5: Hyacinth plant over-growth in the Hartbeespoort Dam (Source: Author, 2017)

TREATING WATER FOR IRRIGATIONS

The Hartbeespoort dam water supply 130 square kilometre downstream water for irrigation schemes. Small and big farmers in the area are forced to use expensive water treatment process before using the water for irrigation. Some of people users reverse osmoses to treat water to irrigate their crops. The system itself is expensive both to buy and maintain. It was found that the farmers around the study area spend more than 3 million rand to use water for irrigation per months at Madibeng municipality (Madibengtime, 2015). Some of the big retailers had pull out their business with the farmers around Hartbeespoort Dam because health issues due to *Escherichia. Coli* and toxins from Hartbeespoort Dam water (Stuijt, 2012). It is demanding for the farm owners to treat Hartbeespoort Dam water for their seedling not to exposure them from the toxins. The effect of not treating their irrigation water is that retails does not buy crops as is contaminated by cyanotoxins. Irrigation water is used for irrigating crops as well as to wash fruit and vegetables when preparing batches for the fresh produce market.

ECONOMICALLY BENEFIT OF HARTBEESPOORT DAM AREA

Crops farming

Crop farming mainly maize and sunflowers should be the main revenue generator of the economy around the study area. However, the monthly generation were found to be 1.1 million less than 50% of the amount used to treat water for irrigation. This challenges have be found that is because of the less market demand of the products. Big business such as Woolworth's retailers has stop buying product because of the presence of *E. coli* and toxins in the crops (Stuijt, 2012).

Tourism

The Hartbeespoort Dam is one of the major tourism destination in North West province. There are different opportunities for tourists, such as recreational activities such as swimming, fishing and boating, mountains and South Africa history. It is estimated that the Hartbeespoort dam area receive 3 million visitors per annum, this tourism business was found to generate 1.4 billion annual in the province (Visser et al., 2002).

Property development

It was reported that more than 46% of property owners earn more than a million rand per annum (Long & Hoogendoorn 2013). Total of 26% owns their businesses. Most people have built their properties as their second homes. This is because that the area is successful developing and there are different opportunities such activities offered in Hartbeespoort dam, tourism, shopping centres and preserved South African history. Hartbeespoort dam and Brits areas are the two main areas that the Madibeng municipality receive revenue monthly. Therefore the Hartbeespoort dam area contribute 6.6 million rand annual to the municipality revenue. Recreation activities increases the demand of the accommodation. This has been seeing by increase of second home owners, guest and lodge houses builder (Long & Hoogendoorn, 2013). Houses near the show line of the dam are affected by the smell produced by the smell of dying cyanobacteria cells which smell like sewage (van Ginkel, 2011), however, this cannot affect the growth of the business such as property development.

CONCLUSION

The presence of cyanotoxins cyanobacteria in the Hartbeespoort dam has high economically effects of the agricultural business as it cost millions to the farmers, who are supposed to clean their water before watering their seedling. Hartbeespoort dam water which is contaminated by either toxins or other bacteria is used to clean the farming final products, this also become health concern for the retailers buying this farm produced. The water challenge livelihood is exposed to health risk from drinking, eating fish, crops irrigated by the water from the dam and tourism is challenged by the smell in decaying seasons. The tourism and property development due to accommodation demand as a results of the tourism and second home owner affect Hartbeespoort dam economy in a positive way.

ACKNOWLEDGEMENT

The following are thanked for their assistance: THRIP/NRF for financial support; Tshwane University of Technology for providing infrastructure, Rand Water Group, Vereeniging, South Africa for kindly supporting this study with the laboratory equipment for the microcystin ELISA analysis.

REFERENCES

- Anderson, D., Glibert, P. & Burkholder, J. (2002). Harmful algal blooms and eutrophication: nutrient sources, composition, and consequences. *Estuaries and Coasts*, 25, (4) 704–726.
- Chen, L., Chen, J., Zhang, X & Xie, P. (2015). A review of reproductive toxicity of microcystins. *Journal of Hazardous materials*. 301, 381-399, <https://doi.org/10.1016/j.jhazmat.2015.08041>.
- Gélinas, M., Fortier, M., Lajeunesse, A., Fournier, M., Gagnon, C., Barnabé, S. & Gagné, F. (2014): Responses of freshwater mussel (*Elliptio complanata*) hemocytes exposed in vitro to crude extracts of *Microcystis aeruginosa* and *Lyngbya wollei*. *Ecotoxicology*, 23, 260-266.
- Harding, W. R., Thornton, J. S., Steyn, G., Panuska, J. & Morrison, I. R. (2004). Hartbeespoort Dam Remediation Project (Phase 1), Final report, Action plan, Volume 1.
- <http://www.iol.co.za/capetimes/news/water-quality-central-to-economic-development-2097415>
- IDEXX. (2000). Coliforms and E. coli 24 hours or Less Quantified Results Manual. Colilert from IDEXX Laboratories. [<http://www.idexx.com/water> Accessed: 11/2006].
- JIN, R.A.R.Z. 2011. Evaluation of field test kits to detect microcystins: 2010 study. Exposure and biomonitoring division. Health Canada.
- Long, D. P. & Hoogendoorn, G. (2013). Second home owners' perceptions of a polluted environment: the case of Hartbeespoort, *South African Geographical Journal*, 95, 1, 91-104, DOI: 10.1080/03736245.2013.806112
- Mackie, T. & He, M. L. (2005). Coeh Project final report: public health impact of the Three Gorges Dam: a preliminary survey of cyanobacteria in the Three Gorges Dam reservoir. PhD thesis, Center for Occupational and Environmental Health and the Pacific Rim Research Program. University of California, Berkeley.
- Madibengtimes, (2015). <http://madibengtimes.co.za/2015/09/09/water-problems-harties-dam-full-with-silt/>
- Mokoena, M. M., Mukhola, M. S. & Okonkwo, O. J. (2016). Hazard assessment of microcystins from the household's drinking water. *Applied Ecology and Environmental Research*, 14, (3), 695-710.
- Oberholster, P. & Ashton, P. J. (2008). State of the Nation Report: An Overview of the Current Status of Water Quality and Eutrophication in South African Rivers and Reservoirs.
- Platinumweek. (2011). Bojanal platinum district municipality scenery, adventure and nature, Platinum weekly, central offices – Postma Street, news@platinumweekly.co.za, <https://platinumweekly.co.za/archives/2011%20Archived%20Newspapers/05%20May/2011%2005%2006%20May/Platinum-Weekly-2011-05-06-May-Page-18.pdf>.
- Roux, S. P. & Oelofse, S. H. H. (2010). The rising costs of both sewage treatment and the production of potable water associated with increasing levels of pollution in a portion of the Crocodile-West Marico water management area. Paper presented at the Conference Proceedings, WISA 2010, Retrieved.
- Stuijt A. (2012). Google censors South African water pollution Hartbeespoort dam. <http://censorbugbear-reports.blogspot.co.za/2012/03/google-censors-sa-water-pollution.html#!/2012/03/google-censors-sa-water-pollution.html>.
- Tempelhoff, E. (2012). (27 December 2012). "Miljoene, maar dam bly nog vuil". Beeld.
- Van Ginkel, C. E. (2011). Eutrophication: Present reality and future challenges for South Africa. Water Research Commission 40-year celebration conference, Kempton Park, *Water SA*, 37, (5) 693-702.

van Huizen D. 2017 Water hyacinth crisis on the Hartbeespoort Dam, <http://kormorant.co.za/30477/watch-water-hyacinth-crisis-hartbeespoort-dam/>

Visser, D., Marfo, C., McLaren, A., Ramatlape, M. & Chadi, A. (2002). Chapter 7: Major industrial and economic activities. In: Mangold S, KALULE-SABITI M and WALMSLEY J. (eds.) State of the Environment Report 2002 North West Province, South Africa. www.nwpg.gov.za/soer/FullReport/industrial.html.

Wesson J, 2016, Ecological disaster threatens Hartbeespoort. Comments from John Wesson on behalf of the Wildlife & Environment Society of SA (WESSA), Birdlife Harties and North West Conservancy Association. <http://kormorant.co.za/26583/ecological-disaster-threatens-hartbeespoort/>

World Health Organization (WHO). (1999). Toxic Cyanobacteria in Water: A Guide To Their Public Health Consequences, Monitoring, and Management. Ingrid Chorus and Jamie Bartram (eds). World Health Organization. Geneva.

ACCOUNTABILITY SESSIONS AFTER QUARTERLY RESULTS ANALYSIS: AN EFFECTIVE STRATEGY FOR EDUCATION TOP MANAGEMENT AND AN IMMENSE TASK TO PRINCIPALS AND EDUCATORS ALIKE

Genesis Molepo, Bongani Khumalo & Andile Mji
Tshwane University of Technology

Keywords: Accounting. Results analysis. Accountability sessions. Educators. Education top management.

ABSTRACT

The purpose was to explore the views of stakeholders on whether accountability sessions held quarterly after the analysis of results are appreciated by all stakeholders. Participants were 63 in all comprising 20 principals, 40 teachers and 3 circuit managers who are considered to be stakeholders in this study. There were 36 women and 27 men whose ages ranged between 25 and 55. Participants indicated their views about accountability sessions on a Likert type scale. Results indicated that three subscales emerged, where participants saw the accountability sessions as there to expose their ineffectiveness; accountability sessions as a good strategy for the improvement of results; the implementation of accountability sessions as being done in a wrong way. Further, in spite of the way the sessions are conducted, they yield good results for the districts. It is recommended that further studies should be conducted to determine the efficacy of the questionnaire and interviews used here in other contexts and samples.

INTRODUCTION

Accountability is a means of interaction in hierarchical, often bureaucratic systems, between those who have power and those who do not. Accountability can be seen as a state of being in which persons is obligated to answer to others. It means answering or accounting for your actions and results. It is something every leader wants more of from his or her team. It may be viewed as one of three critical components to effective empowerment. Empowerment in the work place is by three very important pieces as if supported by a tripod. The three legs of empowerment are responsibility, authority, and accountability (Berkowitz, 2002). Every new task that is handed off to a team needs to be transferred with this balance in mind. The balance can be achieved when a team has a clear understanding of its responsibilities, the authority necessary to fulfill these responsibilities, and the accountability for the consequences of their outcomes (Hursh, 2001). Specifically, accountability is an economic means of interaction (Tymms, 2001). When power is delegated and dispersed to those within a hierarchical system there is an expected return from the investment of that power in others. Those to whom power has been delegated are obligated to answer or render an account of the degree of success in accomplishing the outcomes desired by those in power. It is something every leader wants more of from his or her team. Accountability works as a management tool if the employee knows in advance that she will have to answer for her actions (Bolon, 2001).

THEORETICAL FRAMEWORK ON ACCOUNTABILITY

Managers can practice accountability for positive results by following good performance management principles. The hypothesis in this study is, looking into whether accountability sessions are helping in improving the results of schools. They can use their agencies' performance appraisal programs to establish expectations in employee

performance plans and use formal awards programs to recognize employees (Al-Busaidi, 2005). Being accountable also means being dependable-arriving to work and appointments on time, meeting deadlines, being in the right place at the right time, doing the right thing at the right time. However, merely following the minimum requirements of formal programs is not enough to create the positive environment necessary for constructive accountability (Olson, & Viadero, 2002). Managers need to: involve employees in setting clear, challenging yet attainable goals and objectives, and give them the authority to accomplish those goals; coach employees when they request help, and support employees in all aspects of the job; monitor progress towards goals, and provide feed-back that includes credible, useful performance measures; provide the training and resources employees need to do the work; and recognize employees for good performance, both formally and informally (Marsh, Köller, & Baumert., 2001). Accountability serves as a the guiding principle that defines how we make commitments to one another, how we measure and report our progress, how we interact when things go wrong, how much ownership we take to get things done. Personal accountability at work can encompass everything from employees being accountable for their actions, making themselves indispensable, to managers and people in leadership roles showing personal accountability in order to foster an environment of accountability in the office with their employees (Al-Busaidi, 2005).. The real power of accountability comes when the focus is on taking greater personal accountability for achieving results. That personal accountability manifests itself as greater personal ownership, buy-in, investment and engagement. In a high performance organization team members are individually accountable to each other and mutually accountable to their customers (Berkowitz, 2002). But rather than a negative force, research indicates that holding people accountable for their results has very positive effects: greater accuracy of work, better response to role obligations, more vigilant problem solving, better decision making, more cooperation with co-workers, and higher team satisfaction. If one is not in a management role, demonstrating accountability at work will prove that one is a valuable asset to the company and it will make one an indispensable commodity. Accountability is, in essence, the nerve centre that runs throughout every part of the organization, through every working relationship to every member of every team (Noble, 2001). The bottom line is that accountability means letting your actions rise above your excuses.

Accountability is an odd thing in that workers do their best to avoid it because it has often been used as ammunition for blame or punishment. The paradigm of *individual* accountability is so strong in school cultures that the notion of holding a whole team accountable for its collective outputs confuses school management teams (SMT). To be effective at fostering team accountability and ownership, an organization's systems must be designed with three basic principles in mind. They are: focus, influence, and consequences. In focus, systems for accountability begin with a clear focus and expectations. In a *team* setting, teams need to share a clear mission statement that links directly to the organization's vision (Mitchell, Robinson, Plake, & Knowles, 2001). Building on that mission statement a team should identify its collective outputs and devise systems for measuring their success at efficiently delivering quality products or services. Within the team, each member should be clear of his or her roles and responsibilities including agreements on individual expectations and standards of excellence. The following are strategies for ensuring focus: management has to clearly communicate and continually reinforce the organization's mission and vision since this will make all workers not to lose focus. Require teams to explicitly describe their purpose and outputs that link to the organization's vision. Management should guarantee that teams complete a whole piece of work. Management should see to it that teams explicitly define each member's role and responsibilities (Allen, 2003). Responsibility and accountability are related concepts. If one is responsible for something, one is liable for giving more than just an account of what one have done in respect to it, one is also liable for acting to fulfil that responsibility. Responsibility is a realm of private or public action while accountability is a realm of public justification (Dowdle, 2006). Management has to see to it that teams establish clear standards of excellence for members. Teams have to track and analyze their performance data. Management should also encourage teams to conduct regular business planning sessions.

Figure 1: Basic principles for fostering team accountability and ownership



In influence, teams will also need to be able to influence the operations of these systems. This means workers need to be given as much authority as is reasonable to determine how they achieve the outcomes they have committed to. Holding teams jointly accountable for their combined results, will only work if the people within the team can influence each other's behavior (Jill, 2007). Ideally this implies that team members have what is called "gate control" or control over who joins the team and who stays on the team. At the very least, systems need to be devised such that a team member's feedback carries as much weight as a manager's feedback. This can be affected by instituting a team review process or at least by redesigning one's performance appraisal system to include input from customers and teammates. Strategies for ensuring influence include amongst others allowing employees to participate in the shaping of the organization's mission and vision. Teams should be taught to use performance feedback as the basis for meeting and problem solving sessions. Management has to encourage teams to analyze work practices for improvement and allow teams to act on their improvement ideas. Teams have to be given choice of vendors and budget authority. Management has to ensure that team members regularly give feedback to one another and should empower teams to select new members. Teams should also be empowered to remove non-performers. In consequences, an organization's systems need to close the loop by connecting real consequences to a team's actions. Too often managers shield teams from the consequences of what they do. They field complaints from customers or run interference with other departments. If a team is to be held accountable, then they must handle the results of their own actions together (Jill, 2007). This usually means putting teams in regular contact with their customers, and linking at least a portion of their compensation with their cumulative efforts. It also means the whole team is held accountable for the performance of each member. In a team based organization, coaching and correcting individual performance problems is as much a team responsibility as a management responsibility. For one to ensure consequences, one has to ensure that teams get direct and regular feedback from customers. One should also let teams to carry over savings in their budgets. Internal monopolies have to be abolished. Responsibility, self-empowerment and accountability are keys to taking control of one's success (Galindo, 2009). Rewards and compensation has to be tied to team output and teams should be allowed to share in the financial success of the organization.

While less easy to identify, an organization's culture is just as powerful as its systems in determining how much accountability people will accept (Jill, 2007). While changing an organization's culture is more difficult than tampering with its systems, changing the systems without addressing the cultural aspects could be a waste of time. Creating a culture of accountability means developing a climate in which people can speak openly, admit to mistakes without fear, and worry more about serving the customer than looking better than a co-worker (Coles, 2000). There are several cultural dimensions that can contribute to or discourage accountability. The biggest fear people have about accountability is that they will be punished for their actions. Some organizations realized that blaming people for events that have already occurred does more harm than good. It tends to make people secretive about their actions and competitive with their co-workers. Workers end up looking out for "number one" more than for the success of the organization (Noble, 2001). In successfully accountable organizations, mistakes are celebrated as learning opportunities. The focus is shifted from finger pointing to jointly figuring out how things should be done differently in the future. As a way of encouraging accountability sessions, some teams begins each of its weekly team meetings with a celebration of the week's biggest slip-ups. This technique does not only effectively raised problems and got them solved; it virtually drove fear out of the workplace. Changing from a culture of blame to one

of honest and trusting problem solving usually boils down to the way each worker behaves with each other (Ollman, 2001).

THE SCHOOL CONTEXT AND THE BASIS OF THIS STUDY

The improvement of the quality and levels of educational outcomes in the schooling system is a top priority of both government and the Department of Basic Education (Department of Basic Education 2011). Schools can be held accountable for the performances of their students, but the teachers can too. In the present-day atmosphere of accountability of public institutions, there is an increasing demand for information about the functioning of schools. The end of the year results is used as a yard-stick to see how best the school is (Department of Education, 1996). These as a result make educators and principals to work hard so as to achieve good results. The idea of public accountability expresses a belief that persons with public responsibilities should be answerable to “the people” for the performance of their duties. It is however not possible for schools to always produce the best expected results. This may be the case due to at times lack of resources and lack of skilled labour. The constant changing of the education system also serves to discourage schools in attaining the best results. Schools in the North West province had a problem of matric results not being at an expected level. To improve the results, a lot of strategies were employed and mechanisms were put in place. In the education sector, accountability has never been used as a strategy to help improve the results. It was only used in instances where learners have performed very poorly with the aim of reprimanding the educator responsible for that learning area (Dieltiens, 2005). Amongst the strategies employed, constant accountability sessions were held to track the smooth running of operations. What happened in these accountability sessions is that: at the school level, the SMT after every quarter analyses the results of the whole school. Then all educators are called individually to account for the results. Educators whose learners performed poorly have to account to what the cause is for the poor results (Department of Basic Education 2011). The educator is then asked which remedial actions he is employing to improve on the results. The next step then is that the SMT will also suggest other methods that can be utilised to improve the results. Educators are then encouraged to use these new strategies and at the end of the quarter another meeting will be held that will look into the end of quarter analysis and see as to whether the new strategies helped or not if not the SMT together with the educator decides on new strategies. This is done until the end of the year. The common practice is that the marks improve since educators are held responsible and there is constant supervision and monitoring. From the school level principals and heads of department (HODs) of primary schools then go to the circuit office at the end of every quarter with a complete analysis of the school results. In primary schools it will only be principals, deputy principals and/ HODs. Every school’s results are compared with other schools in the circuit or the area office (AO). This is done openly and the SMT members have to account. The problem with this exercise is that in most instances reasons forwarded by the SMT are rejected and are seen to be of no value. Statements uttered by the education top management may be statements like “... *don’t tell us about the learners....you have to be in charge*” and where a principal complains that the results are due to shortage of educators a statements are like this will come from a circuit manager “...*if you want to see a school with manpower shortage go to school B... and their results are better than yours*” for example. This kind of deliberations make SMT s to feel like the department is not on their side and the whole process is aimed at finding faults and blaming principals and the HODs in particular. Accountability can be seen as an old empowerment tool that through it institutions are able to find out what went wrong or what is it that is done correct. This in a way made educators not to take their work very seriously at times (Department of Basic Education 2011). It was only after the introduction of accountability sessions that educators knew that they had to take their work very seriously. This study looks at the use of accountability sessions as a way of improving the school results and how stakeholders feel about it. The very mention of the word accountability sessions strikes fear in the hearts of many teachers and school leaders, leading to confusion and panic rather than improved student achievement.

METHOD

Participants

The targeted population comprised of teachers, principals and circuit managers from two regions of the North West province. The regions have approximately 348 schools including primary and secondary schools. This means that there were about 348 principals, about 2 100 teachers and approximately 40 circuit managers. To select participants, simple random sampling was used. The first aim was to select a sample of approximately 10% of the schools in the population. The 10% was seen to be an ideal number considering that the population of 348 schools would in essence have meant that there were 2 378 eligible participants. That number of participants would be difficult to reach. In selecting the 10% of the schools, a table of random numbers was used and 13 schools were finally included in the study. Specifically, each school was given a number ranging from 1 to 348. The numbers were then defined in the Research randomizer (2011) which generated different sets, and set 6 was selected. In selecting the 20 schools, this meant that automatically the 20 principals were selected. In selecting teachers from each school, the researcher assigned numbers from 1 to n (where n was the number of teachers in a particular school) and the Research randomizer (2011) was used to select two. Two circuit managers were from one circuit and the other one was from a different circuit. This means that the sample was made up of 63 participants, comprising 20 principals as well as 40 teachers and 3 circuit managers. In this study the word teacher is used for both teachers and HODs. Participation by all individuals was voluntary because the purpose of the study was clearly explained to all possible participants. All questions and queries were addressed to their satisfaction. Examples of questions asked included by participants were: (a) "... will you put my name in your report?" (b) "... will you report what I say to the department of education?" and so on. Following this process, it was indicated to the participants that if they so wished they could decline to participate.

Instrument and procedure

A questionnaire comprising two sections was used to collect data. The first section requested the participants to provide biographical data in terms of age, gender, highest academic qualification and work experience. The second section determined the views of respondents on accountability sessions. Interviews were also used. The aim was for respondents to corroborate the information they gave on questionnaire. In this study both qualitative and quantitative methods of collecting data were utilized. In essence this was a mixed methods study. It is averred that the goal "...of mixed methods research is not to replace either of these approaches but rather to draw from the strengths and minimize the weaknesses of both in single research studies ... " (Johnson, & Onwuegbuzie, 2004, pp. 14 - 15). In a similar vein, it has been pointed out that when the two methods are used in combination, the weakness of one could be balanced by the strength of the other (Breakwell & Millard, 1995). The aim of utilising both qualitative and quantitative methods here was to use these as some form of triangulating findings. This means that one method was used in some aspects of the study to verify and corroborate participants' assertions and views in the other method. A questionnaire comprising two sections was used to collect data.

RESULTS

Biographical data

Participants were 20 principals, 40 teachers and 3 circuit managers. Table 1 shows the biographical data that the participants were requested to provide. It may be observed from the table that the majority of participants were women (57.14%).

Table 1 Biographical information of the participants (N = 63)

Category		N	%
<i>Gender</i>			
Women		36	57.14
Men		27	42.86
<i>Age</i>			
25 – 30		12	19.05
31 – 39		13	20.63
40 +		38	60.32
<i>Highest academic qualification</i>			
Diploma (e.g. Diploma in primary education)		12	19.05
Degree or higher(e.g. B.A. or B.A. Honours)		51	80.95
<i>Position held</i>			
Teacher		40	63.49
Principals		20	31.75
Circuit manager		03	4.76

Participants' ages ranged between 26 years and 55 years. The table also indicates that majority of participants (80.95%) are assumed more learned since their qualifications are a degree or higher. It is also worth noticing that circuit managers make only (4.76%). This is due to the fact that circuit managers manage a very large number of schools.

Deliberations on accountability sessions

Participants were requested to indicate their views on how accountability sessions are conducted. Table 2 shows the frequency distribution and percentages of the participants in terms of their feelings about accountability sessions and the way accountability sessions are conducted.

The table reveals that most of the participants were not happy about how accountability is done in the education fraternity. One can see that majority of respondent 62.5 % educators, 90% principals and all circuit managers are of the opinion that accountability sessions improve performance. It is worth noticing that 67.5% of educators are of the opinion that accountability sessions decrease employee commitment to work. Asked in interviews to corroborate this statement, educators said they felt that the department was not considerate. One stated that "...they keep on changing their syllabus and expect us to do miracles". The results also point out that all educators in the study are of the opinion that accountability sessions are there to expose ineffectiveness of educators and principals. One other catching point in these results is that all educators (100%) and 76.92% of principals are in unison that the implementation of accountability sessions is done in the wrong way. On that score they differ with circuit managers who all (100%) agree that accountability sessions are done in the right way.

Table 2: Frequency distribution and percentages in terms of deliberations on accountability sessions

Accountability sessions	Yes/No N (%)	Educator	Principal	Circuit managers
1. Improve performance,	Yes	25 (62.5)	18 (90)	3 (100)
	No	15 (37.5)	2 (10)	0 (0.0)
2. More employee participation and involvement	Yes	30 (75)	20 (100)	3 (100)
	No	10 (25)	0 (0.0)	0 (0.0)
3. Increased employee commitment to the work,	Yes	13 (32.5)	13 (65)	3 (100)
	No	27 (67.5)	7 (35)	0 (0.0)

4. More creativity and innovation, and	Yes	20 (50)	19 (95)	3 (100)
	No	20 (50)	1 (5)	0 (0.0)
5. Accountability is the foundation for creating a learning organization.	Yes	29 (72.5)	18 (90)	3 (100)
	No	11 (27.5)	2 (10)	0 (0.0)
6. It's about punishment.	Yes	37 (92.5)	18 (90)	0 (0.0)
	No	3 (7.5)	2 (10)	3 (100)
7. Employees being consistent in doing the right thing in all aspects pertaining to their job	Yes	20 (50)	19 (95)	3 (100)
	No	20 (50)	1 (5)	0 (0.0)
8. We are happy about how it is done	Yes	1 (2.5)	2 (10)	3 (100)
	No	39 (97.5)	18 (90)	0 (0.0)
9. It yields expected results	Yes	25 (62.5)	20 (100)	3 (100)
	No	15 (37.5)	0 (0.0)	0 (0.0)
10. Accountability sessions are there to expose ineffectiveness	Yes	40 (100)	13 (65)	3 (100)
	No	0 (0.0)	7 (35)	0 (0.0)
11. Is a good strategy for the improvement of results	Yes	39 (97.5)	11 (84.62)	3 (100)
	No	1 (2.5)	2 (15.38)	0 (0.0)
12. The implementation of accountability sessions is being done in a wrong way.	Yes	40 (100)	10 (76.92)	0 (0.0)
	No	0 (0.0)	3 (23.08)	3 (100)

Asked to corroborate their answers, educators indicated that they felt in a way demeaned because principals “...do not consider contextual factors...they state that we have to look into what is it that we are doing wrong”. This respondent was supported by the other one who said “... it's easy to talk about how we need to be more accountable, but it can be uncomfortable when it is applied to us”. Circuit managers on the other hand indicate that they are in their positions to make a change for the better. They say if they are soft to principals and educators alike during sessions, chances are that their message will be taken lightly and no improvements will be registered.

Discussion

Accountability has become the means of enforcement and control used by states and businesses. The results presented here have shown that the participants were relatively mature individuals most of whom (80.95%) were 30 years or older. They were well educated with 80.95% in possession of a degree or higher qualification. It was reported here that respondents were of the opinion that there are three subscales that emerged. These are that participants saw the accountability sessions as being there to expose their ineffectiveness, accountability sessions as a good strategy for the improvement of results and the implementation of accountability sessions as being done in a wrong way. From the above subscales, one can deduce that all respondents are aware of the importance of accountability sessions. This is seen in their response that they are in unison on the point that accountability sessions are a good strategy for the improvement of results.

One should also remember that specifically, accountability is an economic means of interaction. When power is delegated and dispersed to those within a hierarchical system there is an expected return from the investment of that power in others. That is, the department of education expects a better output from principals and educators alike. Those to whom power has been delegated are obligated to answer or render an account of the degree of success in accomplishing the outcomes desired by those in power. Within systems of accountability delegates of power must answer to some higher authority, in this case the district office but the identity of this authority is obscured when the interests of the public, “the South African people,” are used to obscure the special interests of the few “parents of learners”. Additionally, the complication of the identity of those in power and its purpose i.e., being in the greater good also serves to convince the many of the value of the interests of the few (Ross, 2001).

The implication is that teachers, HODs and principals are accountable to the public, but the higher authority is more specifically the interests of the district. Accountability at school is important to the success of the education system as a whole. Every employee, no matter what level of seniority is equally responsible for aiding in the success of the school. In order to achieve the goals of the school, long and short term, it is important that all people within the schooling work together and share accountability. Employees, who work together towards the same overall goal help their workplace to become more accountable, in turn make the school more productive and efficient. People struggle to be accountable when roles and processes are ambiguous. Removing as much confusion as possible about that is doing what and how they will proceed is an important step. If a team is truly accountable, members will identify gaps, learn new roles and processes, and ultimately build a more capable team (Jill, 2007). Accountability is the foundation for creating a learning organization. If one wants sustainable high-quality processes, one need to be able to see what's working and what isn't – and analyze the cause. To that end, each person needs to honestly say what they knew, what they thought and what they did (or didn't do). One important thing one can do to support a learning atmosphere is to take a systems approach as well as holding individuals accountable. Seek to understand what aspects of the situation have influenced the process, system, culture or circumstances (Galindo, 2009). Even if in schools educators are held accountable, the most important issue with them is that they way in which the sessions are held seems like is done to oppress and not develop educators. Most educators when asked to elaborate on their take on accountability sessions indicated that the attitude that the circuit managers use on them was too punitive. Educators felt that the sessions helped improve but the worrying part was that principals pushed them too hard for the improvement of results. On the other hand principals stated that they had no choice but to make their voices to be heard and be very strict so that the results can improve. They also indicated that the attitude they gave to educators was what they got from the circuit managers. Circuit managers on the other hand indicated that accountability was a non-negotiable thing. As long as one worked for the department, one has to be accountable.

CONCLUSION AND RECOMMENDATIONS

This study has being an eye opener in that researchers we able to know that accountability session are in actual fact helping to improve the results of learners. It also became clear that educators did not appreciate how principals conducted the sessions and the principals on the other hand were not happy about how circuit managers conducted the accountability sessions. What is interesting is that the circuit managers believed that if they changed their approach to be more accommodating, they will not be in a position to get the expected goal of improving the results. It is therefore recommended that these strategies will help leaders and teammates foster a culture of shared accountability. The top management of the department of education should firstly earn the trust of the co-workers. This means doing what you say and saying what you mean all the time. They should also publicly own up to their own mistakes and accept the natural consequences for them. In instances when mistakes or problems occur, they should focus on the future. To correct the problem and prevent it from happening again, management should steer the discussion to what needs to be done next and away from what was done.

Management has to remember that the intention is not the same as performance the management therefore should help their subordinates to follow through on their commitments by regularly checking in on progress. This can be done by simply making old business or ongoing projects a regular agenda item and asking people to share their current status, successes, and need for help. Management has to be explicit about accountability and expectations they have to talk openly and preferably face-to-face about responsibilities, performance standards, deadlines, potential consequences or implications of their actions, etc. the biggest and most important aspect of accountability sessions is that management has to be supportive. Help people talk about their progress on their commitments, and offer help when they are stuck or unsure. Accountability sessions must be understood as developmental by all parties involved.

Limitations

While the sample of this study was randomly selected the results presented here are in no way meant to be generalised to all schools in the North West province for instance. It is worth pointing out that accountability is a vast field of study on its own hence this paper may not be seen as comprehensive in any way. Because of this, the researchers' aim was to illustrate how stakeholders like educators, principals and circuit managers in two districts viewed accountability sessions and if they believed that it was a good strategy for improving results.

REFERENCES

AccountAbility (2003) *AA1000 Assurance Standard*, AccountAbility, London, UK.

Al-Busaidi, H.S. (2005) "The Role of the Corporate Governance System in Improving the Functioning of Company Boards in Oman – Perceptions and Directors", *Masters of Business Administration Dissertation*, Cardiff Business School.

Allen, A. L. (2003). *Why Privacy Isn't Everything: Feminist Reflections on Personal Accountability*. Lanham: Rowman & Littlefield.

Berkowitz, B. (2002). Academic bashing. *Z Magazine*, 15(2), 8-11.

Breakwell, G. & Millard, L. (1995). *Basic evaluation methods: Analysing performance, practice and procedure*. Leicester: The British Psychological Society.

Coles, G. (2000). *Misreading reading: The bad science that hurts children*. Portsmouth, NH: Heinemann.

Department of Basic Education, Basic Education Laws Amendments Act 15 of 2011 of the South African Schools Act No. 84 of 1996. Pretoria: Government Printers, 2011.

Department of Education, *The South African Schools Act No. 84 of 1996*. Pretoria: Government Printers, 1996.

Dieltiens, V., *Transformation of the South African schooling system, the fault-lines in South African school governance: Policy or people?* Braamfontein, Johannesburg: The Centre for Education Policy Development, 2016.

Dowdle, M.W. (2015). *Public Accountability: Design, Dilemmas and Experiences*. Cambridge University Press.

Galindo, L. (2009). The 85% Solution: The buck stops here. *How personal accountability guarantees success. No Nonsense, No Excuses*. H.B. Printing.

Hursh, D. W. (2001). Neoliberalism and the control of teachers, students, and learning: *The rise of standards, standardization and accountability*. *Cultural Logic* [Special issue on "Marxism and Education"], 4(1). Available online: <http://www.eserver.org/clogic/4-1/4-1.html>

Jill, S. (2007). *Corporate Governance and Accountability*. England: John Wiley & Sons.

Johnson, R. B. & Onwuegbuzie, A. J. (2004). Mixed methods research: A research paradigm whose time has come. *Educational Researcher*, 33(7), 14 – 26.

Mitchell, K. J., Robinson, D. Z., Plake, B. S., & Knowles, K. T. (2011). (Eds.) *Testing Teacher Candidates: The Role of Licensure Tests in Improving Teacher Quality*. Washington: National Research Council.

Noble, D. F. (2001). *Digital diploma mills: The automation of higher education*. New York: Monthly Review Press.

Ollman, B. (2011). *How to take an exam and remake the world*. Montreal: Black Rose

Research randomizer. “Random sampling and random assignment have never been easier!” Retrieved April 12, 2014, from <http://www.randomizer.org/>

CITIES TO CITIES INTERNATIONAL RELATIONS: A CASE OF THE CITY OF TSHWANE MUNICIPALITY

John Ntshaupe Molepo
Tshwane University of Technology, South Africa

ABSTRACT

International relation is a complex field, its practice and scope involves numerous role players whether in government or non-governmental organizations. The Constitution of the Republic of South Africa 1996 describes its government as national, provincial and local sphere which are distinctive, interdepend and interrelated. The national and provincial government, by legislative and other measures must support and strengthen the capacity of the municipalities (Local Government) to manage their affairs, to exercise power and to perform their functions. Cities across the world make relationships with other cities. City of Tshwane is like other cities which seek investment opportunities for its citizens. City of Tshwane has several relations with different countries. The paper seeks to examine the impact of the relations, whether are beneficial for the city or not. For the purpose of this paper, the study used qualitative research approach. The views and opinions of the officials were directly and indirectly captured by means of interviews and observations. The study adopted the use of data triangulation approach.

Keywords: international relations, local government.

INTRODUCTION

The primary focus of this paper is international relations in local government and its impact thereof. International relation is considered as an interdisciplinary field of study that focuses on foreign affairs and global issues. International Relations (IR) is a complex field, its practice and scope involves numerous role players whether in government (all spheres), Non-Governmental Organisations (NGO), embassies of external offices based in a country. Taking in to account that in South Africa, the issue of international relations is the province of national government particularly the President and the Minister of International Relations and Cooperation.

Challenges facing local governments vary from political, economic, technological, etc. South Africa as a developing country is posed to a lot of challenges. The United Nations Habitat, indicates that the fundamental problem in most local government are facing especially those managing cities in developing countries , “is the widening gap between the availability of financial resources and municipal expenditures needs”. The UN Habitat report further indicates that one of the main reasons for this increasing fiscal gap is “the rapid growth of urban population, which creates an ever-increasing demand for public services and new public infrastructure and its maintenance”. With these rapid challenges facing local government, the need for municipalities to establish relations that will address their challenges is pivotal and through having international counterpart, sharing good practices with other municipalities through international interactions and exchanges, can change negative perceptions (Harie, 2012) and improves practices and this may lead in to improved service delivery in local government. Harie (2012:2) remarks, “South Africa is increasingly becoming more active in International Relations (IR)”and “local government have not only become international actors, but also development actors as well (Buxbaum, 2014:1), the approach opens up new areas in which international experience can be valuable to municipal international relations.

Cities across the world make relationships with other cities. City of Tshwane (COT) is like other cities which seek investment opportunities for its citizens. City of Tshwane has several relations with different countries. The paper seeks to examine the impact of the relations, whether are beneficial for the city or not.

RESEARCH QUESTION

According to Sim and Wright (2000:17), “the core of any study is a research question which identifies the gap in existing knowledge that the study seeks to fill” and “formulating good research questions can be very difficult (White, 2008:33)” hence research question does not exist in a vacuum (Sim & Wright, 2008) and its important characteristic is to be relevant (Hulley et.al 2011:22).

International relations in local government plays a very fundamental role in ensuring that municipalities shares best practices and create opportunities for each other in view of improving services or lives of the citizens it serves. The relationships of cities are critical and important for the purpose of addressing challenges faced by each municipality. Officials use state resources to travel to other countries in view of establishing relationships with municipalities of those countries. Monies of the municipality are budgeted for and accounted for the purpose of promoting accountability and good governance.

The study focuses on the cities to cities relations with specific reference to the City of Tshwane Metropolitan Municipality. The question relating to extent which cities to cities relations have been addressed in reference to the City of Tshwane Metropolitan Municipality is a matter of extrapolation. The question that the study asks is: what is the nature and scope of cities to cities relations in the City of Tshwane Metropolitan Municipality? Furthermore, the following sub-questions can be asked:

- To what extent does Municipal International Relations enhances development in the City of Tshwane
- How can international relations in local government address challenges of the City of Tshwane?

PURPOSE AND OBJECTIVE OF THE STUDY

The tenacity of the study is to determine the nature and scope cities to cities relations in the City of Tshwane Metropolitan Municipality. Achieving its goal, the study will follow these research objectives:

- To establish the extent to which municipal international relations enhances development in the City of Tshwane;
- To investigate how international relations in local government addresses the challenges faced by the City of Tshwane Metropolitan Municipality.

Concepts of International Relations

According to Goodin (2010:132), theories of realism revolves around four central propositions which are ; states are the central actors in international politics rather than individuals or international organizations, international political system is anarchic as there is no supranational authority that can enforce rules over the states, actors in the international political system are rational as their actions maximize their own self-interest, and all states desire power so that they can ensure their own self-preservation.” Most theorists indicate that international relations is anarchist in nature however Milner (1991:85) argues that the tendency of viewing international relations as anarchist should be put aside but anarchy is an important condition of world politics. Milner (1991:85) further suggest that “strategic interdependence among the actors is at least as fundamental.

There is contention whether international relations are just a field of study or a realm of political practice. Reality is that they represent both as some take international relations as a field of study whiles other believes is

merely on politics. Smit and Snidal (2008:6) indicate that international relations is “an explanatory endeavour, concerned with the “is” of world politics not the “ought”. Chatterjee (2010:5) defines international relations as a “branch of social science is concerned with relations among nations, and other issues like non-state actors, international political economy, security, foreign policies of major powers, globalization, international terrorism, international environment and are studies”.

Cities to Cities Relations

According to (Clark 2009:1) “there is no settled definition of town twinning, neither in law nor culture” but argues that town twinning is one of the modalities of international cooperation at the local level and a further explains that a modality characterized by formal twinning agreements, permanence of relationship and formal recognition by local authorities. Some prefer to use cities to cities relations as town twinning, sister cities relations, partner town or cities relations. For the purpose of this paper, cities to cities relations is used. This relationship can be social, political, and economical.

According to AT Kearney (2012), Global Cities Index based on how the following indicators; business activities (30%); human capital (30%); information exchange (15%); cultural experience (15%) and political engagement (10%) intertwine to determine a city’s global influence and create interrelationships with other cities in linking into the global economy. The first 49 cities are mainly in the Global North; followed by the rising East and a few Latin American go-getters. Cairo, representing Africa, debuts at surveys starting in 2008, when they were at positions 38 and 50 respectively. Nairobi was not surveyed in 2008 and has stayed at 56 in 2010 and 2012; whilst Nigeria started at 53 in 2008 and is now 59 in 2012. So either African cities are generally regressing or not moving as fast as other cities globally”.

Tshwane does not appear on the first 66 cities on the index requiring a lot of work to make an appearance amongst the world’s vibrant, innovative and highly competitive roleplayers. Furthermore, the global cities index also measures performance of emerging cities focusing on some strengths like gross domestic product; middle class growth; infrastructure and ease of doing improvement, as well as vulnerabilities like healthcare deterioration; lack of sufficiently skilled employees and high operational costs, especially wages and unstable industrial relations corruption increase; pollution increase and instability increase. Tshwane will need to be rated so that it builds on the positive foundation of relative strength in the high scoring indicators, and seek to eliminate weaker ones.

Tshwane is fortunate in that after South Africa re-joined the international community in 1994 its diplomatic footprint has grown both in terms of its representatives abroad and those accredited to the country. City of Tshwane is like any other municipalities which seek opportunities for its residents. The City of Tshwane since post 1994 had 18 relationships with different cities in different countries. Their relationships were mainly made because of sharing practices, investment opportunities and encouraging tourism.

Legal framework

International Relations in South Africa rest in national government hence the Department of International Relations and Cooperation’s (DIRCO) focuses, among other things, on consolidating South Africa’s global economic, political and social relations, strengthening the African Agenda and regional integration (<http://www.gov.za/about-sa/international-relations>). According to the *Constitution of the Republic of South Africa 1996*, the president is ultimately responsible for South Africa’s foreign policy and it is the presidents prerogative to appoint heads of South Africa’s diplomatic missions, receive foreign heads of diplomatic missions, conduct inter-state relations and enter into international agreements. The Minister of International Relations and Cooperation (DIRCO) is entrusted with the formulation, promotion, execution and daily conduct of South Africa’s foreign policy. The oversight and accountability in the formulation and conduct of South Africa’s foreign policy are vested in the Parliamentary Portfolio Committee on International Relations and Cooperation, (DIRCO, strategic plan 2015).

“It is no longer possible for municipalities to, in the new millennium, address the variety of issues by simply relying on their internal systems and capacity. A new paradigm is required to enable local government to both deliver on their mandate and to continuously improve its development trajectory at the same time”(Van Rooyen, 2008:17).The need for municipalities to create relations with municipalities in other countries is pivotal. The relations must be beneficial to the advancement of economic issues with desired output of improving services.

The *Constitution of the Republic of South Africa 1996*, in Chapter 3 states that government is constituted as national, provincial and local sphere of government which are distinctive, interdependent and interrelated. Section 154 (1) of the Constitution states that “the national government and provincial governments, by legislative and other measures, must support and strengthen the capacity of the municipalities to manage their own affairs, to exercise powers and to perform their functions”. Section 139 provides provincial government with an authority to intervene in local government and take any appropriate steps deem necessarily to assist particular municipality. The legislative command for local government pretence challenges to the relation between provincial government and municipalities within the province.

The responsibility of negotiating and signing of all international agreements lies with the national executive. Section 231 (2) of the Constitution of the Republic of South Africa provides that an international agreement binds the Republic only after it has been approved by resolution in both National Assembly (NA) and the National Council of Provinces (NCOP), unless it is an agreement referred to in Section 231 (3). An international agreement of a technical, administrative or executive nature, or an agreement which does not require either ratification or accession, entered into by the national executive, binds the Republic without approval by the National Assembly and the National Council of Provinces, but must be tabled in the Assembly and the Council within a reasonable time is captured in Section 231 (3) of the Constitution. Section 231 (4) indicates that any international agreement becomes law in the Republic when it is enacted into law by national legislation; but a self-executing provision of an agreement that has been approved by parliament is law in the Republic unless it is inconsistent with the Constitution or an Act of Parliament. While Section 231 (5) provides that the Republic is bound by international agreements which were binding on the Republic when this Constitution took effect. It is important for any relations made by province or cities in different countries follow the prescripts of the constitution.

BACKGROUND OF THE CITY OF TSHWANE

Municipalities in South Africa are categorized by the *Constitution of the Republic of South Africa, 1996*, as: Category A: A municipality that has exclusive municipal executive and legislative authority in its area (metropolitan municipalities); Category B: A municipality that shares municipal executive and legislative authority in its area with a Category C municipality within whose area it falls (local municipalities); and Category C: A municipality that has municipal executive and legislative authority in an area that includes more than one municipality (district municipalities). The City of Tshwane, which is situated in the Gauteng Province, is a metropolitan municipality or Category A municipality. In 2007, the Demarcation Board (DB) resolved that the boundaries of the City of Tshwane should be changed in line with the proposal of the Board with regards to parts of land within the Metsweding District Municipality (MDM) to be incorporated with the City of Tshwane after the local government elections of 2011 (Integrated Development Plan, (IDP) 2011:02). The metropolitan municipality expanded its capacity from a population of 2 345 908 (Stats SA Community Survey, 2007) after incorporating the MDM. The MDM consisted of Kungwini Local Municipality (KLM) with population of 124 011 (www.kungwini.gov.za) and Nokeng Tsa Taemane Local Municipality (NLM) with population 49 389 (Municipal Demarcation Board Assessment of Capacity for 2008/2009). The new City of Tshwane population is estimated at 2 519 308 (IDP, 2011:19). The City of Tshwane is characterised by a rapidly growing population (a projected annual growth of 41%) because of an increase in immigrants, resulting in an increase in informal settlements (IDP, 2011:20). The City of Tshwane is like any other municipalities which seek to create relations with other municipalities in different countries.

City of Tshwane population has increased significantly and thus requires the City to create more opportunities to its citizens. In 2008, City of Tshwane approved a municipal international relations strategy with an aim to propel and profile City of Tshwane as both a tourist and an investment destination. The strategy also seeks to address the need for improved mechanisms of integration and intergovernmental relations regarding learning and sharing of best practice through international relations. The office of the Executive Mayor is responsible for

establishing, developing and maintaining international relations with various international organizations and cities in targeted countries. The international and intergovernmental unit must provide policy inputs, support and advice and lead line functionaries in their engagement with the outside world, on both bilateral and multilateral level.

It is pivotal for municipalities to strengthen ties with cities that have similar developmental needs. Chapter 5 of the *Local Government Municipal Systems Act, 2000 (Act 32 of 2000)* indicates that there is need for an Integrated Development Plan to be developed is importance as it gives direction for the municipality. *Molepo (2013:3-4)* indicated that “an IDP needs to be developed to ensure that Tshwane strives to achieve the objects of local government set out in section 152 of the *Constitution of the Republic of South Africa, 1996*, which are (i) to provide democratic and accountable government for local communities; (ii) to ensure the provision of services to communities in a sustainable manner; (iii) to promote social and economic development; (iv) to promote a safe and healthy environment; and (v) to encourage the involvement of communities and community organizations in matters of local government”.

METHODOLOGY

The term “research” is defined in different ways. According to Kothari (2011:1) defines research as a “systematized effort to gain new knowledge and some people consider it as a movement, a movement from the known to unknown”. Khan (2011:2) explains research that it has “its origin in a term means to go around or to explore.....” and Khan (2011) further explains research as “a search for facts, answers to questions and solutions to problems”. Miles and Gilbert (2005:1) underpin a score that “research help us to build over more intricate models of the world and how it works, but it also challenges our assumptions and makes us look before we leap”.

Smith (2001:18) underscore a point that the “link between research strategy, that being the design and methods combined, and research question is an important one and can be achieved through a critical approach to research”. According to Wynekoop & Russo (1997:48) a fundamental problem of methodology research is the inconsistency definitions of “methodology” and the failure to define what an author is actually studying. The confusion of the research design and methods should be clarified for the benefit of the academic fraternity as most researchers confuse them. Molepo (2013:9), Maserumule (2011:21) distinguishes “research methodology and research designs because of the fact that research methodologies are often used interchangeably with research designs as if they mean the same”. Babooa (2008:139) describe research design as a “plan, structure and strategy of investigating” and Maxwell (2012:2) argues that “a good research design, is one in which the components work harmoniously together, promotes efficient and successful functioning; a flawed research design leads to poor operation or failure”. Maserumule (2011:21) and Leedy (1993:08) defines research methodology as a “basic procedure, and the steps insolving an unresolved” and “methodology is the philosophical framework within the research is conducted or the foundation upon which is based” (Brown, 2006). O’Leary (2004:85) describes methodology as “the framework which associated with a particular set of paradigmatic assumptions that we will use to conduct our research”.

Creswell (2014: 4) explains the differences between qualitative, qualitative research and mixed methods research starting with qualitative as an “approach for exploring and understanding the meaning individuals or groups ascribe to a social or human problem. The process of research involves emerging questions and procedures, data typically collected in the participant’s setting, data analysis inductively building from particulars to general themes, and the researcher making interpretations of the meaning of data”. Creswell further explains quantitative research as an “approach for testing objective theories by examining the relationship among variables. These variables, in turn, can be measured, typically on instruments, so that numbered data can be analysed using statistical procedures”. Creswell explains mixed methods research as an “approach to inquiry involving collecting both quantitative and qualitative data, integrating the two forms of data and using distinct designs that may involve philosophical assumptions and theoretical frameworks”. And, according to Johnson & Onwuegnuzie (2004) and Hoshmand (2003), “Pragmatism research helps to shed light on how research approaches can be mixed fruitfully” and if research approaches are mixed in the best way, they can offer best opportunities for answering important research questions.

The study used qualitative research methods to examine the implications of cities to cities relations in view of its benefits to the City of Tshwane citizenry. The views and opinions of the officials were directly and indirectly captured by means of interviews and observations. The study adopted the use of triangulation approach. According to Chinomona (2016:76), refers to data triangulation as to the use of multiple sources". The sources used are evidence based including interviews, documents and observation. Convenience sampling which is a non-probability sampling technique was used to select participants. 12 senior officials of the City of Tshwane were interviewed and 7 of the officials are in the Office of the Mayor which is directly dealing with international relations. The researcher had an ample opportunity to engage informally with the previous and current mayor of the City of Tshwane on international relations. Data collection and analysis were done simultaneously. Analyzing data involved categorizing and triangulating evidence from multiple sources.

FINDINGS

The study found that *Change of political leadership* played a huge role in hampering the relations with other cities. The new leadership creates its own vision and mission which do not link with the current agreements and exclude previous agreements. *Party politics* affected the agreements made by the then administration as they want to introduce what is in line with their manifesto. The study found that *the agreements are not punishable if not implemented* as a result, a reluctance will occur from the city. The strategy adopted by the City is not implemented due to budget constraints. The study also found that agreements signed can be achieved over a long period of time and no clear indication of which part of the agreement is achieved. The study found that the City adopted a practice from different City that improved their system of doing things.

CONCLUSION

The need for cities to have relationships with other cities is pivotal in ensuring that the vision of the city which indicates that the need to create investment opportunities be created and such relations need to be maintained and monitored for the purpose of the implementation. The need for other studies needs to be looked into for the possibility of creating a clear modality of creating relations with other cities. Agreements signed with other cities must be implemented for the purpose of fulfilling the objective of the agreement.

REFERENCES

- AT Kearney. 2012. *2012 Global cities index and emerging cities outlook*. AT Kearney Publishers, Korea.
- Babooa, S.K. 2008. *Public participation in the making and implementation of policy in Mauritius with reference to Port Louis` Local Government*. Unpublished thesis. University of South Africa, Pretoria.
- Brown, R.B. 2006. *Doing your dissertation in Business and Management: The reality of Research and Writing*, Sage Publications.
- Buxbaum, G. 2014. *Unpacking Johannesburg`s international city to city partnerships*. Unpublished dissertation, University of Witwatersrand.
- Chatterjee, A. 2010. *International relations today: concepts and applications*. Pearson Education India. Delhi
- Chinomona, e. 2016. Xenophobia and human rights: strengthening the spriti of “Ubuntu” globally. Global Business and Technology Association. Exceeding the vision: innovate, integrate and motivate, Conference proceedings.
- Creswell, J.W. 2014: *Research Design: Qualitative, Quantitative and Mixed Methods Approaches*. SAGE.
- Department of International Relations and Cooperation. 2015. Strategic plan 2015-2020. Pretoria: Government Printer.
- Goodin, R.E. 2010. *The Oxford Handbook of International Relations*. Oxford University Press. Oxford.
- Harie, K. 2012. Municipal international relations. Presentation to Kwazulu-natal technical muniMEC 21 September. SALGA
- Hoshmand, L.T. 2003. Can lessons of history and logical analysis ensure progress in psychological science?. *Theory and Psychology*, 13:39-44
- <http://www.gov.za/about-sa/international-relations>
- <http://www.tshwane.gov.za/AboutTshwane/Pages/Mayorallzimbizo.aspx>
- Hulley, S.B, Cummings,S.R, Bronwer, W.S, Grady, D.G and Newman, T.B. 2011. *Designing clinical research*. 3rd Edition. Lippincott Williams and Wilkins. Riverwoods.
- Johnson, R.B & Onwuegbuzie, A.J. 2004. Mixed methods research: A research paradigm whose time has come. *Educational Researcher*. 33-7 p14-26
- Khan, J.A. 2011. *Research Methodology*. APH Publishing
- Kothari, C.R. 2004. *Research Methodology: Methods and techniques*. New Age International
- Leedy, R.D. 1993. *Practical research planning and design*. New York: Macmillan.
- Maserumule, M.H. 2011. *Good governance in the new partnership for Africa`s development (NEPAD): A public administration perspective*. Unpublished thesis. University of South Africa, Pretoria.
- Maxwell,A.J. 2012: *Qualitative Researcg design: an interactive approach*. Sage Publications

- Miles, J & Gilbert, P. 2005. *A handbook of research methods for clinical and health psychology*. Oxford University Press. USA
- Minler, H. 1991. The assumption of anarchy in International relations theory: a critique. *Review of international Studies*, Vol.17 No.1 pp67-85
- Misuraca, G. 2007. *E-governance in Africa, from theory to action*. A handbook on ICTs for local governance.
- Molepo, J.N. 2013. *Assessing the impact of public participation in enhancing service delivery in the City of Tshwane*. Unpublished dissertation. Tshwane University of Technology. Pretoria
- O'Leary, Z. 2004. *The essential guide to doing research*. Sage
- Ratner, C. 2002. Subjectivity and objectivity in qualitative methodology. *Forum Qualitative: Qualitative Social Research*. 3(3)
- Republic of South Africa. 1996. *Constitution of the Republic of South Africa, 1996*. Pretoria: Government Printer
- Republic of South Africa. 2000. *Local Government Municipal Systems Act, 2000*. Pretoria: Government Printer
- Saunders, M., Lewis, P. & Thornhill,A (2009). *Research methods for business students*. 5th edition.Pearson Education limited.
- Saunders, M., Lewis, P. & Thornhill,A (2012). *Research methods for business students*. 6th edition.Pearson Education limited.
- Sim, J. & Wright, C. 2000. *Research in health care: concepts, designs and methods*. Nelson Thornes now Oxford University Press. USA
- Smit,C.R & Snidal, D. 2008. *The Oxford handbook of International relations*. Oxford University Press. USA
- Swedish International Development Cooperation Agency. 2007. *Urban Development Programme: Municipal Partnerships*. Pretoria: SIPU International.
- Tashakkori, A & Teddlie, C. 1998. *Mixed methodology: combining qualitative and quantitative approaches*. Thousand Oaks. CA: Sage
- United Nations Habitat for better urban future. (NA). *The challenge of local government financing in developing countries*. United Nations Human Settlements Programme (UN-Habitat), the City of Barcelona and the Province of Barcelona. <http://unhabitat.org/the-challenge-of-local-government-financing-in-developing-countries/>
- Van Rooyen, E.J. 2008. Municipal international relations in South African local government. *African Journal of Public Affairs*. Vol 2.1 pg 17
- White, P. 2008. *Developing research questions: a guide for social scientists*: Palgrave Macmillan. London England.
- Wynekoop, J.L & Russo, L.N. 1997. Studying system development methodologies: an examination of research methods. *Information System Journal*. Blackwell Science Ltd.

PARTICULATE MATTER IN PRETORIA WEST, SOUTH AFRICA: LEVELS AND POTENTIAL RISKS FOR HUMAN HEALTH

Oyewale Mayowa Morakinyo, Matlou Ingrid Mokgobu,
Murembiwa Stanley Mukhola
Tshwane University of Technology, South Africa

ABSTRACT

Increase in urbanisation, industrial expansion, and vehicular emissions have continuously introduced solid materials and liquid droplets into the atmosphere thus making urban air unsafe for breathing. Estimation of the levels and potential risks from human exposure to particulate matter (PM) is essential for instituting appropriate mitigation measures. This study assessed the levels of PM₁₀ and its non-carcinogenic risk to the residents of Pretoria West industrial area. The study utilised the year 2016 (January - December) hourly ambient PM₁₀ monitored data recorded for the study area. The hourly, daily, weekly and monthly distribution of the monitored PM₁₀ for the year 2016 were estimated. An estimate of possible health risks to PM₁₀ was done using the US EPA human health risk assessment framework (HQ - hazard quotient). The mean hourly, daily and annual concentration of PM₁₀ in the Pretoria West are 64.52 µg/m³, 54.01 µg/m³, and 47.46 µg/m³ respectively. The highest level of PM₁₀ was recorded at 8:00 am in the morning and 9:00 pm in the evening; highest on Wednesdays and lowest on Sundays; highest in the month of June, and lowest in January and December. The risk of having health related problems from short exposure to PM₁₀ is low (HQ < 1), however, long term exposure may pose some level of risk to sensitive individuals.

Keywords: Particulate matter, Industrial area, Health risks, South Africa.

INTRODUCTION

South Africa is one of the industrialised economies in the Southern Hemisphere (Rorich and Galpin, 1998). It is an arid country with high naturally occurring dust levels, compounded by industrial and vehicular pollution emissions (DEAT, 2010). South Africa often experiences high pollution levels that are injurious to human health in different parts of the country, mostly in large industrial areas such as the South Durban Industrial Basin and the Vaal Triangle (Terblanche *et al.*, 1994). Excessive high PM pollution levels have been observed in industrialised regions and urban areas which contribute up to 30% of particulate pollution in the country (Engelbrecht *et al.*, 2002). Significant associations between exposure to PM and respiratory, cardiovascular and cerebrovascular risks have been reported in South Africa (Wichmann & Voyi, 2012). This study assessed the levels of PM₁₀ and its non-carcinogenic risk to the residents of Pretoria West industrial area.

METHODS

Study area

The study area was in Pretoria West industrial area (25°44'46"S 28°11'17"E). It is an industrial production area with two major power plants and other metallurgical industries.

Data collection and analysis

This study utilised a secondary data obtained from the South African Weather Service. The hourly ambient concentration of PM₁₀ for January to December 2016 was obtained by the originators from a fixed ambient air quality monitoring station.

Exposure assessment

The exposure assessment identifies the population exposed to the hazard, the magnitude, and duration of exposure to the hazard. Our study assumed inhalation as the route of exposure to the monitored pollutants. As previously reported by Matooane and Diab (2003), we computed acute (1-hour), intermediate (24-hour) and chronic (annual) exposure periods for the different exposure groups using the equation:

$$ADD = (C \times IR \times ED) / (BW \times AT) \quad (\text{US EPA, 1988})$$

where *ADD* is the average daily dose of the chemical of interest ($\mu\text{g}/\text{kg}/\text{day}$), *C* is the amount of the chemical in ambient air ($\mu\text{g}/\text{m}^3$), *IR* is the inhalation rate (m^3/day), *ED* is the exposure duration (days), *BW* is the body weight of the exposed group (kg) and *AT* is the averaging time (days).

$$ED (\text{exposure duration}) = ET \times EF \times DE$$

where *ET* is the exposure time (hour/day), *EF* is the exposure frequency (days/year) and *DE* is the duration of exposure (year). The standards for each age group are based on different assumptions, as described by Matooane and Diab (2003) and (US EPA, 1997).

Risk characterisation

Risk characterisation is the quantitative estimation of the health risk of exposure to a pollutant. Here, the non-carcinogenic health effects were expressed as a dimensionless ratio called a hazard quotient (HQ), which indicates the presence or absence of adverse health effects due to exposure (US EPA, 1988).

$$HQ = ADD/REL$$

Where *REL* is the dose at which significant adverse health effects will occur in exposed subjects, compared to an unexposed group.

An HQ of 1.0 is considered to be the benchmark of safety. An HQ that is < 1.0 indicates a negligible risk, while an HQ > 1.0 indicates that there may be some risks to sensitive individuals as a result of exposure.

RESULTS

The mean hourly, daily and annual concentration of PM₁₀ in the Pretoria West are $64.52 \mu\text{g}/\text{m}^3$, $54.01 \mu\text{g}/\text{m}^3$, and $47.46 \mu\text{g}/\text{m}^3$ respectively. The highest level of PM₁₀ was recorded at 8:00 am in the morning and 9:00 pm in the evening; highest on Wednesdays and lowest on Sundays; highest in the month of June, and lowest in December and January.

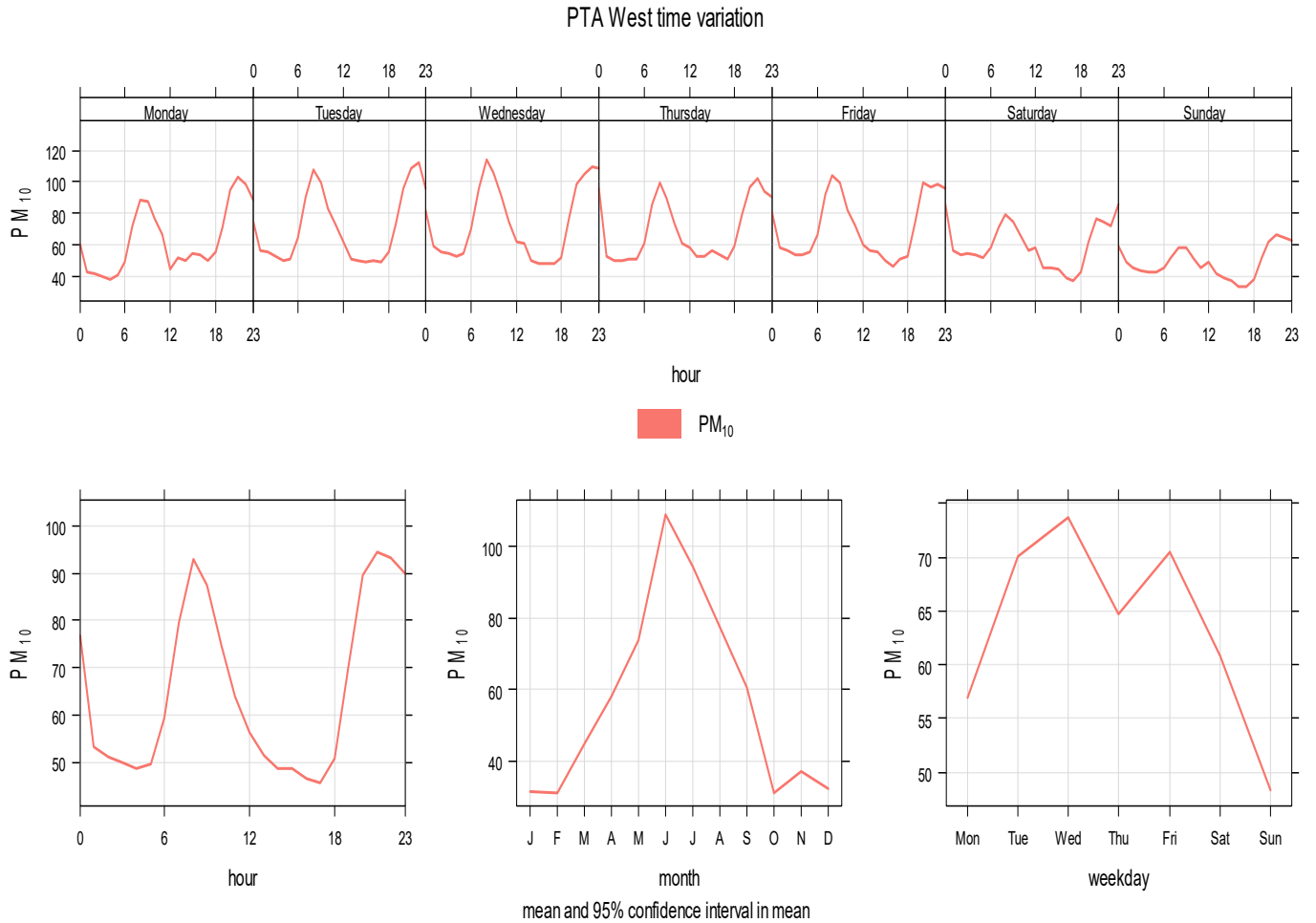

Figure 1: Mean hourly, weekly and monthly distribution of PM_{10}

Table 1: Hazard quotients for exposure to PM_{10}

Exposed group	Exposure	
	Intermediate	Chronic
Infant (Birth to 1 year)	2.0×10^{-2}	1.0×10^1
Child (6 to 12 years)	1.1×10^{-1}	3.62×10^2
Adult (19 to 75 years)	3.0×10^{-2}	2.81×10^2

The HQ from the health risk characterisation from exposure to PM_{10} is provided in Table 1. The results showed that under the normal average and continuous exposures respectively, the risk of having health related problems by the exposed population is low ($HQ < 1$).

For the chronic (annual) exposure scenario, the HQ is > 1.0 for infants, children, and adults. These results show that a sensitive exposed population may be at risk of developing health-related problems from chronic exposure to PM_{10} .

DISCUSSION

Air pollution remains a global environmental threat and a public health risk. Researchers posited that health effects from exposure to ambient air pollution can occur at or below levels allowed by the national and international air quality standards. Findings from our study revealed that the 24-hour PM₁₀ ambient quality standard of 75 µg/m³ was not exceeded on any of the days during the monitoring period. This is in contrast to other studies conducted elsewhere in South Africa. A 24-hour PM₁₀ of 157.37 µg/m³ (highest peak) and 110 µg/m³ was reported by Thabethe *et al.*, (2014) and Matooane and Diab (2003), respectively. The average annual concentration of PM₁₀ recorded in our study was slightly above the guideline limit of 45 µg/m³ set by the NAAQS.

This may account for the chronic (annual) HQ>1 recorded in our study, an indication of some level of risk to long-term exposure to PM₁₀. The low concentration of pollutants recorded in our study may be due to the fact that industries in South Africa are required to submit their emission inventory to regulatory agencies monthly. This may compel these industries to ensure that their emission into the atmosphere is within stipulated guideline limits.

In South Africa, it was estimated that outdoor air pollution was responsible for 3.7% of the national mortality attributable to cancers of the trachea, bronchus and lung in adults aged 30 years and older, and 1.1% of mortality in children under 5 years of age (Thabethe *et al.*, 2014). A review of 12 previous studies in the year 2001 affirmed that a 10 µg/m³ increase in PM₁₀ causes an increase in hospital admissions for congestive heart failure and ischaemic heart disease (Morris, 2001). Among the vulnerable population (older people and those with a previous medical history of respiratory and cardiovascular diseases), long-term exposure to PM₁₀ has been linked to an increase in morbidity and mortality from respiratory and cardiovascular diseases (Hoek *et al.*, 2013). Also for adults, large population studies have shown an association between respiratory (admissions for asthma, COPD and pneumonia) hospitalisation and ambient PM₁₀ (Zanobetti *et al.*, 2009).

CONCLUSION

Ambient air pollution is composed of particulate matter. The acute, intermediate and chronic ambient concentration of PM₁₀ were within the South African National Ambient Air Quality. No health risk was found to be associated with acute and intermediate exposure to PM₁₀. Long term chronic (annual) exposure to PM₁₀ will pose some levels of risks, with the severity of risk differing across groups. We are of the opinion that our study will assist regulators in enforcing or strengthening existing legislation that limits the release of pollutants into the atmosphere.

REFERENCES

- DEAT, Department of Environmental Affairs and Tourism. PM_{2.5} as an emerging priority pollutant in South Africa—impacts on human health. Paper prepared for: Department of Environmental Affairs, Directorate: Information Management, 2010.
- Engelbrecht JP, Swanepoel L, Chow JC, et al. The comparison of source contributions from residential coal and low-smoke fuels, using CMB modeling, in South Africa. *Environ Sci Policy* 2002;5:157–67.
- Hoek G, Krishnan RM, Beelen R, et al. Long-term air pollution exposure and cardio-respiratory mortality: a review. *Environ Health* 2013;12:43.
- Matooane M, Diab R. Health risk assessment for sulfur dioxide pollution in South Durban, South Africa. *Arch Environ Health*. 2003;58:763–70.
- Morris RD. Airborne particulates and hospital admissions for cardiovascular disease: a quantitative review of the evidence. *Environ Health Perspect* 2001;109(Suppl 4):495–500.

Rorich RP, Galpin JS. Air quality in the Mpumalanga Highveld region, South Africa. South Afri J Sci 1998;94:109–14.

Terblanche P., Nel R. & Golding T. 1994. Household energy sources in South Africa: an overview of the impact of air pollution on human health. CSIR Environmental Services, Department of Mineral and Energy Affairs & EMSA, Pretoria.

Thabethe NDL, Engelbrecht JC, Wright CY, et al. Human health risks posed by exposure to PM10 for four life stages in a low socio-economic community in South Africa. Pan Afr Med J 2014;18:206.

US EPA, United States Environmental Protection Agency. Human health risk assessment protocol for hazardous waste combustion facilities, 1988. <http://www.epa.gov/epaoswer/hazwaste/combust/risk.htm>.

US EPA United States Environmental Protection Agency. Exposure factors Handbook, 1997. <http://www.epa.gov/ncea/expofac.htm>.

Wichmann J, Voyi, K. Ambient air pollution exposure and respiratory, cardiovascular and cerebrovascular mortality in Cape Town, South Africa: 2001–2006. Int J Environ Res Public Health. 2012;9:3978–4016.

Zanobetti A, Franklin M, Koutrakis P, et al. Fine particulate air pollution and its components in association with cause-specific emergency admissions. Environ Health 2009;8:58.

ANTECEDENTS OF CITIZENS' ATTITUDE TOWARDS M-GOVERNMENT: AN EMPIRICAL INVESTIGATION

Mercy Mpinganjira
University of Johannesburg, South Africa

ABSTRACT

This paper investigates factors influencing citizens' attitude towards m-government. Data was collected from 380 respondents in South Africa using a structured questionnaire and analysed using version 21 of SPSS. The results show that perceived usefulness, perceived ease of use, trust in mobile technology as a reliable platform for delivering and accessing services, trust in government as an m-service provider as well as prior experience in m-services are all important factors that influence attitude towards m-government. The findings have wide implications on efforts aimed at fostering positive attitude towards m-government and these have been outlined in the paper.

Keywords: m-government, Technology Acceptance Model, trust, South Africa.

INTRODUCTION

The wide spread use of mobile devices, cell phones in particular, is fast re-shaping the face of communication and service delivery around world. Statistical estimates shows that in 2016 mobile-cellular subscription was at 99.7% globally and 80.8% in Africa (ITU, 2017). In South Africa, mobile-cellular subscriptions were estimated at 164.5% in 2015, a jump from 18.6% in 2000 (ITU, 2016). In the wake of high penetration levels of cell phones, government around the world including Africa are fast embracing use of mobile technologies in delivery of public services, a phenomenon widely known as m-government, short form for mobile government. According to the OECD/International Telecommunications Union (2011:12) m-government refers to the 'adoption of mobile technologies to support and enhance government performance and foster a more connected society'. The cell phone is the most widely used mobile device in mobile service delivery although other devices including tablets can be used. A wide range of delivery mechanisms including using Short Message Service (SMS), Multimedia Messaging Service (MMS), calls and Voice over Internet Protocol (VoIP) can be used in mobile service delivery.

M-government, unlike the traditional e-government which relies on internet access, is considered highly beneficial in developing countries mainly because it offers government's easy access to a great number of people (Onashoga et al., 2016). In so doing m-government offers a viable alternative to dealing with the problem of the digital divide particularly in view of the fact that mobile cellular penetration worldwide including Africa permeates social-economic boundaries. The fact that people normally carry their mobile phones all the time, means that public services offered through the mobile platform are accessible to the public at all times and everywhere. Other benefits associated with use of mobile phones to provide public services relate to personalisation and cost-effectiveness. Mobile phones are owned by individual users thereby allowing for easy personalisation of services and targeting of citizens based on needs. The mobile platform is also noted for providing cost saving communication opportunities in that the cost of developing and executing messages is often less than that associated with traditional media such as print, radio or television.

PROBLEM STATEMENT AND RESEARCH OBJECTIVE

While there are many benefits associated with use of mobile technologies in the delivery of government services, the success of such efforts is largely dependent on acceptance of the new channel by members of the public. The OECD/International Telecommunication Union (2011) noted that m-governments' ability to enhance government performance is only possible 'provided the emphasis is not placed on the 'm' but rather on the public sector and the end-users'. Focusing of the end users and e-government in general, UNIPAN (2012) noted the need for governments to come up with strategies aimed at growing public acceptance of the new public service delivery channels. The ability of any government to come up with successful strategies in this regard will depend on its ability to understand the public's opinions regarding the new service delivery channels and the factors that influence such opinions. This paper aims at contributing to this understanding by investigating antecedents to citizens' attitude towards m-government and their behavioural intentions in-terms of making use of m-government services. The focus is on delivery of m-government service delivery by main stream government departments in South Africa through cell-phones. The specific objectives of the study are to (a) examine the relative influence of perceived usefulness, perceived ease of use, trust in mobile technology as a reliable platform for delivering and accessing services, trust in government as an m-service provider as well as prior experience with m-services on attitude towards m-government and (b) to investigate the influence on attitude towards m-government on behavioural intention to use m-government services.

LITERATURE REVIEW

Figure 1 presents the conceptual model used to this study to examine factor influencing attitude towards m-government. Based on the Technology acceptance model (TAM) the conceptual model posits that attitude towards m-government is key to understanding behavioural intentions of citizens to make use of such services. It also posits that attitude towards m-government is influenced by perceived usefulness and perceived ease of use. Furthermore, the model posits that apart from perceived usefulness and perceived ease of use, attitude towards m-government is also influenced by trust in mobile technology as a reliable platform for delivering and accessing services, trust in government as an m-service provider as well as prior experience in m-services.

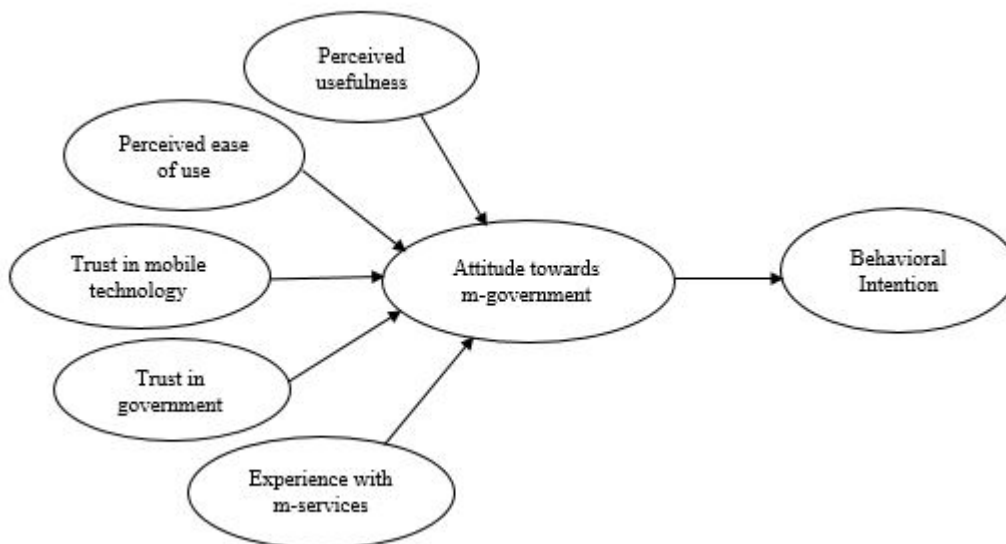

Figure 1: Proposed conceptual model

TAM is one of the most widely used theoretical models in literature to understanding adoption of new technologies. The model stresses the importance of attitudes in understanding technology adoption. Proposed by Davis in 1985, the Technology Acceptance Model was developed in light of organisational concerns that workers were not using information technologies made available to them (Davis, 1989). In response to this, it was reasoned that the best way to improve acceptance of the new information technologies was to investigate people's future intentions regarding use of the technologies and the factors that shaped those intentions. The reasoning was that knowing these factors would allow organisations to easily seek ways of manipulating them so as to promote acceptance and use of new information technologies (Holden and Karsh 2010). Research conducted in this regard showed that people's behavioural intentions to use or not use new information technologies was largely dependent on three important factors namely one's attitude towards the technology, its perceived usefulness and level of perceived ease of use. Thus at the core of the TAM model are these three factors. With its origins in the field of social psychology, TRA stresses the importance of beliefs in explaining attitude as well as the importance of attitudes in explaining behavioural intentions. TAM has been widely applied in empirical research investigating adoption of technologies including investigations into acceptance of e-banking, e-shopping, e-learning and many more (Law et al, (2016). In general TAM is considered to be a robust model that is useful in understanding people's behavioural intentions towards new technologies. It is thus accordingly hypothesised that:

- H1: There is a significant positive relationship between perceived usefulness and attitude towards m-government service delivery.
- H2: There is a significant positive relationship between perceived ease of use and attitude towards m-government service delivery.
- H3: There is a significant positive relationship between attitude towards m-government and intention to make use of m-government services.

While there is wide acceptance of TAM in technology acceptance literature, many scholars argue about the fact that information technologies in the current era, unlike in the 1980's, are characterised by increased networks connectivity and with this, comes increased security risk in that a breach in one system can allow one access to more information than would otherwise be possible. Stories abound of unauthorised people including criminals getting into systems of reputable organisations and the losses including loss to personal privacy that often results from this. Bauer (2005) observed that consumer's often try to minimise risk rather than maximise utility in their decision making. Trust in such cases becomes very important. In looking at trust, one needs to separate trust in technology used to deliver a service and trust in the service provider. This due to the fact that while people may trust an e-service provider such as a bank they may not have a lot of trust in internet as a secure channel to deliver banking services. The service providers' actions can however help reduce people's concerns in using a risky channel to access services. To this end studies have shown that beliefs relating to ability and integrity affect people's willingness to accept e-services including internet banking and online shopping (Mansour et al., 2016). Ashraf et al., (2014) also found the positive influence that trust has on attitude towards use of technologies. It is thus accordingly hypothesised that:

- H4: There is a significant positive relationship between trust in mobile phone technology and attitude towards m-government service delivery.
- H5: There is a significant positive relationship between trust in governments as a service provider and attitude towards m-government service delivery.

Taking into account the fact that private organisations have been on the forefront in adopting use of mobile phones to deliver services, experience in using the mobile channel for accessing other services including banking or for shopping may also help explain differences in people's attitude towards m-government. Bauer (2005:184) noted that 'existing knowledge affects one's cognitive processes as it determines one's ability to understand the features and usage of an innovation'. Jaw et al (2011) found that prior experience with an innovation affects perceived levels of complexity associated with use of similar innovations. It is thus hypothesised in this study that:

- H6: There is a significant positive relationship between prior experience with using the cell phone to access e-services and attitude towards m-government service delivery.

RESEARCH METHODOLOGY

This study was part of a larger study on m-government. The study followed a quantitative research design. Data was collected from 380 members of the general public using a structured questionnaire. All constructs of interest in this paper study were measured using multi-item scales adapted from literature. A five point Likert scale ranging from 1 = strongly disagree, 2 = disagree, 3 = neither disagree nor agree, 4 = agree and 5 = strongly agree was the measure the items. Version 21 of Statistical Package for Social Science (SPSS) was used to analyse the data. Each multi-item construct used in this papers was subjected to reliability analysis before being used in hypothesis testing. The results of the reliability analysis showed that the alpha coefficients ranged from 0.892 to 0.946. According to Field (2009) Cronbach alpha coefficients is the most widely used test in reliability analysis and coefficient values of 0.7 and above are widely accepted as a good indicator that a scale is reliable. The results thus show that all the constructs used in this study were highly reliable.

Table 1 provides details of the demographic profile of the respondents. According to the table there was an almost equal distribution in the respondent's in terms of gender with 49.7 percent of the respondents being male and 50.3 percent of the respondents being female. About half of the respondents 50.5 percent were less than 30 years of age with only 8.4 percent being 50 years and above. In terms of level of education 48.2 percent of the respondents indicated high school or less as the highest level of education attained, 26.1 percent had a diploma while 25.7 had a bachelor's degree or higher. Income wise 43.9 percent of the respondents were low income earners earning a gross monthly income of R5000 or less and only 10.8 percent of the respondents earned R20000 or more.

Table 1: Profile of the respondents

	Frequency	Percent	Cumulative percent
Gender			
Male	189	49.7	49.7
Female	191	50.3	100
Age			
18-29	192	50.5	50.5
30-39	80	21.1	71.6
40-49	76	20.0	91.6
50+	32	8.4	100
Education			
High school or less	183	48.2	48.2
Diploma	99	26.1	74.3
Bachelor's degree or less	98	25.7	100
Income			
R5000 or less	167	43.9	43.9
R5001-R10000	79	20.8	64.7
R10001-R20000	93	24.5	89.2
Over R20000	41	10.8	100

RESULTS

Pearson correlation analysis was used to test the six hypothesis of the study and the results of the analysis are presented in table 2. The results show a significant positive relationship between perceived usefulness and attitude towards m-government ($r = .456, p = <.001$). They also shows perceived ease of use is significantly related to attitude towards m-government ($r = .418, p = <.001$) and that attitude towards m-government is significantly related to behavioral intention to use of m-government services ($r = .644, p = <.001$). Hypothesis 1, 2 and 3 of the study are thus accepted. These results show that the relationships depicted in the Technology Acceptance Model are useful in understanding acceptance of m-government by members of the general public.

The results in table 2 also show that trust in cell-phone technology i.e technology used to deliver m-government services is significantly related to attitude towards m-government ($r = .407, p = <.001$). It also shows a significant positive relationship between trust in provider and attitude towards m-government ($r = .360; p = <.001$) as well as a significant positive relationship between prior experience with other m-services and attitude towards m-government services ($r = .487; p = <.001$). From these results hypothesis 4, 5 and 6 as presented in the paper are accepted.

Table 2: Correlation analysis – attitude towards m-government

		Attitude towards m-government
Perceived usefulness	Pearson correlation	.456**
	Sig (2-tailed)	.000
	N	380
Perceived ease of use	Pearson correlation	.418**
	Sig (2-tailed)	.000
	N	380
Trust in technology	Pearson correlation	.407**
	Sig (2-tailed)	.000
	N	380
Trust in m-service provider	Pearson correlation	.360**
	Sig (2-tailed)	.000
	N	380
Prior Experience	Pearson correlation	.487**
	Sig (2-tailed)	.000
	N	380
Behavioural intentions	Pearson correlation	.644**
	Sig (2-tailed)	.000
	N	380

Field (2009) noted that while the most important criteria in testing whether a significant relationship between two variables exists or not is that the significance value is less than .05, a much lower figure provides more confidence about the strength of effects. The results in table 2 show that the relationships between attitude and the various constructs was not just significant but was significant at much lower levels.

Table 3: Multiple Regression – TAM factors

Model	R	R Square	Adjusted R Square	Std Error of the estimate		
1	.515	.265	.261	.896		
Model	Independent variable	Unstandardised coefficients		Standardised coefficients	t	Sig.
		B	Standard Error			
1	(Constant)	1.584	.181		8.747	.000
	Perceived usefulness	.325	.048	.335	6.794	.000
	Perceived ease of use	.272	.050	.270	5.471	.000

After running the correlation analysis, multiple regression analysis was conducted in order to examine the extent to which the various factors associated with influencing attitude towards m-government actually do so when working together. Two multiple regression models were run with the first one involving Technology Acceptance Model factors of perceived usefulness and perceived ease of use. The second regression analysis involved an extended model that included perceives usefulness, perceived ease of use, trust in cell phone technology, trust in provider and prior experience. Table 3 presents the results of the first regression model. According to the results perceived ease of use and perceived use explained 26.1 percent of the variance in attitude towards m-government (adjusted $R^2 = .261$). In terms of individual contribution of the variables to the regression model, the standardised beta coefficients show that perceived usefulness has more explanatory power over attitude than perceived ease of

use. The standardised beta coefficient value of perceived usefulness was .335 while than of perceived ease of use was .270.

The results of the second multiple regression analysis, presented in table 4 show that by including trust in cellphone technology, trust in provider as well as prior experience to the TAM factors one is able to increase predictive power on attitude. This is evidenced by the fact that the adjusted R² value for the expanded model was found to be higher (.416) than that reported in table 3. It is also important to note that the standardized beta coefficient results of the expanded model show that perceived usefulness still contributed more to explaining attitudes towards m-government (.241) followed by prior experience (.223), trust in cell phone technology (.204), trust in provider (.188) and perceived ease of use (.133).

Table 4: Multiple Regression analysis – Expanded model

Model	R	R Square	Adjusted R Square	Std Error of the estimate		
1	.651	.424	.416	.767		
Model	Independent variable	Unstandardised coefficients		Standardised coefficients	t	Sig.
		B	Standard Error			
1	(Constant)	.536	.198		2.698	.007
	Perceived usefulness	.233	.044	.241	5.288	.000
	Perceived ease of use	.134	.047	.133	2.855	.005
	Trust in provider	.182	.040	.188	4.526	.000
	Trust in technology	.211	.045	.204	4.647	.000
	Prior experience	.205	.043	.223	4.766	.000

DISCUSSIONS AND IMPLICATIONS

According to the findings in this study public attitude towards m-government is dependent of a number of factors including the two critical factors associated with the Technology Acceptance Model namely, perceived usefulness and perceived ease of use. The positive association found between perceived usefulness and attitude as well as between perceived ease of use on attitude, are consistent with results reported by among others Law et al., (2016). The results however show that while perceived usefulness and perceived ease of use are important factors in predicting attitude towards m-government by focusing on additional factors including trust in mobile technology, trust in m-service providers as well as prior experience in other m-services one can increase the predictive ability on attitude. The significant relationship found between attitude and trust in technology as well as trust in e-service provider are consistent with those reported by Ashraf et al., (2014). In terms of prior experience, the findings are consistent with those reported by Jaw et al., (2011). While the results show significant relationship between attitude and all the factors hypothesised in this study to have a positive influence on attitude, the results of the regression analysis show that when considered together, the factors that contribute a lot in explaining attitude are in order of importance perceived usefulness, prior experience and trust in technology. The results also show that attitude exerts strong influence on behavioural intentions to use m-government services.

The findings in this study have wide implications on efforts by government aimed at growing use of Information and Communication Technologies in the delivery of public services. The success of such efforts largely depends on governments' ability to foster positive attitude towards the new delivery channel. This is because of the strong influence that attitude has on behavioural intentions. In trying to foster positive attitude towards m-government, government officials need to pay attention to ensuring that members of the public have access to enough information that will enable them appreciate the benefits associated with m-government and as well as the different ways in while mobile technology can be used to deliver and access public services. With regards to ease of use, officials need to bear in mind that mobile technologies including cell phones are varied in terms of features and capabilities. While some cell-phones may allow people to be able to send and receive pictures including videos or access the internet, others offer basic telephony services as well as the ability to send and receive sms. Often the

more advanced the features and capabilities of a cell-phone the more expensive it is likely to be. Since one the greatest benefits associated with m-government is the ability to easily reach more members of the public than is the case through internet, it is important that government departments learn to make use of basic applications such as sms to deliver and allows access to services. That way government will be able to cater for more people. As diffusion of cell phones with increased capabilities grows among the general population, government can accordingly introduce other advanced applications to their m-service programs. In general, government officials need to have in place measures aimed at ensuring that m-services are available in a way that is accessible and user friendly to many.

Officials also need to pay a lot of attention to building trust in both the suitability of cell-phones as a medium of public service delivery as well as in the government as a provider of the services. Government can improve trust in the suitability of the technology by providing information security assurances to the public and working closely with mobile service providers in ensuring that their systems are secure. When it comes to trust in government as a provider, efforts need to be directed to improving governments' image in terms of ability, goodwill and integrity. In this regard government departments need to ensure that they have enough skilled people to handle both the technical and non-technical side associated with m-service delivery. On the technical side, government needs to look into its IT infrastructure while on the non-technical side emphasis needs to be placed on ensuring satisfactory levels of service using the new channel. Public officers using this channel will need to be trained on factors that impact on m-service quality perceptions including the need for promptness in addressing public demands coming through the mobile channel. In terms of fostering goodwill and integrity, government needs to have in place policies regarding access and use of information delivered using the mobile channel. Measures should be put in place to avoid unauthorised access and use of individual people's personal information.

CONCLUSION

This study examined factors that can be help understand people's attitude towards m-government and their behavioural intentions. While in recent years there has been increased interest by researchers in investigating acceptance of information service systems, acceptance of mobile service delivery has not attracted much attention both in business research as well as in studies focusing on public service delivery. The findings in this study support the need for efforts aimed at fostering positive attitude towards e-government. Such efforts need to focus on ensuring that people are well informed of the benefits associated with m-government so that they can perceive it as being useful, as well as ensuring that people have the necessary knowledge and skills to make use of available services. Governments also need to put in place measures aimed at fostering public trust in use of mobile technologies, in this case cell-phones, to deliver public services as well as trust in government's ability to use mobile technology to deliver satisfactory services to members of the public. Growing use of mobile technology in delivering services particularly by private businesses offers government great opportunities to capitalise on the trend to its benefit as it helps grow the number of people familiar with new service delivery platform, and this exerts significant positive influence on attitude towards m-government.

While the findings of this study are useful in understanding attitudes towards m-government services, the study is not without limitations. Some of the limitations relate to the fact that the sample used was drawn from Gauteng which is a highly urbanised province in South Africa. Future studies can look into investigating similar constructs on a sample of respondents drawn primarily for rural or semi-urban areas. Such studies can help examine differences if any in attitude and drivers of attitude towards m-government. Another limitation related to the cross-sectional nature of the study which makes it not possible to observe changes in attitude over time. Future studies can look at the possibility of conducting longitudinal studies in order to deal with this limitation. Despite these limitations, the study provides a good basis on which officials can develop programs promoting acceptance of m-government services.

Acknowledgement

This material is based upon work supported financially by the National Research Foundation. Any opinion, findings and conclusions or recommendations expressed in this material are those of the author and therefore the NRF does not accept any liability in regard thereto.

REFERENCES

- Ashraf, A. R., Thongpapanl, N., & Auh, S. (2014). The application of the technology acceptance model under different cultural contexts: The case of online shopping adoption. *Journal of International Marketing*, 22(3), 68-93.
- Bauer, H., Reichardt, T., Barnes, S. , & Neumann, M. (2005). Driving consumer acceptance of mobile marketing: A theoretical framework and empirical study. *Journal of Electronic Commerce Research*, 6(3), 181–192.
- Davis F. D. (1989). Perceived usefulness, perceived ease of use, and user acceptance of information technology. *MIS Quarterly*, 13:319–39.
- Field, A. (2009). *Discovering statistics using SPSS*. 3rd edition. London: Sage.
- Holden, R. J., & Karsh, B. T. (2010). Methodological Review: The Technology Acceptance Model: Its past and its future in health care. *Journal of Biomedical Informatics*, 43(1), 159-172.
- International Telecommunication Union (2017). Key 2005-2016 ICT data for the world by geographic regions and by level of development. [Online] Available at: <http://www.itu.int/en/ITU-D/Statistics/Pages/stat/default.aspx>, [Accessed 12th March 2017].
- International Telecommunication Union (2016). Mobile-cellular subscriptions. [Online] Available at: <http://www.itu.int/en/ITU-D/Statistics/Pages/stat/default.aspx>; [Accessed 12th March 2017].
- Jaw, C., Yu, O. S., & Gehrt, K. C. (2011). Integrating user perception and experience into the technology acceptance model: An empirical investigation of online payment service innovation. In *Technology Management Conference (ITMC), 2011 IEEE International*, pp. 134-143). IEEE, San Jose, CA (USA).
- Law, M., Kwok, R. C. W., & Ng, M. (2016). An extended online purchase intention model for middle-aged online users. *Electronic Commerce Research and Applications*, 20, 132-146.
- Mansour, K. (2016). An analysis of business' acceptance of internet banking: an integration of e-trust to the TAM. *Journal of Business & Industrial Marketing*, 31(8), 982-994.
- OECD/International Telecommunication Union (2011) *M-Government: Mobile Technology for responsive governments and connected societies*, OECD publishing. [Online] Available at: http://www.oecd-ilibrary.org/governance/m-government-mobile-technologies-for-responsive-governments-and-connected-societies_9789264118706-en [Accessed 10th March 2017].
- Onashoga, A., Ogunjobi, A., Ibharalu, T. and Lawal, O. (2016). A secure framework for SMS-based service delivery in m-government using a multicast encryption scheme. *African Journal of Science, Technology, Innovation and Development*, 8(3), pp.247-255.
- UNIPAN (2012). *United Nations E-government Survey 2012: E-government for the people*, United Nations, New York.

THE INFLUENCE OF PERCEIVED SHOPPING VALUE ON ONLINE STORE REVISIT INTENTIONS

Mercy Mpinganjira
University of Johannesburg, South Africa

ABSTRACT

This study is investigates perceived online shopping value and its influence on attitude and on intentions to revisit the stores. A structured questionnaire was used to collect data from 201 online shoppers in South Africa. The results show that customers derive both utilitarian and hedonic value from shopping online. Perceived shopping value was found to have positive influence on customers' attitude towards online stores and on intention to revisit the stores. The findings point to need for managers to ensure that they appeal to their customers' utilitarian and hedonic shopping motives in order to return them.

Keywords: Online shopping, utilitarian value, hedonic value, attitude towards online store, intention to revisit.

INTRODUCTION

The concept of perceived customer value is of major interest to marketing practitioners as well as researchers. This is mainly because perceived value is known to be critical to understanding customer behaviour as well as behavioural intentions (Sarkar, 2011).

Core to enhancing customer value is the need to increase benefits and decrease costs associated with derive from purchase behaviours. In trying to find ways of maximising benefits of shopping, researchers have over the years focused their efforts on, among other things, the need to understanding customers' motives behind going shopping. Typologies have often been developed to help understand different types of shoppers based on their shopping motives. While different authors have come up with different typologies Kim and Eastin (2011) observed that in general most typologies suggest that broadly customer values based on shopping motivations can be either cognitive or affective. They further noted that the cognitive motivations are widely referred to as utilitarian while the affective motivations are referred to as hedonic. Dawson et al. (1990) noted that different shopping orientations are associated with unique sets of benefits and retailers attributes that customers seek. A Personal Shopping Value scale developed by Babin et al. (1994) shows that hedonic shopping value is associated with the need to satisfy emotional needs for an enjoyable and highly interesting shopping experience while utilitarian shopping value is associated with convenience seeking and efficiency in shopping.

A good understanding by retailers of how customers of different shopping orientations perceive their stores in relation to sought shopping benefits can be helpful in ensuring development of retailing strategies that are effective in maximising shopping benefits that accrue to customers. A review of literature shows that studies done in relation to understanding customers perceived shopping value have been done mostly in relation to physical retail stores. The advent of the internet has however greatly revolutionised the way retailing in conducted in today's world. The need for retail managers to understand online customer shopping value perceptions for effective retail store strategy development can thus not be overemphasised. This study contributes to this understanding by investigating online shoppers' perceived online shopping values and the influence these have on attitude towards specific online stores as well on their future behavioural intentions to revisit the stores. It does this using a sample of online shoppers drawn from a developing country South Africa. As most studies on online shopping are based on samples drawn from countries outside of Africa, this study contributes to literature on value perceptions in online shopping from a different context.

The paper is structured such that the next section presents a review of literature relating to shopping orientation and shopping values. Also presented in the section are the proposed hypotheses tested in the study. This is followed by a discussion of the study's methodology and presentation of findings respectively. Thereafter the findings in the study are discussed and their managerial implications outlined. The last section of the paper presents conclusions drawn from the findings and provides suggestions for future research.

LITERATURE REVIEW

Utilitarian and Hedonic Shopping Values

According to Hirschman (1984) shopping experiences involve stimulation of an individual's senses and thoughts. He argued that for this reason shopping needs to be viewed as an activity that provides one with affective and cognitive experiences. Retailers widely accept the fact that customers evaluate their shopping experiences based on the cognitive/utilitarian as well as affective/hedonic benefits derived. While customers may derive both utilitarian and hedonic benefits from shopping, research points to the fact that customers may differ in the way they value the two types of benefits. Researchers note that customers can be more utilitarian or hedonic in their orientation (Kim et al. 2011). Customers who are more utilitarian are known to view shopping as a task that needs to be completed as fast and as efficiently as possible (Babin et al. 1994). Büttner et al. (2013) noted that utilitarian shoppers are also commonly known to view shopping as a task requiring a rational approach to it. Customers who are hedonic in their shopping orientation on the other hand are known to be driven more by affective benefits of shopping. They see shopping as more than a means to product acquisition and are known to enjoy it even when not accompanied by actual product purchase (Olsen and Skallerud, 2011). According to Babin et al. (1994) hedonic value is reflected in the pleasure and emotional worth of shopping.

Studies on online shopping often outline convenience and shopping efficiency as its main benefits (Jiang et al. 2013). Unlike physical retailing, online shopping provides customers with an opportunity to buy products around the clock and from any place. Online shopping is thus highly beneficial to time pressed consumers as it gives them the opportunity to save on shopping time. When it comes to effort saving, of concern is the minimisation of cognitive, physical as well as emotional activities that consumers must bear in purchasing products (Berry et al. 2002). Online retailing makes it easy for retailers to provide detailed information to customers about their products than is possible with physical retailing (Tontini, 2016). Another way in which online shopping helps reduce shopping effort is by making it easy for customers to compare competitors' offers. While with physical shopping one need to physically move from one shop to another in order to compare offers, with online shopping this is done at the click of the button.

While the major benefits of online shopping are consistent with utilitarian shopping values. Kemp (2013) remarked that online store designers are increasingly able to come up with online stores that also offer high levels of hedonic value through emotional appeal to customers. The growing use of social sites by online stores for example, offers online shoppers with opportunities to engage with other people including fellow customers and retailers' personnel on a variety of product and other shopping related topics. Though in a different way, online customers are thus able to socially engage with other people while shopping online thereby deriving more hedonic shopping benefits.

Shopping Value, Customer attitude and Behavioural Intentions

According to Abdul-Muhmin (2010) ensuring customers' positive attitude towards a retail outlet is at the core of retailers marketing efforts. This is because positive attitude is known to have desirable business consequences including willingness to revisit of retail store in future. It is important for retailers to understand customer needs before they can have any hope of favourably influencing their attitude towards their stores. According to the Theory of Planned Behaviour proposed by Ajzen (1991) levels of perceived benefits exerts significant influence on peoples' attitudes. Since utilitarian and hedonic values are considered to be important benefits that customers derive from

shopping, a retailer's ability to provide them can help explain customers' attitude towards the retailer as well as a retail store irrespective of whether it is online or offline. Jones et al. (2006) note that utilitarian and hedonic values as important driving forces behind shopping decisions are important to understanding customers' evaluation of a retail outlet. Overby and Lee (2006) found that customers shopping value perceptions have significant influence on levels of satisfaction with a retailer. Chiu et al. (2014) found that perceived value also has positive influence on customers' re-purchase behavioural intentions. While shopping value has been found in some studies to have significant direct influence on behavioural intentions, attitude may be an important mediator of the relationship. The Theory of Planned Behaviour mentions that perceived benefits affects behavioural intentions through its influence on attitude.

Based on findings in literature the study proposes the following hypotheses:

- H1: Levels of perceived utilitarian value have significant positive influence on online customer's attitude towards an online store.
- H2: Levels of perceived hedonic value have significant positive influence on online customer attitude towards an online store.
- H3: There is a positive relationship between levels of perceived utilitarian shopping value and online customers' behavioural intentions to revisit an online store
- H4: There is a positive relationship between levels of perceived hedonic shopping value and online customers behavioural intentions to revisit an online store
- H5: There is a significant relationship between online customers' attitudes towards an online store and behavioural intention to revisit the store.
- H6: Online customers' attitude towards an online store is a significant mediator between perceived utilitarian value and behavioural intentions to revisit the store.
- H7: Online customers' attitude towards an online store is a significant mediator between perceived hedonic value and behavioural intentions to revisit the store.

METHODOLOGY

This study is part of a larger study targeted at online customers from Gauteng, South Africa. Since no list of online customers was available to be used as sampling frame, the study made use of non-probability sampling technique to select respondents. In selecting the respondents however care was taken to ensure that both male and female online customers were well represented. The respondents were approached by research assistants and requested to complete a self-filling questionnaire that looked at different aspects relating to online shopping. By the end of the data collection period, a total of 201 completed questionnaires were received.

Constructs of interest in this study include perceived utilitarian and perceived hedonic value associated with shopping at a specific online store, attitude towards online store and behavioural intentions to revisit the store. Items used to measure perceived utilitarian and hedonic value were adapted from studies by Babin et al. (1994) and Ryu et al (2010). Items used to measure online customers attitude towards online store were adapted from Chen and Wells (1999) as well as Nusair and Parsa (2011) while items used to measure as well as behavioural intentions were adapted from Zeithaml et al. (1996) and Gounaris et al. (2010). Respondents were asked to answer the questions keeping in mind a specific online store. The question items were measured using a 5 point Likert scale. The scale ranged from 1 = strongly disagree to 5 = strongly agree.

The data was analysed using Structural Equation Modelling (SEM). SPSS/AMOS version 21 was used to conduct the analysis. The analysis followed a two stage approach. The first stage involved the assessment of the reliability and validity of the constructs in the measurement model. This involved running confirmatory factor analysis on four constructs and 12 indicators variables. The second stage entailed testing of the proposed hypotheses.

RESULTS

Measurement Model – Assessment of Construct Reliability and Validity

Construct reliability was assessed using the composite reliability coefficients (CR). As shown in table 1, all the factors in the measurement model were found to have composite reliability coefficients of above the recommended 0.70 (Hair et al., 210). Specifically, the composite reliability value of utilitarian value, hedonic value, store satisfaction and behavioural intention to revisit store was found to be .794; .872; .857 and .845 respectively.

Table 1: Construct Reliability and Convergent Validity

	Factor Loadings	CR
<i>Utilitarian value</i>		
Using this website helps increase my shopping productivity	.854	.794
Using this site helps increase my shopping efficiency	.900	
Using this site helps me do my shopping quickly	.724	
<i>Hedonic value</i>		
The website creates a shopping experience that is enjoyable	.843	.872
The website creates a shopping experience that is interesting	.825	
The website creates a shopping experience that is pleasurable	.700	
<i>Attitude towards online store</i>		
I like this online store	.737	.857
Compared with other websites, I would rank this one as one of the best	.765	
This is a good online store	.823	
<i>Intention to revisit</i>		
I am likely to revisit this site in the near future	.809	.845
I intend to revisit this site in future	.930	
I will revisit this site in future	.852	

Validity assessment involved testing for convergent validity and discriminant validity of the measures. Average variance extracted (AVE) and factor loadings were used to assess convergent validity of the constructs. According to Hair et al (2010) AVE's and factor loadings of 0.5 and above respectively are an indication of adequate convergence. The results in table 2 show that the AVE's of all the four constructs were above 0.5. They also show that all the indicator variables had loadings of greater than .70 on their respective factors. These results thus provide evidence of convergent validity for the four constructs of interest in this study.

Table 2: Descriptive Statistics and Validity Statistics

Construct	Mean	Std. Deviation	1	2	3	4
1. Utilitarian value	4.04	.712	.754			
2. Hedonic value	4.19	.683	.698**	.835		
3. Attitude towards online store	4.24	.656	.593**	.605**	.817	
4. Intention to revisit	4.32	.648	.579**	.602**	.591**	.806
Average Variance Extracted			.569	.697	.667	.649
Maximum Shared Variance			.487	.487	.366	.362
Average Shared Variance			.391	.405	.356	.349
Note: 1. **. Correlation is significant at the 0.01 level (2-tailed).						
2. Diagonal values in bold are the square root of the AVE. Off diagonal values are construct correlations						

Discriminant validity was tested by comparing the average variance extracted of individual factors with the shared variances between factors as well as by comparing the square root of the average variance extracted with the

absolute correlation values between factors. According to Hair et al., (2010) discriminant validity is supported when the average variance extracted for each factor is greater than its shared variance with other factors. Hair et al., (2010) notes that both the maximum shared variance (MSV) and average shared variance (ASV) need to be less than the AVE for discriminant validity to be supported. Discriminant validity is also evident when the square root of the AVE is greater than the absolute correlation values between factors. The results in table 2 show that the two conditions associated with discriminant validity were met. AVE for all the constructs were greater than their associated maximum shared variance as well as average shared variance. They also show that the square root of the AVEs were greater than the correlation coefficients associated with each factor. The results thus provide support evidence of discriminant validity.

Assessment of Structural model

The structural model in the study was assessed for goodness of fit so as check how well it models the data. The results showed that the structural model demonstrated good fit to the data as per recommendation by Hair et al. (2010). Specifically, the chi-square (χ^2) was found to be 62.18 with 30 degrees of freedom and was statistically significant ($p = 0.003$). The normed chi-square (χ^2/df) was found to be 2.07, the GFI was .94, NFI was .944, CFI was .97, TLI was .95 while the RMSEA was .073. After assessing the structural fit, the hypothesised relationships in the model were examined. The results, presented in table 3, show that all the seven hypothesised relationships were supported.

Table 3: Hypothesis testing – Direct effect

Path	Regression weights			
	Standardised Regression Coefficient	SE	p	Conclusion
Attitude <--- Utilitarian value	.289	.091	.004	H1: Supported
Attitude <--- Hedonic value	.370	.091	.000	H2: Supported
Intention to revisit <--- Utilitarian value	.234	.100	.024	H3: Supported
Intention to revisit <--- Hedonic value	.288	.102	.005	H4: Supported
Intention to revisit <--- Attitude	.266	.080	.000	H5: Supported

Examining Mediation Effect

According to Baron and Kenny (1986) four conditions need to be satisfied for mediation effect to be accepted. These include firstly the fact that the independent variable needs to be related to the dependent variable, secondly, the independent variable needs to relate to the mediator variable, thirdly, the mediator needs to relate to the dependent variable. The correlation results in table 2 shows that these conditions were met as both utilitarian value and hedonic value were found to be significantly related to intention to revisit store as well as attitude towards store. Attitude towards store was also found to be significantly related to intention to revisit store. The fourth condition entails comparing the results of the direct effect with and without the mediator. According to Baron and Kenny (1986) full mediation is evidenced by the relationship between independent and dependent variable becoming insignificant in the presence of a mediator variable. They also note that partial mediation is evidenced by the relationship between independent and dependent variable getting smaller as a result of having a mediator variable. The results, presented in table 4 show that attitude towards store is a partial mediator of the relationship between utilitarian value as well as hedonic value and intentions to revisit store. Hypotheses 6 and 7 are thus accepted.

Table 4: Hypothesis testing Mediation Effect

Relationship	Direct effect without mediator	Direct effect with mediator	Conclusion
H6: Utilitarian value ---Attitude---Revisit	.308 (.004)	.234 (.024)	Partial mediation
H7: Hedonic value ---Attitude---Revisit	.378 (.000)	.288 (.005)	Partial mediation

DISCUSSION AND IMPLICATIONS

The findings in this study support the notion that customers are often driven by different motives when they go shopping. Some customers enjoy shopping for its own sake while others link shopping heavily to product acquisition. Customers who focus more on product acquisition associate shopping value more with the ease with which they are able to acquire the products they need. Online retailers need to realise that their customers are likely to be mixed in terms of shopping values sought. They thus need to ensure that they are able to provide services that are of value to both utilitarian and hedonic shoppers. The findings point to the positive influence that provision of utilitarian as well as hedonic value by online retailers have on both customers' attitude towards stores and intention to revisit stores. Online store managers need to realise that provision of one set of value does not mean that the other set of values cannot be provided at the same time. This is evidenced by the findings in the study showing significant correlation between perceived utilitarian and hedonic value that retail stores provide.

The need for ease in product acquisition associated with utilitarian shopping orientation entails the need for online retailers to take measures aimed at among other things ensuring that it is easy for customers to search for products on their sites. The customer in this case is interested in fast service and online retailers need to also find ways of ensuring that they are able to serve the customer as quickly as possible. A number of factors can be looked at to help facilitate ease of search as well as ensure fast customer service. For example, managers can consider retail site design issues. The way in which the online store is designed including how products are categorised can have an impact on perceived ease of search. In general, detailed categorisation of products can help improve ease of search. For example, instead of having one big category on women's clothing a retailer can design the store so as to have sub categories within each big category such as dresses, skirts, blouses, women's shoes, accessories etc. for the women's clothing category. Retail managers need to also pay attention to issues of retail site responsiveness. One of the issues of concern here is how fast the pages load on the web site. How quickly can the customer move from one page to another? Since a utilitarian shopper sees value in fast service, web pages that take long to load are likely to be dissatisfying.

Provision of hedonic value entails the need for retail online managers to look for ways of appealing to the emotional state of customers. A hedonic customer wants to spend much time in the shop moving from one site to the other. Such a customer just like a utilitarian shopper is likely to appreciate a retail site with fast loading pages as this will make it easy for a customer interested in exploring a site extensively to be able to easily do so. Other ways in which online customers can make online shopping interesting and enjoyable to hedonic shoppers is by paying attention to product displays. Offline retailers are known to spend a lot of time planning store displays so as to ensure that they are stimulating to senses. Using colour coordination as well as paying attention to quality of product pictures loaded on their sites, online retailers can effectively appeal to the emotional side of shopping. In general online retailer managers need to make sure that product displays are appealing and the online store décor is appealing. It is important to note that while online shopping is commonly associated with utilitarian benefits, the findings in this study show that hedonic value had a stronger influence on both attitude towards online stores and intention to revisit than utilitarian value had. The findings show that online shoppers do not only shop because of the utilitarian value but that they also look for hedonic value. Retailers who provide this value to their customers can positively influence attitude towards their store as well as intention to revisit just as is the case with provision of utilitarian value.

CONCLUSION

Online retailing is on the increase in most parts of the world including South Africa. As more and more retail outlets open online and competition grows, the success of retailers will largely depend on their ability to maximise the value that customers are able to derive from their shopping experience at their respective stores. While sources of customer value may be many and varied, the findings in this study show the importance of value derived from understanding reasons why customers shop i.e. shopping motives. A good understanding of shopping motives in particular the ability to understand utilitarian as well as hedonic shopping motives is important as it can enable a retailer to start looking for ways to create customer value by appealing to such motives. From the findings in this study it can be concluded that levels of perceived utilitarian and hedonic value have significant influence on attitude

towards online stores and on customers' intentions to revisit specific online stores. The results also point to the importance of attitude towards online stores as it mediates, though partially, the influence of both utilitarian and hedonic value on intention to revisit.

While the study makes significant contribution to understanding the influence of shopping motives and value derived on customers' attitude and behavioural intentions, it is not without limitations. The fact that the study is based on a sample drawn Gauteng which is a limited geographical area in South Africa. The findings are thus not generalisable to the wider South African online shoppers' population. Another limitation is to do with the fact that the study examined online shoppers in general. The result may thus not uncover difference in levels of perceived value associated with online stores dealing in different product categories. Future studies can take these limitations into consideration by replicating the study in other areas as well as by focusing on online stores dealing with specific product categories.

REFERENCES

- Abdul-Muhmin, A. (2010). Repeat purchase intentions in online shopping: the role of satisfaction, attitude, and online retailers' performance. *Journal of International Consumer Marketing*, 23(1): 5-20.
- Ajzen, I. (1991). The theory of planned behavior. *Organizational Behavior and Human Decision Processes*, 50(2): 179-211.
- Babin, B., Darden, W., & Griffin, M. (1994). Work and/or fun: measuring hedonic and utilitarian shopping value. *Journal of Consumer Research*, 20(4): 644-656.
- Baron, R., & Kenny, D. (1986). The moderator-mediator variable distinction in social psychological research: conceptual, strategic, and statistical considerations. *Journal of Personality and Social Psychology*, 51(6): 1173-82.
- Berry, L., Seiders, K., & Grewal, D. (2002). Understanding service convenience. *Journal of marketing*, 66(3), 1-17.
- Büttner, O., Florack, A., & Göritz, A. (2013). Shopping orientation as a stable consumer disposition and its influence on consumers' evaluations of retailer communication. http://homepage.univie.ac.at/oliver.buettner/EJM_Shopping_Orientations_manuscript.pdf. (Retrieved 23 March 2014).
- Chen, Q., & Wells, W. (1999). Attitude toward the site. *Journal of Advertising Research*, 39(5): 27-38.
- Chiu, C., Wang, E., Fang, Y., & Huang, H. (2014). Understanding customers' repeat purchase intentions in B2C e-commerce: the roles of utilitarian value, hedonic value and perceived risk. *Information Systems Journal*, 24(1): 85-114.
- Dawson, S., Bloch, P., & Ridgway, N. (1990). Shopping motives, emotional states, and retail outcomes. *Journal of Retailing*, 66(4): 408-427.
- Gounaris, S., Dimitriadis, S., & Stathakopoulos, V. (2010). An examination of the effects of service quality and satisfaction on customers' behavioral intentions in e-shopping. *Journal of Services Marketing*, 24(2): 142-156.
- Hair, J., Black, W., Babin, B., & Anderson, R. (2010). *Multivariate data analysis: A global perspective*. New Jersey: Pearson Education.
- Hirschman, E. (1984). Experience seeking: a subjectivist perspective of consumption. *Journal of Business Research*, 12(1): 115-136.

- Hirschman, E., & Holbrook, M. (1982). Hedonic consumption: Emerging concepts, methods and propositions. *Journal of Marketing*, 46(3): 92-101.
- Jiang, L., Yang, Z., & Jun, M. (2013). Measuring consumer perceptions of online shopping convenience. *Journal of Service Management*, 24(2): 191-214.
- Jones, M., Reynolds, K., & Arnold, M. (2006). Hedonic and utilitarian shopping value: investigating differential effects on retail outcomes. *Journal of Business Research*, 59(9): 974-981.
- Kemp, E. (2013). E-tail emotion regulation: examining online hedonic product purchases. *International Journal of Retail & Distribution Management*, 41(2): 155-170.
- Kim, S., & Eastin, M. (2011). Hedonic tendencies and the online consumer: an investigation of the online shopping process. *Journal of Internet Commerce*, 10(1): 68-90.
- Kim, Y., Lee, M., & Kim, Y. (2011). A new shopper typology: Utilitarian and hedonic perspectives. *Journal of Global Academy of Marketing*, 21(2): 102-113.
- Nusair, K., & Parsa, H. (2011). Introducing flow theory to explain the interactive online shopping experience in a travel context. *International Journal of Hospitality & Tourism Administration*, 12(1): 1-20.
- Olsen, S., & Skallerud, K. (2011). Retail attributes' differential effects on utilitarian versus hedonic shopping value. *Journal of Consumer Marketing*, 28(7): 532-539.
- Overby, J., & Lee, E. (2006). The effects of utilitarian and hedonic online shopping value on consumer preference and intentions. *Journal of Business Research*, 59(10): 1160-1166.
- Ryu, K., Han, H., & Jang, S. (2010). Relationships among hedonic and utilitarian values, satisfaction and behavioral intentions in the fast-casual restaurant industry. *International Journal of Contemporary Hospitality Management*, 22(3): 416-432.
- Sarkar, A. (2011). Impact of utilitarian and hedonic shopping values on individual's perceived benefits and risks in online shopping. *International Management Review*, 7(1): 58-65.
- Tontini, G. (2016). Identifying opportunities for improvement in online shopping sites. *Journal of Retailing and Consumer Services*, 31, 228-238.
- Zeithaml, V., Berry, L., & Parasuraman, A. (1996). The behavioural consequences of service quality. *Journal of Marketing*, 60(2): 31-46.

BRAND PERSONALITY SCALE DEVELOPMENT – A LITERATURE ANALYSIS

Re-an Müller

North-West University (Vaal Triangle Campus), South Africa

ABSTRACT

The contemporary market place is saturated with brands that compete for consumers' attention, making it more challenging than ever before for marketers to differentiate their brands from those of their competitors. Creating a particular personality for a brand is well recognised as a marketing strategy to affect such a differentiation and create a strong brand image and, ultimately, higher brand preference and greater brand loyalty. Consequently, creating the need for tools to measure consumer perceptions of a brand's personality. This paper analyses the development of several brand personality trait scales to determine common practice during this tedious process. The findings indicate that the process consists of four basic steps namely: identifying traits, reducing the list of traits, analysing the dimensions and determining the reliability and validity of the scale. This paper will guide researchers who are planning on developing and validating a brand personality trait scale.

Keywords: Brand personality, brand personality trait scale, scale development and validation, branding.

INTRODUCTION

Aaker (1997) defines brand personality as “the set of human characteristics associated with a brand” (p. 347). Various researchers (Sung & Tinkham, 2005; Bosnjak *et al.*, 2007; Valette-Florence *et al.*, 2011; Tsiotsou, 2012; Matzler *et al.*, 2016) agree that this is the most widely accepted definition of brand personality. Freling and Forbes (2005) analysed the brand personality definitions of various authors (Plummer, 1985; Batra *et al.*, 1993; Goodyear, 1993; Blackston, 1995; Aaker, 1997) and concluded that all of these definitions are similar and refer to some form of human descriptors to describe a brand. Brands have personalities, just like humans, that set them apart from competing brands (Jones & Bonevac, 2013; Freling & Forbes, 2005). Brand personality traits are often used to communicate the brand's position within the market (Van Rekom *et al.*, 2006). Brands function as entities with their own personality traits. There are several examples of strong brand personalities in the market. Absolut Vodka is personified as a hip, cool, contemporary 25-year-old, whereas Stolli's is likened to a more intellectual and conservative older man (Aaker, 1997). The Honda Civic may be described as a rugby player in a dinner suit (Blythe, 2007). Apple is considered young, while IBM is perceived as older (Aaker, 1997). Chanel is perceived as a classic, elegant and sophisticated brand (Hwang & Kandampully, 2012), while Victoria's Secret is viewed as exciting and Nike as rugged (Kim & Hall, 2014).

Brand personality is thought to influence consumers positively in a number of different ways. It can increase consumers' preference for and usage of a brand, resulting in stronger emotional ties and loyalty towards a brand (Ramaseshan & Tsao, 2007). It affects consumers' feelings, perceptions and attitudes (Freling & Forbes, 2005). As such, brand personality also appeals to consumers and aids in building stronger relationships between an organisation and its target market(s) (Chang & Lin, 2010). Brand personality is so influential that it may even influence the overall reputation of the organisation amongst consumers (Veloutsou & Taylor, 2012). Brand personality may be described as the soul of a brand, which originates from the brand's characteristics and from marketing communications (Ramaeseshan & Tsao, 2007). These brand personality traits aid in creating emotional fulfilment for consumers and this, in turn, may lead to brand loyalty (Freling & Forbes, 2005). Aaker (1996) identifies brand personality as one of the causal components of brand equity. Masterson and Pickton (2010) point out that brand personality is at the core of an organisation, influencing brand identity, brand image and eventually brand equity. Ahmad and Thyagaraj (2014) describe brand personality and brand equity as interrelated branding

concepts that influence a brand management strategy. As a result, organisations need to assess the perceived brand personality of their brand amongst consumers to guide their future marketing strategy.

MEASUREMENT OF BRAND PERSONALITY

Organisations and marketing researchers have realised the importance of brand personality and have started to develop tools to measure consumer perceptions thereof. Several authors (Aaker, 1997; Ferrandi *et al.*, 1999; Aaker *et al.*, 2001; Smit *et al.*, 2002; Sung & Tinkham, 2005; Bosnjak *et al.*, 2007; Geuens *et al.*, 2009; Braunstein & Ross, 2010; Muniz & Marchetti, 2012) have developed brand personality trait scales.

Aaker (1997) was the first researcher to develop a standardised brand personality trait scale. The scale was developed in the USA and was not product- or category-specific. This general brand personality trait scale was validated across various product categories. The scale comprises five dimensions (sincerity, excitement, competence, sophistication and ruggedness) and 15 facets, which are subdivided into 42 traits. This scale is still regarded as the most prominent brand personality measurement tool and is used by a significant number of researchers. The scale has been cited in more than 7300 research papers (Google Scholar, (2017) and has served as the starting point for the development of several of the other brand personality trait scales discussed in this study.

Ferrandi *et al.* (1999) were of the first to try and reproduce Aaker's (1997) scale in another country. The study aimed to implement Aaker's scale in a French setting using eight different brands in four product categories (clothes, coffee, cake and beer). The scale resulted in a reduced version of Aaker's (1997) scale, with 33 traits subdivided into five factors (sincerity, excitement, sophistication, ruggedness and user-friendliness). The similarities with Aaker's (1997) scale are apparent, with the only difference being the user-friendliness factor that replaces Aaker's competence factor.

Aaker *et al.* (2001) aimed to develop a brand personality trait scale in Japan and Spain, while comparing it to Aaker's (1997) original American brand personality trait scale. Both the Japanese and Spanish scales were developed for various product categories and comprise five factors. The Japanese brand personality trait scale consists of 36 traits and 12 facets subdivided into five factors (excitement, competence, peacefulness, sincerity and sophistication). Once again the similarities between this scale and Aaker's (1997) original scale are apparent, with the only difference being the peacefulness factor that replaces Aaker's ruggedness factor. The Spanish brand personality trait scale consists of 33 traits and 11 facets subdivided into five factors (excitement, sincerity, sophistication, peacefulness and passion). There are only three factors (excitement, sincerity and sophistication) that are in line with Aaker's (1997) original scale, and two new factors (peacefulness and passion) added to the Spanish brand personality trait scale.

Smith *et al.* (2002) aimed to replicate Aaker's (1997) brand personality trait scale in the Netherlands. The scale was developed using brands from 11 product categories (cars, beer, shampoo, tele-services, beverages, cigarettes, rolling tobacco, banks, mail carriers, insurance organisations and grocery stores). The Dutch brand personality trait scale consists of 38 traits subdivided into six factors (competence, excitement, gentle, distinguishing, ruggedness and annoying). Of these factors, three, namely competence, excitement and ruggedness, are in accordance with Aaker's (1997) scale. In addition, gentle, distinguishing and annoying are three more factors included in this scale. Interestingly, Smit *et al.* (2002) were the first of these researchers to include a negative factor (annoying).

Sung and Tinkham (2005) conducted a cross-cultural research study to compare brand personality perceptions of various brands in diverse product categories between Korea and America. The study revealed eight factors in each country. Of the eight factors, six (likeableness, trendiness, competence, sophistication, traditionalism and ruggedness) were present in both the American and the Korean results. Furthermore, four of these factors (competence, sophistication, traditionalism/sincerity and ruggedness) share similarities with Aaker's (1997) original scale. Sung and Tinkham's (2005) American scale had an additional two factors, namely white collar and androgyny while the Korean scale also had an additional two factors, namely passive-likeableness and ascendancy.

Bosnjak *et al.* (2007) aimed to develop a brand personality trait scale that would be indigenous to Germany, utilising a wide variety of brands from various product categories. The German brand personality trait scale consists

of four distinct factors (drive, conscientiousness, superficiality and emotion). The drive factor comprises two elements, namely excitement (positive differential effect on drive) and boredom (negative differential effect on drive). This scale also identifies a negative factor (superficiality). There are some similarities between these factors and Aaker's (1997) dimensions, namely excitement, competence and sincerity.

Geuens *et al.* (2009) aimed to develop a scale that would be compatible for any product category across cultures. Consequently, the authors made use of 20 different product categories and validated the scale in various European countries as well as the USA. The scale comprises 12 traits subdivided into five factors, namely responsibility, activity, aggressiveness, simplicity and emotionality. There are once again some definite similarities between this scale's factors and Aaker's (1997) dimensions of sincerity/competence (responsibility and simplicity), excitement (activity), ruggedness (aggressiveness) and sophistication (emotionality).

Braunstein and Ross (2010) developed a brand personality trait scale to be used specifically for sport teams. The scale consists of 40 items divided into six factors, namely successfulness, sophistication, sincerity, ruggedness, community-driven and classic. Of these, four factors, namely successfulness (competence), sophistication, sincerity and ruggedness are in accordance with Aaker's (1997) original scale. Community-driven and classic are two more factors included in this scale.

Muniz and Marchetti (2012) aimed to replicate Aaker's (1997) brand personality trait scale in Brazil. The scale was developed using brands from 12 product categories. The Brazilian brand personality trait scale consists of 28 traits subdivided into five factors (credibility, joy, audacity, sophistication and sensitivity). Of these, four factors (credibility, joy, audacity and sophistication) are in agreement with Aaker's (1997) original scale. In addition, sensitivity is included in this scale.

All of the above mentioned scales followed a very specific process during the development and validation of the brand personality trait scales. The subsequent section analyses this process utilised by each of the researchers.

DEVELOPMENT OF A BRAND PERSONALITY SCALE

After analysing the various brand personality studies, it is evident that the following steps are utilised when developing a brand personality trait scale, namely, generate an initial list of personality traits, reduce the initial list to a more manageable number of traits, assess the brand personality dimensions, and test the reliability / generalisation of the developed scale.

Personality trait generation

The personality traits in each of the studies were generated using a review of current literature or a combination of current literature and exploratory research. Aaker (1997) obtained an initial list of traits from three sources. First, personality scales were obtained from the field of psychology and based on the Big Five personality constructs. Secondly, existing personality scales used by marketers were obtained. Finally, a qualitative approach using the free-association method whereby 16 respondents were asked to write down the personality traits that come to mind when thinking of certain brands was employed.

Several of the researchers (Ferrandi *et al.*, 1999; Smit *et al.*, 2002; Braunstein & Ross, 2010) only utilised the literature in terms of already established scales from psychology and marketing to compile the initial list of personality traits. Ferrandi *et al.* (1999) used the brand personality trait scale developed by Aaker (1997) to compile a list of 42 traits, which were then translated into French. Smit *et al.* (2002) used a Dutch translation of Aaker's scale combined with an established Dutch personality scale to compile an initial list of 102 traits. Braunstein and Ross (2010) compiled a list of 84 traits utilising already developed brand personality traits scales (Aaker, 1997; Braunstein & Zhang, 2005).

Some of researchers (Aaker *et al.*, 2001; Sung & Tinkham, 2005; Bosnjak *et al.*, 2007; Geuens *et al.*, 2009; Muniz & Marchetti, 2012) used a combination of current literature and exploratory research to generate an initial list of personality traits. Aaker *et al.* (2001) obtained an initial list of 253 traits (Japan) and 266 traits (Spain) from three sources. First, a free-association task was used where respondents (46 from Japan and 36 from Spain) were asked to

write down the personality traits that come to mind when thinking of certain brands. These items were then added to items from existing personality scales used by marketers in each of these countries and items from a personality scale drawn from psychology, based on the Big Five personality constructs, which was similar to Aaker's (1997) approach.

Sung and Tinkham (2005) compiled an initial list of 91 personality traits by using a free-association task (29 respondents from Korea and 28 from the USA) and added the 42 traits from Aaker's (1997) brand personality scale. Geuens *et al.* (2009) used an initial list of 244 traits, which were collected from three sources. These sources included Aaker's (1997) brand personality scale, various personality scales based on the Big Five personality constructs and focus groups where respondents were asked to describe certain brands as if they were humans. Muniz and Marchetti (2012) compiled an initial list of 174 traits from the literature (Aaker, 1997; Aaker *et al.*, 2001), in-depth interviews with researchers and professionals, as well as traits from dictionaries as researched by the authors. This trait generation step often led to a large number of traits that had to be reduced to a more manageable number.

Personality trait reduction

The personality traits generated in each of the studies, except in Ferrandi *et al.* (1999), Smit *et al.* (2002) and Braunstein and Ross (2010), were reduced in number by means of a survey and/or elimination by researchers/experts. Aaker (1997) reduced the initial list of 309 to 114 by means of a survey, whereby 25 respondents had to rate how descriptive the traits were of brands in general on a seven-point Likert scale. All traits with a mean value below six were discarded to ensure that only the most relevant traits remained. Aaker *et al.* (2001) eliminated redundant and ambiguous traits of the initial list of traits and presented the remaining traits (167 = Japan, 171 = Spain) to respondents (140 = Japan, 75 = Spain), who were asked to rate how descriptive the traits were of the most salient brands in ten product categories on a five-point Likert scale. All traits with a mean value below four were discarded to ensure that only the most relevant traits remained.

Sung and Tinkham (2005) reduced their list of 109 traits to 80 traits by removing negative, irrelevant and redundant traits. Bosnjak *et al.* (2007) reduced their initial list of traits to 108 traits by eliminating redundant and ambiguous traits, as well as traits that were not applicable and relevant to brands. The authors reduced the list further to 84 by means of a focus group, whereby the respondents judged the traits based on semantic clarity, applicability and uniqueness. Geuens *et al.* (2009) reduced their list to 40 traits by means of eliminating redundant and ambiguous traits using expert opinions (marketing professionals and marketing researchers). The experts were asked to delete traits that they viewed to be inappropriate for brands. The experts also had to indicate which traits were the most and least appropriate for brand personality, which resulted in a final list of 40 traits. Muniz and Marchetti (2012) reduced their initial list of 174 traits to 87 traits by means of a survey, whereby 24 experienced marketing researchers and professionals were asked to rate on a seven-point Likert scale how descriptive the traits were of brands in general. All traits with a mean value below five were discarded to ensure that only the most relevant traits remained. Once the traits had been reduced, the next step was to do empirical research to construct the proposed dimensions for the brand personality scales.

Assessing the brand personality dimensions

In order to assess the brand personality dimensions, the researchers (Aaker, 1997; Ferrandi *et al.*, 1999; Aaker *et al.*, 2001; Smit *et al.*, 2002; Sung & Tinkham, 2005; Bosnjak *et al.*, 2007; Geuens *et al.*, 2009; Braunstein & Ross, 2010; Muniz & Marchetti, 2012) employed exploratory factor analysis (EFA).

Aaker (1997, p. 30), Aaker *et al.* (2001), Smit *et al.* (2002), Bosnjak *et al.* (2007), Geuens *et al.* (2009) and Muniz and Marchetti (2012) made use of a principal components analysis with the varimax rotation. Ferrandi *et al.* (1999) mention that a principal components analysis was performed but do not specify which factor rotation method was used. Sung and Tinkham (2005) used a principal component analysis with the promax rotation. Braunstein and Ross (2010) utilised a maximum likelihood extraction with the varimax rotation.

Aaker (1997) used a combination of eigenvalues above 1 as well as an analysis of the scree plot to specify the five factors to be extracted. These five factors explained 92 percent of the total variance. Items with factor

loadings below 0.4 were discarded, resulting in the 42-item five-factor model. Ferrandi *et al.* (1999) used priori criteria based on Aaker's (1997) scale to specify five factors to be extracted, which explained 60.44 percent of the total variance. Variables with low communalities were discarded, resulting in a 33-item five-factor model.

Aaker *et al.* (2001) utilised an analysis of the shape of the scree plot to specify five factors for both their studies in Japan and Spain. Neither of these two studies indicated the total variance explained. Both studies conducted an EFA for the respective factors identified to determine facets for each factor (Japan = 12 facets, Spain = 11 facets). The top three traits for each facet were retained, resulting in a 36-item five-factor model for Japan and a 33-item five-factor model for Spain.

Smit *et al.* (2002) utilised an analysis of the scree plot to identify seven factors. Each of the factors was then factor-analysed to determine the facets of each. Only the traits with factor loadings above 0.6 and with high item-to-total correlations within each facet were retained. One of the factors was discarded during this analysis based on a lack of items explaining the factor and resulting in a 38-item six-factor model.

Sung and Tinkham (2005) used a combination of eigenvalues above 1 as well as an analysis of the scree plot to specify eight factors to be extracted, which explained 61.5 percent of the total variance. The researchers did not discard any of the traits as the main objective of the study was to determine cross-cultural differences between Korea and the USA. Sung and Tinkham (2005) concluded that six factors were universal between the two countries and each country had an additional two culture-specific factors.

Bosnjak *et al.* (2007) used a combination of eigenvalues above 1 and an analysis of the scree plot to specify four factors to be extracted, which explained 47.9 percent of the total variance. Only 20 variables with high factor loadings as well as high item-to-total correlations were kept from the initial list of 84 personality traits. This resulted in a 20-item, four-factor model. Geuens *et al.* (2009) used eigenvalues above 1 to specify five factors to be extracted, explaining 59.63 percent of the total variance. Variables with a factor loading below 0.6 were discarded, together with any variables cross-loading with a factor loading above 0.35. This resulted in 18 remaining traits of the initial 40 traits. During the CFA, a further six traits were discarded based on modification indices to obtain a satisfactory model fit, resulting in a 12-item five-factor model.

Muniz and Marchetti (2012) made use of a split-half technique to conduct two EFAs. Eigenvalues above 1 were used to specify five factors in the first sample and four factors in the second sample, explaining 52.52 percent and 50.74 percent of the variance, respectively. After analysing the two-factor structures, the researchers decided to opt for the five-factor structure, which was more significant and interpretable. Traits with a factor loading below 0.41 as well as redundant traits and traits that cross-loaded were discarded, resulting in a 28-item five-factor model.

Assessing the reliability and validity of the developed scale

Along with the EFA, most of the researchers (Aaker, 1997; Ferrandi *et al.*, 1999; Aaker *et al.*, 2001; Bosnjak *et al.*, 2007; Geuens *et al.*, 2009; Braunstein & Ross, 2010; Muniz & Marchetti, 2012) also made use of CFA by means of SEM in order to assess the reliability and validity of the developed scales. They utilised several model fit indices, including the chi-square (X^2), the goodness-of-fit index (GFI), the adjusted-goodness-of-fit index (AGFI), the comparative fit index (CFI), the normed fit index (NFI), the incremental fit index (IFI), the relative fit index (RFI), the centrality index (CI), the root mean square residual (RMSR), the root mean square error of approximation (RMSEA) and the Tucker Lewis index (TLI). Table 1 lists the model fit indices used by each of these researchers.

In addition to model fit indices, several of the researchers (Geuens *et al.*, 2009; Braunstein & Ross, 2010; Muniz & Marchetti, 2012) also assessed the composite reliability. Furthermore, Sung and Tinkham (2005), Geuens *et al.* (2009), Braunstein and Ross (2010), and Muniz and Marchetti, (2012) assessed the convergent and discriminant validity of their respective scales.

Table 1: Model fit indices of various brand personality trait scales

Author(s)	Model fit indices
Aaker (1997)	CFI, GFI, AGFI, RMSR, Chi-Square
Ferrandi <i>et al.</i> (1999)	RMSEA, GFI, AGFI
Aaker <i>et al.</i> (2001)	CFI, GFI,
Bosnjak <i>et al.</i> (2007)	Chi-Square, CFI, RMSEA, CI
Geuens <i>et al.</i> (2009)	Chi-square, TLI, CFI, RMSEA
Braunstein and Ross (2010)	RMSEA, TLI, CFI
Muniz and Marchetti (2012)	Chi-Square, GFI, NFI, RFI, IFI, TLI, CFI, RMSEA

Aaker (1997) and Geuens *et al.* (2009) also utilised a test-retest reliability test to ensure the reliability of the scale. Aaker (1996) used a random subset of her original sample to conduct the test-retest, while Geuens *et al.* (2009) conducted the same test again one year later to ensure reliability. All the authors utilised Cronbach's Alpha to confirm the internal-consistency reliability of the scales.

The studies analysed developed brand personality scales in Europe (France, Spain, the Netherlands, Germany and Belgium), the East (Japan and Korea), Brazil and the USA. A summary of the findings of these brand personality-trait-scale development processes using the method proposed by Das *et al.* (2012) is provided in Appendix 1.

CONCLUSION AND MANAGERIAL IMPLICATIONS

Brand personality is a concept that has been around for several decades. It is an important differential factor that positively influences consumer behaviour. A wide variety of scales have been developed to measure this marketing phenomenon. This paper analysed the process of brand personality scale development and concluded that it consists of four steps. The steps include identifying traits, reducing the list of traits, analysing the dimensions and determining the reliability and validity of the scale. This paper highlights the various methods used by several authors to approach each of these steps. The findings presented in this paper is in line with the findings of Das *et al.* (2012). However, this study evaluated a wider variety of scales and analysed each of the steps in more detail.

This analysis provides comprehensive guidelines for the development and validation of a brand personality trait scale. This information will be of value to organisations or marketing researchers who plan on developing and validating a new brand personality trait scale. Consideration of each of the various approaches is recommended to derive a unique approach to the development of a new brand personality trait scale. This paper highlights the fact that brand personality scales are country specific and that the development of a country-specific scale is pivotal.

Despite certain limitations, I feel that the findings presented in this paper cover the core aspects regarding the development and validation of a brand personality trait scale. The study analysed the most prominent brand personality trait scales between 1997 and 2012. Future research could consider analysing newly developed brand personality trait scales to determine if the same four-step process was followed. Furthermore, this paper studied the development of brand personality trait scales globally while it is evident that scales are country specific. Future research could consider analysing and comparing brand personality trait scales between different countries. Lastly, this paper studied brand personality trait scales irrespective of product category. Future research should consider examining the differences amongst brand personality trait scales based on specific product categories.

APPENDIX 1: SUMMARY OF BRAND PERSONALITY STUDIES

	Aaker (1997)	Ferrandi <i>et al.</i> (1999)	Aaker <i>et al.</i> (2001)	Smit <i>et al.</i> (2002)
Country	USA	France	Japan and Spain	Netherlands
Initial number of items	309	44	253 (Japan) 266 (Spain)	102
Sources of items	Personality scale from psychology, personality scales used by marketers and a free-association task (qualitative).	Literature	Free-association task (qualitative), personality scales used by marketers and personality scale from psychology.	Literature
Item reduction process	Survey with consumers	Student survey	Elimination by researchers. Consumer survey.	Consumer survey
Sample size for reduction	25	82	140 (Japan) 75 (Spain)	4533
Reduced items	114	33	100 (Japan) 77 (Spain)	38
Sample size for dimension assessment	631	83	1495 (Japan) 692 (Spain)	4533
Sample size for generalisation / reliability	Evaluation	N/A	60 (Japan) 58 (Spain)	Evaluation
Number of brands used in the dimension assessment study	37	8	25 (Japan) 25 (Spain)	20
Number of brands used for generalisation / reliability	20	N/A	20 (Japan) 20 (Spain)	93
Number of traits and constructs in final scale	42-item five-factor model	33-item five-factor model	37-item five-factor model (Japan) 34-item five-factor model (Spain)	38-item five-factor model
Survey method	Household	Student survey	Customer survey	Online
Sampling technique	Convenience	Convenience	Convenience	Convenience
Factor analysis	Exploratory and Confirmatory	Exploratory and confirmatory	Exploratory and confirmatory	Exploratory and confirmatory

APPENDIX 1: SUMMARY OF BRAND PERSONALITY STUDIES (CONTINUED...)

	Sung and Tinkham (2005)	Bosnjak <i>et al.</i> (2007)	Geuens <i>et al.</i> (2009)	Braunstein and Ross (2010)	Muniz and Marchetti (2012)
Country	USA and Korea	Germany	Belgium	USA	Brazil
Initial number of items	109	345	244	84	174
Sources of items	Literature and individual interview	Literature, free-association task and focus group interview	Literature and focus group interviews	Literature	Literature, individual interviews and dictionary search by researcher
Item reduction process	Elimination by researchers	Elimination by researchers. Focus group.	Elimination by researchers. Expert's opinion.	Student survey	Survey (professionals and academics)
Sample size for reduction	N/A	5	28	N/A	24
Reduced items	80	84	40	N/A	87
Sample size for dimension assessment	320 (US) 337 (Korea)	131	1235	225	1302
Sample size for generalisation / reliability / psychometric	N/A	184	12 789	224	1180
Number of brands used in the dimension assessment study	13	13	20	N/A	24
Number of brands used for generalisation / reliability	N/A	4	193	N/A	24
Number of traits and constructs in final scale	70-item six-factor model (USA) 60-item six-factor model (Korea)	20-item four-factor model	12-item five-factor model	40-item six-factor model	28-item five-factor model
Survey method	Student survey	Online	Online	Student survey	Online
Sampling technique	Convenience	Convenience	Convenience	Convenience	Convenience
Factor analysis	Exploratory	Exploratory and confirmatory	Exploratory and confirmatory	Exploratory and confirmatory	Exploratory and confirmatory

Source: Adapted from Das et al., (2012, p. 49–50).

REFERENCES

- Aaker, J.L. (1997). Dimensions of Brand Personality. *Journal of Market research*, 34(3):347-356.
- Aaker, J.L., Benet-Martínez, V. & Garolera, J. (2001). Consumption symbols as carriers of culture: A study of Japanese and Spanish brand personality constructs. *Journal of Personality & Social Psychology*, 81(3):492-508.
- Ahmad, A., & Thyagaraj, K.S. (2014). Brand Personality and Brand Equity Research: Past Developments and Future Directions. *IUP Journal of Brand Management*, 11(3):19-56.
- Batra, R., Lehmann, D.R. & Singh D. (1993). The Brand Personality Component of Brand Goodwill; Some Antecedents and Consequences. (In Aaker, D.A. & A. Biel eds. *Brand Equity and Advertising*, 83-96).
- Blackston, M. (1995). The qualitative dimension of brand equity. *Journal of Advertising Research*, 35(4):RC2-RC7.
- Blythe, J. (2007). Advertising creatives and brand personality: A grounded theory perspective. *Journal of Brand Management*, 14(4):284-294, Apr.
- Bosnjak, M., Bochmann, V. & Hufschmidt, T. (2007). Dimensions of Brand Personality Attributions: A Person-Centric Approach in the German Cultural Context. *Social Behavior and Personality: an international Journal*, 35(3):303-316.
- Braunstein, J.R. & Ross, S.D. (2010). Brand personality in sport: Dimension analysis and general scale development. *Sport Marketing Quarterly*, 19(1):8-16.
- Chang, W.L. & Lin, H.L. (2010). The impact of color traits on corporate branding. *African Journal of Business Management*, 4(15):3344-3355.
- Das, G., Guin, K.K. & Datta, B. (2012). Developing Brand Personality Scales: A literature review). *The IUP Journal of Brand Management*, 9(2):45-63.
- Ferrandi, J.M., Falcy, S.F., Kreziak, D. & Valette-Florence, P. (1999). Aaker's brand personality scale: a replication and a double methodological validation in a French setting. (In Proceedings of the third international research seminar on marketing communications and consumer behavior, La Londe les Maures, France: IAE d'Aix-en-Provence, 240-259).
- Freling, T.H. & Forbes, L.P. (2005). An examination of brand personality through methodological triangulation. *Journal of Brand Management*, 13(2):148-162, Nov.
- Geuens, M., Weijters, B. & De Wulf, K. (2009). A new measure of brand personality. *International Journal of Research in Marketing*, 26(2):97-107.
- Goodyear, M. (1993). Reviewing the concept of brands and branding. *Marketing and Research Today*, 21(2):75-79.
- Google Scholar. (2017). Citations: Dimensions of brand personality.
https://scholar.google.co.za/scholar?cites=18327442382989909733&as_sdt=2005&scioldt=0,5&hl=en Date of access: 28 April 2017.
- Hwang, J. & Kandampully, J. (2012). The role of emotional aspects in younger consumer-brand relationships. *Journal of Product & Brand Management*, 21(2):98-108.
- Jones, C. & Bonevac, D. (2013). An evolved definition of the term 'brand': Why branding has a branding problem. *Journal of Brand Strategy*, 2(2):112-120.

- Kim, H.S., & Hall, M.L. (2014). Fashion Brand Personality and Advertisement Response: Incorporating a Symbolic Interactionist Perspective. *Fashion Branding and Consumer Behaviors* (pp. 29-45). Springer New York.
- Masterson, R. & Pickton, D. (2010). *Marketing: an introduction*. SAGE Publications.
- Matzler, K., Strobl, A., Stokburger-Sauer, N., Bobovnick, A. & Bauer, F. (2016). Brand personality and culture: The role of cultural differences on the impact of brand personality perceptions on tourists' visit intentions. *Tourism Management*, 52:507-520.
- Mulyanegara, R.C., Tsarenko, Y. & Anderson, A. (2009). The big five and brand personality: investigating the impact of consumer personality on preferences towards particular brand personality, *Journal of Brand Management*, 16(4):234-247.
- Muniz, K.M. & Marchetti, R.Z. (2012). Brand personality dimensions in the Brazilian context. *BAR-Brazilian Administration Review*, 9(2):168-188.
- Plummer, J.T. (1985). How personality makes a difference. *Journal of advertising research*, 24(6):27-31.
- Ramaseshan, B. & Tsao, H.Y. (2007). Moderating effects of the brand concept on the relationship between brand personality and perceived quality. *Journal of Brand Management*, 14(6):458-466.
- Smit, E.G., Van den Berge, E. & Franzen, G. (2003). Brands are just like real people. *Branding and Advertising*. Copenhagen Business School Press, Copenhagen, 22-43.
- Sung, Y. & Tinkham, S.F. (2005). Brand personality structures in the United States and Korea: Common and culture-specific factors. *Journal of consumer psychology*, 15(4):334-350.
- Tsiotsou, R. 2012. Developing a scale for measuring the personality of sport teams. *Journal of Services Marketing*, 26(4):238-252.
- Valette-Florence, P., Guizani, H. & Merunka, D. (2011). The impact of brand personality and sales promotions on brand equity. *Journal of Business Research*, 64(1):24-28.
- Van Rekom, J., Jacobs, G., Verlegh, P.W.J. & Podnar, K. (2006). Capturing the essence of a corporate brand personality: A Western brand in Eastern Europe, *Journal of Brand Management*, 14(1/2):114-124.
- Veloutsou, C. & Taylor, C.S. (2012). The role of the brand as a person in business to business brands. *Industrial Marketing Management*, 41(6):898-907.

THE PROMINENCE OF BRANDING THROUGH HISTORY AND ITS RELEVANCE TO MODERN BRANDS: A LITERATURE REVIEW

Re-an Müller

North-West University (Vaal Triangle Campus), South Africa

ABSTRACT

Modern branding can be defined as the core beliefs and values of the organisation regarding all business practices and interactions with consumers. Branding has been part of human existence for several millenniums and has evolved from being a mark of ownership and identification, to being a method of quality assurance, to a bearer of certain symbolic associations and, ultimately essential in creating a trust relationship between organisations and consumers. Brands have become one of the most valuable intangible assets for an organisation. The purpose of this paper is to investigate the significance of branding through history and how it developed to the important business asset it is today.

Keywords: Branding, history of branding, brands, brand equity, marketing.

INTRODUCTION

Defining branding is a controversial issue in marketing (Kapferer, 2012). Each expert has their own views as to what constitutes branding, resulting in numerous definitions for the term (Jahandoost & Bahrani, 2013). These diverse definitions have caught the attention of several authors (De Chernatony & Riley, 1998; Maurya & Mishra, 2012; Jones & Bonevac, 2013), who have attempted to identify the most common themes regarding branding. One widely accepted definition of branding is that it is a mark of distinction that serves as a sign of differentiation between competitors (Aaker, 2009; Van Zyl, 2011; Du Toit & Erdis, 2013). According to the American Marketing Association (Committee on Definitions, 1960), this mark of distinction can be anything from “a name, term, sign, symbol, design, or a combination of these” (p. 8). Jones and Bonevac (2013) assert that this definition reflects the origin of the term ‘branding’ as being a mark of identification. Qu *et al.* (2011) explain ‘identification’ to be the revelation of the source of the product to the consumer. Therefore, the mark of identification (name/logo) identifies the producer and/or the origin of production. However, Aaker (2014) emphasises that branding is much more than a name and logo. A brand communicates a promise to consumers regarding the benefits of consumption, while denoting a set of values in the consumer’s mind (Kapferer, 2012). This set of values refers to everything the consumer considers to be important regarding the brand. Strizhakova *et al.* (2011) suggest that consumers use brand names as a quality assurance method, which influences their brand choice. Quality assurance can be based on the brand’s reputation, which is maintained by means of communication efforts with consumers (Dranove & Jin, 2010). Consumers interact with organisations on various levels and their perception of the brand’s reputation is shaped by these interactions. Chung *et al.* (2013) define a brand as the sum of all experiences from a consumer’s perspective. Middleton (2011) emphasises this by defining a brand as being “the sum total of all things that people think, feel, suspect, imagine, believe, wish and say about a brand” (p. 108). De Chernatony and Riley (1998) argue that a brand can be defined as an image formed in the mind of consumers. This image is the result of how the organisation was presented to consumers. Consequently, an organisation needs to determine what they are going to present to consumers. Moreover, the organisation needs to know how they view themselves. Jones and Bonevac (2013) explored various definitions of branding and concluded that a brand is “the definition of your organisation” (p. 117–118).

Collectively, these various arguments suggest that there are several aspects inherent in the concept of branding. Consequently, branding may be defined as the core beliefs and values of the organisation concerning all

business practices and interactions with consumers. This definition encapsulates the key aspects highlighted by the diverse definitions of branding.

ORIGIN OF BRANDING

“Branding, as a concept, is older than the modern theory” (Herman, 2003, p. 711). For centuries, branding has served to distinguish one producer’s goods from another (Kumar, 2014.) This suggests that branding practices have been around for several millenniums (Moore & Reid, 2008; Eckhardt & Bengtsson, 2010). The modern-day marketing term ‘brand’ was derived from the Old Norse term ‘*brandr*’, meaning to burn (Roper & Parker, 2006). The term referred to the burning of a mark of ownership onto livestock (Khan & Mufti, 2007; Maurya & Mishra, 2012). Cattle were branded to distinguish them from other cattle on markets. Family names were often used as a brand, not only to identify the livestock but also to serve as a quality assurance and guarantee (Sheth & Parvatiyar, 1995). While Dranove and Jin (2010) state that the branding of cattle dates back to 2000 BC, there are indications that branding practices indicating products’ origin of production date back even further.

Wengrow (2008) presents evidence regarding sealing practices as early as 7000 BC in the Mesopotamia region (modern-day Iraq). Eckhardt and Bengtsson (2010) argue that these early seals served as an indication of origin as well as a mark of quality. These early forms of branding were also used as a marking to indicate ownership. Yang *et al.* (2012) suggest that stone seals discovered in the Middle East dating back to 3500 BC indicated ownership. These early forms of branding do have some resemblances to modern branding. Wengrow (2008) analysed an ancient commodity label from a royal tomb in Egypt, which dates back to around 3000 BC. The ancient oil label was compared to a modern wine label to determine similarities. Both labels had an indication of quantity and region of origin, as well as a core message being conveyed (Wengrow, 2008). There are definite similarities between this ancient commodity label and modern-day branding practices. This verifies that branding has indeed been around for thousands of years.

Early forms of branding practices were not limited to only the Middle East region. Greenberg (1951, *cited in* Eckhardt & Bengtsson, 2009) mentions the discovery of stamps on pottery dating back to 2700 BC in China. These seals were used to identify and differentiate products. Yang *et al.* (2012) also refer to some craftsmen seals dating back to 2250 BC – 2000 BC in the Indus Valley (modern-day India). Researchers discovered these craftsmen seals attached to containers, indicating, among other things, the origin of production and even some form of brand imagery (Moore & Reid, 2008). The seals showed all kinds of animals and, in some instances, even labels of gods such as the fertility god label of Shiva (Moore & Reid, 2008). These findings are supported by Singh (1971), who noted that drawings and engravings of animals and plants were discovered on broken pieces of ceramic material and steatite seals in the region of the Indus Valley. Reddi (2009) suggests that these seals were often used as trademarks in stores. One could argue that these brand imageries could be an ancient form of brand personality creation.

There is also evidence of branding during the middle bronze age (2000 BC – 1500 BC) in the region of Shang China (Moore & Reid, 2008). Products in this region were mostly regulated by the king (*wang*) and, therefore, carried a *Zu* family crest marking. These crests informed consumers of the origin of the product and served as quality assurance. Moore and Reid (2008) argue that the *Zu* crests can be regarded as a form of primitive branding.

Some of the earliest evidence of consumer packaging in the form of amphorae (large ceramic containers) could be found throughout the Mediterranean from 1500 BC to AD 500 (Grace, 1979; Twede, 2002). These containers came in various shapes and had different identifying markings and labels, depending on the origin. Some of the containers had very specific markings showcasing the identity of the producer, contents, date of production as well as the price. The main purpose of these container markings was for product identification and differentiation (Holleran, 2012). Twede (2002) reasons that the Greek containers had more personality than the Roman containers. Wine containers from Chios were among these distinctive Greek containers. The Chios wine was the most famous wine in the region and these containers had a distinguishing slender shape, which also appears on Chios coins (Papadopoulos & Paspalas, 1999). Twede (2002) argues that the use of this trademark shape of containers as well as displaying the shape on coins could be tied to modern-day marketing campaigns.

Eckhardt and Bengtsson (2009) name the *White Rabbit* brand (needle manufacturer) as the earliest documented complete brand, dating back to the Song Dynasty (AD 960 – AD 1127) in China. The *White Rabbit* brand logo was

printed on paper in which the needles were packaged. The packaging indicated the name of the producer, details regarding the production, usability and discount availability. The *White Rabbit* was an important symbol for the local people. The brand originated from a well-known Chinese legend about Chang E. Chang E, the goddess of the moon, was the wife of the famous archer Hou Yi. According to the legend, Chang E drank an immortality potion and rose to the moon where she lived with a white rabbit, becoming the quintessence of feminine ideologies (Lai, 1994; Masako, 1995). The *White Rabbit* has symbolic as well as mythic properties for the target market (women) and, therefore, serves as the perfect brand image to portray a feminine brand personality. Petty (2013) states that these ancient brands had symbolic value that identified the producer and carried certain cultural meaning regarding the use of the product. However, it is not clear whether the brand identities were central to the marketing strategy as is the case with modern brands.

The Song Dynasty was not only the start of the first complete brand but also the start of mass advertising (Starcevic, 2015). Landa (2005) proposes that block-printing started in China during the Song Dynasty and served as a preface for mass communication. This access to mass printing practices made it easy for manufacturers to print labels for their products. Hamilton and Lai (1989) state that distinguishable labels that use brand names were common at marketplaces across China from the fourteenth-century onwards. However, the invention of the modern printing press in the fifteenth-century transformed advertising into a craft of persuasion (Danesi, 2007). Organisations could now communicate their brand to potential consumers without being in direct contact with the consumer. This would become essential for organisations once the industrial revolution commenced.

MODERN BRANDING PRACTICES

The Industrial Revolution that occurred during the eighteenth-century focused on the efficiency of production (Varey, 2011). Consequently, production moved from individual producers to big factories. Consumers were no longer buying products from a local producer whom they knew personally. Generic products came from various factories from far away. Subsequently, the Industrial Revolution generated a need for organisations to create a personal certification to overcome the anonymity of these generic products (O'Barr, 2007). Roper and Parker (2006) argue that the Industrial Revolution set modern branding in motion.

Organisations had to present consumers with a brand with which they could start building a relationship that would lead to trust and loyalty. Therefore, organisations started using personification to create brands that could replace the trustworthy shopkeeper. Klein (2000) explains that this is why familiar personalities like *Dr. Brown*, *Uncle Ben* and *Aunt Jemima* were used as brand names during the nineteenth-century. Subsequently, advertising became more competitive. O'Barr (2007) explains that *Ivory Soap* had a distinctive appearance, logo and package design, and was advertised with scientific claims in the late 1800s. For that reason, *Pears' Soap*, a direct competitor of *Ivory Soap*, advertised their product using romantic images (O'Barr, 2007). Klein (2000) argues that by the start of the 1900s several organisations realised that brands could evoke a feeling. Ford was the leading automobile producer in the early 1900s until they were overtaken by General Motors (GM), who was selling more than just a car (Moreton, 2006). GM sold a feeling by telling the story about people who drove their cars, making it "something personal, warm and human" (Klein, 2000). Organisations had to adapt to and start selling more than only product features to convince consumers that their product was better than that offered by their competitors. Creating a brand with which consumers could connect with and relate to became essential.

Branding soon became part of most organisations' marketing campaigns but it was not until the 1940s that branding became part of a corporate identity (Suchman, 2007). Daffey and Abratt (2002) suggest that corporate identity moved from corporate image in the 1950s to corporate personality in the 1970s and 1980s, which eventually led to corporate brand management. Corporate branding became central to organisations and was defined by their unique identity and core values (Villagra & Lopez, 2015). Branding became such a central part of organisations that certain laws were put in place to protect brands. Petty (2016) argues that brand identity protection, such as trademarks, is necessary to protect organisations from imitators breaking consumers' trust. The development of modern brands was dependent on the development of trademarks (Duguid, 2009). These trademarks are of exceptionally high value and a well-established trademark may be sold for millions.

Maurya and Mishra (2012) argue that the focus on branding peaked during the 1980s, based on the increase in mergers and the very high valuation of brands as an intangible asset. In 1988, *Kraft* was bought for a staggering US\$12.6 billion, while the company was only valued at US\$2.1 billion (Newman, 2001). Moore (2003) referred to this defining transaction as “the brand equity mania of the eighties” (p. 338). The staggering price difference was paid towards the word *Kraft* (Moore, 2003). For the first time, a quantifiable amount was assigned to a previously unquantifiable organisational aspect - a brand name (Klein, 2000). This transaction changed the way branding was viewed. Brands became an intangible asset with a balance sheet value (Balmer & Gray, 2003). Consequently, organisations had to restructure to accommodate this newly identified asset.

The turn of the second millennium in 2000 marked a definite change in the composition of the management of organisations as brand directors and brand managers began to form an integral part of the team (Middleton, 2011). Jones and Bonevac (2013) propose that branding is probably a marketer’s most important job nowadays. All organisations need to realise the importance of branding.

IMPORTANCE OF BRANDING

Brands may be classified as one of the most important intangible assets of an organisation (Chung *et al.*, 2013). Consequently, branding is recognised as one of the most important marketing activities (Srinivasan *et al.*, 2011) and has become a top management priority (Keller & Lehmann, 2006). Todor (2014) argues that branding research increased over the past decades due to the prominent influence it has on an organisation’s performance. Branding is of value to both the organisation and the consumers (Ankomah Opoku *et al.*, 2007).

From the consumers’ perspective, a brand fundamentally helps the consumer to identify the producer of the product (Kotler & Armstrong, 2013). Consumers are bombarded with a vast number of different brands in an overcrowded marketplace. Therefore, branding is essential to help consumers find what they are looking for. Branding is especially valuable when consumers need to choose between products that are quite similar (Herman, 2003). Branding simplifies the choice by helping consumers to identify brands that have satisfied their needs in the past (Keller, 2013). Consumers know the reputation of the brand based on past experiences. Branding provides a level of reassurance regarding the quality of the product (Cant, 2011). Kotler and Keller (2012) argue that branding can provide an indication of consistency for consumers. The brand becomes a mark of quality assurance. When consumers repeatedly receive quality, it creates a sense of trust (Keller & Lehmann, 2006). Strong brands create a trust relationship with consumers based on the quality certification (Jobber, 2010). This sense of trust leads to a reduction of risk for the consumer when purchasing the brand (Mugesh, 2015).

Keller (2013) suggests that brands have a functional meaning as well as symbolic qualities for consumers. Consumers use brands to symbolise their self-image and to express themselves (Cant, 2011; Kim & Hall, 2014). Certain brands exhibit certain symbolic qualities. Consumers use brands to enhance their own image (Kotler & Armstrong, 2013). Consequently, consumers purchase these brands to portray a specific public image and to fit in among a specific crowd. The symbolic meanings attached to a brand are either assigned by consumers or designated by the brand’s marketers (Sung *et al.*, 2015). Organisations can use this symbolism attached to a brand strategically to position the brand within the market to influence consumer behaviour. Furthermore, branding also offers organisations several benefits.

From an organisational perspective, organisations essentially use brands as a form of identification to simplify logistics and to serve as a marker of the organisation’s offerings (Mugesh, 2015). Branding also helps the organisation to communicate information regarding the product to their consumers (Chung *et al.*, 2013). Wood (2000) contends that a brand often provides the key distinction between competitive offerings, which could be crucial for the success of the organisation. There are several brand-related aspects, influential to the organisation’s competitive advantage, which could be protected by intellectual property rights. The brand name can be protected in the form of registered trademarks, packaging by means of copyright and unique production processes by patents (Keller, 2013). These aspects have an impact on how consumers perceive the organisation. By protecting these brand-related aspects, the organisation can keep their competitive advantage. This ensures that competitors cannot use the brand’s success for their own gain. For this reason, organisations spend vast amounts of money on the development and protection of their brands (Masterson & Pickton, 2010).

As indicated earlier, brands communicate information regarding a product as well as a promise regarding the quality. If an organisation continually delivers on this promise, consumers will return time after time. Branding creates a platform for consumers to become brand loyal (Du Toit & Erdis, 2013). As such, consumers start to link the brand with dependability. Furthermore, loyal consumers will be less likely to switch to another brand, even if there is a price increase (Cant & Van Heerden, 2013). Consequently, an organisation with a strong brand is able to charge premium prices, which will lead to higher profits (Jobber, 2010). In addition, new products can be introduced with greater ease if an organisation has an established brand. Loyal consumers are familiar with the brand and, as such, are more likely to trust the new product based on their familiarity with the brand. Therefore, branding can assist in the selling of new products and in faster consumer acceptance, based on the reputation of an established brand (Lamb *et al.*, 2011; Du Toit & Erdis, 2013).

Brands can influence consumer behaviour and guarantee sustainable future profits (Keller, 2013). For this reason, brands have become an extremely valuable intangible asset for an organisation. Jobber (2010) suggests that strong brands enhance the financial value of an organisation; hence, a brand is a financial asset for an organisation (Mugesh, 2015). Masterson and Pickton (2010) point out that the financial value of a brand can be referred to as the brand equity.

BRAND EQUITY

The strength of a brand can be measured with brand equity by means of adding a monetary value to the brand name (Jobber, 2010; Lamb *et al.*, 2010). Aaker and Joachimsthaler (2012) define brand equity as all the assets or liabilities associated with a brand name. Brand equity adds to the value provided by the product or service and may, therefore, be explained as the positive differential effect that a brand name has on a consumer's behaviour (Kotler *et al.*, 2010). That is, branding is the increase in profit or demand based on the influence of the brand's name (Kapferer 2008).

Brand equity is a complex phenomenon and the measurement thereof is widely debated (Wood, 2000). Veloutsou *et al.* (2013) identify two different approaches to brand equity, namely the consumer-based approach and the firm-based approach. The consumer-based brand equity approach focuses on the consumers' perception of the brand over time (Kotler & Keller, 2012). The firm-based brand equity approach focuses on the financial value of the brand (Aggarwal *et al.*, 2013). Schiffman and Kanuk (2014) argue that consumer perceptions of the brand's superiority influence the financial value of the brand. Consequently, brand equity may be considered a consumer-based concept.

Numerous brand equity models have been developed, of which the two most prevalent models are Keller's (1993) and Aaker's (1996) (Klopper & North, 2011; Jooste *et al.*, 2012; Kotler & Keller, 2012). Keller's model is a consumer-based brand equity model that focuses on brand knowledge. Keller's model is subdivided into two dimensions of brand knowledge, namely brand awareness (brand recall and brand recognition) and brand image (type, favourability, strength and uniqueness of brand associations). The model focuses on the brand image dimension by going into more detail regarding the types of brand association specifically. The types of brand association include attributes (product-related and non-product-related), benefits (functional, experiential and symbolic) and attitudes. There are some definite similarities between Keller's model and Aaker's Brand Equity model, also known as the Brand Equity Ten. Aaker (1996) describes market behaviour, brand awareness, perceived quality, brand loyalty and brand associations as indicators of brand equity. David Aaker is considered the father of modern branding based on his ground-breaking work regarding brand equity (Adamson, 2015). For the purposes of this paper, Aaker's Brand Equity Ten will be used to outline the factors that influence brand equity. Furthermore, the two dimensions (brand awareness and brand associations) identified by Keller (1993) are also covered under Aaker's Brand Equity model.

Aaker's Brand Equity model

According to Aaker (1996), a brand equity model comprises the five categories of market behaviour, brand awareness, perceived quality, brand loyalty and brand associations.

The market behaviour of a brand is the only brand equity measure (of the Brand Equity Ten) where no consumer inputs are required, as the measure utilises market share, market price and distribution coverage (Aaker,

1996). Consequently, this measure is relatively objective and quantifiable (Phipps *et al.*, 2010). It should be noted that market behaviour aspects are not applicable when measuring consumer-based brand equity as it is considered as a firm-based approach to brand equity (Veloutsou *et al.*, 2013). The remaining four categories are classified as consumer-based approaches to brand equity.

Brand awareness may be defined as the extent to which a consumer can recall and recognise a particular brand (Du Toit & Erdis, 2013). Macdonald and Sharp (2003) suggest that no communication can take place between the organisation and consumer without brand awareness. A consumer needs to be aware of a brand before they will purchase the brand. The strategic importance of brand awareness is often underestimated (Aaker & McLoughlin, 2010). Brand awareness forms the foundation of brand equity (Kotler & Keller, 2012) and is the groundwork for all other connections with the brand (Jooste *et al.*, 2012). Brand awareness plays a vital role in the recall and recognition of a brand (Saleem *et al.*, 2015). Most organisations want to be recognised by potential consumers (Cant & Van Heerden, 2013). When brand awareness exists, an organisation's brand forms part of a consumer's consideration set (Macdonald & Sharp, 2003). If a consumer considers the brand when making a purchase decision, the chance of an actual purchase exists. Therefore, organisations need to strive to achieve brand awareness among potential consumers. Several authors (Yoo *et al.*, 2000; Berry, 2000; Kim & Hyun, 2011) indicate that there is a positive relationship between brand awareness and brand equity. However, Neerakkal (2012) suggests that brand awareness alone is not a sufficient measure of brand equity and needs to be used in collaboration with other brand equity dimensions.

Perceived quality may be defined as the subjective judgement consumers have regarding the brand's quality and superiority compared to its closest competitors (Zeithaml, 1988; Chi *et al.*, 2009; Keller, 2013). Consumer perceptions regarding the quality of a brand impact brand preference as well as the brand's equity (Gill & Dawra, 2010). Organisations can position their brand based on quality to differentiate the brand from competitors (Jooste *et al.*, 2012). Yoo *et al.* (2000) argue that brands that are perceived as being of a higher quality are often viewed as being superior to competitors' offerings. The superiority of a brand may be measured using leadership measures, as mentioned by Aaker (1996) as part of the Brand Equity Ten. Leadership measures strive to determine the brand's popularity and perception of innovativeness among consumers. Leadership measures also aim to determine whether consumers view the brand as one of the top brands in a product class (Aaker, 1996). Consumers will be more willing to purchase a brand that is considered as the top brand in a product category based on the quality assurance. Consequently, higher quality brands can often charge premium prices based on the higher value attached to the brand (Dibb *et al.*, 2012). Quality brands may, therefore, be viewed as more valuable from an organisation's perspective, and may lead to higher brand equity.

Brand loyalty may be defined as the willingness or preference of a consumer to purchase the same brand recurrently (Jooste *et al.*, 2012; Lamb *et al.*, 2013). Brand loyalty is at the core of brand equity (Aaker, 1996; Moisesescu, 2007) as it can be considered as the ultimate consumer-learning outcome for an organisation (Schiffman *et al.*, 2010). Tong and Hawley (2009) agree, stating that brand loyalty may be considered as the most important brand equity dimension. Loyal consumers are often returning consumers, who are exceptionally valuable to an organisation. Jooste *et al.* (2012) suggest that it is more expensive to attract a new consumer than retain a current consumer. Furthermore, Reichheld (2001) suggests that loyal consumers help to keep costs down by lowering new consumer acquisition costs through effective word-of-mouth marketing. A loyal consumer base may be viewed as an asset and, therefore, an important aspect of brand equity. Aaker and McLoughlin (2010) explain that brand loyalty is an asset as it is difficult to persuade loyal customers to consider an alternative brand. Loyal consumers are also less price-sensitive and would be willing to pay more for a familiar brand than for competitors' products with the same benefits. Aaker (1996) refers to this phenomenon as the price premium part of the Brand Equity Ten and argues that price premium may be the most reliable indicator of brand equity, as a change in all the other measures will directly influence the price a consumer would be willing to pay for a particular brand.

Brand associations may be defined as "all brand-related thoughts, feelings, perceptions, images, experiences, beliefs, attitudes..." that the consumer attaches to a brand (Kotler & Keller, 2012, p. 164). Keller (2013) highlights the importance of the strength, favourability and uniqueness of all the brand associations as a differential response that constitutes brand equity. Chen (2001) suggests that brand associations are a result of a link between two nodes in the consumer's mind. In other words, a consumer links a certain memory with the brand, resulting in specific brand associations (Fayrene & Lee, 2011). These associations may be directly or indirectly related to the brand (Aaker &

McLoughlin, 2010). Aaker (1996) argues that brand associations may be viewed from three different perspectives, namely the brand as an organisation, a person or a product.

The perception of the brand as a product focuses on the value proposition that a brand creates (Aaker, 1996). Brown and Dacin (1997) define organisational associations as all the perceptions, beliefs, emotions and information about an organisation in the consumer's mind. The last aspect that may influence brand associations is the perception of the brand as a person. Aaker (1996) states that this perception is effective when the brand is consumed in a social setting and may enhance the consumer's image visibly. Keller (1993) classifies brand personality as a non-product-related attribute that influences emotions and feelings regarding a brand. A brand can sometimes reflect personality traits and values similar to those of consumers (Keller, 2001), which, consequently, may influence their behaviour. Brand personality is a key factor influencing brand associations and brand equity (Pappu *et al.*, 2005). Furthermore, Masterson and Pickton (2010) argue that brand personality is at the core of an organisation and influences brand identity, brand image and, ultimately, brand equity.

CONCLUSIONS AND MANAGERIAL IMPLICATIONS

This paper analysed various definitions of branding to derive a new definition for the term branding. This definition guided a literature review to identify branding practices through history. Branding has evolved over the past nine milliniums from only being a mark of ownership to the most important distinguishing factor for the modern brand. The increase in competitors in the market led to the use of branding as a differentiator by means of emotional associations to the brand. Competition became so fierce that it was crucial for organisations to implement branding as part of their corporate image. Consumers became acquainted with brands and the associations attached to them, and started using these associations to help them to make purchasing decisions. Likewise, organisations realised the importance of branding for the organisation's success. Brands became a valuable intangible asset with financial worth. This sparked a change in how organisations viewed and managed brands. Brand equity became an important component of measuring a brand's success. Organisations need to be aware of what branding entails and the prominent role it plays in the overall success of the organisation.

As with all studies, this paper do have certain limitations. This paper focused on the development of brands through history until the early 2000's. The influence of the digital age in the twenty-first century on branding was not assessed. Future research can further analyse the influence of the internet and specifically social media on branding of modern brands and how consumers engage with brands. Furthermore, this paper only looked at the measurement of brand equity from the perspective of Aaker (1996) and Keller (1993). Future research could also consider other measures of brand equity.

REFERENCES

- Aaker, D.A. (1996). Measuring brand equity across products and markets. *California management review*, 38(3):102-120.
- Aaker, D.A. (2009). *Managing brand equity*. Simon and Schuster.
- Aaker, D.A. (2014). *Aaker on branding: 20 Principles That Drive Success*. New York: Morgan James Publishing.
- Aaker, D.A. and Joachimsthaler, E. (2012). *Brand leadership*. Simon and Schuster.
- Aaker, D.A. and McLoughlin, D. (2010). *Strategic market management: global perspectives*. John Wiley & Sons.
- Adamson, A. (2015). Winning Lessons From Nike, Patagonia And Other Marketing Hall Of Famers. <http://www.forbes.com/sites/allenadamson/2015/05/26/winning-lessons-from-nike-patagonia-and-other-marketing-hall-of-famers/#20de91b2208c> Date of access: 28 June 2015.

- Aggarwal, S.A., Rao, V.R. & Popli, S. (2013). Measuring consumer-based brand equity for Indian business schools. *Journal of marketing for higher education*, 23(2):175-203.
- Ankomah Opoku, R., Abratt, R., Bendixen, M. & Pitt, L. (2007). Communicating brand personality: are the web sites doing the talking for food SMEs?. *Qualitative Market Research: An International Journal*, 10(4):362-374.
- Balmer, J.M. & Gray, E.R. (2003). Corporate brands: what are they? What of them? *European Journal of marketing*, 37(7/8):972-997.
- Berry, L.L. (2000). Cultivating service brand equity. *Journal of the Academy of marketing Science*, 28(1):128-137.
- Brown, T.J. & Dacin, P.A. (1997). The company and the product: Corporate associations and consumer product responses. *The Journal of Marketing*, 68-84.
- Cant, M.C. & Van Heerden, C.H. (2013). *Marketing Management, a South African perspective*. Juta.
- Cant, M.C. ed. (2011). *Marketing management: a South African perspective*. Juta and Company Ltd.
- Chen A.C.H. (2001). Using free association to examine the relationship between the characteristic of brand association and brand equity. *Journal of Product & Brand Management*, 10(7):439-451.
- Chi, H.K., Yeh, H.R. & Yang, Y.T. (2009). The impact of brand awareness on consumer purchase intention: The mediating effect of perceived quality and brand loyalty. *Journal of International Management Studies*, 4(1):135-144.
- Chung, T. W., Jang, H. M. & Han, J. K. (2013). Financial-based brand value of Incheon international airport. *The Asian Journal of Shipping and Logistics*, 29(2):267-286.
- Committee on Definitions. (1960). *Marketing Definitions: a glossary of marketing terms*. Chicago: American Marketing Association.
- Daffey, A. & Abratt, R. (2002). Corporate branding in a banking environment. *Corporate Communications: An International Journal*, 7(2):87-91.
- Danesi, M. (2007). *Why it sells: Decoding the meanings of brand names, logos, ads, and other marketing and advertising ploys*. Rowman & Littlefield Publishers.
- De Chernatony, L. & Dall'Olmo Riley, F. (1998). Defining a "brand": Beyond the literature with experts' interpretations. *Journal of Marketing Management*, 14(5):417-443.
- Dibb, S., Simkin, L., Pride, W.M. & Ferrell, O.C. (2012). *Marketing: concepts and strategies*. 6th ed. Andover: South-Western Cengage Learning.
- Dranove, D. & Jin, G. Z. (2010). *Quality disclosure and certification: Theory and practice* (No. w15644). National Bureau of Economic Research.
- Du Toit, M. & Erdis, C., eds. (2013). *Fundamentals of branding*. Cape Town: Juta.
- Duguid, P. (2009). French connections: The international propagation of trademarks in the nineteenth century. *Enterprise and Society*, 10(01):3-37.
- Eckhardt, G.M. & Bengtsson, A. (2010). A brief history of branding in China. *Journal of Macromarketing*, 30(3):210-221.

- Fayrene, C.Y. & Lee, G.C. (2011). Customer-based brand equity: A literature review. *Researches World*, 2(1):33-42.
- Gill, M.S. & Dawra, J. (2010). Evaluating Aaker's sources of brand equity and the mediating role of brand image. *Journal of Targeting, Measurement and Analysis for Marketing*, 18(3):189-198.
- Grace, V. (1979). *Amphoras and the ancient wine trade* (Vol. 16). ASCSA.
- Hamilton, G.G. & Lai, C.K. (1989). Consumerism Without Capitalism: Consumption and Brand names in Late Imperial China (In Brown, R.A., 1996. *Chinese business enterprise* (Vol. 3). Taylor & Francis. 315-336).
- Herman, R. (2003). An exercise in early modern branding. *Journal of Marketing Management*, 19(7-8), 709-727.
- Holleran, C. (2012). *Shopping in Ancient Rome: the retail trade in the late Republic and the principate*. Oxford University Press.
- Jahandoost, M. & Bahrami, S. (2013). Investigating the effects of Iranian cultural factors on brand equity for strategic management of market share. *Management Science Letters*, 3(12):3047-3058.
- Jobber, D. (2010). *Principles of Marketing* 6th ed. McGraw-Hill.
- Jones, C. & Bonevac, D. (2013). An evolved definition of the term 'brand': Why branding has a branding problem. *Journal of Brand Strategy*, 2(2):112-120.
- Jooste, C.J., Strydom, J.W., Berndt, A. & Du Plessis, P.J. (2012). *Applied strategic marketing*. 4th ed. Cape Town: Pearson.
- Kapferer, J.N. (2008). *The New Strategic Brand Management*, 4th ed., London: Kogan Page.
- Kapferer, J.N. (2012). *The new strategic brand management: Advanced insights and strategic thinking*. Kogan Page Publishers.
- Keller, K.L. (1993). Conceptualizing, measuring, and managing customer-based brand equity. *The Journal of Marketing*:1-22.
- Keller, K.L. (2001). Building customer-based brand equity: A blueprint for creating strong brands. <http://www.academia.edu/download/40863813/CustomerBasedBrandEquityModel.pdf> Date of access: 15 September 2015
- Keller, K.L. (2013). *Strategic Brand Management: Building, Measuring, and Managing Brand Equity* 4th global ed. Essex:Pearson.
- Keller, K.L. & Lehmann, D.R. (2006). Brands and branding: Research findings and future priorities. *Marketing science*, 25(6):740-759.
- Khan, S. & Mufti, O. (2007). The Hot History & Cold Future of Brands. *Journal of Managerial Sciences*, 1(1):75-87.
- Kim, H.S., & Hall, M.L. (2014). Fashion Brand Personality and Advertisement Response: Incorporating a Symbolic Interactionist Perspective. *Fashion Branding and Consumer Behaviors* (pp. 29-45). Springer New York.
- Kim, J.H. & Hyun, Y.J. (2011). A model to investigate the influence of marketing-mix efforts and corporate image on brand equity in the IT software sector. *Industrial marketing management*, 40(3):424-438.
- Klein, N. (2000). *No Logo*. London: Flamingo.

- Klopper, H. B. (2013). *Marketing*. 4th Ed. Cape Town: Oxford University Press.
- Klopper, H.B. & North, E. 2011. *Brand management*. Cape Town: Pearson Education.
- Kotler, P. & Armstrong, G. (2013). *Principles of marketing*. 15th global edition. New York: Pearson).
- Kotler, P. & Keller, K. 2012. *Marketing Management*. 14th Edition. Upper Saddle River: Pearson Education.
- Kotler, P., Armstrong, G.M., Tait, M., Bhowan, K., Botha, E., De Jager, J., George, R., Human, D., Roberts-Lombard, M., Rugimbana, R. & Vigar-Ellis, D. (2010). *Principles of marketing: Global and Southern African perspectives*. Cape Town: Pearson Education South Africa.
- Kumar, S.J. (2014). *Brand building and positioning with reference to pharmaceutical industry*. Mumbai: S.N.D.T Women's University (PhD Thesis).
- Lai, W. (1994). Recent PRC Scholarship on Chinese Myths. *Asian Folklore Studies*, 53(1):151-161.
- Lamb, C.W., Hair, J.F. & McDaniel, C. (2011). *Essentials of marketing*. Cengage Learning.
- Lamb, C.W., Hair, J.F., McDaniel, C., Boshoff, C., Terblanche, N., Elliott, R. & Klopper, H. (2010). *Marketing*. 4th ed. Cape Town: Oxford University Press South Africa.
- Landa, R. (2005). *Designing Brand Experience: Creating Powerful Integrated Brand Solutions*. Clifton Park: Cengage Learning.
- Macdonald, E. & Sharp, B. (2003). Management perceptions of the importance of brand awareness as an indication of advertising effectiveness, *Marketing Bulletin*, 14(2).
- Masako, M. (1995). Restoring the "Epic of Hou Yi". *Asian folklore studies*, 239-257.
- Masterson, R. & Pickton, D. (2010). *Marketing: an introduction*. SAGE Publications.
- Maurya, U. K., & Mishra, P. (2012). What is a brand? A Perspective on Brand Meaning. *European Journal of Business and Management*, 4(3):122-133.
- Middleton, S. (2011). *What you need to know about marketing*. Chichester: Capstone Publishing.
- Moisescu, O.I. (2007). An analysis regarding descriptive dimensions of brand equity. *Management and marketing-craiova*, (1):132-139.
- Moore, K. & Reid, S. (2008). The birth of brand: 4000 years of branding. *Business History*, 50(4):419-432.
- Moore, R.E. (2003). From genericide to viral marketing: on 'brand'. *Language & Communication*, 23(3):331-357.
- Moreton, B. (2006). *The soul of the service economy: Wal-Mart and the making of Christian free enterprise, 1924/1994*. Yale University (Thesis: PhD).
- Mugesh, K. (2015). A Descriptive Study About Brand Marketing. *International Journal on eManagement*, 11:11-14.
- Neerakkal, J.A. (2012). An enquiry into selected marketing mix elements and their impact on brand equity. *The IUP Journal of brand management*, 9(2):29-43.

- Newman, K. (2001). The sorcerer's apprentice? Alchemy, seduction and confusion in modern marketing. *International Journal of Advertising*, 20(4):409-429.
- O'Barr, W.M. (2007). The Management of Brands. *Advertising & Society Review*, 8(1).
- Papadopoulos, J.K. & Paspalas, S.A. (1999). Mendaian as Chalkidian wine. *Hesperia*, 161-188.
- Pappu, R., Quester, P.G. & Cooksey, R.W. 2005. Consumer-based brand equity: improving the measurement - empirical evidence. *Journal of product and brand management*, 14(3):143-154.
- Petty, R.D. (2013). 'Towards a Modern History of Brand Marketing: Where Are We Now? (In Neilson, L.C. ed. (2013). *Varieties, Alternatives and Deviations in Marketing History: Proceedings of the 16th Biennial Conference on Historical Analysis and Research in Marketing, Copenhagen, Denmark: CHARM Association.*)
- Phipps, M., Brace-Govan, J. & Jevons, C. (2010). The duality of political brand equity. *European Journal of Marketing*, 44(3/4):496-514.
- Qu, H., Kim, L.H. & Im, H.H. (2011). A model of destination branding: Integrating the concepts of the branding and destination image. *Tourism Management*, 32(3):465-476.
- Reddi, C.N. (2009). Effective public relations and media strategy. PHI Learning Pvt. Ltd.
- Reichheld, F.F. (2001). Loyalty rules!: how today's leaders build lasting relationships. Boston: Harvard Business School Press.
- Roper, S. & Parker, C. (2006). Evolution of branding theory and its relevance to the independent retail sector. *Marketing Review*, 6(1).
- Saleem, S., Rahman, S.U. & Umar, R.M. (2015). Measuring customer based beverage brand equity: Investigating the relationship between perceived quality, brand awareness, brand image, and brand loyalty. *International Journal of Marketing Studies*,7(1):66-77.
- Schiffman, L. & Kanuk, L. (2014). Consumer behaviour: global and Southern African perspectives. Cape Town: Pearson.
- Schiffman, L.G., Kanuk, L.L. & Wisenblit, J. (2010). Consumer behavior, 10th ed. New Jersey: Pearson Prentice Hall.
- Sheth, J.N. & Parvatiyar, A. (1995). The evolution of relationship marketing). *International Business Review*, 4(4):397-418.
- Singh, G. (1971). The Indus Valley Culture: Seen in the Context of Post-Glacial Climatic and Ecological Studies in North-West India, *Archaeology & Physical Anthropology in Oceania*, 6(2):177-189.
- Srinivasan, S., Hsu, L. & Fournier, S. (2011). Branding and firm value. (In Ganesan, S & Bharadwaj, S., eds. (2011). *Handbook of Marketing and Finance*, Edward Elgar Publishing.)
- Starcevic, S. (2015). The Origin and Historical Development of Branding and Advertising in the Old Civilizations of Africa, Asia and Europe, *Marketing*, 46(3):179-196.
- Strizhakova, Y., Coulter, R.A. & Price, L.L. (2011). Branding in a global marketplace: The mediating effects of quality and self-identity brand signals. *International Journal of Research in Marketing*, 28(4):342-351.
- Suchman, L.A. (2007). Anthropology as "brand": reflections on corporate anthropology. Oxford University.

- Sung, Y., Choi, S.M., Ahn, H. & Song, Y.A. (2015). Dimensions of Luxury Brand Personality: Scale Development and Validation. *Psychology & Marketing*, 32(1):121-132.
- Todor, R.D. (2014). The importance of branding and rebranding for strategic marketing. *Bulletin of the Transilvania University of Brasov. Economic Sciences. Series V*, 7(2):59-64.
- Tong, X. & Hawley, J.M. (2009). Creating brand equity in the Chinese clothing market: the effect of selected marketing activities on brand equity dimensions. *Journal of fashion marketing and management*, 13(4):566-581.
- Twede, D. (2002). Commercial amphoras: the earliest consumer packages? *Journal of Macromarketing*, 22(1):98-108.
- Van Zyl, R. (2011). Branding: looks are important! (In Parker, E., ed. *Marketing your own business*. Northlands: Pan Macmillan, 61-113.)
- Varey, R.J. (2011). A sustainable society logic for marketing. *Social Business*, 1(1):69-83.
- Veloutsou, C., Christodoulides, G. & De Chernatony, L. (2013). A taxonomy of measures for consumer-based brand equity: drawing on the views of managers in Europe. *Journal of product and brand management*, 22(3):238-248.
- Villagra, N. & Lopez, B. (2015). The management of intangibles and corporate branding: Has anything changed in the relationship between business and society? *Revista Latina de Comunicación Social*, 70:793-812.
- Wengrow, D. (2008). Prehistories of commodity branding. *Current Anthropology*, 49(1):7-34.
- Wood, L. (2000). Brands and brand equity: definition and management. *Management decision*, 38(9):662-669.
- Yang, D., Sonmez, M. & Li, Q. (2012). Marks and Brands: Conceptual, Operational and Methodological Comparisons. *Journal of Intellectual Property Rights*, 17:315-323.
- Yoo, B., Donthu, N. & Lee, S. (2000). An examination of selected marketing mix elements and brand equity. *Journal of the academy of marketing science*, 28(2):195-211.
- Zeithaml, V.A. (1988). Consumer perceptions of price, quality, and value: a means-end model and synthesis of evidence. *The Journal of marketing*, 2-22.

LEAN SIX SIGMA MODEL FOR IMPROVING PRODUCTIVITY RATE OF STEEL MANUFACTURING SMEs

Thomas Thinandavha Munyai and Kgashane Stephen Nyakala,
Tshwane University of Technology, South Africa

Charles Mbohwa
University of Johannesburg, South Africa

ABSTRACT

The nature of steel manufacturing products and their processes expose small and medium-sized enterprises (SMEs) to a low productivity rate and late deliveries. Lean Six Sigma (LSS) is a leading technique in manufacturing and refining productivity rate and mathematical development. Although it permits exact measurement of mathematical developments and can uncover any waste and defect deviations from the product, its capability in sustaining/improving productivity rate is not well studied. This study presents a model to overcome this limitation by developing a LSS model to improve productivity rate in steel manufacturing SMEs. A quantitative research method was used in order to test the above issues. Those managers and supervisors of SMEs who are directly involved in steel manufacturing products are the scope of respondents in this study. The results provide managers with deep insight into the approaches for improving productivity rate. The significant p value of $0.000 < 0.05$ indicates that the model is statistically significant and that there is a strong relationship between productivity and LSS, and it also enhanced the team's knowledge of steel manufacturing processes. Based on the study findings, it was concluded that the proposed model substantially improves the steel manufacturing products and enhances the capability of the LSS technique.

Keywords: steel manufacturing; productivity rate; small and medium enterprise, improvement and Lean Six Sigma.

INTRODUCTION

The nature of steel manufacturing products and their processes poses immense challenges to the productivity rate of industrial practitioners. Statistics South Africa (2015), ILO (2015) and Schwab (2015) highlight that the productivity in steel manufacturing is continuously dropping. Coka (2014) postulates that the low productivity rate has a negative impact on the standard of living of people in South Africa. One of the key demands normally is that steel manufacturing industries should be more productive and compete in global markets regarding price, quality and delivery. On the other hand, there are many factors which cause uncertainty and that have a potential impact on productivity and the business to remain competitive in markets. In the manufacturing industry, which deals with these challenges, the influence of certainties is more prevalent, necessitating the need for effective engineering management. According to Teng (2014), productivity can be seen as output related to input. Productivity can generally be defined as the ratio of goods and services divided by resources such as labour and capital (Marsillac & Roh, 2014). In a manufacturing context, productivity is the efficiency with which the organisation turns inputs into outputs (Krajewski, Maholtra & Ritzman, 2016; Hamilton, Nickerson & Owan, 2015). This is clearly stated in most widely accepted definitions of productivity such as those of the Association for Productivity South Africa (Coka, 2014) and Steel and Engineering Industries Federation of South Africa (SEIFSA) (2015). In addition to this, according to SEIFSA (2015) the steel manufacturing industry contributes 17% to the South African gross domestic product (GDP). Steel manufacturing remains a complex and need the balance of input resource factors such as

human, material, machinery, finance, technology, layout and location and external input resource factors such as competitiveness and government support.

Researchers have always emphasised the importance of developing maximum productivity within a business to use its resources wisely and to differentiate it from competitors to achieve advantage (OECD, 2013; Caskey, 2015; Hedley, 2015; Mutalemwa, 2015; Prasad and Prakas, 2015). Competitiveness of manufacturing SMEs refers to “management of capabilities to use wisely its resources, competencies and knowledge, and also manage the change with the overall objectives of adapting better and faster than competition” (Belay, Helo, Takala and Welo, 2014). In terms of steel manufacturing products, resources and competence are two of the essential and significant areas when it comes to productivity (Coka, 2014; Seda, 2014). Hence, in manufacturing steel products, which generally comprises a substantial amount of cost investment, it is of utmost importance to reduce waste in the interest of both the business and the customer. It is, however, worthy of note that improved productivity is the optimum combination and maximum utilisation of all production factors present in the manufacturing processes so as to reduce costs economically within the organisation intending to maximise the profitability in the long term (Jagoda, Longseth and Longseth, 2013; Parnell Long and Lester, 2015).

Thus, the objectives of this study are:

- 1) To investigate strategies on resources and tools to improve productivity in the steel manufacturing industry in South Africa using the Lean Six Sigma approach.
- 2) To develop a dynamic system model for optimising the productivity rate of steel manufacturing industries.

LITERATURE REVIEW

This section focuses on the contribution of steel manufacturing SMEs to improve productivity rate and development of the LSS model. The discussion below indicates that SMEs in the steel sector positively impact on South African gross domestic product (GDP), employment and economic growth as well as enhancing skills development in South Africa.

Lean concept

Lean is a corporate manufacturing system which concentrates on identifying and eliminating non-value activities, reducing waste, maximising capacity and decreasing inventory (Mohanraj, Sakthivel & Vinodh, 2011). In steel manufacturing processes, lean aims to produce high quality products and services at the lowest possible cost and to improve productivity with maximum consumer awareness. In doing so, a clear focus on these aims should reduce wastage while still enhancing productivity in the manufacturing environment as well as increasing efficiency and competitiveness (Fore & Mbohwa, 2010).

Akbulut-Bailey, Motwani & Smedley (2012) identify five (5) fundamental steps in applying the lean concept, namely value identification (value product as perceived by customer), value stream analysis (elimination of non-value adding activities), flow (continuous manufacturing process without interruption), pull (orders are produced after the customer placed an order) and perfection (manufacturing concentrating on continuous improvement and regular elimination of non-value adding processes). Laureani and Antony (2012) describe lean as a process improvement methodology used to deliver products and services better, faster, and at a low cost. This study shows that the information provided by the lean operation creates a production system which is highly adaptive to meet market demands. Figure. 1 shows five phases of the LLS DMAIC for steel manufacturing SMEs. Lean can be considered a reliable factor for avoiding deficiencies in aspects such as competitiveness, organisation, know-how, government departments and finance in steel manufacturing SMEs (Al-Najem, Dhakal, Labib & Bennett, 2013). A significant number of publications highlight that increased global competition is pressuring the steel industry to transform their manufacturing pattern from mass manufacturing to lean manufacturing (Fore & Mbohwa, 2010; Laureani & Antony, 2012; Kumar, Singh, Qadri, Kumar & Haleem, 2013).

Six Sigma concept

The purpose of the establishment and development of Six Sigma in steel SMEs is to reduce process variation of output with an aim of reducing variability to levels below 3.4 defects per million opportunities (DPMO) and customer satisfaction (Prashar, 2014). The paper will highlight the importance of using Six Sigma in steel SMEs aiming for consistent quality, in order to reduce inconsistency. The difficulties of inconsistency, poor process performance, late deliveries and low productivity could be overcome by the improvement of Six Sigma methods. Ghaleb, El-Sharif and E-Sebaie (2015) and Sin, Zailani, Iranmanesh and Ramayah, (2015) clearly state that the growth and sustainability of manufacturing SMEs can be monitored through the use of Six Sigma as business strategy to improve efficiency and customer satisfaction by decreasing operating costs whilst increasing profits. In order to address the challenges of low productivity rate and late deliveries in the steel manufacturing industries, more attention and focus should be directed to the organisation and systematic processes such as statistical and scientific methods in order to ensure customer satisfaction (Prashar, 2014a).

Using Six Sigma as the five steps of DMAIC, (which are define, measure, analyse, improve and control) in the steel manufacturing industries, could promote successful steel manufacturing SMEs. Findings based on the survey indicate that successful steel SMEs can positively improve manufacturing products in South Africa. Chay, Xu, Tiwari & Chay (2015) support the use of DMAIC as a strategy to improve productivity rate through supplying quality products at the right time, quantity and price as needed by customers. The use and development of DMAIC phases depend on the effectiveness and efficiencies of business proficiency. In that respect, these phases and corresponding methods eliminate mistakes and defects, improve market share and profitability, as well as ensure customer satisfaction (Desai, Kotadiya, Makwana & Patel, 2015).

Jesus, Anthony, Lepikson & Cavalcante (2015:96) also note that a detailed Six Sigma aims to exceed customer expectation and enhance business profitability. In fact, Jesus *et al.* (2015) also mention that Six Sigma, making use of five steps (DMAIC), is applied on two levels, as development of new products and productivity improvement in steel manufacturing SMEs. Therefore, efforts from all parties are needed to develop teams that have a good understanding of the application of Six Sigma in order to enhance productivity in steel manufacturing SMEs.

Lean Six Sigma concept

A considerable body of literature has shown that Lean Six Sigma (LSS) is a technique for improving productivity and quality in manufacturing processes (Hoerl & Gardner, 2010; Jayaraman, Key and So, 2012; Manville, Greatbanks, Krishnasany and Parker 2012:9; Assarlind, Gremyr and Backman, 2013; Habidin & Yusof, 2013). For example, Hoerl & Gardener (2010) and Manville *et al.* (2001) suggest that integration of Lean and Six Sigma (LSS) should enable these manufacturing organisations, be they large or small, to benefit from both types of improvement, commitment and assessment to improve productivity rate and cost reduction by eliminating non-value-adding activity. It is important for the manager to encourage the development of learning capabilities, providing employees with skills and tools required in work processes (Hoerl & Gardener, 2010; Hamilton *et al.*, 2015; Jesus *et al.*, 2015).

The term *Lean Six Sigma* is particularly defined as the combination of the best features of Lean and Six Sigma in the pursuit of sustained improvement, concentrating on maximisation of value, quality, process speed, reduced cost, and improvement in customer satisfaction (Akbulut-Bailey *et al.*, 2012). On the other hand, according to Ghaleb *et al.* (2015), LSS aims at minimum utilisation of resources (human, material and capital) and at swiftly meeting customer expectations.

Assarlind *et al.* (2013) find that LSS reduces machine downtime and flow time, removes waste, whilst improving productivity rate and customer satisfaction. The paper by Habidin & Yusof (2013) points out how steel manufacturing SMEs improved productivity rate when Lean and Six Sigma were applied in elimination of waste, saving cost, non-value activities and design of product. From the results and conclusions from each strategy included in this study, it is clear now that the LSS model is not simply a trend but can benefit all steel manufacturing SMEs (improve productivity, eliminate waste, increase customer satisfaction, save cost, increase market share and much more). The study by Soda, Sachdeva & Garg (2015) analyses the significance and willingness of steel

manufacturing SMEs to implement Lean and Six Sigma in improving productivity in their businesses. Other researchers have found that the manufacturing industry has generally been slow to adopt and implement effective Lean Six Sigma principles (de Carvalho, Ho and Pinto, 2014).

Successful application of LSS requires organisational effectiveness, operation and review, as well as management commitment at all levels of an organisation. Lean operation and Six Sigma can be described as an approach to organisational change and improvement, a method to reduce cost within firms or industries (Prasad & Prakash, 2015; Krajewski *et al.*, 2016). It was also officially recommended by the Ministry of Trade and Industry, as an approach for resolving productivity problems in the manufacturing industry and for meeting customers' needs. Desai *et al.* (2015) find that most business are adopting LSS to modify their manufacturing process and increase efficiency and productivity. Hessels & Parker (2013) postulate that LSS is aimed at attaining long-term competitive advantage in the manufacturing processes of SMEs and sustainability of business productivity development. In addition to this, it is observed that tools such as Total Preventive Maintenance (TPM) which puts emphasis on improving machine availability and quality-management initiatives are used. The DMAIC (define, measure, analyse, improve and control) phases are the methodology used to solve low productivity in SMEs incorporating LSS improvement tools.

Define Phase: The define phase is the statement of the problem and the naming of project team members or stakeholders (Srinivasan, Muthu, Devadasan and Sugumaran, 2016). Supervisors must strive to establish the LSS DMAIC model in the steel manufacturing industry in an effort to improve productivity rate and manufacturing process (Salah, Rahim & Carretero, 2010; Mathur, Mittal & Dangayach, 2012; Parris, 2013; Prasad & Prakash, 2015). A comprehensive list of DMAIC competencies was developed from a literature review. The define phase should be completed before the work commences; this comprises identifying the problem, followed by analysis of a supplier, input, process, output and customer (SIPOC) (Jirasukprasert, Garza-Reyes, Kumar & Lim, 2014; Krajewski *et al.*, 2016). The conclusion is that it could also apply to South African manufacturing SMEs (Table 4). Irrespective of this, it will be a violation of expansion practices if the manager or supervisor who makes decisions is misled with regards to manufacturing productivity level and review. Thus, the supervisor's in the development of LSS DMAIC is the key to understanding the deficiencies of the manufacturing process that hinder productivity in relation to waste level, profitability, and equipment availability. In efforts to keep this study specific to the manufacturing industry, the researchers required that expert members have a minimum of six (6) years professional experience relating to, appropriate for, or involved in the manufacturing industry. Figure 1 presents the proposed LSS DMAIC model in the steel manufacturing process.

Measure Phase: Organisations have arrived at the conclusion that measuring job performance can improve their competitive abilities and increase turnover in the marketplace (Snee, 2010). Various researchers also report that measuring job performance has led to improvements in productivity, quality and competitiveness in firms that have done so (Snee, 2010; Sin, Zailani, Iranmanesh & Ramayah, 2015; Schwab, 2015). A study conducted by Jagoda, Lonseth & Lonseth (2013) indicates a 90% improvement rate in operating procedures, employee relations, customer satisfaction, and financial performance due to measuring of job performance. De Mast & Lokkerbol (2012) indicate how to measure the capability of the steel manufacturing process by considering productivity rate, types of waste and plant efficiency. They indicate that the measuring phase should focus on productivity baseline and quantifying in terms of cost implication for poor quality and improvement. Studies by Chiarini (2011) and Belekoukias, Garza-Reyes & Kumar (2014) classify the types of waste and presented through Pareto and map the cause and effect diagram considering input resource factors such human, method, material and machinery and environment contributing to low productivity.

Analyse Phase: Prashar (2014) describes that during the analyse phase the project team assesses measurement collected during the previous phase, brainstorms parameters contributing to the low productivity and presents a cause and effect diagram. Some authors have found that, for both the manufacturing and service industries, the analysis phase provides detailed Value Stream Mapping (VSM), Analysis of Pareto, ANOVA correlation and multiple regression. Chiarini (2011) notes that VSM controls information and material flow and that it assists in identifying non-value-adding activities in steel manufacturing. Vinodh, Selvaraj, Chinta and Vimal (2015) also report that value stream mapping is about identifying waiting time and transport (both employee and material) in order to ensure employee productive work and improve flow of material.

The phase of analysing provides an overview of manufacturing processes and possible causes of problems relating to low productivity. Here the Pareto principle, namely that 80 percent of problems in operations are created by 20 percent of causes (Jirasukprasert *et al.*, 2014), can be applied as a tool to classify the cases according to the degree of importance and then resolving the most important and leaving less important on a principle of 80/20 (Mathur *et al.*, 2012). During this phase the suggestions are debated and will be tested in the next phase.

Improve phase: Prashar (2014) indicates that improving production planning of desirable manufacturing processes does not happen by chance, rather it must rely on identifying the possible solution to address low productivity rate in the organisations. The improvement phase focuses on the development of the strategies that will advance productivity levels in these industries and eliminate waste (Salah, *et al.*, 2010; Prasanna & Vinodh, 2013; SEIFSA, 2015). These same authors recommend that organisations establish a DMAIC model for improving the productivity rate in the manufacturing or other service industries. This means that productivity improvement needs a dedicated workforce to continuously improve the complex manufacturing process with dynamic input resources factors. In order to achieve improved productivity in these industries, the suggested solutions are integrated in future formal maps and measurements planned frequently to ascertain the improvement data. Continuous improvement in every phase of LSS ensures that a sustainable solution is achieved which requires the last next stage of DMAIC.

Control phase: Garza-Reyes (2015) highlights the significance of creating monitoring and evaluation systems for achieving and implementing the solutions of the previous phase. Control is regarded as the last phase of the LSS DMAIC model that ensures the problems of low productivity are resolved completely. 5S good housekeeping (daily) improves efficiency and eliminates accidents. SPC (statistical process control -daily) improves product quality. Benchmarking and brainstorming on Value stream mapping (Weekly to Monthly) deals with waste removal and non-value activity. Quality improvement through Kaizen (daily) improves productivity. Pareto analysis (quality and production meeting) eradicates defects. Cause and effect analysis (Monthly) deals with difficulties in the manufacturing process.

Training and development of employees on LSS programmes take place quarterly. The process teams use audit reports on a monthly basis, and corrective action is taken to mitigate the variations. Standard Operating Procedure (SOP) is developed and adhered to, based on the improvement outlined in Figure 1. Based on real system analysis, the following LSS framework was developed from the literature review and real-world manufacturing system analysis of Gauteng SMEs. The LSS DMAIC, depicted in Figure 1, specifies the application of LSS to input resource factors and the DMAIC phase in problem solving to improve productivity in these SMEs. In short, LSS can be regarded as the state of the art approach and its application envisioned to be used in productivity development in steel manufacturing.

RESEARCH METHODOLOGY

A quantitative research method was adopted in order to test the above issues. The questionnaire comprised two parts: SMEs steel manufacturing productivity rate and the development of a LSS model; and factors that influenced the development of LSS model. It can further be stated that case time study observation was explored to generate a sustainable model.

Research Design

The study adopted a descriptive and exploratory research design to investigate strategies and tools to improve productivity in the steel manufacturing industry in South Africa using a Lean Six Sigma approach.

Population

The population consisted of the SME managers/supervisors in the Gauteng Metropolitan areas, Gauteng Province of South Africa.

Sample and Sampling Techniques

This paper used a purposive and stratified sampling technique to select one-hundred-and-eighty-one (181) SME managers/supervisors and the sample size was determined based on the Cochran relation. Before the actual survey was conducted, a pilot study was carried out to test the validity and reliability. Factor analysis was done to investigate the proposed model of the variables that were adopted in the study. Varimax rotation factor analysis was employed to ensure the questionnaire items had high correlation between the identical factors and low inter-correlation regarding other factors (Hair, Black, Babin and Anderson, 2006).

Data analyses and administration

Statistical Package for the Social Sciences (SPSS) and AMOS was used as computer software in order to describe and analyse sets of quantitative data. The data generated was analysed using descriptive statistics of frequency and percentage. The instrument was administered to the respondents with the support of study assistants.

DATA ANALYSIS AND DISCUSSION

This study showed that through the development of the LSS model, steel manufacturing SMEs could improve their productivity rate. Therefore, the development of the LSS model goes beyond a mere manufacturing strategy for organisations. It is also aimed at accomplishing long-term competitive advantages in the manufacturing processes of SMEs and sustainability of business productivity upgrading. Evidence includes the improvement in steel manufacturing products processes, quality costs, increased sales, higher profits and better market penetration as well as increased knowledge for managers in the steel manufacturing SMEs who took part.

This section provides the information from the data analysed using descriptive statistics as statistical tool. Data is interpreted and indicated by the response below:

Characteristics of Sampled Steel Manufacturing SMEs

The study covered demographic profiles of both the managers or supervisors and the steel manufacturing SMEs. The managers or supervisors' profile comprised gender, age, years of business in operation, highest level of education, number of employees, whilst the information about manufacturing SMEs comprised geographical areas of Gauteng Steel Manufacturing (GSM) SMEs location and insight into the business systems.

Table 1: Gender in GSMSMEs according to the respondents

Gender		Frequency	Valid Percent
Valid	Male	148	81.8
	Female	33	18.2
	Total	181	100.0

Source: Field work 2016

From in Table 1, it was observed that 81.88% of the respondents were males while 18.2% were females' manager/supervisor in GSMSMEs. Coka (2014) states that the gender of SMEs has an influence or impact on steel manufacturing. These results also indicate that the industry is male dominated work which seems to be a general challenge filtering through South African steel manufacturing sector. Table 2 indicates that 4.4% of the respondents were aged between 18-25 years, 49 (27.1%) aged between 26 to 35 years and 37 (20.4%) aged 46 years and older.

Table 2: Age of manager/supervisor

Age of supervisor		Frequency	Valid Percent
Valid	18-25 years	8	4.4
	26-35 years	49	27.1
	36-45 years	87	48.1
	46 years or older	37	20.4
	Total	181	100.0

Source: Field work 2016

In terms of the age distribution of the respondents, Table 3 indicates that managers aged between 36 to 45 (48.1%) were mostly available in the job market and were making decisions regarding implementation of programmes to support productivity improvement in GSMSMEs. This is a natural situation, but the numbers of steel manufacturing managers or supervisors in SMEs between the ages of 26- 35 years are also increasing gradually, which may be due to more business exposure and to the fact that managers or supervisors tend to get older or retire.

Table 3: Years of business in operation

Years in business		Frequency	Valid Percent
Valid	0-1 years	1	.6
	2-5 years	38	21.0
	6-10 years	88	48.6
	Over 10 years	54	29.8
	Total	181	100.0

Source: Field work 2016

In terms of years of business in operation, the results in Table 3 indicate that 88 (48.6%) of respondents had been involved in the operation for 6-10 years, 54 (29.8%) for more than 10 years, 38 (21%) with 2-5 years in operation and lastly 1 (0.6%) of the total respondents were found to have been involved in the operation for one year or shorter. The inference that can be drawn is that 88 (48.6%) of respondents in GSMSMEs have been in operation for 6 to 10 years indicating stability in that level.

Table 4: Highest level of education of the respondents

Education		Frequency	Valid Percent
Valid	Below matric	8	4.4
	Matric	64	35.4
	Diploma/Degree	100	55.2
	Post graduate	9	5.0
	Total	181	100.0

Source: Field work 2016

Table 4 presents the level of education as a critical factor regarding knowledge, skills and training and understanding productivity enhancement in GSMSMEs. The highest number of respondents who were studying for or had received a diploma or degree were 100 (or 55.2%), followed by 64 (35.4%) with matric, and 8 (4.4%) below matric and only 9 (5%) at post-graduate level.

Table 5: Number of employees according to the respondents

Number of employees		Frequency	Valid Percent
Valid	6 – 50	116	64.1
	51-200	65	35.9
	Total	181	100.0

Source: Field work 2016

In terms of number of employees in a business, Table 5 shows that 116 (64.1%) of GSMSMEs that participated employed between 6-50 employees, implying the smallest SMEs are the biggest employers followed by medium-sized enterprises 65 (35.9%) employing between 51 and 200 employees. This illustrates the importance of small business as the biggest employer in the South African market.

Table 6: Geographical areas for GSMSMEs location

Geographic area		Frequency	Valid Percent
Valid	Tshwane/ Pretoria	50	27.6
	Ekurhuleni	57	31.5
	Johannesburg	25	13.8
	West Rand	23	12.7
	Sedibeng\Vaal	25	13.8
	Total	181	100.0

Source: Field work 2016

In terms of the geographical location of GSMSMEs, Table 6 indicates that most GSMSMEs who participated are located in Ekurhuleni 57 (31.5%) and Tshwane 50 (27.6%), whilst Johannesburg and Sedibeng account for 25 (13.8%) and 23 (12.7%) of industrial areas in the Westrand, signifying that Gauteng is the economic hub of the area.

Reliability analysis

Reliability analysis was conducted on questionnaire subscales. Leedy and Ormrod (2014:93) describe reliability as the consistency with which a measuring instrument yields a specific result when the entity measured has not changed. Pallant (2010:97) describes a Cronbach's alpha coefficient of more than 0.7 as signifying reliability and internal consistency. The reliability analysis of these latent factors was tested with Cronbach's alpha coefficient. As indicated in Table 7, the results were:

Table 7: Reliability analysis for the dependent variables

Construct	Cronbach's Alpha
Materials productivity	0.890
Financial productivity	0.916
Labour productivity	0.895
Total of all items used in the measurement model	0.935

The three (3) coefficients extracted under the productivity scale had acceptable alpha values of 0.890; 0.916 and 0.895 respectively, thereby indicating sufficient reliability on the three coefficients. This means there is a strong relationship between the variables used in steel manufacturing SMEs, since the Cronbach is less than 70 which is advantageous.

Table 8: Reliability analysis on input resource factors

Construct	Cronbach's Alpha
Humans capital	0.930
Technology management	0.913
Machinery	0.896
Competitiveness	0.896
Layout management	0.887
Finance	0.879
Government support	0.835
Location	0.828
Total of all items used in the measurement model	0.961

Exploratory Factory Analysis (EFA)

Pallant (2010) explains the purpose of exploratory factor analysis as data screening to reduce a data set to smaller variables and to establish interrelationships between a set of variables. A principle components analysis (PCA) was carried out in order to establish construct validity. The PCA was also done to determine the factors that alter productivity rates in steel product manufacturing SMEs in Gauteng. Prior to conducting the principle components analysis (PCA), an exploratory factor analysis (EFA) was conducted by means of two statistical measures generated by IBM SPSS, namely the Bartlett test of sphericity (Bartlett, 1954) and Kaiser-Meyer-Olkin (KMO) measures of sampling adequacy (MSA) (Kaiser 1970, 1974). KMO represents individual and multiple variables of squared correlation between variables and the value close to 1 indicates the shape of the correlation, and analysis yields distinct and reliable factors (Field, 2013). For the Bartlett test of sphericity to be significant or factor analysis to be considered appropriate, its p-value should be less than 0.05. The Kaiser-Meyer-Olkin (KMO) index value ranges from 0-1 and a value of 0.6 or above is suggested as a minimum for good factor analysis (Tabachnic & Fidell, 2007).

Total variance explained was also considered for this study in order to assess the variance for each factor explained. The threshold (60%) cumulative variance is quite commonly used in social sciences to establish satisfaction with the solution (Hair *et al.*, 1995). The retention of factors was decided using the Kaiser's eigenvalue of greater than 1 criterion. This rule specifies that all factors with eigenvalues of one and above are retained in the solution. A minimum factor loading of 0.5 was used for the loading to be considered significant (Hair *et al.*, 2014). Two separate exploratory factor analyses were conducted on the productivity scale and indicators of productivity (input resource factors). Chi-square provides a statistical test for its significance and basis for goodness of fit measure (Hair *et al.*, 2014).

Table 8: Exploratory factor analysis for the productivity scale

	Factor loading	Eigenvalue	Variance explained %
<i>Materials productivity factor</i>			
1. Materials produced	0.835	6.757	61.425
2. Machine hours	0.791		
3. Man hours	0.776		
4. Materials cost	0.717		
<i>Financial productivity factor</i>			

1. Utilisation	0.847	1.274	11.579
2. Market share	0.847		
3. Efficiency	0.845		
4. Profitability	0.629		

Labour productivity factor

1. Return on investment	0.840	1.012	9.198
2. Turnover	0.819		
3. Labour cost	0.678		

Notes: Kaiser-Meyer-Olkin =0.904

Total variance explained	82.202
---------------------------------	---------------

Table 10 shows the factor loadings, eigenvalue and percentages of variance and cumulative percentages of variance of the factors for the productivity scale. As shown in Table 9, three factors were extracted from the first exploratory factor analysis conducted on the productivity scale. The first item was labelled *materials productivity* as it grouped items relating to production of material. The second factor grouped items on financial production. Hence, it was called *financial productivity*. The third factor was entitled *labour productivity* as it grouped items regarding labour. The three factor solution accounted for 82.202% of the total variance, exceeding the 60% threshold (Hair *et al*, 1995). Factor one indicated 61.425 percent of the total variance with an eigenvalue of 6.757; factor two indicated 11.579% of the total variance with an eigenvalue of 1.274 and finally, the last factor explained 9.198% of the total variance with an eigenvalue of 1.012. Factor loadings shown in Table 9 are all above 0.5 indicating that the items are of utmost significance to the factors they are loading onto.

Table 10: KMO and Bartlett’s test

KMO and Bartlett’s test			
Kaiser-Meyer-Olkin measure of sampling adequacy		0.904	
Bartlett’s test of sphericity	Approx. X^2		1742.341
	df		55
	Sig.		.000

The productivity scale Kaiser-Meyer-Olkin (KMO) Measure of Sampling Adequacy (MSA) was 0.904, signifying that the data was appropriate for principal component analysis. Similarly, Bartlett's Test p value = 0.000 than 0.05, signifying sufficient correlation between items to proceed with EFA (as depicted in Table 9). Based on the exploratory factor analysis on input resource factors, DMAIC phases and LSS, the following LSS Model for Steel Manufacturing SMEs was developed to improve productivity level.

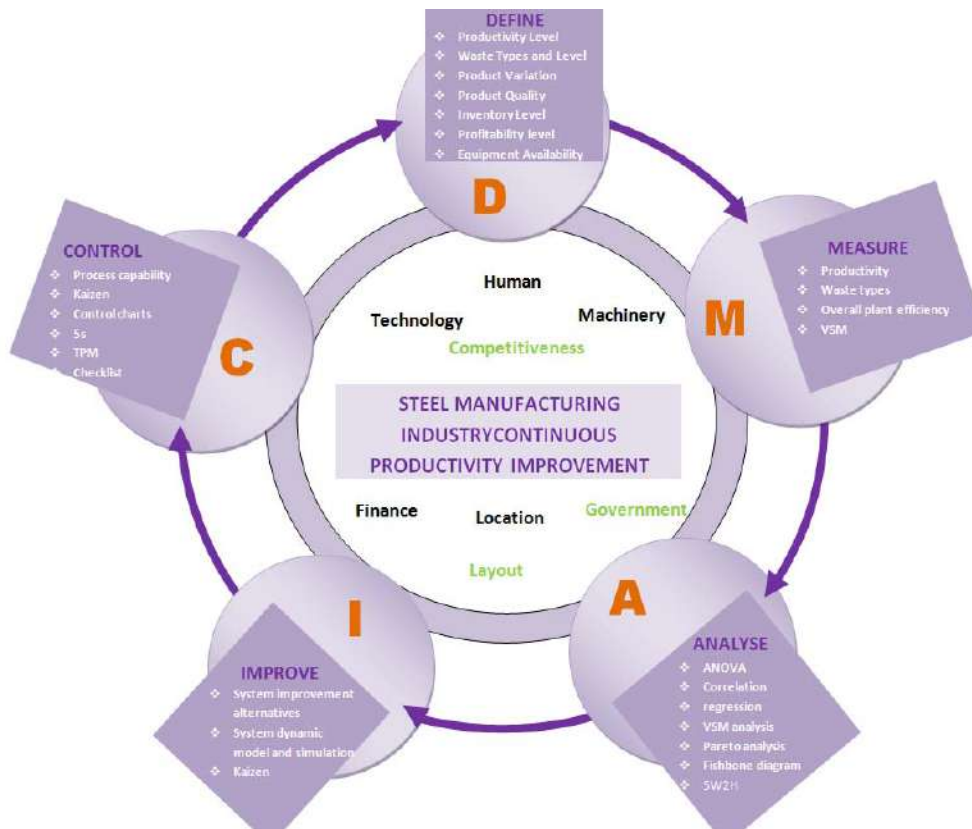

Figure 1: Lean Six Sigma Model for Steel Manufacturing SMEs (Source: Authors)

The LSS DMAIC model in this paper consists of eleven (11) elements divided into two sets, the first being LSS elements (define, measure, analyse, improve & control) and the second consisting of human, machinery, technology, competitiveness, finance, location, layout and government elements. (See Figure 1.) In recent years, much research has been conducted on the critical success factors of LSS in large manufacturing organisations. Figure 1 demonstrates a holistic LSS model that could be used to improve productivity in steel manufacturing SMEs.

CONCLUSIONS

This study contributed immensely to the development of steel manufacturing SMEs in improving productivity and efficient delivery of the organisation, and yielded findings and recommendations. The literature review presented numerous ground systems within the field of SME manufacturing process, and a Lean Six Sigma model for productivity improvement, human skills and knowledge, finance, location, machinery, technology, competitiveness, government and layout. The most significant findings of this study indicate that the main difficulties faced by managers or supervisors in the steel manufacturing SMEs are lack of consistent measurement of income per cost of employees, lack of knowledge, lack of training in LSS, low productivity rate, absence of the latest technology, lack of commitment from management, lack of government support, and poor utilisation of machines as a result of breakdowns and unskilled employees and poor operating procedures., preventing them to improve their productivity rate and manufacturing processes, as well as timely delivery to the customers. These and others are the main difficulties preventing managers or supervisors of steel manufacturing SMEs to enhance their standard procedures by adding value activities ensuring consistency in steel manufacturing SMEs in South Africa. The findings of this study have also examined productivity improvement models from other researchers. In future study, there is a need

to develop technology by a means of software that will be utilised integrate input factors with a parallel tools such as Value Stream Mapping, Cause-and-effect diagram, Just-in-time (JIT) and Total Preventative Maintenance (TPM) which be able to detect, distinguish and map the severity and extent of identifying bottleneck or waste as well as reducing the product variations to bare minimum in the steel manufacturing industry. This system will be faster and more accurate than using traditional methods. However, the findings of this study could be useful to steel manufacturing managers responsible for demonstrating the cost effective techniques in sub-Saharan Africa. For instance, the understanding of application of LSS model and the ability identify, assess and improve productivity level is key to gain competitive advantage and steel manufacturing SME managers deal with challenges associated with low productivity. A holistic Lean Six Sigma model of SMEs to improve productivity rate, reduce waste and overproduction in the steel manufacturing industry as well as difficulties faced by managers or supervisors in South Africa have been clearly investigated and identified, discussed in detail, and suggestions or recommendations regarding these impacts and difficulties were also discussed.

RECOMMENDATIONS

Steel manufacturing industries are highly regarded when addressing the difficulties in creation of employment in cities, towns or even rural areas of South Africa. They are mostly concerned with improving human capital, advanced technology and effective and efficient layout in the organisation, increasing competitiveness, and growing economies in creative and innovative ways. The government should increase its efforts to support SMEs in steel manufacturing to apply a LSS model and input resource factors, which encourages development. Firstly, LSS training programmes for both managers and employees, including the SME owner, need to be arranged by management. Secondly, the research advises that the dilemma of these value-adding activities be addressed by ensuring that there is management support and commitment, quality, delivery, reliability and flexibility. Productivity of these SMEs will be enhanced by introducing training on yellow belt and green belt level to employees for LSS tools awareness and identification of risk factors such as waste and defects; black belt level for supervisors in identifying problems and resolving solution waste reduction and master belt for owners or managers for implementing and monitoring LSS tools,. When productivity is enhanced in these SMEs for competitiveness, GDP improves in the country and development of the economy in the country prevails.

Based on the factors addressed which negatively influence productivity of steel manufacturing SMEs, the study recommends that if employees are motivated through skills, knowledge, training, innovation, responsibilities and accountability, they will have the ability to make decisions to the benefit of these SMEs. Further, with regard to government failure to support SMEs, the study endorses that owners take the initiative to approach government agencies put in place, such as SEDA and Productivity SA, for relevant information benefiting their businesses. Future research should also focus on assessing the impact of technology, development of LSS model related to other manufacturing industries such as food and beverages as well as textiles and clothing. Availability of the latest technology tools used in LSS such as Just-in-time (JIT), Total quality management (TQM), Total Preventative Maintenance (TPM), Material Requirements Planning (MRP), Statistical Process Control (SPC), Kaizen and process capability will facilitate and accelerate the manufacturing process for improved operational performance in SMEs. These tools can be effectively used if GSMSMEs collaborate with both government agencies and academics in the form of conferences, workshops and seminars, including experiential training of students during their final year as well as senior students.

Acknowledgements

We acknowledge the support by the Directorate: Research & Innovation Fund of the Tshwane University of Technology (TUT), Office of the Dean: Faculty of Management Sciences at TUT, Faculty of Engineering of Engineering & the Built Environment (Johannesburg of Johannesburg).

REFERENCES

- Akbulut-Bailey, A.Y., Motwani, J. & Smedley, E.M. (2012). When Lean and Six Sigma converge: a case study of a successful implementation of Lean Six Sigma at an aerospace company. *International Journal of Technology Management*, 57(1/2/3):18-32.
- AL-Najem, M., Dhakal, H., Labib, A. & Bennett, N. (2013). Lean readiness level within Kuwaiti manufacturing industries. *International Journal of Lean Six Sigma*, 4(3):280-320.
- Assarlind, M., Gremyr, I. & Backman, K. (2013). Multi-faceted view on a Lean Six Sigma application. *International Journal of Quality and Reliability Management*, 30(4):387-402.
- Belay, A.M., Helo, P., Takala, J. & Welo, T. (2014). Considering BPR and CE for faster product delivery: a case study in manufacturing firms. *International Journal of Productivity and Quality Management*, 13(3):349-375.
- Belekoukias, I., Garza-Reyes, J.A. & Kumar, V. (2014). The impact of Lean methods and tools on the operational performance of manufacturing organisations. *International Journal of Production Research*, 52(18):5346–5366.
- Caskey, K.R. (2015). Competitive strategies for small manufacturers in high labor cost countries. *Competitiveness Review*, 25(1):25-49.
- Chay, T.F., Xu, Y., Tiwari, A. & Chay, F. (2015). Towards Lean transformation: the analysis of Lean. *Journal of Manufacturing Technology Management*, 26(7):1-38.
- Chiarini, A. (2011). Japanese total quality control, TQM, Deming's system of profound knowledge, BPR, Lean and Six Sigma. *International Journal of Lean Six Sigma*, 2(4):332-355.
- Coka, B. (2014). *Annual report 2013-2014*. Midrand, Republic of South Africa: Productivity SA.
- de Carvalho, M.M, Ho, L. & Pinto, S.H.B. (2014). The Six Sigma program: an empirical study of Brazilian companies. *Journal of Manufacturing Technology Management*, 25(5):602-630.
- De Mast, J. and Lokkerbol, J. (2012). An analysis of the six sigma DMAIC method from the perspective of problem solving. *International Journal of Production Economics*, 139: 604-614
- Desai, D.A., Kotadiya, P., Makwana, N. & Patel, S. (2015). Curbing variations in packaging process through Six Sigma way in a large-scale food-processing industry. *Journal of Industrial Engineering International*, 11:119-129.
- Fore, S. & Mbohwa, C. (2010). Cleaner production for environmental conscious manufacturing in the foundry industry. *Journal of Engineering, Design and Technology*, 8(3):314 - 333
- Garza-Reyes, J.A. (2015). Green lean and the need for Six Sigma. *International Journal of Lean Six Sigma*, 6(3):226-248.
- Ghaleb, A.A., El-Sharief, M.A. & El-Sebaie, M.G. (2015). An Application of Lean Six Sigma (LSS) in Small and Medium Enterprises (SMEs): Cement bags industry. *International Journal of Scientific & Engineering Research*, 6(5):1327-1333.
- Habidin, N.F. & Yusof, S.M. (2013). Critical success factors of Lean Six Sigma for the Malaysian automotive industry. *International Journal of Lean Six Sigma*, 4(1):60-82.
- Hair, J.F., Black, W.C., Babin, B.J., Anderson, R.E. and Tatham, R.L. (2014). *Multivariate Data Analysis*, Seven edition, Pearson/Prentice-Hall, Englewood Cliffs, NJ.
- Hamilton, B.H., Nickerson, J.A. & Owan, H. (2015). Diversity and Productivity in Production Teams. *In Advances in the Economic Analysis of Participatory and Labor-Managed Firms*, 13:99-138.
- Hedley, N. (2015). Down in the dump: the outlook of SA manufacturing sector is weak and unless structural reforms are made, deindustrialisation will continue. *Financial mail*, 9-15 April:18-20.

- Hessels, J. & Parker, S. (2013). Constraints, internationalization and growth: A cross-country analysis of European SMEs. *Journal of World Business*, 48:137-148.
- Hoerl, R.W. & Gardener, M.M. (2010). Lean Six Sigma, creativity, and innovation. *International Journal of Lean Six Sigma*, 1(1):30-38.
- ILO. 2015. World Employment and Social Outlook: Trends (2015). *International Labour Organization*, Available from: www.ilo.org/wcmsp5/groups/public/---dgreports/---dcomm/---publ/documents/publication/wcms_337069.pdf.
- Jagoda, K., Lonseth, R. & Lonseth, A. (2013). A bottom-up approach for productivity measurement and improvement. *International Journal of Productivity and Performance Management*, 62(4):387-406.
- Jayaraman, K., Kee, T.L. & Soh, K.L. (2012). The perceptions and perspectives of Lean Six Sigma (LSS) practitioners. *The TQM Journal*, 24(5):433-446.
- Jesus, A.R., Antony, J., Lepikson, H.A. & Cavalcante, C.A.M.T. (2015). Key observation from a survey about Six Sigma implementation in Brazil. *International Journal of Productivity and Performance Management*, 64(1):94-111
- Jirasukprasert, P., Garza-reyes, J.A., Kumar, V. & Lim, M.K. (2014). A Six Sigma and DMAIC application for the reduction of defects in a rubber gloves manufacturing process, *International Journal of Lean Six Sigma*, 5(1):2-21.
- Kasier, H. (1970). A second generation Little Jiffy. *Psychometrika*, 35, 401-15. (1974). An index of factorial simplicity. *Psychometrika*, 39, 31-6.
- Krajewski, L.J., Maholtra, M.K. & Ritzman, L.P. (2016). *Operations Management: Processes and Supply Chains*, 11th ed. UK, Harlow: Pearson.
- Kumar, S., Singh, B., Qadri, M.A., Kumar, Y.V.S. & Haleem, A. (2013). A framework for comparative evaluation of Lean performance of firms using fuzzy TOPSIS. *International Journal of Productivity and Quality Management*, 11(4):371-392.
- Laureani, A. & Antony, J. (2012). Standards for Lean Six Sigma certification. *International Journal of Productivity and Performance Management*, 61(1): 110-120.
- Leedy, P.D. & Ormrod, J.E. (2014). *Practical Research: Planning and Design* 10th ed. UK: Pearson.
- Manville, G., Greatbanks, R., Krishnasamy, R. & Parker, D.W. (2012). Critical success factors for Lean Six Sigma programmes: a view from middle management. *International Journal of Quality & Reliability Management*, 29(1):7-20.
- Marsillac, E & Roh, J.J. (2014). Connecting product design, process and supply chain decisions to strengthen global supply chain capabilities. *International Journal of Production Economics*, 147:317–329.
- Mathur, A., Mittal, M.L. & Dangayach, G.S. (2012). Improving productivity in Indian SMEs. *Production Planning & Control: The Management of Operations*, 23(10-11):754-768.
- Mutalemwa, D.K. (2015). Does globalisation impact SME development in Africa? *African Journal of Economic and Management Studies*, 6(2):164-182.
- Mohanraj, R., Sakthivel, M. & Vinodh, S. (2011). QFD integrated value stream mapping: an enabler of lean manufacturing. *International Journal of Productivity and Quality Management*, 7(4):501-522.
- OECD. (2013). OECD Economic Surveys South Africa: March 2013 Overview. [Online], www.oecd.org/eco/surveys/South%20Africa%202013%20Overview%20FINAL.pdf.

- Pallant, J. (2010). *SPSS survival manual: A step by step guide to data analysis using SPSS*. 4th edition, Open University Press: UK, McGraw-Hill Education.
- Parnell, J.A., Long, Z. & Lester, D. (2015). Competitive strategy, capabilities and uncertainty in small and medium sized enterprises (SMEs) in China and the United States. *Management Decision*, 53(2):402-431.
- Parris, A. (2013). Improving processes for good in East Africa. *The TQM Journal*, 25 (5): 458-472.
- Prashad, K.D., Jha, S.K. & Prakash, A. (2015). Quality, productivity and business performance in home based brassware manufacturing units. *International Journal of Productivity and Performance Management*, 64 (2): 270-287.
- Prashar, A. (2014). Adoption of Six Sigma DMAIC to reduce cost of poor quality. *International Journal of Productivity and Performance Management*, 63(1):103-126.
- Salah, S., Rahim, A. & Carretero, J.A. (2010). The integration of Six Sigma and Lean Management. *International Journal of Lean Six Sigma*, 1(3):249-274.
- Schwab, K. (2015). The Global Competitiveness Report 2014-2015: Insight report. *World Economic Forum (WEF)*, Available from: www3.weforum.org/docs/WEF_GlobalCompetitivenessReport_2014-15.pdf.
- SEIFSA. (2015). Outlook for steel and engineering sector 2016-2017, SEIFSA NEWS, November/December, 1-43.
- Sin, A.B., Zailani, S., Iranmanesh, M. & Ramayah, T. (2015). Structural equation modeling on knowledge creation in Six Sigma DMAIC project and its impact on organizational performance. *International Journal of Production Economics*, 168:105–117
- Snee, R.G. (2010). Lean Six Sigma- Getting better all the time. *International Journal of Lean Six Sigma*, 1(1):9-29
- Soda, S., Sachdeva, A. & Garg, R.K. (2015). GSCM: practices, trends and prospects in Indian context. *Journal of Manufacturing Technology Management*, 26(6):889-910.
- Srinivasan, K., Muthu, S., Devadasan, S.R. & Sugumaran, C. (2016). Enhancement of sigma level in the manufacturing of furnace nozzle through DMAIC approach of Six Sigma: a case study. *Production Planning & Control*, 1-13.
- Statistics SA. (2015). Quarterly Labour Force Survey: Quarter 2: 2015. Available at: <http://www.statssa.gov.za/publications/P0211/P02112ndQuarter2015.pdf>
- Tabachnic, B.G. & Fidell, L.S. (2007). *Using multivariate statistics*. 5th Ed. Boston.
- Teng, H.S.S. (2014). Qualitative productivity analysis: does a non-financial measurement model exist? *International Journal of Productivity and Performance Management*, 63(2):250-256.
- Vinodh, S., Selvaraj, T., Chintha, S.K. & Vimal, K.E.K. (2015). Development of value stream map for an Indian automotive components manufacturing organization. *Journal of Engineering Design and Technology*, 13(3):380-399.

THE “UBUNTU” ENTREPRENEURSHIP PARADIGM: EVIDENCE FROM SOUTH AFRICAN RURAL INDIGENOUS MICRO-ENTREPRENEURS

Nyasha Muswera, Richard Shambare & Liberty Maunzagona
University of Venda, South Africa

ABSTRACT

Given the dichotomy of entrepreneurship as being either opportunistic or survivalist; the extant literature endears towards the former. Opportunity entrepreneurship, it is believed, results in high firm growth, profit maximisation, and sustained economic prosperity. Consequently, many business ventures not pursuing high growth or profit maximisation are not only misidentified as survivalist; but are also depicted as less desirable to the economy and, thus, discouraged. Our view, however, is that this position is largely Western and overly quantitative; so much so that it ignores qualitative measures of entrepreneurial success. In this paper, we present evidence supporting that the ‘survivalist’ entrepreneur label, within the African context, is a misnomer. Furthermore, we postulate the existence of the Ubuntu entrepreneurship paradigm – an entrepreneurial philosophy that accounts for most of the variation not currently explained by the profit maximisation-survivalist dichotomy. To that effect, the aim of this article is threefold. First, to provide a conceptual definition of the Ubuntu entrepreneurship paradigm. Second, the article presents evidence confirming the existence of Ubuntu entrepreneurship. Third, several directions for continued research are discussed. The value of this article is that it is the first to acknowledge the existence of the Ubuntu entrepreneurship paradigm. In doing so, it emphasises the contribution of micro-entrepreneurs as well as presenting strategies for supporting these business ventures.

Keywords: Culture, entrepreneurship, micro-entrepreneurs, South Africa, Ubuntu

INTRODUCTION

The point of departure, in this paper, is presenting the complexities of conceptualising entrepreneurship. Questions such as ‘*What constitutes entrepreneurship?*’ and ‘*Who is an entrepreneur?*’ are dominant themes in contemporary entrepreneurship debates. For instance, in its publication, the *Community College Entrepreneurship*, the National Association for Community College Entrepreneurship (NACCE) (2010:6) dedicated the entire Spring/ Summer 2010 issue to “starting a dialogue on the meaning of the “E” in NACCE”. To this end, NACCE (2010) explains this enigma as follows:

Ask a roomful of NACCE members [or academics] to agree on a definition of entrepreneurship and you are bound to have a lively and lengthy discussion. But will this definition of entrepreneurship be the same one you’d get if you asked state legislators, business owners, program funders, or traditional and non-traditional college students to hold a similar discussion? Possibly not. And therein lies the challenge (NACCE, 2010:6).

To address the above-mentioned Table 1 below illustrates the evolution of entrepreneurship over the years.

Table 1: Entrepreneurship definition

Author (year)	Definition
Cantillon (1755)	Entrepreneur bears risks and plans, supervises organises and owns factors of production
Say (1803) (economist)	proposed that the profits of entrepreneurship were separate from profits of capital ownership
Schumpeter (1934) (economist)	Described entrepreneur as someone who is an innovator and someone who “creatively destructs”.
Drucker (1964) (management author)	Described the entrepreneur as someone who maximises opportunity.
(Reynolds, et al. 1999:3)	<i>“any attempt at new business or new venture creation, such as self-employment, a new business organisation or the expansion of an existing business, by an individual, a team of individuals, or an established business”.</i>

Entrepreneurship has been through major evolution over the years. Early theorists in attempting to define entrepreneurship placed emphasis on who is an entrepreneur? That is, the characteristics that distinguishes entrepreneurs from non-entrepreneurs. And also, on what are entrepreneurial roles? These include the efforts of an individual who goes against the odds, a “*lone ranger*” or “*maverick*”, who creatively destructs to invent something new (Schumpeter, 1934) as well as maximise opportunities (Drucker, 1964).

However, the majority of these definitions stem from a western-centric perspectives where success is measured in terms of materialistic economic gain and is characterised with high competitiveness (Saffu, 2003). Thus, an African perspective into business success factors is called for.

EVIDENCE OF THE EXISTENCE OF UBUNTU ENTREPRENEURSHIP

Small, medium, and micro enterprises (SMMEs) are the seedbed for indigenous entrepreneurship in Africa (Aryeetey & Ahene, 2005). In particular, micro enterprises (e.g., airtime and vegetable vendors) play an important role in economic development in emerging economies such as South Africa (Inan & Bititci, 2015:310). These businesses not only provide employment opportunities and income for households, they also provide revenue for government in the form of trading licences, rates, and taxes. Thus, at the local level, micro enterprises are drivers for local economic development. It is for this reason that developing countries such as South Africa consider it a national priority to promote micro-entrepreneurship (National Development Plan, 2012).

In South Africa, for instance, despite numerous government efforts (including the formation of the Ministry of Small Business Development) to leverage micro-entrepreneurship, very little is known about these businesses – how they operate and, more importantly, which factors influence their success. This is particularly important given that three out of four new SMMEs fail within the first two years of their inception (Department of Trade and Industry, 2015). Despite their high failure rate, some categories of SMMEs have shown a high propensity to survive well beyond the 24-month failure threshold. Informal fruit vendors, for instance, have been observed to operate very successful ventures that are profitable and sustainable.

More often than not, informal traders tend to be individuals with low education and literacy levels. Even more puzzling is the fact that these entrepreneurs do not have formal (written) business plans, as advocated by many entrepreneurship specialists, but operate thriving businesses. A case in point is the fruit and vegetable vendors at the Tshakuma Fruit Market in Limpopo; several traders at Tshakuma have been in business for more than 30 years. Closer inspection indicates that a multitude of micro-entrepreneurs violate several entrepreneurship traits (e.g., educated, need for achievement, self-centred) lauded as being imperatives for success. The generality of these

traders seems to apply the “Ubuntu” entrepreneurship paradigm – a set of non-conventional business strategies that include sharing stock with competitors, lending money to rivals, and operating a business without a business plan. Consequently, the case of these informal fruit and vegetable vendors, thus, leads us to ask the following three questions:

- 1) *How do these entrepreneurs, who seemingly lack all the desired qualities of entrepreneurs, run successful businesses?*
- 2) *Given that these traders sell virtually the same product line, they are in fact competitors; as such, how do they deal with competition? In other words, how do they attain competitive advantage – an imperative for business success?*
- 3) *Since entrepreneurs are considered to be “lone rangers” or “mavericks” (Schumpeter, 1934), how do micro-entrepreneurs in collectivist societies such as South Africa balance the supposedly individualistic nature of entrepreneurship and the collectivist demands of their social lives?*

Against this backdrop, the purpose of this paper is to conceptually explore and analyse how rural micro-entrepreneurs in a moderately collective culture (Hofstede, 1980) like South Africa, implement the integrative “Ubuntu” entrepreneurship paradigm for venture success and sustainability; and also, to redefine entrepreneurship critical success factors.

DEFINING UBUNTU ENTREPRENEURSHIP

African cultures are diverse but there are remarkable similarities, specifically the community-based definition of an individual which is one of the striking characteristics of the sub-Saharan Africa cultures (Mbiti, 1970). This is based on the understanding that we are truly human only in community with other persons. The word Ubuntu originates from the Nguni group of languages and has other cognates in other Bantu languages such as *abantu*, *botho*, *bunhu*, *munhu*, *umtu*, *utu* and *vhuntu*. The word Ubuntu is derived from a Nguni (isiZulu) aphorism: *Umuntu Ngumuntu Ngabantu*, which can be translated as “a person is a person because of or through others” (Fraser-Moloketi, 2009; Tutu, 2004). Ubuntu can be loosely translated in English as “humanness or being human.” In other words, Ubuntu is best described as:

... an African philosophy that seeks to promote harmonious relations and interaction among people. This philosophy suggests that a person can only truly and fully exist if he or she co-exists with others in his or her community. In other words, this means that one should always have a strong sense of consideration for others (Shambare, 2016:217).

In simplifying the Ubuntu concept, John Mbiti (1970) clearly stated that, “*I am because we are, and since we are, therefore I am.*” Yusufu Turaki (2001) reiterates and stated that, “People are not individuals living in a state of independence, but part of a community, living in relationships and interdependence”. Khoza (1994) described Ubuntu as a social contract beyond the nucleus family to extended kinship network, that is, the community. Mbigi (1995) coined the term “collective fingers theory” in reference to the Ubuntu philosophy and identified the following key social values: survival, solidarity, compassion, respect and dignity.

These core values have several associated values which are not only unique to Africa because the Ubuntu concept is rooted in human nature, which is common to the entire human race (Lutz, 2009). However, the communal character of the African culture does not entail that communality obliterates individuality. The ethics of a true Ubuntu community does not ask individuals to sacrifice their own good in order to promote the good of others; as is the case with Marxist collectivism (Lutz, 2009). But rather, individuals recognise that they can attain their own true good only by promoting the good of others.

SUCCESS FACTORS IN UBUNTU ENTREPRENEURSHIP

In southern Africa there seem to be other critical success factors different from the conventional entrepreneurship success factors in western entrepreneurship literature (Saffu, 2003). These factors can be traced to the Ubuntu or Unhu African philosophy. For theoretical precision the Ubuntu critical success factors listed in *Table 1* are discussed using Hofstede’s cultural dimension. The Hofstede dimensions were chosen for the following reasons:

- These cultural dimensions are the most frequently studied in the context of national culture and entrepreneurship (Hayton, George & Zahra, 2002);
- The measures used in formulating these dimensions were based on 53 developed and developing countries; and
- Other studies (Hoppe, 1990 and Sondergaard, 1994) replicated Hofstede’s survey and had similar results with significant correlations to Hofstede’s dimensions.

Table 2: Ubuntu Success Factors

Cultural dimension	Conventional success characteristic	Ubuntu success characteristic
Power distance	Low in power distance	<i>Respect</i> - Need for power wealth and status
Uncertainty avoidance	Low in uncertainty avoidance	<i>Solidarity</i> - Ability to use the community or family as a fortress against ambiguous situations
Individualism/Collectivism	High individualism	<i>Survival</i> - Ability to balance interests of the community and business
Masculinity/Femininity	High in masculinity	<i>Compassion</i> - More likely to succeed as a female, showing modesty and empathy

Source: Adapted from Saffu (2003)

a) Power-distance (PDI) vs respect

Power-distance is defined as the extent to which the less powerful members of the society or institution accept and expect that power is distributed unequally. A high PDI indicates hierarchies and inequalities (Mazonde & Carmichael, 2016). Most southern-African countries are hierarchal with the exception of South Africa (Thomas & Bendixen, 2000). A high PDI was found to be negatively related to entrepreneurial innovation (Shane, 1993). Kreiser, *et al.* (2010) in their study of entrepreneurial firms in Canada, Ireland, Belgium, Germany, Singapore, and China (PRC) concluded that power distance negatively influence proactive firm behaviours. Yeboah (2014) in a study of Ghanaian entrepreneurs found that power distance had a significant positive relationship with risk taking.

b) Uncertainty avoidance (UAI) vs solidarity

Uncertainty avoidance relates to how a society tolerates ambiguity, that is, “how culture programs its members in dealing with unstructured situations” (Hofstede, 2001). A high UAI reflects a low tolerance for risk, ambiguity and unpredictability which can be managed by defined set rules, which in turn is considered unfavourable for entrepreneurship (Mazonde & Carmichael, 2016). Shane (1993) observed that a high UAI was negatively related with national innovation for the periods 1975 and 1980. In South Africa Thomas and Bendixen (2000) revealed that white South African managers scored a lower uncertainty avoidance score than their black African counterparts.

c) Individualism-collectivism (I-C) vs solidarity/survival

Individualism-collectivism refers to the degree to which the individuals in a society are integrated into groups. In individualist cultures ties between individuals are loose, everyone is expected to look after himself/herself and one’s immediate family. Whereas, in a collectivist society ties within the in-group are strong, loyal collective

and cohesive (Mazonde & Carmichael, 2016). A collectivist culture is characterised by subordination of individual interests to that of the group interest when a need arises (Francis & Hezel 2009), in exchange for their loyalty and support (Thornton, Ribeiro-Soriano & Urbano, 2011). Shane (1993) concluded that individualism was associated with entrepreneurial innovation. On the other hand, Mazonde and Carmichael (2016) assert that in-group collectivism leads to increased entrepreneurial activity but only in countries with a low to medium growth domestic product (GDP). Yeboah (2014) found that individualism had a non-significant positive relationship with entrepreneurship risk taking.

d) Masculinity-femininity (MAF) vs compassion

Masculinity-femininity is associated with the distribution of values between genders. Masculinity stands for a belief in materialism and decisiveness rather than service and intuition (Thornton, Ribeiro-Soriano & Urbano, 2011). Masculine societies are characterised by being assertive, willingness to confront and competitive whereas, feminine societies are characterised by being modest and caring. Shane (1993) found no significant association between MAF and entrepreneurial innovation.

SUMMARY AND CONCLUSION

A review of existing literature indicates inconsistencies and diverse determinants of entrepreneurship. Additionally, the majority of research concentrate on one-dimensional determinants of entrepreneurship. Consequently, no precise integrative framework for micro-entrepreneurship in rural areas of developing countries exist. However, a meticulous review of determinants from other indigenous societies reveal a set of critical success factors crucial for the entrepreneurship process. These critical factors are not universal but are specific for rural indigenous communities in developing countries, and are deeply embedded in culture. In conclusion, we posit that it would be highly beneficial if all stakeholders- government, rural entrepreneurs and scholars in the entrepreneurship field would work interactively to embrace the idea of cultural context when formulating policies, strategies and theoretical frameworks to determine entrepreneurial success.

This conceptual paper attempted to uncover the palpable gap in entrepreneurship literature that suggests that there exist a universal set of critical success factors which enhances entrepreneurial activity and venture success. However, as illustrated in this paper, venture success characteristics are contextual and an entrepreneurship model to this effect has to be developed. Empirical studies on this topic from various African countries and other parts of the world with similar socio-cultural and economic backgrounds should be conducted; in an attempt to further explore other critical success factors for increased entrepreneurial activity in the various regions of the world.

REFERENCES

- Aryeetey, E., & Ahene A. A. (2005). *Changing Regulatory Environment for Small-Medium Size Enterprises and their Performance in Ghana*. Centre on regulation and competition working paper series, paper no.103
- Cantillon, P. (1755). *Essai sur la nature du commerce en général*. 1st ed. Londres [Paris].
- Department Of Trade and Industry. (2015). *The Department Of Trade and Industry Annual Report 2014-2015*. Available at: <<http://www.thedti.gov.za/downloadfileaction?id=1043>> [Accessed 2 June 2016].
- Fraser-Moleketi, G. (2009). *Towards A Common Understanding of Corruption in Africa*. Public Policy and Administration, 24(3), pp.331-338.
- Drucker, P.F. (1964). *Managing for Results: Economic Task and Risk-taking Decisions*. Harper & Row, New York, NY.
- Francis, X and Hezel, S.J., 2009. The Role of Culture in Economic Development. *Micronesian Counselor*, 77, 11–19.
- Hayton, J.C., George, G. and Zahra, S.A., 2002. National Culture and Entrepreneurship: A Review of Behavioral Research. *Entrepreneurship Theory and Practice*, 26 (4), 33-52.
- Hofstede, G. (1980). *Culture's Consequences, International Differences in Work-Related Values*. Beverly Hills: Sage.
- Inan, G. and Bititci, U. (2015). *Understanding Organizational Capabilities and Dynamic Capabilities in the Context of Micro Enterprises: A Research Agenda*. Procedia - Social and Behavioral Sciences, 210, pp.310-319.
- Khoza, R. (1994). *African Humanism*. Ekhaya Promotions: Diepkloof Extension SA.
- Kreiser, P., Marino, L., Dickson, P. and Weaver, K. (2010). Cultural Influences on Entrepreneurial Orientation: The Impact of National Culture on Risk Taking and Proactiveness in SMEs. *Entrepreneurship Theory and Practice*, 34(5), pp.959-983.
- Lutz, D. (2009). *African Ubuntu Philosophy and Global Management*. Journal of Business Ethics, 84(3), pp.313-328.
- Mazonde, N. and Carmichael, T. (2016). The influence of culture on female entrepreneurs in Zimbabwe. *The Southern African Journal of Entrepreneurship and Small Business Management*, 8(1).
- Mbigi, L. (1995). *Ubuntu: A Rainbow Celebration of Cultural Diversity*. Pretoria: Ubuntu School of Philosophy.
- Mbiti, J. (1970). *Christianity and Traditional Religions in Africa*. International Review of Mission, 59 (236), pp.430-440.
- Mueller, S. and Thomas, A. (2000). Culture and Entrepreneurial Potential: A Nine Country Study of Locus of Control and Innovativeness. *Journal of Business Venturing*, (16), pp.51-75.
- Reynolds, P. (1999). *Creative Destruction: Source or Symptom of Economic Growth?* In: Hechavarria, D.M. and Reynolds, P.D. (2009). Cultural Norms & Business Start-Ups: The Impact of National Values on Opportunity and Necessity Entrepreneurs. *International Entrepreneurship and Management Journal*, 5(4), pp.417–437.

Say, J.B. (1803). *Traité d'économie politique: ou, simple exposition de la manière dont se forment, se distribuent et se consomment les richesses*, Translation: *Treatise on Political Economy: On the Production, Distribution and Consumption of Wealth*, Kelley, New York: 1964 (1st edition: 1827).

Saffu, K. (2003). *The Role and Impact of Culture on South Pacific Island Entrepreneurs*. *International Journal of Entrepreneurial Behavior & Research*, 9(2), pp.55-73.

Schumpeter, J. (1934). *The Theory of Economic Development*. Cambridge, MA: Harvard University Press.
Shane, S., 1993. Cultural Influences on National Rates of Innovation. *Journal of Business Venturing*, 8(1), 59–73.

The National Association for Community College Entrepreneurship. (2010). *Defining Entrepreneurship- Starting a Dialogue on the Meaning of the “E” in NACCE*. *Community College Entrepreneurship*, [Online] (Spring/Summer). Available at: http://c.ymcdn.com/sites/www.nacce.com/resource/resmgr/journals/spring_summer_2010.pdf [Accessed 12 May 2017].

Thomas, A. and Bendixen, M. (2000). The Management Implications of Ethnicity in South Africa. *Journal of International Business Studies*, 31(3), pp.507-519.

Thornton, P., Ribeiro-Soriano, D. and Urbano, D. (2011). Socio-cultural factors and entrepreneurial activity. *International Small Business Journal*, 29(2), pp.105-118.

National Development Plan (2012). *Our Future-Make It Work: National Development Plan 2030*. [Online] Available at: <http://www.info.gov.za/issues/national-development-plan-2012> [Accessed 12 May 2017].

Turaki, Y. (2001). *Is Democracy The Ideal Universal Political System?* *Philosophia Reformata*, 66(1), pp.132-138.

Tutu, D. (2004). *God Has A Dream: A Vision Of Hope For Our Time*. London: Rider & Co.

Yeboah, M. (2014). Analysis of Entrepreneurship: How does Culture Influence Risk-Taking in SMEs in the Sekondi-Takoradi Metropolis, Ghana? *American International Journal of Contemporary Research*, 4(2), pp.131-140.

THE STATE OF PERFORMANCE MANAGEMENT AND DEVELOPMENT SYSTEM IN THE SELECTED SOUTH AFRICAN NATIONAL GOVERNMENT DEPARTMENTS

Makamu N.I
North-West University, South Africa

ABSTRACT

South African national government departments (SANGD) are faced with an immense challenge in implementing the current performance management and development system (PMDS). Currently the PMDS is the only instrument in place used to manage employee's performance in the SANGD. Poor management and implementation of the system can have a huge negative effect on the organisational performance as employees performance can easily be affected by these factors. The paper aimed at assessing the current state of the performance management and development system in the selected SANGD. Qualitative approach was adopted and interviews were used as a primary data collection tool.

Keywords: Performance management, Training and Development, Human Resource Management, Performance appraisal and Public service.

INTRODUCTION

The South African government is the largest employer and the main provider of the public service in the country, therefore acceptable performance from public servant is expected. Poor management and implementation of the performance management and development system by the departments might affect the performance of employees which can eventually have a negative impact on the overall performance of the organisation, and consequently results in the public not receiving services as expected which can triggers public protest. In South Africa it is evident that most public protests occur because of poor service delivery (Beardwell & Claydon 2010, p. 481). Performance management and development system requires a continuous monitoring and assessment in order to track whether it is addressing the purpose it was developed for and if not it can be adjusted accordingly. The study focuses on five selected national government departments in South Africa. The departments include: Department of Public Service and Administration (DPSA), Department of Planning Monitoring and Evaluation (DPME), National Department of Tourism (NDT), Department of Arts and Culture (DAC), and Office of the Public Service Commission (PSC). A qualitative approach was adopted in the study. Interviews were used as primary data collection tool and thematic analysis was used to analyse primary data from respondents.

PERFORMANCE MANAGEMENT SYSTEM IN ORGANISATIONS

Most organisations around the world if not all have adopted performance management system to manage the performance of their employees and of the organisation as a whole. It is however sad to note that having performance management system in an organisation does not necessarily translate to effective employees performance improvement, thus, more work is still left to supervisors and managers to ensure that the system is implemented effectively to enable the objective of the system to be achieved. In this paper, performance management as defined by Jackson, Schuler and Werner (2009) is a formatted, structured process used to measure,

evaluate, and influence employees' job related attitude, behaviour, and performance results"(p. 314). Adoption of performance management system is an important component of management reform in the public sector and has become more prevalent in the last two decades (Akbar, Pilcher and Perrin, 2012, p.264).

Managing employees performance in an organisation has always been regarded a challenge of human resource management where employees frequently complain about the system or strategies used by managers to manage, measure and evaluate performance. Performance management, as an areas of human resource management has been identified as one of the areas that need more attention. A holistic approach to performance management process include the following: performance planning, performance coaching and mentoring, performance measurement, performance feedback and documentation, performance evaluation and appraisal (PSC, 2014, p. 8). For several decades, performance measurement has been used as an internal informational tool to evaluate departmental operations and make program and budget decision (Ho and Ni, 2005) in (Adams, Muir & Hogue, 2014, p. 46). The implementation of information systems for performance management provides opportunity to incorporate measures aligned with sustainability outcomes and provide reportable indicators. Additionally, the role of information produced by the performance measurement system in promoting organisational effectiveness is an issue that has attracted particular attention not only in Australia, but also overseas (Hood, 1995; Guthrie et al., 1999) in (Adams, Muir and Hoque, 2014, p. 48).

They further argued that in recent years there has been increasing global pressure on all levels of governments to improve performance. With reference to the United Kingdom (UK), performance management has been affected by several factors, including an emphasis on cost effectiveness and the developmental purpose of performance management. Performance management in UK is an established organisational practice and is clearly influenced by broader societal issue as socio economic, political, and legal trends, while Turkey performance management system is fairly novel, but almost 80% of firms are using the same type of system because personal relationships play an important role in Turkish culture. An important challenge is the implementation of a system that ensures valid, reliable, and fair performance measurement (Aguinis, 2013, p. 24-25). From a statistical perspective for both the 2012/2013 and 2013/14 financial years, Performance Management in South Africa was the leading cause of grievances amongst employees in the Public Service.

Overall implementation of the performance management and development system (PMDS) policy in itself seems to create an unreasonable expectation in that the tool is used more for monetary gain than development-orientation and addressing poor performance. It was also emphasised that the poor implementation of the PMDS policy framework by line managers, but not the tool itself, could be a possible reason for dissatisfaction by employees (PSC, 2014, p. 1). The systems of performance measurement have become more sophisticated and widespread in the last three decades. However, despite the long period of implementation and refinement, fundamental weaknesses persist in the quality and use of performance information (Hawke, 2012, p. 310). A performance measurement system's coordinating role is to direct and focus the attention of decision makers on results and determinants or primary and secondary roles (Atkinson *et al.*, 1997; Fitzgerald *et al.*, 1991; Kaplan and Norton, 1992, 1996) in (Kloot & Martin, 2000, p. 234). Increasingly, performance measurement is considered to be a vital tool for local government to not only measure its activities, but also to provide feedback into the management process to help improve future performance (LOGOTRI, 2003) in Akbar, Pilcher and Perrin (2012, p. 264). Employees in the public sector continues to criticise the performance management system because of the way it is managed and implemented by the supervisors and managers.

OBJECTIVES OF PERFORMANCE MANAGEMENT SYSTEM

Performance management is concerned with three major objectives. The first one is to improve performance in order to achieve organisational, team and individual effectiveness. The second one is concerned with development, for performance improvement is not achievable unless there are effective processes of continuous development. The third objective is concerned with the satisfying needs and expectations of all the organisation's stakeholders, management, employees, customers and the general public. In all these three undertakings, performance management relies on communication and involvement, and creating a climate in which continuing dialogue between managers and members of their teams takes place to define expectations and share information on the organisation's mission values and objectives (Armstrong, 2006, p. 143).

A key factor in the success of any organisation is its ability to ensure that everyone clearly understands what they are required to do in order to contribute to its success. SMART is an acronym used to describe key characteristics of appraisal objectives (Banfield & Kay, 2012, p. 300). Performance management begins with setting goals. Goals define the results that people should aim to achieve. Setting goals is one of the essential functions of management (Harvard Business School, 2006, p. 2). Thus a smart principle must be followed when setting whatever objective the organisation needs to achieve. The SMART acronym implies the following specificities of the term: Simple, Measurable, Achievable, Relevant, and Time frame.

BARRIERS IN IMPLEMENTING PERFORMANCE MANAGEMENT SYSTEM IN ORGANISATIONS

Managing employee's performance is a challenging task which requires commitment from both supervisors and managers. Managing performance is about raising performance not rating performance; it is a continuous process and not an annual event (Armstrong, 1998, p. 141). It is scientifically proven that most employees do not like to be managed as it involves to be assessed at a certain time, while on the other hand some managers and supervisor do not support the system as they consider it time consuming. According to Christensen (2006) and Ivancevich (1998), maintain that managing employee's performance comes with a big challenge (p.141 & p. 263). Cascio and Aguinis (2005), argues that the main three primary barriers to effective implementation of performance management system include: political, organisational and interpersonal barriers' (p. 85 -100).

Organisational barriers results when workers are held responsible for errors that may be the result of built-in organisational structure. Deming (1986) in Cascio and Aguinis (2005) states that variation in performance within system may be due to common causes or special cause common, causes are faults that are built into the system due to prior decision, defects in materials, flaws in the design of the system, or some other managerial shortcoming. Special cause are those attributes to a particular event, a particular operator, or a subgroup' (p. 85).

Political barrier stem from deliberate attempts by raters to enhance or to protect their self-interest when conflicting course action are possible. Vigoda (2000), quoted by Cascio & Aguinis (2005), state that appraisal takes place in an organisational environment that is anything but completely rational, straight forward, or dispassionate. They furthermore stress that achieving accuracy in appraisal is less important to managers than motivating and rewarding their subordinate' (p.87).

Lastly, **Interpersonal barrier** arises from the actual face to face encounter between subordinate and supervisors. It may also hinder the performance management process, because of a lack of communication, employees may think they are being judged according to one set of standards when their supervisor actually use different one.

PERFORMANCE MANAGEMENT SYSTEM LEGAL FRAMEWORK

It is worth noting that the South African government performance management system is governed by different number of legislations which helps ensure that formal and effective adherence of the system is maintained. Some of the key legislations include:

The Public Service Act 103 of 1994

Section 3 (5) (c) of the Public Service Act 103 of 1994, indicate that performance appraisal should be provided for in the public service. Section 7 (3) (b) of the above mentioned Act stipulate that an HOD shall be responsible for the effective management and administration of his or her department.

The Public Service Regulation of 2001

Part VIII, paragraph B1 of the Public Service Regulation of 2001 and section 1,5 of the SMS public service handbook (Republic of South Africa 2003) provides that public service institutions shall determine different systems for performance appraisal for HOD's, Senior managers and all the staff.

White paper on Human Resource Management in the Public service of 1997

According to Section 5.9.1 of the White paper on human resource Management in the Public service of 1997 states that the success of the Public Service in delivering its operational and developmental goals depends primarily on the efficiency and effectiveness with which employees carry out their duties. Furthermore, it states that performance is therefore an integral part of an effective human resource management and development strategy. It is an on-going process, in which the employee and employer together, strive constantly to improve the employee's individual performance and his or her contribution to the organisation's wider objectives.

Public Service Coordinating Bargaining Council Resolution no 13 of 1998

This resolution provides for a framework for senior managers in the public service to agree upon individual performance, which are: Key duties and responsibilities, outputs targets for the performance agreement period, date for performance reviews, dispute resolution mechanisms, and date on which salary increment will come into effect and mechanism for the managing/awarding salary increases.

Public Service Coordinating Bargaining Council Resolution No. 9 of 2000

This resolution provides for the structuring of remuneration packages to be translated to more transparent total cost to employer and inclusive flexible remuneration package system.

Public Service Coordinating Bargaining Council Resolution no 10 of 1999

Paragraph 4 of the resolution outlines procedures in respect of poor performance. It provides clear steps in managing employees who perform poorly.

Senior Management Service Handbook, 2003, as amended

Chapter 4 of the handbook describes the processes and requirements of performance management and development for members of the SMS. Part III provides that the Minister of Public Service Administration may issue directives on PM for senior managers. It further recommends that departments must establish their own departmental PMDS policy and must integrate the provisions of Chapter 4 of the SMS handbook in their departmental policy on PMDS and ensure that there are linkages between the performance measures that apply to SMS members and non-management employees.

- Relevant directives issued by the Department of Public Service Administration and departmental policies.

RESEARCH METHODOLOGY

Research design is the arrangement of procedures for collection and analysis of data in a manner that aims to combine relevance to the study purpose with economy in procedure (Mouton & Marais, 1996, p.32). A qualitative approach was adopted in this study. Primary data was collected by means of using interviews. In-depth-interviews

were conducted with the middle management services (MMS), senior management services (SMS), union representative and those units responsible for implementing the system in the five selected national government departments. Secondary data was collected by means of consulting relevant literature such as published reports, articles and books. Brynard & Hanekom (2006), assert that data which exist and has already been used by other researchers is regarded as secondary' (p. 36).

The departments include: NDT, PSC, DPME, DPSA and DAC. A purposive sampling was adopted to sample these departments. DPSA, OPC, DPME were sampled as the researcher was of the view that they are the Departments responsible for the development, implementation, Monitoring and Evaluation of the system in the South African national government departments, while the other two Departments, DAC and NDT were sampled in order for the researcher to assess whether the other three department are impacting positively on the implementation of the system as purposed. Data collected by interviews are very useful in situation where more knowledge is required. This flexibility allowed the interviewer extended opportunities to ask of a respondent varied questions on their perceptions and this was an asset as it elicited extremely rich information (Kumar, 2005, p.125). The primary collected data was analysed by means of using thematic analysis. This paper thus draws from primary data.

FINDINGS AND RESULTS DISCUSSION

The current public service performance management and development system is under a serious scrutiny in South Africa. The study revealed that employees state that the performance management and development system is not fully effective, and there are challenges which need to be addressed in order for the system to be fully effective. The results revealed that employees are demotivated to perform optimally due to the challenges they currently experience resulting from the system. Employees has lost trust and confidence on the current system because it create room for discrimination by managers and supervisors. The study record that the fact that the system is used as a compliance tool rather than a management tool is one of the worrying factor in these departments. It further revealed that some managers and supervisors are biased when assessing their employees and some are unprofessional making it more difficult to adhere to the processes of the policy. The complaints and grievances pertaining to the system take long to resolves which is another worrying factor for most employees in the South African public service. The performance management and development system in these departments are not only used for the purpose of managing employees performance but rather perceived as a money making tool (reward system).

Managing employee's performance in organisations has been a challenge for centuries. It is scientifically proven that employees can only improve their performance if there is something for them on the other side which makes it more challenging for most unskilled managers to encourage their subordinates to improve their performance by using the performance management and development system. There are many factors which can demotivate employees to improve their performance. The results revealed that lack of budget is another cause of these challenges, employees personal development plan listed in their performance agreement are not addressed with reasons of lack of budget in these departments. Again, changing of scores by moderating committee demotivates employees to perform optimally. Thirdly, lack of experts and committed managers at these departments is another factor which demotivates employees to improve on their performance: Experts and committed managers responsible to ensure that their subordinate are trained on areas which could help them improve on their performance are lacking. Most managers do not take this system seriously because there are no standard harsh consequences for non-compliance and for those who flawed the system.

The study further reveals that bias and rating errors committed by managers is one of the worst problem faced by employees during their assessment period. Employees are no longer willing and motivated to perform outstandingly knowing that due to bias of their managers and supervisors their score will always be on the same level. It is commonly known that during the performance evaluation process there are many rating errors which are committed by supervisors and managers which mostly some happens unaware while some are intentionally done. The study reveals that in some case managers commit these errors intentionally as a punitive act to those who they do not get along. Because of these continuous challenge in these departments employees have proposed that the current performance management and development system be amended in order to close the current gaps. Najmi,

Rigas & Fan, (2005) "It has become evident in the literature and in business that there is a need to review performance measurement systems in the ever-changing environment of modern markets' (p. 112).

RECOMMENDATIONS

The public service around the world continues to suffer due to poor management of employee's performance as these factors negatively affects the overall performance of organisations. In order to eliminates these current challenges faced by government departments it is strongly recommended that compulsory training for both managers and subordinates on the implementation and management of the system be conducted quarterly (three months). If it is done correctly most of the problems and confusion experienced during the management process of the system would reduce. The use of external change management practitioners to train employees and help to change their negative mind set on the performance management and development system should be considered. Most employees has lost confidence in both their managers and the system itself therefore using external change agent could help restore the trust and confidence of employees on the system and eventually their supervisors and managers. One of the frustrating challenge faced by employee is issues of unresolved performance grievances, thus, strict deadline for resolving performance management and development system grievances irrespective of their nature must be established.

With regard to changing of performance scores by moderating committee without the consent of the employee, a solution to this problem would be that only direct supervisors of the units must present and defend employee's scores to the moderating committee as this can help eliminate changing of scores by the committee because the direct supervisor would be able to defend the employees scores as they work together during the performance contract and therefore the supervisors knows the performance of their subordinates. Departments must ensure that during the budget planning process, personal development plans are budgeted for and the funds must be utilised effectively to ensure that deserving employees are assisted to improve their performance by addressing their performance gaps. Some managers are part of the causes of these challenges in implementing the system, therefore standardised harsh consequences to those who flawed the system must be introduced and enforced. The departments should encourage learning and develop their own internal experts who will manage their system in the near future, while on the other hand benchmarking with organisations which are prevailing in implementing this system both locally (South Africa) and internationally should be considered.

CONCLUSION

The performance management system has been used for centuries to manage employee's performance around the world. Today we still use the performance management system to achieve organisational goal. However refinement has been made to improve the effectiveness of the system and to meet the current needs of the employees and employers. Irrespective of the refinement made to the system the literature and research results continues to reveals that the system still face criticism as it fails to address the needs of the employees. It is evident that the South African national government departments (SANGD) are losing this battle of managing employee's performance by using the current performance management and development system. Commitment and support from management in the managing and implementation of the system is a vital tool to ensure that the objective of the system is achieved. It can be concluded that the current performance management and development system in the South African national government departments need to be amended in order to close the current gaps. Failure to resolve this problem will eventually collapse the standards of services required by the public which will lead to public protest due to poor performance by these departments.

REFERENCES

- Aguinis, H. (2013). 3rd. *Performance management*. Pearson Education: United State of America. pp. 87-100
- Armstrong, M. (1998). 1st Ed. *A practical guide for line managers*. Kogan page limited: London. pp. 141
- Armstrong, M. (2006). 10th Ed. A Handbook of Human Resource Management Practice: Kogan Page Publishers: London. pp 143
- Banfield, P. & Kay, R. (2012). 2nd Ed, *Introduction to Human Resource Management*: Oxford University press: New York. pp. 300
- Beardwell, J. & Claydon, T. (2010). 6th ed. *Human Resource Management: A contemporary approach*: Pearson education limited: Britain. Pp. 481
- Brynard, P. A. & Hanekom, S. X. 2006. *Introduction to research in management-related fields*, 2nd ed. Pretoria: Van Schaik Publishers. pp. 36
- Carol A. A, Muir, S. Hoque, Z. (2014) *Sustainability Accounting, Management and Policy* Journal Vol. 5 No. 1, Emerald Group publishing Limited 2040-8021 DOI 10.1108/SAMPJ-04-2012-0018 pp. 46-67
- Christensen, R. (2006). *Roadmap to strategic HR: Turning a great idea into a business reality*. Library of congress: USA. New York. pp. 141
- Ivancevich, J. M. (1998), 7th Ed: *Human Resource management*: MacGraw-Hill: United State of America. Pp. 263
- Jackson, S. Schuler S. R. and Werner S. (2009) 10th Ed: *Managing Human Resource international student edition*: Cengage learning: United State of America: pp. 314.
- Kumar, R. (2005) 2nd Ed, *Research Methodology: a step by step for beginners*: Sage Publication ltd. London. pp.125
- Hawke, L. (2012) "Australian public sector performance management: success or stagnation?" International Journal of Productivity and Performance Management, Vol. 61 Issue: 3, pp.310-328,
- Klout, L. and Martin, J. (2000) Management Accounting Research: Strategic performance management: A balanced approach to performance management issues in local government, pp. 234
- Mouton, J. & Marais, H.C. (1996). *Basic concepts in the methodology of the social sciences*. Human Science Research Council, Pretoria. , pp.32
- Najmi, M., Rigas, J. & Fan, I. (2005:112). "*A framework to review performance measurement systems*", *Business Process Management Journal*, Vol. 11 Iss 2 pp. 109 – 122.
- Public service Commission, 2014. *Report on the roundtable discussion on the improper management of the performance management and development system (PMDS) which leads to grievances in the public service*. Available at: <https://www.psc.gov.za/documents/reports/2015/PMDSRoundtableReport3feb15Final.pdf>
- Public Service Coordinating Bargaining Council Resolution no 10 of 1999
- Public Service Coordinating Bargaining Council Resolution No. 9 of 2000
- Rusdi, A., Pilcher, R. , Perrin, B. (2012) "Performance measurement in Indonesia: the case of local government", Pacific Accounting Review, Vol. 24 Issue: 3, pp.262-291,

Senior Management Service Handbook, 2003, as amended

The Public Service Act 103 of 1994

The Public Service Regulation of 2001

White paper on Human Resource Management in the Public service of 1997

AN ASSESSMENT OF SUPPLY CONSTRAINTS WITHIN THE LOW COST HOUSING SECTOR IN TSHWANE, SOUTH AFRICA

Vinessa Naidoo and Mbiere Francois Sakata
Tshwane University of Technology, South Africa

ABSTRACT

Supplying low cost housing in the City of Tshwane, South Africa, is still a major problem despite the scale of delivery since 1994. Private developers face many constraints in creating sustainable development. The City of Tshwane must rethink the strategies in order to reach their vision by 2055, to become “The leading international African capital city of excellence that empowers the community to prosper in a safe and healthy environment” (City of Tshwane, 2012, p. 6). The challenges related to informal settlements and rapid urbanisation cannot be ignored. Acknowledging these challenges will necessitate the adoption of holistic approaches to low cost housing delivery. This might decrease the backlog and reduce the number of unrests in the city by creating a place called home.

Keywords: City of Tshwane, housing delivery, low cost housing, private developers, sustainable development.

INTRODUCTION

Housing is a key component of urban development. In South Africa, housing policy intervention is divided into three income groups; from R0 to R3 500 qualifying for a fully subsidised house, from R3 501 to R15 000 known as the gap market or affordable market and R15 001 and more (Department of Housing, 2000). This study focused on the supply constraints faced by private developers in the gap market. In spite of a variety of housing finance policies that are offered to provide shelters, very little new houses are being built by developers in the gap market. South Africa is facing a massive housing backlog with at least 2,1 million low cost housing units still to be built. This situation has resulted in more people living in shacks in informal settlements. Existing private developers, faced with growing challenges are not reaching the target as far as the supply of adequate low cost housing is concerned.

Since 1994, more than 3 million fully subsidised houses have been delivered to low income households; nonetheless, 17% of households that earn between R3 500 and R15 000 per month are considered to be living in inadequate housing due to high demand by individuals and short supply of low cost housing by developers. The problems that this study seeks to address are the shortage in housing supply for low income households and the constraints faced by private developers in the gap market. The aim of this study is to identify the reasons for the shortage of low cost housing and to assess the constraints faced by private developers through the provision of low cost housing for the past 15 years in the city of Tshwane.

LITERATURE REVIEW

According to UN-Habitat (2008), approximately one fifth (2.28 million households in 2002) of South Africa's households lived in previously designated black townships. Of these, approximately one third owned homes, one third rented formal housing and one third lived in informal housing. This is an 89% increase from 1995 when 1.2 million people lived in these areas. These households comprised 21% of all households in South Africa in 2002 and it reflects a significant migration movement from rural into urban areas, with the first point of entry the local

townships. The General Household Survey of July 2011 revealed that, although the percentage of households living in formal dwellings, whose dwellings were fully owned, only increased marginally, from 53,1% in 2002 to 53,6% in 2011, the percentage of partially owning dwellings declined noticeably (Stats SA, 2012). The percentage of households that maintained what is described as ‘other’ tenure arrangements increased from 7,7 % in 2008 to 15,5 % in 2011. Figure 1 below presents the details regarding the households living in informal dwellings per province. At the time of the survey, 15,3 % of South African households were living in ‘RDP’ or state-subsidised dwellings (Stats SA, 2012, p. 2-3).

Figure 1: Percentage of households living in informal dwellings per province, 2011

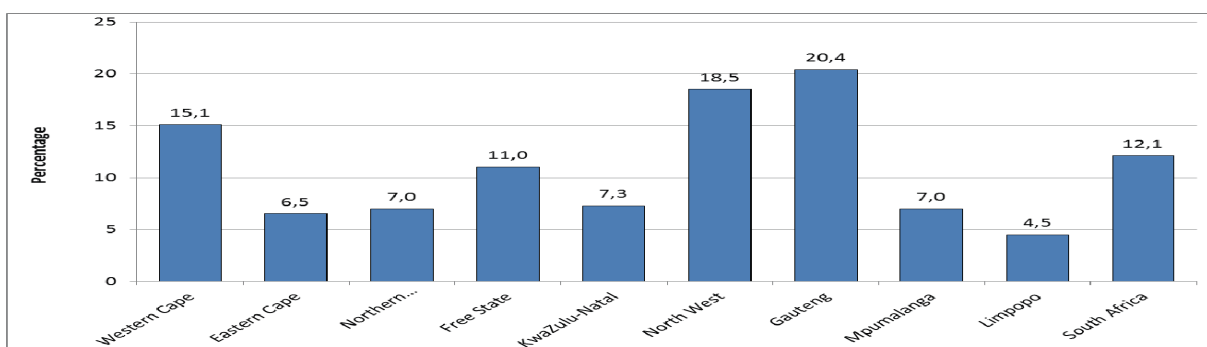

According to Odendaal (2012) regarding the National Development Plan (NDP), South Africa needed to develop adequate, appropriately positioned housing infrastructure, allowing communities access to essential services. For the NDP, currently only 21% of households in South Africa had access to bonds, another 54% qualified for subsidised housing and the remaining 25% did not qualify for a subsidy or a bond, while 15% of individuals in South Africa were unable to independently take care of themselves.

In South Africa, affordable housing or the gap market which is part of the low cost housing, refers to the 25% of households, with an income between R3 500 and R15 000 a month. These households earn too much to qualify for the government’s low-cost full subsidised housing and too little to afford the cheapest standard private sector houses or to qualify for bonds. Houses involved in this sector cost below R350 000 (Odendaal, 2012). Urban low cost housing markets in developing countries are often inefficient and subsidised programmes can add further market distortions. In South Africa, one of the important causes of the inefficiency of the housing market, is the fact that housing policies and construction practices systematically exclude the informal construction sector done by individuals incrementally: the very sector that has been the only source of delivery of affordable housing for the bottom poor. After the transition to democracy in 1994, an ambitious programme of subsidised housing (RDP) was implemented in the country whereby the aim was to construct 1 million low-cost houses over five years. Since then, more than 3.6 million housing units have been built but the housing policies have not created a functional residential market for low income South Africans (Lizarralde and Root, 2008, p. 1). According to Atterhog and Song (2009, p. 266), in order for increased home ownership to be sustainable, it is important to implement a set of measures that not only reduces the barriers to enter home ownership but also helps low-income households to manage the economic risks that home ownership implies.

It is important to note that the private sector, including housing developers, play a direct role on the provision of housing stock, while private financial institutions through the provision of finance mechanisms assist households to either purchase already built houses or construct their own housing. The public sector, on the other hand through different housing subsidies plays a key role in the funding and delivery of housing, while through policies and legislation promotes environment for housing provision and provides regulations (FFC, 2012, p. 22). Khaki (2009, p. iv), suggests that in South Africa, the involvement of the private sector in the delivery of sustainable integrated affordable housing is crucial as this enormous challenges cannot be overcome by the government alone. These challenges to which both the public and private sectors are exposed, relate to availability of land, affordability, subsidy constraints, access to funding and the limitations of development planning.

Despite the increasing expectation that the private sector should play a very important role in financing the down market, the formal financial sector is reluctant to serve the low income sector (UN-Habitat, 2008, p.1). According to Zhang (2008, p. 2), new mortgage providers have emerged but only middle and upper income households have access to such finance, while the poor are generally excluded. According to UN-Habitat (2008, p. 37), the four major banks in South Africa (Absa, Standard Bank, Nedbank and First National Bank) have in general over-lent to the low- and moderate-income market. The loans in default (33 300 in 2008) are constantly mentioned publicly to justify the banking industries' limited exposure to a market that is both politically and economically unstable and considered high risk. Contrary to that and according to Pound (2011, p. 13), in the USA, community based organization seem to do a good job in delivering mortgages to low-income communities; underwriting processes are often more flexible and personal than mainstream lenders and almost always involve counselling and education.

Poor urban housing conditions is a global problem, with the worst conditions in developing countries. According to Zhang (2008, p.1), approximately 1 billion people or one third of the world's total urban population, live in life and health threatening homes. A key challenge in developing housing finance opportunities in Africa is affordability (both in terms of how much people earn and the manner in which they earn it). Innovative initiatives seeking to address this challenge are now clearly operating and realising successes in a number of African countries such as Rwanda, Tanzania and Ghana.

According to Giddings (2007, p. 11), private sector developers, as well as government officials and knowledgeable experts cite the unavailability of reasonably priced and well-located serviced land as the major constraint to the rapid expansion of housing for low and moderate income families. Private developers are forced to look at subserviced land on the outskirts of most urban areas for housing sites, for reasons such as large holdings of land by government, control of large tracts by special private interests (e.g. traditional chiefs and private families in Ghana), poor environmental conditions and a lack of essential infrastructure. It is a common belief that poor countries lack the resources to provide finance for low income housing. However, research shows that poor countries do have capital and the poor save a portion of their earnings. In Egypt, the wealth accumulated by the poor is 55 times more than the foreign direct investment (FDI). In Haiti, the total assets of the poor are more than 150 times greater than all the FDI received since independence in 1804. However, to use the phrase coined by De Soto, these assets are "dead capital" which cannot be transferred in the market. Many poor people live in houses that do not carry any legal titles. Hence, most poor people live in substandard housing and slums which have little exchange value on the market (Zhang, 2008, p. 3).

The international human right policy instruments state clearly that government have the obligations, including legal duties in terms of the various international human right policy instruments, such as covenants, conventions and declarations to enable people to access shelter and to improve their living conditions (Tonkin , 2008: 32). Hoek-Smit and Diamond (2003, p. 5) make the point that in lower income countries like Brazil, Mexico and Indonesia, the majority of newly formed households are not able to afford the lowest priced house in the formal sector housing market. Originally the Mexican housing finance system was completely dependent on government funding. In fact, interest rates on loans especially to first-time low income households are still highly subsidized. For want of private sector participation and risk-sharing, housing finance has been dominated by government sponsored intermediaries. Nowadays, the housing finance system is fully supported by private sector funding, risk-sharing, originating, servicing and mortgage insurance. Housing policies are targeted more specifically at certain groups such as single parents or ageing people (Burgoyne, 2008, p. 10).

Le Roux (2011, p. 40), investigating the ways in which Brazil, Argentina and Peru addressed their housing challenges, proved that certain factors are necessary for housing provision programmes to be successful, namely effective government, social capacity and public-private partnerships. Le Roux (2011, p. 29) also noted that the housing challenge is quite different from what South Africa experiences. For many Western housing systems, at the beginning of the twenty-first century, the housing question appears to have been answered. Sweden, for instance, has achieved an enviable standard of living under a mixed system of high-tech capitalism and extensive welfare benefits.

According to Zhang (2008, p. 5), research shows that most low income households aspire to own houses but housing is the most expensive asset for most. The substantial investment required to buy a finished unit is often way beyond the means of low income households. In developing countries, the vast majority of low income households have built their houses incrementally over long periods of time. The incremental process of construction reflects their limited financial resources. It also creates emotional ties between families and their houses; as a result, poor families may be more reluctant to use their houses as mortgages for loans.

The credit culture has a major impact on the financial sector. A poor credit culture results in significant increases in banking risks. For example in the year 2000, one Tanzanian State owned bank had a 44% bad loan rate (Zhang, 2008, p. 6). Another issue associated with poor credit culture is lack of credit information systems. In many developing countries credit information systems are lacking or still in an infancy stage. The high default rate and non-sustainability of many microfinance institutions, which specialize in lending to the poor, point to the problems caused by the absence of credit information systems (Zhang, 2008, p. 6). One of the reasons for maintaining such high spreads was to compensate for low utilization costs. This practice brings additional challenges to individuals for the vast majority of individuals and next to impossible for those with a low income (Zhang, 2008, p. 8). To banks, the risk of credit default is higher with the poor as their circumstances are more likely to change over time than for any other segment of the population. The amounts they borrow tend to be relatively small, maturities are short and transaction costs are higher. Therefore, the formal banking sector is reluctant to enter this market. Many lenders in this market manage customer repayments, rather than relying on customers to pay on time. Agents collect repayment from customers contribute further to high lending costs (Zhang, 2008, p. 8).

RESEARCH METHODOLOGY

An empirical field-based research method using self-administered survey questionnaires, was used to gather primary data. The target group was key developers working in the low cost housing sector in the city of Tshwane and registered with The National Home Builder Registration Council (NHBRC). Secondary data was extracted from data available at the National Department of Human Settlements, City of Tshwane Municipality, NGO's, Deeds office and the growing research literature available in South Africa. Data were analysed quantitatively by means of descriptive statistics. Stata package using correlational statistics, inferential statistics and analysis of variance was used to investigate the relationship between different reasons for the poor delivery of low cost housing by private developers in the city of Tshwane.

RESEARCH FINDINGS AND INTERPRETATION OF RESULTS

A sample of 150 private developers was chosen to participate in the survey. Of the 150 distributed questionnaires, 84 came back, correctly completed. This represents a response rate of 56 %. The respondents were asked to indicate their gender, the number of years spent in the construction sector in general, their designation and to confirm whether the respondent is registered or not with NHBRC as it is requested that all new houses be inspected during the building process to ensure that developers comply with the relevant Act.

Inferential Statistics

The Pearson Chi-square test of association, using Stata V12 statistical software, was performed to determine whether or not there is a relationship between the number of years of work in the Gap market, number of projects completed in the Gap market and number of houses completed in the Gap houses in the city of Tshwane Municipality since 1994 to 2013. It should be noted that none of the p-values was more than 0.05. This indicates no correlation between the variables concerned in the number of years of work in the Gap market, against the constraints faced by developers in delivering gap houses in the city of Tshwane Municipality since 1994.

In the cross tabulation for the variable, number of projects completed in the Gap market in the City of Tshwane Municipality since 1994 and the constraints faced by developers in delivering these projects, only one

correlation was found. The p-value for the variable “Inappropriate municipal standards” is 0.047. This indicates that this variable is not independent of the constraints faced by developers in the Gap market; therefore there is an association with the constraint. The implication is that inappropriate and new standards contribute to increased unit cost of housing delivery by a developer over time. For example, an increase in a minimum size of a housing unit as a norm affects the unit cost and number of units to be delivered.

Table 1 below presents the p-values with a correlation between the variable concerned in the number of houses completed in the Gap market in the city of Tshwane Municipality since 1994 and the constraints faced by private developers in delivering the houses. The variables “Buyers are not willing to consider alternative building materials”, “Municipalities are not willing to consider alternative building materials” and “Very slow municipal processes before final approval for construction to commence” have p-values less than 0.05, which is 0.006, 0.023 and 0.018 respectively. This indicates that these variables are not independent of the constraints faced by developers in the Gap market; therefore there is an association with the constraints. The implication for the variable that buyers are not willing to consider alternative building materials, is that the government cannot consider the use of alternative and innovative building materials to address the backlog. The implication for the variable that the local government is unable, and in some cases unwilling, to make the necessary decisions to implement new practices, is that communities often do not have access to relevant information and hence are unable or unwilling to pay for such services. The implication for the variable relating to the existence of several building codes, parallel processes from different departments, approval delays and long process for a township establishment results in low-density zoning laws that stretches time for construction commencement and increases financial costs incurred by the developer.

Table 1: P-values for the number of houses completed in the Gap market houses against the constraints

Id	Constraints	P-values
15	Buyers are not willing to consider alternative building materials	0.006
17	Municipalities are not willing to consider alternative building materials	0.023
19	Very slow municipal processes before final approval	0.018

Reliability Analysis

Cronbach’s alpha, with a cut-off point of 0.70, was used to test for internal consistency. Where Cronbach’s alpha was less than 0.70, factor analysis was performed for the purposes of data reduction. The individual alpha tells how the overall alpha would improve if that item was to be removed from the questionnaire. Table 2 below indicates the variables with alpha equal to or higher than 0.70. This means that these items reliably tested the intended latent constructs. For those constraints with alpha less than 0.70, can be ignored, as these items proved to be unreliable.

Table 2: Calculation of Cronbach’s alpha for the challenges

Id	Challenges	Obs.	Sign	Alpha
7	Rising cost of construction materials	76	+	0.7453
8	Rising labour costs	76	+	0.7382
9	Rising cost of professional fees	76	+	0.8216
10	Inappropriate municipal standards	76	+	0.7047
11	Cost of capital financing when borrowing money	76	+	0.7788
13	Lack of adequate skills base at councils	76	+	0.7093
17	Municipalities are not willing to consider alternative building materials	76	+	0.708
18	The affordable housing threshold of R300k	76	+	0.7701
19	Very slow municipal processes before final approval	76	+	0.8236
20	Long lead times to get final approval	76	+	0.7912
21	Growing population that is becoming more and more urban	76	+	0.7928
22	Fragmented housing policy and administrative systems	76	+	0.7543

CONCLUSIONS AND RECOMMENDATIONS

This paper makes a contribution to the knowledge of housing supply and the role of private developers in housing delivery. The City of Tshwane needs to rethink the strategies in order to reach their vision by 2055 with regards to low cost housing. On the other hand, the challenges related to informal settlements and rapid unmanaged urbanisation cannot be ignored.

In this paper, the majority of the respondents across all designation, scored high on the constraints identified in delivering affordable housing in the City of Tshwane since 1994. The Chi-square test of association performed during the study, revealed that there is an association between the number of projects completed in the Gap market with the constraint “Inappropriate municipal standards”. To resolve this issue, Government must set clear housing standards, so that developers from the start of every housing project, developed a proper project management plan with appropriate costs to define their interest in taking such a project or not.

Further Chi-square test of association was also performed during the study to analyse the relationship between the numbers of houses completed in the Gap market housing in the City of Tshwane by these respondents and the constraints identified. The paper revealed the following new results:

The p-value for the variables, “Buyers are not willing to consider alternative building materials”, “Municipalities are not willing to consider alternative building materials” and “Very slow municipal processes before final approval for construction to commence” are all less than 0.05. This indicates that these variables are not independent of the constraints faced by developers in the Gap market. To resolve this constraint the Government need to consider the use of alternative and innovative building materials to address the backlog. The problem associated with using such building techniques or materials relates to the lack of knowledge by new home owners in addition to governments limited procedures to educate individuals about alternative building structures. The implication for constraint 17 (see Table 1) is that as Local government is unable, and in some cases unwilling, to make the necessary decisions to implement new practices, communities often do not have access to relevant information and hence are unable or unwilling to pay for such services. These two constraints and opportunities if solve properly make up a framework for thinking about positive and innovative housing solutions that offer a step forward in terms of organisational development, human resource management, resource use, economic cost, environmental sustainability, socio-economic responsibility as well as liveability as it is the case in some developed countries.

The implication for constraint 19 (see Table 1) is that the existence of several building codes, parallel processes from different departments, approval delays and long process for a township establishment, low-density zoning laws in the city of Tshwane, stretches time for construction commencement and increases financial costs incurred by the developer compares to other countries where these processes are clear. To increase delivery, there must be closer alignment between provincial and national departments in driving affordable housing delivery. Although, these are the significant constraints depicted by inferential statistics, the results from descriptive analysis, that score high, cannot be rejected and must be taken into consideration; though that many of these constraints in relation with technical and physical, housing finance constraints and policy and institutional constraints are equally important.

In contrast with existing literature on the already stated combined constraints associated with land, affordability and financing; this study is an indication that the City of Tshwane and all stakeholders, should come up with measures such as consumer education programmes and communication strategy towards beneficiary, to address the challenges to accept new building material and put in place efficient structure at all three spheres level of government that deal with standards and administration of the process. This study represents a number of opportunities for future research in the supply side of affordable housing market in developing countries such as management of alternative building technology in the low cost housing sector. The findings of the study could be added to the existing number of literature available. The City of Tshwane could use this study for implementation of a reliable low cost housing strategy that will bring back developers in this market and increase the supply to meet the demand. This study will help to open ways for further engagements between the city of Tshwane and private developers.

That said, if care to resolve the constraints identified are not taken seriously; the number of people living in slums will only increase, putting pressure on the government. This will have a major impact on the economy and spatial development of the city. Notwithstanding the challenges identified, the city of Tshwane has the foundation to create better human settlements for the low income earners that support the economic development and serve a broader range of the population as well as offering learning opportunities to the international community.

REFERENCES

- Atterhog, M. & Song, H.S. (2009). A survey of policies that may increase access to home ownership for low-income. *Housing, Theory and Society*, 26(4), 248–270.
- Burgoyne, M. (2008). *Factors affecting housing delivery in South Africa: A case study of the Fisantekraal housing development project, Western Cape*. Master's thesis. University of Stellenbosch.
- City of Tshwane. (2012). Tshwane vision 2055. Remarking South Africa's Capital City. Retrieved October 14, 2013, from <http://www.tshwane.gov.za/Documents/pdf>
- Department of housing. (2000). National Housing Code. Pretoria
- Financial & Fiscal Commission of South Africa. (2012). *Housing finance options analysis: For an equitable sharing of national revenue*. Retrieved February 20, 2013, from: <http://www.ffc.co.za>
- Giddings, S.W. (2007). *Housing challenges and opportunities in Sub-Saharan Africa. International housing coalition*. Retrieved July 04, 2013, from: <http://www.intlhc.org>
- Hoek-Smit, M.C. & Diamond, D.B. (2003). *The design and implementation of subsidies for housing finance*. Prepared for the World Bank seminar on housing finance. March 10 -13, 2003. Retrieved May 20, 2017, from: <http://www.housingfinanceforthepoor.com>
- Khaki, I. (2009). Housing in South Africa: The challenge to provide sustainable, integrated, affordable housing. MBA thesis. University of Stellenbosch.
- Le Roux, F.E. (2011). *The provision of low cost housing in South Africa: A wicked problem with a systems theory solution*. Master's of Philosophy dissertation. University of Stellenbosch.
- Lizarralde, G & Root, D. (2008). The informal construction sector and the inefficiency of low cost housing markets. *Construction Management and Economics* (26), 103–113.
- Odendaal, N. (2012). *Adequate, appropriately positioned housing key to SA development*. Retrieved July 26, 2013, from: <http://www.engineeringnews.co.za/article/adequate-and-appropriately-positioned-housing-key-to-sa-development>.
- Pound, A. (2011). *Challenges and changes in community-based lending for homeownership*. Joint Center for Housing Studies of Harvard University. Retrieved February 25, 2013, from: <http://www.Jchs.harvard.edu/research>
- Statistics South Africa. (2012). *General household survey 2011*. Statistical release P0318. Retrieved February 27, 2013, from <http://www.statssa.gov.za/publications/P0318/P0318April2012.pdf>
- Tonkin, A. (2008). *Sustainable medium-density housing*. A resource book. Development Action Group. Cape Town.
- UN-Habitat. (2008). *Housing finance system in South Africa. The human settlements finance systems series*. Retrieved February 23, 2013, from: <http://www.unhabitat.org>
- Zhang, X.Q. (2008). *Housing for all: The challenges of affordability, accessibility and sustainability. The experiences and instruments from the developing and developed worlds. A Synthesis Report*. Kenya.

IMPACT OF WASTE MANAGEMENT TECHNIQUES OF INDUSTRIAL PARKS IN SOUTH AFRICA

Takalani Nemarumane and Charles Mbohwa
University of Johannesburg, South Africa

ABSTRACT

The rapid human population increase and expansion of resource-consumption, combined with industrialization, urbanization, mobilization, agricultural intensification and resource intensive life styles are contributing to worldwide environmental, social and economic crisis. The methods used to collect the data were questionnaires and interviews, these were analysed using the Statistical package for Social Science. South Africa produces millions tons of waste per year. This is mostly industrial waste from the processing of natural resources into industrial products, and the rest is municipal waste. A huge percentage of this waste is either incinerated or dumped in landfills. Municipalities and industry are thus in a difficult position, challenging them to find waste management practices alternative to incineration. Waste reduction and minimization efforts need to be increased and the problem clearly calls for going a step further by initiating an industrial ecology approach

Keywords: Industrial Waste, Waste Management, Ecology, Resource Sustainability, Recycling.

INTRODUCTION

South Africa produces millions tons of waste per year. This is mostly industrial waste from the processing of natural resources into industrial products, and the rest is municipal waste. A huge percentage of this waste is either incinerated or dumped in landfills. Municipalities and industries are thus in a difficult position, challenging them to find waste management practices alternative to incineration. Waste reduction and minimization efforts need to be increased and further initiatives taken towards industrial ecology.

South Africa generated approximately 108 million tons of waste in 2011, of which 97 million was disposed of at landfill. In the order of 59 million tons is general waste and 49 million tons is unclassified and hazardous waste. In the order of 10% of all waste generated in South Africa was recycled in 2011 (CSIR and COWI, 2012). This is mostly industrial waste from the processing of natural resources into industrial products, and the rest is municipal waste. A huge percentage of this waste is either incinerated or dumped in landfills.

LITERATURE REVIEW

Industrial parks are a cardinal unit of economic development; industrial parks have been playing an important role in the national development strategies of many countries and have been irreplaceable where economic development is concerned (Geng and Hengxin, 2009). There are many different terms for industrial parks, which vary depending on the scope and type of operations, hence many industrial types exist, this research will also help open up an opportunity to establish the most sustainable or eco-efficient industrial park in relation to these industries (Geng and Hengxin, 2009).

EIP considers the coordination of economic development and environmental protection, and defined as “a community of manufacturing and service businesses located together on a common property.” Member businesses seek enhanced environmental, economic, and social performance through collaboration in managing environmental and resource issues. By working together, the community of businesses seeks a collective benefit that is greater than

the sum of individual benefits each company would realize by only optimizing its individual performance (Lowe, 2001).

Although the construction of EIPs or low carbon industrial parks is quite popular, the sustainability assessment of industrial parks is a topic that has not been well documented. In literature most sustainability studies on industrial parks fail to link the infrastructure developments to the energy system thus focusing more on limited aspects such as direct energy consumption, environmental impacts, economic or social performance, or inner metabolism (Lowe, 2001).

EIP and low carbon industrial park may offer multifaceted benefits to the users; it naturally follows that any sustainability assessment of the industrial park ought to adopt a multi criteria methodology. Hence, sustainability assessment of industrial parks should be illustrated considering the dimensions of environmental, economic, resource sustainability.

One eco-industrial park that's widely seen to be doing that is in Kalundborg, near Copenhagen. Set up in 1961, it's grown over the decades to include some 30 companies and is considered one of the world's most cutting-edge eco-industrial projects (Deutsche Welle 2015).

Countries currently applying Eco-Industrial Park Technology to reduce waste generated

The Kalundborg Eco-Industrial Park, near Copenhagen was set up in 1961, it has grown over the decades to include approximately 30 companies and is considered one of the world's most cutting-edge eco-industrial projects (Deutsche Welle , 2015).



Figure 1: Kalundborg EIP in India (Deutsche Welle, 2015)

The Kalundborg eco-industrial site is considered to be one of the most progressive in the world. The waste from one company provides a resource for the other. For instance, steam from a power plant is captured and used by a pharmaceutical company. Excess heat is used to heat local homes. Another by-product from the power plant, gypsum, is used by a plasterboard manufacturer. A by-product of the pharmaceutical company, yeast cream, is used to feed pigs at a local farm (Deutsche, 2015). “The companies get all the material they need, the materials get recycled and the production process is thus much cleaner,” Berndt Jespersen, technical advisor at the Kalundborg project said (Deutsche, 2015). “So, we're basically taking resources from the earth and returning them to the earth (Deutsche, 2015).” This technology reduces waste to while also minimising raw materials needed.

METHODOLOGY

Both primary and tertiary data was used to analyse the study, the primary collected in a form of Survey questionnaires, observations and Interview. The questionnaire used was generated by the researchers. The main tool used was questionnaire as it was given to all the industries that accepted the survey question, only few selected companies were interviewed and done the thorough observations. The questionnaires were also sent to more than 4000 companies on email from the database received from CSIR and only few companies responded. Most of them never comment anything and a few denied openly. The secondary data was mainly on literature, previous reports and database.

The study was conducted using both the qualitative and quantitative research. The overall number of the industries that were given survey questionnaires is 200 and 14 responded and most on them are on the waiting list. Researchers are still flying out more questionnaires to other companies within the park hoping to get more responses. The survey questionnaire were analysed using the excel spreadsheet, the observations and interviews are used mostly on the recommendations.

RESULTS

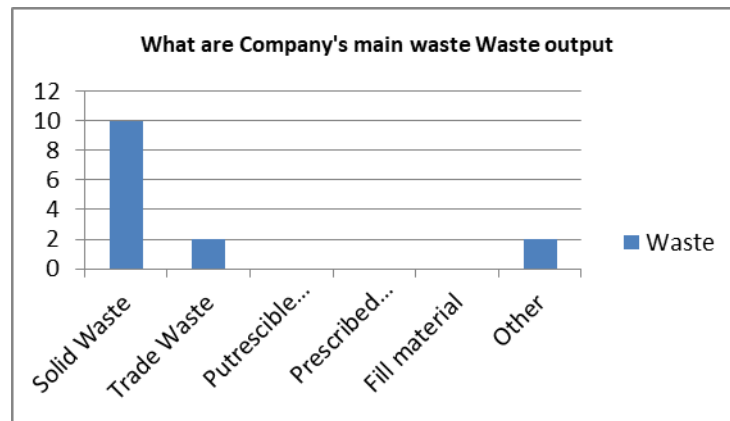

Figure 2: Companies most output

The most experienced waste in South African Industrial parks the solid waste followed by the trade waste and other wastes as shown by figure 2. It was found that most Industrial parks that participated in the study do not educate their workers on the different types of waste, or on how they can be handled. Most of the waste generated is disposed in one bin and is all mostly considered as solid waste. The other main problem was that companies do not to know where to take their waste and how it could be useful to other industries as well as their own industries.

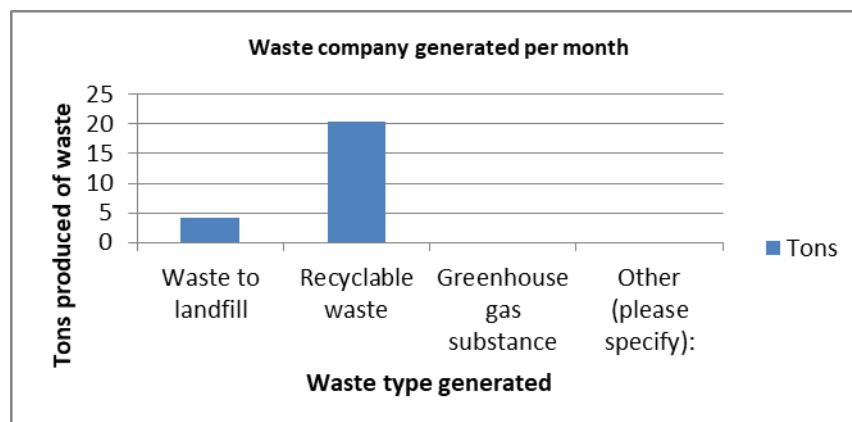

Figure 3: Waste generated per month

The Industries normally generate waste to landfill and recyclable waste and none related to air pollution and other waste in relation to monthly generated waste as depicted in Figure 3. This is because the landfill and recyclable waste can be easily identified. The Industrial Parks do have the skills to recycle the waste that is generated, however they are aware that some of the waste can be recycled as depicted in figure 3.

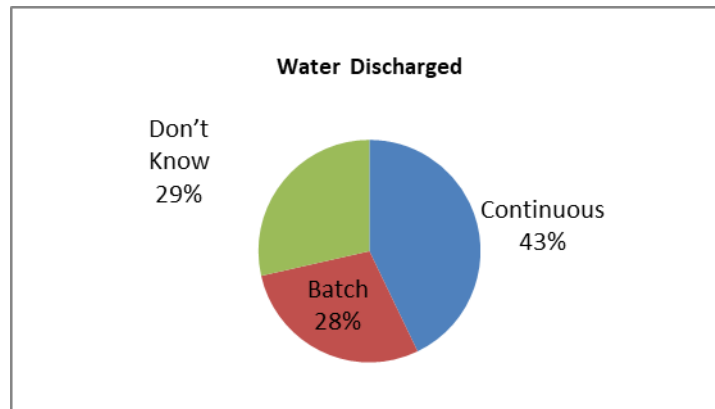

Figure 4: Discharge of water

Industries stated that they are using various techniques to discharge waster. 43% of the industrial parks are using continuous method to discharge water while 28% use the batch method, as indicated in figure 4. It was further found that 29% of these industrial parks do not know the method that they use to discharge water, as many had not gained knowledge in this area.

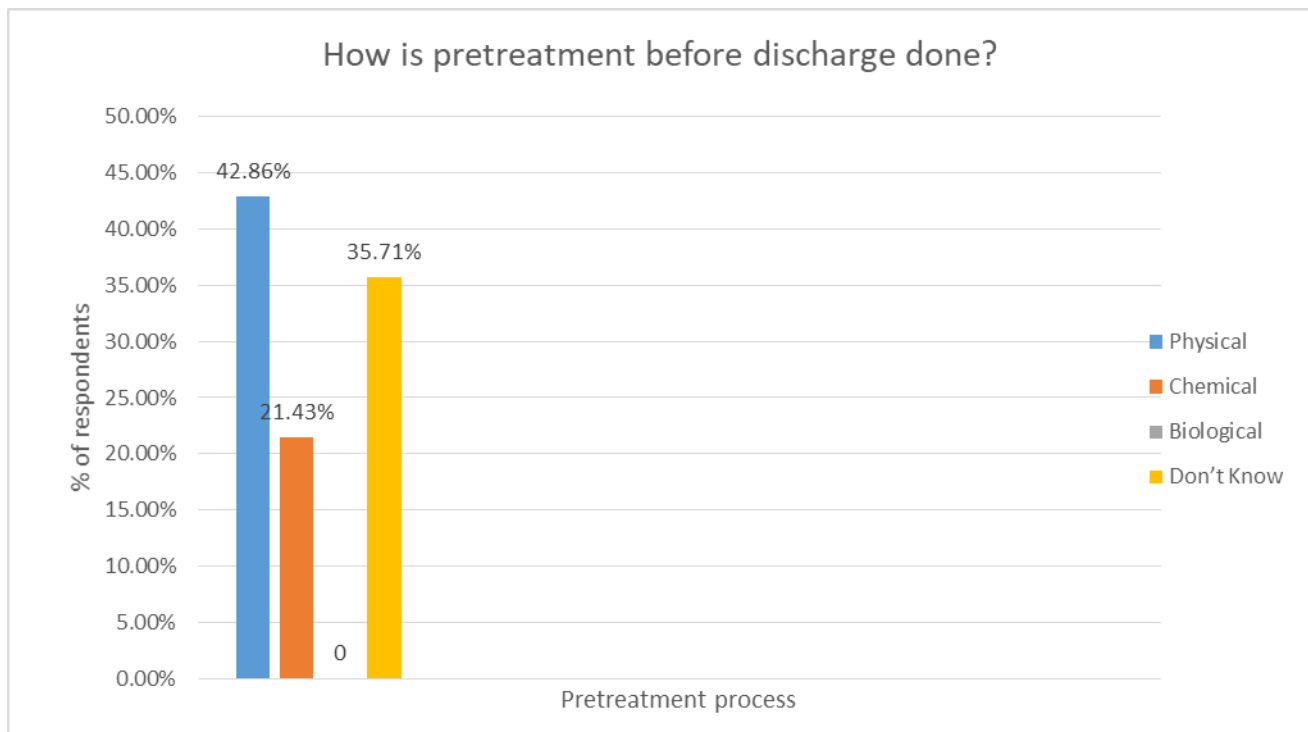

Figure 5: Pretreatment processes used before discharge

It was found that 21.05% of the industrial parks that conduct pretreatment before waste water and effluents discharge use the physical processes such as Screening, Floation and Skimming. As indicated in figure 5, 73%.

68% are unaware of the pretreatment process used, while 15.79% use the chemical process known as neutralization. It was further found that none of the industrial parks use any of the biological process, including Trickling, Filtration, Anaerobic Digestion or septic tanks.

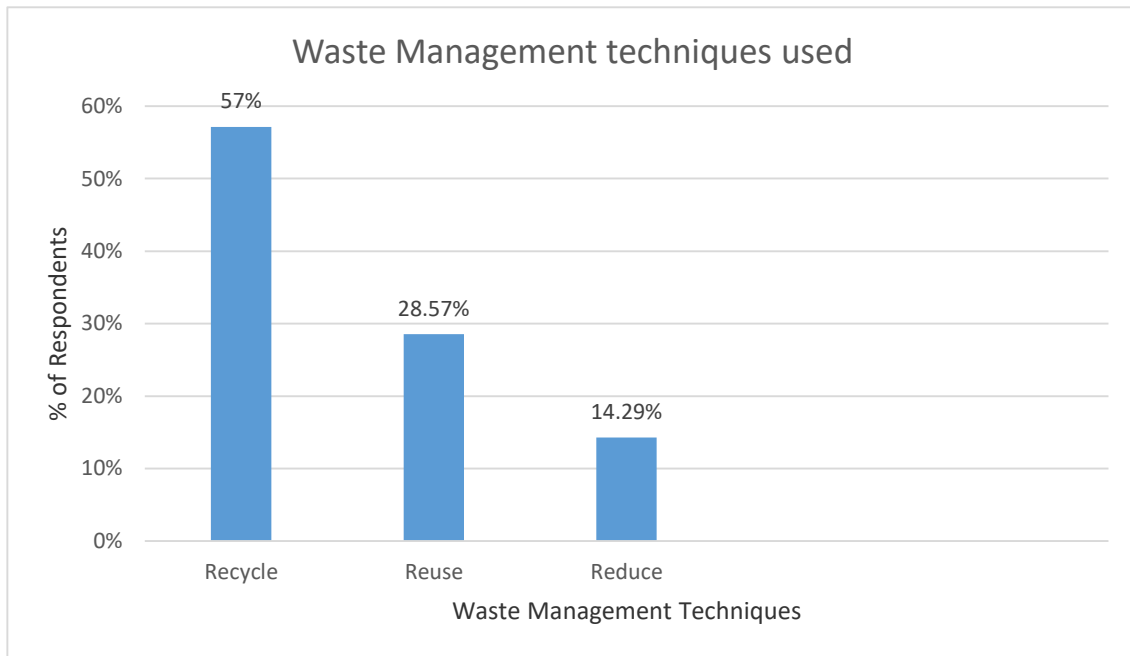

Figure 6: Waste Management techniques currently used.

Industrial parks are aware of the various techniques that can be used to manage waste. 57% of the industrial parks suggested that recycling the waste produced would be a viable strategy, it was however identified that the industrial parks are not knowledgeable on the process of recycling, whereas 28.57% suggested reusing and 14.29% suggested reducing the waste produced, this is indicated in figure 6. None of the industrial parks suggested burning or burying of the waste produced.

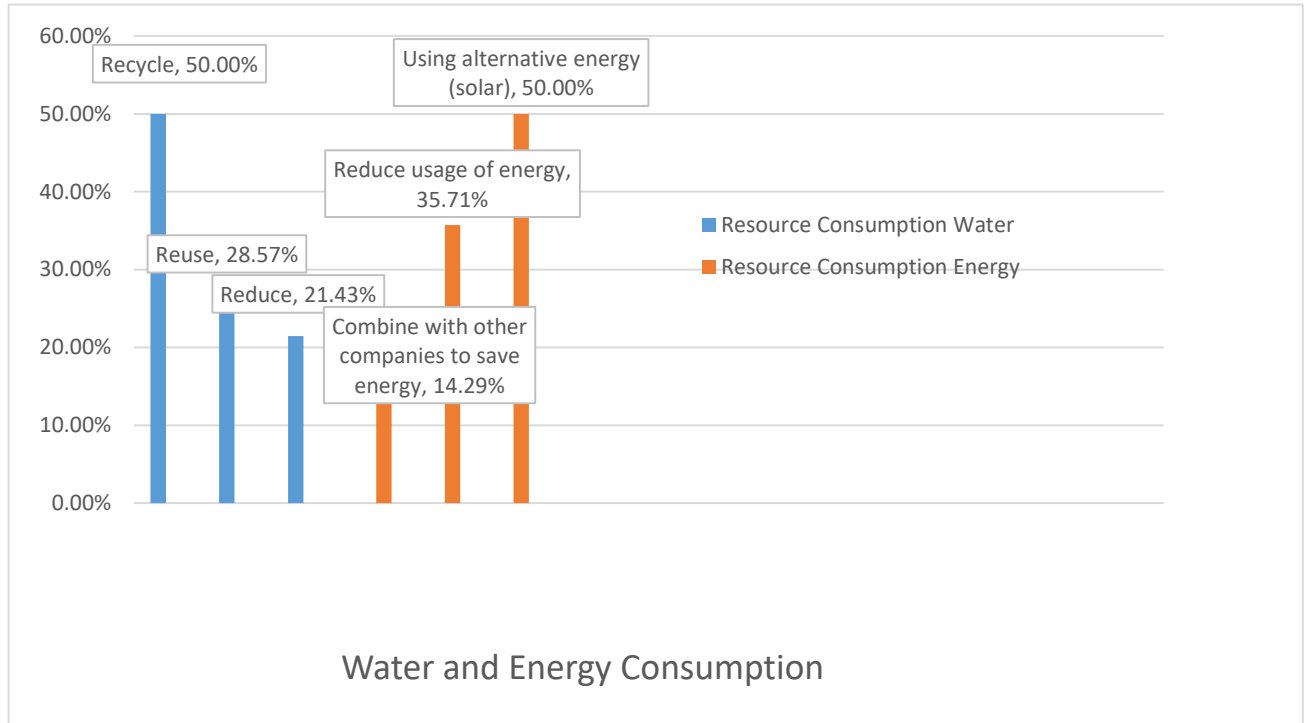

Figure 7: Energy and Water consumption in Industrial Parks

The industrial parks were specifically analysed in the consumption of water and energy, and further on the measures that could employ to reduce these resources. It was found that in terms of water consumption, 50% recommended recycling of water as an alternative, while 28.57% recommended the reusing of water and 21.43% stated reduce water consumption as an appropriate alternative. With regard to energy consumption, 14.29% of industrial parks stated that combining energy usage with other businesses would be the best means of saving energy. 35.71% recommended reducing energy usage and 50% stated that an alternative energy source such as solar would enable the saving of energy in industrial park businesses. This is illustrated in figure 7.

RECOMMENDATIONS

Five mechanisms have been proposed by the researchers to promote industrial symbiosis:

- Working through public-private partnerships, for example, between local authorities who operate treatment facilities and landfill sites, industries that discharge problem waste to these facilities and sites, waste companies that specialize in waste re-use and recycling, and national government that is responsible for legislative guidelines;
- Using the South African National Cleaner Production Centre (NCPC) to develop and assist with the implementation of appropriate technologies and procedures for industrial symbiosis;
- Use of trading platforms to link waste generators and waste re-users and recyclers;
- Introducing funding mechanisms, particularly to enhance and support the exchange of low value commodities; and
- Linking waste minimization clubs, waste exchanges and future industrial ecological parks and zones

Waste Management

Development of waste management software for industrial parks

Industrial material flow management is able to contribute substantially to an increase in resource efficiency by systematically promoting the recycling and reuse of materials and components. The IUWA Waste Manager software is aimed at meeting both the individual company's internal needs regarding waste related information and analysis as well as the requirements for inter-company exchange and coordination. The software is composed of a set of connected tables consisting of basic data entries, and would assist industrial parks in terms of identifying and managing information on substances, waste and places involved in the disposal process as well as accounting data (Krause W, Guo B and Assmann O, 2012).

Waste material recovery facility

The installation of a waste material recovery facility will enable the industrial parks to convert waste into energy. Converting waste into energy is a powerful solution to the issue of climate change, because it substitutes fossil fuel and restrains methane emissions. The Korean government has adopted the Measures concerning Waste Resource and Biomass Energy and its implementation strategy, and has actively facilitated waste-to-energy initiatives, such as the production and development of refuse-derived fuel (RDF) generated from inflammable waste and biogas from organic waste. This is illustrated in figure 8.

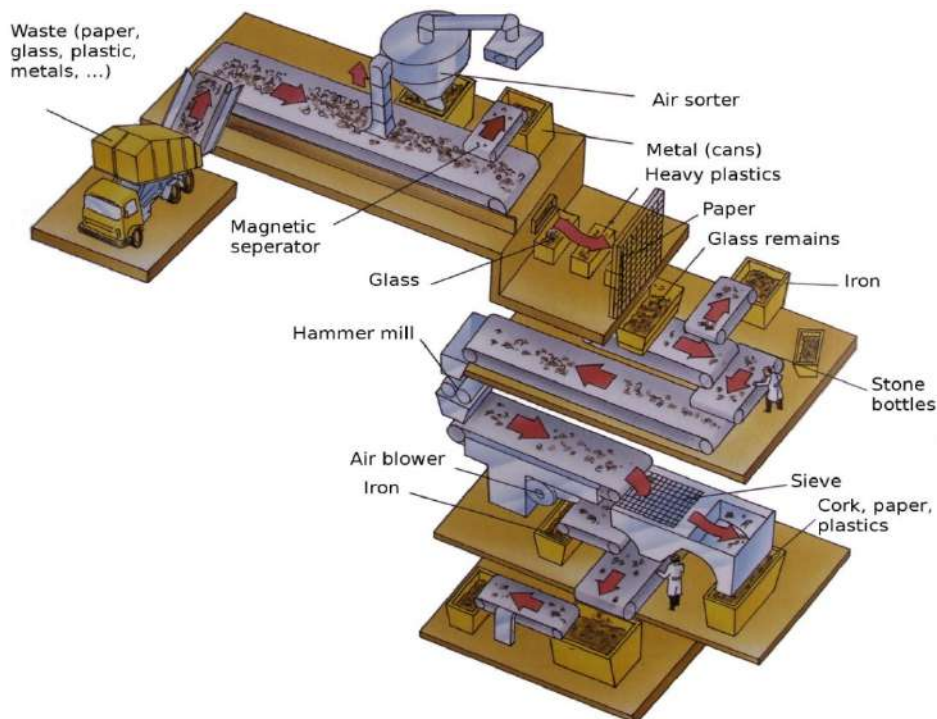

Figure 8: Waste material recovery facility

To maximize the waste-to-energy effect in the future, the plan to expand and centralize waste-to-energy facilities and to create an environmental energy park would have to be initiated. An experimental complex with natural power and a bio-energy town equipped with RDF generator and boiler, a biogas converter for hazardous sewage, an energy converter for sewage sludge, and a landfill gas processing facility should be constructed in the industrial park. It is expected that 43% of waste can be converted to energy using this technology. Furthermore, there is a need for improving policies and reforms laws intended to promote waste-to-energy activities, such as the enforcement regulation of the Wastes Control Act.

Creation of waste sinks

Since the beginning of the industrial revolution, the practice of dispersing waste and emissions into the environment untreated or partially treated has allowed firms to externalise many costs and to lower the price of goods and services to consumers. This is no longer sustainable. Waste must no longer be seen as something that is harmful, but as a potential resource for use by current and future generations. The concentration of waste, except for landfill and incineration sites, has been severely restricted by planning on health and safety grounds. However, just as most industries gain advantage from the location externalities, there are opportunities to be gained from waste agglomeration. The creation of waste sinks or concentrations in industrial parks creates economies of scale, continuity of supply and critical flow mass of waste materials or energy. Waste reprocessing and energy recovery industries can be stimulated to develop. The industries convert waste/energy into materials and services that are sold to manufacturers and processors in the same locality or elsewhere.

Industrial Ecology Integrated and Long-Term approach

Ecology is defined as the scientific study of the interactions that determine the distribution and abundance of organisms. A multi-disciplinary and integrated approach to the planning and management of manufacturing areas is required to foster industrial ecology. It must be strategic and long term. Industrial ecology developments take many years to nurture, but the key elements of infrastructure must be laid down early in the strategic planning process to encourage the incubation of new firms. The inherent risk must be accepted by either the private sector, the public sector or some combination of both of them (University of Tampere , 2006).

CONCLUSION

Industrial Symbiosis is one of the main characteristics of an Industrial Park. There are a number of ways that this symbiosis can be achieved. 35% of surveyed companies are able to sell their by-products to other companies for re-use. This shows a lot of potential in this avenue of symbiosis. As more knowledge is made available to the companies the response will improve. Collaboration with other companies for energy efficiency is a huge challenge. 35% of the companies have not explored it. There is need to access why this is the case and come up with ways of encouraging these companies to try this out. Reducing the amount of and recycling water that each company is using is the easiest to do from this survey. About 50% are doing these two. In an ideal Industrial Park companies that are able to change materials with others or exchange waste and by-products should be in one place. The closest the situation can get to this the more efficient the Industrial Parks will be.

REFERENCES

- CSIR and COWI. (2012). *NATIONAL WASTE INFORMATION BASELINE REPORT*. Pretoria, South Africa: Department of Environmental Affairs.
- Deutsche Welle. (2015). *Environment*. Retrieved March 28, 2016, from Eco parks offer firms a low-carbon road to growth: <http://www.dw.de/eco-parks-offer-firms-a-low-carbon-road-to-growth/a-6532982>
- Fang. (2008, August 26). *The Encyclopaedia of the Earth*. Retrieved March 28, 2016, from Eco-industrial parks in China: <http://www.eoearth.org/view/article/151922/>
- Geng Y, Haight M and Zhu Q. (2005). Empirical Analysis of Eco-Industrial Development in China. *Sustainable Development*, 1-13.
- Krause W, Guo B and Assmann O. (2012). *Meeting the Resource Efficiency Challenge in a climate sensitive dryland megacity environment. Urumqi as a model for city central Asia*. Asia: IUWA.
- Lowe. (2001). *Handbook for development of eco-industrial parks indigo development*. USA.
- Research and Innovation. (2012). *A sustainable future for Europe's industrial parks*. Retrieved March 27, 2016, from A sustainable future for Europe's industrial parks: http://ec.europa.eu/research/environment/newsanddoc/article_3892_en.htm
- University of Tampere . (2006). *A background report for the eco-industrial park project at Rantasalmi Laura Saikku Research Institute for Social Sciences*. India: PUBLICATIONS OF REGIONAL COUNCIL OF ETELÄ-SAVO
- UNIDO and UNEP. (2014). *Green Industry Platform*. Retrieved March 28, 2016, from Green Industry Platform: <http://www.greenindustryplatform.org/?p=2315>

BENEFITS OF IMPLEMENTING ECO-INDUSTRIAL PARKS IN SOUTH AFRICA THROUGH SUSTAINABLE DESIGN

Takalani Nemarumane and Charles Mbohwa
University of Johannesburg, South Africa

ABSTRACT

Eco-industrial parks offer firms the opportunity to cooperatively enhance both economic and environmental performance through increased efficiency, waste minimization, innovation and technology development, access to new markets, strategic planning, and attraction of financing and investment. The methodology used was both qualitative and quantitative. Primary data was collected using questionnaires and interviews. Currently in South Africa, environmental protection is ignored at the expense of economic development. Sustainable development and design aims to lower costs and improve the environment simultaneously. Eco-Industrial Parks consider the coordination of economic development and environmental protection, and defined as “a community of manufacturing and service businesses located together on a common property. Member businesses seek enhanced environmental, economic, and social performance through collaboration in managing environmental and resource issues.

Keywords: Eco-industrial parks, Limited resources, Sustainable development, technology development, industrial efficiency.

INTRODUCTION

Eco-industrial parks are emerging as the primary arena for testing and implementing industrial ecology. Similar in some respects to standard industrial parks, eco-industrial parks are designed to allow firms to share infrastructure as a strategy for enhancing production and minimizing costs (Smart Communities Network, 2005). Eco-industrial parks offer firms the opportunity to cooperatively enhance both economic and environmental performance through increased efficiency, waste minimization, innovation and technology development, access to new markets, strategic planning, and attraction of financing and investment (Smart Communities Network, 2005). The Eco-Industrial Park (EIP) concept was first formalized in 1992-93 by Indigo Development, a team of people from Dalhousie University in Nova Scotia, and Cornell University's Work and Environment Initiative (Dartmouth University, 2006).

Companies around the world, especially in booming developing nations, are under pressure to clean up production. Eco-industrial parks offer a way for firms to become greener as well as help boost their bottom line (Deutsche Welle 2015). The German Agency for International Cooperation (GIZ) has initiated an eco-industrial park project in Andhra Pradesh, a state in South Eastern India (Deutsche Welle 2015). A factory in Gujarat, India, emits smoke into the air Smoke-belching factories are a common sight in parts of India (Deutsche Welle , 2015). This can be addressed by an EIP. It aims to upgrade existing industrial parks, which are more than 30 years old and home to hundreds of small and medium sized firms across sectors such as chemicals, food processing and engineering. The retrofit includes adding modern sewage systems, solar lighting, green landscaping and storm water drains (Deutsche Welle 2015).

LITERATURE REVIEW

Eco-industrialism is a voluntary, market-driven approach that uses the discipline of internal and external markets to assure price, performance and quality. Eco-industrialism supports the end results of profit enhancement and frugal use of resources, but it asks us to rethink the relationships, the effect of products on ecosystems and the impact of the processes of production on employees and affected communities. Figure 1 shows how as reducing waste and unnecessaryness in the business can increase profit for the business (Centre of Excellence in Cleaner Production (CECP), 2007).



Figure 1: Reducing waste and increasing economy (Centre of Excellence in Cleaner Production (CECP), 2007)

South Africa’s future should be more focused on industrial symbiosis as China is emphasising on currently. With regard to political support, China’s central government has played a key role in encouraging EID. As the national agency on environmental protection, the State Environmental Protection Administration (SEPA) led the first eco-industrial park (EIP) project in Guigang, Guangxi Zhuang Autonomous Region, in 2000. The site is a sugar complex formed in 1954 and is one of the largest sugar refineries, employing over 3800 workers (Geng Y, Haight M and Zhu Q, 2005). Figure 9 shows the empirical analysis of eco-industrial development in China.

Eco-industrial Parks in other countries

When successfully run, Europe’s industrial and technology parks play a key role in the urban economy, providing vital employment and a place for enterprise and innovation to flourish. Unfortunately, they can also be dreary, unfriendly places that suffer from problems such as poor environmental management, traffic congestion and pollution. These issues have a negative effect on people who work in industrial parks and live nearby. An EU-funded research project called ECOPADEV aims to give such areas a sustainable future by providing town planners with the tools they need to develop more eco-friendly industrial parks (Research and Innovation, 2012).

The United Nations Industrial Development Organization (UNIDO), in collaboration with the European Commission, held a dedicated side-session during Green Week 2014 on “Eco-Industrial Parks as a Tool to Scale a Resource Efficient and Circular Economy” (UNIDO and UNEP, 2014).

To promote the development of EIPs, the State Environmental Protection Administration of China (SEPA) initiated the pilot construction of eco-industrial demonstration parks in 1999 and established the Standard for the Construction and Management of Eco-Industrial Parks (on a trial basis) in 2006. As of January 2007, 24 national EIPs had been established throughout the country (Fang, 2008), this is indicated in Table 1 below. In 2007 fewer companies were into this EIP but it is increasing on a daily basis.

No.	Name
1	National Eco-Industrial Demonstration Park in Guigang (Sugar Industry)
2	Nanhai National Eco-Industrial Demonstration Park -- South China Environmental Protection Industrial Park
3	Baotou National Eco-Industrial Demonstration Park (Aluminum Industry)
4	Huangxing National Eco-Industrial Demonstration Park in Changsha
5	Lubei National Eco-Industrial Demonstration Park
6	National Eco-Industrial Demonstration Park in Tianjin Economic-Technological Development Area
7	National Eco-Industrial Demonstration Park of Fushun Mining Group
8	National Eco-Industrial Demonstration Park in Dalian Economic and Technological Development Area

9	National Eco-Industrial Demonstration Park in Suzhou High-tech Zone
10	National Eco-Industrial Demonstration Park in Suzhou Industrial Park
11	National Eco-Industrial Demonstration Park in Yantai Economic & Technological Development Zone
12	National Eco-Industrial Demonstration Base of Phosphorus-Coal-Based Chemical Industry in Kaiyang, Guiyang
13	National Eco-Industrial Demonstration Park in Weifang Ocean Chemical High-tech Development Zone
14	National Eco-industrial Demonstration Park in Shangjie District, Zhengzhou City
15	Baotou National Eco-Industrial Demonstration Park (Iron and Steel Industry)
16	Antai National Eco-Industrial Demonstration Park in Shanxi
17	Qingdao New World Eco-Industrial Park (Venous Industry)
18	National Eco-Industrial Demonstration Park in Zhangjiagang Free Trade Zone -- Yangtze River International Chemical Industrial Park
19	National Eco-Industrial Demonstration Park in Kunshan Economic and Technological Development Zone
20	National Eco-Industrial Demonstration Park in Fuzhou Economic and Technological Development Zone
21	National Eco-Industrial Demonstration Park in Wuxi New District
22	National Eco-Industrial Demonstration Park in Shaoxing Paojiang Industrial Zone
23	National Eco-Industrial Demonstration Park in Rizhao Economic Development Zone
24	National Eco-Industrial Demonstration Park in Shanghai Xinzhuang Industrial Park

Table 1: List of National EIPs (up to 2007 January) (Fang, 2008)

METHODOLOGY

Primary Data

The questionnaires were given to a number of industries, also a number of managers were interviewed, and further observations were done on a certain number of selected industries. The primary data was collected in a form of questionnaires for those industries that were interested, while further interviews and observations were done within these industries.

The study was conducted using both the qualitative and quantitative research. The overall number of the industries that were given survey questionnaires is 200 and. Researchers are still flying out more questionnaires to other companies within the park hoping to get more responses. Figure 2 illustrates the distribution of industrial parks that participated in the study. A majority of the industrial parks that participated are metal and maintenance industrial parks.

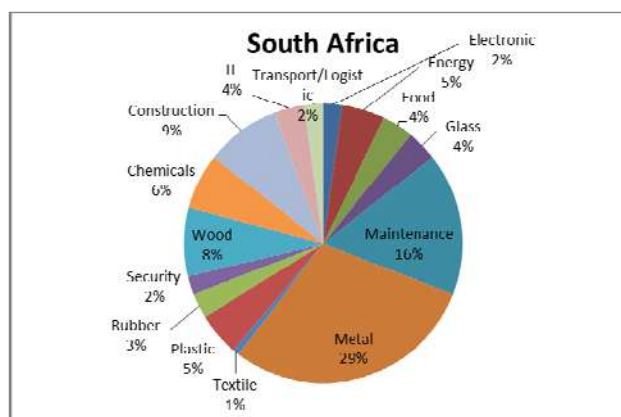

Figure 2: Distribution of Industrial Parks involved in the study.

The idea behind interviews was to find out what managers and supervisors of industries think about EIP, looking at the managers' perceptions and attitudes towards the idea. The answers given are more similar in a way that the study concludes that the managers need more knowledge through trainings and workshops on EIPs to realize the win-win situation for both environments and their own industries.

The survey questionnaire were analysed using the excel spreadsheet, the observations and interviews are used mostly on the recommendations.

Secondary Data

The secondary data for this study consisted of reviewing the literature, assessing the database for the industries that have already been visited in the past by other researchers and the past research reports that are from the same research. The importance of secondary data was to give the direction of the research, what has been done so far and what is it that still needs to be done in the project.

Data analysis

A preliminary study was conducted using the qualitative data analysis developed by O'Leary (2010); this method involved the following steps:

1. Reading through all of the transcripts carefully, and writing down ideas as they came to mind.
2. Wrote thoughts about each document, without focusing on the substance of the information but rather on the underlying meaning,
3. Made a list of all the topics, cluster together similar topics, formed these topics into columns that were arrayed as major topics, unique topics, and leftovers.
4. Abbreviated the topics as codes and wrote the codes next to the appropriate segments of the text. Checked if new categories of codes emerged.
5. Found the most descriptive wording for the topics and turned them into categories, then reduced the total list of categories by grouping topics that related to each other.
6. Made the final decision on the abbreviation for each category and alphabetised the codes.
7. Assembled the data material belonging to each category in one place and performed a preliminary analysis
8. Recorded the existing data.

This process enabled for further analysis, which was handled by Statkon.

STATKON

Statkon facilitated the design of questionnaires and the allocation thereof. The completed questionnaires were then captured and analysed for the purpose of the study. The information was analysed using the Statistical Package for the Social Science software (SPSS). SPSS is one of the most popular statistical packages which can perform highly complex data manipulation and analysis with simple instructions. It is designed for both interactive and non-interactive (batch) uses.

SPSS has scores of statistical and mathematical functions, scores statistical procedures, and a very flexible data handling capability. It can read data in almost any format (e.g., numeric, alphanumeric, binary, dollar, date, time formats), SPSS (2012). This software was used to analyse the data into information from the respondent's questionnaires.

RESULTS AND DISCUSSION

Waste Disposal

Waste disposal remains a key problem for industrial parks in South Africa. Figure 3 below depicts a zinc industrial park which disposes its scrap material by piling it on the yard. This type of disposal is dangerous to the workers and the vehicles within the yard as it has the potential of causing harm. This type of waste disposal also attracts criminal activities within the yard, as these scrap material can be sold at a scrap yard.



Figure 3: Zinc dipping scrap in Alrode Park

Municipalities and industries are thus in a difficult position, challenging them to find waste management practices alternative to incineration. Waste reduction and minimization efforts need to be increased and the problem clearly calls for going a step further by initiating an industrial ecology approach. Therefore, it can be concluded that sustainable development is not a concept that only concerns environmentalists and policy makers, but should be embraced by industries, the business community, and society as well (Haggar, 2007).

Limited Resources

Due to limited resources, a majority of industrial parks in South Africa companies build in prohibited areas, as indicated in figure 4. This is caused by the lack of land availability as one of the limited resources in South Africa. These parks that consume prohibited land are mostly unaware that they are prohibited to use the specific land, and build the parks on landfills and under high transmission electricity power lines. South Africa currently consumes million tons of natural resources every year and imports million tons from overseas. As such there is a general growing concern that as resources and space for landfill become more scarce and waste disposal costs increase, further economic growth may be hampered by growing resource inefficiencies.



Figure 4: Industries trying to build under high transmission electricity power lines in Alrode (captured by researchers)

Air Pollution and CO2 Emissions reduction

Research is imperative when one considers the current concerns on climate change; the construction of low carbon industrial parks is emphasized to favour the development of low carbon economy in South Africa. Low carbon industrial park is an updated EIP with carbon emission control taken into consideration. The establishment of low carbon industrial park aims at minimizing the carbon emissions and environmental impacts while maximizing the economic output. This involves low carbon building, low carbon lifestyle, preferable environment and high economic efficiency. According to the Kyoto Mandate, countries have reduced its CO2 emissions (Anderson, 1998). As the largest source of CO2 emissions in South Africa, industry must play a significant role in CO2 reduction. The list below details the environmental benefits of implementing Eco- Industrial Parks, specifically in South Africa;

- Reduction of air pollution
- Reduction of soil pollution
- Reduction of volume and load of waste water discharges and pollution of ground and surface waters
- Reduction of water consumption
- Reduction of energy use through energy efficiency,
- energy recovery and use of renewable energy
- Reduction in solid and hazardous waste
- Reduction of product losses
- Creation of green space in and around the industrial park
- Reuse, recycling and recovery of waste
- Water conservation through planting of drought resistant plants

Social and Economic benefits

The social benefits of eco-industrial parks are Cleaner air and cleaner water which would lead to better health. Furthermore the development of Eco-industrial parks would lead to a decreased demand on the sewer system and less waste disposed to landfills.

Economic benefits of Eco-industrial parks, as indicated in Table 2, include decreased production costs due to the purchasing of unwanted by-products from other businesses at bargain prices and selling of by-products produced, reduced energy consumption in relation to less transportation used, decreased waste management based on on-site businesses being able to sell what would be regarded as waste, decreased Costs of compliance and Cost of Research and Development as these costs would be shared with other companies.

Direct employment creation and income generation	Foreign direct investment	Reduced resource costs	Avoidance of regulatory penalties due to waste charges
Export growth and export diversification	Government revenues	More efficient material use	Increase in income per capita
Foreign exchange earnings	Increased competitiveness of companies	Increased sales through green marketing and image	Meeting customers' requirements
Reduced costs for waste management	Reduced energy costs	Reduced costs of water consumption	Reduced costs for transportation
Access to investment capital	Access to environmental credit lines		Access to environmental certification

Table 2: Economic benefits of Eco-Industrial Parks

RECOMMENDATIONS

Currently in South Africa, environmental protection is ignored at the expense of economic development (Haggard 2007). With sustainable development and design this does not have to be the case. Sustainable development looks to lower costs and improve the environment simultaneously.

South Africa's future should be more focused on industrial symbiosis as China is emphasising on currently. With regard to political support, China's central government has played a key role in encouraging EID. As the national agency on environmental protection, the State Environmental Protection Administration (SEPA) led the first eco-industrial park (EIP) project in Guigang, Guangxi Zhuang Autonomous Region, in 2000. The site is a sugar complex formed in 1954 and is one of the largest sugar refineries, employing over 3800 workers (Geng Y, Haight M and Zhu Q, 2005). Figure 5 shows the empirical analysis of eco-industrial development in China.

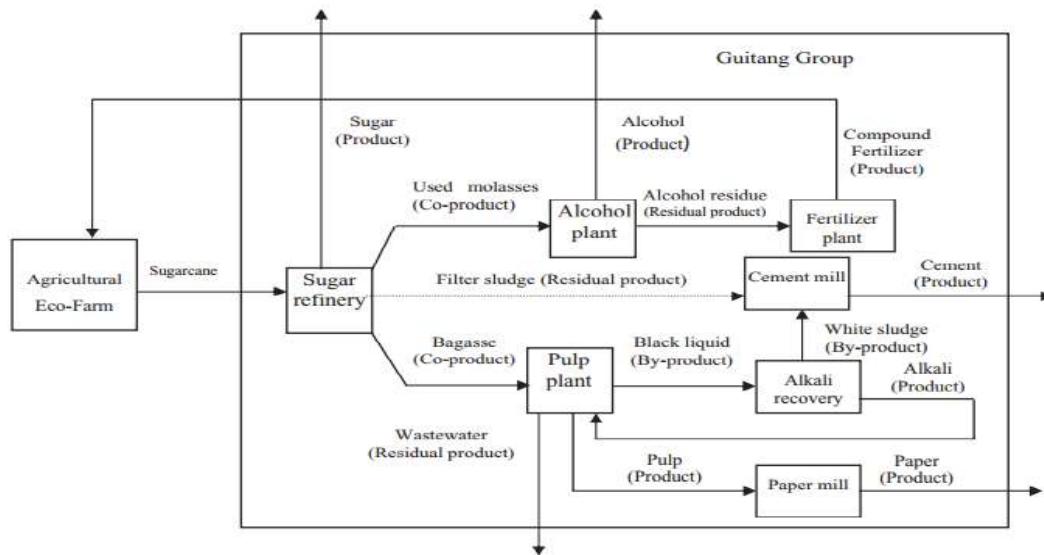

Figure 5: Empirical analysis of eco-industrial development in China. (Geng Y, Haight M and Zhu Q, 2005).

Industrial symbiosis is often referred to in terms of synergies, which also appears in the definition by (Chertow, 2000). There are two types of synergies that have direct effects on the involved entities. The first type is the by-product synergy that involves the use of a previously unused or undervalued by-product as an input material in another facility. This can reduce waste and the extraction of virgin materials as well as add economic value to the by (Centre of Excellence in Cleaner Production (CECP), 2007). The second is the utility synergy where companies share utility infrastructure such as the production of energy, the handling of process water or joint waste and emissions treatment. Utility synergies can lead to economic savings due to the economy of scale (Centre of Excellence in Cleaner Production (CECP), 2007). When utility services are outsourced, it allows for the companies to focus on core business, while utilities are handled by expertise in that area. A third synergy that is normally considered business as usual is the supply synergy among collocated customers and suppliers. It means no or short transport distances (Centre of Excellence in Cleaner Production (CECP), 2007). Industrial symbiosis among actors can also lead to spin off effects. On a regional level, it can strengthen the co-operation between different actors, both public and private (Burström, F. & Korhonen, J, 2001). It has also been known to benefit environmental innovation, and there is room for new niche industries that fill the gaps between other industries in processing by-product for example (Centre of Excellence in Cleaner Production (CECP), 2007) and (Mirata, 2005). That would further increase the regional economy in creating new jobs. Industrial symbiosis has also been used as a marketing argument by regional and local authorities to attract and retain new businesses in the region (Lombardi, R. & Laybourn, P, 2012). Companies should have an Industrial symbiosis whereby one waste of another is an input for the other. Figure 6 shows the operations at a company giving others resources as raw materials.

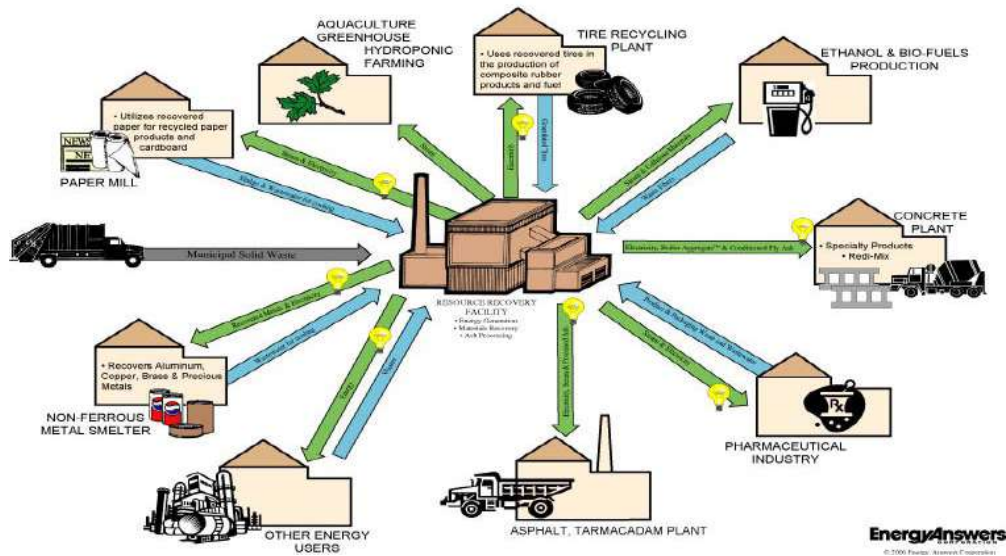

Figure 6: Energy Based Recovery Eco-Industrial Park, (Energy Answers, 2014).

The benefits Eco-Industrial Parks provide may serve as incentives for companies to improve their environmental performance in terms of management of materials, energy and waste. The potential they offer in terms of local development is already encouraging communities to invest in concepts incorporating this approach to industrial development (Fleig, 2000).

CONCLUSION

Researchers have identified a number of barriers that need to be overcome to facilitate the adoption of industrial ecology in South African institutions, and on-going regional case studies could lead to solutions that will overcome these barriers. The role of economic development officials and researchers should be to promote policies that will remove the obstacles to the recovery of industrial resources, and to educate the public and private sectors as to the benefit of industrial symbiosis. As such, more emphasis should be on the development of mechanisms that would more effectively encourage individual companies to manage waste streams effectively while leaving them the necessary freedom to develop new and profitable uses for by-products.

REFERENCES

- Anderson, B. (1998). *The Kyoto Protocol on Climate Change*. Japan: Resources for the Future.
- Burström, F. & Korhonen, J. (2001). *Municipalities and industrial ecology: Reconsidering municipal environmental management*. USA: Sustainable Development.
- Centre of Excellence in Cleaner Production (CECP). (2007). Regional resource synergies for sustainable development in heavy industrial areas. Perth: Curtin University of Technology.
- Chertow, M. (2000). *Industrial Symbiosis: Literature and Taxonomy*. USA: Annual Review of Energy & the Environment.
- Deutsche, W. (2015). *Environment*. Retrieved March 28, 2016, from Eco parks offer firms a low-carbon road to growth: <http://www.dw.de/eco-parks-offer-firms-a-low-carbon-road-to-growth/a-6532982>
- Energy Answers. (2014). *Recovery Based Eco Industrial Park*. Retrieved November 23, 2016, from Eco-Industrial Park: http://www.energyanswers.com/development/sustainable_development/eco_industrial_park.php
- Fang, Y. (2008, August 26). *The Encyclopaedia of the Earth*. Retrieved March 28, 2016, from Eco-industrial parks in China: <http://www.eoearth.org/view/article/151922/>
- Fleig, A. (2000). *A Strategy towards Industrial Ecology in Developing and Newly Industrialised Countries*. Germany: Deutsche Gesellschaft für Technische Zusammenarbeit (GTZ) GmbH.
- Geng Y, Haight M and Zhu Q. (2005). Empirical Analysis of Eco-Industrial Development in China. *Sustainable Development*, 1-13.
- Haggard, P. (2007). Cradle-to-cradle for Sustainable Development. *Sustainable Industrial Design and Waste Management, Elsevier*, Pages 21–84.
- Lombardi, R. & Laybourn, P. (2012). *Outcomes of IWCAIS: Positive Action for Green Growth. Summary Report from the first International Working Conference on Applied Industrial Symbiosis*. Birmingham, United Kingdom: International Synergies Limited.
- Mirata, M. (2005). *Industrial Symbiosis A tool for more sustainable regions?* Lund: The International Institute for Industrial Environmental Economics.
- O’Leary, Z. 2010. *The essential guide to doing your research project*. Singapore. SAGE publications Asia-Pacific Pty. Ltd.
- Smart Communities Network. (2005, January 18). Sustainable Business. Retrieved March 28, 2016, from Sustainable Business: <http://www.smartcommunities.ncat.org/business/ecoparks.shtml>
- SPSS software. 2012. *Predictive analytics software and solutions*. <http://www-01.ibm.com/software/analytics/spss/> . Last accessed 18 September 2016.

THE EFFECT OF GLOBAL MINDSET ON LEADERSHIP BEHAVIOR

Vânia Maria Lima Neves and Patrícia Amélia Tomei
Pontifical Catholic University of Rio de Janeiro, Brazil

ABSTRACT

Global mindset, defined as the ability of leaders to influence individuals, groups and organizations to adjust to different environments and cultures internationally through openness to and awareness of diversity across cultures and markets, has been described as a critical factor for organizational development. The study of Konyu-Fogel (2011) among American business leaders indicated that six factors (number of foreign languages spoken, being raised by/living in a bilingual/multiethnic family, number of countries worked in, percentage of employees working overseas, percentage of revenue from foreign operations, and location/country of employment) significantly increased the global mindset. In order to identify factors that affect the mindset of leaders in different cultural contexts, an on-line survey based on Konyu-Fogel's (2011) model was applied to a sample of 163 leaders who work in positions that require international activities in organizations in 22 economic segments in Africa, Asia, South and North America, Europe and the Middle East. The results indicate that global mindset is responsible for 39.1% of the variability of leadership behavior, confirming previous studies which have identified that global leaders with high global mindset are more likely to exhibit leadership behaviors with understanding of differences across cultures and countries in response to the global environment. Specifically related with demographic factors such as age, gender, number of foreign languages spoken, number of countries worked in and being raised/living in bilingual/multiethnic family, the results show that they do not affect the global mindset score, unlike the factors place of employment and position. Finally, regarding organizational factors that affect global mindset, the influence of total number of employees, percentage of employees working abroad and location/country of headquarters on the global mindset score was weak. On the other hand, products lines and percentage of revenue from foreign operations significantly affects business leaders' global mindset.

Keywords: Global leadership; Global mindset; Leadership behavior.

INTRODUCTION

Today's globalized economy stands apart in many respects from previous international commercial arrangements, creating new business realities that must be recognized by organizations and their managers. The imperatives of globalization apply to the majority of economic sectors, affecting firms at all hierarchical levels of the management chain (Jeannot, 2000).

Recent decades have been marked by profound transformation throughout the world stimulated by globalization. The magnitude of these changes has had economic, social and cultural impacts in virtually all countries. In a recent survey of 500 executives of 100 organizations, the Economist Intelligence Unit reported that 75% of these firms planned to compete in foreign markets (Unit, 2010).

One of the consequences of globalization is that firms need leaders who have the ability to integrate various viewpoints to manage production, marketing and delivery of value effectively on a global scale (Jeannot, 2000). The

worldwide challenge is not only to prepare the future labor force, but to do so in a way that preserves the role of higher education in focusing minds on the bigger picture (Global Risk Report, 2014).

Global mindset, a set of attributes and traits that help leaders influence individuals, groups and organizations anywhere in the world (Javidan & Bowen, 2013), has been described as a factor for the development and success of global leadership (Cohen, 2010; Javidan & Bowen, 2013; Javidan & Walker, 2013). Successful business strategies should start with transformations in cognitive global managerial mindsets (Aggarwal, 2011).

Leaders with a global mindset have a broad view, a global orientation toward business, and are adaptable to local cultures and settings (Story & Barbuto, 2011). According to a survey of 138 executives of multinationals in global leadership positions, the level of leadership behavior that is critical for the performance of an organization can increase when the global mindset is stronger (Konyu-Fogel, 2011). This analysis, focused on American leaders, needs to be expanded to examine the effect of global mindset in larger samples and different industries/countries, to provide more data for firms to develop their global leaders.

This the objective of this work: to expand on the study of Konyu-Fogel (2011) and investigate the effect of global mindset on the leadership behavior in a sample of global leaders of multinational and national firms with operations in Africa, Asia, South America, North America, Europe and the Middle East.

THEORETICAL FRAMEWORK

Global Leadership and Global Mindset

There is no consensus on the definition of global leadership with respect to rigor, precision and scope. The approach varies regarding the boundaries of the designation “global leader”. Mendenhall et al. (2012) analyzed three critical dimensions involving the contextual, relational and temporal-spatial elements of the construct: (a) complexity of the operation and residency; (b) boundaries inside and outside the organization; and (c) degree of geographic placement. They stressed that global leadership is related to a process that influences others to adopt a shared vision in a context characterized by significant levels of complexity, flow and presence.

According to Mathews (2016) “*global leadership entails the interrelationships that exist among the endogenous and the exogenous process of influencing and being effective in the context of global business operations and management characterized by heterogeneity and complexity*” (Mathews, 2016, p. 42).

Many researchers have contributed their visions to the literature on the competencies of global leadership – the personal qualities, skills, values and traits that are essential to perform the activities that are required for leaders to operate beyond national frontiers in complex global environments (Beechler & Javidan, 2007; Gundling et al., 2011; Cumberland et al., 2016; Kim & McLean, 2015) – and the behavior of global leadership, meaning the set of attitudes that prize sharing of information and experience across national, functional and business frontiers, to balance the competition of functional, business and national priorities that emerge in the globalization process.

According to Morley and Cerdin (2010), the competencies for global leadership are related to the ability to perform effectively in situations of different cultures. To be successful in the international operational setting, global leaders need to be able to sense and interpret changes in dynamic and complex environments, integrate multiple strategies and capitalize on the advantages inherent to their firms’ position in the global market (Bartlett & Beamish, 2014, Miska & Öner, 2015).

An important competency of global leaders is cultural intelligence (Earley & Mosakowski, 2004), which favors recognition and understanding of the various cultural dimensions and culturally acceptable behavior patterns between cultures (Dorfman et al., 2012). Making decisions in complex settings and the ability to read cultural nuance and adapt the leadership style accordingly have been indicated as keys to the success of global leaders (Javidan & Bowen, 2013).

According to Konyu-Fogel (2011), although the literature indicates a huge list of competencies for effective global leadership, it is not possible to identify a common hierarchy of competencies or behaviors for global leaders. Further according to her, the prescriptive listing of global competencies can overlook the complexity of the phenomenon of leadership, so various factors of global leadership behavior should be explored through empirical studies to help shed light on the relationship between global mindset and leadership behavior.

Global mindset can be called an essential feature of leadership in the twenty-first century that requires people to think globally and understand the challenges and opportunities (Javidan & Walker, 2013).

Table 1 presents some of the main definitions in the literature for global mindset, demonstrating that despite the diversity of views of researchers, the concepts encompass personal qualities or philosophies, knowledge, skills and behaviors in various combinations (Ananthram & Nankervis, 2014).

Table 1: Definitions and concepts of global mindset

Authors	Description
Lovvorn & Chen (2011)	Emotional and cultural intelligence that appreciates cultural diversity.
Konyu-Fogel (2011)	Intellectual intelligence (ability to differentiate and integrate information) and cultural intelligence (cognitive framework for organizing and understanding cultural cues to adapt and dictate leadership behavior in different cultural settings).
Osland et al. (2012)	Global mindset is a cognitive structure composed of two constructs, cosmopolitanism and cognitive complexity.
Javidan et al. (2013)	As set of attributes and traits that help global leaders to better influence different individuals, groups and organizations, with three main dimensions: intellectual capital, psychological capital and social capital.
Story and Barbuto (2011); Story et al. (2014).	The combination of having high scores on cultural intelligence and global business orientation represents global mindset in our proposed framework. Thus, a global mindset is that of individuals who have a global business orientation and are adaptable to the local environment and culture.

Source: based on Maike & Franziska (2017), adapted by the authors.

No consensus exists among researchers as to how a global mindset is acquired. Some suggest it is innate, while others argue that it is developed with regular global experience over time (Bouquet et al., 2009). Although some global mindset characteristics are considered genetic, it can be developed by socialization, like an evolutionary process constructed through feedback mechanisms that expand a person's mental horizons (Lovvorn & Chen, 2011), promoting a change of managerial mentality (Fatehi & Ghadar, 2014).

Global Mindset and Leadership Behavior: Model of Konyu-Fogel (2011)

Konyu-Fogel (2011) conducted a survey with a sample of 138 global leaders working for firms of the Fortune Global 500 and Forbes Global 2000, based on three categories: demographic and organizational factors; global mindset; and leadership behavior. Global mindset was operationalized with the constructs (1) intellectual intelligence (ability to differentiate and integrate information), composed of differentiation, integration, management of uncertainty, recognition of patterns and global thinking; and (2) cultural intelligence (cognitive framework for organizing and understanding cultural cues to adapt and dictate leadership behavior in a given context), defined as openness to learning, emotional sensitivity, flexible behavior and understanding of cultural differences. Finally, leadership behavior refers to actions for planning, coordination, leadership, communication, collaboration and motivation of people.

Konyu-Fogel (2011) found that global mindset was significantly related with four demographic factors, suggesting a direct and positive relationship of global mindset score and the number of countries worked in/conducted business with, number of foreign languages spoken, being raised by/living in a bilingual/multiethnic family, and location/country of employment. She also identified a significant relationship of global mindset with two organizational factors, suggesting a direct and positive relationship of global mindset score with percentage of employees working abroad and percentage of revenue from foreign operations. Overall, the results confirmed the significant effect of global mindset on leadership behavior.

Konyu-Fogel (2011) concluded that the development of a global mindset is likely influenced by multiple factors involving personal, educational and professional experiences, and that involvement of family, education, government and global organization are important in the development of global mindset and global leadership skills.

METHODOLOGY

This study can be classified as quantitative, based on statistical data obtained from a structured questionnaire administered to a random sample. The universe was leaders of multinational or national firms holding positions requiring leadership of businesses, activities or teams with international scope in 22 economic segments.

The sample surveyed was constructed based on our contacts. All told, 300 executives living and working in Africa, Asia, Europe, North America and South America were invited to participate in the study.

These people received an invitation letter via email explaining the purpose of the study, with assurance of anonymity, and a link to the questionnaire for online response. From 163 respondents, the final sample consisted of 136 participants who completed the questionnaire with sufficient data for use. Their positions were variously owner/president, chief executive officer (CEO), chief information officer (CIO), chief operating officer (COO), vice-president, executive director of marketing, recruitment partner, management consultant, senior manager, program/project manager, manager, senior engineer and educator/training specialist.

We used the questionnaire developed by Konyu-Fogel (2011) as part of her doctoral thesis. The first section of the questionnaire is composed of 13 items related to demographic and organizational factors, used to identify which of these factors can influence/increase the global mindset score. The second is composed of 16 items for classification of attitudes and perceptions related to global mindset, on a Likert of 1-5. The complete scale is obtained by the average of the values of each of the 16 items of the global mindset scale. The third section of the questionnaire is composed of 20 items for classification of the respondents regarding their perceptions about the six dimensions of leadership behavior, on a Likert of 1-5.

The following hypotheses were tested:

H₁: Demographic factors influence the global mindset of business leaders.

H₂: Organizational factors influence the global mindset of business leaders.

H₃: The global mindset of business leaders affects their leadership performance in activities that are critical for organizational performance.

The complete global mindset scale is the combined score of the intellectual intelligence of the leader (composed of ability to differentiate, integrate and manage uncertainty, recognize patterns and think globally, and cultural intelligence (composed of openness to learning, emotional sensitivity, flexible behavior and understanding of other cultures) (Konyu-Fogel, 2011).

Finally, the complete leadership behavior scale is the combined score of the six dimensions of leadership behavior: planning, coordinating, leading, communicating, motivating and collaborating between cultures and countries to attain global objectives (Konyu-Fogel, 2011).

FINDINGS

No statistically significant relation was found between age and gender, since the p-value was 0.1099. The organization factor economic segment and demographic factor position held had statistically significant associations with global mindset, with the economic segment factor having overall p-value of 0.0008, the most significant segments being management consulting (p-value=0.0326) and R&D (p-value=0.0143).

With respect to demographic information, was found a statistically significant association of place of work with global mindset, with p-value equal to 0.0427. The bilingual family variable just missed the significance cutoff in the ANOVA, with p-value of 0.0572.

Therefore, since at least one of the demographic factors had a significant effect on global mindset, the null hypothesis H₀₁ was rejected and H₁ was accepted, suggesting that the global mindset of the leaders surveyed is significantly affected by the place of work.

Additionally, when performing regression of the dependent variable global mindset on the independent variables referring to the demographic and organizational factors, followed by stepwise regression analysis, global mindset was significantly associated with the variable position held, and the significance of the variable place of work found in the ANOVA was confirmed. Therefore, based on this regression test, the global mindset of the leaders is also significantly affected by the demographic factor position held.

With respect to the organizational information, all the organizational factors were considered to be independent variables in an ANOVA model, for multivariate assessment of the effect of these factors on the dependent variable global mindset. The ANOVA did not show statistically significant association of global mindset with any of the organizational factors, since the p-value was higher than 0.05 for all the variables. Based on this result, the null hypothesis H₀₂ was accepted, suggesting that the global mindset of the leaders is not significantly affected by the organizational factors.

The regression of the dependent variable global mindset on the independent variables referring to the demographic and organizational factors, followed by stepwise regression analysis, revealed that the variables economic segment and percentage of revenue from abroad had statistically significant associations with global mindset, with p-value lower than 0.05. Therefore, the null hypothesis H₀₂ was rejected and H₂ accepted, suggesting that the global mindset of the leaders is significantly affected by the organizational factors economic segment and percentage of revenue from abroad.

We found a statistically significant effect of global mindset on leadership behavior, with p-value less than 0.0001 and estimated parameter of positive 0.91. Therefore, the null hypothesis H₀₃ was rejected and H₃ accepted, indicating that leaders with global mindset score are more likely to have behaviors that demonstrate higher levels of

skills in global planning and coordination and strong ability to lead, motivate and collaborate between cultures and countries to achieve global activities.

DISCUSSION

To answer the central question, we first analyzed the effects of the demographic factors on global mindset and then the effects of global mindset on leadership behavior.

With respect to age, as also found by Javidan et al. (2009), leaders with age older than 60 years had the highest global mindset score (GM = 3.95). In contrast to the findings of Konyu-Fogel (2011), who identified that leaders with the lowest global mindset score were in the 26-36 year age bracket, and Javidan et al. (2009), who found the lowest global mindset score among leaders with age from 20-29 years, in this study the leaders with age range of 47-59 years had the lowest global mindset score (GM = 3.82).

In relation to the number of languages spoken, no significant relation was found with the global mindset score, but the highest global mindset score was found for the factor “three or more foreign languages” (GM=4.04). On the other hand, the factor “no foreign language” was associated with the second highest global mindset score. Of the 17 individuals who reported this factor, 94% work in the same region as the parent company, which suggests these are individuals from countries whose native language is English.

Regarding the factor of being raised in a bilingual/multiethnic family, this factor was not significant with respect to the overall score. This result diverges from findings of previous studies of the importance of experience in a bilingual/multiethnic environment and the influence of family background on global mindset and that growing up in a bicultural family can be an asset.

With respect to the number of countries where the respondents previously worked or conducted business, no significance was identified with global mindset. This result again diverges from previous studies that have concluded that international travel/work, cultural immersion by living abroad and involvement in global operations tend to increase the global mindset score (Javidan et al., 2009 Nummela et al., 2004; Crowne, 2013).

Regarding the place of current work, the results indicate a significant influence on global mindset. In our sample, 50% work in South America, 18% in Europe and 13% in the USA. Place of work was also found to be significant factor in relation to global mindset by Konyu-Fogel (2011). The differences found in our study can be related to the development of cultural intelligence from international experiences (Lovvorn & Chen, 2011). However, it is important to consider that the place of employment does not necessarily indicate nationality. Thus, conclusions on the relation of nationality and global mindset are matters for future research.

With regard to the hierarchical position, this study identified a significant effect on global mindset. The highest global mindset score was found for the position recruitment partner (GM=4.56), followed by CEO (GM=4.38), marketing executive (GM=4.15) and vice-president (GM =4.00). This result diverges from that of Konyu-Fogel (2011), who found that the respondents in the positions of vice-president and CEO had the highest global mindset scores, respectively. On the other hand, this result agrees with that of Javidan and Walker (2013), who stated that HR professionals should be prepared to lead efforts for internationalization and integration so as to have an exceptional and genuine impact on their firms, by developing their global mindset as a priority.

We did not find any significant effect of employment level on global mindset, although the tendency was for respondents from larger firms to have higher global mindset scores. This contrasts with the conclusion of Konyu-Fogel (2011), who found the highest global mindset score among respondents from firms having fewer than 500 employees. But the result corroborates the findings of Jeannet (2000) and Bartlett and Beamish (2014), that organizations having a large number of employees and involved in global business dealings have leaders with higher global mindset, since this helps in developing global strategies and skills with capacity for local response.

We did not find a significant relation of the number of countries of operation and global mindset, or any uniform pattern linking larger firms with greater global mindset. This result is in line with that of Jeannet (2000), who found that firms that operate in various countries do not necessarily have leaders with stronger global mindset. Bartlett and Beamish (2014) also stated that companies that operate in multiple countries can use distinct strategies: ethnocentric (domestic/national); polycentric (multiple differentiation); regiocentric (based on regional integration and coordination); or geocentric or transnational (global). Depending on the need of the local operations and the scope of the activity, the (domestic) leaders do not need to have as strong a global mindset as leaders in charge of global activities (Javidan & Walker, 2013).

We did not find any significant effect of headquarters location with global mindset, suggesting that this trait of leaders is not affected by the country where the parent company is located. On the other hand, the results indicated a significant variation of global mindset of the leaders within the regions analyzed. Therefore, future studies with larger samples are necessary to investigate these aspects.

Finally, we found a significant effect of global mindset on leadership behavior: it is responsible for more than 39.1% of the variability of this behavior, meaning a direct and positive relationship exists between leadership behavior and global mindset, also suggesting according to the previous analyses that it is influenced by demographic and organizational factors.

These results corroborate those of previous studies indicating that effective global leaders demonstrate an understanding of the differences between cultures and countries when carrying out complex activities in global settings (Rhinesmith, 2003). In the global environment, leaders are faced with various challenges and opportunities, and must engage in complex planning and coordination, develop skills to mobilize, motivate, lead and energize people, and seek collaboration and communication to attain sustainable competitive advantage and high performance (Konyu-Fogel, 2014). According to Konyu-Fogel, human resources practices should focus on providing support to the firm's strategy and focus on developing leaders that can help the firm attain this sustainable competitive advantage (Konyu-Fogel, 2013).

FINAL CONSIDERATIONS

Companies in general appear not to be sufficiently prepared to develop leaders with the skills necessary to act effectively in the international business scenario (Mendenhall et al., 2013). It is important to mention that the definition of global leader is not restricted to top executives. Any person who leads efforts for global change in the public or private sector (national or multinational), including nonprofit organizations, is a global leader (Javidan & Walker., 2013; Mendenhall et al., 2013).

Various researchers have stated that having a global mindset is a key characteristic for the development of leadership. In this respect, this study corroborates previous findings that global mindset affects leadership behavior. Based on the definitions in the literature reviewed and our results, we recommend that organizations that are active globally and need to maintain or enhance their competitive advantage in their market strengthen their leadership development programs, measuring the global mindset at all levels of the management chain where people are involved in activities with global interface or responsibility. This will enable focusing actions to develop leadership more strategically.

REFERENCES

- AGGARWAL, R. (2011) Developing a global mindset: Integrating demographics, sustainability, technology, and globalization. *Journal of Teaching in International Business*, 22(1), 51-69.
- ANANTHRAM, S.; NANKERVIS, A. R. (2014) Outcomes and Benefits of a Managerial Global Mindset: An Exploratory Study with Senior Executives in North America and India. *Thunderbird International Business Review* v. 56, n. 2, 193-209.
- BARTLETT, C. A., BEAMISH, P. W. (2014) *Transnational management: text, cases, and reading in cross-border management*. (Seventh edition). Singapore.
- BOUQUET, C., MORRISON, A., BIRKINSHAW, J. (2009) International attention and multinational enterprise performance. *Journal of International Business Studies*, 40(1), 108-131.
- CLAPP-SMITH, R., WERNISING, T. (2014) The transformational triggers of international experiences. *Journal of Management Development*, 33(7), 662-679.
- COHEN, S. L. (2010) Effective global leadership requires a global mindset. *Industrial and Commercial Training*, 42(1), 3-10.
- CROWNE, K. A. (2013) Cultural exposure, emotional intelligence, and cultural intelligence: An exploratory study. *International Journal of Cross Cultural Management*, 13(1), 5-22, April.
- CUMBERLAND, D. M.; Herd, A; ALAGARAJA, M; KERRICK, S.A. (2016) Assessment and Development of Global Leadership Competencies in the Workplace. *Advances in Developing Human Resources*. Aug, Vol. 18 Issue 3, p301-317. 17p
- DORFMAN, P., JAVIDAN, M., HANGES, P., DASTMALCHIAN, A., HOUSE, R. (2012) Globe: A twenty-year journey into the intriguing world of culture and leadership. *Journal of World Business*, 47(4), 504–518, October.
- EARLEY, P. C., MOSAKOWSKI, E. (2004) Cultural intelligence. *Harvard Business Review*, 82(10), 139-146.
- FATEHI, K., GHADAR, F. (2014) A measure of international managers' mindset. *International Journal of Commerce and Management*, 24(4), 321-333.
- GUNDLING, E., HOGAN, T., CVITKOVICH, K. (2011) *What is global leadership*. Nicholas Brealey. US.
- JAVIDAN, M., BOWEN, D. (2013) 'Global Mindset' of managers. *Organizational dynamics*, 42(2), 145.
- JAVIDAN, M.;HOUGH, L., BULLOUGH, A. (2009) Conceptualizing and measuring global mindset: development of the global mindset inventory. Glendale, AZ.
- JAVIDAN, M.;WALKER L., J. (2013) *Developing Your Global Mindset: The Handbook for Successful Global Leaders eBook: Mansour Javidan, Jennie L Walker [Kindle Edition]*. Edina, MN: Beaver's Pond Press, Inc.
- JEANNET, J. (2000) *Managing with a global mindset*. London: Pearson Education.
- KIM, J.; MCLEAN, G. (2015) N. An integrative framework for global leadership competency: levels and dimensions *Human Resource Development International*. Jul, Vol. 18 Issue 3, p235-258. 24p.
- KONYU-FOGEL, G. (2011) Exploring the effect of global mindset on leadership behavior: An empirical study of

business leaders in global organizations. ProQuest Dissertations and Theses, Lawrence Technological University, Ann Arbor.

KONYU-FOGEL, G. (2013) Global skills and competency training for developing global talent: implications for international human resource management. *Journal of the North American Management Society*, 7(1), 13.

KONYU-FOGEL, G. (2014) 21st Century sustainable competitive advantage: critical capabilities through leadership and organizational development. *Economics and Culture Scientific Journal*, Riga, Latvia, 10 (1), 29-46.

LAROCHE, M., PONS, F., RICHARD, M. (2009) The role of language in ethnic identity measurement: a multitrait-multimethod approach to construct. *The Journal of Social Psychology*, 2009, 149(4), 513–539. Heldref Publications.

LOVVORN, A. S., CHEN, J.-S. (2011) Developing a global mindset: The relationship between an international assignment and cultural intelligence. *International Journal of Business and Social Science*, 2(9), 275-283.

MAIKE A.; FRANZISKA B (2017) A systematic literature review on the definitions of global mindset and cultural intelligence – merging two different research streams. *International Journal of Human Resource Management*. Jan, Vol. 28 Issue 1, p170-195. 26p.

MATHEWS, J.I.(2016) Toward a Conceptual Model of Global Leadership. *Journal of Organizational Behavior*. Apr2016, Vol. 15 Issue 2, p38-55. 18p.

MENDENHALL, M. E., OSLAND, J. S., BIRD, A. ODDOU, G. R., MAZNEVSKI M. L., STEVENS, M.J., STAHL, G. K. (2013) *Global leadership: research, practice and development*. New York: Taylor & Francis.

MENDENHALL, M. E ;REICH, B. S., OSLAND, J. S., BIRD, A. (2012) Defining the “global” in global leadership. *Journal of World Business*, 47(4), 493–503, October.

MISKA, C.;ÖNER, H.(2015) Global Leadership Practices: A Cross-Cultural Management Perspective. *Academy of Management Learning & Education*. Dec2015, Vol. 14 Issue 4, p655-657. 3p.

MORLEY, M. J., CERDIN, J. L. (2010) Global management competencies: a theoretical foundation. *Journal of Managerial Psychology*, 25(8), 829-844

OSLAND, J.S., BIRD, A., MENDENHALL, M. (2012). Developing global mindset and leadership capabilities. In G. K. Stahl, I. Björkman, & S. Morris (Eds.), *Handbook of research in international human resource management* (2nd ed., pp. 220–252). Cheltenham: Edward Elgar.

PAUL, K., MEYSKENS, M., ROBBINS, S. (2011) Components of a global mindset: corporate social responsibility and cross-cultural sensitivity. *Journal of International Business and Cultural Studies*, 5(1).

PUCK, J. F., KITTLER, M. G., WRIGHT, C. (2008) Does it really work? *International journal of human resource management*, 19(12), 2182-2197.

STORY, J. S. P., BARBUTO, J. E., LUTHANS, F., BAVAIARD, J. A. (2014) Meeting the challenges of effective international HRM: Analysis of the Antecedents of Global Mindset. *Human Resource Management*, 53(1), 131-155.

STORY, J. S. P., BARBUTO, J. E. (2011) Global mindset: a construct clarification and framework. *Journal of Leadership & Organizational Studies*, 18(3), 377-384.

UNIT, E. I.(2010) "Global firms in 2020: The next decade of change for organizations and workers." Retrieved January, 20.

IMMEDIATE MANAGER, PERFORMANCE EVALUATION AND EMPLOYEE ENGAGEMENT: GAME CHANGER FOR ORGANIZATIONAL PERFORMANCE?

Hester Nienaber
University of South Africa (Unisa), South Africa &
Northern Arizona University, U.S.A.

ABSTRACT

This paper reports on a study investigating employee engagement, with specific reference to the dimension 'immediate manager'. Data were collected by electronic survey from 4,099 respondents. The regression analysis showed that the immediate manager explains 52.1% of variation in employee engagement, while the item relating to performance evaluation scored the lowest of all items making up this dimension. The findings are significant because they confirm the vital role of the immediate manager in ensuring organizational performance, which can be leveraged by interpersonal relationships, especially political skills. The contribution stems from integrating strategy, employee engagement and performance management theory, which has not been done before.

Keywords: Employee engagement, immediate manager, organizational performance, performance evaluation, strategy.

INTRODUCTION

Organizational performance (i.e. goal achievement) has been under scrutiny for a long time and from different perspectives, because realized performance falls short of planned performance. Generally, this performance gap is attributed to the breakdown in strategy implementation (Cocks, 2010; Mankins & Steele, 2005; Skivington & Daft, 1991; Van der Merwe & Nienaber, 2015), the tool organizations use to achieve their goals (Grant, 2016). Various reasons are advanced for strategy implementation failure, ranging from the disconnection between strategy and performance management (Micheli & Mura, 2017) to the unavailability of employees with the right competence (knowledge, skills, experience, attitudes, health and well-being) (Cheese, Thomas, & Craig, 2008; Fegley, 2006; Lockwood, 2007; Mankins & Steele, 2005), to implement strategy. Strategy implementation constitutes the daily work of employees (Jarzabkowski & Spee, 2009), which is facilitated by leadership down the line. Some researchers have shown that strategy has not been designed to be implementable (Cocks, 2010) while others have been arguing that a well-designed performance management system could enhance organization-wide participation in strategy shaping (Franco-Santos, Lucianetti, & Bourne, 2012), leading to improved strategy implementation (de Leeuw & van den Berg, 2011).

The strategy implementation dilemma is understandable as strategy is a complex concept, given its multidimensional, multileveled nature (Pettigrew, 1987) drawing on multiple disciplines, which is continuously shaped to adapt to the ever-changing environment. This paper focuses on the strategy dimension of 'how to compete', which entails a range of activities, including innovation, which in turn is influenced by a number of factors, specifically leadership (Teece, Peteraf, & Leih, 2016). Leadership is understood to refer to the process of influencing (directly and/or indirectly) others to achieve a desired outcome, such as a goal. The influence stems from the culture of the organization, which is understood as 'the way we do things'. Culture signals which behaviors are

acceptable, and consequently facilitates or curtails strategy implementation and attaining planned organizational performance. These behaviors include adapting to changing conditions and by doing so shaping competitive advantage (Teece et al., 2016).

Competitive advantage, i.e. something the organization does better than the competition in attracting customers on the basis of value offered (Barney, 1991; Porter, 1985), is the hallmark of a sound strategy, and consists of three interrelated dimensions (Nienaber, Cant, & Strydom, 2002). Of these dimensions, resources (assets, processes, systems, people and the like) are most important, while human resources are vital given their competence required to shape, and in particular, to implement strategy (Grant, 2016; Lockwood, 2007; Pfeffer, 2010). Evidently, while all resources are required to ensure organizational performance, not all are equally important to organizational performance (Barney, 1991; LePak & Snell, 2002; Teece, 2014). By combining resources, especially employees, leadership down the line optimally ensures performance (Barney, 1991; LePak & Snell, 2002; Teece, 2014), which includes creating an environment that fosters performance in a way that employees are 'available' to use their competence in pursuit of organizational goals (Cheese et al., 2008; Kahn, 1990; Saks, 2006; Schaufeli, Salanova, González-Romá, & Bakker, 2002; Teece, 2014). In this regard, employees' knowledge (explicit and tacit) is of particular interest, as such knowledge is difficult to imitate due to its intangible nature, and shapes competitive advantage (Teece et al., 2016). Although knowledge resides in the heads of individuals, it can be aggregated and deployed in the organization depending on the capacity of leadership down the line to allocate and coordinate resources (Barney, 1991; Mencl, Wefald, & van Ittersum, 2016; Teece et al., 2016), which is underpinned by the dynamic capabilities of the organization, stemming from tacit knowledge (Teece et al., 2016). In addition, it has been noted that employees require autonomy in applying their knowledge, which refers to the extent that an individual enjoys independence and freedom in carrying out assigned tasks (Hackman & Oldham, 1975) in pursuit of organizational goals. Autonomy demands time to think, experiment and learn, and it has been found (Reijseger, Peeters, Taris, & Schaufeli, 2017) that employees with high levels of autonomy are likely to participate in behaviors, such as engagement, enabling them to adapt (proactively) to changing conditions, which supports the sustainability of the organization. Scholars have noted that applying knowledge requires energy, and thus leadership down the line should harness employees' energy. Moreover, energy is also associated with producing engagement (Kahn, 1990, 1992; Schaufeli et al., 2002), which unlocks employee availability.

Given the importance of employees in organizational performance, increased attention is devoted to talent management – that is the recruitment, development and retention of employees with the required competence across occupations and hierarchies (Fegley, 2006; Gallardo-Gallardo & Thunnissen, 2016) to execute strategy. However, it is realized that talent management alone may not be sufficient to drive organizational performance. Authors agree that it is rather 'engaged' employees, who secure organizational performance, although authors are not unanimous about the concept of engagement (Christian, Garza, & Slaughter, 2011; Frank, Finnegan, & Taylor, 2004; Gruman & Saks, 2011; Harter, Schmidt, & Hayes, 2002; Kahn, 1990; Mone, Eisinger, Guggenheim, Price, & Stine, 2011; Nienaber & Martins, 2015; Schaufeli & Salanova, 2011; Saks, 2006; Shuck & Rose, 2015). In brief, 'engagement' refers to employees' choice to invest their authentic selves willingly and fully in their work roles (Kahn, 1990; Saks, 2006), which is influenced by organizational factors at both the team/unit and organizational level (Cheese et al., 2008; Kahn, 1990, 1992; Nienaber & Martins, 2015). Hence, employees 'do' engagement, which is influenced by the context in which they work.

It has been suggested that engagement can be fostered by performance management (Chartered Institute of Personnel and Development [CIPD], 2016; Gruman & Saks, 2011; Mone et al., 2011), which forms part of the context of engagement. Performance management transcends performance evaluation, which is at its core (Bourne, Pavlov, Franco-Santos, Lucianetti, & Mura, 2013; CIPD, 2010, 2016, 2017; DeNisi & Smith, 2014). Essentially, performance management aims at accomplishing desired goals, which are aligned with the strategic direction of the organization (CIPD, 2010; DeNisi & Smith, 2014). If carefully designed and applied, performance management has the potential to align employee attitudes and behavior with organizational priorities, which could lead to goal achievement (de Leeuw & van den Berg, 2011). Needless to say, the immediate manager plays an important role in performance management, in particular as a representative of the employer in administering performance evaluation, which forms part of human resource management practices (CIPD, 2016, 2017). In this role, immediate managers, among others, plan and monitor performance by giving effect to output, behavioral and organizational controls (CIPD, 2016). At the same time, immediate managers play an important role in engendering engagement (CIPD,

2017; Frank et al., 2004; Harter, 2015). Hence, behaviors of immediate managers are important (CIPD, 2014, 2016). Some authors call attention to the importance of interpersonal skills (emotional and political) of the immediate managers (Mencl et al., 2016), which foster inter alia trust, which is important in engagement (CIPD, 2017; Nienaber & Martins, 2015). It is particularly political skills that are important as immediate managers are bound by the structure of the employer (including but not limited to culture, policies, procedures, processes and systems which include performance evaluation) (Bourne et al., 2013; DeNisi & Smith, 2014; Skivington & Daft, 1991), which generally seems to be overlooked. Hence, some authors highlight the importance of communication, not only between the immediate manager and reportees, but also between immediate managers and top management (CIPD, 2017; Francis, Ramdhony, Reddington, & Staines, 2013) to modify structural aspects to improve performance. It is especially dialog that may alter work relationships (especially pertaining to structural aspects of the organization) resulting in (improved) employee engagement and organizational performance (Francis et al., 2013). Communication may thus foster a symbiotic relationship between the organization and its members. This is particularly relevant in the age of the knowledge worker where innovation is important in driving engagement, strategy and performance (Pettigrew, 1987; Reijseger et al., 2017; Teece et al., 2016).

This brief introduction demonstrates that strategy is important for the long-term sustainability of the organization, which is influenced by leadership down the line, particularly the immediate manager, performance evaluation and employee engagement, which are all interweaved, and thus pose challenges for organizational performance. The question was “what is the role of the immediate manager in employee engagement”. Hence, the aim of this paper was to examine the factor ‘immediate manager’, which scored the second lowest of all factors (comprising employee engagement) measured in a country-wide engagement survey (2015), and its effect on employee engagement. The research question was translated to the following hypothesis ‘the dimension immediate manager significantly predicts employee engagement’. The significance of the findings was that the immediate manager plays a vital role in ensuring organizational performance by engendering employee engagement. This paper contributes to theory by integrating literature from strategy, employee engagement and performance management, which has not been done before. The practical implication is that the immediate manager could enhance employee engagement by improving performance evaluation and feedback to employees, contributing to improved organizational performance. The sections that follow elaborate on the theoretical description of the concepts ‘employee engagement’, ‘the role of the line manager in employee engagement’, and ‘performance evaluation’, which all influence organizational performance. This is followed by the method used to study the contribution of the immediate manager to employee engagement, the results and discussion of the results and the paper closes with conclusions and recommendations for improving employee engagement.

LITERATURE

Employee Engagement

Different conceptualizations of engagement exist in the literature (Harter et al., 2002; Kahn 1990; Nienaber & Martins, 2015; Saks 2006; Schaufeli et al., 2002) which, according to Saks (2006) and Schaufeli and Salanova (2011), represent different types of engagement. Accordingly, different scales are available to measure engagement. Engagement at individual level, or work engagement, is the most commonly used type of engagement and most often corresponds to the conceptualizations by Schaufeli et al. (2002) and Kahn (1990) (Byrne, Peters, & Weston, 2016). However, given that organizational factors influence engagement, it has been suggested that engagement at organizational level, or employee engagement, may be a better way of studying the link between engagement and organizational performance (Harter et al., 2002; Nienaber & Martins, 2015; Saks, 2006) as it presents engagement as both condition and outcome (Shuck & Rose, 2015). The engagement conceptualization by Kahn (1990, 1992) is considered somewhat broader than that by Schaufeli et al. (2002) and represents engagement as both condition and outcome (Nienaber, 2017). For Kahn (1990:700), engagement refers to “employees’ choice to willingly and fully invest their authentic selves physically, cognitively and emotionally in their work roles that promote connections to work and to others, personal presence and active, full role performances”. The state of engagement enables people to express their thoughts and feelings, to question assumptions and to innovate, which is admittedly influenced by the individual and organizational factors (Kahn, 1992).

Employees' choice to invest themselves fully in their work roles is influenced by organizational factors such as leadership, trust, work design, strategy and competitive advantage (Cheese et al. 2008; Kahn, 1990, 1992; Nienaber & Martins, 2015) and can be summarized by the psychological conditions of meaningfulness, safety and availability proposed by Kahn (1990, 1992). 'Psychological meaningfulness' indicates how significant it is for the employee to bring his or her authentic self to the workplace in view of the 'return' he or she receives for doing so. This is influenced by task characteristics (e.g. clearly delineated, challenging, variety), role characteristics (e.g. identities that organization members are implicitly required to assume, which they may like or dislike), and work interactions (interpersonal interactions with co-workers and clients). 'Psychological safety' refers to how safe it is for the employee to bring his or her authentic self to the workplace without fear of negative consequences for his or her self-image, status or career. This is influenced by interpersonal relationships (especially characterized by support and trust), group dynamics (e.g. unacknowledged and/or unconscious roles affecting conscious working), management style and processes (e.g. openness and support) and organizational norms (shared expectations about the general behaviors of system members). 'Psychological availability' refers to how ready an employee is to bring his or her authentic self to the workplace because of the resources he or she has to engage personally at a particular moment. This is influenced by depletion of physical energy (e.g. long working hours, heavy workloads) and depletion of emotional energy (e.g. frustration in getting job done), insecurity (e.g. a lack of self-confidence) and outside lives (non-work lives) (Kahn, 1992).

The psychological conditions of meaningfulness, safety and availability proposed by Kahn (1990, 1992) can be achieved by activating the six drivers of engagement proposed by Cheese et al. (2008), namely:

- content of the work – includes the demands (physical and emotional) the job makes on the employee, the sense of achievement that the job offers, the opportunity to learn new things, and the question whether the job is meaningful and leads to some form of satisfaction;
- coping – indicates whether the employee has been equipped with the means to handle the job, including whether his or her goals are achievable. Coping comprises knowledge, skills, health, technology and training as well as a favorable working environment, supportive managers and colleagues and work practices and processes that reduce effort rather than adding to it;
- compensation – denotes the employee's belief of being fairly remunerated and being recognized for his or her contribution;
- community – refers to a feeling of positive social interactions in the workplace and whether the work is believed to be fulfilling, meaningful, enjoyable and fun, and whether it is done in a supportive or collaborative environment rather than a hostile environment;
- congruence – refers to the agreement between the individual and organizational values and alignment of expectations, and includes values that have been met; and
- career – denotes the alignment between the career, life expectations and aspirations of the individual, including work-life balance, whether the organization is investing in employees and whether employees can shape their own destiny.
-

In addition, the psychological conditions of meaningfulness, safety and availability proposed by Kahn (1990, 1992) can be accomplished by job design as offered by Hackman and Oldham (1975). This can activate (or restrain) the drivers of engagement as proposed by Cheese et al. (2008). Job design holds that positive personal and work outcomes can be obtained when three psychological states, namely experienced meaningfulness of the work, experienced responsibility for the outcome of the work, and knowledge of the outcome of the work are simultaneously present for a given employee. These psychological states are created by the presence of five core job dimensions, viz. skill variety, task identity and task significance, which enhance meaningfulness, high autonomy, which increases experienced responsibility for work, and high (quality) feedback, which improves knowledge of results of the job (Hackman & Oldham, 1975). Evidently, to be effective, job design should follow from and be aligned with the goals of the organization.

In sum, to activate engagement, leadership down the line should know their employees and specifically what they are capable of, trusting them to do their best, giving them the opportunity as well as empowering them to do so, and recognizing them for their contribution to achieve organizational goals. In addition, engagement requires good two-way communication and interaction between all stakeholders, specifically the immediate managers and

employees. It is surprising though that globally, few employees are engaged. In a study, Aon Hewitt (2017) found that 24% of the respondents were highly engaged, while 39% were moderately engaged. Moreover, it is maintained that organizational management, especially the immediate manager, affects a range of issues that directly influence engagement; hence, to benefit from the immediate manager, top management should not bypass immediate managers in shaping strategy (CIPD, 2014, 2017; Saks, 2006), as the immediate manager explains 70% of variation in employee engagement (Harter, 2015).

The Role of the Line Manager

Leaders down the line, and in particular their interpersonal skills (both emotional and political), have been acknowledged as important in facilitating goal achievement (Frank et al., 2004; Mencl et al., 2016; Saks, 2006). Interpersonal skills contribute to creating an environment in which employees can perform and thus achieve organizational goals. In this regard, immediate managers act as representatives of the organization in overseeing human resource management practices and thus play a significant role in the human resource management–performance chain (DeNisi & Smith, 2014; Mencl et al., 2016; Mone et al., 2011). In discharging their duties, immediate managers signal to employees the value placed upon them by the organization, both in terms of the way management implement human resource management practices and through their leadership style, by treating employees fairly and respectfully; providing autonomy to employees and empowering them to do their job; participating in quality two-way communication; clarifying expectations; encouraging employees to give and implement their views because their opinions count and make a difference; and behaving in a way that is congruent to the stated organizational values, which builds trust and provide a sense of integrity (CIPD, 2014, 2016, 2017; Frank et al., 2004).

It has been argued that it is not a single human resource practice, but rather complementary human resource practices (or bundles of human resource practices) that could lead to organizational performance (Bourne et al., 2012; DeNisi & Smith, 2014; Mone et al., 2011). However, it was pointed out that the link between these human resource practices and organizational performance might not be direct, but rather indirect as it may be mediated by a range of attitudinal and behavioral variables (Bourne et al., 2013; de Leeuw & van den Berg, 2011; DeNisi & Smith, 2014). In addition, it has been pointed out that the type of human resource practices implemented, e.g. transactional (which are focused on short-term exchange relationships) and/or commitment-based (emphasizing mutual, long-term exchanges) also influence organizational performance (Bourne et al., 2013). The latter has been shown to be more advantageous than the former for organizational performance and focused on three areas, namely (1) employee skills, including selective recruitment; (2) motivation, including such practices as performance-based rewards; and (3) empowerment, including participation mechanisms as they act synergistically (Bourne et al., 2013). It goes without saying that the immediate manager oversees these practices, which form part of performance management (which is a structural aspect of the organization), and which is provided for in performance evaluation.

Performance Evaluation

Performance evaluation is a process by which the performance of an individual employee is assessed for a specific period, resulting in a score, and it may or may not include developmental feedback (CIPD, 2017; DeNisi & Smith, 2014). Performance evaluation evolved from providing an accurate rating to focusing on performance improvement and later performance management, which leads to new models to manage and improve performance, which include aligning individual performance with organizational goals (Bourne et al., 2013; DeNisi & Smith, 2014). Performance evaluation is a continuous process of identifying, measuring and developing the performance of individuals and teams as well as aligning their performance with the strategic goals of the organization (DeNisi & Smith, 2014). Given that performance, from the perspective of the organization, is deemed to be a function of ability (or means and skills), motivation and opportunity (Blumberg & Pringle, 1982), it is obvious that the performance evaluation system of an organization should ensure that employees have the ability (or means and skills), the motivation and the opportunity to improve performance and, as such, to provide the basis for measuring these aspects (Bourne et al., 2013; DeNisi & Smith, 2014). Nevertheless, the performance evaluation system should result in practices that will enhance the ability or means and skills (like recruitment, selection and training); the motivation to do their work (for example performance contracting or setting goals, performance appraisal, compensation,

benefits, career development and job security); and the opportunity to contribute to performance (building a climate of trust and empowerment such as encouraging innovation and improving work processes, providing resources and decision-making authority to perform effectively as well as control over work, and treating employees respectfully and fair) (DeNisi & Smith, 2014; Gruman & Saks, 2011; Mone et al., 2011).

Moreover, to be effective, these practices should be perceived as fair. Open discussion should accompany goals to be achieved, and employees must feel empowered to perform and discuss feedback and development as part of their daily interactions (DeNisi & Smith, 2014). In this regard, it should be highlighted that performance evaluation might not necessarily contribute to performance improvement because of structural considerations. These include the organization is pursuing the wrong strategy (DeNisi & Smith, 2014); performance evaluation is not properly aligned and integrated with performance management; the system may influence behavior towards meeting measures rather than implementing organizational strategy and/or organizational performance should be ensured (Bourne et al., 2013; DeNisi & Smith, 2014), and the link between performance evaluation and business performance may not be clearly or convincingly established (Bourne et al., 2013; DeNisi & Smith, 2014).

Hence, it has been argued that performance evaluation should focus on a more proximal outcome, specifically employee engagement, rather than a distal outcome like organizational performance and goals (Gruman & Saks, 2011). In addition, scholars have argued that evidence for the link between performance management and human resource management (practices) is more compelling, as performance management interacts with human resource management (practices) (Bourne et al., 2013; CIPD, 2016; DeNisi & Smith, 2014).

METHOD

This paper reports on a part of a larger study (2015), which employed a survey as research design, collecting self-report data by using an electronic survey, administered by a permission-based database (comprising 285,000 economically active persons, occupying various roles in organizations, from all sectors of the standard industrial classification and of different sizes, reflecting the profile of economically active South Africans who willingly gave permission to participate in online surveys). Hence, convenience sampling was used, which may be criticized for its potential to be biased. However, because the respondents mirrored the typical population under study (Nienaber & Martins, 2015), the sample was considered to be appropriate for purposes of this study (Bono & McNamara, 2010). Self-reports may be susceptible to common method variance; however, it was considered the most appropriate method to use as subjective perceptions and experiences of individuals were required (Conway & Lance, 2011). Moreover, the anonymous responses countered common-method variance.

The Instrument Collecting Data

The study in question measured employee engagement in South Africa, a multicultural, emerging economy, using the validated engagement scale of Nienaber and Martins (2015) (with permission) for this context. Nienaber and Martins (2015) report that they developed the scale by following the typical steps for instrument development proposed by Hinkin (1998), which is similar to that of DeVellis (2013), while they heeded the guidelines of Aguinis and Edwards (2014) in connection with measurement as well as the recommendations of inter alia Johns (2006) in connection with context. Additionally, Nienaber and Martins (2015) point out that they followed the framework of Macey and Schneider (2008), which according to Christian et al. (2011), indicates discriminant validity. As such, the engagement measurement instrument used by Nienaber and Martins (2015) builds on and extends current engagement research, including scales, which have been part of prior research (Nienaber & Martins, 2015).

The Nienaber and Martins (2015) employee engagement scale consists of six factors, representing engagement at individual, team and organizational level. The individual level comprises trait, state and behavioral engagement, which are influenced by factors at team/unit level such as work design, leadership and trust. These aspects in turn are influenced by factors at organizational level such as vision, mission, goals and strategy, which are anchored in the competitive advantage of the organization (Nienaber & Martins, 2015). The instrument may be considered solid because each of the six factors consists of at least five or more items (Hinkin, 1998), while the validity, discriminant validity, convergent validity and reliability of the instrument have been established (Martins,

2016; Nienaber & Martins, 2015). The Cronbach's alpha for the six dimensions ranged between 0.813 and 0.942, while the indices of the base model were all at levels recommended by the relevant researchers in the field (Nienaber & Martins, 2015:415-416).

The instrument consisted of 69 questions, nine of which collected biographical information (gender, qualifications, experience and tenure) and 60 required responses to statements about engagement at individual, team/unit and organizational level, using a five-point Likert-type scale, widely used to measure opinion, belief and attitude (DeVellis, 2013), such as engagement. Examples of statements include "I feel positive about my work" (individual level); "My team continuously strives to improve performance in line with our business objectives" (team/unit level); and "We have a competitive advantage in the market" (organizational level) (Nienaber & Martins, 2015).

Data Analyses

Statistical analyses were conducted using SPSS23. The purpose of the present study was to examine the dimension 'immediate manager' because the immediate manager influences employee engagement significantly and thus affects organizational performance. Firstly, the factor scores for all dimensions of employee engagement were calculated by taking the average of the items that loaded onto the factor in question for each participant. This paper only reports on the dimension 'immediate manager' in detail. Secondly, the contribution of the dimension 'immediate manager' to the variation of employee engagement was studied by performing linear regression analysis (Terre Blanche, Durrheim, & Painter, 2007), where 'immediate manager' was treated as the independent variable and 'employee engagement' as the dependent variable. The assumptions of regression, namely normality, linearity, equality, co-linearity and outliers (Terre Blanche et al., 2007) were tested and satisfied.

RESULTS

Table 1 reflects the overall employee engagement factors (2015).

Table 1: Overall employee engagement factors (2015)

Engagement level	Dimensions	Count	Mean	Standard deviation
Team/unit	Team	4 099	4.05	0.832
Individual	Organizational satisfaction	4099	3.80	1.008
Individual	Organizational commitment	4099	3.73	1.145
Organizational	Customer service	4099	3.72	1.027
Team/unit	Immediate manager	4099	3.54	1.167
Organizational	Strategy and implementation	4 099	3.40	1.166
	Overall (all factors)	4099	3.73	1.0383

Source: Calculated from survey results

The results (means and standard deviations) show that the factor 'immediate manager' scored the second lowest of all factors and lower than the overall average for employee engagement. The factor 'strategy and implementation' scored the lowest of all factors, and also lower than the overall average for employee engagement. The factor 'team' scored the highest of all factors making up employee engagement.

Table 2 below shows the details for the dimension immediate manager (2015).

Table 2: Immediate manager as dimension of employee engagement (2015)

	Count	Mean	Standard

			deviation
Immediate manager	4 099	3.54	1.167
My immediate manager trusts me	4 099	3.95	0.931
I have the support from my immediate manager to do my job effectively	4 099	3.83	1.065
I trust my immediate manager	4099	3.59	1.237
My immediate manager inspires people in my business unit	4 099	3.44	1.223
My immediate manager does a good job of ‘managing the work’ – that is making appropriate work assignments, scheduling the work, setting priorities for me and my team	4 099	3.39	1.222
My immediate manager gives me regular feedback that helps me to improve my performance	4 099	3.33	1.235
I am satisfied with the way that my work performance is evaluated	4 099	3.24	1.255

Source: Calculated from survey results

The item “My immediate manager trusts me” was scored the most favorable of the items making up the factor ‘immediate manager’ followed by “I have the support from my immediate manager to do my job effectively”. “I am satisfied with the way my work performance is evaluated” ranked the lowest of all items comprising the factor ‘immediate manager’, while “My immediate manager gives me regular feedback that helps me to improve my performance” scored the second lowest of all items. The item “My immediate manager does a good job of ‘managing the work’ – that is making appropriate work assignments, scheduling the work, setting priorities for me and my team” scored the third lowest of all items making up ‘immediate manager’. These three items also scored lower than the mean for ‘immediate manager’, which was lower than the mean for employee engagement.

The result of the regression analysis is presented in Table 3.

Table 3 Model summary^b

Model	R	R square	Adjusted R square	Std. error of the estimate	Durbin–Watson
1	.722 ^a	0.521	0.521	0.49091	1.902

a Predictors: (constant), immediate manager

b Dependent variable: Average without immediate manager

According to the regression analysis, the factor ‘immediate manager’ contributes significantly to employee engagement as it explains (or predicts) 52.1% of variance in employee engagement (R square adjusted 0.521; F sig .000).

DISCUSSION

The factor ‘immediate manager’ scored the second lowest (3.54) of the factors making up ‘employee engagement’, which was lower than the overall engagement score (3.73). ‘Team’, on the other hand, scored the highest (4.05) of the factors making up employee engagement and above the overall employee engagement score. The items making up ‘immediate manager’ (Table 2) coincided with the literature, which is to a greater or lesser degree subject to interpersonal relationships. Leadership style builds trust and affects psychological availability (CIPD, 2014, 2016, 2017; Frank et al., 2004). The drivers of engagement (Cheese et al., 2008) are also reflected in these items, as well as aspects of job design (Hackman & Oldham, 1975), specifically feedback that could activate the drivers of engagement, which could achieve the psychological conditions of meaningfulness, safety and availability. Performance evaluation stems from performance management, which is a structural aspect of the organization (Blumberg & Pringle, 1982; Bourne et al., 2013; DeNisi & Smith, 2014; Franco-Santos et al., 2012; Mone et al., 2011; Skivington & Daft, 1991) and could be influenced by the immediate manager via interpersonal skills, specifically political skills (Mencl et al., 2016), and in particular dynamic capabilities (Mencl et al., 2016; Teece et

al., 2016), which are required to combine and allocate resources, particularly knowledge (Barney, 1991; LePak & Snell, 2002; Teece et al., 2016). The results indicate that the political skills of immediate managers may be underdeveloped. This might have an adverse effect on motivation (Bourne et al., 2013; DeNisi & Smith, 2014; Gruman & Saks, 2011) and the psychological safety and availability of employees (Cheese et al., 2008; de Leeuw & van den Berg, 2011; Kahn, 1990; Saks, 2006; Schaufeli et al., 2002; Teece, 2014), adversely affecting competitive advantage (Barney, 1991; Grant, 2016; Lockwood, 2007; Nienaber et al., 2002; Pfeffer, 2010; Porter, 1985; Teece et al., 2016) with dire consequences for organizational performance (Barney, 1991; Christian et al., 2011; Kahn, 1990, 1992; LePak & Snell, 2002; Porter, 1985; Teece, 2014; Teece et al., 2016).

According to the regression analysis, the factor ‘immediate manager’ contributes significantly to employee engagement as it predicts 52.1% (adjusted r^2) of variation in employee engagement as proportions of variance above 25 per cent are considered substantial (Heiman, 2014). This is consistent with the literature and congruent with the findings by Saks (2006) and Harter (2015) that the immediate manager contributes significantly to the variation in employee engagement. If organizations seek to improve employee engagement they should attend to the immediate manager, who plays a critical role in influencing an individual employee’s choice to engage or disengage (Kahn, 1990, 1992; Saks, 2006), and in particular to performance evaluation and feedback, which could be improved by political skills.

CONCLUSIONS AND RECOMMENDATIONS

Strategy implementation is important in the sustainability of organizations. According to the literature, leadership down the line plays an important role in strategy implementation. Literature also shows that if strategy implementation fails, it jeopardizing the sustainability of the organization. Strategy is complex, as it requires a range of activities, which in turn are influenced by a number of factors, notably leadership. The immediate manager plays a significant role in performance via employee engagement, which can be fostered by particularly performance evaluation and feedback.

The study reported on here demonstrated that the immediate manager is significant in employee engagement, both theoretically and empirically, as it explains 52.1% of variation in employee engagement (i.e. factual conclusion). It is therefore troubling to note that this factor scored the second lowest (3.54) of all factors making up ‘employee engagement’. In addition, the analyses also identified items that influence ‘immediate manager’, which is consistent with the literature (i.e. conceptual conclusion). Of these items, “I am satisfied with the way that my work performance is evaluated” scored the lowest, followed by “My immediate manager gives me regular feedback that helps me to improve my performance”, which scored the second lowest. “My immediate manager does a good job of ‘managing the work’ – that is making appropriate work assignments, scheduling the work, setting priorities for me and my team” scored the third lowest, which is concerning as performance evaluation, feedback and managing the work assist in enhancing employee engagement and aligning attitudes and behaviors of employees to goal achievement and thus organizational performance. These items are influenced by structural aspects of the organization as well as interpersonal relationships. The immediate manager could affect structural aspects, such as performance evaluation, both directly and indirectly, via political skills (combining and allocating resources) and communication and dialog (to adjust/adapt performance evaluation and performance management systems to reflect ‘knowledge work’). This aspect of performance evaluation forms part of giving feedback. Feedback falls in the direct sphere of influence of the immediate manager, which can be addressed by interpersonal skills, including political skills. The latter here needs some development. Nevertheless, this may be a daunting task, given the complexity of the concepts in question and their integrated nature. These also represent the contribution of the study i.e. the line manager plays a significant role in employee engagement, via performance evaluation. However, performance evaluation forms part of structural aspects of the organization, which are determined by top management. The implications (managerial and practical) of this study include that management must deliberately link strategy to performance management and evaluation. This can be done, inter alia, by policies, processes and practices (including commitment based human resource practices), which form part of structural aspects of the organization. To succeed in linking strategy and performance management, inputs of all role players, regardless of their position in the hierarchy of the organization, should be solicited of which the immediate manager are of particular relevance. Further research is therefore recommended.

REFERENCES

- Aguinis, H., & Edwards, J. R. (2014). Methodological wishes for the next decade and how to make wishes come true. *Journal of Management Studies*, 51, 143–174.
- Aon Hewitt. (2017). *Trends in global employee engagement: Global anxiety erodes employee engagement gains*. Retrieved from http://www.aon.com/engagement17/?utm_source=email&utm_medium=sotw&utm_campaign=empengage2017 (accessed 13 March 2017).
- Barney, J. (1991). Firm resources and sustained competitive advantage. *Journal of Management*, 17(1), 99–120.
- Blumberg, M., & Pringle, C. D. (1982). The missing opportunity in organizational research: Some implications for a theory of work performance. *Academy of Management Review*, 7, 560–569.
- Bono, J. E., & McNamara, G. (2010). From the editors publishing in *AMJ* – Part 2: Research design. *Academy of Management Journal*, 54(4), 657–660.
- Bourne, M., Pavlov, A., Franco-Santos, M., Lucianetti, L., & Mura, M. (2013). Generating organizational performance: The contributing effects of performance measurement and human resource management practices. *International Journal of Operations & Production Management*, 33(11/12), 1599–1622.
- Byrne, Z. S., Peters, J. M., & Weston, J. W. (2016). The struggle with employee engagement: Measures and construct clarification using five samples. *Journal of Applied Psychology*, 101(9), 1201–1227.
- Chartered Institute of Personnel and Development. (2010). *Performance management in action: Current trends and practices*. Retrieved from <http://www.CharteredInstituteofPersonnelandDevelopment.co.uk>. (Accessed on 7 July 2010).
- Chartered Institute of Personnel and Development. (2014). *Employee outlook: Focus on managers*. London.
- Chartered Institute of Personnel and Development. (2016). *The role of line managers in HR and L&D*. London.
- Chartered Institute of Personnel and Development. (2017). *Performance appraisal*. London.
- Cheese, P., Thomas, R. J., & Craig, E. (2008). *The talent powered organization: Strategies for globalisation, talent management and high performance*. London: Kogan Press.
- Christian, M. S., Garza, A. S., & Slaughter, J. E. (2011). Work engagement: A quantitative review and test of its relations with task and contextual performance. *Personnel Psychology*, 64, 89–136.
- Cocks, G. (2010). Emerging concepts for implementing strategy. *The TQM Journal*, 22(3), 260–266.
- Conway, J. M., & Lance, C. E. (2011). What reviewers should expect from authors regarding common method bias in organizational research. *Journal of Business and Psychology*, 25, 325–334.
- de Leeuw, S., & van den Berg, J. P. (2011). Improving operational performance by influencing shopfloor behaviour via performance management practices. *Journal of Operations Management*, 29, 224–235.
- DeNisi, A., & Smith, C. E. (2014). Performance appraisal, performance management, and firm-level performance: A review, a proposed model, and new directions for future research. *Academy of Management Annals*, 8(1), 127–179.
- DeVellis, R. F. (2013). *Scale development: Theory and practice* (3rd ed.). Thousand Oaks, CA: Sage.
- Fegley, S. (2006). *Talent management survey report*. Society for Human Resource Management. Retrieved from www.shrm.org/research. (Accessed on 13 April 2007)
- Francis, H. M., Ramdhony, A., Reddington, M., & Staines, H. (2013). Opening spaces for conversational practice: A conduit for effective engagement strategies and productive working arrangements. *The International Journal of Human Resource Management*, 24(14), 2713–2740.

- Franco-Santos, M., Lucianetti, L., & Bourne, M. (2012). Contemporary performance measurement systems: A review of their consequences and a framework for research. *Management Accounting Research*, 23, 79-119. <http://dx.doi.org/10.1016/j.mar.2012.04.001>.
- Frank, F. D., Finnegan, R. P., & Taylor, C. R. (2004). The race for talent: Retaining and engaging workers in the 21st century. *Human Resource Planning*, 27(3), 12–25.
- Gallardo-Gallardo, E., & Thunnissen, M. (2016). Standing on the shoulders of giants? A critical review of empirical talent management research. *Employee Relations*, 38(1), 31–56. doi:10.1108/ER-10-2015-0194 (Accessed 30 December 2015).
- Grant, R. M. (2016). *Contemporary strategy analysis* (9th ed.). West Sussex: Wiley.
- Gruman, J. A., & Saks, A. M. (2011). Performance management and employee engagement. *Human Resource Management Review*, 21, 123–136.
- Hackman, J. R., & Oldham, G. R. (1975). Development of the job diagnostic survey. *Journal of Applied Psychology*, 60(2), 159–170.
- Harter, J. (2015). Who drives employee engagement — manager or CEO? Available at http://www.gallup.com/topic/employee_engagement.aspx. (Accessed 26 April 2016).
- Harter, J. K., Schmidt, F. L., & Hayes, T. L. (2002). Business-level-unit relationship between employee satisfaction, employee engagement, and business outcomes: A meta-analysis. *Journal of Applied Psychology*, 87(2), 268–279.
- Heiman, G. W. (2014). *Understanding Research Methods and Statistics: An Integrated Introduction for Psychology*, 7th ed. Wadsworth: Cengage Learning
- Hinkin, T. R. (1998). A brief tutorial on the development of measures for use in survey questionnaires. *Organizational Research Methods*, 1, 104–121.
- Jarzabkowski, P., & Spee, A. P. (2009). Strategy-as-practice: A review and future directions for the field. *International Journal of Management Reviews*, 11(1), 69–95.
- Johns, G. (2006). The essential impact of context on organizational behaviour. *Academy of Management Review*, 31(2), 386–408.
- Kahn, W. A. (1990). Psychological conditions of personal engagement and disengagement at work. *Academy of Management Journal*, 33(4), 692–724.
- Kahn, W. A. (1992). To be fully there: Psychological presence at work. *Human Relations*, 45(4), 321–349.
- LePak, D. P., & Snell, S. A. (2002). Examining the human resource architecture: The relationships among human capital, employment, and human resource configurations. *Journal of Management*, 28(4), 517–543.
- Lockwood, N. (2007). Leveraging employee engagement for competitive advantage: HR's strategic role. *Society for Human Resource Management Research Quarterly*, 3(1), 1–11.
- Macey, W. H., & Schneider, B. (2008). The meaning of engagement. *Industrial and Organizational Psychology*, 1, 3–30.
- Mankins, M. C., & Steele, R. (2005). Turning great strategy into great performance. *Harvard Business Review*, July–August, 65–72.
- Maritns, N. (2016, 9–10 June). *Confirming the measurement properties of an engagement measure*. Paper presented at the 15th European Conference on Research Methodology for Business and Management studies, Kingston Business School, Kingston University, London.
- Mencl, J., Wefald, A. J., & van Ittersum, K. W. (2016). Transformational leader attributes: Interpersonal skills, engagement, and well-being. *Leadership & Organization Development Journal*, 37(5), 635–657.
- Micheli, P., & Mura, M. (2017). Executing strategy through comprehensive performance measurement systems. *International Journal of Operations & Production Management*, 37(4), 423–443.

- Mone, E., Eisinger, C., Guggenheim, K., Price, B., & Stine, C. (2011). Performance management at the wheel: Driving employee engagement in organizations. *Journal of Business Psychology*, 26, 205–212.
- Nienaber, H. (2017, 16–17 March). *Leadership, risk taking and employee engagement in a South African context*. Paper presented at the 5th International Conference on Management Leadership and Governance ICMLG 2017, Wits Business School, University of Witwatersrand, Johannesburg.
- Nienaber, H., Cant, M. C., & Strydom, J. W. (2002). An exploratory investigation into the application of market strategies by selected JSE-listed companies in the food sector in the period 1996–1999. *Southern African Business Review*, 6(1), 24–30.
- Nienaber, H., & Martins, N. (2015). Validating a scale measuring engagement in a South African context. *Journal of Contemporary Management*, 12, 401–425.
- Pettigrew, A.M. (1987). Context and action in the transformation of the firm. *Journal of Management Studies*, 24(6), 649–670.
- Pfeffer, J. (2010). Building sustainable organizations: The human factor. *Academy of Management Perspective*, February, 34–45.
- Porter, M. (1985). *Competitive advantage: Creating and sustaining superior performance*. New York, NY: The Free Press.
- Reijseger, G. M., Peeters, C. W., Taris, T. W., & Schaufeli, W. B. (2017). From motivation to activation: Why engaged workers are better performers. *Journal of Business and Psychology*, 32(2), 117–130.
- Saks, A. M. (2006). Antecedents and consequences of employee engagement. *Journal of Managerial Psychology*, 21(7), 600–619.
- Schaufeli, W. B., & Salanova, M. (2011). Work engagement: On how to better catch a slippery concept. *European Journal of Work and Organization Psychology*, 20(1), 39–46.
- Schaufeli, W. B., Salanova, M., González-Romá, V., & Bakker, A. B. (2002). The measurement of engagement and burnout: A confirmative analytic approach. *Journal of Happiness Studies*, 3, 71–92.
- Shuck, B., & Rose, K. (2015). Reframing employee engagement within the context of meaning and purpose: Implications for HRD. *Advances in Developing Human Resources*, 15(4), 341–355.
- Skivington, J. E., & Daft, R. L. (1991). A study of organizational ‘framework’ and ‘process’ modalities for the implementation of business-level strategic decision. *Journal of Management Studies*, 28(1), 45–68.
- Teece, D., Peteraf, M., & Leih, S. (2016). Dynamic capabilities and organizational agility: Risk, uncertainty and strategy in the innovation economy. *California Management Review*, 58(4), 13–35.
- Teece, D. J. (2014). The foundations of enterprise performance: Dynamic and ordinary capabilities in an (economic) theory of firms. *The Academy of Management Perspectives*, 28(4), 328–352.
- Terre Blanche, M., Durrheim, K., & Painter, D. (Eds.). (2007). *Research in practice: Applied methods in the social sciences*. Cape Town: University of Cape Town Press.
- Van der Merwe, M. M., & Nienaber, H. (2015). Factors hindering strategy implementation as perceived by top, middle and frontline managers in a South African electronics organization. *Journal of Global Business and Technology*, 11(2), 45–57.

TRADITIONAL FOODS ARE SAFE FOR CONSUMPTION: A CASE STUDY IN NOMPUMELELO COMMUNITY, EAST LONDON, EASTERN CAPE PROVINCE

Vikelwa Nomnga
Walter Sisulu University, South Africa

ABSTRACT

Traditional foods have therefore been identified as one of the strategies that can be employed to lessen the problem of food security in the community of Nompumelelo, Duccats, EC Province and the research involves the availability of traditional foods in the area. It is a common practice for most rural people in South Africa to include traditional foods in their diets and Duccats, Nompumelelo is no exception. Hence the study explores these rural – urban households. The traditional foods that are produced in these communities are accessible to the whole community. The outcome is in greater food sustainability. Traditional foods are locally available and they are growing as natural vegetation. The sustenance of many rural societies over many generations has resulted from their reliance on a broad food base, including traditional foods, to supply their nutritional requirements. In many traditional African cultures, the main meal comprises of a starch staple such as imifuno, which is accompanied by a supplement, the relish of traditional plants and vegetables, meat, or a combination of both, which provides the other nutritional elements, as well as flavor. The relish is, therefore, an important component of the diet. Rural households normally make use of traditional foods, such as relish, for household consumption and trade to generate income. In contrast, poor rural communities adopt a range of livelihood strategies, including the consumption of, and trade in, natural resources, which might be used for traditional food, doing so in order to improve their lifestyle. Local urban farmers, in seeking a better living than might otherwise be possible, select the best of their products, such as grapes, peaches, bananas, and apples as well as wine, for the overseas, as opposed to the local, market, as well as for their own daily consumption. Although poor people tend to sell their traditional foods instead of using them in their own households, reliance on traditional foods, including plants, was noted that food security in Nompumelelo, Duccats area, was partly attributable to the fact that traditional plants or vegetable foods were the primary component of the local communities' diet.

Keywords: Traditional foods, rural – urban areas, community, households, consumption and Food security.

INTRODUCTION

Malnutrition is a worldwide problem and the most important risk factor for illness and death (WHO, 2000). A high rate of micronutrient deficiencies in East London with the most vulnerable groups being children and women. Several strategies that can be employed to alleviate micronutrient deficiency include supplementation, fortification, public health programs and biofortification. Biofortification is found to be the most sustainable way of reducing and controlling micronutrient deficiencies in resources-poor communities.

Traditional foods are being displaced in many areas, partly because they are being neglected by the science community, in comparison to some recently introduced western foods, which are more easily available (Shava, 2000). As such, the consumption of the rural-urban linkage in the use of traditional foods by peri-urban households in the Nompumelelo community in the Eastern Cape South Africa: a comparative study traditional foods is decreasing, even in the rural areas of South Africa, in favour of introduced foods. The neglect by both policy-makers and researchers has led to a scarcity of information about traditional foods (Jansen van Rensburg, et al., 2004).

Documentation on traditional foods is scarce, with only elderly people remaining as the most valuable sources of information (Shava, 2000). The fear exists that, if nothing is done to preserve valuable information on traditional foods, this information may soon disappear from society, because the youth are generally reluctant to learn about such foods (Voster&Rensburg, 2007). As such, a research study of traditional foods was envisaged. The results of the study could improve the current lack of research on and knowledge about traditional foods. Although the community of Nompumelelo is largely poor, it has the potential to farm traditional foods and even to supply adjacent urban areas.

LITERATURE REVIEW

A historical perspective of traditional foods in the Eastern Cape

The history of South Africa shows that most traditional rural people in South Africa moved to the south of KwaZulu-Natal about 1,500 years ago (Thompson, 2000). These people were primarily nomadic farmers, who combined knowledge of cattle-keeping and slash-and-burn cultivation with expertise in metalwork. The farmers chose to minimise the risk of crop failure rather than to maximise their production (Thompson, 2000). These rural people kept large herds of cattle and attached great material and symbolic value to these animals (Nesamvuni, 2000). Cattle were valued for their milk and hides, but were seldom slaughtered for meat, except for ceremonial occasions. Hunting game provided them with meat, a major source of protein, while additional supplies came from domesticated goats and sheep. Furthermore, rural people cultivated a range of traditional crops, including millet, sorghum, beans and melons, along with other grains and vegetables (Nesamvuni, 2000). Those people who settled close to the sea fished and collected shellfish. By using a range of food sources, the farmers spread the risks of food insecurity in an ecological system that was constantly subject to drought, disease and crop failure (Nesamvuni, 2000).

Traditional foods used by people in the rural areas of South Africa were derived mainly from wild edible plants (Fox & Young, 1982). The introduction of new crops and foods by Europeans, and new techniques for growing the crops resulted in a change of diet (Fox & Young, 1982; Thompson, 2000). The introduction of white-owned trading stores with attractive food items, such as processed fats and spices, meant that people had to find employment in order to afford to buy from the trading stores (Callinicos, 2004; Fox & Young, 1982). The growing population and an increase in livestock resulted in people having to pay the taxes and levies imposed by their chiefs (Callinicos, 2004). With time, it became impossible for the rural people to provide enough food for their households without having also to earn cash (Fox & Young, 1982; Thompson, 2000). The result of these changes was that people increasingly came to rely on purchased foods (Thompson, 2000). The reliance on processed foods very likely led to traditional foods becoming less dominant in traditional people's diets. There may be many other factors, however, that influenced the decline of traditional diets in the rural culture, such as improved knowledge about other food types and changing socioeconomic circumstances. In spite of western influence, there is evidence that traditional people in rural areas have maintained elements of their traditional lifestyles, including their tendency to use traditional foods (Fox & Young, 1982). Unfortunately, published literature on how traditional diets have been modified through the influences of modernisation (the introduction of exotic foods and associated changes in lifestyles affecting preferences) is very scarce.

Historical and contemporary Xhosa traditional foods

As a matter of fact, it is true that almost all rural people make traditional foods from cultivated crops and edible wild plants collected from cultivated fields and/or the veld (Modi, 2009). Cultivated traditional crops typically include cereals, legumes and cucurbits (Modi, 2009). Historically, the most common legumes used by rural people were cowpeas and groundnuts (Fox & Young, 1982). Popular cereals were bulrush millet, finger millet and sorghum (Fox & Young, 1982). Popular cucurbits were gourds; African melons see figure 2.1 below, and pumpkins (Fox & Young, 1982). These crops were used to make a variety of traditional dishes. An example of a popular traditional dish in rural areas is shown in figure 2.2, and commonly used traditional vegetables for preparing traditional foods are shown in figure 2.3.

Figure 1.1: African melon, a traditional cucurbit of the Eastern Cape, known as umxoxozi in isiXhosa (Source: Modi, 2009)



Figure 1.2: Four plates of umqa, a traditional Xhosa dish (Source: Modi, 2009).



Even though table 1.2 shows popular traditional foods, the taste of these foods is changing due to modern ingredients currently being added, such as spices and cooking oil, which were not previously part of rural people's diet (Modi, 2009). Disuse of some traditional ingredients, such as traditional and wild plants, may be due to their lack of availability, lack of knowledge (for instance, their nutritional value, cooking guidelines and so forth) about them, and pressure to comply with modern preferences in food tastes (Drewnowski, Henderson, Levine & Hann, 1992). Despite the rich food culture of rural people (Nyembezi&Nxumalo, 1966; Sosibo& Harvey, 2000) and interest in it, there has been no attempt to quantify the nutritional value of traditional dishes. Little literature has been published on the nutritional value of traditional dishes in South Africa, apart from the information on specific ingredients that was made available by Kruger, Sayed and Kirsten (1998). Recent studies, such as that of Modi and Modi (2006) and Mbenyane, Venter and Laker (2005) have argued that there may be a decline in knowledge about traditional foods. Modi and Modi (2006) suggested that wild vegetables are comparable, or might even be better than conventional vegetables, with regard to some nutrients. Mbenyane, et al. (2005), postulated that there is a need for investigation into the nutrient status of traditional foods, in order to promote their consumption in South Africa.

Significance of traditional foods in the history of the Xhosa people

A few studies on the uses of traditional foods have been conducted in different regions of South Africa. Wehmeyer and Rose (1983) examined the traditional foods used in the Transkei, Eastern Cape Province, whereas Ferreira (1996) studied traditional plants used for medicinal purposes in the Western Cape. Nompumelelo is one of the communities where edible traditional foods are still frequently used. The gathering and use of traditional foods have been noted as activities that still take place in the rural parts of the Eastern Cape Province. Historically, rural people extensively used various types of traditional foods and had a wealth of knowledge about plants (Mabongo, 1990). Apart from eating the plants, they also used them to produce oils, medicine, firewood, beverages, baskets and other artefacts.

MATERIALS AND METHODS

Description of study area

The study was conducted in Nompumelelo which is situated within the Eastern Cape province of South Africa, about 10 km north-east of East London. According to Buffalo City Municipality (BCM)(2004) the area is a peri-urban community, with a population of around 1,200 families. According to the South African Cities Network (2004) the area is in transition, with houses increasingly becoming electrified, and steadily more water and sanitation services being supplied. Historically, the area houses migrants from the rural areas of two former homelands, namely the Transkei and Ciskei, who moved into the area in an effort to seek employment. Nompumelelo, which is adjacent to the upmarket suburb of Beacon Bay, used to be a squatter camp with an impoverished community, before the government built rural development programme houses in the area.

The Nompumelelo surroundings are portrayed in the following figures. Figure 1.1 below shows that the Nompumelelo community still needs more development, as can be seen from the fact that the local streets are not tarred. Despite Nompumelelo lying within the East London city boundaries, in the Beacon Bay area where advantaged people reside, most of the houses in the area are mere shacks. In addition, government intervention is urgently required, as the community is severely disadvantaged. Below is a pictorial view of Nompumelelo.



Source (Nomnga, 2009)

Data collection method and analysis

The article used interviews, focus groups and questionnaires to collect data. The rationale behind using interviews was that, the researcher sought to share her concerns (which were related to health, traditional food and nutrition) with those female residents of Nompumelelo who were single parents. Such a focus would allow light to be shed on learning by means of co-engaged interactions about local practices and emerging concerns. A set of between 30 and 40 households were systematically selected, with focus group questionnaires relating to the use of traditional foods by the Xhosa community of Nompumelelo being administered to female single parents who were responsible for the food preparations in their households, as it was assumed that they were suitable candidates to interview about food accessibility and its utilisation. The data obtained by means of the current study were verified and compared with other research on traditional foods that was conducted in the rest of Africa and in other parts of the world. The literature study, as described in chapter 2 of the current thesis, focused on material relating to the accessibility of food. A set of 40 Xhosa households from the peri-urban community of Nompumelelo was selected and interviewed. The interviewees were asked about their awareness of the rural-urban linkage in the use of traditional foods by peri-urban households in Nompumelelo, and also about how they utilised food in their households.

RESULTS AND DISCUSSION

The article seeks to explore perceptions of Nompumelelo community members regarding the use of traditional leafy vegetables (TLVs) to increase food security for poverty alleviation. Descriptive statistics has been used to present quantitative data, themes were used to present qualitative data.

Consumption of traditional foods in Nompumelelo

The results revealed that, varieties of traditional food consumed are found within Nompumelelo community of which many are processed and stored. The article established the scarcity and coping strategies respectively by households in times of shortages of foods. Also, the results revealed that the consumption of traditional foods by the younger generation, meaning generation Y, is decreasing. The respondents indicated that they only consumed those

traditional foods that were known to be nutritious, such as *umnqutsho*, *ithanga*, *ikhiwane* and *umbona*. The consumption of traditional foods was largely attributed to the introduction of new foods and to the change in food preferences, which literally translates to a change in food habits.

The paper observes a change in lifestyle as another factor that was reported to be responsible for the decrease in the consumption of traditional foods by members of the community. In modern-day communities, people are no longer keen on walking long distances to gather traditional foods, so that they have lost interest in foraging in the forests and in ploughing the fields. Results revealed further that, education and urbanisation have also led to the negative reception of traditional foods, largely as a result of instilling new values and attitudes among the youth, at the expense of past cultural norms (Shava, 1999). Reduced consumption of traditional foods is a major concern, as it is the first sign of their pending extinction (Keller & Lapata, 2005).

Chart showing percentage of those in different age groups in the Nompumelelo community

Nompumelelo community

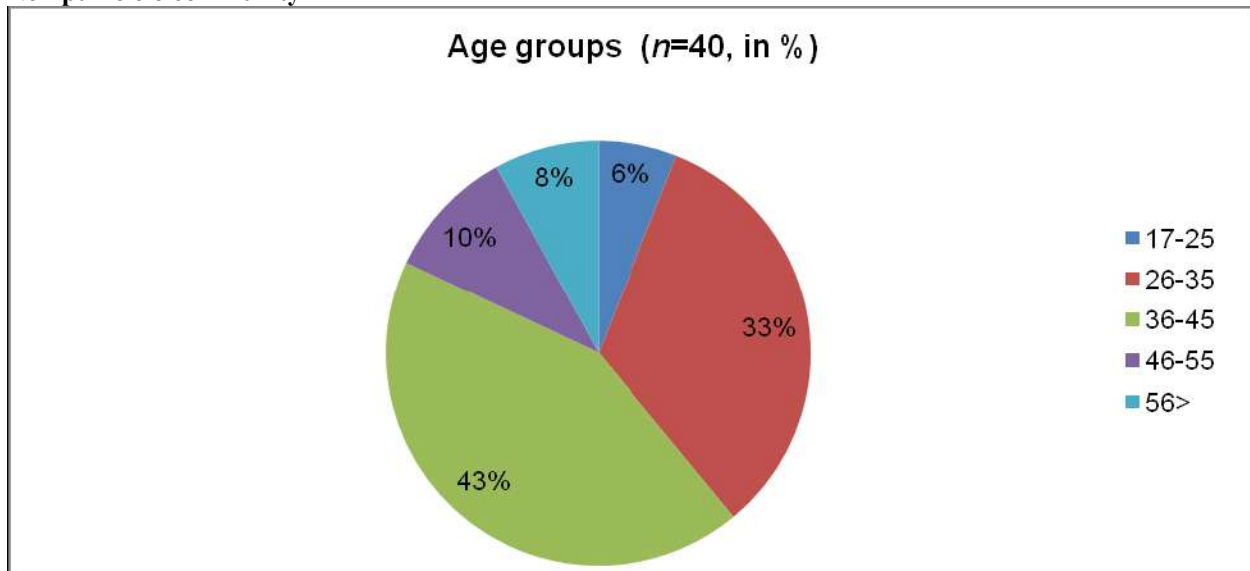

From the chart it can be shown that, ages 36-45 which is the economically active group has higher consumption of traditional foods. The reason maybe most of them are not working due to low education levels and lack of skills.

Food bought monthly

The consumption of traditional and modern foods by residents in Nompumelelo varies according to their affordability. The figure 1.2 below shows the food bought monthly by Nompumelelo residents, together with the percentages of each food.

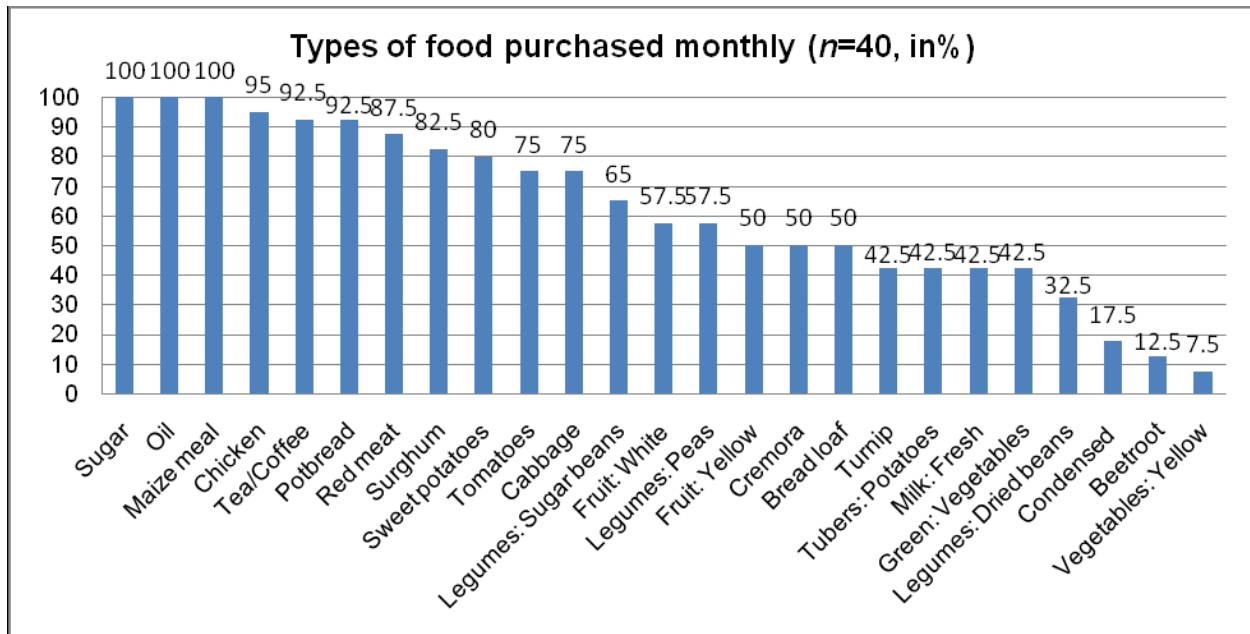

Types of food purchased monthly

Pot bread is the most frequently homemade item (92.5%), as members of the community bake it at home and the bread can be stored for three days. The respondents stated that they believed that they saved money by not buying bread every day. Most people in rural areas do not buy pumpkins as their traditional food. The respondents stated that they obtained their pumpkins from the rural areas, which explains why the percentage of yellow fruit bought is 7.5%. Red meat was found to be cooked twice a week, once during the week and once during the weekend.

Reasons for consuming traditional foods

From the interviews conducted participants cited various reasons for consuming traditional foods. Some cited availability as their main reason since traditional foods are readily ubiquitous. One participant explained:

".....we consume traditional foods because they are readily available hence they are not an expense as compared to retail foods".

The participants had the opportunity to indicate all the reasons why they preferred to eat traditional foods, so that more than one option could be selected. Of the respondents, 63% indicated that they consumed traditional foods because they were nutritious and healthy; 86.3% indicated that they consumed traditional foods because they were tasty; and 13.6% said that they consumed traditional foods because they were readily available. Of the total sample of the Nompumelelo community, 77.2% of the respondents had no other reason for consuming traditional foods apart from the reasons categorised above, and 22.7% gave other reasons why they consumed traditional foods.

Among the reasons given for the consumption of traditional foods in response to the open-ended questions during the focus group discussion were that it was good for people suffering from such diseases as diabetes (1), that it was enjoyable (2), that the respondent had been raised eating them (3), and that they were good for vegetarians. Triangulation was embraced since focus group discussions were used in the findings thus bringing in all the benefits of triangulation in the study.

Associated knowledge of traditional foods

The majority (81.8%) of the participants prepared traditional foods together with other vegetables, and 13.6% prepared the leaves of traditional foods with other vegetables as well. Of the participants, 27.2% stated that they added chicken to their traditional food dishes containing pods, whereas 4.5% added chicken to traditional food dishes containing leaves. Those participants who prepared traditional foods with red meat formed 13.6% of the total, with 9% preparing the leaves of traditional food with red meat. Some (18%) of the participants said that they cooked traditional foods plain, whereas 4.5% prepared traditional foods with either sour milk or yoghurt. The notion of using traditional foods in mixed dishes was evident and fit in well with the cultural practices of rural dwellers, since they also indicated that they used mixed dishes when cooking with traditional leafy vegetables.

Furthermore, traditional foods were said to have other uses, apart from being used as a food source. When asked whether the respondents knew of other uses of traditional foods, apart from their being used as a food source, 36.3% of the participants indicated the affirmative, whereas 63.6% indicated that they did not know of any other uses for traditional foods. Other uses of traditional foods about which the participants knew were revealed during the focus group discussions, and pertained mainly to medicinal uses, including the treatment of certain diseases, and their use to counter water retention. None of the respondents indicated the awareness of the use of traditional foods that was found in the literature review, such as fodder for small ruminants, as seed oil, or as water purification, even when they were prompted to provide more uses than those that they gave during the focus group discussions (Shava, 2000).

All (100%) of the participants interviewed indicated their willingness to recommend traditional foods as a food source to other people. During the focus group discussions, the respondents gave four reasons why they would recommend traditional foods to others food types: 45% of the respondents indicated that they would do so because it was tasty, 20% stated that they would do so on the basis of it being nutritious, 25% noted that they would do so for medicinal reasons, and 10% stated that they would do so because it was readily available.

The information gathered from the interview scheduled on traditional foods administered to the local households provided sufficient findings to support the objective that was set for this portion of the research, namely to establish traditional food usage patterns and the reasons for the use of such food, and to gather associated traditional knowledge.

CONCLUSION

The results provide the support required to introduce highly nutritious food source to the peri-urban role as agents of change and to the traditional Nompumelelo community based on the need to diversify their nutritional intake. The information on indigenous foods gathered from the Nompumelelo community provided the information that traditional foods can assist in dietary diversities as well as food security. The utilization patterns of a community familiar with indigenous foods like wildplum and mushrooms. This raises the potential introduction of mushrooms and wildplum to a traditional group not familiar with wildplum and mushrooms in need of increasing micronutrient intake in their diets. The results provide sufficient evidence to determine the level of acceptability amongst the sample groups according to which they might accept or introduce food source.

REFERENCES

Buffalo City Municipality Integrated Development Plan Review (2003/2004). Retrieved 15 February, 2017, from http://www.buffalocity.gov.za/municipality/idp04_pdf/IDP%20Review%20Revised%20final.pdf.

Callinicos, L. (2004). Oliver Tambo: beyond the Engeli Mountains. Claremont: Seal publishers.

- Drewnowski, A., Henderson, S. A., Levine, A. & Hann, C. (1992). Food preferences in human obesity: carbohydrates versus fats. *Appetite*, 18: 207-221.
- Ferreira, M. (1996). Traditional medicinal use of indigenous plants by older coloureds in the Western Cape. Pretoria: HSRC Publishers.
- Fox, F.W. & Young, M.E.N. (1982). Food from the veld: edible wild plants of Southern Africa. Cape Town: Craighall, Delta Books.
- Kruger, M., Sayed, N. & Kirsten, J. (1998). Composition of South African foods: vegetables and fruits. Medicinal Research Council, 1:1-110.
- Mabongo, D.E.N. (1990). The ethnobotany of the Vhavenda. Unpublished master's thesis. University of Pretoria, Pretoria.
- Mbenyane, X.G., Venter, C.S. & Laker, M.C. (2005). Nutrient intake and consumption of indigenous foods among college students in Limpopo province. *South African Journal of Clinical Nutrition*, 1(18): 32-38.
- Modi, M. & Modi, A.T. (2006). Potential role for wild vegetables in food security: a preliminary case study in KwaZulu-Natal, South Africa. *African Journal of Food, Agriculture, Nutrition and Development*, 6: 1-13.
- Nesamvuni, C.N. (2000). The use and nutritional value of common edible indigenous green leafy vegetables in the diet of the Vhavenda. Unpublished master's thesis. University of the North, Venda.
- Nyembezi, S. & Nxumalo M. (1966). *Imisebeyelanga*. Johannesburg: American Business Express.
- Shava, S. (1999). The use of indigenous plants as food by rural community in the Eastern Cape. Tuku 'A' village. Peddie. South Africa. *South African Journal of Environmental Education*, 19: 85-97.
- Shava, S. (2000). The use of traditional plants as food by rural community in the Eastern Cape: an educational exploration. Unpublished master's thesis. Rhodes University, Grahamstown.
- Sosibo, L. & J. Harvey (2000). *Isizulu: culture of Zulu people*. Pietermaritzburg: Shuter and Shooter. Stayt, H.A. (1968). *The Bavenda*. London: Frank Cass.
- Thompson, L. (2000). *A history of South Africa*. Johannesburg: Jonathan Ball. UNICEF. (2006). Statistics progress for children [online]. Statistics Progress for children [online] Web Page retrieved 04 December, 2006, from <http://www.childinfo.org/areas/malnutrition>. Vos, A.S.D. (1998). *Research at grassroots*. Pretoria:
- Van Schaik. Vos, A.S.D. (2002). *Research at grass roots for the social sciences and human service professions*. Pretoria: Van Schaik.
- Voster, I.H.J. & Rensburg, W.J.V. (2007). The importance of traditional leafy vegetables in South Africa. *African Journal of Food, Agriculture, Nutrition and Development*, 7 (4): 1-25.
- Wehmeyer, A.S. & Rose, E.F. (1983). Important indigenous plants used in the Transkei as food supplements. Pretoria: Botanical Research Institute. Dept of Agriculture and fisheries. 14 (3/4) 613-615.

THE INFLUENCE OF MULTICHANNEL SHOPPING ON HEDONIC SHOPPING VALUE

**Charanya Nopnukulvised
Cardiff Metropolitan University, U.K.**

**Laden Aldin and Gordon Bowen
Regent's University, U.K.**

ABSTRACT

The role of multichannel shopping has changed the way consumers shop. Due to their increased access to information, consumers can choose where to browse, buy or receive their purchases according to their needs. Consumers seek not only utilitarian shopping value (functionality) but also hedonic shopping value (enjoyment) during their shopping experience. As the ability to maintain superior shopping experiences is essential to any business in order to motivate consumers to purchase, it is fundamental that multichannel retailers constantly provide high levels of hedonic shopping value through multichannel shopping. The growth of competitiveness forces retailers to assess their current marketing strategies and their implementation. The ability to add hedonic features is considered a marketing tool to build competitive advantages in the multichannel retail market. Hence, the significance of hedonic shopping value in relation to multichannel shopping cannot be over-estimated. The aim of this paper is to add to the understanding of hedonic shopping value in the context of multichannel shopping. It will explore the existing academic literature on hedonic shopping value, multichannel shopping and related areas.

Keywords: multichannel shopping, hedonic shopping value, channel proliferation.

INTRODUCTION

The Internet has grown and recently shifted towards a multichannel retail strategy. Consumers are becoming more connected with digital media and are therefore making their shopping journeys more sophisticated and complex (Mintel, 2011). Each channel has its own unique strengths (Chatterjee, 2010; Dholakia et al., 2010; Schramm-Klein and Morschett, 2005). Consumers tend to use channels alternatively for the strengths of each channel (Swaid and Wigand, 2012). Hence, consumers may undoubtedly perceive different levels of hedonic shopping value across channels. To be able to improve the shopping experience for multichannel shopping, it is necessary to understand not only consumers' preferences but also how they use channels in order to rapidly adapt to consumers and increase their loyalty, while those companies that fail to do so are likely to lose their customers. The paper's aim is to emphasise the importance of hedonic shopping value in the multichannel shopping context in order to gain competitive advantages. This paper suggests that exploring the hedonic shopping value that consumers derive across channels can enhance understanding of multichannel retailing.

BACKGROUND

Hedonic Shopping Value

Shopping values are the outcome of a shopping experience. Babin et al. (1994) proposed two fundamental dimensions of shopping values, namely hedonic and utilitarian shopping value. Hedonic and utilitarian shopping values have been associated with shopping since they have been used to help explain consumer behaviour such as consumer loyalty (Konus et al., 2008), impulse buying (Dhurup, 2014), consumer satisfaction (Nejati and Moghaddam, 2013), word-of-mouth (Scarpi et al., 2014) and purchase intention (Overby and Lee, 2006).

Babin et al. (1994) defined shopping value as an overall assessment of experiential benefits such as pleasure and entertainment. Hedonic shopping value is more subjective and personal than utilitarian shopping value. Hedonic shopping value derives from exploration and entertainment (Davis, 2013). Hence, increased arousal, fun, fantasy fulfilment, entertainment, freedom and escapism may all indicate hedonically valuable shopping experiences (Babin et al., 1994). Moreover, shopping activity can provide hedonic shopping value with and without consumers making any purchases (Chang, 2001; Irani and Hanzae, 2011).

In contrast, utilitarian shopping value reflects a shopping trip as task-specific, rational and goal-fulfilling (Batra and Ahtola, 1991). Utilitarian value reflects shopping trips as work or missions to be accomplished (Holbrook and Hirschman, 1982). Utilitarian shopping value derives from cost-effectiveness and convenience (Davis, 2013).

Moreover, consumers can perceive both hedonic and utilitarian shopping values at the same time in one shopping experience (Babin et al., 1994). This means that consumers perceive utilitarian value from buying what they need while simultaneously perceiving hedonic shopping value from the enjoyment of the shopping experience itself. Chung (2015) argued that shopping is normally characterised by both values but with different weight depending on the shoppers, products, shopping conditions and their interaction.

Multichannel Shopping

Multichannel shopping has currently become a purchasing pattern in which consumers use multiple channels such as retail Stores, Websites, Television, Catalogues and Mobile to purchase (Goldsmith and Flynn, 2005; Hsiao et al., 2012; van Dijk et al., 2005; Schoenbachler and Gordon, 2002). Multichannel retailing offers many benefits not only to retailers but also to consumers: For retailers, the new online channel can be used to support the entire purchase, and at the same time it can be considered a complementary service for a company (Karimi, 2013). For consumers, the benefits of multichannel shopping help to increase trust and reduce risks that come from online purchasing (Görsch, 2002). For example, consumers can see the products in-store before purchasing online, or they can return items in-store that they purchase online (Görsch, 2002).

Hence, the multichannel retail strategy increases the opportunity to drive traffic and sales across channels (Berman and Thelen, 2004). It means that the greater the number of touchpoints, the more consumers can be reached, and the more effectively consumer needs can be catered for (Berman and Thelen, 2004). Therefore, multichannel shopping helps consumers to step closer to make a purchase (Mintel, 2011). For consumers, the combination of online and offline channels increases levels of convenience and degrees of control now that they can choose different channels for their shopping activities (Görsch, 2002). Schoenbachler and Gordon (2002) stated that for customers, multichannel shopping extends choice of sources of product information, product choices and different ways to obtain the products.

However, not all consumers take advantage of this wider channel choice, as some channels are still not available and some consumers still prefer to shop in traditional stores. Although buying in-store is still the most used route, the Internet is involved in many in-store purchases since some consumers browse online before buying their

apparel in stores (Balasubramanian et al., 2005; Mintel, 2013; Sarkar, 2011). Thus, the distinction between shopping in-store and online has become increasingly blurred (Mintel, 2013).

Channel Proliferation

There are various factors affecting consumers' channel choice. Balasubramanian et al. (2005) discovered that consumers' objectives influence their channel choices. However, their objectives may be different at each stage of a purchase process. They state that the consumers' goals at various stages of the decision process are in accordance with the characteristics of various channels, product and service categories, consumer experiences and knowledge including their preferences for information-presentation formats. Other researchers (such as Black et al., 2002; Chiang et al., 2006; Gupta et al., 2004; Schoenbachler and Gordon, 2002) show similar results regarding factors influencing consumers' channel choices, which are consumer characteristics, product characteristics, channel characteristics and organisational factors. Van Dijk et al. (2005) further add that consumers' channel choice is complex and dynamic. They point out that the preference of their channel choice depends on which channel suits them best and how they can achieve a maximum outcome for the minimum cost.

However, it can be concluded that consumers choose to purchase in a certain channel due to three major factors: convenience, product availability and price (Katawetawaraks and Wang, 2011). Consumers choose to shop where it is convenient for them, either in-store or on a website or mobile or via social media (Hsiao et al., 2012). For example, when shopping from online channels, consumers can shop anywhere at any time without being concerned as to whether the stores are closed (Katawetawaraks and Wang, 2011). Hence, it can be seen that consumers use multichannel shopping to save time and effort (Hsiao et al., 2012). In terms of product availability, consumers may not find specific sizes of products in-store (Mintel, 2011). Therefore, they search for real-time stock availability online and place an order from an online channel instead (Mintel, 2011). In addition, consumers use multichannel shopping to seek special offers (PwC, 2011). They use the benefits of multichannel shopping to compare prices before making a decision about which channel to buy from (PwC, 2011). They think they would make better decisions by comparing prices between offline and online channels (Verhoef et al., 2007). Yet Kwon and Jain (2009) argue that price is not necessarily the main reason for multichannel shopping.

Nevertheless, perceived risks are still a major barrier in online purchase (Katawetawaraks and Wang, 2011; Schröder and Zaharia, 2008). Perceived risks in online commerce are related to the uncertainties consumers feel when they believe that the Internet is unsafe or that there will be negative consequences when they engage with online purchasing (Glover and Benbasat, 2011). Therefore, perceived risks are linked to consumers' trust in online purchase and these risks cause some consumers to be reluctant to purchase from the Internet (Glover and Benbasat, 2011). Those issues may include insecurity of credit card usage (Rosa, 2012; Sarkar, 2011), delayed delivery (Chiu et al., 2014; Rosa, 2012; Sarkar, 2011) or inability to see and try a product on before making a purchase decision (Goldsmith and Flynn, 2005; Yu, 2009).

THE HEDONIC BENEFITS DERIVED FROM EACH CHANNEL

Shopping channels differ in their constraints and advantages, such as whether a channel is used primarily for purchase or for information, whether it is physical or virtual, the degree of accessibility, the type of communication that a channel permits, the nature of its interface, its level of convenience, how easily the consumer is able to switch from one channel to another, the degree of flexibility and the ability to record the history of consumers' behaviour (Dholakia et al., 2010). Hence, some channels are more appropriate for certain situations (Gefen and Straub, 2003).

In Store

Shopping in stores still remains the most popular channel for shopping in multichannel strategies (Balasubramanian et al., 2005; Mintel, 2011; Sarkar, 2011), for the reason that shoppers prefer to have the experience of visiting stores, seeing what new items there are and trying products on as well as substitute products before making a purchase (Falk, 2014). Moreover, consumers can collect the products immediately after they make a purchase without having to wait for a delivery (Berman and Thelen, 2004; Chatterjee, 2010; Falk, 2014). Kim (2002) explains that consumers may go shopping in-store just to get out of their home, to relieve boredom and stress and enjoy being among crowds. According to Nicholson et al. (2002) and Cox et al. (2005), shopping in stores can be seen as a leisure activity. They stated that consumers are excited and motivated by the store atmosphere such as lighting, background music and overall store layout. Therefore, creating a pleasant environment for shopping in-store can motivate consumers to stay longer and return to the store more often (Kim, 2002). Furthermore, Nicholson et al. (2002) and Cox et al. (2005) point out that shopping in stores can change consumers' moods since it can increase opportunities for social interaction, product evaluation and sensory stimulation. Thus, store employees could enhance consumer experience through personal interaction (Cottet et al., 2006; Olsen and Skallerud, 2011). Cox et al. (2005) imply that shoppers enjoy being pampered by store employees due to their personal service. They add that consumers are pleased to be served. Arnold and Reynolds (2003) also state that consumers enjoy shopping in traditional stores because of their need to socialise. Shopping as a social activity can be done only in stores, whereas through other channels it cannot (Berman and Thelen, 2004). Arnold and Reynolds (2003) further pointed out that traditional stores allow consumers to experience pleasure from shopping with friends and family members and bonding with others during shopping trips. Tauber (1972) adds that consumers desire to communicate with others who have similar interests or to affiliate with reference groups since they are likely to express congruent opinions while shopping. On the other hand, some consumers are prefer to have less personal contact with others since they wish to avoid pressure when having face-to-face interaction with store employees. Those who seek anonymous socialisation will go online instead (Balasubramanian et al., 2005).

Finally, the disadvantages of shopping in stores can be seen as overcrowding and queuing to pay, especially in holiday periods, and travel costs (Katawetawaraks and Wang, 2011; Nicholson et al., 2002). Moreover, product information is limited since consumers have to rely on packaging, labels and store employees' knowledge (Noble et al., 2005).

Website

Consumers can now have 24/7 access to the global market and to markets without retail stores (Berman and Thelen, 2004). Furthermore, some of products on websites might not be available in-store (Berman and Thelen, 2004). It can be seen that searching on and purchasing from a website is convenient and easy to do (Kim, 2002). Making a purchase at home and waiting for the products to be delivered to the doorstep are the key that stimulates consumers to shop online (Ramayah and Ignatius, 2005). Moreover, shopping from websites enables consumers to avoid service personnel or social contact when mood is low (Nicholson et al., 2002). Websites provide consumers with a wide range of information and are easy to access (Noble et al., 2005). Hence, websites are commonly used to search about product features and to compare offers and prices across online retailers (Berman and Thelen, 2004; Chatterjee, 2010; van Dijk et al., 2005). In addition, the application of technology on websites can now provide atmosphere in much the same way as traditional stores through colour, music and light (Menon and Kahn, 2002). Interactive features such as image enlargement, mix-and-match facilities, three-dimensional virtual models and virtual fitting rooms allow consumers to have actual experience with the products (Lee et al., 2010). The technological advances can create positive website shopping experiences and decrease perceived risks from website shopping (Blázquez, 2014; Cai and Xu, 2011).

However, the disadvantages of websites include the inability to see the products before purchasing, poor quality illustrations of products, delayed delivery, products not meeting with expectations (size, fabric, colour), unclear product description, lack of human contact and transaction-related risks (Kim, 2002; Mintel, 2014; Nicholson et al., 2002).

Catalogue

The benefit of printed catalogues is their portability (Berman and Thelen, 2004). Catalogue shopping is convenient since consumers can shop anywhere at any time of the day (Goldsmith and Flynn, 2005). They are easy to read and can be picked up repeatedly (Nicholson et al., 2002). Consumers see catalogues as relaxing reading in their leisure time (Nicholson et al., 2002). Catalogues are often seen as lookbooks to get ideas about product information (Rud and Wong, 2011). Catalogue shopping can be a resource to inspire consumers or to interest them in products they would not have had in mind beforehand (Rud and Wong, 2011). Moreover, Fiore (2002) explains that shopping via catalogues provides sensory and affective pleasure through colourful pictures, and that catalogues are able to stimulate consumers to imagine themselves using the products.

Although the advantages of catalogue shopping are convenience, 24/7 ordering capacity, ability to access the global market and markets without retail stores, these advantages are the same as online. Besides, there is some evidence that shows the decline of shopping via catalogues in traditional post-based mail order since consumers often channel-shift from catalogue to online channel (Goldsmith and Flynn, 2005). Nevertheless, printed catalogues can be used to stimulate consumers to purchase through online shopping or in-store shopping (Mintel, 2011). However, the amount of information provided in catalogues is restricted (Noble et al., 2005). Catalogues make less information available to consumers compared to the Internet (Noble et al., 2005). Therefore, consumers might find that the information provided in catalogues does not meet their needs (Noble et al., 2005).

Mobile

Mobile is the closest channel to consumers since the mobile phone is a portable device which is easy to carry around. Consumers are able to use mobiles instantly and more frequently compared to personal computers (Lu and Su, 2009). The unique characteristic of shopping via mobile is that consumers can access online anywhere and at any time while they are on the move or even in severe time constraints such as while waiting for their friends or in a traffic jam (Lu and Su, 2009; Yang and Kim, 2012). The ability to search for information while shopping is another reason why mobile shopping is different from shopping from websites (Yang and Kim, 2012). Consumers use their smartphones and tablets to log into mobile sites and mobile applications to find information such as product details, opening times, store locations and latest offers, whether they are in-store or not (Falk, 2014). Moreover, mobile devices, especially tablet computers offering good screen size, are easy to hold and browse, have a touchscreen interface and click-to-order features that can enhance consumer experience (Mintel, 2011). Consumers can enjoy the fun through the features in mobile applications and the easy-purchase experience (Chen et al., 2009). Bruner and Kumar (2005) agreed that the enjoyment from mobile shopping comes from the ease of use and the sense of control. However, the limitations of mobile commerce are still found to be a small screen and limited data processing capacity and network connection (Yang and Kim, 2012; Lu and Su, 2009).

Social Media

Social commerce is a new channel which merges e-commerce with social media (Anderson et al., 2011). Social media not only provides a platform to stay in contact with family and friends, but it is also a place where consumers can stay tuned to their favourite brands (Ramlugun, 2014). Hence, social media such as *Facebook*, *Twitter* and *Instagram* can be used to become informed about news and trends (Jain, 2014). Marketers and retailers use social media to reach their consumers and provide stores to their customers (Ramlugun, 2014). Social media allows consumers to browse and place orders easily at any time and at a reduced cost (Cha, 2009). This is because social media provides consumers with a wide variety of products, which makes their information search and product selection easier (Paquette, 2013). The more that consumers perceive shopping via social media to be useful and easy to use, the more likely they are to be willing to shop on social media sites (Cha, 2009). Consumers perceive arousal from the trend of discovering new fashions, products and brands in this way (Mikalef et al., 2013). Furthermore, Ramlugun (2014) points out that product browsing via social media creates a sense of adventure. This is because social media platforms effortlessly provide non-stop updates of the latest products in contrast to traditional stores.

Consumers are able to exchange and share messages in real time, such as posting, sharing pictures and comments and peer support with their networks (Pozza, 2014; Ramlugun, 2014). Since social media allows consumers to communicate directly with retailers, they can ask for information about products and report problems with products and services via social media (Paquette, 2013). In addition, retailers use social media to support in-store activities, which in turn boosts traffic and sales. Furthermore, consumers tend to share information with their friends after browsing (Paquette, 2013; Mikalef et al., 2013; Shankar et al., 2011). Hence, word-of-mouth or, in this case, positive feedback from a peer about a product is a strong motivator for future purchasing. On the contrary, however, negative comments and feedback including product reviews from social media will subsequently affect consumers' decision-making (Pfeffer et al., 2014). Social media has become an essential tool for retailers to build relationships with consumers (Pozza, 2014). The wide range of consumers utilising social media means that most target markets can be reached (Cha, 2009). Retailers use social media to enhance their brand image, for targeting advertising and creating social interaction and social networking with other social network members so as to reach potential buyers (Kang et al., 2014; Saravanakumar and SuganthaLakshmi, 2012). In addition, retailers employ social media to promote their brands and share promotions. Therefore, shoppers can share products with their friends via social media and save them to purchase later (Mintel, 2014). Hence, the influence of social media motivates shoppers to buy products (Mintel, 2014).

FUTURE RESEARCH

Since the aim of this paper is based on the academic literature, it could be developed further with empirical data. Future research could further investigate current perceptions of each channel. What do consumers expect from each channel and why do they choose to purchase in certain channels rather than others? A recommendation for future research is to explore how different channels complement each other. Which channel is most popular for each product category and which channels do consumers tend to avoid? Future research could also focus on certain product categories such as apparel, luxury products or cosmetics. Such research could provide benefit and insight relating to hedonic shopping value and multichannel shopping.

This paper is limited to only five channels in the multichannel strategy (in-store, website, catalogue, mobile and social media) and it does not consider other forms of multichannel shopping such as ordering by phone or television shopping. The market research of Mintel (2011) shows that television shopping and ordering by phone are less popular in the multichannel shopping service. This paper therefore assumes that consumers commonly purchase from these five channels. Future research could further probe this area in order to understand why consumers use or do not use various channels to shop, and this may well offer new insights into multichannel retailing.

CONCLUSION

The challenge for the multichannel strategy is to understand clearly how consumers use or evaluate different channels to purchase from. Hence, understanding the strengths and weaknesses of each channel is crucial in multichannel retail as this will aid strategic thinking in order to gain more sales in certain channels. Multichannel retailers need to constantly monitor their services and it is very important for them to provide high levels of hedonic shopping value through the multichannels to motivate consumers to purchase. At the same time, the negative perceptions of each channel have to be minimised.

REFERENCES

- Anderson, M., Sims, J., Price, J., & Brusa, J. (2011). Turning 'like' to 'buy' social media emerges. *Strategy &*, 1–12.
- Arnold, M.J. & Reynolds, K.E. (2003). Hedonic shopping motivations. *Journal of Retailing* 79(2), 77–95. Available at: <http://linkinghub.elsevier.com/retrieve/pii/S0022435903000071> [Accessed: 24 May 2014].
- Babin, B.J., Darden, W.R., & Griffin, M. (1994). Work and/or fun: measuring hedonic and utilitarian shopping value. *Journal of Consumer Research* 20(4), 644–657.
- Balasubramanian, S., Raghunathan, R., & Mahajan, V. (2005). Consumers in a multichannel environment: Product utility, process utility, and channel choice. *Journal of Interactive Marketing* 19(2), 12–30. Available at: <http://dx.doi.org/10.1002/dir.20032>.
- Batra, R. & Ahtola, O.T. (1991). Measuring the hedonic and utilitarian sources of consumer attitudes. *Marketing Letters* 2, 159–170.
- Berman, B. & Thelen, S. (2004). A guide to developing and managing a well-integrated multi-channel retail strategy. *International Journal of Retail & Distribution Management* 32(3), 147–156.
- Black, N.J., Lockett, A., Ennew, C., Winklhofer, H., & McKechnie, S. (2002). Modelling consumer choice of distribution channels: an illustration from financial services. *International Journal of Bank Marketing* 20(4), 161–173.
- Blázquez, M. (2014). Fashion shopping in multichannel retail: the role of technology in enhancing the customer experience. *International Journal of Electronic Commerce* 18(4), 97–116. Available at: <http://mesharpe.metapress.com/app/home/contribution.asp?referrer=parent&backto=issue,5,7;journal,1,56;linkingpublicationresults,1:106045,1>.
- Bruner, G.C. & Kumar, A. (2005). Explaining consumer acceptance of handheld Internet devices. *Journal of Business Research* 58(5), 553–558.
- Cai, S. & Xu, Y. (2011). Designing not just for pleasure: effects of web site aesthetics on consumer shopping value. *International Journal of Electronic Commerce* 15(4), 159–188.
- Cha, J. (2009). Shopping on Social networking web sites: attitudes toward real versus virtual items. *Journal of Interactive Advertising* 10(1), 77–93. Available at: <http://jiad.org/download?p=126>.
- Chang, E. (2001). *The Mediating Role of Hedonic Shopping Value in Apparel Shopping Satisfaction*. Oregon State University.
- Chatterjee, P. (2010). Multiple-channel and cross-channel shopping behavior: role of consumer shopping orientations. *Marketing Intelligence & Planning* 28(1), 9–24. Available at: <http://www.emeraldinsight.com/10.1108/02634501011014589> [Accessed: 23 October 2014].
- Chen, X., Li, M. & Fang, Q. (2009). Factors influencing consumption experience of mobile device: A study from experiential view. *Proceedings of the International Conference on Electronic Business (ICEB) (70973077)*, pp. 701–710.
- Chiang, W.K., Zhang, D., & Zhou, L. (2006). Predicting and explaining patronage behavior toward web and traditional stores using neural networks: a comparative analysis with logistic regression. *Decision Support Systems* 41(2), 514–531. Available at: <http://dx.doi.org/10.1016/j.dss.2004.08.016>.
- Chiu, C.-M., Wang, E.T.G., Fang, Y.-H., & Huang, H.-Y. (2014). Understanding customers' repeat purchase intentions in B2C e-commerce: the roles of utilitarian value, hedonic value and perceived risk. *Information Systems Journal* 24(1), 85–114. Available at: <http://doi.wiley.com/10.1111/j.1365-2575.2012.00407.x> [Accessed: 9 October 2014].
- Chung, Y.-S. (2015). Hedonic and utilitarian shopping values in airport shopping behavior. *Journal of Air Transport Management* 49, 28–34. Available at: <http://www.sciencedirect.com/science/article/pii/S0969699715000939>.

- Cottet, P., Lichtlé, M.C., & Plichon, V. (2006). The role of value in services: a study in a retail environment. *Journal of Consumer Marketing* 23(4), 219–227.
- Cox, A.D., Cox, D., & Anderson, R.D. (2005). Reassessing the pleasures of store shopping. *Journal of Business Research* 58(3 SPEC. ISS.), 250–259.
- Davis, L. (2013). Exploring Chinese consumers' shopping value across retail outlets. *International Journal of China Marketing* 14(1), 51–64.
- Dholakia, U.M., Kahn, B.E., Reeves, R., Rindfleisch, A., Stewart, D., & Taylor, E. (2010). Consumer behavior in a multichannel, multimedia retailing environment. *Journal of Interactive Marketing* 24, 86–95.
- Dhurup, M. (2014). Impulsive fashion apparel consumption: the role of hedonism, fashion involvement and emotional gratification in fashion apparel impulsive buying behaviour in a developing country. *Mediterranean Journal of Social Sciences* 5(8), 32–38. Available at: <http://www.mcser.org/journal/index.php/mjss/article/view/2530%5Cnhttp://www.mcser.org/journal/index.php/mjss/article/view/2544>.
- van Dijk, G., Laing, A., & Minocha, S. (2005). Consumer behaviour in multi-channel retail environments: consumer movement between online and offline channels. In: *5th American Marketing Association/Academy of Marketing Joint Biennial Conference 'Marketing: Building Business, Shaping Society'*. Dublin.
- Falk, J. (2014). *Physical Mobile Interaction in Omni-Channel Retailing: Using the customers' smartphone to interact with smart objects in a store*. Linköping University.
- Fiore, A.M. (2002). Effects of experiential pleasure from a catalogue environment on approach responses toward fashion apparel. *Journal of Fashion Marketing and Management: An International Journal* 6(2).
- Goldsmith, R.E., & Flynn, L.R. (2005). Bricks, clicks, and pix: apparel buyers' use of stores, internet, and catalogs compared. *International Journal of Retail & Distribution Management* 33(4), 271–283. Available at: <http://www.emeraldinsight.com/10.1108/09590550510593202> [Accessed: 9 October 2014].
- Görsch, D. (2002). Multi-channel integration and its implications for retail web sites. *Ecis* (2002), 748–758. Available at: <http://aisel.aisnet.org/ecis2002/11>.
- Gupta, A., Su, B.C., & Walter, Z. (2004). Risk profile and consumer shopping behavior in electronic and traditional channels. *Decision Support Systems* 38, 347–367.
- Holbrook, M.B., & Hirschman, E.C. (1982). The experiential aspects of consumption: consumer fantasies, feelings, and fun. *Journal of Consumer Research* 9, 132.
- Hsiao, C.-C., Yen, H.J.R., & Li, E.Y. (2012). Exploring consumer value of multi-channel shopping: a perspective of means-end theory. *Internet Research* 22(3), 318–339. Available at: <http://www.emeraldinsight.com/10.1108/10662241211235671> [Accessed: 25 May 2014].
- Irani, N. & Hanzae, K.H. (2011). The mediating role of hedonic value in apparel shopping satisfaction. *World Applied Sciences Journal* 12(3), 1715–1729.
- Jain, V. (2014). *The Impact of Social Commerce on Consumer Behaviour: with special reference to F-commerce*. Dayalbagh Educational Institute.
- Kang, J.-Y.M., Johnson, K.K.P., & Wu, J. (2014). Consumer style inventory and intent to social shop online for apparel using social networking sites. *Journal of Fashion Marketing and Management* 18(3), 301–320. Available at: <http://www.emeraldinsight.com/10.1108/JFMM-09-2012-0057>.
- Karimi, S. (2013). *A purchase decision-making process model of online consumers and its influential factor: A cross sector analysis*. University of Manchester.
- Katawetawarak, C. & Wang, C.L. (2011). Online shopper behavior. *Influences of Online Shopping Decision* 1(2), 66–74.
- Kim, Y.-K. (2002). Consumer value: an application to mall and Internet shopping. *International Journal of Retail & Distribution Management* 30(12), 595–602.

- Konus, U., Verhoef, P., & Neslin, S. (2008). Multichannel shopper segments and their covariates. *Journal of Retailing* 84(4), 398–413. Available at: <http://www.sciencedirect.com/science/article/pii/S0022435908000675> [Accessed: 15 July 2014].
- Kwon, K.-N. & Jain, D. (2009). Multichannel shopping through nontraditional retail formats: variety-seeking behavior with hedonic and utilitarian motivations. *Journal of Marketing Channels* 16(2), 149–168. Available at: <http://www.tandfonline.com/doi/abs/10.1080/10466690802477418> [Accessed: 25 May 2014].
- Lee, H.-H., Kim, J. & Fiore, a. M. (2010). Affective and cognitive online shopping experience: effects of image interactivity technology and experimenting with appearance. *Clothing and Textiles Research Journal* 28(2), 140–154.
- Lu, H.-P. & Su, P.Y.-J. (2009). Factors affecting purchase intention on mobile shopping web sites. *Internet Research* 19(4), 442–458.
- Menon, S. & Kahn, B. (2002). Cross-category effects of induced arousal and pleasure on the Internet shopping experience. *Journal of Retailing* 78(1), 31–40.
- Mikalef, P., Giannakos, M., & Pateli, A. (2013). Shopping and word-of-mouth intentions on social media. *Journal of Theoretical and Applied Electronic Commerce Research* 8(1), 17–34.
- Mintel (2013). *Clothing Retailing*.
- Mintel (2014). *E-commerce*.
- Mintel (2011). *Multi-Channel Retailing*.
- Nejati, M. & Moghaddam, P.P. (2013). The effect of hedonic and utilitarian values on satisfaction and behavioural intentions for dining in fast-casual restaurants in Iran. *British Food Journal* 115(11), 1583–1596. Available at: <http://www.emeraldinsight.com/10.1108/BFJ-10-2011-0257>.
- Nicholson, M., Clarke, I. & Blakemore, M. (2002). ‘One brand, three ways to shop’: situational variables and multichannel consumer behaviour. *The International Review of Retail, Distribution and Consumer Research* 12(2), 131–148. Available at: <http://www.tandfonline.com/doi/abs/10.1080/09593960210127691> [Accessed: 27 May 2014].
- Noble, S.M., Griffith, D. A. & Weinberger, M.G. (2005). Consumer derived utilitarian value and channel utilization in a multi-channel retail context. *Journal of Business Research* 58(12), 1643–1651.
- Olsen, S.O. & Skallerud, K. (2011). Retail attributes’ differential effects on utilitarian versus hedonic shopping value. *Journal of Consumer Marketing* 28(7), 532–539.
- Overby, J.W. & Lee, E.J. (2006). The effects of utilitarian and hedonic online shopping value on consumer preference and intentions. *Journal of Business Research* 59, 1160–1166.
- Paquette, H. (2013). *Social Media as a Marketing Tool: A literature review*. Major papers by Master of Science students. Paper 2.
- Pfeffer, J., Zorbach, T., & Carley, K.M. (2014). Understanding online firestorms: negative word-of-mouth dynamics in social media networks. *Journal of Marketing Communications* 20(March 2015), 117–128. Available at: <http://www.tandfonline.com/doi/abs/10.1080/13527266.2013.797778>.
- Pozza, I.D. (2014). Multichannel management gets ‘social’. *European Journal of Marketing* 48(7/8), 1274–1295. Available at: <http://www.emeraldinsight.com/doi/abs/10.1108/EJM-10-2012-0598> [Accessed: 15 October 2014].
- PwC 2011. *Pick ‘n’ Mix: Meeting the demands of the new multi-channel shopper*.
- Ramayah, T. & Ignatius, J. (2005). Impact of perceived usefulness, perceived ease of use and perceived enjoyment on intention to shop online. *ICFAI Journal of Systems Management (IJSM)*, 1–16. Available at: <http://ramayah.com/journalarticlespdf/impactpeu.pdf>.
- Ramlugun, V.G. (2014). The scope of social media browsing and online shopping for mauritian e-retailers: a study based on utilitarian and hedonic values. *Review of Integrative Business and Economics Research* 3(2), 219–241.

- Rosa, M.I. (2012). *Omni-channel retailing: Is 'Order online pick-up in store' service viable in the Portuguese grocery industry?* Universidade Católica Portuguesa.
- Rud, M. & Wong, S.K.B. (2011). *Turning a New Page: Co-creation in Practice through the Study of C-G Lookbook*. Lund University.
- Saravanakumar, M. & SuganthaLakshmi, T. (2012). Social Media Marketing. *Life Science Journal* 9(4), 2012.
- Sarkar, A. (2011). Impact of utilitarian and hedonic shopping values on individual's perceived benefits and risks in online shopping. *International Management Review* 7(1), 58–65. Available at: http://uxscientist.com/public/docs/uxsci_50.pdf [Accessed: 9 October 2014].
- Scarpi, D., Pizzi, G. & Visentin, M. (2014). Shopping for fun or shopping to buy: Is it different online and offline? *Journal of Retailing and Consumer Services* 21(3), 258–267. Available at: <http://www.sciencedirect.com/science/article/pii/S0969698914000204> [Accessed: 11 July 2014].
- Schoenbachler, D.D. & Gordon, G.L. (2002). Multi-channel shopping: understanding what drives channel choice. *Journal of Consumer Marketing* 19, 42–53.
- Schramm-Klein, H. & Morschett, D. (2005). Multi-channel retailing. *Journal of Internet Banking and Commerce* 10. Available at: <http://www.arraydev.com/commerce/jibc/2005-02/schramm-klein.htm>.
- Schröder, H. & Zaharia, S. (2008). Linking multi-channel customer behavior with shopping motives: an empirical investigation of a German retailer. *Journal of Retailing and Consumer Services* 15, 452–468.
- Shankar, V., Inman, J.J., Mantrala, M., Kelley, E., & Rizley, R. (2011). Innovations in shopper marketing: current insights and future research issues. *Journal of Retailing* 87(SUPPL. 1), S29–S42. Available at: <http://dx.doi.org/10.1016/j.jretai.2011.04.007>.
- Swaid, S.I. & Wigand, R.T. (2012). The effect of perceived site-to-store service quality on perceived value and loyalty intentions in multichannel retailing. *International Journal of Management* 29(3), 301–314.
- Tauber, E.M. (1972). Why do people shop? *Journal of Marketing* 36, 46–49. Available at: <http://www.jstor.org/stable/1250426>.
- Verhoef, P.C., Neslin, S. A., & Vroomen, B. (2007). Multichannel customer management: Understanding the research-shopper phenomenon. *International Journal of Research in Marketing* 24(2), 129–148. Available at: <http://linkinghub.elsevier.com/retrieve/pii/S0167811607000134> [Accessed: 26 May 2014].
- Yang, K. & Kim, H.-Y. (2012). Mobile shopping motivation: an application of multiple discriminant analysis. *International Journal of Retail & Distribution Management* 40(10), 778–789. Available at: <http://www.emeraldinsight.com/journals.htm?issn=0959-0552&volume=40&issue=10&articleid=17050974&show=html>.
- Yu, U. (2009). *Relationship of Body Satisfaction to Virtual Product Experience and Perceived Risk of Product Performance in Online and Multi-Channel Apparel Shopping*. Iowa State University.

CORPORATE SOCIAL RESPONSIBILITY AS DRIVER OF SUSTAINABLE DEVELOPMENT IN HOST COMMUNITY

Eveth Nwobodo-Anyadiegwu, Charles Mbohwa
University of Johannesburg, South Africa

ABSTRACT

The traditional view that profit optimisation, for companies, should be prioritising, at the expense or neglect of socio ecological needs no longer holds in political, environmental or economic discourse. Corporate Social Responsibility (CSR) encompasses socio economic contributions of business towards host community and society. Such responsibilities include preservation of its environmental, provision of pro-social amenities to host communities and corporate behaviour that is considered ethical. The objective of this paper is to examine stakeholder relationship for effective CSR and sustainable development. Furthermore, the paper identifies factors that undermine effective implementation of CSR projects by corporates in their operating communities. The paper underscores a proactive approach to stakeholder management in CSR community projects.

Keywords: CSR, community projects, Sustainable development, mining, Multinational companies (MNCs), sub-Saharan African countries.

INTRODUCTION

There is apparent reduction in the ability of governments across developing and under-developed countries, particularly in sub-Saharan Africa countries to provide the entire citizenry with sustainable socio-economic development. This has been exacerbated by consistently high level of poverty, deepening inequality and rising unemployment. In the face of these challenges, business can no longer confine itself solely with profit-making activities, but assist governments in promoting sustainable developmental programmes in both their host communities and the entire society. Business is therefore expected to achieve this societal objective by means of corporate social responsibility (CSR) initiatives.

The CSR thesis presupposes that business objectives should go beyond profit maximization to include enhancing societal welfare (Idemudia 2014 a)). As an act of accountability, CSR is a company's self-assurance that it is operating as a responsible corporate citizen. It is an image or goodwill which an organization demonstrate to society voluntarily, or sometimes by compulsion in response to societal pressure (Akpala, 1990). The definition by Akpala presents CSR as a totality of all impression of an organization on its variance public (i.e. both internal and external stakeholders). Business rely on good reputation and public perception in order to sustain profitability and still be considered as a responsible corporate citizen by society (Roberts & Dowling 2002). The scope of these definitions has been broadened by other literature such as the World Business Council for Sustainable Development (WBCSD) which emphasised the social progressive nature of CSR as "business commitment to contribute to sustainable economic development, working with employees, their families, the local community, and society at large to improve their quality of life" (WBCSD, 2006). Similarly, the European Commission describes CSR as a "concept, whereby companies integrate social and environmental concerns into their business operations and interactions with their stakeholders on a voluntary basis" (Commission of the EU Communities, 2001). There is therefore an expectation that corporates, as legal entities would show concern and assume responsibility for their actions towards different stakeholders – employees, public, suppliers, debtors, customers, host community; and environment (Lambertini & Tampieri, 2015).

The adventure of multinational companies into some parts of African countries, particularly those endowed with mineral resources date back to the 19th Century. Their operations in these countries are usually

characterised by environmental pollution including severe damage to ecological composition of the host communities (Conde, & Le Billon, 2017) is of global concern. In similar circumstances, many communal lands were acquired by multinational companies leading to displacement of local inhabitants who are left destitute with no means of economic livelihood and degraded environment. Furthermore, the fate of mining communities upon mine closure remains a subject of controversy, rift and conflict, as mining communities are reduced to ghost towns (Littlewood, 2014). The resulting ecological and economic deprivation occasioned by the commercial activity of corporate organisations operating in these communities have fostered a compelling realization of the need to initiate CSR programmes that could address various problems that have resulted from their operations. Redressing the damaging effects of commercial operation in various communities by corporations have, as a matter of expediency necessitated for ‘sustainable development’ angle. This concept has been defined as any developmental programme that is capable of addressing the present needs of society without conceding the ability of meeting forthcoming generations’ needs and aspirations (World Commission on Environment and Development, 1987). Such programmes fall within the broad context of health, education, poverty alleviation, environmental and ecological protection, human capital development and others. While previous literature has provided evidence of businesses engaging in social responsibility programmes in Africa (Visser, 2005; Fourie & Eloff, 2005), there still exists the need to relate CSR initiatives to pragmatic, inclusive and sustainable socio-economic development in African countries. This necessity therefore represents the core objective of this paper. Against this background, the paper attempts to examine, through the stakeholder theory why MNCs in mining industry are not achieving sustainable development through CSR projects in some African communities. Furthermore, we highlight factors that influence the extent of company’s commitment to CSR. The paper concludes by recommending a proactive approach to CSR projects stakeholder management rather than reactive.

Nexus between CSR and sustainable development

An economic question that initially defined discussions on CSR was whether business has any responsibility towards society other than its legal obligation. This question arose from the views expressed by different schools of thoughts. While Carroll (1991) operationally classified CSR into four distinct dimensions as: economic, ethical, legal and philanthropic responsibilities, the neoclassical economic view argued that the only business of business is to do business. Accordingly, Friedman (1962) asserted that “There is one and only one social responsibility of business - to use its resources and engage in activities to increase its profits so long as it stays within the rules of the game, which is to say, engages in open and free competition, without deception or fraud” (Friedman, 1962). This view is partially supported by Hahn (2011) who argued that while business could engage in social responsibilities, their engagement should be motivated by economic rationality. Other authors have provided context to the concept of CSR from an obligatory perspective. For example, Kok et al. (2001) define CSR to involve obligation of the firm to use its resources to society advantage as a committed corporate citizen and through visible participation as a member of the society, and with the aim of improving welfare of society at large at no commercial profit. This participatory approach between corporates and other stakeholders has generally positioned the stakeholder theory as a useful framework in the articulation of CSR (Snider et al., 2003).

The neoclassical economists’ view has been criticised by both the proponents of CSR and sustainable development. While the latter recognised economic dimension as important, they argued that a corporates also has contend with the challenge of social and responsibilities (Ebner & Baumgartner, 2006). This contention is consistent with an earlier view expressed by Wood (1991) who asserted that “the basic idea of corporate social responsibility is that business and society are interwoven rather than distinct entities; therefore, society has certain expectations for appropriate business behaviour and outcomes” (Wood, 1991). Payne and Raiborn (2001) also argued that without sustainable development, there would not be a long-term future for either business or the society. The argument by Payne and Raiborn could be further located within the context of ‘corporate sustainability’ which Dyllick and Hockerts (2002) defined as the responsibility of a firm to meet the current direct and implied needs of its stakeholders without conceding its ability to meet upcoming stakeholders needs of as well. In achieving this objective, firms need to maintain and develop their ecological, economic, and social capital base while at the same time actively contributing to a sustainable political system. Dyllick and Hockerts further reiterated the need for companies to be socially sustainable in order to enable them add value to the communities in which they do business. This they could do by increasing the human capital of each stakeholders, in addition to furthering the operating community’s social objectives. Furthermore, literature does not provide a

consensus on the question as to whether CSR should be strictly defined as a voluntarily concept or an approach which should be regulated and enforceable (Hopkins, 2005). However, the concept has been primarily categorised by Carroll (1991) as discussed in the following section.

Dimensions of CSR

Carroll's corporate social performance model epitomises the central focus of this paper – that a company's social responsibility should not be distinctively separated from financial performance as both belong to the total social responsibilities of companies (Carroll 1979). The model represents a shift in the managerial mindset from the perception that CSR is just charity. – *benevolence to society which corporates should demonstrate willingly*. Carroll (1991) operationally classified CSR into four distinct responsibility dimensions - philanthropic, economic, ethical and legal.

Table 1: Adapted from Carroll's (1991) Corporate Social Responsibility Model

CSR Classification	Attention	Requirements
Philanthropic	Demonstrate moral responsibility toward socio-economic empowerment of their community.	Wanted by corporate and individual business pioneers.
Ethical	Conduct business in a manner that is fair and protective of people and environment	Required from corporates by society
Legal	Do not violate the law. Adherence to society's terms of right and wrong.	Legal requirement for corporate conformance to the law.
Financial	Be responsive to financial obligations - profitability	Fundamental requirement by shareholders.

The economic dimension of CRS addresses a financial obligation which businesses owe investors. This requirement is fundamental since the company must make profit to survive and achieve sustainability growth (Freeman, 1984). The early capitalism philosophy supports this school of thought. Hence, they advocate that the main objective of business should be profit maximization (Friedman Sundaram & Inkpen, 2004) without which it may be impossible to fulfil legal obligations like paying tax and other business expenses (Samuel & Mqomboti 2017).

A South African contextual study by Samuel and Mqomboti (2017) has extended Carroll's dimensions to include cultural and consultative approaches in order to achieve a 'negotiated CSR projects' that would be acceptable to both the giver (corporates) and receiver (community). The authors' argument is against the backdrop of disputes, rejection, resistance and in some cases, protests and violence by host communities that often characterize CSR initiatives by businesses. To this extent, the concept of sustainability is naturally derived from the stakeholder theory. Stakeholder theory affirms that people who are affected or influenced by a corporation operations hold a right and obligation to partake it (Freeman, 1984). Stakeholders are traditionally classified as primary or secondary (Clark, 1995) and on basis of level of influence and interest (Snyder, 2014). Unfortunately, impoverished communities are not acknowledged as deserving managerial consideration in decision making as they are perceived as stakeholder with no legitimacy, urgency and power (see Mitchell et al. 1997 in Idemudia (a) 2014 p. 427). Contrary to this view, Zambon and Del Bello (2005) argue that without identifying the needs of the stakeholders (particularly host community); it will be impossible for corporates to act in a socially responsible manner.

A Stakeholder Integration Perspective

Jones (1995) postulates that trusting and accommodating help corporates resolve problems associated with opportunism in their contractual relationship with stakeholders. The critical role of stakeholder management is to identify, describe, fathom, analyse and manage Carroll (1991). Influenced by Carroll's model and Jones (1995) Instrumental Stakeholder theory; the following are recommended for CSR community projects engagement:

- Identify *key stakeholders* – who are the stakeholders?
- Understand *their interest*, attitude, and culture - What are their stakes?

- Perform *SWOT analysis of stakeholder relationship* -What are our strength and weaknesses on the merit of the opportunities and challenges presented in the stakeholder relationship?
- Conduct *needs analysis*. What social responsibilities (ecological, philanthropic, legal, and ethical) do we owe our stakeholders? Which specific projects will serve the needs? (Carroll's model)
- Set *strategic priorities to enhance stakeholder's support*
- Identify the most *effective approach for stakeholder engagement*; review the process to strengthen engagement capacities.
- Pursue *best project management practices* in the project implementation.

Although the steps are iterative, they are also sequential and continuous. Stakeholders' involvement can be viewed as a requirement as well as a benefit. Accordingly, stakeholder management should not be used as a tool for acquiring social acceptance, or gaining approval for a decision taken somewhere outside public scrutiny.

Sustainable development projects in African countries

As reiterated by Cash (2012) (see Idemudia 2014 (a), Transnational companies (TNCs) are not development organizations and therefore must not be expected to spearhead developmental itinerary. However, CSR debate in Africa, in relation to underdevelopment, hinges on the role of corporates in providing solution rather than being the cause of the problem (Idemudia, 2015). While many MNCs mineral exploration companies in Africa has made substantive CSR investment, quantifiable dividend in the nature of durable social amenities that consistently serve the need it was intended to is still an illusion in many instances (Idemudia 2014 (a); Littlewood 2015). Why are corporates not achieving sustainable development through CSR projects? Recent literature record cases in Nigeria, Namibia, Sierra-Leon, Kenya and Ghana to mention but a few (Littlewood 2015; Le, D 2016; Dartey et al 2015).

Nigerian government has been preoccupied with revenue earnings from crude oil, without visible concern for ecological degradation of the region that sustains the economy of the country (Ibeanu, 2000). Despite the natural endowment of this region, extant literature corroborates the deplorable environmental condition and poor standard of living prevailing within the Niger Delta region (Agbu, 2005; Ebegbulem et al., 2013: 280; Eweje, 2006: 27–56; Jike, 2004: 686–701; Obi, 1999 in Gonzalez 2016:). Iterated by indigenes (Uche 2010 p.2) has written, '*previously cultivated lands have been rendered useless by oil spills. The arable lands yet to be impacted have become devoid for nutrients due to over use. Aquatic organisms including fish are no longer in abundance due to water pollution with hydrocarbons... These have hence cut down fish production to the extent that fishing as a profitable venture is in decline. The air is polluted with noxious gases from gas flare points, constituting unquantifiable health hazards*'. A situation which many has tagged an environmental genocide. The plight of the Niger Delta is a classic case of "natural resource curse" (Gonzalez 2016 p.510) TNCs has been operating in the oil rich Niger Delta since 1960 and embrace the awareness of executing various (CSR) projects in their host communities. Dandago and Arugu (2014) in their empirical study investigated whether CSR project in the Niger Delta by multinational oil companies fulfil the anticipated social economic needs. From a survey of some of the communities, they posit that, these projects do not address sustainability needs of communities as they are born out of short-range expediency, more or less to secure social authorization to operate. Their CSR tend towards advancing their business optimization agenda rather than environmental rehabilitation and enduring development that can empower locals, and ensure lasting improvement to their quality of life.

Fig 1: Sustainable development achieved through CSR

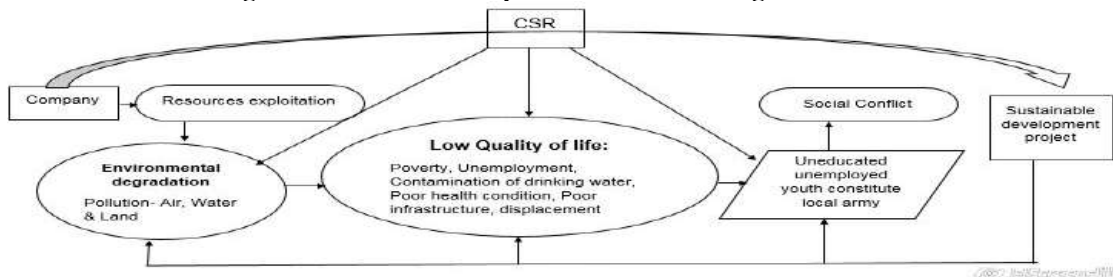

Source: Authors

Evident in these communities are litany of poor quality social amenities and abandoned structures of unfinished projects, dysfunctional facilities – schools that are not refurbished, hospitals that are neither staffed or equipped (Idemudia, 2014 (a) (b)). Given their present status, Dandago & Arugu (2014) concluded that TNC in Niger delta have not deliver the much-anticipated sustainable development of the region through CSR projects. Perusing through existing theoretical and empirical literature, some factors has been signalled as having influence on the extent of company's commitment to CSR.

Managerial values and corporate governance within the company

Business can make better impact on the environment and society by integrating CSR practices into their main strategic business plan than through isolated CSR projects (Eweje, & Bathurst 2017). Recently, more companies are of the view that sustainability and environmental friendliness are strategic necessities; and a modification of top management group to mirror this particular strategic direction is an imperative (Wiengarten, Lo & Lam, 2017). Traditionally, the main driver of company strategic initiatives is the top management. They articulate, formulate and chart the strategic direction of the company (Guadalupe et al. 2014). The composition of this group is an indication of the strategic direction which the company intends pursue and this also has ultimate implication on cooperate performance (Wiengarten et al 2017). Composition of the board of directors (Rekik, 2016) especially CSR manager, are likely to influence corporate engagement strategy and commitment to CSR. Hence, the appointment of chief CSR officer and their inclusion in top management team, a practice that has gained wide acceptability has been signalled as an indication of importance of CSR. A recent longitudinal study done in the US by Wiengarten et al (2017) explored the extent to which the attributes of the Chief CSR Officer (CCO) appointee influence the performance of the company. The study reveals that appointment of a CSR chief executive results in improve performance, especially if the appointee is a female from CSR line function background.

Understanding local community expectations

The main challenge of MNCs is how to secure the trust of and confidence of its stakeholders. While the companies want to be perceived as showing concern, communities are of the view that they are window dressing and there is no honesty of purpose. Conflict between MNCs and their host communities has largely been attributed to lack of understanding and consideration of what constitute contractual relationship between the two parties (Enuoh & Eneh 2015). Many studies on CSR in developing countries are of the view that understanding local community needs and what they expect will assist organizations incorporate their desires in planning their CSR initiative, and integration into corporate business strategic plan. (Ogula, 2012; Dandago, & Arugu., 2014; Conde, & Le, 2017). Whether CSR is voluntary (ILO 2007) or proactively planned in conjunction with stakeholders in view of societal needs, incorporated into mainstream operations whatever ideological position cooperates situations determines their social performance.

Should CSR be voluntary in the case of mineral exploratory industry? Most African countries are saddled with the problem of inadequate regulations and regulatory mechanisms for CSR (Mbrigenda 2011). Voluntariness of CSR as opposed to an act authorized by law is a challenge. Organizations along these lines do not feel the sense of necessity to participate in CSR, a great deal more where they are not constrained by law (Dartey-baah, Amponsah-tawiah, & Agbeibor, 2015: p 83). For South Africa, compliance functions and legislative monitoring is an exclusive responsibility of government agencies like ministry of environmental affairs where companies are required to submit environmental impact assessment for projects and operations whose implementation may constitute any danger to the environment. Ministry of mineral resources empowered by Mineral and Petroleum Resources Development. Act No.28 of 2002 ensures that companies take adequate responsibility for liability emanating from their operation. Communities has no jurisdiction or responsibility for ensuring environmental regulation compliance. But community through their leadership (representative) bring to the notice of companies complains of environmental /social/ concerns which emanate from companies' operations. Civil society: Monitoring role are limited (Samuel & Mqombot 2017). King committee corporate governance, 2002 advocate for best practices: acceptable guideline for sound corporate governance in SA companies addressing environmental, economic and social needs in the CSR initiative (see Samuel & Mqombot 2017). According to Taras 2015 cited in Samuel & Mqombot 2017, no strong institutional platform to enforce

adequate regulation compliance in CSR activities in Kenya. Civil society has taken it upon themselves to campaign against unacceptable poor working conditions.

Efficiency of sound governance and political will power to delivery common group

Governments in some developing countries fail to effectively regulate the operations of MNCs to ensure compliance to both environmental, social and ethical behaviour (Fitzpatrick, Fonseca, & McAllister, 2011). This can be attributed to corruption and politics which weakness institutional capabilities Ogula, 2012). Furthermore, government is fearing loss of income and hence do not want to scare investors (Littlewood, 2015). What is tenable, in the Nigerian case is that government is preoccupied with revenue earnings from crude oil, without visible concern for ecological degradation of the region that sustains the economy of the country (Gonzalez, 2016). Collusion between the government agents and multinational companies undermine citizens' rights. Although, multinationals seem to benefit unduly from this maladministration, these anomalies increased the vulnerability of the companies and its employees to higher risk. The companies are therefore expected, by the community to inherit government-failed responsibilities and are demanded. Repression of traditional organization of citizen engagement, ignoring the voice of marginalised groups leading to formation of militant group's conflict, which have undertaken to chart the course of their communities through sometimes, violent means.

Companies today have an increasingly understanding of the threats that climate change poses to the society, and their operations. Larger issues of sustainability triggered by climate change are becoming an integral component of dialogues with the major stakeholders. At the same time, verifiable corporate and partners' accountability and reporting have proven to be key drivers.

FACTORS RESPONSIBLE FOR CSR PROJECT FAILURE

Ignoring the context: Context defines expectation, characteristics and attitude. CSR initiatives that ignores the local and national context are unlikely to succeed (Ogula, 2012).

Managerial discretion accentuates that corporate managers as moral agents and are obliged to act in a manner that shows relevance of CSR. Many researchers endorse the fact that managerial values are a determinant of a company's level of CSR commitment (Rekik, 2016; Rashid & Ibrahim, 2002; McWilliams & Siegel, 2011). They emphasise that senior manager's personal ethical values, training, profile and persona is reflective in their leadership role in initiating and implementing CSR initiatives. Managerial training is based on resource optimization through operation and corporate governance of financial prudence. Hence, some do not care to understand sociological matters especially when it, in their view, has no direct implication on bottom line performance parameters. For fear of stakeholder reservations to appropriation of companies' resources, managers should seek ways to generate own funds dedicated to CSR projects. Alternatively, they must obtain stakeholders buy in to include CSR expenditure in the strategic planning budget by justifying such from the competitive advantage paradigm.

Communication: one of the most important needs of community where project is located is information about what is happening in their community- the project. To be well informed, they believe, help in cultivating and maintaining a sense of belonging and satisfactory relationship between the project team and the community. It further galvanises the loyalty and commitment of locals to the project success and ultimate utilization. Indeed, lack of transparency and inadequate communication brings about the discount and discontent. The question here is - how should information flow be managed to increase commitment of stakeholders?

Stakeholder/consideration-community consultation on choice, location of project. CSR project sponsors and managers must consult with the host community. Situations where people from outside the community decide what project will be sited must be avoided as this breeds conflict. The people, through community-based institutions must initiate CSR Projects. This will yield high-level satisfaction and minimise agitation.

Businesses rely on their definition of ethical responsibility without giving due consideration to community or societal need. By so doing, they apply their own discretionary decisions that are not guided by any specific legal framework. As noted by Carol (1991), managers should work within a certain scope while exercising their discretionary ethical responsibility.

Lack of transparent project monitoring mechanism:

Corporate who in their CSR initiative, implement each separate project or selected joint initiative without adherence to good practices models of project management- stakeholder management and project integration, are likely to fail. In view of the voluntary approach to project sponsorship and initiation, and self-regulatory nature of CSR, issues of performance standard, quality standard, performance reporting and quality assurance, cannot be compromised. Failure to do so culminates to wish wash attitude, which ultimately is neither in the interest of the benevolent donor nor in the interest of that of receiving party. Carroll (1991) in her study of stakeholder management in CSR recommended that managers should work within defined predetermined scope when executing their discretionary decisions in lieu social responsibility project.

In summary, the study identified the following trend from literature:

- Huge sums of money are budgeted for SR projects; but spent on companies' discretionary predefined development projects without due consultation with the receiving community. This serves them the purpose of securing social licence to operate and make profit (Dandago & Arugu, 2014; Wilson, 2016)
- The projects are initiated by default, as they are deviant from cogent community needs.
- The projects are not orchestrated towards meeting ascertained sustainable long- term development needs of the communities.
- The social structure that empowers traditional leaders to exclusively make demands on behalf of the host communities, in the face of persistence maladministration and corruption engagement, should be re-examined. It is healthier to involve disparate groups within the host communities in decision making at all stages of mining-driven CSR community development projects (Wilson, 2016).
- Some of the initiated projects are not successfully completed, sometimes the infrastructure (hospital, school etc) is ill-equipped and generally dysfunctional (Frynas, 2012)
- The civic space for activism by communities and non-governmental organisations are always in constantly censored, and manipulated to sometimes in an oppressive manner, hence are agitated to react violently in their demand for social justice.
- Inefficiency on the part of statutory regulatory bodies instituted to ensure enforcement of legal responsibilities – to protect the environment in mining areas (Wilson, 2016)
- In many instances, statutory interventions programs are not well designed or implemented, hence they fail to ameliorate suffering and generate conflict, Kenya (Abuya, 2016). Also, statutory interventions put forward to address injustice of the past like the Niger Delta Development Found (NDDF) in Nigeria are not capacitated and empowered to discharge justice equivocally (Gonzalez, 2016)
- The CSR mitigation tools are still to a large extent undermined by corruption, lack of quality governance and incongruences in decision-making.

RECOMMENDATION & CONCLUSION

Historically, the world evolves through learning and reflection from experience, hence, reporting of CSR activities are critical for all corporate across the world, as the experience of one provides a learning platform for others. Corporates should identify long-term sustainable, people oriented projects that will bring about the much needed succour to the deprived people. This paper advocates for projects that will emancipate the people from poverty, improve their quality of live and ensure social security. Compared to developed world economy with more stringent CSR templates, African countries need to establish independent regulatory teams to ensure enforcement of legal responsibilities in mining areas. There should be a national strategy for promoting CSR.

Government need to acquire and deploy capabilities needed to deal with various risks - communal vulnerability, environmental damage, revenue and investment uncertainties associated; and the unpredictability of investment and revenues associated with mineral exploration. The chamber of commerce and industry initiatives in collaboration with registered companies must create a network to promote interaction, sharing of

lessons and experiences, discrimination of information and cultural orientation of business entities toward best practices.

We are of the perception that TNC in Africa are yet to emancipate the CSR citizenship from the philanthropic disposition to consultative stakeholder's involvement statutory_requirement position. Hitherto, rather than inclusive sustainable development through integration of host community, their CSR engagement is mediated through paternalistic ideology. Some corporates are of the view that beggars cannot be choosers, hence, they embark on community development CSR projects without due consultation with stakeholders (mostly host communities) this has resulted to outright rejection and opposition of these initiative resulting to waste of scarce resources including human lives and poor social performance. This mishap negates the efficacy of CSR investments as a means of achieving competitive edge. We recommend that MNCs in the mineral exploration industry in Africa should dedicate resources towards identifying and implementing projects that deliver long-term strategic and sustainable development; these projects will offer a high propensity to uplift the lives of their host communities. They should vehemently uphold environmental friendliness in their operations, also ensure that the environment is rejuvenated rather than contaminated. In addition, dissemination of CSR information on success stories and strategies that worked will help to situate solutions and best practice so that others can learn from experience of others. The government of the day must rise up to the challenge of giving audience to voice of the people, constituting and empowering effective machinery to reengineer the war against societal oppression, and providing enabling participation environment for communities and NGOs in the vanguard for safe environment and poverty alleviation.

REFERENCES

- Abuya, W. O. (2016). Original article: Mining conflicts and corporate social responsibility: Titanium mining in kwale, Kenya. *The Extractive Industries and Society*, 3, 485-493. doi:10.1016/j.exis.2015.12.008
- Kampala, A. (1990), *Management: An Introduction and Perspective*, Enugu: Published by the Department of Management, Faculty of Business Administration, University of Nigeria, Enugu Campus.
- Bhaduri,S.N. & Selarka,E. (2016). *Corporate Governance and Corporate Social Responsibility of Indian Companies*Springer.
- Brown, J.A. & Forster, W.R. (2013). CSR and stakeholder theory: A tale of Adam smith. *Journal of business ethics*, 112(2):301-312.
- Brundtland, G. World commission on environment and development. (1987). our common future (vol. 383).
- Buldybayeva, G. (2014). Both sides of CSR practice: A case from oil and gas industry in Kazakhstan. *Acta polytechnica hungarica*, 11(2).
- Carroll, A.B. (1999). Corporate social responsibility: Evolution of a definitional construct. *Business & society*, 38(3):268-295.
- Carroll, A.B. (1991). The pyramid of corporate social responsibility: Toward the moral management of organizational stakeholders. *Business horizons*, 34(4):39-48.
- Carroll, A.B. (1979). A three-dimensional conceptual model of corporate performance. *Academy of management review*, 4(4):497-505.
- Clark, J. (1939). *Social control of business* McGraw hill. New York, NY.
- Conde, M. & Le Billon, P. (2017). Why do some communities resist mining projects while others do not? *The extractive industries and society*,

- Dandago, K.I. & Arugu, L.O. (2014). Corporate social responsibility and environmental concerns in Nigeria: A critical focus on oil producing communities. *Issues in social and environmental accounting*, 8(2):104-115.
- Dartey-Baah, K., Amponsah-Tawiah, K. & Agbeibor, V. (2015). Corporate social responsibility in Ghana's national development. *Africa today*, 62(2):71-92.
- DesJardins, J. (2006). *An introduction to business ethics* (2nd ed.). New York, NY: McGraw-Hill.
- Dyllick, T. & Hockerts, K. (2002). Beyond the business case for corporate sustainability. *Business strategy and the environment*, 11(2):130-141.
- Ebner, D. & Baumgartner, R.J. (2006). Corporate responsibility research conference. Conference proceedings of the Xth conference held in Y.
- Enuoh, R & Eneh, S (2015). Corporate Social Responsibility in the Niger Delta Region of Nigeria: In Who's Interest? *Journal of Management and Sustainability*; 5(3): 74-84
- European Commission. Directorate-General for Employment (2001). Promoting a European Framework for Corporate Social Responsibility: Green Paper Office for Official Publications of the European Communities.
- Eweje, G. & Bathurst, R. (2017). *CSR, Sustainability, and Leadership* Routledge.
- Fitzpatrick, P., Fonseca, A. & McAllister, M.L. (2011). From the whitehorse mining initiative towards sustainable mining: Lessons learned. *Journal of cleaner production*, 19(4):376-384.
- Friedman, M. (1962). *Capitalism and freedom*. Chicago: University of Chicago Press.
- Fourie, A. & Eloff, T. (2005). The case for collective business action to achieve systems change: Exploring the contributions made by the private sector to the social, economic and political transformation process in South Africa. *The journal of corporate citizenship*, (18):39.
- Frynas, J.G. (2005). The false developmental promise of corporate social responsibility: Evidence from multinational oil companies. *International affairs*, 81(3):581-598.
- Garvey, N. & Newell, P. (2005). Corporate accountability to the poor? assessing the effectiveness of community-based strategies. *Development in practice*, 15(3-4):389-404.
- Gonzalez, A., (2016). Poverty, oil and corruption: the need for a Quad-Sector Development Partnership (QSDP) in Nigeria's Niger Delta. *Development Policy Review*, 34(4), pp.509-538.
- Guadalupe, M., Li, H. & Wulf, J. (2013). Who lives in the C-suite? organizational structure and the division of labor in top management. *Management science*, 60(4):824-844.
- Ite, U.E. (2004). Multinationals and corporate social responsibility in developing countries: A case study of Nigeria. *Corporate social responsibility and environmental management*, 11(1):1-11.
- Jones, T. M. (1995). Instrumental stakeholder theory: A synthesis of ethics and economics. *Academy of Management Review*, 20(2), 404
- Kok, P., et al., 2001. A corporate social responsibility audit within a quality management framework. *Journal of Business Ethics*, 31 (4), 285–297.
- Himley, M. (2013). Regularizing extraction in Andean Peru: Mining and social mobilization in an age of corporate social responsibility. *Antipode*, 45(2):394-416.

- Hopkins, M. (2005). The fortune to be gained by CSR: Part 1. MHCi monthly feature.
- Idemudia, U. (2014a). Corporate social responsibility and development in Africa: Issues and possibilities. *Geography compass*, 8(7):421-435.
- Idemudia, U., (2014b). Oil companies and sustainable community development in the Niger Delta, Nigeria: the issue of reciprocal responsibility and its implications for corporate citizenship theory and practice. *Sustainable Development*, 22(3), pp. 177-187.
- Idemudia, U., (2014c) Corporate-community engagement strategies in the Niger Delta: Some critical reflections'. *The Extractive Industries and Society*, 1(2), pp. 154-162.
- Mbirigenda, Shukrani K. (2011). Corporate Social Responsibility in Tanzania: A Case for Relationship Management? Paper presented at the DelPHE West African Conference.
- Murphy PE (1978) An evolution: corporate social responsiveness. Univ Mich Bus Rev Organization for Economic Co-operation and Development (OECD) (2001) Corporate responsibility: private initiatives and public goals. OECD, Paris.
- Lambertini, L. & Tampieri, A. (2015). Incentives, performance and desirability of socially responsible firms in a cournot oligopoly. *Economic modelling*, 5040-48.
- Le, D. (2016). Environmental and social risks of chinese official development finance in Africa: The case of the lamu port project, kenya. *African review of economics and finance*, 8(1):106-109.
- Littlewood, D. (2015). Corporate social responsibility, mining and sustainable development in Namibia: Critical reflections through a relational lens. *Development southern Africa*, 32(2):240-257.
- Littlewood, D. (2014). 'Cursed'communities? corporate social responsibility (CSR), company towns and the mining industry in namibia. *Journal of business ethics*, 120(1):39-63.
- Ogula, D. (2012). Corporate social responsibility: Case study of community expectations and the administrative systems, Niger delta. The qualitative report, 17(37)
- Payne, D.M. & Raiborn, C.A. (2001). Sustainable development: The ethics support the economics. *Journal of business ethics*, 32(2):157-168.
- Rekik, H.C. (2016). The determinants of the commitment to corporate social responsibility: Case of Tunisia. *Journal of accounting, business & management*, 23(1)
- Roberts, P.W. & Dowling, G.R. (2002). Corporate reputation and sustained superior financial performance. *Strategic management journal*, 23(12):1077-1093.
- Snider, J., Hill, R.P. & Martin, D. (2003). Corporate social responsibility in the 21st century: A view from the world's most successful firms. *Journal of business ethics*, 48(2):175-187.
- Snyder, C. S. (2014). A guide to the project management body of knowledge: PMBOK (®) guide.
- Uche, F.B. (2010) Management of resource Induced Socio-environmental Conflict in Rivers state. PhD Thesis
- United Nations Development Program. *Niger Delta Human Development Report*. (2006). Abuja: UNDP
- Van der Wiele, T., Kok, P., McKenna, R. & Brown, A. (2001). A corporate social responsibility audit within a quality management framework. *Journal of business ethics*, 31(4):285-297.

Visser, W. (2005). Corporate citizenship in South Africa: A review of progress since democracy. *The journal of corporate citizenship*, (18):29.

Von Hahn, R., Berg, F., Blaum, K., Lopez-Urrutia, J.C., Fellenberger, F., Froese, M., Grieser, M., Krantz,

Welford, R. (2005). Corporate social responsibility in Europe, North America and Asia: 2004 survey results. *The Journal of corporate citizenship*, (17):33.

Wiengarten, F., Lo, C.K. & Lam, J.Y. (2017). How does sustainability leadership affect firm performance? The choices associated with appointing a chief officer of corporate social responsibility. *Journal of business ethics*, 140(3):477-493.

Wilson, S.A. (2015). Corporate social responsibility and power relations: Impediments to community development in post-war Sierra Leone diamond and rutile mining areas. *The extractive industries and society*, 2(4):704-713.

Wood, D.J. (1991). Corporate social performance revisited. *Academy of management review*, 16(4):691-718.

World Business Council for Sustainable Development, Executive Committee (2002). The business case for sustainable development: Making a difference towards the earth summit 2002 and beyond. *Corporate environmental strategy*, 9(3):226-235.

Zambon, S. & Del Bello, A. (2005). Towards a stakeholder responsible approach: The constructive role of reporting. Corporate governance: *The international journal of business in society*, 5(2):130-141.

APPLICATION OF ISHIKAWA DIAGRAM FOR ANALYSIS OF EXPERIENTIAL LEARNING PROGRAM IN HIGHER EDUCATION

Eveth Nwobodo-Anyadiegwu, Charles Mbohwa
University of Johannesburg, South Africa

Michael Mutingi
Namibia University of Science and Technology, Namibia

ABSTRACT

As companies push their frontier in response to technological challenges and global competition, the stakes are high for fresh graduates even as the demand for skilled graduates increases. This paper explored the application of Ishikawa diagram methodology in analysis of EL program of Operations Management students to identify factors that renders the program inefficient. The result reveals diverse challenges ranging from unwillingness of the companies to accept students, funding, safety issues, inadequate support, lack of communication and monitoring from university, and more. Hence, we recommend major policy intervention in areas of funding, provision of adequate support, maintenance of active partnerships between departments/universities; and industry, through active advisory board. The findings have implications for corporates, educational institutions and educational policy makers that are encouraged to apply possible solutions.

Keywords: Experiential learning, skills development, employability, vocational courses, Ishikawa, South Africa.

INTRODUCTION

High education in South Africa has been pledged with many problems ranging from funding, social unrest, low throughput, poor skill development, and more the like, to suitability candidacy and readiness for industry intake. Unemployment in South Africa has soured to a 13-year high of 27.1% according to labour force survey conducted in the third quarter of 2016 (Statistics South Africa, 2016). The president, amongst others, in his state of the nation address attributed unemployment high rate to poor skill development. Furthermore, employers, educators, sponsors and other stakeholders in the value chain have high expectations for the graduated student; but to what extent they are been enabled to acquire highly desired skills seems to be no one's responsibility.

The overall objective of experiential training (EL) for students is to ensure that an appropriate level of skill is gained during their study period at the university or college. This is to bridge the gap between principles and theories taught in class and actual practice. As they come face-to-face with the real-life experience in the industry, it affords them the opportunity, to acquire the competence and capabilities required for entrance and guaranteed acceptability in industry, the one of their profession orientation hence the preparation on practice in the actual work environment for the future environment. Furthermore, they would acquire not only the much-needed managerial problem solving critical thinking skills; but also entrepreneurial skills that entails thinking for innovation combined with managerial leadership that deliver informed solutions, innovation, job creation, and productivity (Ghosh, 2014).

Operations management is a vocational course, and thus require immersed work-related-learning which enable students develop and apply skills and competencies needed for performance in real life industry context. This graduate attribute is an imperative for corporate competitiveness and productivity. Practical skills exhibition is the single most important competency that distinguishes a good operations management graduate from the

rest. The ability of such to optimise organisational resources by performing the expected task effectively and efficiently is an important indication of the degree of skills empowerment (professional competence) that one has received. It also shows the extent to which the program specific outcomes have been achieved.

As companies push their frontier in response to technological challenges and global competition, the stakes are high for fresh graduates even as the demand for skilled graduate increases. According to recent labour survey in South Africa, joblessness is on the increase including graduate unemployment (Oluwajodu, Blaauw, Greyling, & Kleynhans 2015; Statistics South Africa 2017). Evidence indicates that graduating students are ineffectually prepared for entry into professional workplace. However, this dilemma has been largely attributed to lack of workplace experience and inadequate soft skills (Pauw, Oosthuizen, & Van der Westhuizen 2008).

Experiential Learning has to be completed and proof of learning experience provided to the department as a requirement for partial fulfilment towards the award of the relevant degree and diploma. In order to acquire the appropriate level of skill, it is essential for the student to be exposed to the application of theoretical knowledge as it is applied in the work environment. Experiential training is a valued and necessary integral part of all engineering programs in universities and most vocational courses all over the world. Experience begets employment and Operations management is a vocational course, and thus require immersed work-related-learning that enables students develop and apply skills and competencies needed for performance in real life industry context. These graduate attributes are necessary for corporate competitiveness and productivity (Clement, & Cord, 2013).

The objective of the study was to:

- Explore the entire value chain of experiential learning.
- Identify factors that undermine the success of the EL scheme for operations management students.
- Prioritise the factors that undermine the efficacy of the learnership in order to identifying the vital few.
- Recommend interventions for improvement.

In order to design mechanism for improving the quality of EL, it is imperative to conceptualise and comprehensively identify factors that significantly affect the success of the program.

In the recent, quality techniques have been gainfully employed for error/problem identification, definition, and analysis for management problem solving purposes. The Ishikawa diagram uses structured visual graphic that illustrate the root causes of a problem and its alternate implication. Hence, it is known as cause and effect or fishbone diagram. Generally, it is a useful tool for business processes improvement; each 'bone' depicts a possible source of error.

Although there have been numerous studies in continuous improvement in higher education, there are few on engineering education. Furthermore, the mismatch between theoretical knowledge and practice has been highlighted as a serious education concern (Teichler, 2007). In addition, there is an ongoing debate as to how to bridge this gap in order to ameliorate graduate unemployment.

KNOWLEDGE BACKGROUNDS

Experiential Learning and EL Placement

In order to address concerns around student development and graduate attrition, there has been interest in promoting university education that is pragmatic, less didactic, participative, more situated, and 'real life' oriented. Work integrated learning (WIL) is a broad terminology that involve a collection of strategies through which students in high education integrate formal learning with work experience. WIL is a scholastic approach that aligns theoretical knowledge and work practices for the mutual advantage of students and workplaces. There has been an increasing emphasis on work- based learning, as it provides a point of difference for graduates that employers value (Council on Higher Education, 2011). WIL has gained application in many disciplines because of the common understanding of its significance in enabling students to integrate theoretical knowledge acquired

through formal study with the practice-based knowledge gained through immersion in a work or professional context. Although, from literature, the terminology used to describe WIL programs and practices varies, examples -work placements, internships, project based learning, cadetships, co-operative education, industry based learning, experiential learning (EL) (CHE 2011). Generally, students are placed or must find placement in industry related to their chosen career or discipline of study. The EL experience is structured such that they are made to reflect on learning, construct their own conceptual understanding, and apply a wide variety of skills learned in the formal education as they assume roles and responsibilities in authentic work context. They also get timely feedback on performance from their mentors who are industry experts. The University recognises EL as an organised, focused, supervised and assessed educational activity necessary for the completion of vocational courses. For the purpose of this study, this set up of learning from work is termed WIL or Experiential Learning (www.usc.edu.au/explore/policies-and.../work-integrated-learning-academic-policy, 2015).

Work placement involves assessing workplaces for suitability, placement of students in companies, liaising with workplace supervisors and mentors, visiting EL students at work. It also involves integrated support mechanism for students which includes safety, occupational health and safety services, and psychological counselling. The WIL administrator also helps maintain compliance to statutory requirements, keep placement records and other important information related for the program (CHE, 2011).

Problems of Experiential Learning in South African High Education

The South African higher education, following the National Plan on Higher Education (NPHE) of 2001 went through series of mergers resulting to various structural models of institutions – comprehensive universities, universities of technology and traditional universities. The objective of this transformation, according to the department of Education (DoE), was to increase access to university education, sustain student growth and create institutions that are superior in the competence of meeting current industry job market demand (Jansen, 2001). However, far from these expectations, this restructuring resulted to a paradigm shift on * as in the case of Technikons vs. comprehensive traditional universities. Unlike Technikons, traditional universities do not appreciate the role of EL in developing career trajectories (CHE, 2011; Keeping WIL” alive in South African higher education, 2016). Concomitantly, the anticipated growth is driven by institutional interest rather than national or industry need; hence undermining the propensity of universities to show visible commitment and active participation in WIL especially in the case of comprehensive and traditional universities (Keeping WIL” alive in South African higher education, 2016). Experience show that through active institutional involvement in EL, the industry is able to make relevant contributions to the continuous improvement of programs, in this manner contemporary industry demand is incorporated into program curriculum and assessment (“Keeping WIL” alive in South African higher education, 2016).

Figure 1: Interdependency of the different stakeholders in the provision of practical learning for students.

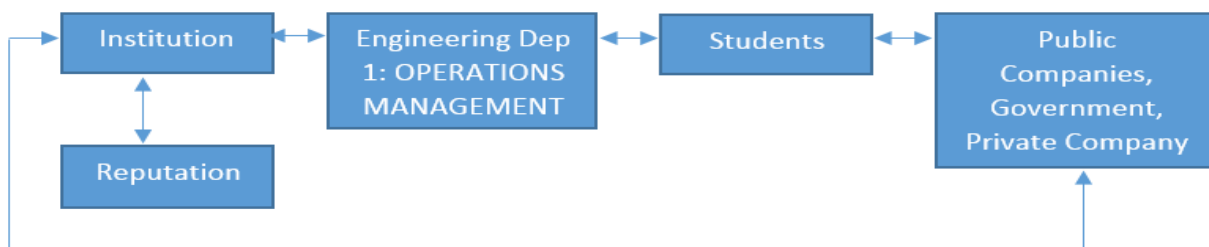

All stakeholders – employers, university, students and academic supervisors, have collective responsibility for knowledge integration through EL, by drawing upon their training as educators, their personal experiences and research. In addition, government need to create an enabling environment for all stakeholders to contribute their quota to increase the success of EL. However, the absence of support, planning and industry placements in the South African scenario has aggravated the quality problems and has led to high student attrition rates and poor employability status for mainstream and graduating students respectively (Confederation of British Industry 2009, SouthAfrica.info. 2009)

Objectives and Benefits of Experiential Learning

Students come to higher education to acquire qualification but most fundamentally, to acquire skills for personal and carrier development which enables them to be gainfully employed and contribute to the society. Though curriculums are structured in ascending order of high learning modules, it also involves an interactive organic process, where knowledge construction, absorption and ultimate application varies from one student to another, but of first principle importance is that the students should be exposed to the expected level of theoretical knowledge as well as practical experience prescribed for the qualification. The efficacy of this holistic package manifest in students' cognitive development, performance and employability. Hence, the purpose of tertiary education is eluded if resources deployment is adequately to bring about this necessary transformation. Some of the implications of poor skill development are unemployment, underemployment, loss of employment, high carrier attrition and generally low productivity and lowered national economic development. At an institutional level, it is an indication of the quality of higher education.

EL mediates the dichotomy between discipline-based theory and vocational knowledge (Nuninger, Conflant, & Châtelet, 2016). The most common benefit of experiential learning reported by all sectors is increased employment opportunities for students by developing employability skills and competencies (Patrick, Peach, Pocknee, Webb, Fletcher & Preto, 2008; CH E, 2011; WIL in STERN disciplines: employer perspectives Australia). EL provides a platform for students to discover what is required; and strategically relevant in the industry, thus help in maturing them for the labour market. It affords the student an opportunity to prepare for, learn from and through experiences applied when executing task in the workplace (Council on Higher Education, 2011). EL also avails the employers an opportunity to influence the curriculum. Furthermore, it reenergises the work place for sustainable cognate skills development to safeguard the future of both academia, industry and economy at large.

Problem Identification Using Ishikawa Tool

Implementation of quality improvement principles can improve efficiency and effectiveness (Koripadu, & Subbaiah 2014; Heizer & Render, 2014; Bose, 2012) of business processes. In high education, this will include student throughput, attrition rates, research output, investor satisfaction, and potential employee's confidence. Furthermore, application of quality management principles has emerged as a means of acquiring competitive edge for higher education (Crosling & Thomas, 2009). Hence, the adoption of quality management strategies has been advocated for sustainability of quality learning in high education.

The cause and effect diagram is one of those tools invented by a Japanese quality guru (Ishikawa). It is used to identify symptoms and causes of process inefficiency (Bose, 2012). Its usefulness is found in driving the root cause analysis of problems from six dimensional attributes. These attributes, as highlighted in literature are people, technology, policies, material, process/method and management, as shown in Figure 2. These attributes may have lower order dimensions which articulate to the major attribute. However, it is worthy to note that categorisation of these sources of root causes could vary depending on how the researcher or decision maker chooses to group them. Some of the models includes 4Ms – Material, Methods, Manpower, and Machinery (Heizer & Render, 2015); Six problem source dimensions - Machines, Mother nature (environment), Materials, Manpower (people), Measurements, and Methods, mostly used for manufacturing industries (Koripadu, & Subbaiah 2014). Developing the Ishikawa diagram involves a brainstorming process through which one is able to make a comprehensive list of both the root causes of a problem and the secondary causes.

Figure 2: Typical Ishikawa diagram

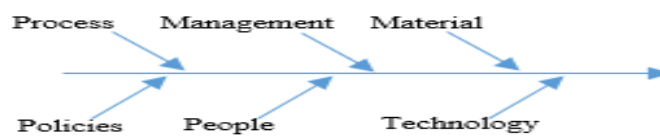

Use of Ishikawa diagram in identification and analysis of the root causes of a problem find application in both manufacturing and service sectors. Identification of root cause of storage tanker accidents (Chan, & Lin, 2006); to uncover sources of quality problems associated with tire re-treading process (Behnam and Alvelos, 2011). Quality improvement at higher education - Use of Six Sigma for improving the pass rate of students at technical institutes (Kaushik, & Khanduja, 2010). However, irrespective of the type or seriousness of the problem, the analysis of these attributes comprehensively and simultaneously using the Ishikawa diagram reveals an inside image and unveils the whys, thus paving the way for an informed solution.

RESEARCH DESIGN AND METHODOLOGY

The sampling population consisted of two groups – 1- all third-year operations management students EL Cohorts of 2016 and 2- industry experts who have provided training and mentorship to the students. The study is in two phases. In phase (1) A focus group consisting of students who have gone through the EL program was formed to identify all possible constraints which negates a positive learning internship, on the bases of their experience. The students included those who are doing their practical learning in 2016. In focus groups, responses were elicited from the students. Also, other stakeholders were interviewed on the challenges experienced with the EL program. Identified problems were clustered according to the stakeholder’s relationship and presented in the Ishikawa diagram. For phase (2), the entire 2016 cohort were sampled using self-administered structured questionnaire. Another questionnaire, semi-structured was used to obtain data from the companies where the students conducted their EL. Also, potential employers from the industry who have been admitting students and those who do not, were included just to get an unbiased view of the problem. They were interviewed to ascertain, from their perspective the problems they have identified with the system.

The purpose of (2) was to generate empirical data, which was analysed by use of Pareto chart and other statistical tools to establish the degree of importance of the enlisted factors. This is to assist with prioritisation of the problems for possible intervention. The research collected data from eighty-seven respondents (87) who completed the questionnaire. Twelve focus groups consist of 60 respondents. Group 2 consisted of nineteen respondents. The target population of students was stratified based on sex and nationality.

The Team was charged with the Following Tasks:

- To uncover the diverse possible challenges of students finding placement in companies which should provide the required training.
- To make a comprehensive list of all factors which lead to poor training/learning experience.
- To reach a consolidated popularly validated consensus on the factors identified.

Figure 3: Process Improvement Diagram for the Practical Learning Program

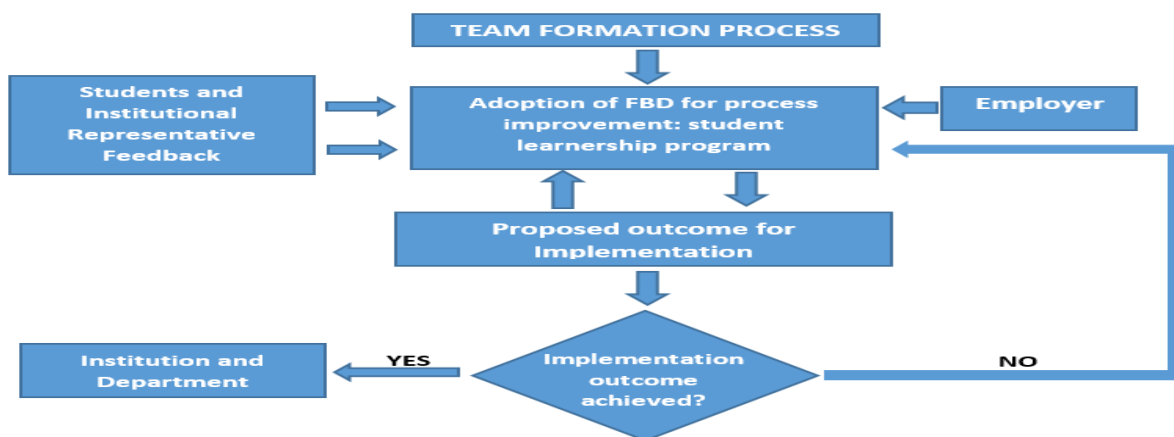

The researchers obtained permission from the University to survey the students for the Study. Those surveyed were students who participated in the EL programme of 2016. Questionnaire was sent to all 140 students. 105 responses were received of which 18 were incomplete and therefore discarded. The quantitative analysis of data collected includes simple counts, percentages and other analysis using SPSS (ver. 23)

FINDINGS, ANALYSIS AND DISCUSSION

Using the Ishikawa diagram above, a close analysis of the EL program revealed the following problems associated with each of the major stakeholders. The items were clustered according to the stakeholder's relationship with the problem as shown in Fig 4 below.

Figure 4: Ishikawa Diagram for Analysis of the Experiential Learning Program

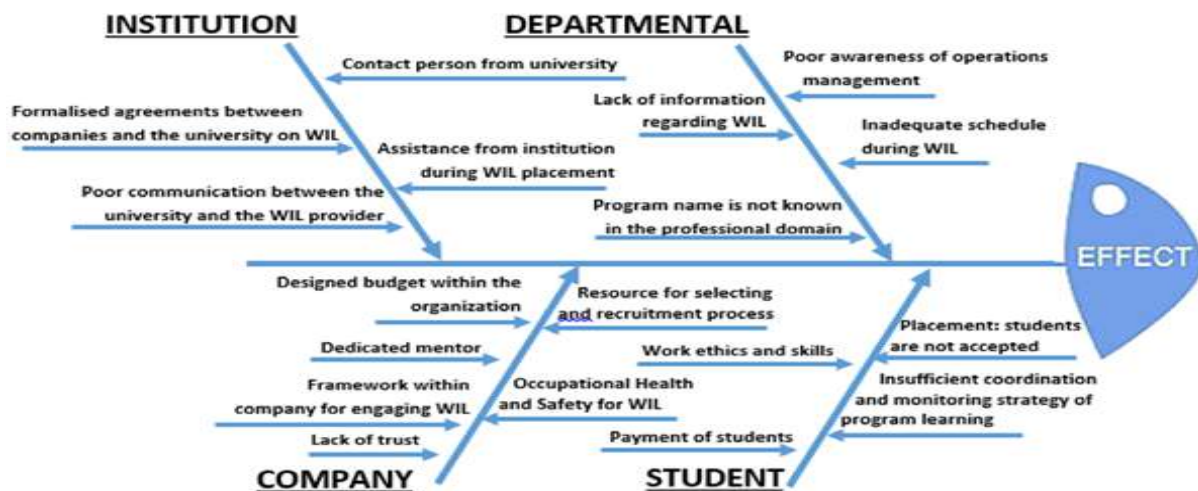

ANALYSIS AND DISCUSSION

On a 5-Point-Likert scale, ranging from 1 (*strongly disagree*) to 5 (*strongly agree*); respondents were asked “To what extent do you agree with the statements [F₁, F₂, to F₁₇] concerning your EL experience. From Table 1, 3.4% of respondents agree that the university facilitated their placement while 84.8% disagree. However, 75.8% of the respondents acknowledge that finding placement was not stress free. Also these issues have a relatively low standard deviation, which shows consistency in the response. Fifty-four percent agree to the fact that their schedule of working and also attending lectures during EL is inadequate. They also prefer proximity to their engagement location especially since they have to juggle work and study at same time.

Table 2: Perception concerning your EL experience

(n=87)	Strongly Disagree/ Disagree	Neutral	Agree/ Strongly Agree
F.1 I had financial constraint during EL because I was not paid	40.20%	14.90%	44.80%
F.2 The university facilitated my placement for EL	84.80%	11.50%	3.40%
F.3 The process of finding EL placement was stress free.	75.80%	18.40%	5.70%
F.4 The coordinator for EL visited me at the company during EL.	79.30%	11.50%	9.20%
F.5 I had insufficient information on who to contact about EL	36.70%	32.20%	31%
F.6 Schedule of working and also attending lectures during EL is inadequate.	26.40%	19.50%	54%
F.7 Limited information about EL opportunities.	16%	29.90%	54%
F.8 The employer has limited information about my field of study.	36.80%	18.40%	44.80%
F.9 Letter from the department which student provides to the company is not enough.	29.90%	21.80%	48.30%
F.10 I had problems with meeting the demand of my ongoing studies during EL	27.60%	34.50%	37.90%
F.11 Occupational health and safety was a concern for my EL.	32.10%	31.00%	36.70%
F.12 The employer has insufficient information on who to contact about EL	35.60%	28.70%	35.60%
F.13 I had no problems adapting to the new work environment.	13.70%	24.10%	62%
F.14 I would like to do my EL at a nearby company.	5.70%	12.60%	81.70%
F.15 At work I spend a lot of time idling because my mentor is busy with other things.	44.80%	25.30%	29.90%
F.16 The experience I gained in EL is relevant to my study.	3.40%	31.00%	65.50%
F.17 EL exposed me to an opportunity for future employment.	9.20%	25.30%	65.50%

Figure 5: Perception concerning your EL experience

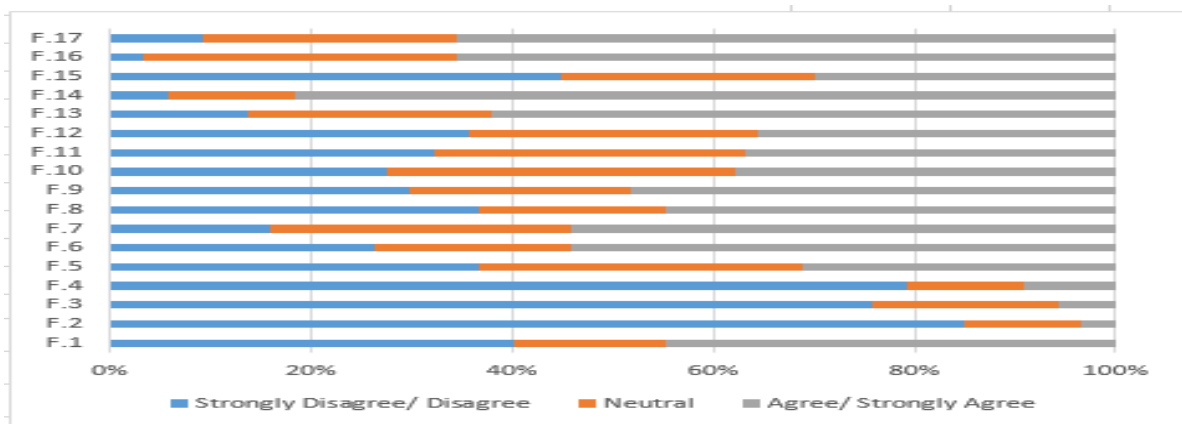

Another question asked “Below is a list of factors that possess a challenge to the quality of the EL Program. Please rate how well each factor is performing in terms of availability on a 5-Point-Likert scale, ranging from 1(not available) to 5(always available) and indicate how important the factor is towards sustainable productivity of the program (Column B) where 1(not important) to 5(extremely important)

Table 3: Challenges of Experiential Learning (EL) Program

Challenges of EL	Availability (n=87)		Importance (n=87)	
	Mean	Std.Dev	Mean	Std. Dev
C.1 University assistance during EL placement	1.92	0.979	4.09	1.168
C.2 University coordination and monitoring	2.07	1.032	4.00	1.023
C.3 Recommendation from university	1.71	0.848	3.99	1.196
C.4 Contact person from university	3.01	1.316	3.98	1.067
C.5 Agreement between university and company for EL engagement	2.18	1.167	3.98	1.161
C.10 Adequate schedule during EL	2.18	1.262	4.15	1.167
C.11 A designated budget within the organisation for EL	2.18	1.105	4.06	0.992
C.16 Funding for students during EL	2.33	1.226	4.14	1.080

The issue of funding for students during the EL was identified as very important. However, the problem of inadequate schedule, funding during EL experience and support from the department and university were reported as paramount concern.

Figure 6: A Pareto chart to identify a prioritisation order for these challenges.

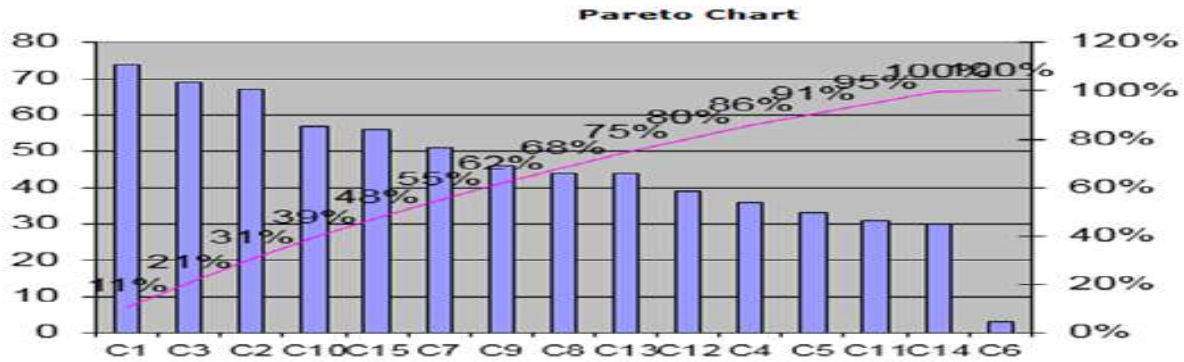
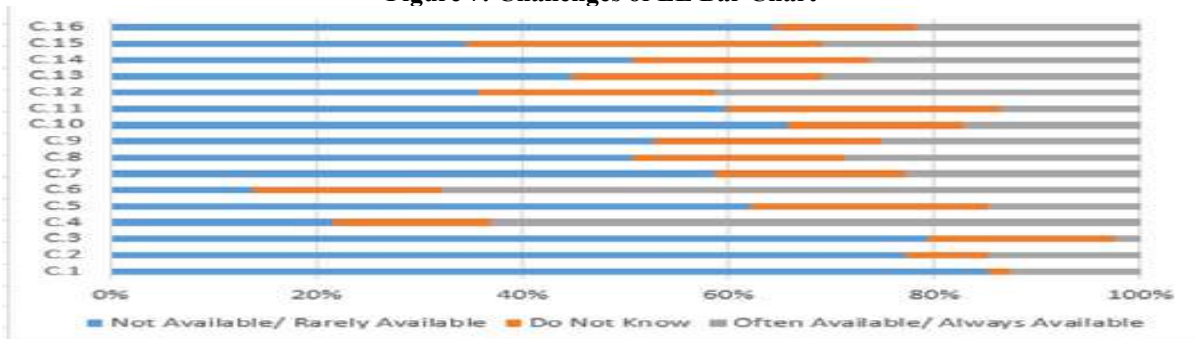

Figure 7: Challenges of EL Bar Chart



The evidence from the data analysis shows that finding placement and having the university support during the process is of critical importance. Also, the schedule of working and studying simultaneously is a challenge. Furthermore, students are uncertain (neutral) about how issues around certain factors that relate to company’s disposition – and the nature of relationship and communication between the company and the university – example C₅, C₁₁, C₁₃ and C₁₅. Hence, the mentors (industry expert) will be more informed about the exact situation. In the same light, the mentors are also not fully aware of the constraints emanating from the student-department relationship. These observations should be taken into consideration in further studies as these limitations affect their response.

CONCLUSION

The current unprecedented dynamics and global competition for talent amongst economies requires high level of skill development, technology adoption and innovation. Sustainability of economic development is a function of skill availability in a continuous incremental propensity. From the concept of total quality management, every stakeholder has a responsibility to contribute meaningfully towards the success of the program. The student, universities, supervisors, and employers have collective responsibility for knowledge integration through EL, by drawing upon their training, research and personal experiences. EL programs should formally state integration of knowledge as an explicit learning objective. Though the university recognises experiential learning as a necessity for sustainable quality assurance for vocational courses, the quality of support is usually inadequate. However, in view of the scarce skills development in South Africa, other stakeholders (industry, employers and government) are yet to fully acknowledge their role (with respect to the Experiential Learning Program) and commit to it.

RECOMMENDATION

- Government should request companies to offer EL as part of their social responsibility. Like the BEE (Black Economic Empowerment) policy – companies must declare how many students they trained. They should also dedicate some of their tax-free returns to funding the trainee program. This will decrease the financial burden on students.
- Academic departments and the university must build relationships with industry partners through advisory boards and other networks; they must show visible commitment towards finding placement for students to improve the quality of EL experience.
- Government sponsored recruitment agencies, in collaboration with departmental coordinators can be dedicated to screen intents according to company requirement before placement. They must understand the employer and universities requirements.
- There should be statutory platforms for higher education- industry-government discussions (Indaba) on making EL programs sustainable and productive.
- The department should provide adequate support including have dedicated people to take responsibility for monitoring and control in the program.
- The government should provide accessible incentives to encourage companies to train students. Owners of small enterprises reported that EL engagement puts a strain on their meager resources.

REFERENCES

- Atkinson, G., Misko, J., & Stanwick, J. (2015). Work integrated learning in STEM disciplines: Employer perspectives.
- Baldry, K. (2016). Graduate unemployment in South Africa: Social inequality reproduced. *Journal of Education and Work*, 29(7), 788-812.
- Behnam, B., & Alvelos, H. (2011). Exploring the Potential of Quality Tools in Tire Retreading Industry: a Case Study. *International Journal of Engineering Science and Technology (IJEST)*, 3(6), 5337- 5345.
- Bose, T. K. (2012). Application of fishbone analysis for evaluating supply chain and business process-A case study on the st james hospital. *International Journal of Managing Value and Supply Chains (IJMVSC)*, 3(2), 17-24.
- Clements, M. D., & Cord, B. A. (2013). Assessment guiding learning: Developing graduate qualities in an experiential learning programme. *Assessment & Evaluation in Higher Education*, 38(1), 114-124.
- Confederation of British Industry (2009). Future fit: preparing graduates for the world of work. London: Confederation of British Industry Higher Education Task Force.
- Council on Higher Education (CHE) (2011). Work-integrated learning: good practice guide. HE Monitor No.12, August 2011, Pretoria
- Crosling, G., Heagney, M., & Thomas, L. (2009). Improving student retention in higher education: Improving teaching and learning. *Australian Universities' Review*, 51(2), 9-18.
- Ghosh, K. (2014). Creativity in business schools: Towards a need based developmental approach. *Global Journal of Flexible Systems Management*, 15(2), 169-178.
- Heizer, J and Render B. (2014). Operations Management, Eleventh Edition. Prentice Hall, Inc
- Jansen, J. (2001). Does the national plan effectively address the critical issues facing higher education. *South African Journal of Higher Education*, 15(3), 5-9.

Kaushik, P., & Khanduja, D. (2010). Utilising six sigma for improving pass percentage of students: A technical institute case study. *Educational Research and Reviews*, 5(9), 471.

“Keeping WIL” alive in South African higher education access on 12/10/2016

Koripadu, M. & Subbaiah K. V. (2014) Problem Solving Management Using Six Sigma Tools & Techniques *International Journal of Scientific & Technology Research* 3(2), 91-93

Nuningger, W., Conflant, B., & Châtelet, J. (2016). Roadmap to ensure the consistency of WIL with the projects of companies and learners: A legitimate and sustainable training offer. *Handbook of research on quality assurance and value management in higher education* (pp. 199-236) IGI Global.

Olson, J. E., & Lalley, K. (2012). Evaluating a short-term, first-year study abroad program for business and engineering undergraduates: Understanding the student learning experience. *Journal of Education for Business*, 87(6), 325-332.

Oluwajodu, F., Blaauw, D., Greyling, L., & Kleynhans, E.P.J. (2015). Graduate unemployment in South Africa: Perspectives from the banking sector. *South African Journal of Human Resource Management/SA Tydskrif vir Menslikehulpbronbestuur*, 13(1) Art. #656, 9 pages. <http://dx.doi.org/10.4102/sajhrm.v13i1.656>

Pali Lehohla (2016) Statistician General Statistics South Africa

Patrick, C., Peach, D., Pocknee, C., Webb, F., Fletcher, M., & Pretto, G. (2008). *The WIL (work integrated learning) report: A national scoping study [final report]* Queensland University of Technology.

Pauw, K., Oosthuizen, M., & Van Der Westhuizen, C. (2008). Graduate unemployment in the face of skills shortages: A labour market Paradox1. *South African Journal of Economics*, 76(1), 45-57.

Simmons, J. M. (2017). *Characteristics of Exemplary Science, Technology, Engineering, and Math (STEM)-Related Experiential Learning Opportunities*,

SouthAfrica.info. (2007). South Africa: economy overview. Retrieved from <http://www.southafrica.info/pls/procs/iac> viewed 25 November 2016

Teichler, U. (2007). Does higher education matter? Lessons from a comparative graduate survey. *European Journal of Education* 42(1):11-34

Winberg, C., Engel-Hills, P., Garraway, J., & Jacobs, C. (2011). Work-integrated learning: Good practice Guide–HE monitor no. 12. () Council on Higher Education (CHE).

www.usc.edu.au/explore/policies-and.../work-integrated-learning-academic-policy 2015 accessed on 13/11/2016).

IMPLEMENTATION OF QUALITY ASSURANCE PRACTICES AND EFFECTIVENESS OF ROAD CONSTRUCTION INDUSTRY: A CASE OF SOUTH AFRICAN LOCAL MUNICIPALITIES

Stephen Nyakala and Thomas Munyai
Tshwane University of Technology, South Africa

Andre Vermeulen and Jan-Harm Pretorius
University of Johannesburg, South Africa

ABSTRACT

The road construction industry in South Africa suffers from major inefficiency, poor strategic planning and poor quality of infrastructure. Data from Small and Medium Enterprise (SME) emerging contractors and local government suggest that projects suffer from 30.1 percent to 39.4 percent inefficiency, lack of strategic planning and poor quality of rural road building. Inadequate planning and management control has been identified as a major source of inefficiency. The objective of this paper is to discuss and analyse the difficulties and inadequacies of quality assurance processes and to use the findings of the research to recommend how the quality assurance processes can be implemented to improve efficiency. This paper sought to develop a system that explains the rural roads construction projects in South Africa. A quantitative research approach was adopted using the survey method in which a questionnaire was administered to 160 randomly selected project/construction managers, architects, quantity surveyors, client/managers and administrators of a South African local government department. Descriptive statistics were analysed using frequencies, percentages, arithmetic mean and standard deviation, whilst Pearson correlation was used to measure the strength of the relationships and confirmatory factor analysis. Based on our findings, we argue that the results of this study can assist SME contractors, rural societies as well as local government authorities in implementing the processes of quality assurance (QA) thus ensuring that rural road building inefficiencies are identified and resolved during the planning phase.

Keywords: Quality Assurance, Processes, South Africa, Construction Projects.

INTRODUCTION

Investment in infrastructure play a significant role in South Africa in dealing with the challenges of economic depriaction (Khumalo, 2013). Particularly, the road infrastructure projects carrying significant for the integrated development of a country (Schachtebeck & Mbuya, 2016). In recent years, increasing emphasis on construction product quality has been exemplified by the introduction of more and more aspects of project management, improvement in quality of road projects. However, the effects of these road projects have been far from satisfactory. Despite the existence of quality standards, ineffective construction quality of rural road infrastructure in construction still remains at a high level. As many researchers reported, the continuous poor quality of infrastructure are mainly due to lack of management commitment and subordinates actions (Fang and Wu, 2013; Martin & Lewis, 2014; Wu et al., 2015). More specifically, road quality has remained a concept held by project managers, owners and supervisors in construction projects. A study conducted by Chen & Luo (2014:64) finds that 1/3 of low-rise building collapses were due to improper construction materials or methods in China. There are many factors that have a potential impact on poor quality and improper construction project control. Chen & Luo (2014:64) further state that

29 per cent of the construction projects accidents in Germany are directly caused by construction quality problems. Construction-site projects accidents due to poor quality assurance processes are significantly worse in South Africa (Statistics South Africa, 2001-2006; CIBD, 2007; Tshivhase & Worku, 2012).

From the perspective of a construction project, the complexity of construction management, uncertainty and inadequate planning and poor quality of construction design within projects settings, quality should be closely controlled and tested throughout each stage of construction (Cheng & Chien-Ho, 2003). It can be argued that quality tools can cope effectively with current construction process complexities (Asim, Zaman & Zarif, 2013). Therefore, many SME contractors continuously attempt to develop and implement quality management practices (Ofori, 2001). Based on extensive literature review and construction experience, quality management is critically necessary for a construction organisation to sustain in current construction market which is highly challenging and competitive and it has to provide the environment in within which related practises, tools and processes can be utilised effectively leading to operational success for an organisation (Khalek, Aziz and Sharabash, 2016).

The Construction product quality can be defined as the degree to which implied or stated needs and internal characteristics are guaranteed during the process of construction (International Organisation for Standardisation, 1994). According to the statistics, it is estimated that it is costing motorists R50 billion in vehicle repairs and injury every year in South Africa due to potholes (Construction Industry Development Board [CIBD], 2010b). A question that arises is what the distinctive circumstances are that affect the adoption of such practices in other companies besides construction organisations and industries.

The research has involved a literature review of implementing Total Quality Management on construction projects, the South African Road Network System, quality assurance/quality control in the construction industry, and construction quality problems, and customer focus (Motwani *et al.*, 2002; Evans & Lindsay, 2014:67). Each of these is discussed in the following sections:

LITERATURE REVIEW

Implementing Total Quality Management on construction projects

In later years, the word 'quality' has evolved to become a significant part of the language in both the manufacturing and service industries as the government departments. Quality has significant and positive effects on construction process, and that both quality and construction process have as well as positive effects on project management performance outcomes (Black & Porter, 1996; Cheng & Luo, 2014). Thiagaragan, Zairi and Dale (2001) also argue that an organisation's performance is also influenced by the extent to which quality is emphasised in the entire construction organisation's systems and processes. Similarly, Khalek et al (2016) revealed construction organisations with advanced quality systems achieve the required level of quality for the product and service which are well planned and organised. Mafini (2015) also suggest that the adoption of the well-acclaimed TQM concept, which is a sub-component of quality, can enable both manufacturing and service organisations to enhance quality, with the aim of improving organisational effectiveness and flexibility.

TQM can be considered as the evolution of another quality tool in order to integrate manufacturing and services (Davis & Heineke, 2005). However, the main challenge for TQM is presented by the special concepts that influence its application in organisations. These concepts seem to be related to both success and failure of quality management systems (Chen & Luo, 2014; Tsironis & Psychogios, 2015). These factors provide the structure for a basic quality assurance system as well as many other components of a competitive quality management system as a means of control procedures for assuring quality in products and processes (Xu & Chang, 2016).

According to Asim *et al.* (2013), implementation of TQM in the construction industry focuses on continuous improvement and also aims to keep the customer satisfied. Pycraft *et al.* (2010:610) defines the term *total quality management* as a philosophy of how to approach the organisation of quality improvement. Hence this

study is devoted to studying quality tools and techniques that could assist construction project-sites and organisations in their pursuit of better quality. Project techniques and tools along with construction quality have been considered as project success parameters (Burke, 2010; Evans and Lindsay, 2014:67). To implement effective quality in any organisation, TQM needs to be applied by all members and during all phases of the project's process (Goetsch & Davis, 2010).

By implementing a TQM approach, construction companies could improve the environment and hence performance (Gunaydin, 1995). It is a methodology that is concentrated on developing and improving quality efficiency in the organisation (Vermeulen, Pretorius, Motjoade & Kruger, 2015). TQM has been applied in the construction industry and in some cases in services and achieves good results, increasing proficiency of processes and improving product quality (International Organisation for Standardisation, 1994). This is mostly true for construction projects, such as road sites and their implementation procedures, due to the fact that total quality has a people and outcome focus (Burke, 2010). This study will concentrate of integrating applications, and approaches to growth and improve process application towards quality assurance in the construction sector.

Olawale and Sun (2015) highlights that construction project control is about assuring that work activities within a project are completed within their respective budgets.

Despite the existence of various studies in this inclusive area, there has been a dearth of studies specific to implementing the construction project assurance process in practice. Studies such Ardit and Gunaydin (1997), Motwani, Mirchandani, Madan and Gunasekaran (2002), Olawale and Sun (2015:624), Jogdand and Deskmukh (2017) do not focus on the construction project control practice in entirety but only on part of the process, such as techniques and tools. For example, the Ardit & Gunaydin (1997) report highlights the need to implement total quality management (TQM) in the construction process and provide scope for improving the organisational performance. In other words, it has been widely argued that application of TQM puts quality at the heart of everything that is done by processing and linking all activities in the organisation (Pycraft, Singh, Phihlela, Slack, Chambers and Johnstone, 2010:610). This view is also supported by Ardit & Gunaydin (1997) which highlights the need to implement TQM in the construction process and provide scope for improving the organisational performance.

Moreover, it is well-documented that TQM approaches involve a wide variety of tools to plan work activities, collect data, analyse results, monitor development and solve problems (Gunaydin, 1995; Goetsch & Davis, 2010). In this respect, Vermeulen *et al.* (2015) and Krajewski, Maholtra and Ritzman (2016) suggest that each author develops and summarises an approach to TQM which reflects their own background, values and experience. In this study extensive literature has been reviewed as well as factors and factor-items affecting quality concerning rural road projects in the South African construction industry among SME contractors in the local governments. On this basis, this study sets out to: (1) discuss and analyse the quality assurance processes of ineffective rural road projects, such as lack of strategic planning and poor quality of construction design by SME contractors in practice in South Africa; and (2) use the findings of the study to recommend how quality assurance processes can be implemented in order to improve efficiency.

The South African Road Network System

The South African road network system is the heartbeat of development, and it performs the basic yet critical function of providing access and mobility for the execution of economic and social activities (Department of Public Transport, Roads & Works, 2003-2006). Writing about South African SMEs contractors, Agumba (2006) states that to enable growth and control costs, they need to have strong management and also utilise the various project management techniques available and also assist government to realise some of its broader socio-economic aims to empower previously disadvantaged individuals. This supports the fact that SMEs are a crucial source of job creation, equity and economic growth. Yet conflicting views about the effect of quality performing assurance processes on road construction projects in rural areas still exist. In line with these developments, the road construction industry has grown significantly and is set to continue growing (Construction Industry Development Board [CIDB], 2007). This, in turn, will assist both national and local government in achieving their objective of promoting the sustainable use of resources for economic growth to benefit the community (Department of Public Works, 1999).

Failure is no stranger to public work projects, but construction site projects seem to have far more than their share of problems (Kerzner, 2009; Tshivhase & Worku, 2012). In South Africa, projects play an important role in terms of job creation, stability of social and economic welfare of the communities (Agumba, 2006; Tshivhase & Worku, 2012). It is further stated in the National Treasury's 2013 Medium-Term Expenditure Framework (MTEF), that R865 billion has been approved and budgeted for public-sector projects, with R296 billion for the energy industry and R262 billion allocated to transport and logistics projects (CIDB, 2010b).

Implementation of quality assurance processes and effectiveness of road construction in rural communities remain ineffective. The government spending on infrastructure projects can be an important strategy to provide economic stimulus (Thwala, 2005). According to the CIDB (2007), South Africa has been achieving substantial expansion in infrastructure investments in both public and private sectors accounting for about 65% to 70% of construction works. Findings which emerged from a study performed by Tshivhase & Worku (2012) indicate increasing infrastructure backlogs as current methods were not adequate for municipalities to deliver service, whilst the demand continues to rise.

Quality assurance/quality control in the construction industry

The construction for quality assurance system (QAS) helps organisations to better organise and synchronise their operations documenting their processes and visibly defining duties and sharing of responsibilities between employees and sections (Gotzamani & Tsiotras, 2001:1326; Xu & Chang, 2014:78; Aliverdi, Naeni & Salehipour, 2013:411). During the past decade there has been a trend amongst organisations regarding the use of preventive rather than corrective methods of quality management as the latter increase costs and decrease efficiency without adding real value to the products (Gotzamani & Tsiotras, 2001:1326). It is widely accepted and well documented that implementing quality assurance standards would bring added value to construction project performance (Vanhoucke, 2012; Aliverdi *et al.*, 2013; Olawale & Sun, 2015).

Researchers in the literature quoted appreciate the significance of prevention mainly due to the fact that the new competitive challenge for organisations is the successful combination of high quality and low price (Gotzamani & Tsiotras, 2001) As mentioned by Kam & Hamid (2013), such effectively implemented quality reference permits the international quality systems to be integrated in a more convenient manner, permitting the systems to be ratified widely. Having specific procedures, clear policies, standards, training, guidelines and systems is positively correlated with project success by directing attention, and motivating and maintaining an efficient quality management system (Arditi & Gunaydin, 1997; Krajewski *et al.*, 2016). Kam & Hamid (2013) further mentions an example of an industry which heavily implemented the ISO standards as the manufacturing industry. In this study comprehensive literature has been reviewed, factors affecting quality concerning road projects in South African construction industry including global environment have been identified and analysed.

Construction quality problems

In the construction industry, quality is generally considered to be delivered for quite some time as they have been implementing total quality management (TQM) practices in the building and construction sector (Asim, Zaman & Zarif, 2013). Khalek, Aziz and Sharabash (2016) mentions that construction quality problems can be divided into defects, common problems and quality accidents. Vanhoucke (2012) and Kam & Hamid (2013) describes quality as involving products, defects, processes, clients, and systems. Quality can be well defined as meeting the customer requirements and providing people in many functions of an organisation a common language for improvement (Oakland, 2003:15). Quality is an important component of construction or facilities in keeping the customers satisfied. Many organisations have arrived at the conclusion that effective QA processes can improve their competitive abilities and provide strategic advantages in the marketplace (Goetsch & Davis, 2010; Krajewski *et al.*, 2016).

Various researchers also highlight that QA processes assure improvements in quality, design of products, services, processes, concurrent engineering, experimental design, design team formation and management (Oakland,

2003). Thus, without a focus on service quality, organisations will face difficulties and protests from both employees and customers, and related monetary and other charges. Some researchers have examined the application of QA processes related to the road construction industry and its positive impact on performance of an organisation.

Customer focus

In general terms, *customer focus* can be defined as the process of acquiring an understanding of customer needs, both existing and future, effective strategies for learning from and listening to customers; and measuring their satisfaction, dissatisfaction, and level of engagement (Evans, and Lindsay, 2014:25; Vermeulen *et al.*, 2015). Oakland (2003) adds that in various organisations empowerment involves that the core organisational strategies are decided centrally, with individual leaders delegated to form a discretionary layer around the core. A review of the literature shows that numerous organisations have identified customer satisfaction as crucial to the successful implementation of a TQM approach, irrespective of the industry to which they belong (Nyakala, 2013; Evans, 2014). In a similar vein, Chen, Ancheeta, Lee and Dahlgard (2016:66) emphasises that customer satisfaction helps improve quality, increases sales and helps optimise the organisation's processes. This implies that the practices of customer involvement components (goal-setting, process specifications, and customisation) can lead to improved performance and competitive edge amongst other competitors. Similarly, Nguyen, Ogunlana and Lan (2004:410) point out that people should be knowledgeable about the project direction, expected project outcome, and particularly their roles. Leadership can influence project success by creating an environment where project teams contribute towards success (Aga, Noorderhaven & Vallejo, 2016). According to this argument, an organisation's success depends increasingly on having opportunities to learn, engagement, teamwork and practicing new skills (Nyakala, 2013; Kruger, Ramphal & Maritz, 2014). This could clearly influence project success. Furthermore, Gotzamani and Tsiotras (2001) underline that the critical success factor lies in the organisations' real commitment to quality improvement and their true target of certification, which finally commands the way and depth to which the standards are implemented.

Research methodology

A literature review on quality assurance processes in the construction industry, SME contractors, and rural road building was undertaken. A quantitative design using the cross-sectional survey approach was used for the empirical portion of the study. The positivist approach, or quantitative research approach, stresses observable facts and eliminates subjective thought (Creswell, 1994). Questionnaire survey was used to find out the current inefficiencies of rural road building. Questionnaires that are completed by respondents themselves are one of the main instruments for obtaining data using a social survey design (Bryman, 2012). The questionnaire was divided into two sections. The first section consisted of respondents' biographical information such as: (1) gender; (2) highest educational level; (3) the position occupied in the business; (4) number of years working in road construction projects, and the second section involved QA processes related to SME-led projects. The survey targeted SME contractors, since they were more likely to construct rural road projects. The sample for the current research consisted of 160 randomly chosen project/construction managers, architects, quantity surveyors, client/managers and administrators of a South African local government department. The sampling frame was a list of Limpopo-based SME contractors and local government officials involved in the rural road building and was accessible from the human resource database of the organisation.

Question responses were measured with a five-point Likert item scale ranging from 1 to 5. A high 73 per cent response rate was achieved primarily due to follow-up telephone calls and mails made to targeted respondents. A computer programme, Windows version 22 of the Statistical Package for Social Science (SPSS), was used to analyse data. Spearman's correlation was used to determine the relationships between variables. The data obtained was analysed using descriptive statistics of frequency and percentage. Factor analysis was adopted to uncover potential variables measuring aspects of the same underlying dimensions (Field, 2013).

The simple random sampling technique was used to select respondents, which ensures that all elements within the population are appropriate for selection as sample elements (Welman, Kruger & Mitchell, 2012). Green's (1991) recommendation that, as a rule of thumb, no less than 50 participants are appropriate for a correlation with

the number increasing with larger numbers of independent variable (IVs) was used as the nominal anchor in determining the sample size.

Survey findings: Quality Assurance Process in Rural Road Construction

The questionnaires were used to gather information on the demographic characteristics of the SME-led projects such as employees' gender, positions and their business plan profile. Analysing and interpretation of gender, the position occupied in the business, highest educational level, number of years running the business, funding of the project, the ownership status of this business and the total annual income of the business will be provided in this section. It must be noted that these questions were precisely formulated in relation to this study in an attempt to produce information about the participants' background. The data generated from the information acquired about the gender distribution are listed in Table 1.1.

Table 1.1: Gender distribution

	Frequency	Percent	Valid Percent	Cumulative Percent
Male	122	76.3	76.3	76.3
Female	38	23.8	23.8	100.0
Total	160	100.0	100.0	

Source: Field work 2016

Table 1.1 shows the gender distribution in the sample which shows that out of 160 respondents, 122 were males (76.3%) and 38 were females (23.8%). This response rate implies that the road construction industry is still dominated by males.

Table 1.2: Highest educational level of respondent in the business

	Frequency	Percent	Valid Percent	Cumulative Percent
Grade 11 or lower (std 9 or lower)				
Grade 12 (N3) only	32	20.0	20.0	20.0
First degree/ Diploma	31	19.4	19.4	39.4
Honours/ B-Tech	55	34.4	34.4	73.8
Masters/M-Tech	37	23.1	23.1	96.9
Total	5	3.1	3.1	100.0
	160	100.0	100.0	

Source: Field work 2016

Table 1.2 presents an overview of the respondent's highest educational level. It shows that 34.4 percent (n=55) of the respondents had a first degree/diploma, followed by respondents with honours/B-tech (n=37; 23.1%) and 20.0 percent (n=32) of the respondents with grade 11 or lower (Std 9 or lower). Finally, 19.4 (n=31) had grade 12 (N3) only while 3.1 percent (n=5) had a Masters/M-tech degree. The section established if employees had explored all the construction industries qualification programmes available to them for further studies in order to understand the design and construction techniques to take into account capability and the substantial knowledge on quality procedures. Thereafter, it was investigated if contractor had a Masters' degree in Construction/ Project Management or Civil Engineering courses. Data generated from this section shows that the majority of respondents in this study do not have a Masters' qualification.

Table 1.3: Position occupied in the business

	Frequency	Percent	Valid Percent	Cumulative Percent
Quantity surveyor	18	11.3	11.3	11.3
Client/Manager	24	15.0	15.0	26.3
Project/construction manager	19	11.9	11.9	38.1
Architect/ QA Engineer	25	15.6	15.6	53.8
Government Official	67	41.9	41.9	95.6
Project Administrator	7	4.4	4.4	100.0
Total	160	100	100	

Source: Field work 2016

Table 1.3 indicates the staff position frequency of the respondents. It shows that 41.9 percent (n=67) of the respondents indicated that they served as government officials, 15.6 percent (n=25) were working as Architect/QA engineers and 15.0 percent (n=24) were working as Client/Manager; 11.9 percent (n=19) reported that they were employed as project/construction managers whilst 11.3 (n=18) indicated that they were working as quantity surveyors in road construction. The smallest number of the respondents (n=7; 4.4%) reported they were working as project administrators.

Table 1.4: Respondents' number of years working in road construction

	Frequency	Percent	Valid Percent	Cumulative Percent
Less than 3 years	5	3.1	3.1	3.1
3- 6 years	42	26.3	26.3	29.4
6-9 years	37	23.1	23.1	52.5
9-12 years	63	39.4	39.4	91.9
12 or more years	13	8.1	8.1	100
Total	160	100.0	100.0	

Source: Field work 2016

The results indicate the respondents participating in the study were well qualified and experienced as shown in table 1.3. Among the responding employees, 39.4 percent (n=63) indicated that they were employed for more than 9-12 years, 26.3 percent (n=42) reported working for between 3-6 years, 23.1 percent (n=37) indicated working in the business between 6-9 years, 8.1 percent (n=13) had worked for more than 12 years whilst 3.1 percent (n=5) had worked for less than 3 years. Participants represented extensive experience in various business units ranging from construction industry structure in South Africa, project management knowledge areas, operation management, information systems, research and development, local governments, small and medium enterprises, local communities and authorities. As part of the survey, it was deemed necessary to know the SMEs which were implementing quality assurance processes.

Table 1.5 four (4) factors extracted (level of skill acquisition process, the planning and control techniques of the project, project construction design, process implementation), twenty-two (22) iterations required. In addition to this, four (4) factors were also extracted (financial management skills, quality standards, organisational structures, as well as involvement of people) are related with quality assurance processes implementation. Pearson's chi-square test proves that SME-led projects did not implement QA processes in the road construction projects. This result indicates that there was no statistical difference between the percentages of the SME-led projects implementing processes of quality assurance in the local municipalities in the road construction projects, which can be termed as a positive moderate correlation at the given levels whereby $p < .000$ for all eight scales measured. Table 1.5 indicates sufficient reliability on the eight (8) coefficients. This means there is a strong relationship between the variables used in SME-led projects related to road construction projects, since the Cronbach is .70 which is advantageous. As a significant positive relationship exists, therefore, there is support for this study question.

Table 1.5: Table KMO and the Bartlett's tests

Factor	KMO measures of sampling adequacy	Bartlett's (Chi-square) test	df	Sig
Level of skill acquisition process	.728	2207.910	105	0.000
The planning and control techniques of the project				
Project construction design				
Process Implementation	.929	9494.842	595	0.000
Financial management skills				
Quality standards				
Organisational structures				
Involvement of people				

Source: Field work, 2016

Percentage of Variance

The factor-loading matrix for implementation of Quality Assurance (QA) processes and effectiveness of road construction is displayed in Table 1.6. All variables loaded above 0.30, in accordance with specifications used as a cut-off basis (Comrey & Lee, 1992). According to Tabachnick & Fidell (2007), the naming of factors is a subjective process and one should always examine the variables that load highly on a factor rather than relying on the name provided by someone else. Seven visible factors were identified.

Table 1.6: Summary evidence of factor-loading matrix

Factor	QA processes implementation and effectiveness of road construction	Factor loading
The planning and control techniques of the project	Every stakeholder becomes involved during the planning process	0.846
	Stakeholder approval of the work package is facilitated	0.937
	All stakeholders receive the project document during the planning phase	0.923
	The community provides input on costs and resources for the project	0.918
	Project manager provides work breakdown detail using computer/software	0.845
	A formal system of record-keeping is used for projects	0.764
Project construction design	Project scope is designed to adopt technology relating to? QA processes for road construction	0.765
	Scope of work or specification supports the reporting of mistakes by the project team	0.852
	Unforeseen and/or different geotechnical conditions are described during the construction design	0.870
	The design of road construction is formally reviewed	0.866
Process implementation	The implementation of QA processes is part of the organisation's vision, present and future systems, and process architecture	0.819
	The practical implementation of the process follows established protocols	0.863
Financial management skills	Payments or processing time for tax exemption are properly completed according to the initial agreement	0.873
	Contractor's establishment costs are evaluated wisely to minimise delays in interim payments	0.883
	Costs are re-estimated and/or incorporated when there are changes on the project	0.859
	All pricing/incentives of services rendered by contractors/consultants are approved and monitored by the fund management	0.711
	Financial difficulties faced by the contractor are identified and managed on the project according to procedures	0.717
Quality standards	Every survey team adheres to a standard set of guidelines on survey implementation	0.865

	QA procedures are applied to describe monitoring of survey implementation in actual settings	0.953
	Evaluation of the QA process is visible throughout the survey implementation	0.953
	Quality control of construction work is conducted by supervising, monitoring, inspections and evaluations	0.875
	Defective work is reworked or improved prior to approval by the supervisor	0.848
Organisational structures	The organisation improves the execution of strategies and plans through formal structure, e.g. meetings	0.894
	The organisational structure is aligned with QA processes	0.932
	Planning, leading and control are facilitated effectively to ensure successful implementation of tasks	0.959
	The quality of the road is defined, established and controlled at both strategic and process/operational levels	0.865
Involvement of people	Customer feedback systems are in place to link all business process-related communication	0.758
	The workforce has been given the schedules for projects	0.822
	The project objectives are shared with all role players	0.903
	There is cooperation between senior management, workforce and community members	0.777

Source: Field work 2016

The various implementation and effectiveness indicators all loaded on one factor, which was labelled level of skill acquisition process. This 1-factor solution, had an eigenvalue of 4.633, and explained 69.679 per cent of the variance. The rotated factor loadings varied between 0.745 and 0.914 for this factor displayed in Table 1.7.

Table 1.7 Exploratory factor analysis

Factor	Factor loading	Eigenvalue	% of Variance explained	% of Cumulative
1-Factor				
Up-to-date training is provided for employees	0.827	4.633	69.679	69.679
Management commitment to providing QA/QC training	0.914			
High level of satisfaction with the training programme	0.895			
Skills development in different roles/areas	0.840			
Management facilitates new employees learning new skills	0.745			

Source: Field work 2016

Eigenvalue

An eigenvalue represents the amount of variance related with the factor. The view is supported by Hair, Black, Babin & Anderson (2014) who state that only factors above 1.0 are retained and other factors with an eigenvalue less than 1 should not be included in the measurement model. In this study, principal axis factoring indicated the presence of one factor with eigenvalue exceeding 1, accounting for 69, 68% of the variance, which is acceptable (Black & Porter, 1996).

Table 1.8: Cronbach’s Alpha Results

Internal Code	Cronbach’s Reliability and Validity Factor and Item Analysis Summary	Number of Items per factors (n-j)	Quality of Implementation – Cronbach’s Alpha	Rating of importance- Cronbach’s Alpha
C1	Level of skill acquisition process	5	0.850	0.879
C2	The planning and control techniques of the project	6	0.872	0.879
C3	Project construction design	4	0.867	0.873
C4	Process implementation	2	0.773	0.774
C5	Financial management skills	5	0.778	0.790
C6	Quality standards	5	0.827	0.849
C7	Organisational structures	4	0.933	0.937
C8	Involvement of people	4	0.681	0.699
	Total number of Items	35		

Source: Field work 2016The result output for the thirty-five (35)

Quality of Implementation Factor-Items and Rating of Importance Factor-Items using SPSS illustrated that the Cronbach’s Alpha value for Quality of Implementation Factor-items are $\alpha = 0.681 \rightarrow \alpha = 0.933$ and for Rating of Importance Factor-Items to be from $\alpha = 0.699 \rightarrow \alpha = 0.937$. The Cronbach’s Alpha of all thirty-five (35) Quality of Implementation Factor-Items and Rating of Importance Factor-Items is greater $\alpha \geq 0.80$ illustrating a good internal consistency (rule of thumb regarding alpha is that alpha should not exceed > 0.80) (Hair *et al.*, 2014) between factors-items in the scale. Quality of Implementation and Rating of Importance Factor-Items measured is according to the latent (or underlying) construct and show an inter-correlation Cronbach’s Alpha measurement of relevancy, reliability and validity.

QA Processes: Kaiser-Meyer-Olkin Test

In this study, the Kaiser-Meyer-Olkin and Bartlett’s test statistic was utilised to measure the sampling adequacy index and appropriateness of Critical Success Aspects analysis and inclusive statistics for each item related to the factor analysis, and determining correlation between items (Field, 2012). The SPSS-Output of Kaiser-Meyer-Olkin (KMO) Measure of Sampling Adequacy and Bartlett’s test of Sphericity statistics is shown in table 1.6. In addition to this, KMO values ranges between 0 and 1 show that the sum of partial correlations is relative to the sum of correlations (Kaiser 1970, 1974). It can further shown that KMO values are inadequate if KMO values are less than < 0.5 and that the variables require corrective action remedial action, either deleting the “offending variables” or including other variables related to the offenders (Kaiser 1970-1974).

Table 1.8 KMO and Bartlett’s Test

KMO and Bartlett’s Test		
Kaiser-Meyer-Olkin of Sampling Adequacy		.728
Bartlett’s Test Sphericity	Approx. Chi-Square	2207.910
	Df	105
	Sig.	.000

Source: Field work 2016

The Kaiser-Meyer-Olkin-Bartlett’s test of Sphericity shows that the KMO value was 0.728 and can be considered as good, demonstrating that factor analysis is accepted for items under review as depicted in Table 1.8. However, no remedial action is required as the KMO value is < 0.50 (Hair *et al.*, 2014). The Bartlett’s test illustrates the strength of the relationship between items and tests if the null hypothesis of the variables in the population correlation matrix is uncorrelated (Field, 2012). The Bartlett test should be substantial (i.e., a significance value of less than < 0.50), illustrating that the items are correlated extremely highly to offer a reasonable basis for factor analysis (Kaiser 1970, 1974). The observed significance level in the Bartlett’s Test *p value* = 0.000 than 0.05

signifying sufficient correlation between items to proceed with EFA (as depicted in Table 1.8) and is small enough to reject the hypothesis. It is concluded that the strength of the relationship between items is strong and to proceed in factor analysis on the data. From the result output, it was determined that the solution(s) cannot be rotated, and the researcher proposes that all the variables be retained as identified and no Critical Aspects will be eliminated or grouped.

CONCLUSION AND RECOMMENDATION FOR FUTURE IMPROVEMENT

There is great potential for quality assurance processes in the construction industry. Rural road projects are considered as important in addressing the challenges in creating job opportunities and help increase economic growth of South Africa. This study aimed at discussing and analysing the processes of quality assurance difficulties, and factors that influence the efficiency of rural road construction projects in South Africa. The local government should increase its efforts in supporting SME contractors implementing QA processes and TQM concepts, which encourage development of SMEs. Firstly, QA processes training programmes need to be arranged by top management for project/construction, project team employees, the government administrators as well as SME contractors/owners. It is imperative to note that most of these QA programmes, particularly in the construction industry are mostly concerned with improving the level of skill acquisition, planning processes, construction design, organisational structures, advanced technology, and involving people. Secondly, it was also noted that the more issues of inefficiencies arise, the less improvement relating to quality of rural road networks and construction design is seen. Overall, the findings show that there is a need for road authorities to ensure that rural road networks are well-constructed and that proper quality management systems are taken into consideration. The issues of lack of strategic planning should be addressed by ensuring that there is commitment and support from top management, adequate planning, QA awareness and improvement activities in place. Advanced QA/QC training programmes should be introduced for SME-led projects, and a wide-range of project management techniques and tools should be applied that are rooted in the perspectives of engineering. Therefore, proper quality management systems and regular maintenance is recommended. When quality of construction design is implemented in these rural road networks for development, gross domestic product (GDP) improves for the nation and growth of the economy in the country is ensured. Based on the factors addressed which negatively reflect on rural roads networks built by SME contractors, future research should focus on investigating the effect of landscape attributes, the quality of road materials used and linked cost of maintenance. The results of this study can assist SME contractors, rural societies as well as local government authorities in implementing the processes of QA properly, thus ensuring that rural road building inefficiencies are identified and resolved during the planning phase. If this is not done, road experts or consultants could train local societies on how to apply this method in order to define, measure, analyse, implement and control inefficiencies occurring on their local roads. More importantly, the assessment method used in this study could assist local government project administrators/authorities to develop a better quality management system for rural road building. Furthermore, the information from the database could be used by local government road construction planners through the compilation of annual Integrated Development Plans (IDPs). Thus, local government project authorities will be enabled to better manage rural road building.

Acknowledgements

We acknowledge the support by the Directorate: Research & Innovation fund of the Tshwane University of Technology (TUT), Office of the Dean: Faculty of Management Sciences at TUT, Faculty of Engineering of Engineering & the Built Environment (Johannesburg of Johannesburg).

REFERENCES

- Aga, D.A., Noorderhaven, N. & Vallejo, B. (2016). Transformational leadership and project success: The mediating role of team-building. *International Journal of Project Management*, 34, pp 806-818.
- Agumba, J.N. (2006). *Evaluating the use of project management techniques in infrastructure by South African small and medium-sized contractors*. Unpublished masters' thesis. Faculty of Engineering and Built Environment, University of Johannesburg.
- Aliverdi, R., Naeni, L.M. & Salehipour, A. (2013). Monitoring project duration and cost in a construction project by applying statistical quality control charts. *International Journal of Project Management* 31 (2013), pp 411-423.
- Arditi, D. & Gunaydin, H.M. 1997. Total quality management in the construction process. *International Journal of Project Management*, 15 (4), pp. 235-243.
- Asim, M., Zaman, S & Zarif, T. 2013. Implementation of Total Quality Management in Construction Industry: A Pakistan Perspective. *Journal of Management and Social Sciences*, 9(1): 24-39.
- Aziz, R.F., Asmaa, A. & Abdel-Hakam. 2016. Exploring delay causes in road construction projects in Egypt. *Alexandria Engineering Journal* (2016) 55, pp 1515-1539.
- Black, A.S. & Porter, L.J. 1996. Identification of the Critical Factors of TQM. *Journal of Decision Sciences*, 27, pp.1.21.
- Bryman, A. 2012. *Social research methods*. 4th Edition. Oxford University Press.
- Burke, R. 2010. *Fundamentals of project management: tools and techniques*. Ringwood: Burke Pub.
- Chen, C., Anhectta, K., Lee, Y. & Dahlggaard, J.J. 2016. A stepwise ISO-based TQM implementation approach using ISO 9001:2015. *Management and Production Engineering Review*, Vol 7 (4), pp.65-75.
- Chen, L. & Luo, H. 2014. *A BIM-based construction quality management model and its application*, *Automation in Construction*, 46, pp. 64-73.
- Cheng, M. & Chien-Ho, K. 2003. *Object-oriented evolutionary fuzzy neural inference system for construction management*, *J. Constr.Eng.Manag.* 129 (4) pp.461-469.
- Comrey, A.L. & Lee, H.B. (1992), *A First Course in Factor Analysis*, 2nd ed., Lawrence Erlbaum, Hillsdale, NJ.
- Construction Industry Development Board (CIDB). 2007. *The building and construction material sector, challenges and opportunities*. Pretoria: Construction Industry Development Board.
- Construction Industry Development Board (CIDB). 2010a. *Targeting for contractor development programme: Background*. Pretoria: Construction Industry Development Board.
- Construction Industry Development Board (CIDB). 2010b. *Construction contact centres*. Retrieved February 12, 2014, from http://www.cidb.co.za/Documents/CCC/Brochure_ccc_limpopo.pdf
- Creswell, J.W. 2003. *Educational Research*, Sage, Thousand Oaks, CA.
- Davis, M.M. & Heineke, J.H. 2005. *Operations management: integrating manufacturing and services* (5th Ed.). New York: McGraw-Hill Irwin.
- Department of Public Works. 1999. *White Paper on "Creating an Enabling Environment for Reconstruction Growth and Development in the Construction Industry"*, Republic of South Africa.

- Department of Public Transport, Road & Works. *Strategic Plan 2003-2006*. Republic of South Africa.
- Evans, J.R. & Lindsay, W.M. 2014. *Managing for Quality and Performance Excellence*. 9th Ed. CENGAGE Learning.
- Fang, D. & Wu, H. 2013. Development of a safety climate interaction (SCI) model for construction project. *Safety Science* 57, 138-149.
- Field, A. 2013. *Discovering statistics using IBM SPSS statistics* 4th ed. Thousand Oaks. CA. SAGE Publication.
- Goetsch, D. L. & Davis, S.B. (2010). *Quality Management for Organizational Excellence. Introduction to Total Quality*. Sixth Edition. Prentice Hall.
- Gotzamani, K. D. & Tsiotras, G. D. 2001. An empirical study of the ISO 9000 standards' contribution towards total quality management. *International Journal of Operations Production Management*, Vol. 21 No. 10, 2001. 1326-1342.
- Green, S.B. 1991. How many subjects does it take to do a regression analysis? *Multivariate Behavioural Research*, 26, pp.499-510.
- Gunaydin, H.M. 1995. *TQM in the construction industry*. MS Thesis, Illinois Institute of Technology, Chicago, IL, 1995.
- Hair, J.F., Black, W.C., Babin, B.J. & Anderson, R.L. 2014. *Multivariate Data Analysis*. 7th Ed. UK: Pearson.
- International Organisation for Standardisation, ISO8402-1994, *Quality Management and Quality Assurance- The Term(s)*, 1994. Jogdand, P. & Deskmukh, S.S. 2017. Development of building quality measurement tool: building construction quality index (BCQI). *International Research Journal of Engineering and Technology (IRJET)*, 4 (1), pp.1020-1026.
- Kaiser, H. 1970. A second generation Little Jiffy. *Psychometrika*, 35, pp. 401-415. (1974).
- Kaiser, H. 1994. An index of factorial simplicity. *Psychometrika*, 39, pp.31-36.
- Kam, K.J. & Hamid, A.H.A. 2014. The true motives behind the adoption of QCLASSIC-CIS 7:2006. As a quality assurance initiative in construction industry. *International Journal of Quality & Reliability*, 32 (6), pp.603-616.
- Kerzner, H. 2009. *Project Management: a systems approach to planning, scheduling, and controlling*. 10th ed. Hoboken, NJ: Wiley.
- Khalek, H.A., Aziz, R.F. & Sharabash, E.A. 2016. Applications and Assessment of Quality Management in Construction Projects. *International Journal of Innovative Research in Engineering & Management (IJIREM)*, 3(5), pp.391-402.
- Khumalo, P. 2013. The Dynamics of Poverty and Poverty alleviation in South Africa. *Gender & Behaviour*. 11, 5643-5652.
- Krajewski, L.J, Ritzman, L.P. & Maholtra, M.K. 2016. *Operations Management Processes and Supply Chains*, 11th ed. UL, Harlow: Pearson Education.
- Kruger, D., Ramphal, R. & Maritz, M. 2014. *Operations Management*. 3rd ed. Cape Town: Oxford University Press Southern Africa.
- Lee, Y.C. 2003. Total manufacturing information systems: a conceptual model of a strategic tool for competitive advantage. *Integrated Manufacturing Systems*, 14(2), 114-122.

- Mafini, C. 2015. Predicting Organisational performance through innovation, quality and inter-organisational systems: A public sector perspective, *The Journal of Applied Business Research*, 31(3), 939-952.
- Martin, H. & Lewis, T.M. 2014. Pinpointing safety leadership factors for safe construction sites in Trinidad and Tobago, *Journal of Construction Engineering Management*. 140(2), 04013046.
- Motwani, J., Mirchandani, D., Madan, M. & Gunasekaran, 2002. Successful implementation of ERP projects: Evidence from two case studies. *International Journal of Production Economics*, 75 pp.83-96.
- Nguyen, L.D., Ogunlana, S.O. & Lan, D. T.X. 2004. A study on project success factors in large construction projects in Vietnam. *Engineering, Construction and Architectural Management*, Vol 11 (6), pp.404-413.
- Nyakala, K.S. 2013. *Evaluating of quality management practices in the Ekurhuleni Public Hospitals, Masters of Technology in Operations Management Dissertation*, University of Johannesburg, South Africa, 2013. Retrieved January 12, 2017 from https://books.google.co.za/books?id=Ng_OAEACAAJ.
- Oakland, J.S. 2003. *Total Quality Management: Text with cases*. Butterworth-Heinemann Publishers.
- Ofori, G. (2001). *Challenges facing the construction industries of Southern Africa. Paper presented at Regional Conference: Developing the Construction Industries of Southern Africa*, Pretoria, South Africa, 23-25 April.
- Olawale, Y. & Sun, M. 2015. Construction project control in the UK: Current practice, existing problems, and recommendations for future improvement. *International Journal of Project Management* 33, pp.623-637.
- Pycraft, M., Singh, H., Phihlela, K., Slack, N., Chambers, S., & Johnston, R. 2010. *Operations Management: Global and Southern African Perspectives*. 2nd. Cape Town: Pearson Education.
- Psomas, E.L., Fotopoulos, C.V. & Kafetzopoulos 2010. *Critical factors for effective implementation of ISO 9001 in SME service companies, Managing Service Quality* (20)5, pp. 440-457.
- Schachtebeck, C. & Mbuya, J.M. 2016. Assessing the potential benefits of road infrastructure development for poverty alleviation: Lessons learnt from developing economies, *Proceedings of the 35th Southern African Transport Conference*, 88-98.
- Statistics South Africa. (2001-2006). *Road Traffic Accident Deaths in South Africa, 2001-2006*. Evidence from death notification. [Online]
- Available at: <http://www.statssa.gov.za> Accessed on: 26 September 2014.
- Tabachnick, B.G. & Fidell, L.S. 2007. *Using multivariate statistics*. 5th ed. Boston.
- Thiagaragan, T., Zairi, M. & Dale, B.G. 2001. A proposed model for TQM implementation based on an empirical study of Malaysian industry. *International Journal of Quality and Reliability Management*, 18(3), 289-306.
- Thwala, W.D 2005. *Employment creation through the provision of low cost housing in South Africa*. Johannesburg: University of Johannesburg.
- Tshivhase, L. & Worku, Z. 2012. Barriers toward the development of emerging contractors in the Limpopo Province. *Journal of US-China Administration*, 9 (3): 268-279.
- Tsironis, L.K. & Psychogios, 2016. A Road towards Lean Six Sigma in service industry: a multi-factor integrated framework. *Business Process Management Journal*, 22 (4), pp.812-834.
- Vanhoucke, M. 2012. Measuring the efficiency of project control using fictitious and empirical project data. *International Journal of Project Management* 30, pp 252- 263.

Vermeulen, A., Pretorius, J.H.C., Motjoade, V. & Kruger, D. 2015. *Developing and Improving Quality Efficiency in the South African Energy Industry*. 2015 Proceedings of PICMET '15: Management of the Technology Age, pp 1985-1992.

Welman, C., Kruger, F. & Mitchell, B. 2012. *Research methodology*. Third edition. Cape Town: Oxford Southern Africa.

Wu, C., Chang, S.H. & Li, N. 2015. Roles of owner's' leadership in construction safety: the case of high-speed railway construction projects in China. *International Journal of Project Management*.107, 185-194.

Xu, Q. & Chang, G.K. 2016. Adaptive quality control and acceptance of pavement material density for intelligent road construction. *Automation in Construction* 62 (2016), pp 78-88.

LOW CARBON AWARENESS AMONG YOUNG ADULTS IN SOUTH AFRICA: A PRELIMINARY STUDY

Adejoke C. Olufemi, Andile Mji and Murembiwa S. Mukhola
Tshwane University of Technology, South Africa

ABSTRACT

For quite a number of years now, there has been a continuous emission of very large amount of carbon dioxide and other greenhouse gases into the atmosphere which has brought about the so called environmental crisis threatening our world today. One important strategy according to one of the United Nations Framework Convention on Climate Change (UNFCC) to address these issues is the development of Low Carbon Society (LCS) by every country. South Africa like other industrialized nations is already in the process of developing and implementing this concept of LCS. As the process continues, it will be very important that the general public especially the young ones are also involved by making sure that they are properly informed about this concept of LCS (Low Carbon Education). The aim of the study was to examine Low Carbon awareness among young adults in Pretoria, South Africa. Being a preliminary study, only one hundred and thirteen male and female young adults of different ages from a particular University residence participated in the study. Data was collected by means of a questionnaire made up of two parts. The first part of the questionnaire will request participants to provide demographic data such as age. The second part comprised 17 - items on a 3 point Likert issues relating to Low Carbon. Data analyses was computed through descriptive statistics using IBM SPSS* Statistics © version 24. The result of the study revealed that majority of the participants generally lacked awareness with regards to Low Carbon issues but exhibited high level of awareness in terms of the other general environmental issues.*

Keywords: Carbon, Climate Change, Green House Gases, Young Adults.

INTRODUCTION

For many years now, the rapid growth in science, technology, agriculture and industry has been responsible for the degradation of our natural environment and has brought about the numerous environmental crisis threatening our world today. One of such problems is air pollution which has led to climate change and global warming. This is caused by human activities primarily by mining and combustion of fossil fuels. As a result of these, there has continually been an emission of large amount of carbon dioxide, methane and other greenhouse gases (GHGs) into the atmosphere. The world's climate is changing every passing day and has continued to have serious effects on human health, plants, animals and the general ecosystem (United Nations Framework Convention on Climate Change [UNFCC], 2006). It has recently been projected by the World Health Organisation that if the situation continues unabated, between the years 2030 and 2050, there is every possibility that additional deaths of 250,000 will occur around the world due to climate change (Hales, Kovats, Lloyd, Campbell-Lendrum, 2014).

There is an urgent need to begin to address these problems now before they get out of hand. One important strategy that was adopted during one of the United Nations Framework Conventions on Climate Change (UNFCC) in addressing these issues is the development of Low Carbon Society (LCS) by every country. The government of every nation in this conventions was advised to reduce the emission of GHGs to minimal levels (UNFCC, 2006). Low carbon according to ENVIRONNET (2016) has been defined as global GHGs emissions pathways which maintain GHGs concentration in the atmosphere at levels recognized not to be 'dangerous anthropogenic interference with the climate system. Phang, Yoke, Siong, Suda, & Fujino, (2015) in their study defined Low Carbon Society as a concept which refers to a minimal output of greenhouse gas (GHGs) emission into the atmosphere.

Low Carbon Society (LCS) also refers to that society where people are mostly collaborating to reduce the amount of carbon dioxide emissions in any forms or in various activities emitting from daily life and from production process of the factory or industry (ENVIRONNET, 2016). It is to be noted that reduction in the emissions of GHGs to a minimal level or concentration in the atmosphere according to IPCC will go a long way to minimize the adverse effect that climate change would have on human and the general ecosystem (UNFCC, 2006). A group of researchers in a recent study averred that....”in a Low Carbon Society (LCS), a different lifestyle will be adopted, the society will make more use of the renewable resources (Recycle, Reuse) and minimize the usage of non-renewable resources (Reduce)....” (Phang, Yoke, Siong, Suda, & Fujino, 2015. P, 21).

South Africa like many other nations of the world has been experiencing serious challenges in terms of air pollution and climate change over the past decades. This is due to the fact that South Africa depends fully on coal for electricity and this produces high levels of GHGs (de Wit, 2005). As a result of this, this country is now in the process of changing from a High Carbon Economy to a Low Carbon Economy as pledged in one of the past UNFCC to reduce the GHGs emissions by 34% in 2020 and 42% in 2025 (Rich, Northrop & Mogelgaard, 2015). One of the steps South Africa is taking to achieve this is by shifting from the use of non-renewable to renewable sources of energy (Sparks, Madhlopa, Keen, Moorlach, Dane, Krog, & Dlamini, 2014). As this process continues, it is very important that the general public are also involved by making sure that they are properly and adequately informed about this idea of LCS. This education or information go a long way in helping every individual whether young or old to begin develop low carbon lifestyles in their various domain, work places, homes, schools and daily lives. This is mostly important for the younger generations because they will later grow up to be the next generation of leaders and decision makers in their various fields. The knowledge they are able to acquire at this early stage of their lives will go a long way in helping them to prevent future environmental problems.

LCS is a new concept that was recently introduced in schools in some countries and quite a number of studies have been reported on the awareness of students or the general public about this concept. For instance China being a highly industrialized and highly polluted country, an awareness about LCS has been raised from time to time over the years throughout the whole country (Gao *et al*, 2017). It was further reported about this country that the general public most especially the younger ones are highly informed about the concept and other environmental issues. This information has come through various means such as school education, scientific reports, newspapers, internet, smartphones, television, radio and other forms of media. Result of this study also revealed about young people in China are more informed and learn faster than the older ones due to the fact that they easily have access to various new or emerging information channels than the older ones (Gao *et al*, 2017). Also in Malaysia there are various activities and programmes the government has been put in place that expose both students and teachers to LCS and other environmental issues (Abdullah, Yoke, Siong, Musa, Safri, & Suda, 2016). In the same Malaysia, a group of researchers have also successfully developed a model to inculcate low carbon awareness among school students and teachers (Phang, Yoke, Siong, Suda, & Fujino, 2015)

Nevertheless in South Africa, little or no studies have been reported. To the best of our knowledge, the present study is one of the first studies that will specifically examine people’s awareness especially young people about LCS in South Africa. The authors of this study have decided to investigate on this matter by first conducting a preliminary study among some few young adults from their own institution. The preliminary study may later or further translate into a larger study.

METHODS

This study employed a quantitative approach by means of questionnaires. The study, being a preliminary study was conducted among few young adults in only one city called Pretoria in Gauteng Province of South Africa.

Participants

Participants for this study were 113 male and female students from a South African University residence. The participants were randomly selected from the seven blocks in the residence

Instruments and Procedures

Data were collected by means of a questionnaire made up of two parts. The first part requested participants to provide their demographic data such as gender and age. The second part comprised 17 items on a 3 point Likert type scale (Agree, Disagree & I don't know) on Low Carbon issues which were adapted from other questionnaires (e.g. Abdullah, Yoke, Siong, Musa, Safri, & Suda, 2016). One hundred and twenty questionnaires were initially administered to students. The completed questionnaires were collected few hours later.

Data Analysis

Of the 120 questionnaires distributed to participants, 113 (94%) copies were returned. In determining students' low carbon awareness, descriptive statistics were employed. All analyses in this study were computed using IBM's SPSS Statistics © version 24.

RESULTS

Biographical Data

Most of the students were males (58.6%) and in their second year (51.4%) of study. A more detailed biographical data of the respondents is outlined in Table 1.

Table 1: Biographical data of students (N = 113)

	n	%
Gender		
Male	65	58.6
Female	46	41.4
No response	2	
Age in years		
17-20	47	44.3
21-23	51	48.1
24 and above	8	7.5
No response	7	
Academic level		
1st Year	57	51.4
2nd Year	32	28.8
3rd Year	15	13.5
4th Year	3	2.7
5th Year	3	2.7
Postgraduate	1	0.9
No response	2	

Findings about students' low carbon awareness

To determine students' Low Carbon awareness, descriptive statistics were used to perform this task. Using percentages, an analysis of each item was done to determine these and only 10 out of the 17 items are presented as seen in Table 2.

Looking at some of the Items, one can infer from the results that majority of the students do not have an idea of what LCS is about. For instance, 23.9% and 47.8% of students responded they do not know about the concept of respectively. Also some (38.1%) of the students reported incorrectly by agreeing to the statement 'Low Carbon Society is a strategy that aims at increasing the amount of greenhouse gases into the atmosphere' while majority (46.0%) of the students responded that they do not even know. In addition to that, majority (64.6%) of the students responded that they do not know that South Africa is in the process of changing to a Low Carbon Society. Similarly, the largest percentage (70.8% of the students are not aware of the fact that South Africa is ranked among the world's top 12 largest carbon dioxide (CO₂) emitters. Also majority (41.6%) of them would prefer that South Africa should continue to depend on fossil fuels (coal) in generating electricity rather than changing to renewable resources.

Looking at items that talk about the general environmental issues, students responded correctly and majority of them were aware about these issues. For example majority of the students (65.5%) agreed that 'Some plants and animals species have gone into extinction as a result of the extreme heat or hot weather we experience these days. Similarly, majority (46.0%) disagreed that South Africa depends on oil and gas for electricity generation. With regards to items that has to do with lifestyle, one can understand from the table that majority (80.5%) of the students disagreed that lights and other electronic devices should be turned off when they are not in use. On the other hand most (62.8%) of the students would prefer to choose to use energy efficient appliances It is better to choose to use energy efficient appliances.

Table 2: Percentages of participants' responses with regards to Low Carbon awareness

		Agree (%)	Disagree (%)	I don't know (%)
1	Low Carbon Society is a concept I am already familiar with	28.3	23.9	47.8
2	Low Carbon Society is a strategy that aims at increasing the amount of greenhouse gases into the atmosphere	38.1	15.9	46.0
3	South Africa is in the process of changing to a Low Carbon Society	23.0	12.4	64.6
4	South Africa is ranked among the world's top 12 largest carbon dioxide (CO ₂) emitters	18.6	10.6	70.8
5	South Africa depends on oil and gas for electricity generation	36.3	46.0	17.7
6	Fossil fuels should be better used in generating electricity than renewable resources	41.6	37.2	21.2
7	Some plants and animals species have gone into extinction as a result of the extreme heat or hot weather we experience these days	65.5	8.8	25.7
8	Lights and other electronic devices should be turned off when they are not in use	11.5	80.5	8.0
9	Industries alone should be blamed for contributing to the emission of carbon into the atmosphere.	29.2	45.1	25.7
10	It is better to choose to use energy efficient appliances.	62.8	23.0	14.2

DISCUSSION

This study sought to explore low carbon awareness among young adults in South Africa using descriptive statistics. The results of the study are discussed and further compared with those reported in literature. The comparison is meant to provide a context as well as a benchmark of sorts against which the results presented in this study may be assessed with regards to what has been reported on other studies around the world.

Looking at the findings of this study, one could infer that majority of the students generally lacked awareness about LCS concept. For example, one could understand from the result that majority of the participants would prefer that South Africa should continue to depend on fossil fuels (coal) in generating electricity rather than changing to renewable resources. This lack of awareness about what is going on in their country has actually affected their attitude towards the environment. For instance, with respect to lifestyle, majority of the participants of this study in one of the items disagreed that lights and other electronic devices should be turned off when they are not in use. They might not have realised that energy is being saved when lights and other appliances are switched off when they are not in use. This result corresponds to and falls within the range of results reported in Malaysia (Aliah & Yoke, 2011). Here it was reported that students' level of awareness and knowledge on the concept of LCS was low.

However studies conducted by other researchers reported opposite findings. These researchers reported in their studies that the level of awareness of their participants about LCS related issues were very high. For example a study conducted in China by Gao *et al* (2017) reported that young participants displayed very high levels of awareness with regards to LCS concept. This was due to the fact that in this country, information about LCS is made available through various avenues such as school education, internet, smart phone, television and a host of other means (Gao *et al*, 2017). Also in Malaysia, a group of researchers in their study reported a high level of awareness among their participants. The reason has been because in Malaysia there are various activities and programmes the government has put in place that expose both students and teachers to LCS and other environmental issues (Abdullah, Yoke, Siong, Musa, Safri, & Suda, 2016)

In terms of the items that talk about the general environmental issues, students responded correctly and majority of them were aware about these issues. This could be due to the fact that they had been exposed to some of these issues right from their high schools and through the media

RECOMMENDATIONS AND CONCLUSION

Based on the result of this study, a number of recommendations are advanced: The result of the study revealed that a larger percentage of students generally exhibited lack of awareness about LCS concept which affected their attitude towards the environment. Therefore there is a need for concentrated effort to be made to begin to educate these young ones about LCS concept and how it will help in mitigating climate change and its impact on human beings, the ecosystem and the environment in general. Also as regards few of them that are already aware about these issues, we suggest there should be a built up on their existing knowledge. This general awareness should not be limited to only the group that participated in this study but for every student at all academic levels whether they are already aware of the idea of LCS or not.

It has been stated earlier that in some other countries like China and Malaysia, the governments have gone so far to put in place so many activities and programmes in order to make sure that awareness and information about LCS reaches every individual especially the young people. It is suggested that as the government of South Africa is in the process of developing and implementing this idea of LCS, efforts should also be made to educate the general public. This could be achieved by trying to imitate what other nations are already doing by making sure that every South African is properly aware and informed about this concept of LCS. This will go a long way in helping people to change their negative lifestyles or behaviour towards the environment. Through this education, people are made to understand that it is not only industries that are responsible for the emission of GHGs into the environment but one way or the other everyone is responsible through their daily activities.

Even though it is very important that the general public is informed, it is suggested that the government focuses more on the younger generation from primary to tertiary institutions. This is because younger people tends to have the ability to learn easily, faster and acquiring information than the older ones. Also they quickly and easily have access to several information channels such as internet, smart phones, school education than the older ones who sometimes are only used to the traditional channels like television and radio (Gao *et al*, 2017). Government and curriculum planners should also consider integrating the concept of LCS into various academic programs at various institutions of learning. This will give every learner an opportunity to learn about LCS concept and equip them with an in-depth understanding and knowledge about issues relating to the concept. In achieving this, trained and competent educators and lecturers in these areas could be employed and also provided with professional development programs.

Furthermore South African government and educational management authorities could try and put in place programmes or activities like other countries to raise awareness and educate people about these issues. These could be through various avenues such as workshops, seminars, campaigns, television, radio and newspapers in communities, schools. The target population should encompass various age groups within all spheres of the society since everyone at one time or the other has to make decisions about the environment, either relating to them or sometimes affecting other people as well (Brennan, 1974). It is also recommended that more research studies are needed to be conducted in this area of LCS as it has earlier been mentioned that limited information is available in literature with regards to this concept.

In conclusion this study has provided preliminary information on Low Carbon awareness of young adults in Pretoria, South Africa. The result has shown that participants generally lacked awareness with regards to Low Carbon issues. This will therefore serve as a baseline benchmark for intervention programmes and provide information needed to promote LSC concept in schools and in the country as a whole. It is to be noted that this environment belongs to all of us, it is therefore very important that we care for it, protect it and preserve it for the future generation.

REFERENCES

- Abdullah, F.A.P.B., Yoke, W.W., Siong, H.C., Musa, A.N., Safri, I. E., & Suda, M. (2016). Low carbon awareness among primary school students through Iskandar Malaysia Ecolife challenge competition. *Man in India Journal*, 96 (1-2), 387-395
- Aliah, P. F., & Yoke, W.W. (2011). Level of awareness on low carbon society concept among secondary school students. In: Education postgraduate research seminar: towards inculcating knowledge & education culture, 14th – 15th December 2011, Faculty of Education, Universiti Teknologi Malaysia.
- Brennan, M. J. (1974). Total education for the total environment. Paper presented at the annual meeting of the American Association for the Advancement of Science in Montreal Québec, December 1964. Reprinted in the *Journal of Environmental Education*, 6 (1), 16 – 19, 1974.
- De Wit, M. P. (2005). Coal Mining and Carbon Constraints: Coaltech 2020. Final Report on task 6.1. de Wit Sustainable Options (Pty) Ltd: Pretoria, South Africa
- ENVIRONNET. (2016). Low Carbon Society. Retrieved 16, June 2016 from <http://www.environnet.in.th/en/archives/1392>
- Gao, J., Xu, G., Ma, W., Zhang, Y., Woodward, A., Vardoulakis, S., Kovats, S., Wilkinson, P., He, T., Lin, H., Liu, T., Gu, S., Wang, J., Li, J., Yang, J., Xiaobo Liu, X., Li, J Wu, H., & Liu, Q. (2017). Perceptions of health co-benefits in relation to greenhouse gas emission reductions: A survey among urban residents in three Chinese Cities. *International Journal of Environmental Research and Public Health*, 14 (298), 1 - 21.
- Hales, S., Kovats, S., Lloyd, S., & Campbell-Lendrum, D. (2014). Quantitative Risk Assessment of the Effects of Climate Change on Selected Causes of Death, 2030s and 2050s. World Health Organization: Geneva, Switzerland
- Phang, F.A., Yoke, W.W., Ho Chin Siong, H.C., Suda, M & Fujino, J. (2015). A successful model to inculcate low carbon awareness among school students and teachers. *Journal of Advanced Research Design*, 12(1) 21 - 34.
- Rich, D., Northrop, E & Mogelgaard, K. (2015). South Africa Pledges to Peak Its Greenhouse Gas Emissions by 2025. World Resources Institute. Retrieved 16, June 2016 from <http://www.wri.org/blog/2015/10/south-africa-pledges-peak-its-greenhouse-gas-emissions-2025>
- Sparks, D., Madhlopa, A., Keen, S., Moorlach, M., Dane, A., Krog, P., & Dlamini, T. (2014). Renewable energy choices and their water requirements in South Africa. *Journal of Energy in South Africa*, 25 (4), 80-92.
- United Nations Framework Convention on Climate Change. [UNFCCC] (2006). United Nations Framework Convention on Climate Change Handbook. Climate Change Secretariat: Bonn, Germany. Retrieved 13, June 2016 from <https://unfccc.int/resource/docs/publications/handbook.pdf>

A FRAMEWORK OF THE FACTORS NECESSARY FOR EFFECTIVE ONLINE MENTORING AS AN E-LEARNING TOOL

**Nadine Oosthuizen and Sandra Perks
Nelson Mandela University, South Africa**

ABSTRACT

With the revolution in technology, online mentoring – mediated through electronic technology – has emerged as an alternative mentoring method. Whilst traditional teaching methods, such as face-to-face lectures, tutorials, and mentoring, remain dominant in the educational sector, universities are investing heavily in learning technologies, to facilitate improvements with respect to the quality of learning. The primary objective of this paper was to develop a framework for effective online mentoring as an e-learning tool. A qualitative study was conducted using desktop research to identify the factors necessary for effective online mentoring. Seven factors were identified as influential in ensuring e-learning through effective online mentoring: the technology infrastructure available; consideration of the matching preference of the mentoring pair; the communication process followed for interaction; the logistics necessary for interaction; the perception of the mentoring pair about online mentoring; the ability of the mentoring pair to develop an online mentoring relationship and the readiness of the mentoring pair to engage in online mentoring.

Keywords: desktop study, e-learning, framework, online mentoring, university.

INTRODUCTION

Mentoring is not a new concept and has received extensive attention in both the academic and general media, including the internet, with an increase in the number of articles published in social sciences and education literature (DiRenzo, Linnchan, Shao & Rosenberg, 2010, p. 292). The one-on-one relationship of conventional mentoring has been described by Shrestha, May, Edirisingha, Burke and Linsey (2009, p.116) as an arrangement where one individual receives advice, mentoring and/or counseling from a second, usually senior, individual. With the revolution in technology, the conventional model of mentoring is changing and online mentoring, mentoring mediated through electronic technology, has emerged as an alternative mentoring method (Leppisaari & Tenhunen, 2009:204). Online mentoring can be mediated using mobile applications where software is created exclusively for use on small, wireless (mobile) computing devices such as smartphones and tablets, or using desktop or laptop computers (Techopedia, 2016). The internet and trends in e-learning have made mentoring practical and cost-effective (Berg, 2009).

Although there are a variety of different fields in which online mentoring is applied, educational institutions lead the way in the use of online mentoring programmes (Smith-Jentsch, Scielzo, Yarborough, & Rosopa, 2008, p.205). In the educational context, time constraints and distance often restrict learners from benefitting from face-to-face mentoring. When mentors are available through an online platform, learners can benefit from their support anywhere and anytime. With increasing availability of internet connections and social collaboration platforms, online mentoring is deemed as beneficial for the overall impact of learning (Thompson, Jeffries & Topping, 2010, p.305). In the online mentoring relationship, the mentor can provide learning, advice, encouragement, and be a role model (Bierema & Merriam, 2002, p.214).

The primary objective of this paper is to develop a framework of the factors necessary for effective online mentoring as an e-learning tool. The remainder of the article will discuss the research methodology followed, after which an overview of online mentoring and e-learning will be provided. A framework of the factors necessary for effective online mentoring as an e-learning tool will be presented and the paper concludes with limitations and recommendations.

RESEARCH GAP

Although mentoring is increasingly viewed as a vehicle for professional development and enhanced service delivery in the educational sector, the opportunity for formal mentoring relationships to develop by chance is limited which lead to efforts to develop an online mentoring community (Thompson, *et al.* 2010, p. 305). The infusion of e-learning in education provides learners with the opportunity to learn as per their needs and convenience, but failures exist (Sun, Tsai, Finger, Chen & Yeh, 2008, p.1183; Majumdar, 2014). The high cost of failure rate of e-learning implementations deserves attention (Sun, *et al.* 2008, p. 1184). Online mentoring is a promising solution to the e-learning constraints (Thompson, *et al.* 2010, p. 313). Even with ready learning material available, learners often need support during an e-course to fully grasp the concepts and their practical applications (Thompson, *et al.* 2010, p. 306). By utilising mentoring through e-mail, instant messaging/chat, video-chat or message boards support, a robust channel of communication can be created which supports the learners' needs (Majumdar, 2014). Leck, Elliott, Bourgeois and Kemp (2014, p. 22) however caution that although access to mentors and mentoring is considerably superior in an online mentoring environment, it is unclear if the quality and effectiveness of online mentoring equals that of conventional mentoring. Online mentoring relationships may be harder to develop than those of conventional face-to-face mentoring given that the majority of the communication lacks non-verbal cues like flow of speech, facial expression, pitch of voice, and body language, thereby making it easy for participants to misinterpret feelings conveyed in communications (Leck & Wood, 2013, p. 104). There is limited empirical research examining the effectiveness and use of online mentoring programmes in e-learning in the educational context (Thompson, *et al.* 2010, p. 306). Accommodating the increasing number of learners, geographical spread and the conflicting schedules of both learners as well as mentors, can impede regular mentoring interactions. This has led to the problem in question to be addressed in this paper: *What are the various factors influencing effective online mentoring as an e-learning tool?*

RESEARCH DESIGN AND METHODOLOGY

This study followed a qualitative research approach as an extensive literature review was conducted. Desk research is the collection of secondary data from internal sources, the internet, libraries, trade associations, government agencies, and published reports (Jesson & Matheson, 2011, p. 10). Already existing information from various sources that other people have gathered through primary research regarding a given problem, are analyzed (Travis, 2016). This is followed by cross referencing and the collation of data. Desk research can serve as a stand-alone research technique or as the initial stage of a study and a precursor to primary research (Jesson & Matheson, 2011, p. 10). In this study it is utilized as a stand-alone research technique.

Internet access has made the process less difficult and has ensured that high-quality data files may be acquired (Bryman & Bell, 2014, p. 268). The viability of comparative studies has increased and new understandings can be obtained from earlier analyses. Re-analyzing data can also lead to further findings and may pose new understandings: a secondary specialist may duplicate the influence of chosen variables that the first researchers had not foreseen or were not considering (Bryman & Bell, 2014, p. 269). The intricacy of the data, as well as the fact that the researcher has no control over the quality of it, can however pose a restriction to the use of secondary data (Bryman & Bell, 2014, p. 271). To overcome this shortcoming, information is collected from a variety of sources and cross-referenced, where possible. This further ensures the accuracy of any findings and assists in contextualising the study within the general body of scientific knowledge (Travis, 2016).

This study has collected, compared and critically reviewed data from academic textbooks, journal articles and internet resources using Google Scholar to enhance the credibility of the data for the development of the

framework of factors necessary for effective online mentoring as an e-learning tool. To ensure the rigour of the analysis of the extant literature, the research question was first developed, after which the secondary data base was developed and evaluated grounded on the purpose of the study and when and by whom the literature was collected (Johnston, 2014, p.620). All literature was read carefully to gain a sense of the information and its context. Factors necessary for effective online mentoring were clustered together according to their contextual similarity and interrelationships and ability to relate to e-learning. The factors were reduced by combining those related to each other. This resulted in seven factors remaining and regarded necessary for effective online mentoring as an e-learning tool. The results of the desktop study were then presented as a framework showing the factors influencing effective online mentoring for e-learning. As the findings of this paper was based on extant global as well as South African literature and sourced mostly from recent journal articles available, it can be regarded as trustworthy. Although the context of this study was on e-learning, the framework can be tested globally in any country and even extend to non-education industries with minor adaptation.

OVERVIEW ON ONLINE MENTORING AND E-LEARNING

Online mentoring facilitates the expansion of face-to-face mentoring as the benefits are additional to those associated with conventional mentoring. It has proved to assist mentees in remote settings in both overcoming professional isolation and in expanding their networks (Kyrgidou & Petridou, 2013, p. 552). Online relationships allow mentees from remote areas, or with problems of mobility, to access mentors with the expertise they seek (provided they have internet access) as it transcends geographical barriers (Leck & Wood, 2013, p. 104). It leads to an equalization of status and reduces potential negative stereotyping and discrimination in mentoring relationships (Leck, *et al.* 2014, p. 4). As online mentoring makes use of leaner communication channels that allow for more direct information transfer, contextual issues are minimized leading to an improvement in the quality of the communication (Rowland, 2012, p. 5). It allows for a written record of interactions to be kept, and it is thus easier to review and reflect on the relationship; it also allows for flexibility with time and space since mentees and mentors do not have to be in the same place at the same time (Rockwell, Leck & Elliot, 2013, p. 2).

Online mentoring is a possible solution to overcome constraints such as limited staff expertise and is viewed as a vehicle for the development and enhancement of service delivery in the educational sector but require the development of online learning modules (Thompson, *et al.* 2010, pp. 305, 313). Whilst traditional teaching methods, such as face-to-face lectures, tutorials, and mentoring, remain dominant in the educational sector, universities are investing heavily in online learning technologies, to facilitate improvements with respect to the quality of learning and online mentoring (Mahdizadeh, Biemans & Mulder, 2008, p. 142). Undergraduate and graduate students, peer groups, staff and students with special needs can all benefit from online mentoring (De Janasz & Godshalk, 2013, p. 763). Although online mentoring has benefits when compared to conventional mentoring, it does present certain challenges.

Factors Influencing Effective Online Mentoring

Online mentoring requires access to the necessary technology, such as the physical devices (specialised software and hardware) and networks required for the online mentoring relationship to be made possible (Rowland, 2012, p. 3). The same is true when working with mobile technology since access to mobile devices, such as smartphones and tablets, is required. Online mentoring programmes must guarantee that participants have regular, easy, and cheap computer and internet access (Headlam-Wells, Gosland & Craig, 2005, p. 456). Effective online mentoring can also be stymied by computer incompatibility issues, such as pop-up blockers, or not having synchronised versions of software available or computer breakdowns (Headlam-Wells, *et al.* 2005, p. 453; Elkin & Elkin, 2008, p. 24). As noted by Kim and Bonk (2006, p. 23), technology has played and continues to play an important role in online education.

Bullock and Ferrier-Kerr (2014, p. 81) confirm that the choice of an appropriate mentor or mentee can create a significant challenge in the online mentoring environment. DiRenzo, *et al.* (2010, p. 302) state that demographic variables like gender, culture and racial issues influence online mentoring relationships, and may pose

a challenge to the matching of parties. Criteria that may be considered when matching participants include gender, age, race, language, availability, needs, interest, geography, individual preferences of mentor and mentee, life experience, and/or temperament (Cox, 2005, p. 406; Wong & Premkumar, 2007, p. 8). Institutions should ensure that the prospective mentoring pairs complete a matching profile questionnaire (Starting an e-mentoring programme, 2016). Being a subject matter expert is considered a very important skill necessary for online learning (Kim & Bonk, 2006, p. 27).

The use of multiple methods of communication contact as a means to increase comfort levels and learning can facilitate the success of the online mentoring relationship (De Janasz & Godshalk, 2013, p. 763). Complementing email-based communication with other methods of communication is recommended and mentoring pairs are advised to incorporate Skype, FaceTime, Google Hangouts and more, as well as telephone conversations, into their relationship. Participants can access and respond to communications in their own time often allowing for more rapid responses by the mentor to the mentee's urgent enquiries (Leck & Wood, 2013, p. 104). The text-based nature of computer-mediated communication facilitates reflection and continuing learning which can assist in resolving possible misunderstandings between the mentoring pair (Rockwell, *et al.* 2013, p. 2). However, the text-based nature of online mentoring makes comprehending communications amid the parties more difficult (Wong & Premkumar, 2007, p. 5). Changeability in writing styles between parties can create a digital segregation (Leck & Wood, 2013, p. 105). Previous experience with a particular communication channel, for example email or online chat, would result in information being sent or received more effectively (DiRenzo, *et al.* 2010, p. 293). It is easier to send a message by mobile technology as it is a more accessible technology and is more convenient than working on a laptop or desktop (Westenberg, 2015). Zhang, Zhao, Zhou and Nunamaker (2004, p. 76) stressed the importance of using a multimedia-based e-learning model that provide a well-structured, synchronised interaction environment.

Logistical issues such the frequency of meetings and the duration of contact time have an influence on the success of a mentoring relationship. Meetings should be scheduled at regular intervals as this provides structure, predictability and support (Allen & Eby, 2010, p. 339). Weekly mentoring tends to produce greater satisfaction than bimonthly mentoring (De Janasz & Godshalk, 2013, p. 747). Long periods of absence online often lead to disinterest or misunderstandings and should be avoided. Sphigelman and Gill (2012, p. 470) found that unsuccessful mentoring pairs experienced communication infrequencies, whereas successful pairs communicated more frequently. In addition, if using Skype, time zone differences may cause synchronisation of meeting times problems (Keengwe & Blankson, 2013, p. 263). While in a face-to-face scenario it may take weeks to agree on a suitable time to meet, an online exchange could take place the same day (Homitz & Berge, 2008, p. 329). Because the interactions do not occur at predetermined or regular time intervals in online mentoring, scheduling is no longer an obstacle (Elkin & Elkin, 2008, p. 17). Online mentoring also allows for informal conversation among individuals and can be broken down into shorter, on-going exchanges, spread over several days or more (Leppisaari & Tenhunen, 2009, p. 191). Zhang, *et al.* (2004, p. 79) warned that there are logistical concerns with e-learning.

Online relationships often begin and continue due to the closeness of values and ideas, rather than demographic similarity and so selection of the correct participants is important. Perceived similarity, with respect to values and attitude between the mentoring pair, impacts on the online relationship positively, while actual demographic similarity between mentee and mentor is not important. The use of online methods for establishing mentoring relationships reduces the importance of observable differences in favour of value likeness (De Janasz & Godshalk, 2013, p. 763). Cox (2005, p. 406), on the other hand, suggests that when alike personalities are paired, less personal development opportunities are available. Furthermore, several authors (DiRenzo, *et al.* 2010, p. 292; Leck & Wood, 2013, p. 105) note that the perception of the mentoring pair of the challenges associated with, and the complexity of, the online mentoring process influences the outcome of the relationship. If individuals have positive attitudes towards diversity, coupled with previous experiences in racially heterogeneous interactions, cross-cultural mentoring is more likely to be successful. Culturally aware and sensitive mentors and mentees are imperative for successful mentoring relationships to develop in the educational context (Kent, Green & Feldman, 2015, p. 118). Berg (2009) noted that in study fields where gender or racial inequality exist, it is easier to match the mentoring pair in an online environment.

An effective online mentoring programme requires clear guidelines around development, time-frame, and training for participants, otherwise the relationship tends to fade rapidly (Rockwell, *et al.* 2013, p. 9). A framework

establishing the purpose of the online mentoring programme should be developed with contribution from all interested parties (Wong & Premkumar, 2007, p. 7). According to Bullock and Ferrier-Kerr (2014, p. 82) it is vital to clarify the intention of any programme and this should include who it is aimed at and what specific changes it is intended to bring about. Trust and reciprocity need to be hallmarks of the online mentoring relationship (Rideout, 2006, p. 46). The online-mentor promotes personal growth by providing emotional support, counselling, acceptance, and guidance (de Janasz & Godshalk, 2013, p. 747). Through discussion forums, information exchange can take place and feelings of isolation done away with. Participants should have access to face-to-face or telephonic interviews in order to combat misunderstandings if the need arise. Zhang, *et al.* (2004, p. 79) confirmed that in e-learning there are issues of trust, confidentiality and individual responsibility that must be discussed between the student and lecturer.

Homitz and Berge, (2008, p. 332) warn that online mentoring relationships require participants to be ready to engage in online mentoring as a definite level of computer literacy and internet knowledge are required. The same applies for knowledge of mobile technology as users must be acquainted with how to use the mobile device as well as how and when to use specific functions (Keengwe & Blankson, 2013, p. 6). Although mobile technology is easier to use some technical restrictions have been suggested, such as small screens with low resolution display, inadequate memory, slow network speeds, and lack of standardization and comparability (Keengwe & Blankson, 2013, p. 16). It is probable that the quality of an individual's online mentoring relationship will be grounded in his or her level of experience with online communication and the internet prior to the start of the programme (DiRenzo, *et al.*, 2010, p. 303). Online learning success is dependent on the student readiness to engage in it (Kim & Bonk, 2006, p. 26).

The effectiveness of the online mentoring process can thus assist with e-learning which refers to the use of technology to deliver information for education and training (Sun, *et al.* 2008, p. 1183; Williams & Kim, 2011:91). Online mentoring seems to be able to provide learners with personal growth benefits by improving their self-development needs, improve their self-confidence, and build their morale. The online medium allows for mentoring to target students without stigmatizing them, reaches out to more students, and enables mentors to better manage the expectations of mentees in this context. It has the potential to motivate students and lecturers, increase student participation and interaction, and provide students with a more active role in their learning, and increased autonomy in the educational process (Mahdizadeh, *et al.* 2008, p. 143; Shrestha, *et al.*, 2009, p. 123; Williams & Kim, 2011:91).

FRAMEWORK FOR EFFECTIVE ONLINE MENTORING AS AN E-LEARNING TOOL

Based on the above literature review, it seems that seven factors are necessary for effective online mentoring as an e-learning tool. The framework of the seven identified factors necessary for effective online mentoring as an e-learning tool is depicted in Figure 1.

Figure 1: Framework for effective online mentoring as an e-learning tool

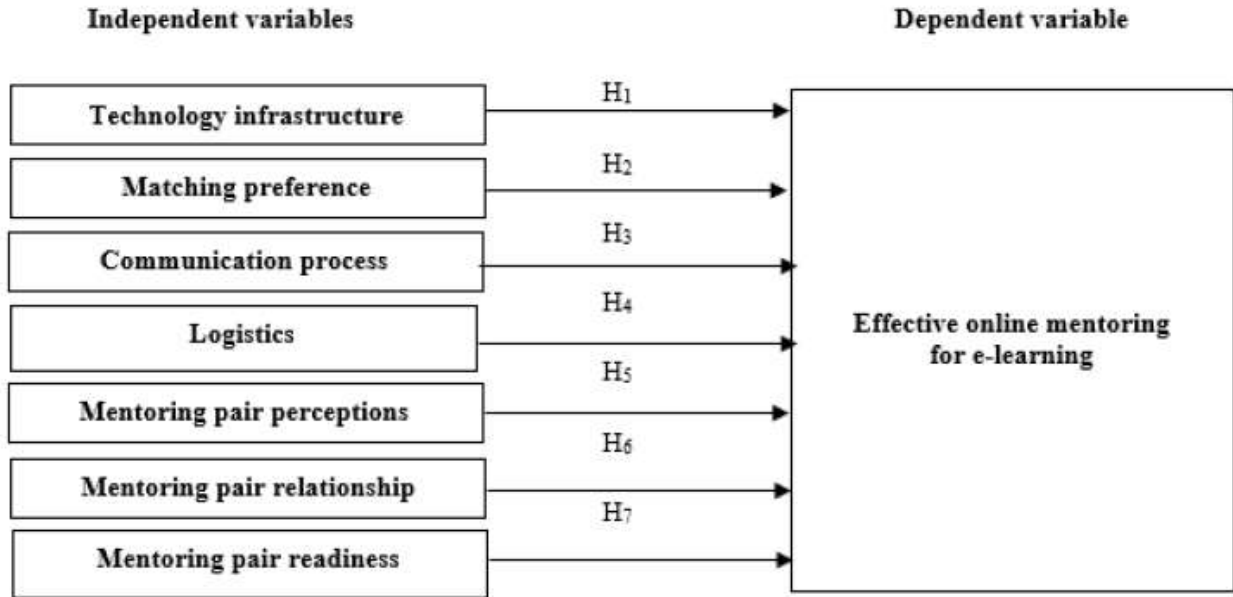

LIMITATIONS, CONCLUSIONS AND RECOMMENDATIONS

It is acknowledged that there may be other factors that may be necessary to ensure effective online mentoring as an e-learning tool. As there is not much information available on online mentoring as an e-learning tool, there was over-reliance on information pertaining to online mentoring which may be generic to any industry. In spite of this, the paper has contributed to the limited existing literature on online mentoring within the e-learning context. Blended learning has become the norm in education today. Given the many opportunities created by e-learning for all potential students, the role of online mentoring to guide and encourage learners should not be underestimated. Learners can obtain social support in addition to educational support. Learners can also acquire new skills, in addition to subject-related knowledge, which can bode them well in the working world. Employees can while being employed study at their own convenience, while having the social support of the online mentor to act as life coach. The importance of online mentoring in the e-learning context should thus not be underestimated. However, it is recommended that the framework of the factors necessary for online mentoring as an e-learning tool be tested in a quantitative study. In this quantitative study the following seven hypotheses can be tested:

H₁: The technology infrastructure available influence the effectiveness of online mentoring as an e-learning tool.

H₂: Consideration of the matching preference of the online mentoring pair influence the effectiveness of online mentoring as an e-learning tool.

H₃: The communication process followed influence the effectiveness of online mentoring as an e-learning tool.

H₄: The logistics necessary to engage in online mentoring influence the effectiveness of online mentoring as an e-learning tool.

H₅: The perception of the mentoring pair about online mentoring influence the effectiveness of online mentoring as an e-learning tool.

H₆: The ease with which a mentoring pair can meet the pre-determined requirements to develop a relationship influence the effectiveness of online mentoring as an e-learning tool.

H₇: The readiness of the mentoring pair to engage in online mentoring influence the effectiveness of online mentoring as an e-learning tool.

Based on the results of the multiple regression analysis in the quantitative study, the factors that are critical to ensure effective online mentoring as an e-learning tool can be established.

REFERENCES

- Allen, T.D. & Eby, L.T. (2010). *The Blackwell Handbook of Mentoring*. New Jersey: John Wiley and Sons.
- Berg, E.J. (2009). Online Mentoring Programmes. *E-Learn Magazine*, September. Available: <http://elearnmag.acm.org/featured.cfm?aid=1620739>. [(Accessed: 29 May 2017)].
- Bierema, L.L. & Merriam, S.B. (2002). Electronic Mentoring: Using Computer Mediated Communication to Enhance the Mentoring Process. *Innovative Higher Education*, 26(3), 211-227.
- Bryman, A. & Bell, E. (2014). *Research methodology*. Cape Town: Oxford University Press.
- Bullock, T. & Ferrier-Kerr, J. (2014). The Potential of E-Coaching and E-Mentoring. *New Zealand Journal of Teachers' Work*, 11(1), 77-92.
- Cox, E. (2005). For Better, For Worse: The Matching Process in Formal Mentoring Schemes. *Mentoring and Tutoring*, 13(3), 403-414.
- De Janasz, S. & Godshalk, V.M. (2013). The Role of E-Mentoring in Protégés Learning and Satisfaction. *Group and Organization Management*, 38(6), 743-774.
- DiRenzo, M.S., Linnehan, F., Shao, P. & Rosenberg, W.L. (2010). A Moderated Mediation Model of E-Mentoring. *Journal of Vocational Behavior*, 76, 292-305.
- Elkin, J. & Elkin, G. (2008). *E-Mentoring: Improving Mentoring to Reduce Expatriate Failure*. Oxford Business and Economics Conference Program. United Kingdom: Oxford.
- Headlam-Wells, J., Gosland, J. & Craig, J. (2005). There's Magic in the Web: E-Mentoring for Women's Career Development. *Career Development International*, 10(6/7), 444-459.
- Homitz, D.H. & Berge, Z.L. (2008). Using E-Mentoring to Sustain Distance Training and Education. *The Learning Organization*, 15(4), 326-335.
- Jesson, J. & Matheson, F. (2011). *Doing Your Literature Review*. Sage: London.
- Johnston, M.P. (2014). Secondary Data Analysis: A Method of which the Time Has Come. *PhD Qualitative and Quantitative Methods in Libraries (QQML)*, 3, 619-626.
- Keengwe, J. & Blankson, L. (2013). *Virtual Mentoring for Teachers: Online Professional Development Practices*. Pennsylvania: IGI Global Publishing.
- Kent, A.M., Green, A.M. & Feldman, P. (2015). The Road Less Travelled - Crossing Gender and Racial Lines in Comprehensive Mentoring. *International Journal of Educational Research*, 72, 116-128.
- Kim, K. & Bonk, C.J. (2006). The Future of Teaching and Learning in Higher Education. *Educause*, 4, 22-30.
- Kyrgidou, L.P. & Petridou, E. (2013). Developing Women Entrepreneurs' Knowledge, Skills and Attitudes through Electronic Mentoring Support. *Journal of Small Business and Enterprise Development*, 20(3), 548-566.

- Leck, J.D. & Wood, P.M. (2013). Forming Trust in E-Mentoring: A Research Agenda. *American Journal of Industrial and Business Management*, 3, 101-109.
- Leck, J.D., Elliott, C., Bourgeois, E. & Kemp, K. (2014). *Mentoring a Diverse Workforce Knowledge Synthesis Grant - Final Report*. Working Paper 2014.01. Canada, University of Ottawa: Telfer School of Management.
- Leppisaari, I. & Tenhunen, M.L. (2009). Searching for E-Mentoring Practices for SME Staff Development. *Journal of Service Business*, 3, 189-207.
- Majumdar, A. (2014). *E-learning*. Available: <http://www.elearninglearning.com/mentoring/?open-article-id=2816785>. [Accessed: 22 January 2017].
- Mahdizadeh, H., Biemans, H. & Mulder, M. (2008). Determining Factors of the Use of E-Learning Environments by University Teachers. *Computers & Education*, 51, 142-154.
- Rideout, S. (2006). Mentoring: Guided by the Light. *PT Magazine*, 14(1), 42-48.
- Rockwell, B. V., Leck, J. D., & Elliott, C. J. (2013). Can E-Mentoring Take the "Gender" out of Mentoring? *Journal of Psychosocial Research on Cyberspace*, 7(2), 2-5.
- Rowland, K.N. (2012). E-mentoring: An Innovative Twist to Traditional Mentoring. *Journal of Technology Management and Innovation*, 7(1), 1-8.
- Shrestha, C.H., May, S., Edirisingha, P., Burke, L. & Linsey, K. (2009). From Face-to-Face to E-Mentoring? *International Journal of Teaching and Learning in Higher Education*, 20(2), 116-124.
- Smith-Jentsch, K.A., Scielzo, S. A., Yarborough, C.S. & Rosopa, P.J. (2008). A Comparison of Face-to-Face and Electronic Peer-Mentoring: Interactions with Mentor Gender. *Journal of Vocational Behavior*, 72, 193-206.
- Sphigelman, C.N & Gill, C.J. (2012). The Characteristics of Unsuccessful E-Mentoring Relationships for Youth with Disabilities. *Qualitative Health Research*, 23(4), 463-475.
- Starting an E-mentoring Program*. (2016). Available: <https://nisd.net/sites/default/files/partnerships/mentorhandout.pdf>. [Accessed: 22 August 2016].
- Sun, P., Tsai, R.J., Finger, G., Chen Y. & Yeh, D. (2008). What Drives Successful E-Learning? *Journal of Computers and Education*, 50(4), 1183-1202.
- Techopedia. (2016). *Mobile App*. Available: <https://www.techopedia.com/definition/2953/mobile-application-mobile-app>. [Accessed: 28 October 2016].
- Thompson, L., Jeffries, M. & Topping, K. (2010). E-Mentoring for E-Learning Development. *Innovations in Education and Teaching International*, 47(3), 305-315.
- Travis, D. (2016). *Desk Research: The What, Why and How*. Available: <http://www.userfocus.co.uk/articles/desk-research-the-what-why-and-how.html>. [Accessed: 17 August 2016].
- Westenberg, J. (2015). *Smartphones Make Communication Easier Not Better*. Available: <http://www.androidauthority.com/smartphones-make-communication-easier-not-better-654878/>. [Accessed: 7 August 2016].
- Williams, S.L. & Kim, J-H. (2011). E-Mentoring in Online Course Projects. *International Journal of Evidence Based Coaching and Mentoring*, 9(2), 80-95.
- Wong, A. & Premkumar, K. (2007). *An Introduction to Mentoring Principles*. Available: <http://studylib.net/doc/12006195/an-introduction-to-mentoring-principles--processes--and-s>. [Accessed: 20 October 2016].

Zhang, D., Zhao, L., Zhou, L. & Nunamaker, J.F. 2004. Can E-Learning Replace Classroom Learning? *Communications of the ACM*, 47(5), 75-79.

FOOD INSECURITY RISKS PERCEPTION AND MANAGEMENT STRATEGIES AMONG HOUSEHOLDS: IMPLICATIONS FOR ZERO HUNGER TARGET IN NIGERIA

Burhan Ozkan and Wasiu Olayinka Fawole
Akdeniz University, Turkey

ABSTRACT

This study is filling the existing gap in study of food insecurity in terms of risk assessment and management strategies. 161 households selected by multistage random sampling technique were investigated in South West Nigeria with Osun and Oyo serving as representative sample for the whole region. The results showed that 87 percent of the households showed various forms of food insecurity risks with food price hikes in 95 percent of the households. The results of logistic analysis showed that three of the explanatory variables showed significant relationships with food insecurity risks in the households at various levels.

Keywords: food insecurity risk, perceptions, household, risk management strategy, Nigeria.

INTRODUCTION

Food security has been variously defined as a multidimensional concept because of its importance in the human survival. The World Food Summit FAO in 1974 defined food security as ‘availability at all times of adequate world food supplies of basic foodstuffs to sustain a steady expansion of food consumption and to offset fluctuations in production and prices’ (FAO, 1974). The initial concern of food security was to bridge the gap between supply in form of food production and the demand triggered by consumption. In 1983, FAO expanded its concept to include securing access by vulnerable people to available supplies thus it was then defined as “ensuring that all people at all times have both physical and economic access to the basic food that they need” (FAO, 1983). Subsequently in 1986, the highly influential World Bank report “Poverty and Hunger” expanded the scope of food security further by taking into consideration the dynamism of food insecurity in terms of chronic and transitory food insecurity again redefined food security as “access of all people at all times to enough food for an active and healthy life (World Bank, 1986). By the mid-1990s, food security was recognized as a significant concern, the definition thus went further to give more concern to the safety and the nutritional values of foods being consumed against the traditional focus on the availability of food in terms of quantity, consequently the concept of food security was redefined to include the nutritional values of the consumed foods being consumed by people. The World Food Summit of 1996 went further to define food security by considering it at different levels such as individual, household, national, regional and global levels. By this categorization, food security is perceived to have been achieved when “all people, at all times, have physical and economic access to sufficient, safe and nutritious food to meet their dietary needs and food preferences for an active and healthy life” (FAO, 1996). Recently in 2001 shortly after the introduction of millennium development goals (MDGs) that gave full recognition to food security as global concerns, food security was redefined in the face of growing food insecurity in the world especially in developing countries as “a situation that exists when all people, at all times, have physical, social and economic access to sufficient, safe and nutritious food that meets their dietary needs and food preferences for an active and healthy life” (FAO, 2002).

MATERIALS AND METHODS

Description of the study area

This study was conducted in south western Nigeria comprising six of the thirty six states of the entire federation and federal capital territory. However, two states of Osun and Oyo were used as the representative samples for all the six states in South Western Nigeria considering their peculiarity in terms of culture, tradition and types of foods being consumed among households in addition to time and resources constraints for the study. According to 2006 population census results, Osun has a population of 3.4 million with 30 local governments while Oyo has 4.5 million people (Osun, 2017) with 33 local governments though the population is more than these now. Osun covers approximately 14,875 square kilometer in land area and lies between latitude 7° 30' N and longitude 4° 30' E and Oyo covers a total of 27,249 square kilometers of land mass and lying between latitudes 6° 45'N – 7° 15'N. The administrative capital city for Osun state is Osogbo and for Oyo is Ibadan, the second largest city in southern Sahara (Oyo, 2017).

Method of data analysis

About 200 questionnaires were administered to the sampled households from which 39 were discarded due to incomplete data and the remaining 161 were analysed (Osun: 76, Oyo: 85). Both descriptive and inferential analysis methods were used to analyse the collected data for this study. For the food security assessments, both qualitative and quantitative food security indicators were used to assess the food security status of the households in the study area as highlighted subsequently and for inferential analysis, logistic regression was used to investigate those factors that affect the food security status of the households in the study area.

Factors influencing the manifestation of food insecurity risks in the households

This paper also investigated those factors that influence the presence or absence of food insecurity risks in the households investigated in the study area. To achieve this logistic regression models which is specified shortly was used.

Specification of the model

$$L_i = \left(\frac{P_i}{1 - P_i} \right) = Z_i \quad (1)$$

Where $i = 1, 2, 3, \dots, n$ ($n = 8$)

From the general model as specified in equation (1) above,

$$Z_i = \beta_0 + \beta_1 X_i + \mu_i \quad (2)$$

P_i = probability that household will show food insecurity risks

$1 - P_i$ = probability that household will not show food insecurity risks

Where $i = 1, 2, 3 \dots 8$ in this case. The equation (5) above can this be rewritten as below,

$$L_i = \left(\frac{P_i}{1 - P_i} \right) = \beta_0 + \beta_1 X_1 + \beta_2 X_2 + \beta_3 X_3 + \beta_4 X_4 + \beta_5 X_5 + \beta_6 X_6 + \beta_7 X_7 + \beta_8 X_8 + \mu_i \quad (3)$$

Where,

Dependent variable = food insecurity risk (presence = 1, otherwise = 0)

X_1 = educational status of household head (number of years spent in school),

X_2 = household size (total number of members in the household eating from the same source),

X_3 = food market distance from households (in kilometres),

X_4 = Unemployed members of the households (number),

X_5 = age of the household head,
 X_6 = cooperative membership status of the household head (member = 1, non-member = 0)
 X_7 = total household monthly income (in naira),
 X_8 = state of location of the household (Osun = 1, Oyo = 0),
 μ_i = error term ((Gujarati and Porter, 2009 and Abbas et al. 2017)

RESULTS AND DISCUSSIONS

Table 1: Food insecurity risks

Risk status	Number of households	Percentage
With risk	141	87.6
Without risk	20	12.4
Total	161	100

Computed from field survey, 2016

Discussions

Perception of food insecurity risk sources

The results as presented on Table 2 show that risk 4 (Exceptional price hikes) was the most prevalence source of food insecurity risks perceived by the household heads in the study area with 95 percent of the households showing it followed by risk 6 (Lack of cash to buy food) being exhibited by 117 households representing 72.2 percent. However, the least perceived food insecurity risk was risk 5 (Low production/yield level) being perceived by 26.1 percent of the households which was largely due to the fact that not all the households in the study engaged in self-production.

Table 2: Types of food insecurity risks perceived in households

Risk type	Number of households	Percentage
Risk 1	59	36.6
Risk 2	53	32.9
Risk 3	100	62.1
Risk 4	153	95.0
Risk 5	42	26.1
Risk 6	117	72.7

Computed from field survey, 2016

Sources of food insecurity risks according to level

The results of the classification of the households according to the level of risks perception as noted in the responses of the households to the questions asked on the food insecurity risks perception are as presented on Table 3. The findings of the study indicate that severe risks perception level constitute the majority of households showing between 4 and 6 sources of food insecurity risks in households investigated followed by both medium (3 risk sources) and low (0 and 2 risk sources) which were equally shared constituting 28 percent each of the entire households investigated in the study.

Table 3: Level of food insecurity risks sources perception

Risk level	Number of households	Percentage
Low (0 – 2)	45	28.0
Medium (3)	45	28.0
Severe (4 – 6)	71	44.0
Total	161	100

Computed from field survey, 2016

Food insecurity risk management strategies

Following the same pattern used in the analysis of risk perception sources as stated earlier, the same method was used in analyzing the management strategies employed by the households to cushion the effects of food insecurity risks in the households. In all, 9 management strategies as listed in the material and methods section of this paper were presented to the household heads and the results according to their responses are as presented on Table 4. The results show that strategy 1 (Consumption of less preferred foods) was the most utilized management strategy and used by 64 percent of the households in the study area followed by strategy 2 (Reduction of the quantity of foods served to the adults in the household) which was being used by 49.7 percent of the households investigated in the study area. However, strategy 6 (Not eating for a whole day) which is seen as most disturbing and drastic strategy was being employed by some households due to prevailing economic situation in the country as of the time of this survey and was being used by 9.3 percent of the households. Though quite a low percentage compared with other strategies, it is still unacceptable because of the effects of this on the dignity and survival of the people. The policy implication of this is that the food insecurity in the study area is critical and endemic.

Table 4: Risks management strategies utilized by households

Management strategies	Number of households	Percentage
Strategy 1	103	64.0
Strategy 2	80	49.7
Strategy 3	73	45.3
Strategy 4	43	26.7
Strategy 5	51	31.7
Strategy 6	15	9.3
Strategy 7	52	32.3
Strategy 8	55	34.2
Strategy 9	35	21.7

Computed from field survey, 2016

Descriptive statistics of the risk perception, management strategies and socioeconomic characteristics

The results of the study according to the descriptive statistics of the variables are as shown on Table 6 subsequently. The results show that the mean of the risk perception and management strategies were 3.25 and 3.15 respectively. Also, the educational status and the age of the household heads were 12.16 and 48.4 respectively. The average household size was 5.2 and average total monthly income of the households in the study area was 49754.28.

Table 6: Descriptive statistics of food insecurity risks and adopted management strategies

Variable	N	Min	Max	Mean	Std. deviation
Risks perceptions	161	0	6	3.25	1.42
Risks management strategies	161	0	9	3.15	2.68
Education status of H/head	161	0	20	12.16	5.59
Household size	161	2	13	5.16	1.97
Age of household head	161	27	82	48.37	11.13
Total monthly income of H/head	161	10000	675000	49754.28	66973.11

Computed from field survey, 2016

Factors determining the presence or absence of food insecurity risks in the households

Following the logistic model as specified in equation (3) in section three of this paper, the result according to the analysis of the data from the survey are as summarized in the equation (5) below;

$$L_i = \left(\frac{P_i}{1-P_i} \right) = -1.198 - 0.021educ + 0.742Size + 1.482Foodmkt + 0.228Unemployed - 0.029Age - 0.035Cooperative - 8e-06Income - 1.504Location \quad (5)$$

Interpretation of logistic regression analysis results

From the results of the analysis of the logistic model as presented on Table 7 subsequently, five of the eight explanatory variables as specified were found to have significant effects on the food insecurity risks manifestation in the households. The statistical significance and relationship with food insecurity risks perception are presented subsequently.

Household size

The results showed that the household size had positive and significant relationship ($p < 0.01$) relationship with food insecurity risks perception at household which is in consistent with a priori expectation. This implies that when the household size increases by 1 member, the odds of household showing food insecurity risk also increases by 2.1. In other word, when the household size increases by 1 member, the probability of households being at the risk of food insecurity also increases by 0.04.

Food market distance from household

The food market distance showed positive and significant ($p < 0.05$) relationship with food insecurity risk perception in the household in line with a priori expectation. This implies that when the distance of the food market from the household increases by 1 kilometer, the odds of food insecurity risk perception would also increase by 4.4. In other word, when the distance of the food market from the household increases by 1 kilometer, the probability of perceiving food insecurity risk would be 0.13.

Unemployed members of the household

The number of unemployed members of the household showed positive and significant ($p < 0.1$) relationship with food insecurity risk perception at the household which concurs with the expectation. The results showed that when the number of unemployed in the household increase by 1, the odds of households manifesting food insecurity would also increase by 1.26. In other word, when the number of unemployed in the household increase by 1, the probability of perceiving food insecurity risks in the household would also increase by 0.01.

Total monthly income of the households (Naira)

The total accruable monthly income to the household showed negative and significant ($p < 0.05$) relationship with food insecurity risk perception in the households. The results as presented on Table 7 show that when the monthly

income of the household increases by 1 naira Nigerian currency, the odds of manifesting food insecurity risk in the household decreased by 1. In other word, when the monthly income of the household increased by 1 naira Nigerian currency, the probability of manifesting food insecurity risk by household decreased by 4.2e-07.

State of location of the household (Osun = 1, Oyo = 1)

The location of the household in the study area that is whether Osun or Oyo as the study was conducted in the two states showed negative and significant ($p < 0.05$) relationship with food insecurity risk perception in the household. The results are as presented on Table 7 subsequently and show that when the household is located in Osun, the perception of food insecurity risk decreased by 0.22 more than when the household is located in Oyo. In other word, when the household is located in Osun, the probability of perceiving food security risk in the household decreased by 0.09 more than when is located in Oyo.

Tests of goodness of fit of the model as specified

The results as presented on Table 7 indicate that the eight explanatory variables as specified in the model had marginal effects on the perception of food insecurity risk at the household going by the p-value which is significant ($p < 0.001$) at 0.01 percent making us to reject the null hypothesis that the explanatory variables do not have marginal effects on the food insecurity risk perception in the household. The pseudo-R² value of 0.2836 suggests that the specified model fits in the data well (McFadden, 1974). Also, we tested for the multicollinearity among the explanatory variables with mean variable inflation factor (VIF) of 1.18 and the least tolerance level of 0.67 confirming the absence of the multicollinearity among the explanatory variables. The Hosmer-Lemeshow chi² (8) also stood at 8.36 which is in conformity with Kuwenyi et al. (2014).

Table 7: Logistic regression analysis results showing the determinants of food insecurity risks sources manifestation in the households

Variables	Coefficient	S.E	Z - stat	p > z	Odds ratio	M.E
Constant	-1.1980	1.9680	-0.10	0.920	-	-
Educational status of household head (years) X ₁	-0.0214	0.0625	-0.34	0.732	0.9788	-0.0011
Household size (number of members) X ₂	0.7417*	0.2427	3.06	0.002	2.0994	0.0388
Food market distance from households (km) X ₃	1.4816**	0.6555	2.26	0.024	4.4001	0.1265
Unemployed members (number) X ₄	0.2282***	0.1167	1.96	0.051	1.2563	0.0119
Age of the household head (years) X ₅	-0.0286	0.0260	-1.10	0.270	0.9718	-0.0015
+Cooperative membership (mem=1, non-mem=0)	-0.0348	0.5639	-0.06	0.951	0.9658	-0.0018
Total household income (Naira) X ₇	-8e-06***	4e-06	-2.03	0.042	0.9999	-4.2e-07
+State of location of household (Osun=1, Oyo=0)	-1.5043**	0.6346	-2.37	0.018	0.2222	-0.0868
Log likelihood	-44.66	Number of observations	161			
LR chi ² (8)	35.35	Mean marginal effects	0.945			
Hosmer-Lemeshow chi ² (8)	8.36	Prob > chi ² (p-value)	0.0000			
Percentage of correct predictions	91.3	Pseudo R ²	0.2836			

Note:

S.E: Standard Error; M.E: Marginal effects

(+) represents dummy variables (0 or 1); **Dependent variable:** Food insecurity risk perception;

***, **, * are statistical significance at 1%, 5%, and 10% levels respectively.

CONCLUSIONS

Based on the findings of this study, it is evident that the persistent of food insecurity risks in the study area is glaring going by the high number of the risk sources and the adopted management strategies in such situation. Majority of the households had shown risk 4 (Exceptional price hikes) and risk 6 (lack of cash to buy food) in that order while majority of the household resorted to strategy 1 (Consumption of less preferred foods) and strategy 2 (Reduction of the quantity of foods served to the adults in the household) also in that order to mitigate the effects of food insecurity risks in the households. The results of the study has also shown that the size of the household, food market distance from the household, number of unemployed members of the family, total income and the location of the household have shown significant relationship at various levels. The policy implication of these results is that the problem of food insecurity is still prevalence in the study area particularly with the alarming number of households that used derogatory management strategies as those of strategy 5 (Skipping of meals) and strategy 6 (Not eating for a whole day) constituting 31.7 and 9.3 percent respectively. Lastly, the results of this study has cast aspersion on the achievement of zero hunger target as being promoted by the United Nations based on high prevalence of risks and managements strategies including the most dreaded ones being employed by the households. Therefore to safe this situation, the spirit of the recommendations made shortly should be strictly adhered to.

REFERENCES

- FAO. (1974), “*World Food Summit*”, 1974, Rome, Italy
- FAO, (1983), “World Food Security: A Reappraisal of the Concepts and Approaches”, *Director General’s Report, Rome*.
- FAO, (1996), “Rome Declaration on World Food Security Summit Action Plan”, *World Food Summit* 13-17 November 1996. Rome.
- FAO, (2002), “The State of Food Insecurity in the World 2001, Rome”, available at: www.fao.org
- Gujarati, D. N. and Porter, D.C. (2009), “Basic Econometrics, 5th edition, McGraw-Hill, New York, 1999
- Kuwenyi, S, Kabuya, F.I and Masuku, M.B. (2014), “Determinants of Rural Households’ FoodSecurity in Shiselweni Region, Swaziland: Implications for Agricultural Policy”, *IOSR Journal of Agriculture and Veterinary Science (IOSR-JAVS)*. Vol. 7, Issue 11 Ver. III, pp. 44-50.
- McFadden, D. (1974), “Conditional Logit analysis of qualitative choice behavior”, *In Frontiers in Econometrics*, ed. P. Zarembka, 105–142. New York: Academic Press
- National Population Commission (2006), “Nigerian Population Census”, 2006 Populations Census Results for Osun State, National Population Commission, Abuja
- World Bank, 1986, “Poverty and Hunger,” *Issues and Options for Food Security in Developing Countries. Washington DC*.
- Wu, W., Yanga, P., Tanga, H., Youd, L., Zhoua, Q., Chena, Z. and Shibasaki, R. (2011), “Global-scale assessment of potential future risks of food insecurity”, *Journal of Risk Research*, 14:9, 1143-1160, DOI: 10.1080/13669877.2011.571794.

EXPLORING TALENT INDICATORS IN INTERNSHIP PROGRAMMES FOR HUMAN RESOURCE MANAGEMENT GRADUATES

Kelebogile Paadi, Nicolene Barkhuizen and Sonia Swanepoel
Global Innovative Forefront Talent Research Niche Area
North-West University, Mafikeng Campus
South Africa

ABSTRACT

The main objective of this research was to determine the talent indicators for Human resource management (HRM) graduate interns in internship programmes. A qualitative approach was followed. Data was gathered from semi-structured interviews with a sample of 25 HRM practitioners, managers and supervisors of graduate interns. The results showed that the most important talent indicators for graduate interns are interpersonal skills, performance and quality, accuracy and speed of work. Recommendations are made for the improvement of graduate internship programmes.

INTRODUCTION

Economies around the world especially in third world countries are not growing at rates conducive for sustainable job creation, making unemployment and especially youth unemployment a significant problem. South Africa in particular showed a record high youth unemployment rate of 54,5% by the end of 2016 (Trading Economics, 2017). Youth employment is compromised in the labour market due to a variety of factors such as work experience, financial constraints, job search abilities and a mismatch between available jobs and the skills they offer (Labour Force Survey, 2014). Unemployed university graduates are of great concern for the growth of the South African economy and with the ever changing labour market graduates need to be engaged in appropriate forms of work experience to build their technical and professional skills (Meintjes & Niemann-Struweg, 2011). Consequently government departments are encouraged to create training spaces such as internship programmes that will free most South Africans from inequality, unemployment, skills and poverty gaps (Ndzimande, 2015).

This research focuses on talent indicators for Human Resource Management graduates participating in a graduate internship programme. The human factor remains a big part of the human resource management profession. Human resources are the only organisational resource that can use other resources in the organisation to achieve its goals and objectives (Kahn & Louw, 2010). Certain skills and abilities are necessary to competently work with people. Many organisational problems have been associated with the HR department not doing its work properly or just not doing enough to manage people right (Schutte, Barkhuizen & van der Sluis, 2015). Human resource management graduates (hereinafter referred to as HR Graduates) should receive a well-rounded integrated programme that includes a wide variety of skills and knowledge to enable them to be competent enough in practicing HRM successfully after they have completed their internship programmes.

LITERATURE REVIEW

Overview of the graduate internship programmes

According to Williams (2015) higher education qualifications have the ability to open up many opportunities, but if they are not complemented by proper learning experiences they do not really have the potential to change lives and change societies. Learning opportunities are presented in Work Integrated Learning Programmes (WIL); they can take a form of internships, learnerships and apprenticeships offered by private and public organisations for qualified graduates in various disciplines.

Internship programmes are built with two objectives: firstly, to offer students an understanding of organizational structures within a professional working environment, and secondly to provide students with an opportunity for professional development (Abeysekera, 2006). The most common factor about internship programmes is their ability to expose graduates to a practical part of their discipline by providing relevant work experience (Tepper & Holtf, 2015).

According to Lain, Hadjivassiliou, Alza, Isusi, O'Reilly et al. (2014) graduate internships can be educational and non-educational. Educational internships take place within the learning environment of either universities or colleges and are necessary for a qualification to be awarded at the end of a programme. Non educational internships is when the intern voluntarily develops their skills according to their formal qualification and has a duration differing from organisation to organisation.

The benefits and challenges of graduate internship programmes are well documented. A study by Alson, Schutte, Barkhuizen and Paadi (2016) showed that WIL programmes enhance the employability and career path planning of students. WIL programmes also enhance the curricula of higher educations and reduce costs associated with the recruitment and selection of graduate interns (Barkhuizen & Schutte, 2014). Challenges associated with WIL evolve around mentorship involvement, the development and structuring of experiential learning and lack of stakeholder engagement (Pop, Swanepoel & Barkhuizen, 2013).

Exploring talent indicators in internship programmes

The global demand for talent (talented employees) has increased over the years as a result of changing and growing markets, demographics and mostly the high demand for the skilled labour or employees (Truss, Mankin & Kelliher, 2012). Originally talent management focused on addressing skills shortages in senior management positions (Truss et al. 2012) and later evolved into looking at 'key employees' or high potential employees who can advance to higher positions in organisations (Greenhaus, Callanan & Godshalk, 2010).

Armstrong (2012) defines talent as the skills, abilities and aptitudes of people that enable them to perform effectively in their roles and make a difference in organisational performance. Truss et al. (2012) believe that talent is "innate, genetically coded predispositions that create natural strengths and abilities within an individual". Talent therefore is different from skills which are tools, techniques and procedures that can be learned through instruction or experience.

Talent in this study refers to young graduates who are employed in internship programmes.

The questions however remain:

- Does the internship programme really serve its purpose?
- What about an intern graduate who is in the organisation for only twelve months?
- How are we going to measure their acquired competence within such limited time?

Moreover graduate interns know that after the programme the organisation normally selects some of them for permanent employment. Therefore they might perform to the best of their abilities during the internship and after being offered permanent employment, not meet initial performance expectations.

Competency requirements for graduate interns

Although competence and competency are two terms used interchangeably, there is a slight distinction between the two. Warnich, Carrell, Elbert and Hatfield (2015) define competence as a specific skill that an employee possess whereas competency refers to how an individual excels in a specific job position. Other researchers concur with this definition by referring to competencies as the underlying behavioral characteristics that can be measured and strategically developed through various human resource management systems to improve the overall organisational performance (Daniel, & Daniel, 2013).

Research into graduate competencies in the South African context remains scarce. A study by Ntsizwane, Barkhuizen and Swanepoel (2013) showed that factors such as professionalism, time management, ability/willingness to learn, communication and independence were the most important competencies to enhance the employability of graduates. Barkhuizen and Schutte (2014) highlighted the importance of technological knowledge and creating global citizenship for students.

The South African Board for People Practices (SABPP, 2014) developed a competency model for HR professionals made up of three broad competence areas. The SABPP is the recognised standards body for human resource management in South Africa. According to the SABPP (2014) the five core competencies for successful execution of HR roles are leadership and personal credibility, organisational capability, solution creation and implementation, interpersonal and communication ability and innovation, technology and sustainability.

Schutte (2015) developed and validated a HRM professional competence model for HR practitioners in South Africa. The competence model consists of three main competency domains which further consist of sub-competencies: Professional behavior and leadership (*i.e. Innovation, Leadership and Personal Credibility, Interpersonal Communication and Solution Creation*), Service orientation and execution (*i.e. Talent Management, HR Service Delivery, HR Metrics and HR Risk*) and Business Intelligence (*i.e. Strategic Impact, HR Business Knowledge, HR Business Acumen and HR Technology*).

According to Trede and McEwen (2012) the preparation of graduates for work roles should not only include disciplinary knowledge and technical skills but also behavioral competencies like working in teams, how to communicate with others, learn tacit ways working through observations and socialise into workplace cultures developing professional mannerisms and identity. HR work requires a high level of professionalism and ethical practice and the extent to which a graduate can master these early in their careers shows exceptional ability which translates into a talent indicator.

Towards a preliminary Talent indicator Framework

In the light of the previous discussion, the researcher developed a preliminary conceptual model for graduate interns. This model is presented in Figure 1 below.

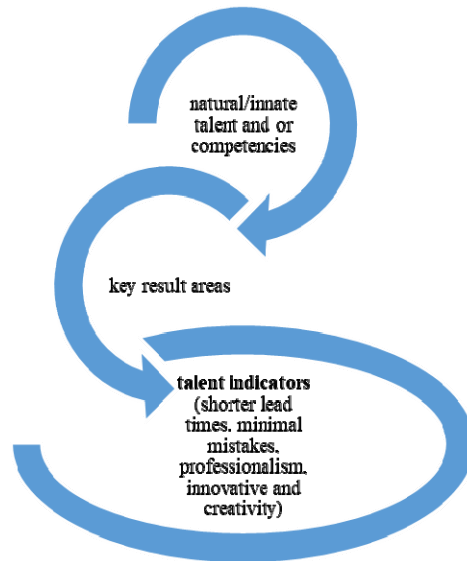

Figure 1: Conceptual model for exploring talent indicators in internship programmes (Researcher own)

This model starts from the premise a graduate can be regarded as a talent if their natural abilities, competence and competencies enable them to produce key results above the expected standards. Gerson (2006) defines high performance as significantly above average or high performers as people with a set of competencies that that can result in high performance exceeding the expected norm. According to Talsley (2011) early signs of talent can be used to predict future success. Early talent and potential detection in interns can assist them to carve a clear career path for themselves and with the motivation and guidance of their supervisors can motivate them for further development to increase their employability. The talent indicators would be achieving the results within shorter periods, producing them with minimal mistakes, ability to come up with innovative ways of doing things, professionalism and positive visibility.

RESEARCH DESIGN

Research approach

According to the De Vos, Strydom, Fouche and Delpont (2011) research designs are the steps that researchers undertake to achieve their anticipated research outcomes. This research followed a qualitative research approach whereby data was gathered by means of semi-structured interviews from the participants. Phenomenology was employed in this study to explore the experiences of the people involved to form a description (Maree, 2016). In this study talent indicators are explored from the view of the stakeholders involved in the graduate internship programme such as HR managers, supervisors and mentors as they can provide a more detailed evaluation of their experiences and observations of graduate interns.

Sampling

The target population for this study was stakeholders (i.e. HR managers, supervisors and mentors) involved in graduate internship programme for HR graduates. Although the anticipated target population was larger, data saturation was reached with a sample of 25 participants. Most of the participants in this sample were female (52%) and representative of the Black African ethnic group (52%). The participants were primarily employed on management level (68%), had between 5 and 10 years of work experience in the field of human resource management (56%) and were employed in the public sector (72%).

Data collection method

The data was collected using semi-structured interviews. Semi-structured questions assist researchers to guide participants in their discussions, which further allows for the systematic collection of data on a defined area of interest (Cresswell, 2014). The interviews were tape recorded to assist the researcher to draw correct conclusions from the responses. The quality and rigour of this research was ensured by peer debriefing whereby the results were benchmarked with another researcher who had no direct involvement in the study. This promoted the reliability and dependability of findings (Nguyen, 2008). Moreover the researchers stipulated their roles within the research and were cautious of any bias that could have resulted from personal and subjective viewpoints (Hadi & Closs, 2015).

Data analysis

Thematic analysis was used in this study to uncover the associations that existed across the phenomena and how these associations relate to the research setting (Leech & Onwuegbuzie, 2008). The themes are substantiated by verbatim quotes obtained from the interview participants' responses in this study. This was done in accordance with the contemporary qualitative research approach which entails the validating or supporting knowledge of the assumptions made in particular research settings (Bowen, 2009).

FINDINGS

The preliminary findings of this study showed that three main themes can be derived which represents talent indicators for graduate interns. The theme that was mentioned the most were Interpersonal skills (mentioned 8 times), followed by Performance management, performance standards and feedback (mentioned 7 times) and Quality, accuracy and speed of work (mentioned 3 times). A brief discussion of the themes are presented below.

Sub-Theme: Interpersonal skills

Most participants expressed that success is not in a silo and that is why interpersonal skills are important if one is to determine if a graduate shows talent potential. These are what some of the participants had to say:

“Commitment, availability and dependability” (P 6 - Male, Black, Deputy Director HR in the public sector)

and

“a competitive spirit may or may not be good at times, but a student that wants to be the best will make sure that they give their best performance, so yes competitiveness can indicate that there talent somewhere” (P 12 - Male, Black, Assistant Director HR in the public sector).

Sub-Theme: Performance Management

The view was that there is no formal performance management tool and rewards as compared to permanent employees - the contents of the intern contract (job description) serves as the basis for performance management. Most participants expressed that performance feedback (appearing second most) from supervisors, mentors and colleagues is important to determine the intern's potential. These are some of the responses from participants.

“They are not exposed to all areas of work so it makes it difficult to determine talent”... “The performance outcome determines the potential as there is no performance tool outside the expected outcome” (P 2 – black, female, HR Manager in the public sector).

and

“Thorough feedback sessions and discussions with their managers or supervisors on their performance is helpful, it gives different perspectives from both the intern and their mentor” (P 3 – white, female, HR Manager in the private sector).

and

“Departmental meetings where all line managers’ report on their sections status can reveal some information about the intern’s performance, positive feedback from two or three supervisors about one intern says a lot and as managers we can be able to make further recommendations” (P 19 – white, male, Director HR in the public sector).

and

“We have quarterly assessments that both supervisor and intern sign off on”... “Standards given to them assist as they have targets allocated, so if he/she performs above the given standard it can be seen as talent” (P 7 – black, female, assistant director in the public sector).

and

“Develop a work plan and observe them when they execute their duties, their attitude usually tells the supervisor something”... “as you know they say your attitude determines your altitude, many graduates do not like taking instructions, especially when they think they know more than us or are more qualified, if you cannot take instructions you cannot do the job well, same as you do not read a manual for a new gadget you will not be able to operate it properly” (P 5 - Male, Black, Senior Personnel Practitioner in the public sector).

Sub theme – Quality, Accuracy and Speed of work

Participants in this study also emphasised the importance of graduates to be able to deliver quality and accurate results in a timeous manner. Some of the quotes include the following:

“Through practical work application, graduates that can show an ability that what they have learned in university can be done in practice, you can tell there is something there” (P 6 - Male, Black, Deputy Director HR in the public sector).

and

“I once asked an intern to help me with a report document that was due in a short space of time, I tell you within a few hours she gave me a good document with a table of contents which I had not done and she showed me how to do it automatically from word which I use every day but did not know that function, I was impressed so the quality of work and ability to meet deadlines” (P 22 – female, coloured, personnel practitioner in the public sector).

DISCUSSION

The main objective of this research was to determine the talent indicators for HR graduate interns in internship programmes. As with previous research, the findings highlighted the importance of soft skills for graduates such as interpersonal skills (Trede & McEwen, 2012). The ability of graduate interns to perform on the job with speed and accuracy was also highlighted (see see Ntsizwane et al., 2013). However, as mentioned by the participants, organisations should create a conducive environment for graduate interns where they can apply what they have learned on the job and be able to perform according to set standards (Abeysekera, 2006; Tepper & Holtf, 2015). The need for a structured programme internship programme was also mentioned which in turn could guide the graduate through their career development and enhance their work experience and employability (Alson et al., 2016; Lain et al., 2014).

This research makes important theoretical and practical contributions. From a theoretical point of view this research added to the limited empirical knowledge that currently exist on the talent indicators for graduate interns in the HR profession. This research also highlighted that lack of a sound theoretical foundation that can guide the effective implementation of graduate internship programmes for HR graduates. This research makes an important practical contribution by revealing the required talent indicators that HR graduates should comply with if they want to become employees of choice within the HR fraternity.

This research had some limitations. First a qualitative research approach was followed and only focused on the HR profession. As a result the findings cannot be generalised to other professions. Furthermore this sample only focused on management and mentor perceptions of graduate internship programmes. For future research it is recommended that graduate interns included in the sample to obtain a more holistic view of talent capability requirements from the intern's point of view. Future research should also include other variables to obtain a more holistic view of the requirements of graduate internship programmes. Research can also benefit from determining the return on investment of graduate internship programmes for both higher education institutions and organisations. More research is needed to build a sound theoretical base for the application of graduate internship programmes.

In line with the preliminary findings it is recommended that mentors need to share information about their thoughts, work and experiences with interns so that they can turn it into meaningful knowledge they can use to be successful in the workplace. Interns do not have benefits like permanent employees, they have a few entitlements but with a little reward in the form of incentives they can be motivated to maximize their performance.

In conclusion, public institutions and government departments can use internship programmes to attract talent into the public service by improving their corporate image. Institutions of higher education should work together with the public service to monitor the administration of graduate internships which will make it easier to detect graduate satisfaction with internship programmes. Normally these individuals would already be in the service of the organisation with a proven record of their competencies and abilities.

REFERENCES

- Abeyssekera, I. (2006). Issues Relating to Designing a Work-integrated Learning Programme in an Undergraduate Accounting Degree Programme and its Implications for the Curriculum. *Asia- Pacific Journal of Cooperative Education*, 7(1), 7-15.
- Alson, N., Schutte, N.E., Barkhuizen & Paadi, K. (2016). *Benefits and challenges associated with the implementation of talent management programmes for human resource management graduate programmes*. Proceedings of the 10th International Business Conference, Langebaan South Africa, 24-28 September.
- Armstrong, M. (2012). *Armstrong's Handbook of Human Resource Management* (12th ed.). London: Kogan Page.
- Barkhuizen, E.N. & Schutte, N.E. (2014). *Work integrated learning: A Conceptual Model*. International Conference of Arts, Economics and Management, Dubai, UAE, pp. 11-15, ISBN 978-93-82242-82-86.
- Bowen, G. A. (2009). Supporting a grounded theory with an audit trail: An illustration. *International Journal of Social Research Methodology*, 12(4), 305-316.
- Creswell, J. W. (2014). *Research Design: Qualitative, Quantitative, and Mixed Methods Approaches* (4th ed.). Thousand Oaks, California: SAGE Publications, Inc.
- Daniel, R., & Daniel, L. (2013). Enhancing the transition from study to work: reflections on the value and impact of internships by employers and graduates in the creative and performing arts. *Arts and Humanities in Higher Education*, 12(2-3), 138- 153.

De Vos A.S., Strydom, H., Fouché C.B. & Delpont C.S.L. *Research at the grass roots for the social sciences and human service professions*. (4th ed). Pretoria: JL Van Schaik Publishers.

Hadi, M. A., & Closs, S. J. (2015). Ensuring rigour and trustworthiness of qualitative research in clinical pharmacy. *International Journal of Clinical Pharmacy*, 1-6.

Gerson, R.F. (2006). *Achieving High Performance – A research based practical approach*. Canada: HRD Press Inc.

Greenhaus, J.H, Callanan, G.A. Godshalk, V.M. (2010). *Career Management*. (4th ed.). California: Sage Publications.

Kahn, S.B. & Louw, V.N. (2010). Talent management for creating a performance work environment in the South African public service. *Africa Insight*. 40(2), 177-188.

Leech, N. L., & Onwuegbuzie, A. J. (2008). Qualitative data analysis: A compendium of techniques for school psychology research and beyond. *School Psychology Quarterly*, 23, 587-604.

Lain, D. Hadjivassiliou, K. Alza, A.C. Isusi, I. O'Reilly, J. Richards, V & Will, S. (2014). Evaluating internships in terms of governance structures: Contract, duration and partnership. *European Journal of Training and Development*, 38(6), 588 – 603.

Maree, J. G. (2016). *Research at the grass roots* (2nd ed.). Pretoria, Van Schaik.

Meintjes, C. & Niemann-Struweg, I. (2011). Corporate communication learner opinions of experiential learning for professional development in South Africa. *South African Journal for Communication Theory and Research*, 37(1), 173-189.

Nguyen, T. S. T. (2008). Peer debriefing: The Sage encyclopedia of qualitative research methods. Retrieved from <http://srmo.sagepub.com/view/sage-encyc-qualitative-research-methods/n312.xml>

Ntziwane, L., Swanepoel, S., & Barkhuizen, E.N. (2013). *Perceptions of Desirable Employability Skills for Commerce Students*. International Conference Proceedings of PSRC, Johannesburg. (pp. 126-130) ISBN 978-93-82242-50-5

Pop, C.A., Swanepoel, S., & Barkhuizen, E.N. (2013). The role of mentorship in the retention of graduate interns. *Alternations*, 8, 86-106.

Schutte, N.E. (2015). *The development of a professional Human Resource Management Competency model for Human Resource Management practitioners*. Unpublished Doctoral Thesis, Department of Industrial Psychology, North-West University, Mafikeng, South Africa.

Schutte, N.E., Barkhuizen, E.N., & van der Sluis, L. (2015). The validation of a human resource management professional competence model for the South African context. *South African Journal of Industrial Psychology*, 41, 1, 1-9.

South African Board for People Practices (SABPP). (2014). Internships - A Guide for Employers.

Statistics South Africa (2014). *National and Provincial Labour Market: Youth*. Pretoria, Statistics South Africa.

Tepper, R.J. & Holtf, M.P. (2015). *Unpaid Internships: Free Labor or Valuable learning experience*. Brigham Young University Education & Law Journal.

TradingEconomics (2017). South Africa youth unemployment rate. Retrieved from <https://tradingeconomics.com/south-africa/youth-unemployment-rate>

Trede, F., & McEwen, C. 2012. Developing a critical professional identity: Engaging self in practice. In *Practice-based education: Perspectives and strategies*, ed J. Higgs, R. Barnett, S. Billett, M. Hutchings and F. Trede, 27–40. Rotterdam: SensePublishers

Truss, C. Mankin, D. & Kelliher, C. (2012). *Strategic Human Resource Management*. New York: Oxford University Press.

Warnich, S., Carrel, M.R., Elbert, N.F. & Hatfield, R.D. (2015). *Human Resource Management in South Africa* (5th ed.). Cengage Learning: Hampshire, UK.

Welman, C. Kruger, P. & Mitchell, B. (2012). *Research Methodology* (3rd ed.). Cape Town, Oxford University Press Southern Africa.

Williams, S. (2015). *Job Creation and Economic Growth*. New African, IC Publications.

e-MARKETING & e-WOM STRATEGIES: CHALLENGES FOR GREEK HOTELIERS IN ZAKYNTHOS

Alexandra Palioura
University of Liverpool, UK

Shaukat Ali
University of Wolverhampton, UK

ABSTRACT

This paper examines the challenges faced by small/medium-sized hoteliers in the hospitality sector on the island of Zakynthos in Greece, assessing the way in which they perceive E-Marketing and in particular how online reviews published on social media affect traveller's intentions. Interviews of hoteliers provided qualitative data concerning the E-strategies practices currently adopted by hotels management in Zakynthos. The interviews indicated that E-Strategies are underdeveloped in the sector, with ICT technologies implemented but the marketing management opportunities of ICT currently are not being exploited. Furthermore, even though the relevant hotels are exposed to online reviews, their management of reviews is still passive. At the same time a survey of travellers in the area of Zakynthos indicated that travellers are exposed to e-WOM and reviews by previous travellers have a significant effect on their purchase intentions.

Keywords: e-Marketing, e-WOM, Zakynthos.

INTRODUCTION

The hospitality sector is highly dependent on inter and intra traveller information and the sector is focused on developing e-marketing practices that enable travellers to acquire needed information. Understanding the way travellers adopt and interpret information is therefore vital when developing e-marketing strategies (Sotiriadis and van Zyl, 2013, El-Gohary, (2010). The sector is characterised mainly by small and medium sized enterprises catering to local and international travellers. Greece is heavily reliant on the hospitality sector and implementation of e-marketing strategies, while imperative for the organizations, reveal challenges that need to be examined. One of the major challenges is communication, whether developed traditionally or through digital means (Mitropoulos, 2014).

e-Marketing tools vary and are highly related to the usage of internet while the implementation of e-marketing strategies can completely change the potential of the small medium sized organizations (El-Gohary, 2010). Word of Mouth communication has always been recognized as an important marketing tool in the tourism sector while the development of e-WOM has created different perspectives. The main purpose of this research is to understand and evaluate the effect and intensity of e-WOM, the behavioural patterns of travellers and the way online reviews affect them, the way consumers absorb online information and how such customers form their decisions.

Travellers have always been communicating their experiences from different destinations. This type of communication, prior to the internet, was synchronous and among people who already had relationships. Nowadays the introduction of digital communication has changed the way travellers are being informed about their options concerning their tourism destinations and inevitably has affected the way they form their decisions. e-WOM inevitably created new opportunities; online reviews available on social networks as well as the usage of social networks for the promotion of products related to tourism are one of the major concerns in organizations. In

particular research on the influence of social networks in product recommendation is of high significance for the developing of an e-marketing strategy (Krishnamurthy and Singh, 2005).

LITERATURE REVIEW

The value of word of mouth communication has been well recognized by both marketers and marketing researchers. Development of word of mouth communication requires the interpersonal action of at least two people that are sharing their thoughts and experiences (Gheorghe, 2012). Sales have always used advertising as a mean of communication but word of mouth moved things ahead since it enabled marketers to remove the threat of manipulation that consumers feel from pure advertising. Word of mouth can be categorized in the pre-decision and post-decision while post-decision is more effective since the advertised becomes an active member in spreading the information about the product. Speakers' motivation to speak about the product differs and depends mainly on the type of involvement the speaker has had with the product and the personal objectives, hence the basic categories are formed as those of product involvement, self-involvement, other involvement and message involvement.

The consequences of WOM communication can be enormous since the information spread can be either positive or negative (Haywood, 1989) which suggests that the information spread is more related to the psychological situation of the communicator, with the influential power of negative WOM being critical. On the other hand positive WOM creates brand loyalty (Gheorghe, 2012). Marketing managers, focusing both of these components, along with cost benefits of the implementation of WOM practices, are aiming to develop effective WOM strategies (Trusov *et al.*, 2009).

The integration of technology in today's modern society has created a completely new environment for the development of e-WOM. The significance and acceptance of e-WOM has steadily increased since the formation in 2004 of the Word of Mouth Association and practitioners consider that e-WOM has greater potential than traditional WOM (Trusov *et al.*, 2009). Traditionally word of mouth communication considers that consumers' behaviour is influenced by the personal interaction, however, the introduction of internet enabled consumers to share their opinions through various platforms that are independent of the organization, with the advantage of being asynchronous, not limited by geographical restrictions (Hennig-Thurau and Walsh, 2003) offers access to more information (Xie *et al.*, 2011). In the e-WOM interpersonal connection is missing, nevertheless, consumers develop a strong relationship that is based only on linguistic communication and that is why the dependency of e-WOM on the internet is considered to be the driving force of differences between WOM and e-WOM (Brown, Broderick and Lee, 2007). In the tourism sector, which is dominated by small enterprises, e-marketing strategies are of high value since e-WOM has been acknowledged to have a significant influence in the hospitality sector with the suggestion that e WOM should be analysed from both the perspective of the consumer and the organization (Cantallops and Salvi, 2014).

Consumers' involvement in e-WOM

The influential power of word of mouth communication imposes the need to understand the motives of customers to involve in such forms of communication. Early work by Dichter (1966) classified motivation under four clusters. Customers are getting involved in conversations about a product to 1) express their experience with the product, 2) to cover personal emotional needs 3) as an act of contribution and 4) because they are influenced by the message carried. Positive and negative word of mouth communication has different motivational factors in terms of self-fulfilment (Sundaram *et al.*, 1998).

WOM communication succeeds among people who have some sort of relationship. However, customers despite the fact that they are able to have comprehensive discussions, are able to interact with a limited number of people. There are no such constraints for e-WOM (Xie *et al.*, 2011). Motivational analysis on the e-WOM reveals that consumers are motivated differently in comparison to traditional WOM. Hennig-Thurau *et al.* (2004) identified the four segments of 1) consumers that have economic interests 2) consumers that have different motives 3) those that are interested in sharing their experiences and finally those that are highly altruistic.

Message is one the predominant variable that will ensure the effectiveness of e-WOM. Manuela and María, (2014) researched the influential power of certain message inside e-WOM communications. Their research concluded that credibility of e-WOM depends highly on the quality of the message. Furthermore the research pointed out that consumers are more willing to participate in platforms that are not operated by firms. Hence, the influential power of individuals is indisputable.

Travellers involvement in online reviews

The Internet has created a new ecosystem about the way people communicate (online reviews, blogs, e-mails etc) search for information and share their experiences. Bronner and Hoog (2010) researched the motivation of travellers and found that the choice of communication channel depends highly on the motivation of traveller. In particular travellers that are using consumer generated platforms are generating positive comments and are more willing to provide any kind of information that will help other travellers. On the contrary, those that prefer marketing generating platforms are more self-directed and are keen on providing negative comments. Finally, travellers with low altruistic motives are contributing in mixed generated platforms. Bearing in mind that people search for information independently of the motivational cluster, the research showed the profound impact of online reviews on traveller's decision process.

Consumers are willing to participate in e-WOM because they want to mitigate the associated risks of purchasing a product and achieve to do it in a timely manner (Hennig-Thurau and Walsh, 2003). An analysis of the influence of WOM and e-WOM through social networks indicated that e-WOM has a significant impact on customer's decisions (Trusov *et al.*, 2009; Connor, 2010).

Social networks provide proliferation of information and that consequently raises the issue of credibility. Research by Sparks *et al.*, (2013) indicates that the perception of travellers over the organizations credibility is affecting the purchasing intentions when assessing the credibility of information, both in terms of the source of the message as well as the content.

Filleari and McLey (2014) sought to identify the way travellers evaluate the available online information prior to coming to final decisions concerning available touristic options. The authors highlighted that the usage of user-generated platforms increases and as a result it is essential to understand the customers' behaviour in e-WOM. The research revealed that the product ranking, a new concept in the research of e-WOM, plays a significant role in the decision process of travellers. The quantity of online available information is not of significance for travellers while the quality of the available information plays an incremental role. Finally, relevancy of the information is one of the influential factors in forming traveller's opinion. The practical implications of the study are of high importance for e-marketers, product ranking reveals that formation of product clusters is important in developing customers' opinions because customers will acquire knowledge that is relevant to their intentions and behaviour.

Ayeh *et al.* (2013) conducted a research in order to identify the credibility of user generated platforms. The integration of these in the tourism sector indicates the importance of understanding the credibility of those systems because these can be manipulated by either consumers or owners of tourism, creating concerns over their credibility. The authors' analysed credibility in terms of how believable is the online information; the dimensions of trustworthiness and expertise were those that conceptualized credibility while homophile theory was used in identifying the clusters of people with similar attributes and behaviors. The research revealed that credibility when using such systems is more influenced by the variable of trustworthiness, people might neglect the dimension of expertise if they consider that the information source is reliable. The practical value of the study is important for marketing managers in tourism, since it reveals the way travellers interpret credibility of the available information. For the platform operators an indicator of what enhances customers' perception of trustworthiness enables the development of mechanisms that will secure the credibility of the available information

Litvin *et al.* (2008) discuss ways marketers can mitigate risks associated with the usage of e-WOM through the development of marketing strategies. They stress the new challenges for those who are active in the tourism sector and indicate that even though e-WOM tools are cost effective there are ethical and practical issues to be addressed deriving from the credibility of the available online information. In reference to the available e-WOM

tools their research indicates that marketers should focus on the special characteristics of each tool and accordingly develop management practices. The ethical concerns that were discussed in the paper revealed the challenges of customers being misled either purposely or not.

Recent studies indicate that the factors of demographics, review message and perception about the trustworthiness are imperative during the process of assessing the impact of e-WOM. Those factors are incremental on the development of marketing strategies and are examined in reference to the customers' decisions process. Taking these into consideration it is apparent that both the perspective of the customer and of the organization is of high importance in evaluating the influence of the e-WOM. However, customer's personal beliefs and perceptions are important in evaluating the hospitality services and that is why the variable of nationality should be co-evaluated when examining the impact of e-WOM (Cantallops and Salvi, 2014).

Challenges for SME's in the tourism sector

Extensive research by academics and marketing professionals has been conducted to investigate the value of word of mouth and the effectiveness of the applicable techniques (Tag-Eldeen, 2012). Effective word of mouth is based on opinions that add value to the product or the service. Such communications occur and progress after the products are purchased and consumer opinions are considered as a post purchase liberal information activity that gives rise to their motivation, intention and frank talk (Kumar, Petersen, and Leone, 2007).

Several terms are used associated with e-WOM techniques, such as viral promotion, interactive process, referral development, review channeling and so on (Tag-Eldeen, 2012). The term viral marketing differs from the traditional word of mouth because it concentrates more on the attractiveness of the opinion, hence the number of consumers that are attracted (Phelps *et al.*, 2004). Interactive marketing on the other hand created a new marketing technique, under which the interaction between organizations and consumers are able to communicate independently of time and location restrictions through the usage of internet (Barwise and Farley, 2005).

Organizations are turning to the Internet, aiming to achieve a competitive advantage however are struggling with implementation strategies. Customer relationship, as an organizational process that enhances the effective conversation through online activities, is part of marketing management and social media and networks are moving things a step further, enhancing the effectiveness of communication. Tag-Eldeen, (2012) conducted research in the Egyptian hospitality to understand the factors that influence the customers' decisions in reference to e-WOM and to evaluate the management responses to future activities in reference to e-WOM. The results indicated that specifically in Egypt all travellers are extremely interested in the e-WOM which pinpoint that e-WOM as a tool of the marketing management for advertising is important. Furthermore, the research highlighted that management should identify new methods to implement, analyse and promote word of mouth. Another important issue that emerged from the research is credibility of the electronic word of mouth. Managers recognized the influence of the word of mouth on customers' decisions in the hospitality sector of Egypt and acknowledged the importance of developing new marketing and promotional techniques that would anticipate the drawbacks of the traditional word of mouth (Tag-Eldeen, 2012). Improvements on the techniques as part of operations management should aim to achieve the market and the financial objectives of the business. Furthermore, the implementation of procedures through internet enables them to interact effectively and resolve previous mistakes and drawbacks occurring due to traditional word-of-mouth techniques.

The development of an active community that involves interaction between the hospitality community and consumers has assisted hospitality and tourism industry managers to understand the effective style of sending messages that will increase the brand loyalty and increase the positive effects of word of mouth (Tag-Eldeen, 2012). It is observed that interaction of the business with customers in virtual communities has significantly positive results and affect various aspects of the organization. Customers apart from becoming more loyal contribute in expanding the brand awareness, in this way viral marketing is developed (Yeh and Choi, 2011).

Developing an e-WOM working methodology and communication offers a medium sized firm proficiency in penetrating and developing the market. Any hotel can establish a personal and official side of the page on the twitter and Facebook to assess the consumer interaction in the promotional game and find the ROI value in

exchange for e-WOM. Such method can, in fact, permit them to further interact mutually considering several other social gains and benefits by asking questions, seeking advice, offer tips and provide solutions, consider giving purchase advice and help other consumers offer the best buy solutions and thus help the company promote the products.

An experimental research conducted by Starbucks indicated that vividness and consensus of the messages delivered to the receiver will contribute in the attributes of the receivers (Chang and Wu, 2013). By combined the Attribution Theory and the Yale Model they evaluated the source, message and characteristics of the receiver (Chang and Wu, 2013). Those characteristics are forming the perception of the receiver in terms of credibility, which in the end form consumers' behaviour in social networks (Chu and Kim, 2011). Another important finding is that organizations through developing their own communication network can form a database enabling them to eliminate the effects of negative e-WOM; the conclusion being that organizations should develop policies and strategies that ensure brand commitment so that they contribute in mitigating and alleviating the effect of negative e-WOM (Chang and Wu, 2013).

Hospitality sector of Greece

The introduction of ICT technologies has created a revolution in the tourism sector; communication and transmission of information are now being conducted faster and without being limited by geographical restrictions (Kyriakou *et al.*, 2015). The introduction of web 2.0 services has contributed even more actively to the reformation of the tourism industry. The reshaping of tourism was inevitable since tourism is heavily dependent on information diffusion; however, the hospitality sector of Greece is still underdeveloped. The underdevelopment of e-WOM as a part of e-commerce in Greece is mainly occurring due to structural inefficiencies in governmental and private organizations. The government has not promoted the implementation of e-commerce effectiveness, whilst small and medium-sized organizations are lacking competencies to develop e- marketing strategies (Buhalis and Deimezi, 2004).

The development of new services creates new potentials for the tourism industry since it enables organizations to interact actively with their customers. However, those processes require high technological expertise and in-depth understanding of the market (Sigala, 2012). The Greek hospitality sector has for some time thought to have lost its competitiveness with marketing management strategies being anachronistic and contributing in creating the image of a cheap destination. Enterprises active in the hospitality sector have been found to be making the least usage of the internet due to their high dependency on the local market, despite a recognition they needed to expand internationally. Generally the Greek hospitality sector was found to be suffering from a lack of expertise in e-commerce and that was why the development of e-marketing strategies was moving forward slowly (Buhalis and Deimezi, 2004). Ten years on, a comparative research between China and Greece in the implementation of ICT developed by Kapiki and Fu (2015) revealed that in China the implementation of ICT systems is imperative since the Chinese tourist are highly depended on the internet and demand the communication to be conducted only in Chinese, on the contrary in Greece the requirement is for the implementation of only 5 ICT systems :guest security systems; website development with booking engine; on-line guest satisfaction evaluation; high-speed/WiFi Internet; and property management. Sigala (2012) aiming to understand the situation of web 2.0 services in Greece revealed that the Greek hospitality sector is collaborating with the customers mainly through the usage of user generated platforms while the information collected is used only for the evaluation of guest satisfaction. Another important finding is that the e- marketing strategies in Greece was not promoting the collaboration and the cooperation between the organizations and the customers (Sigala, 2012).

Noting the development of e marketing strategies require a financial investment from both governmental and private organizations, Kyriakou *et al.* (2015) investigated the potentials of investing in social media in Greece. The authors analysed the reformation of tourism industry internationally as a result of the introduction of internet services, and highlight that travellers now are looking for information that will transmit the experience of the destination. The analysis was conducted under two dimensions, one aimed to identify the contribution of social media in the tourism industry and the other the importance of experience for the modern tourists. Social media and experiential tourism are investigated in reference to the Greek hospitality from the perspective of both governmental and private organizations (Kyriakou *et al.*, 2015). The findings of the research revealed that independently of the

type of WOM (positive or negative) investment on social media to promote experiential tourism would be beneficial for the hospitality sector of Greece. However they highlight that social media should be used as a means to develop e-marketing and to facilitate communication with the tourist and should transmit the experience of current travellers to future ones (Kyriakou *et al.*, 2015).

Development of e-marketing strategies in the tourism sector apart from great potential uncovers many challenges for the marketers. Management of the collected data can be interpreted from the perspectives of information acquisition or of revenue generation. From the perspective of information acquisition managers can understand the level of satisfaction and develop strategies to enhance the traveller's satisfaction while positive feedback of e-WOM can contribute to revenue generation (Chi and Qu, 2008). Nevertheless, e-marketing needs to be developed under certain ethical boundaries that managers should recognize and respect. e-Marketing provides marketers with the advantage of developing cost-effective strategies but if for example the data collected is not protected and used with respect towards the customer then apart from the ethical concerns there is the possibility of producing a rebound effect on consumers behaviour (Chi and Qu, 2008).

METHODOLOGY

A questionnaire and interviews formed the methods for this exploratory study. For the survey a 5 point likert scale was used for the following dimensions: Online reviews, Quality of online reviews, Expertise, Trustworthiness. The online program "e.surv.org" was used to craft and send a questionnaire online and 13 responses were utilised. Five face to face interviews were conducted with hotel owners in the area of Zakynthos. The duration of the interviews was of about 30 to 50 min. Interviews sought views around two key areas: What is the current situation in the management practices of e-WOM in the hospitality sector of SME's in Zakynthos? How do SME's manage negative e-WOM.

ANALYSIS & DISCUSSION

Results and discussion of interviews

The understanding of e-WOM management practices were investigated during the interviews and different viewpoints emerged. All of the respondents showed a good understanding of the impact of e-WOM, however the practices of e-WOM strategies seemed to differ drastically between the hotels even though the hotels share similar characteristics in terms of size, management capabilities, nationalities of travellers and period of operation. All of the hotels mainly focused on the online reviews but only three were actively collecting data that was used proactively.

The literature review indicated that the tourism sector has been transformed by the prevalence of the Internet especially the introduction of web 2.0. Findings of the interviews are in agreement with this, with one of the hoteliers indicating that

"...Indeed internet has changed the way we perform and contributed in increasing our revenues but I cannot give exact figures about this..."

All the hoteliers acknowledged the potential provided by the Internet, similar to the finding of Tag-Eldeen, (2012) and appear to have implemented ICT technologies. However these are mainly focused facilitation of the everyday management of the hotel. Only one of the hoteliers implemented ICT technologies aiming to actively communicate with the customers. Those findings are in agreement with the comparative research between Greece and China made by Kapiki and Fu (2015) that highlighted that Greek hoteliers are concentrated only in 5 ICT systems.

Furthermore, it was pointed out that the implementation of Internet has affected the purchasing decision of travellers due to online reviews as mentioned by Trusov *et al.*, (2009). The power of social media sites such as Trip

Advisor, was acknowledged by the hoteliers interviewed since all of them are members of at least one social media platform, however only one of the hoteliers has a strategy on actively using social media.

The usage of online reviews among hoteliers varies, but with exception to one hotelier the rest either has no particular policy or are acting passively. Interviewers replied in various ways in reference to the negative online reviews. One said:

“...I do not reply to none of them. I am pleased to see the positive review. I only have two negative reviews since I try to be proactive and solve any sort of failure early enough...”

Another interesting reply was:

“...Only what is published on the website of Trip Advisor. However, we don't have complaints published. We try to work any kind of problem during the period of accommodation....”

The hotelier who is actively interacting through social media replied that:

“...We are looking for online reviews and online ratings, which as I told you, [they] are important for the reputation of the hotel....”

While the same interviewer explained that in the case of negative reviews, the hotel has developed a policy for resolving the situation:

“...Well, the policy is that even when there is a negative review we ought to answer within 48 hours. My idea is that even when the customer is not so fair, I am going to reply apologize and show professionalism in the way I treat them...”

The implementation of e-commerce being underdeveloped is in compliance with the findings of the interviews. As the literature revealed (Sigalas, 2012) even when social media are implemented in the hoteliers marketing strategies, the hoteliers are only concerned about the satisfaction of the customers; management is not using social media platforms to promote cooperation between hotels and customers nor actively developing e-marketing strategies.

One of the challenges faced by the hoteliers in Zakynthos is the credibility of the comments published on social media. Three of the hoteliers with experience of negative online reviews highlighted that the objectivity of the comments is a critical issue. One hotelier in particular said that:

“...I think that it is helpful but sometimes blurs objectivity due to cultural differences. In the example the misunderstanding occurred because English people took for granted that a high rated hotel includes a swimming pool...”

Identifying the source of the anachronistic usage of Internet is important. Interviewers admitted that lack of expertise. For instance one of the hoteliers replied that:

“...Developing e-WOM communication will contribute to the increase of revenues but requires financial investments and employment of expertise, which we cannot afford since we are a family business ...”

This was a recurring theme however this is a structural issue because hotels are mostly family run, with and limited resources, reliant on what expertise the families themselves have.

Results of the questionnaires

In the survey 13 responses were received from 3 nationalities (4 Czech, 2 Polish & 7 Greek). The sample was split between 4 males and 9 females. All of the participants were below the age of 40 which indicates that they were accustomed to Internet usage. Most of the participants vacationed once per year and organised their own arrangements.

The integration of Internet has altered communication; it presented customers with opportunity to research for information from various electronic sources. The research revealed that the dominant source of information is the Internet, providing marketers with various tools that constitute e-marketing (Shuai and Wu, 2011). Social networks

are vital for the implementation of E-WOM practices since they contribute to the diffusion of information (Krishnamurthy and Singh, 2005). The research indicated that travellers are open to e-WOM communication since 92% of them are members of several kinds of social networks.

The motivation of travellers is of high importance when selecting the electronic source of information (Bronner and Hoog, 2010). The variation of the information sources (Table 1) along with the fact that only 62 % of them are searching information through Hotel reviews sites or travel platforms (such as Trip Advisor) is in agreement with the findings of the literature.

Table 1: Sources of Information

Websites	Review Sites	Travel forums	Personal Travel blogs	Traditional word of mouth
42.86%	21.43%	10.71%	3.57%	21.43%

Cantalops and Salvi (2014) indicated that nationality is important when analysing the customers' intention. Personal beliefs and cultural background are affecting the way travellers interpret the available information. According to the research findings, indeed nationality is influencing travellers' choice. There is a variation of preferable electronic sources based on the nationality of the participant.

Table 2: Preferable electronic sources and nationality

	Websites	Review sites	Travel forums	Travel blogs	Traditional word of mouth
Czech	4	2	1	1	3
Greek	7	3	2	0	3
Polish	1	1	0	0	0

Useful information and convenience are the motivational factors of those that are searching online reviews. Hennig-Thurau and Walsh (2003) supported that people are getting involved in online reviews because of the facilitation of Internet and the quantity of information that can be retrieved in a timely manner.

With regard to quality of the information the participants were somewhat sceptical. Only one participant strongly agrees that the online reviews provide useful and updated information, while 6 of them had a neutral perception and 6 were positive about the information provided online. Even though literature suggests that the information available through social networks is widely accepted (O'Connor, 2010) travellers are hesitant. Research suggests credibility of information depends mainly on the source of information and the message delivered (Sparks *et al.*, 2013). This is in agreement with the findings of the survey. Most of the participants trust Trip Advisor because according to their beliefs it provides helpful information. On the other hand subjectivity of the message is a major concern for the participants. Research by Filieari and Mc Ley (2014) indicated that quality of the message on an online survey is of high importance. Nevertheless, the survey indicated that indeed the power of online reviews is inevitable. Participant purchasing decisions can be affected by previous reports, while they are open in reviewing messages that are providing objective information about the quality of the service. The choice of communication channel in e-WOM depends highly on the motives of individuals (Bronner and Hoog 2010). Nevertheless; personal opinions are more valuable than those generated by management platforms (Manuela and Maria 2014) which are in agreement with the findings of the survey. An important finding for the management of the tourism sector is that most of the participants have a positive perception of the e-WOM and are willing to participate but under conditions as they had ethical concerns about management usage of the information. Participants are willing to contribute to e-WOM provided the management is going to consider the information valuable and the information is going to be used actively. Almana and Mirza (2013) concluded that online reviews are important when people are seeking for purchasing options in their travel plans. The research indicated that indeed customers in the hospitality sector are using online reviews prior to making decisions concerning their vacations. However, taking into consideration the statements review customers are showing reluctance due to the reliability or the usefulness of online reviews.

Table 3: Usage of online reviews

	Strongly Agree	Agree	Neutral	Disagree	Strongly Disagree	N
I use online reviews for selecting a hotel	30.77%	30.77%	38.46%	0%	0%	13
I believe that customers review provide reliable and updated information	7.69%	46.15%	46.15%	0%	0%	13
I believe that online reviews is a trustworthy way of getting information	15.38%	23.08%	61.54%	0%	0%	13

Another interesting point of the survey is the perception of travellers concerning the importance of expertise and trustworthiness. Litvin *et al.* (2008) highlighted that the purchase decisions of customers are influenced by expertise. Equally hand trustworthiness of online reviews is of high value as noted by Cantallops and Salvi (2014). The survey agrees with the findings that expertise is more important when evaluating the online content but indicates that participants are suspicious about the online content.

Table 4: Expertise

N =13, percentage SA/D = strongly agree/disagree	SA	Agree	Neutral	Disagree	SD
I believe that popular review sites (Trip Advisor) have helpful information	23.08	69.23	7.69	0	0
The frequency of reviews from an reviewer represents his expertise	0	53.85	23.08	23.08	0

Table 6: Trustworthiness

N =12, percentage SA/D = strongly agree/disagree	SA	Agree	Neutral	Disagree	SD
I believe that if different reviewers describe the same situation similarly, then the situation described represent reality.	16.67	50.00	25.00	8.33	0
I believe reviewers must provide honest information.	25.00	41.67	16.67	8.33	8.33

Implication for the management

The research revealed that the implementation of e-WOM communication in the management of hotels provide opportunities of expansion and prosperity. In Greece the integration of e-WOM is still underdeveloped and for this reason the contribution of the research is valuable for the management of hotels in Zakynthos. The practical recommendations are taking into consideration consumers purchasing intentions, as a result of online reviews, developed in the first part of the research. The main practical contribution is that online content has a significant influence on traveller's perception about a possible destination. The research indicates that the integration of ICT technologies in the marketing management is imperative. Social media, Websites, chat rooms and e-mails constitute

the available electronic channels of e-WOM (Litvin *et al.*, 2008). Marketers achieve better diffusion of information when they are actively implementing those channels. Another important implication of the research is that the content of message is important and can either enhance or jeopardize the credibility. Customers–hotel communication provides hoteliers with the opportunity to create relationships that will enable the diffusion of information and ensure that travellers have access to reliable information. Furthermore management of online reviews is enhancing the credibility of the message. Management of online reviews requires the implementation of proactive marketing practices by hotels. Loyalty programs that reward current travellers for bringing new customers, encouragement of loyal customer to participate on online reviews are examples of e-WOM management in the hospitality sector that could be used. Research has shown that developing strategies in improving the communication not only in terms of practices but also in the meaning transmitted is essential for marketers. Especially in the hospitality sector, where the service provided is intangible, and the evaluation is based on one’s personal experience, marketers should be able to provide a more reliable content.

LIMITATIONS OF THE RESEARCH

The main limitations of the research were the limited sample of hotels interviewed and the number of participants taking part in the survey. It was only possible to interview 5 hotels in a restricted geographical area of Zakynthos, whilst at the same time, due to time restrictions narrow sample of travellers took part in the survey. Hence, further research on the hospitality sector of Zakynthos is required with a larger sample set. The research also mainly focused on online reviews so wider media can be further explored. Another critical issue of the research is the effect of online reviews on the purchasing intention of travellers. There are possibilities for future research on the effect of reviews on travellers that have completed their decision process.

REFERENCES

- Alexandris, K., Dimitriadis, N. and Markata, D. (2002) ‘Can perceptions of service quality predict behavioral intentions? An exploratory study in the hotel sector in Greece’, *Managing Service Quality: An International Journal*, 12(4), pp. 224-231.
- Almana, A.M. and Mirza, A.A. (2013) ‘The impact of electronic word of mouth on consumers’ purchasing decisions’, *International Journal of Computer Applications*, 82(9), 23-31.
- Arndt, J. (1967) ‘Role of product-related conversations in the diffusion of a new product’, *Journal of Marketing Research*, 4(3), pp. 291-295.
- Ayeh, J.K., Au, N. and Law, R. (2013) “‘Do we believe in TripAdvisor?’ Examining credibility perceptions and online travellers’ attitude toward using user-generated content’, *Journal of Travel Research*, 52(4), pp. 438-452.
- Barwise, P. and Farley, J.U. (2005) ‘The state of interactive marketing in seven countries: interactive marketing comes of age’, *Journal of Interactive Marketing*, 19(3), pp. 67-80.
- Bronner, F., and Hoog, R. (2010) ‘Vacationers and eWOM: Who posts, and why, where, and what?’, *Journal Of Travel Research: A Quarterly Publication Of The Travel And Tourism Research Association*, 50(1), pp. 15-26.
- Brown, J., Broderick, A.J. and Lee, N. (2007) ‘Word of mouth communication within online communities: Conceptualizing the online social network’, *Journal of Interactive Marketing*, 21(3), pp. 2-20.
- Buhalis, D. and Deimezi, O. (2004) ‘E-tourism developments in Greece: Information communication technologies adoption for the strategic management of the Greek tourism industry’, *Tourism and Hospitality Research*, 5(2), pp. 103-130.

- Cantalops, A.S. and Salvi, F. (2014) 'New consumer behavior: A review of research on eWOM and hotels'. *International Journal of Hospitality Management*, 36, pp. 41-51.
- Chi, C.G.Q. and Qu, H. (2008) 'Examining the structural relationships of destination image, tourist satisfaction and destination loyalty: An integrated approach', *Tourism management*, 29(4), pp. 624-636.
- Dichter, E. (1966) 'How Word-of-Mouth Advertising Works', *Harvard Business Review*, 44(6), pp. 147-166.
- El-Gohary, H. (2010) 'E-marketing: A literature review from a small businesses perspective', *International Journal of Business and Social Science*, 1(1), pp. 214-244.
- Filieri, R. and McLeay, F. (2014) 'E-WOM and accommodation an analysis of the factors that influence travellers' adoption of information from online reviews', *Journal of Travel Research*, 53(1), pp. 44-57.
- Gheorghe, I.R. (2012) 'Word-of-mouth communication: a theoretical review', *Marketing and Management of Innovations*, 1, pp. 132-139.
- Haywood, K.M. (1989) 'Managing word of mouth communications,' *Journal Of Services Marketing*, 3(2), pp. 55-67.
- Hennig-Thurau, T., and Walsh, G. (2003) 'Electronic word-of-mouth: Motives for and consequences of reading Customer articulations on the internet', *International Journal of Electronic Commerce*, 8(2), pp. 51-74.
- Hennig-Thurau, T., Gwinner, K.P., Walsh, G., and Gremler, D.D. (2004) 'Electronic word of mouth via consumer-opinion platforms: What motivates consumers to articulate themselves on the internet?', *Journal of interactive marketing*, 18(1), pp. 38-52.
- Kapiki, S.T. and Fu, J. (2015) 'E-hospitality strategies enhancing competitiveness: Evidence from China and Central Macedonia, Greece', in Hayden Collins, K. (ed.) *Handbook on Tourism Development and Management*. New York: Nova Science Publishers, pp. 165-190.
- Koutsokostas, S. (2016) *At what extent social media marketing influence on brand loyalty? Evidence from hotel industry*. MSc thesis. International Hellenic University. Available at: https://repository.ihu.edu.gr/xmlui/bitstream/handle/11544/14507/s.koutsokostas_msc.pdf?sequence=1 (Accessed: 9 January 2017).
- Kumar, V., Petersen, J.A. and Leone, R.P. (2007) 'How valuable is word of mouth?', *Harvard Business Review*, 85(10), pp.139-144.
- Kyriakou, D., Mpregkou, M., Grigoriou, I., Blanas, N., Belias, D. and Koustelios, A. (2015) 'Rethinking of experiential tourism through social media: Could Greece keep up the pace?', *10th MIBES - Management of International Business & Economic Systems Conference*. Technological Educational Institute of Thessaly, Greece, 15th-17th October, pp. 281-293.
- Litvin, S.W., Goldsmith, R.E. and Pan, B. (2008) 'Electronic word-of-mouth in hospitality and tourism management', *Tourism management*, 29(3), pp. 458-468.
- Manuela, L., and María, S. (2014) 'Determinants of E-WOM influence: The role of consumers' internet experience', *Journal Of Theoretical And Applied Electronic Commerce Research*, 9(1), pp. 28-43.
- Mitropoulos, C. (2014) 'Greek hospitality industry ripe for innovation'. PwC report. Available at: https://www.iit.demokritos.gr/sites/default/files/isl_ws/02_greekhospitality_dr_costas_s_mitropoulos_0.pdf [Accessed: 9 January 2017].

- O'Connor, P. (2010) 'Managing a hotel's image on TripAdvisor', *Journal of Hospitality Marketing & Management*, 19(7), pp. 754-772.
- Park, D. and Lee, J. (2008) 'eWOM overload and its effect on consumer behavioral intention depending on consumer involvement', *Electronic Commerce Research and Applications*, 7(4), pp. 386-398.
- Phelps, J.E., Lewis, R., Mobilio, L., Perry, D. and Raman, N. (2004) 'Viral marketing or electronic word-of-mouth advertising: Examining consumer responses and motivations to pass along email', *Journal of advertising research*, 44(4), pp. 333-348.
- Rao, C.P. and Singhapakdi, S. (1997) 'Marketing ethics: A comparison between services and other marketing professionals', *Journal of Services Marketing*, 11(6), pp. 409-426.
- Shuai, J.J. and Wu, W.W. (2011) 'Evaluating the influence of e-marketing on hotel performance by DEA and grey entropy', *Expert Systems with Applications*, 38(7), pp.8763-8769.
- Sigala, M. (2012) 'Exploiting Web 2.0 for new service development: Findings and implications from the Greek tourism industry', *International Journal of Tourism Research*, 14(6), pp. 551-566.
- Sotiriadis, M., and van Zyl, C. (2013) 'Electronic word-of-mouth and online reviews in tourism services: The use of twitter by tourists', *Electronic Commerce Research*, 13(1), pp. 103-124.
- Sparks, B.A., Perkins, H.E. and Buckley, R. (2013) 'Online travel reviews as persuasive communication: The effects of content type, source, and certification logos on consumer behavior', *Tourism Management*, 39, pp. 1-9.
- Stokes, D. and Lomax, W. (2002) 'Taking control of word of mouth marketing: The case of an entrepreneurial hotelier', *Journal of Small Business and Enterprise Development*, 9(4), pp. 349-357.
- Sundaram, D.S. Mitra, K. and Webster, C. (1998) 'Word-of-mouth communications: A motivational analysis', in Alba, J.W. and Hutchinson, J.W. (eds.) *NA - Advances in Consumer Research Volume 25*. Provo, UT: Association for Consumer Research, pp. 527-531.
- Tag-Eldeen, A.A. (2012) 'Assessment of electronic word-of-mouth on customers' purchasing decisions of hospitality services in Egypt', *2nd Advances in Hospitality and Tourism Marketing & Management (AHTMM) Conference*. Corfu Island, Greece, 31st May-3rd June.
- Travel and tourism economic impact 2015 Greece* (2016) Available at: [http://www.wttc.org/-/media/files/reports/economic impact research/countries 2015/greece2015.pdf](http://www.wttc.org/-/media/files/reports/economic%20impact%20research/countries%2015/greece2015.pdf) [Accessed: 9 Jul. 2016].
- Trusov, M, Bucklin, R, and Pauwels, K. (2009) 'Effects of word-of-mouth versus traditional marketing: Findings from an internet social networking site', *Journal Of Marketing*, 73(5), pp. 90-102.
- Xie, H.J., Miao, L., Kuo, P.J. and Lee, B.Y. (2011) 'Consumers' responses to ambivalent online hotel reviews: The role of perceived source credibility and pre-decisional disposition', *International Journal of Hospitality Management* 30(1), pp. 178-183.
- Yeh, Y. and Choi, S. (2011) 'MINI-lovers, maxi-mouths: An investigation of antecedents to eWOM intention among brand community members', in *Journal of Marketing Communications*, 17(3), pp. 145-162.
- Yoo, C.W., Sanders, G.L. and Moon, J. (2013) 'Exploring the effect of e-WOM participation on e-Loyalty in e-commerce', *Decision Support Systems*, 55(3), pp. 669-678.
- Yoon, S.J., (2012) 'A social network approach to the influences of shopping experiences on e-wom', *Journal of Electronic Commerce Research*, 13(3), pp. 213-223.

THE NOTION OF OMNI-CHANNEL RETAILING IN THE FASHION INDUSTRY

Elena Patten
DHBW Heilbronn, Germany

Wilson Ozuem
University of Gloucestershire, UK

ABSTRACT

The consumers' purchasing behaviour has changed tremendously with the development of E-Commerce. Consumers nowadays tend to switch retail channels during their purchasing process. In order to address changing consumer behaviour, multichannel fashion retailing companies still need to learn how to be able to provide a seamless interaction with customers through multiple channels. In this context, the term 'omni-channel retailing' can be considered as the most advanced stage of a multichannel-retailing system, implying full customer interaction and retailer integration. The coherent design of a multichannel-retailing system is deemed a strategic managerial decision for multichannel retailers. The purpose of this chapter is therefore to provide some insights about the concept of multichannel integration considering the different elements of the retail-mix.

Keywords: Channel Integration, Consumer Behaviour, Multichannel Retailing, Retail-Mix Strategies, Shopping Experience.

INTRODUCTION AND BACKGROUND

Retailing has changed fundamentally during the last decade (Neslin et al., 2006; Zhang et al., 2010). This development was mainly driven by technological and societal factors (Emrich, 2011). In this context, E-commerce was probably the most important technological invention. Currently, 80.7 per cent of European households have Internet access (Statista.com, 2016). According to two independent studies by the Internet Advertising Bureau UK and the UK Online Measurement Company, people in the UK spend two hours and fifty-one minutes online on an average each day (Connelly, 2015). Several different kinds of leisure activities take place in the online environment. The use of social media websites, such as Facebook, Snapchat, Twitter or Instagram, has become an important activity of everyday life. Furthermore, 65 per cent of European Internet users shopped online in 2015 (Reinecke, 2016). The borders between different online activities are blurred, and retailers use the online environment as an important instrument of communication and distribution. Thus, the online environment provides excellent opportunities for retailers to develop distinctive strategies (Porter, 2001).

Currently, online retailing can be considered the fuel for growth in Europe and North America. Lately, the Centre for Retail Research has published a study on the online and offline retailing performance in Europe. In 2015, the online sales were at £156.67 billion with a growth rate of 18.6 per cent (Retailresearch.org, 2016). This trend is set to continue. In 2016, online retail sales are expected to generate £182.80 billion in Europe. This represents double-digit growth. The highest growth rate is expected in Spain (18.8 per cent) and Germany (18.3 per cent). The highest sales volumes will be reached in the UK (£60.04 billion) and Germany (£52.77 billion). The European online retail market share reached 8.4 per cent in 2015. The highest market shares have been reached in the UK (16.8 per cent) and Germany (13.5 per cent). This has affected traditional stores

profoundly. On an average, offline sales in Europe declined by 1.4 per cent in 2015. This has keenly affected the UK and German markets, which account for the highest shares of online sales in Europe. Thus, there has been a pronounced shift from bricks-and-mortar towards online retailing. Outside Europe one can observe the same trend in the US market, where in-store sales declined by 1.9 per cent in 2015 (Retailresearch.org, 2016).

THEORETICAL CONTEXT

Research into multichannel retailing embraces the concept of integration of the different channels operating within an organisation (Neslin et al., 2006). Channel integration initially meant that a retailer should provide a seamless customer experience between stores and online shops. It implied that customers should be able to easily switch channels during their interaction with the retailer (Goersch, 2002; Seck, 2013). However, important questions remain unanswered. It is still a topic of major interest for researchers and practitioners, whether a seamless customer experience automatically means full channel integration, or if it means that the more integrated it is, the better the customer experience. For retailers, the level of integration is a difficult managerial decision. They face various challenges since channels might vary according to their purpose, features, cost structure and competitors (Berry et al., 2010). Studies have investigated the optimal level of integration in certain areas. Related literature has explored several aspects of the retail-mix. In particular, a special focus has been reserved for the integration of assortment (Emrich, Paul, & Rudolph, 2015; Mantrala et al., 2009), pricing and promotions (Vogel & Paul, 2015; Wolk & Ebling, 2010), fulfilment (Agatz, Fleischmann, & Van Nunen, 2008; Lang & Bressolles, 2013; Wolk & Ebling, 2010; Xing, Grant, McKinnon, & Fernie, 2010), and web- and store design integration (Emrich & Verhoef, 2015). However, none of the aforementioned areas has been completely resolved yet. Quite the contrary, there are still several areas that merit further investigation (Verhoef, Kannan, & Inman, 2015).

Assortment Strategies Across Channels

As regards retailer assortment strategies, it is deemed necessary to overcome the complex requirement to offer an attractive and large assortment on the one hand side, but to avoid choice-difficulty on the other hand side (Mantrala et al., 2009). There is controversy in the literature around the degree of assortment integration in multichannel retailing. Some researchers argue that the assortment does not necessarily need to be integrated when the target customer of the two channels is different (Berry et al., 2010; Neslin & Shankar, 2009). This is not the case for multichannel customers, who switch retail channels during the purchasing process. However, other researchers argue that product consistency is crucial to provide a seamless shopping experience for the customer (Berman & Thelen, 2004). In practice, most of the multichannel retailers nowadays apply an asymmetrical assortment strategy, which means that they offer a larger assortment online than offline (Emrich et al., 2015). Emrich et al. (2015) investigated the impact of multichannel assortment integration on underlying assortment relations. They classified three different assortment relations. Either assortments are substitutive (for instance, when a retailer sells two different kinds of similar shoes), or complementary (as is the case with shoes and shoe crème), or independent (for example shoes and sun lotion). The researchers found out that in any of the three assortment structures no integration of assortment is detrimental. However, they argued that for a multichannel retailer with a substitutive assortment, the perceived variety is lower when the assortment strategy is asymmetrical because customers tend to despise the decreased channel choice and autonomy.

Pricing Strategies Across Channels

Regarding pricing and promotions, multichannel retailers often need to find a way out of a particular dilemma: generally, customers expect products online to be equally or even less expensive than their in-store equivalents (Zhang et al., 2010). However, at the same time, customers expect integrated channels with a consistent pricing strategy among channels (Seck, 2013). In this context, the underlying question is how multichannel retailers are able to overcome this dilemma without losing market share and unsatisfied customers. In practice, retailers mostly tend towards a partial integration of their pricing (Wolk & Ebling, 2010). They charge the same posted prices across their different channels, because they fear that different prices might lead to customer confusion

and resentment. However, at the same time, many retailers apply channel-specific price promotions or charge handling and shipping costs (Neslin et al., 2006).

Wolk and Ebling (2010) developed a conceptual framework to describe the factors which might influence a pricing strategy across channels: specifically, competition, offline reach, online reach, number of distribution channels, organisational size, product type, and brand power. They argued that the lower the level of competition in one segment, the higher the extent of price differentiation that occurs. Thus, market power has an impact on price differentiation. For Wolk and Ebling (2010), physical distance is a criterion that determines whether customers have easy access to a product or if they need to spend more to gain access. For multichannel retailers this means that if the retailer operates just a few stores and also sells products online, the retailer is able to operate both channels exclusively. As a consequence, this retailer is in better position in that he can apply price differentiation on- and offline. The increasing number of customers who buy online and furthermore use different channels to do so means customers have easy access to a retailer's overall offer. This means that multichannel retailers should offer the same prices across their various retail channels. Regarding the number of distribution channels, the two researchers argued that the customised operation of each channel means an increase in transaction costs and more effort required from the retailer. Consequently, the more channels a retailer operates, the less channel-based price differentiation he will apply. The size of company is therefore pivotal. Retailers who face lower costs when engaging in price differentiation will apply it more often. Normally, big companies can leverage strategic advantages such as the efficiency of the organisation, cheaper purchases or superior technologies. Thus, larger retailing companies will more be likely to apply channel-based price differentiation. For certain product types, customers prefer one channel over another. For instance, customers prefer to buy clothing in-store, since they want to try clothes on and physically see and touch the item. So if one channel is superior to the other, it is more likely that customers will accept channel-based price differentiation and pay a higher price for a preferred channel. Generally, branding decreases the customer's price sensitivity. Yet channel-based price differentiation might also lead to confusion, and may in turn decrease brand power (Wolk & Ebling, 2010).

Wolk and Ebling's (2010) conceptual framework is a valuable contribution to the debate on channel-based price differentiation. It is the first framework to conceptualise the different influencing factors considering customer (market), retailer and product characteristics. However, channel-based price differentiation has certain positive and negative impacts on customer satisfaction. It positively affects their perceptions of value and it increases relationship quality. Furthermore, it enhances repurchase intentions, but it also leads to perceptions of price unfairness and limits customer self-determination. This can negatively affect retention outcomes (Vogel & Paul, 2015). The extent to which the aforementioned affect the final choice of shopping location remains questionable, as does the long-term relationship that is established with the retailer. One possible pricing strategy for multichannel retailers, which embraces both- a high perception of value and price fairness, is 'self-matching pricing' (Kireyev, Kumar, & Ofek, 2015). Here, the multichannel retailer can set different prices across channels, but he offers the lowest price to the customer when he can supply evidence. Thus, self-matching policies by design offer retailers the flexibility of setting different prices across channels, while affording consumers the possibility of a consistent experience, presumably in line with the omni-channel philosophy (Kireyev et al., 2015).

Price promotions at multichannel retailers have several within- and across- channel implications. Offline price promotions can reduce category sales online during the promotion period. Furthermore, online promotions can reduce category sales offline during the promotion period. Negative cross-channel impacts are stronger for loyal customers than for opportunists; and the impact of online promotions on offline sales within the promoted category is higher than it would be if these variables were reversed (Breugelmans & Campo, 2016).

One can conclude that the successful management of pricing and promotions is a complex field in multichannel retailing. It is deemed necessary to consider effects within and across channels. The majority of studies about pricing and promotion strategies in multichannel retailing settings in any case suggest a consistent pricing strategy for all channels (Berman & Thelen, 2004; Vogel & Paul, 2015; Wolk & Ebling, 2010).

Fulfilment Strategies Across Channels

Regarding fulfilment, a coherent multichannel strategy should concern both the marketing mix and operations management (Agatz et al., 2008). In this respect fulfilment is an important component of a multichannel retailer's operations strategy. According to the literature, multichannel e-fulfilment can be considered to fulfil online or in-store orders, including warehousing, picking and order preparation, distribution, purchasing, delivery and returns (Agatz et al., 2008; Lang & Bressolles, 2013). For multichannel customers, four dimensions of fulfilment can be considered as predominantly important: timeliness, availability, condition and return (Xing et al., 2010). Timeliness refers to several aspects, such as speed of delivery, choice of delivery date, or delivery within a certain time slot. Availability refers to the confirmation of availability, order tracking, or waiting time. Condition refers to order accuracy, order completeness, or order damage. Return refers to return policies, such as ease of return and return channel options, the promptness of collection and of replacement (Lang & Bressolles, 2013). For multichannel retailers this means that their supply chain management needs to be adapted to these specific customer needs. This has several implications: (1) an online channel provides not only a physical product, but also several related services, most notably delivery. The delivery service may range from making the product available for pick-up to offering a time-specific home delivery. The management of this service component of e-fulfilment gives rise to novel planning issues. (2) The flexibility of a multichannel retailer with respect to order promising and pricing makes it necessary to imply an appropriate strategy. (3) The integration of different channels raises issues for inventory deployment, since different channels may require varied service levels (Agatz et al., 2008). (4) E-fulfilment requirements are different across various product categories (Hu, Kumar, & Sumit, 2014).

Web and Store Design Integration

Web and store design integration has an important impact for multichannel retailers. Web and store design can be considered as counterparts that fulfil a similar ultimate function. Web design refers 'to the richness of the representation of the website's environment, linked to its formal characteristics such as graphics, colours, images, animates, etc. These elements contribute to the look, feel, and atmosphere of the website' (Bressolles, Durrieu, & Senecal, 2014, p. 890). Thus, web design is the visual appearance and audible application of the site. Store design refers to aspects such as modern-looking in-store equipment and fixtures. Furthermore it implies that physical facilities are visually appealing (Dabholkar, Thorpe, & Rentz, 1996).

Multichannel retailers need to decide whether or not to adopt a prototypical (with channel-specific attributes) or a homogeneous design of web and store design (Emrich & Verhoef, 2015). Emrich and Verhoef (2015) suggest that a homogenous design creates positive effects for patronage intentions and behaviour, when a customer generally shows a high store-orientation. If a customer exhibits a high web-orientation, these effects are not evident (Emrich & Verhoef, 2015). Thus, multichannel retailers can use a homogeneous design to increase their appeal to store-oriented customers in both on- and offline environments.

CONCLUSION AND RECOMMENDATIONS

This chapter sets out a number of managerial implications. First, managers of multichannel retailing companies need to find the optimal level of channel integration for their organisation. In so doing, they are able to fully leverage the competitive advantage of both channels. Regarding assortment, the product range structure relation affects the impact of assortment integration (Emrich & Verhoef, 2015): For substitutive assortments – which applies to most fashion retailers – the current paper suggests that managers should set up a symmetrical assortment strategy, since the variety perception is higher when assortments are symmetrical.

In terms of prices and promotions, customers expect online products to be equally or even less expensive than their in-store equivalents (Zhang et al., 2010), but at the same time, customers expect integrated channels to have a consistent pricing strategy among channels (Seck, 2013). Therefore, this paper suggests three different pricing strategies: (1) Retailers can charge the same posted prices online and offline, but additionally charge handling and shipping costs; (2) Retailers can apply 'self-matching pricing', which offers

retailers the flexibility of setting different prices across channels, while affording customers the possibility of a consistent experience; (3) Retailers can perform single channel promotions to temporarily support one channel. This leads to a short-term increase of sales in the channel that is promoted, but does not carry any negative long-term effects. However, managers of multichannel retailers need to consider effects within and across channels when setting up a promotion strategy. Furthermore, multichannel retailers need to adapt their supply chain management processes to the specific needs of multichannel customers (Agatz et al., 2008). In this context, the current paper suggests four dimensions of fulfilment as predominantly important: timeliness, availability, condition and return of items. Regarding web and store design, retail managers who aim to increase their channel synergies should adopt a homogeneous design in order to specifically leverage the store-oriented customer segment (Emrich & Verhoef, 2015).

REFERENCES

- Agatz, N., Fleischmann, M., & Van Nunen, J. (2008). E-fulfillment and multichannel distribution- a review. *European Journal of Operational Research*, 187, 339-356.
- Berman, B., & Thelen, S. (2004). A guide to developing and managing a well-integrated multi-channel retail strategy. *International Journal of Retail & Distribution Management*, 32(3), 147-156.
- Berry, L., Bolton, R., Bridges, C., Meyer, J., Parasuraman, A., & Seiders, K. (2010). Opportunities for innovation in the delivery of interactive retail services. *Journal of Interactive Marketing*, 24(2), 155-167.
- Bressolles, G., Durrieu, F., & Senecal, S. (2014). A consumer typology based on e-service quality and e-satisfaction. *Journal of Retailing and Consumer Services*, 21, 889-896.
- Breugelmans, E., & Campo, K. (2016). Cross-channel effects of price promotions: an empirical analysis of the multi-channel grocery retail sector. *Journal of Retailing*, 92(3), 333-351.
- Connelly, T. (2015). 2 hours and 51 mins- this is the 'definitive' amount of time Brits spend online per day, claim the IAB and UKOM. Retrieved from <http://www.thedrum.com/news/2015/09/01/2-hours-and-51-mins-definitive-amount-time-brits-spend-online-day-claim-iab-and-ukom>
- Dabholkar, P., Thorpe, D., & Rentz, J. (1996). A measure of service quality for retail stores: scale development and validation. *Journal of the Academy of Marketing Science*, 24(1), 3-16.
- Emrich, O. (2011). *Cross Channel Management- Kompetenzen, Instrumente und Erfolgspotenziale*. (Dissertation), University St. Gallen, St. Gallen.
- Emrich, O., Paul, M., & Rudolph, T. (2015). Shopping benefits of multichannel assortment integration and the moderating role of retailer type. *Journal of Retailing*, 91(2), 326-342.
- Emrich, O., & Verhoef, C. P. (2015). The impact of a homogenous versus a prototypical web design on online retail patronage for multichannel providers. *International Journal of Research in Marketing*, 32, 363-374.
- Goersch, D. (2002). *Multi-Channel integration and its implications for retail web sites*. Paper presented at the The 10th European Conference on Information Systems, Gdansk.
- Hu, M., Kumar, R., & Sumit, C. (2014). Best practices in strategic multichannel fulfillment. *Ivey Business Journal*, Mar/Apr 2014, 1-6.
- Kireyev, P., Kumar, V., & Ofek, E. (2015). *Match your own price? Self-matching as a multichannel retailer's pricing strategy*. Harvard Business Review. Watertown.

- Lang, G., & Bressolles, G. (2013). Economic performance and customer expectation in e-fulfillment systems: a multichannel retailer perspective. *Supply Chain Forum*, 14(1), 16-27.
- Mantrala, M., Levy, M., Kahn, B., Fox, E., Gaidarev, P., Dankworth, B., & Shah, D. (2009). Why is assortment planning so difficult for retailers? A framework and research agenda. *Journal of Retailing*, 85(1), 71-83.
- Neslin, S., Grewal, D., Leghorn, R., Shankar, V., Teerlin, M., Thomas, J., & Verhoef, P. (2006). Challenges and opportunities in multichannel customer management. *Journal of Service Research*, 9(2), 95-112.
- Neslin, S., & Shankar, V. (2009). Key issues in multichannel customer management: current knowledge and future directions. *Journal of Interactive Marketing*, 23, 70-82.
- Porter, M. (2001). Strategy and the Internet. *Harvard Business Review*, March/April 2001, 63-78.
- Reinecke, P. (2016). E-commerce statistics for individuals. Retrieved from http://ec.europa.eu/eurostat/statistics-explained/index.php/E-commerce_statistics_for_individuals
- Retailresearch.org. (2016). Online retailing: Britain, Europe, US and Canada 2016. Retrieved from <http://www.retailresearch.org/onlinereetailing.php>
- Seck, A. (2013). The issue of multichannel integration, a key challenge for service firms in a context of multichannel services distribution. *International Business Research*, 6(2), 160-169.
- Statista.com. (2016). Percentage of households with Internet access worldwide in 2016, by region. Retrieved from <http://www.statista.com/statistics/249830/households-with-internet-access-worldwide-by-region/>
- Verhoef, P., Kannan, P. K., & Inman, J. J. (2015). From multi-channel retailing to omni-channel retailing: introduction to the special issue on multi-channel retailing. *Journal of Retailing*, 91(2), 174-181.
- Vogel, J., & Paul, M. (2015). One firm, one product, two prices: channel-based price differentiation and customer retention. *Journal of Retailing and Consumer Services*, 27, 126-139.
- Wolk, A., & Ebling, C. (2010). Multichannel price differentiation: an empirical investigation of existence and causes. *International Journal of Research in Marketing*, 27, 142-150.
- Xing, Y., Grant, D., McKinnon, A., & Fernie, J. (2010). Physical distribution service quality in online retailing. *International Journal of Physical Distribution and Logistics Management*, 40(5), 415-432.
- Zhang, J., Farris, P., Irvin, J., Kushwaha, T., Steenburgh, T., & Weitz, B. (2010). Crafting integrated multichannel retailing strategies. *Journal of Interactive Marketing*, 24, 168-180.

WORKPLACE STRATEGIES TO INCREASE ENVIRONMENTAL AWARENESS TO REDUCE GLOBAL WARMING EFFECTS

Sandra Perks and Jodé May
Nelson Mandela University, South Africa

ABSTRACT

To reduce global warming requires organizational commitment as the way in which leaders approach it, will affect the outcome thereof. The primary research objective of this paper is to determine how South African organizations increase their knowledge on global warming reduction, and create awareness of it in the workplace, and beyond. A qualitative research approach was followed. Data was collected from 13 South African sustainability leaders, by means of face-to-face, email and/or telephonic interviews, using a semi-structured interview schedule. Data was analyzed using content analysis and the constant comparison method. South African organizations extend their knowledge on global warming reduction best practices by attending local conferences and they utilize many communication media to create awareness amongst employees and the public of their global warming reduction efforts. Employees were encouraged to also apply global warming reduction strategies in their personal life.

Keywords: Communication, Environmental Awareness, Global Warming, Knowledge Creation, Strategies.

INTRODUCTION AND RESEARCH GAP

A key global challenge in the 21st century is how to address climate change and reduce GHG (Green House Gas) emissions. White (2011) notes that earth has warmed significantly since the mid-twentieth century due to an increase in greenhouse gases that trap heat on the earth. The ability to address the risks related to global warming can lead to significant business value as environmental stewardship improves and results in differentiated products, more effective operations and a more sustainable world. In sustainable organizations, managers incorporate environmental concerns into every strategic decision, revise policies and procedures to support sustainability efforts and measure their progress toward sustainability goals (Daft, 2008).

In South Africa, listed organizations on the Johannesburg Stock Exchange need to adhere to the King IV report and are legally required to report on environmental aspects (Institute of Directors in Southern Africa, 2017). The King IV report in South Africa identifies social responsibility (appreciation of the social, environmental and economic communities) as one of the seven primary characteristics of good governance (Hough, Thompson, Strickland & Gamble, 2008). South Africa has made significant progress with environmental management by implementing laws and strategies that focus on sustainable development and environmental preservation (Engel 2008). Unfortunately, most organizations still do not recognize the need to pay attention to environmental issues. This view may be contributed to assuming that incorporating “green” into their business strategy would cost money (Van der Zee, 2008, p. 6).

Incorporating environmental strategies requires change and change is a complex process. Higgs and Rowland (2005, p. 121) confirmed that up to 70 percent of change initiatives fail. Striking the balance between managing a successful organization and paying attention to environmental issues requires excellent leadership

(Chen, 2011, p. 384). The first step in implementing changes is to make employees aware of the intended changes. This led to the research in question, which is: *Do South African organizations have adequate environmental awareness strategies to reduce global warming?*

GLOBAL WARMING AND ITS EFFECTS

Global warming is the increase of the average temperature on earth due to human GHG emissions (Kunzemann & Lindinger, 2010); in other words, global warming is the cause and climate change is the effect. The effects of climate change along with pollution and the depletion of non-renewable natural resources has given rise to environmental awareness (Douglas, 2006, p. 458). Because of the effects of global warming and increase in environmental regulatory pressures, organizations both large and small together with government, must proactively move towards green management (Lee, 2009, p. 1107). This proactive approach is evident in the establishment of the Kyoto Protocol, the first agreement between nations to mandate country-by-country reductions in GHG emissions, at the 1992 earth summit meeting. Mitigation consists of reducing emissions of GHGs at the beginning of the chain, while adaptation means responding to economic damages of climate change at the end of the chain (Greenhouse Policy Coalition, 2007). The Kyoto Protocol can be viewed as a tool for environmental sustainability as it puts into place certain controls and regulations to allow countries to control their environmental impact, and can provide several opportunities and benefits and create awareness and collaboration between organizations to assist in the reduction of global warming activities (Vlachou & Konstantinidis, 2010, p. 32). The South African economy, which is predominantly driven by the mineral extraction and processing. Bond, Dada and Erion (2007, p. 8) observe that South Africa is one of the largest producers of GHG emissions in the world, and that 90 per cent of the energy it generates comes from the combustion of coal which contains more than 1 percent Sulphur and more than 30 percent ash.

WORKPLACE ENVIRONMENTAL STRATEGIES

The awareness of the depletion and degradation of natural resources is growing. The environmental sustainability movement has awakened nations, organizations, and individuals to the necessity of environmental protection for the benefit of generations to come (Nguyen & Slater, 2010, p. 5). The current economic climate has contributed to organizations being more open-minded about being environmentally friendly, especially with regard to cost saving initiatives such as recycling; using energy-saving devices or alternative energy sources such as solar or wind-generated power; water re-use; and efficient use of raw materials, especially scarce resources or choosing alternative sources such as bio-fuels (Dimmer, 2008). Organizations can demonstrate ecologically sustainable leadership by developing an awareness of how an organization interacts, not just with the community, but with the world, by engaging in global warming reduction effects by “greening” their buildings, transport reduction, pollution reduction, and planting trees (Harrison, 2010; General review, 2011, p. 6).

The working environment is driven by the power of information technology, market pressures, changing demographics and employee expectations (Saurin, Ratcliffe & Puybaraud, 2008, pp. 246-247). This suggests that leaders who wish to effect workplace changes must create a working environment that focus on people, technology and strategy. Changes in people’s daily behavior are crucial to reduce the effects of global warming, but awareness of the problem is the first step and is dependent on effective leadership. The influence of effective leadership on individual, team and organizational performance is acknowledged (Muchiri, Cooksey, Di Milia & Walumbwa, 2011, p. 462). Communication skills and the ability to manage a diverse group of people are critical skills for creating awareness and leading in rapidly changing environments (Furst & Reeves, 2008). The interpersonal skills, political acumen and leaders who communicate openly, demonstrate integrity and trust, and encourage participation, should outperform those with a more traditional command-and-control style of leadership (Bennis & Goldsmith, 2003, p. 122).

RESEARCH DESIGN AND METHODOLOGY

The qualitative paradigm was utilized, with an emphasis on acquiring quality, in-depth information about how participating organizations increase their knowledgeable on global warming reduction and raise awareness to effect it. A small sample of 13 participants (environmental sustainability leaders, on a senior environmental management level, actively involved in workplace environmental sustainability) was interviewed. Different business and employment sectors, in both the private and public sectors, in three provinces (Gauteng, the Western Cape and the Eastern Cape), in South Africa, were surveyed to increase generalizability of the findings. Some participants were identified in an internet search and through snowball sampling, where the first two participants were known by the researchers. Where possible, participants were interviewed face-to-face, or else contacted telephonically or via email. Data was collected utilizing an open-ended interview schedule on how the organizations increase their knowledge about global warming reduction and raise environmental awareness in their workplace and beyond, as well as their biographical data, and those of their place of employment. After data collection, the data was retyped using the exact words and language. Follow-up interviews were via e-mail or telephonically to probe for deeper meaning, and/or to further acquire and confirm information obtained in the first interview. Data was analyzed using conventional content analysis (thematic analysis) and constant comparative analysis. White and Marsh (2003, p. 35) explain that the qualitative nature of content analysis focuses on the meaning of content in the development stages of research to determine the frequency of the phenomena of interest. The researchers used an adaptive version of Tesch's eight-step model to analyze the data by (De Vos, Strydom, Fuche & Delpport, 2002, pp. 340-341):

- Reading through transcripts to *obtain a sense of the whole interview and understand the information*;
- *Allocating codes to themes identified in the relevant sections of text within transcripts* namely, type of awareness (public, employee and customer); and
- *Arranging similar topics within themes into subthemes*, such as, using intranet for employee awareness.

The researchers ensured that the themes and sub-themes were mutually exclusive. For the purpose of this paper, the empirical findings were presented in a thematic descriptive summary. During the data collection, the researchers went back to participants to enquire for further information (constant comparative analysis) to aid the generation of a theory that is integrated, consistent, plausible and close to the data (Glaser, 2008). Three to four follow-up interviews were required with the 13 participants to explore all the differences together with similarities noted between the responses of all the participants. Data triangulation was also used by referring to information on the organization's websites to confirm information provided during the interviews, or through follow-up interviews.

For a qualitative study, the four issues of trustworthiness that demand attention are credibility, transferability, dependability, and confirmability (Collis & Hussey, 2003, p. 278). The position of the participants and some information obtained in the interviews could be confirmed on the website of the organization, ensuring *credibility*. Comparisons across cases that yield similar findings also increase *transferability*. The researchers attempted to ensure *dependability* by using multiple methods of data collection and analysis and by ensuring that all notes, emails, interview schedules, transcripts and memos were retained should an audit be required. To ensure *confirmability*, the researchers archived all collected data, so that it could be made available should the findings be challenged.

EMPIRICAL RESULTS

The passion of the participants was noted at the commencement of the interviews when all participants indicated that they are in some or other way personally involved in green issues at home and not just involved in their workplace in environmental sustainability efforts due to their positions. Two questions were asked namely a) how they obtain/increase their global warming reduction knowledge and b) how the organization creates awareness of global warming and its effects. From the content analysis, it was clear that participating organizations increase their knowledge on global warming and its workplace effects by attending global or local conferences. The participating organizations create both external (public and customer) and internal (employee) awareness of global warming and its effects. Participants included a mining company, an advice and audit company, two global multi-national

retailers, one South African retailer, two manufacturers, two financial institutions, two educational institutions and two local government organizations.

Increasing Knowledge on Global Warming and its Effects

Only the general manager of the mining organization, as an invited guest speaker to share his experience, attends global conferences on global warming, in spite of many of the participating organizations having a global presence. All public local government and educational institutions, and only five of the nine private organizations send employees to attend local conferences to increase their knowledge on how to reduce global warming. Two multinational private sector retailers receive information from their global counterparts who attend global conferences. One financial institution does not attend conferences on global warming and its effects. The local conference attendees are either employee teams or one manager, normally the sustainability manager or head of operations or infrastructure. Employees from different departments may also be sent to obtain knowledge related to their specific field of employment such as, for green building knowledge, or workplace health and safety issues. Conferences attended include Conference of Parties 17, Resilient Cities, Africa Climate, and Alternative Energy and Low Carbon Development conferences. It must be noted that listed South African organizations on the Johannesburg Stock Exchange are legally required to report on environmental aspects (Institute of Directors in Southern Africa, 2017) and this may be the reason why many organizations are keen to further their knowledge on global warming and its effects. Table 1 provides a summary of the themes and sub-themes identified of how the participating organizations go about creating awareness of global warming and its effects, followed by a discussion within the main themes.

Table 1: Themes and sub-themes of creating global warming awareness

Themes and subthemes	
Public awareness tools	Employee awareness tools
Mass media	Intranet
Social media	E-mails
Organizational website	Face-to-face training workshops
E-mail	Online training
Green campaigns	Partnerships to create think tank
Customer awareness tools	Employee wellness programmes
Product labelling	Green campaigns

Only one retailer at store level creates awareness of global warming and its effects amongst their customers through their product labelling.

Public Awareness

The participating organizations make the public aware of their global warming reduction strategies to combat climate change through mass media campaigns on national television, radio, newspapers, magazines, and digital channels. The focus of the public awareness in mass media is on disseminating research results, partnership with local school during green campus week, sustainability vision and strategy, major sustainability innovation announcements e.g. investment in a new factory with state-of-the-art equipment, education campaigns at schools and go green campaigns. Twitter, as a social media tool, is utilized to comment on climate-smart towns and electricity savings. In addition, some organizations use information pamphlets and posters on going green. Websites are used by the participating organizations to publish an annual sustainability report, carbon disclosure report, education campaigns, and Go Green campaigns. Participants share in newspaper advertisements their participation in global warming events such as, the international climate change forum, Earth Week, announcing 45 manufacturing zero

waste sites, Earth hour and COP17 linked to carbon and energy reduction, as well as green campus initiatives. The advice and audit institution merely advertise in newspapers their consulting services to organizations on the implementation of global warming reduction strategies, while one manufacturer makes their beneficiaries and potential beneficiaries aware of global warming through email communication.

Employee Awareness

Eight of the 13 participants indicate that their workplace uses intermittent intranet communication to inform employees about global warming and its effects (climate change) via written talk publications, a staff magazine and newsletters. Information is shared about success stories, carbon reporting, key performance areas, workplace waste management and water- and energy-saving programmes, green initiatives, announcing major upcoming conference events, and organised employee events on sustainability and environmental responsibility. Reminder emails are sent annually to employees to remind them about the retailer's sustainability vision and about the importance of their responsibilities toward the environment, as per their global communication guidelines. Both financial institutions encourage employees to personally implement small daily changes to reduce global warming through newsflashes and how to save electricity and use water wisely. Two retailers conduct conventional training workshops on amongst others, workplace energy usage, saving and reduction to make employees aware of global warming and its effects, while the mining company has educational media teaching employees how to be more energy-efficient. One educational institution conducts annual face-to-face contact information sessions with employees on global warming and its effects. One financial institution trains employees how to use an Internet tool to calculate their personal carbon footprint, while one manufacturer offers online learning on carbon footprint reduction and classroom-based training on identifying environmental threats, chemical sustainable management and waste separation. Presentations, workshops, a staff magazine and newsletters on the portal are also used to make employees aware of global warming and its consequences. The educational institutions have implemented a green campus initiative and a green campus awareness week, respectively. In addition, one educational institution has a pledge wall, where students pledge with "hand prints" their involvement in making others aware of the effects of global warming and energy conservation. The other education institution makes their technical team, which includes maintenance, aware of how they influence the environment through for example, the paint they use, and are encouraged to make choices, which are least harmful to the environment. One manufacturer gives each employee on Arbour Day each year a tree to plant and some of these trees are then planted in the communities they reside, to use the leaves for medicine. Another manufacturer has an employee wellness programme, which is aligned with the Department of Labour's monthly programme. One local government institution partnered with a local university to establish a climate change think tank on issues such as the influence of rising sea levels and coastal risks, how to ensure energy savings and energy efficiency, emissions profiling, encouraging the use of renewable sources of energy and non-motorised transport, and spatial planning for the development of urban areas. The other local government institution only makes employees at director's level aware of global warming and the consequences thereof.

DISCUSSION

The empirical results revealed that the South African participants mostly increase their knowledge of environmental sustainability, in particular global warming, by attending local conferences so as to better equip them for the challenge of environmental sustainability or, if having an opportunity, by attending a global conference. Leadership is crucial in driving global warming reduction in the workplace. Participants in this study view their work roles as influential in driving global warming reduction initiatives due to the positions they hold in their organizations. This may also be the reason why the local government and education institutions favor conducting green campaigns. In a study completed by Tamkin (2012, p. 94), it was suggested that the three elements that make a leader outstanding are systemic thinking, viewing people as their only route to excellence, and conceiving their role as having a positive influence on others. It is clear that most of the participating organizations are passionate about global warming reduction and raise awareness about how to do so both internally (employees) and externally (public and customers). The participating organizations utilize several mass media to raise public awareness of their global warming reduction strategies and events planned. Organizations can demonstrate ecologically sustainable leadership by developing an awareness of how an organization interacts, not just with the community, but with the world as

stated in General review (2011, p. 6). Furthermore, nature, society, and business are interconnected in complex ways that should be understood by all decision-makers (Triologue, 2013) and this may be the reason why almost all participants, especially those in the private sector, publish their sustainability reports online. Global reporting, which allows organizations to voluntarily report on their sustainability impacts, was mentioned by some of the organizations. Organizations can obtain a sustainability reporting framework, on reducing global warming effects, from the Global Reporting Initiative (GRI), a non-profit organization that works towards a sustainable global economy (Global reporting initiative, 2013). According to Wilburn and Wilburn (2013, p. 65), the GRI's sustainability reporting framework enables all organizations to measure and report their environmental sustainability performance and by doing so, increases the trust that stakeholders have in them, as it is conducted in a transparent manner demonstrating accountability. As environmental problems are real and urgent for our planet, South African organizations, along with their global counterparts, need to report on how they address environmental sustainability, with specific attention paid to how they can reduce global warming.

Internal communication channels used to raise employee awareness on global warming reduction strategies include the intranet, emails, online and face-to-face training workshops, green initiatives, collaborating with a local university to establish a think tank and through an employee wellness programme. The financial institutions and retailers do not appear to focus on raising environmental awareness publically but only do so internally, which may point to an effort to save costs. As should be part of their mandate, the education institutions use training (online and face-to-face) to raise environmental awareness internally amongst their employees. An interesting finding was that one manufacturing organization goes as far as raising environmental awareness through their employee wellness programme. The nature of their manufacturing activities could play a role as they are by law required to reduce air pollution. D'Amato, *et al.* (2015), has confirmed the effect of air pollution on employees' health such as mortality due to asthma and other respiratory diseases. The manufacturer may therefore be proactive to monitor their employees' health to negate potential lawsuits. However, private sector organizations hardly bother with raising external awareness, while all four public sector institutions (local government and educational) are actively engaged in making the public aware how to go about reducing global warming through printed and digital media and also utilize their intranet. Private sector organizations may regard public awareness as costly and thus are not willing to sacrifice short-term profits, especially considering the current economic climate. The empirical findings indicate that some organizations have training in place to inform employees of what they can do, not just within the organization, but also on a personal level, to reduce global warming and its effects. These organizations may also view this practical advice to reduce global warming in employees' homes as an effort in raising public awareness, as their employees may become role models for others in their communities.

BUSINESS IMPLEMENTATIONS

It is essential to create global warming awareness on a large scale to reduce climate change effects. It is the social responsibility of the workplace to be pro-active and share progress made to reduce global warming and its effects. Employees should be made aware of how to reduce global warming not just within the organization, but also in their personal lives and the communities in which they live. The public and most importantly customers should be informed and frequently reminded about global warming and its effects. Their efforts can be advertised on mass media to increase awareness. Top-level leaders should develop global warming reduction strategies, but environmental sustainability teams should be established by identifying passionate employees, who could act as workplace change agents and role models. They can increase awareness amongst other employees on how to become more environmentally friendly at work and at home. These change agents should be trained, send to global conferences to acquire new knowledge and then drive new-founded workplace strategies to reduce global warming. Employees must receive continuous communication, and reminded how to improve their global warming reduction efforts. Raising awareness on GHG emissions, energy saving and water preservation should continue to be pursued on a greater scale. GHG emission targets should be set and measured at specific intervals to ensure strategies are implemented. To show their commitment to global warming reduction, organizations should have a pledge wall where both employees and the general public can pledge their support, while visibly displayed affirmations throughout the workplace, can act as reminders. Employee incentives can be introduced to encourage them to become more aware of their actions. Competitions for global warming reduction activities can be introduced at trade exhibitions, with the best practical ideas winning a prize. These prizes should be product related to affect global

warming reduction. Organizations should also initiate special green days, and offer presentations and workshops to coincide with for example, Arbor Day and Earth Hour, to make known the benefits of global warming reduction.

REFERENCES

- Bennis, W. & Goldsmith, J. (2003). *Learning to Lead: A Workbook on Becoming a Leader*. 3rd Edition. New York: Basic Books.
- Bond, P., Dada, R. & Erion, E. (2007). *Introduction in Climate Change, Carbon Trading and Civil Society*. KwaZulu-Natal: University of KwaZulu-Natal Press.
- Chen, Y. (2011). Green Organizational Identity: Sources and Consequence. *Management Decision*, 49(3), 384-404.
- Collis, J. & Hussey, R. (2003). *Business Research*. 2nd Edition. New York: Palgrave: Macmillan
- Daft, R. (2008). *The New Era of Management*. 2nd Edition. United States: Thomson South-Western.
- D'Amato, G., Vitale, C., De Martino, A., Viegi, G., Lanza, M., Molino, A., Sanduzzi, A., Vatrella, A., Annesi-Maesano, I. & D'Amato, M. (2015). Effects on Asthma and Respiratory Allergy of Climate Change and Air Pollution. *Multidisciplinary Respiratory Medicine*, 10, 39.
- De Vos, A.S., Strydom, H., Fuche, C.B. & Delport, C.S.L. (2002). *Research at Grassroots for the Social Sciences and Human Service Professions*. 2nd Edition. Pretoria: Van Schaik Publishers.
- Dimmer, S. (2009). *Green issues for SMEs*. Available at: <http://www.newbusiness.co.uk/articles/utilities-advice/green-issues-smes>. (Accessed: 3 May 2017).
- Douglas, J. (2006). *Building Adaptations*. 2nd Edition. Oxford: Butterworth-Heinemann.
- Engel, D. (2008). *Three stages to a Greener Company*. Available at: <http://www.harmoniousliving.co.za>. (Accessed: 20 May 2017).
- Furst, S.A. & Reeves, M. (2008). Queens of the Hill: Creative Destruction and the Emergence of Executive Leadership of Women. *The Leadership Quarterly*, 19, 372-384.
- General review. (2011). Sustainable Leadership Leading Business, Industry and Local Government Towards a Sustainable Future. *Strategic Direction*, 27(2), 5-8.
- Glaser, B.G. (2008). *The constant comparative method of qualitative analysis*. Available at: <http://groundedtheoryreview.com/2008/11/29/the-constant-comparative-method-of-qualitative-analysis-1/>. (Accessed: 28 May 2017).
- Global reporting initiative. (2013). *What is GRI*. Available at: <https://www.globalreporting.org/information/about-gri/what-is-GRI/Pages/default.aspx>. (Accessed: 16 May 2017).
- Greenhouse Policy Coalition (2007). *Overview of the Kyoto Protocol*. Available at: http://www.gpcnz.co.nz/Site/The_Kyoto_Protocol_/Overview.aspx. (Accessed: 17 May 2017).
- Harrison, P. (2010). *Ways to Prevent Global Warming*. Available at: <http://www.benefits-of-recycling.com/waystopreventglobalwarming.html>. (Accessed: 23 May 2017).

Higgs, M. & Rowland, D. (2005). All Changes Great and Small: Exploring Approaches to Change and its Leadership. *Journal of Change Management*, 5(2), 121-152.

Hough, J. Thompson, A.A., Strickland, A.J. & Gamble, J.E. (2005). *Crafting and Executing Strategy*. South African Edition. Berkshire: McGraw- Hill.

Institute of Directors in Southern Africa. (2017). *King Code IV*. Available at: <http://www.iodsa.co.za/page/KingIVReport>. (Accessed: 17 May 2017).

Kunzemann, T. & Lindinger, K. (2010). *Climate Change: What is Global Warming?* Available at: <http://knowledge.allianz.com/climate/?119/global-warmingdefinition>. (Accessed: 20 May 2017).

Lee, K. (2009). Why and How to Adopt Green Management into Business Organizations? The Case Study of Korean SMEs in Manufacturing Industry. *Management Decision*, 47(7), 1101-1121.

Muchiri, M.K., Cooksey, R.W., Di Milia, L.W. & Walumbwa, F.O. (2011). Gender and Managerial Level Differences in Perceptions of Effective Leadership. *Leadership and Organization Development Journal*, 32(5), 462-492.

Nguyen, D.K & Slater, S.F. (2010). Hitting the Sustainability Sweet Spot: Having it All. *Journal of Business Strategy*, 31(3), 5-11.

Saurin, R., Ratcliffe, J. & Puybaraud, M. (2008). Tomorrow's Workplace: A Futures Approach Using Prospective Through Scenarios. *Journal of Corporate Real Estate*, 10(4), 243-261.

Tamkin, P. (2012). Leadership by Design. *Strategic Human Resource Review*, 11(2), 90-95.

Dialogue. (2013). *King III and integrated reporting*. Available: <http://www.dialogue.co.za/king-iii-and-integrated-reporting/>. (Accessed: 19 May 2017).

Van der Zee, B. (2008). *Green Business*. 1st Edition. London: Dorling Kindersley Limited.

Vlachou, A. & Konstantinidis, C. (2010). Climate Change: The Political Economy of Kyoto Flexible Mechanisms. *Review of Radical Political Economics*, 42(1), 32-49.

White, D. (2011). *What is global warming?* Available at: <http://usliberals.about.com/od/environmental-concerns/a/GlobalWarm1.htm>. (Accessed: 23 May 2017).

White, M.D. & Marsh, E.E. (2003). Content Analysis: A Flexible Methodology. *Library Trends*, 55(1), 22-45.

Wilburn, K & Wilburn, R. (2013). Using Global Reporting Initiative Indicators for CSR Programs. *Journal of Global Responsibility*, 4(1), 62-75.

ANALYSIS FROM AN INSTITUTIONAL PERSPECTIVE OF FIRM ALLIANCE PORTFOLIOS' IMPLICATIONS FOR INNOVATION: TWO CASES IN BRAZIL'S AUTOMOTIVE SECTOR

Clarice Breviglieri Porto
Federal University of Juiz de Fora – UFJF, Brazil

T. Diana L. van Aduard de Macedo-Soares
Pontifical Catholic University of Rio de Janeiro – PUC-Rio, Brazil

ABSTRACT

To contend with severe competition, multinationals in the automotive sector are adopting innovation oriented strategies that involve alliance portfolios to boost their innovation performance. This article presents the results of an analysis of the strategic implications for innovation performance of the alliance portfolios of two automakers in Brazil. The analysis was carried out using the case study method with the help of a framework that emphasized the institutional perspective. The results of the empirical research confirmed the appropriateness of the SNA-IF_Institutional Version framework as a tool to help executives from the automotive sector to analyze and manage their alliance portfolios with a view to leveraging their innovation performance, considering the country's institutional specificities.

Keywords: strategic alliance portfolios, innovation performance, automotive sector, institutional perspective.

INTRODUCTION

Faced with increasingly severe competition, multinationals in the automotive sector, especially in emerging countries such as Brazil, are adopting innovation-oriented strategies to find a differential and thus ensure their competitive edge. In the scope of these strategies, they are establishing portfolios of alliances to leverage their innovation performance (IP). However, these firms lack tools to identify which alliance portfolio (AP) characteristics have positive implications for innovation performance.

Based on an extensive literature review (Macedo-Soares, Turano, Esteves & Porto, 2016) and a documental investigation, in a previous stage of our research, we first formulated a series of propositions and drafted a conceptual model depicting the relationships between the variables contemplated in these propositions. Next, we developed a framework to help analyze the strategic implications of APs for innovation performance (Porto, 2016; Porto & Macedo-Soares, 2016). This framework, called SNA-IF_Institutional Version, emphasizes the importance of the institutional perspective, considering that multinationals are subject to significantly different institutional pressures. (It is a variation of Macedo-Soares's (2014; 2015) SNA Innovation Framework that was based on Macedo-Soares's (2011) Global SNA Framework).

Before applying this framework, focusing the automotive sector in Brazil, we carried out cluster analysis of this sector to identify the strategies of its main players, in keeping with Porter's (1986) typology. This enabled us to identify three strategic groups of firms: i) differentiation; ii) focus - differentiation; and iii) "stuck in the middle"

(Porto et al. 2016). After a deeper analysis of these firms' strategies, we identified those that were explicitly innovation-oriented.

With the help of the SNA-IF_Institutional Version we analyzed two firms with such strategies, respectively from groups i) and ii).

This article presents the results of this analysis in terms, both, of identifying the strategic implications of these firms' APs for IP and of contributing to the evolution and refinement of the abovementioned propositions and conceptual model. Preliminarily, in the next section we provide the definitions of our main concepts.

THEORETICAL REFERENCES

We defined innovation as the development and sale of new products/services as well as the development of new processes and organizational solutions (Oslo Manual, OECD, 2005), distinguishing between radical and incremental innovation. The definition of alliances was that of Gulati (1998), as voluntary arrangements between companies aiming at exchanging, sharing or co-developing products/technologies/services. Alliance portfolio was defined as an egocentric network (Knoke, 2001), or ego-net for short, in accordance with social network theory (Ahuja, 2000; Ozcan & Eisenhardt, 2009)), as the focal firm's network of direct links with partners, as well as between partners. As to the institutional perspective, we adopted the economic and sociological/organizational approaches. With respect to the former, we based ourselves on Williamson (1995) as the main proponent of transaction costs theory, emphasizing the governance of contractual relations. He argued that when contractual relations are complex, transaction costs increase, negatively affecting IP. In keeping with DiMaggio and Powell (1983), the sociological/organizational approach considers that organizations tend towards homogenization as a way of gaining legitimacy and social acceptance. They identified this as an isomorphism phenomenon that includes three processes: coercive, normative and mimetic.

Multinationals also seek legitimacy by adopting similar behavioral patterns (Suchman, 1995). However, as Meyer & Rowan (1977) note, legitimacy only has positive implications for IP when a balance is struck between internal and external legitimacy. Because of its impact on multinationals, another important institutional theory concept is institutional distance, i.e., the relative difference between two countries in terms of their cognitive, normative and regulatory aspects (Kostova, 1999; Kostova & Zaheer, 1999). Large institutional distances in the AP can mean higher transaction costs, increasing the complexity of the portfolio's governance structure, with negative implications for IP. Conversely, when institutional distance is small, AP governance becomes easier (Marinova; Child & Mrinov, 2012; Chan; Isobe & Makino, 2008; Dikova, 2009; Gaur & Lu, 2007). For more details regarding the theoretical basis of the SNA-IF_Institutional Version framework, see Macedo-Soares et al. (2016), Porto (2016) and Porto & Macedo-Soares (2016).

RESEARCH METHODS

For the identification of the strategic groups among 12 assemblers in the Brazilian automotive industry that have factories in the country and have accounted for over 90% of the market over the past five years, we performed a statistical analysis using the Z-score, Shapiro-Wilk test and factor analysis, followed by K-means cluster analysis, MANOVA and ANOVA (see Porto et al., 2016). As mentioned, this led to the selection of the two firms that were the subject of our case studies.

The case study method (Yin, 2010; Eisenhardt 1989), including data triangulation, was used for the strategic analyses of the two selected firms, henceforth referred to as GAMMA and DELTA, in the scope of which we applied the SNA-IP_Institutional Version framework. The latter included a strategic analysis method with 11 steps, reference lists of variables and indicators, and a figure to depict each firm's ego-net. Data to perform the 11 steps of the method were obtained from a survey with predominantly structured questionnaires and from relevant documents.

In GAMMA and DELTA, respectively, 12 and 7 employees, practically all involved in innovation and product/process development, participated in the survey.

RESULTS

Here we give priority to the results from applying the steps of the SNA-IF_ Institutional Version Framework, pertinent to the characteristics of the firms' APs that have significant implications for IP.

First, however, it is important to recall that in keeping with our selection criteria, both GAMMA and DELTA had explicitly innovation oriented strategies, although, respectively, with wide and narrow scopes, and formed APs with the objective of enhancing their IP.

GAMMA, a multinational firm with over 20 000 employees, has its own R & D unit, with more than a thousand engineers devoted to the development of new sustainable cars, engines and transmissions. It invested around US\$5 billion in the last five years in innovation projects. It was a pioneer in eliminating solvent emissions and all residues are recycled for reuse. It has a wide product scope, serving all types of customers with a diversity of models for each category of vehicle. It has the capacity to produce more than 600 000 vehicles per year. Its geographic scope is also wide, covering the whole country, with operations in other Latin American countries as well.

DELTA is also a leading multinational firm, albeit smaller, with two technological centers in Brazil that work together with other R & D centers abroad. It invested more than US\$1 billion between 2010 and 2015. Contrary to GAMMA, it has a narrow product scope, in the sense that it does not offer different models for each category of vehicle and mainly focuses on middle class customers. It has a production capacity of around 300 000 vehicles per year and 400,000 engines a year, including innovative flex-fuel engines (which can run on any blend of gasoline and ethanol, or either fuel alone). It also innovates to develop new more environmentally sustainable components.

Regarding their partners for innovation, as shown in Figure 1, in both firms alliances with suppliers predominate, followed by those with complementors and firms from their own group. Note that only DELTA has innovation alliances with competitors and new entrants.

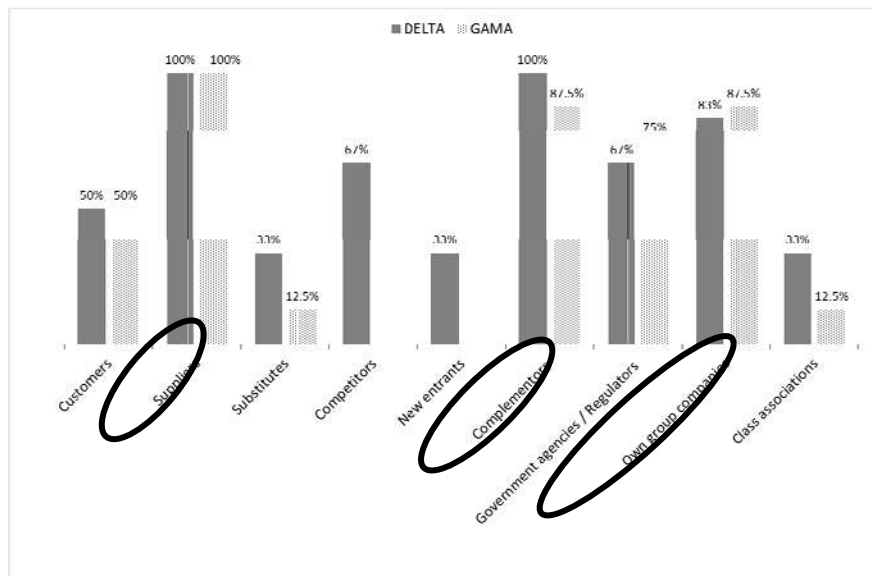

Figure 1: Main partners for innovation

In Charts 1 to 3, we list the types of alliances for the category of partners highlighted and their characteristics in terms of structure, composition and modality that have strategic implications for IP.

Company	GAMMA	DELTA
Type of Alliance	<ul style="list-style-type: none"> Joint venture Joint R&D Supply/co-fabrication agreement Development / Co-production Joint selling/marketing Licensing of patent or know-how Technology transfer R&D agreement Agreement for supply of other inputs/materials Service provision agreement 	<ul style="list-style-type: none"> Co-development/production Joint R&D Supply/co-fabrication agreement R&D agreement Joint venture Minority equity investment Industrial condominium Agreement for supply of other inputs/materials
Structure	<ul style="list-style-type: none"> - High density - Broad scope - Central position - Moderate diversity 	<ul style="list-style-type: none"> - High density - Broad scope - Central position - Moderate diversity - Global geographic scope
Composition	<p>Key Resources:</p> <ul style="list-style-type: none"> - Capability for innovation - Technological resources - Talents and skills - Information capital - Financial resources - Satisfactory volume - High complementarity - Difficult access - Rich content 	<p>Key Resources:</p> <ul style="list-style-type: none"> - Capability for innovation - Technological resources - Talents and skills - Financial resources - Physical resources - Social capital - Satisfactory volume - High complementarity - Difficult access - Rich content
Modality	<ul style="list-style-type: none"> - Medium connection <p>Nature:</p> <ul style="list-style-type: none"> - Collaborative - Exploration and exploitation 	<ul style="list-style-type: none"> - Medium connection <p>Nature:</p> <ul style="list-style-type: none"> - Collaborative - Exploration and exploitation

Chart 1: Types of alliances with suppliers of GAMMA and DELTA and their characteristics in terms of structure, composition and modality

With respect to the alliances with suppliers of GAMMA and DELTA, their great importance for the development of innovations, both incremental (exploitation) and radical (exploration) could be perceived. These alliances have a collaborative nature, meaning equilibrium of advantages exists between the partners. The strength of the connections (i.e., the degree of commitment, difficulty of rupture and contractual formalization between the company and its suppliers) is medium.

The types of alliances in function of intensity of the link are the strongest, involving joint R&D (Chart 4). This pattern is very characteristic of the sector (Pintec, 2011).

The alliances between automakers and suppliers have high density, broad scope, central position and moderate diversity. For performance in innovation, high density can be a weakness for the company, by increasing the redundancy of information and reducing the possibilities to generate innovation (Gilsing et al., 2008) or it can pose a threat if the company is trapped with other companies with undesirable resources (Gulati, Nohria & Zaheer, 2000). However, since the diversity is moderate, the geographic scope is global and the position of the companies in

relation to suppliers is central, this facilitates diversification of knowledge, minimizing the possible negative effects of high density.

Company	GAMMA	DELTA
Type of Alliance	Joint R&D Licensing of patent or know-how Technology transfer R&D agreement Service provision agreement	Joint R&D Licensing of patent or know-how Joint venture Service provision agreement Supply/co-fabrication agreement Development / Co-production Agreement for supply of other inputs/materials Service provision agreement Associations
Structure	<ul style="list-style-type: none"> - High density - Restricted scope - Intermediate position - Little diversity 	<ul style="list-style-type: none"> - High density - Broad scope - Central position - Little diversity - Global geographic scope
Composition	Key Resources: <ul style="list-style-type: none"> - Capability for innovation - Financial resources - Technological resources - Talents and skills - Physical resources - Satisfactory volume - High complementarity - Difficult access - Rich content 	Key Resources: <ul style="list-style-type: none"> - Capability for innovation - Financial resources - Technological resources - Satisfactory volume - High complementarity - Difficult access - Rich content
Modality	<ul style="list-style-type: none"> - Medium connection Nature: <ul style="list-style-type: none"> - Collaborative - Exploration and exploitation 	<ul style="list-style-type: none"> - Medium connection Nature: <ul style="list-style-type: none"> - Collaborative - Exploration and exploitation

Chart 2: Types of alliances with complementors of GAMMA and DELTA and their characteristics in terms of structure, composition and modality

The strategic alliances with complementors have a collaborative nature in which no undue advantage exists for either partner, constituting a win-win relationship (Chart 2). Through these alliances, the companies seek incremental innovations (exploitation) and radical innovations (exploration). The shared resources have rich content, high complementarity and satisfactory volume. The high diversity that causes homogeneous knowledge (Lazer & Friedman, 2007), derived from redundancy of information and little diversity existing in the AP of the companies does not favor superior innovative results.

GAMMA is in a peripheral position in relation to complementors and its scope is restricted. On the other hand, DELTA is central with broad scope, allowing it to have greater access to information, knowledge and key resources, favoring the innovative capability of DELTA slightly more than that of GAMMA.

Both companies have various alliances with complementors, such as universities and research institutes, related to joint activities in R&D, licensing of patents or service provision agreements (Chart 4). This result converges to those of other studies in the sector, such as Pintec (2011).

Company	GAMMA	DELTA
Type of Alliance	Joint venture Cross shareholding (cross licensing) Minority equity investment Joint R&D Supply/co-fabrication agreement Development / co-production Joint selling/marketing Licensing of patent or know-how Agreement for supply of other inputs/materials Service provision agreement	Minority equity investment Joint R&D Supply/co-fabrication agreement Development / co-production Joint selling/marketing Licensing of patent or know-how R&D agreement
Structure	<ul style="list-style-type: none"> - High density - Restricted scope - Intermediate position - Moderate diversity 	<ul style="list-style-type: none"> - High density - Broad scope - Peripheral position - Moderate diversity - Global geographic scope
Composition	Key Resources: <ul style="list-style-type: none"> - Capability for innovation - Financial resources - Technological resources - Talents and skills - Insufficient/satisfactory volume - Low complementarity - Easy access - Rich content 	Key Resources: <ul style="list-style-type: none"> - Capability for innovation - Financial resources - Technological resources - Satisfactory volume - High complementarity - Easy/hard access - Rich content
Modality	<ul style="list-style-type: none"> - Medium connection Nature: <ul style="list-style-type: none"> - Collaborative - Exploration 	<ul style="list-style-type: none"> - Medium connection Nature: <ul style="list-style-type: none"> - Collaborative - Exploration

Chart 3: Types of alliances with own group companies of GAMMA and DELTA and their characteristics in terms of structure, composition and modality

In relation to alliances with other companies of the group, both DELTA and GAMMA have similar behavior to that of their alliances with suppliers. These links are of a collaborative nature and have the purpose of developing new products and processes by means of alliances for exploration. The strength of the connections is medium (Chart 3).

The alliances between the automakers and other companies of their groups have high density, which can be a weakness by reducing access to new and different knowledge (Gilsing et al., 2008). GAMMA presents a restricted scope, which hampers the access to various types of information, impairing its innovation performance even more. On the other hand, the fact of having moderate diversity expands the possibilities for access to new knowledge and resources, which generates new opportunities to develop capabilities and increases the creation of value, favoring innovation (Jiang, Tao & Santoro, 2010).

The main types of alliances of GAMMA and DELTA with the other firms of their business groups are mainly oriented to joint R&D, co-fabrication, co-production, joint marketing and licensing of patents (Chart 4). These types of alliances are also identified in the study by Pintec (2011), that found that the main objective of cooperation in the relations between firms and other companies of the group are R&D and product testing.

With respect to alliances for innovation with governmental agencies/regulators, which are also important, although not to the extent of the other types mentioned above, in DELTA these can be classified as opportunistic, while in GAMMA they have a collaborative nature, seeking both incremental and radical innovations. The main resources that the companies seek from alliances with governmental agencies/regulators are information capital and financial resources. The connections are strong, which can make a good contribution to innovation when the resources are rich in content or the company is involved in an unproductive relationship. Since the alliances of DELTA have low density and peripheral position, they do not favor absorptive capacity, which is fundamental for good innovation performance (Gilsing et al., 2008). The small diversity in relations diminishes access to new knowledge, hindering innovation (Jiang, Tao & Santoro, 2010).

As observed, GAMMA does not have strategic alliances oriented to innovation with competitors and new entrants. On the other hand, DELTA maintains links with both these kinds of actors, of the opportunistic (win-lose) and exploration types, looking toward development of new products or processes. In relation to competitors, the main resource shared with DELTA is information capital, by means of alliances involving joint R&D, co-fabrication and co-production.

On the basis of these results, below we present the ego-nets of each of the two firms analyzed.

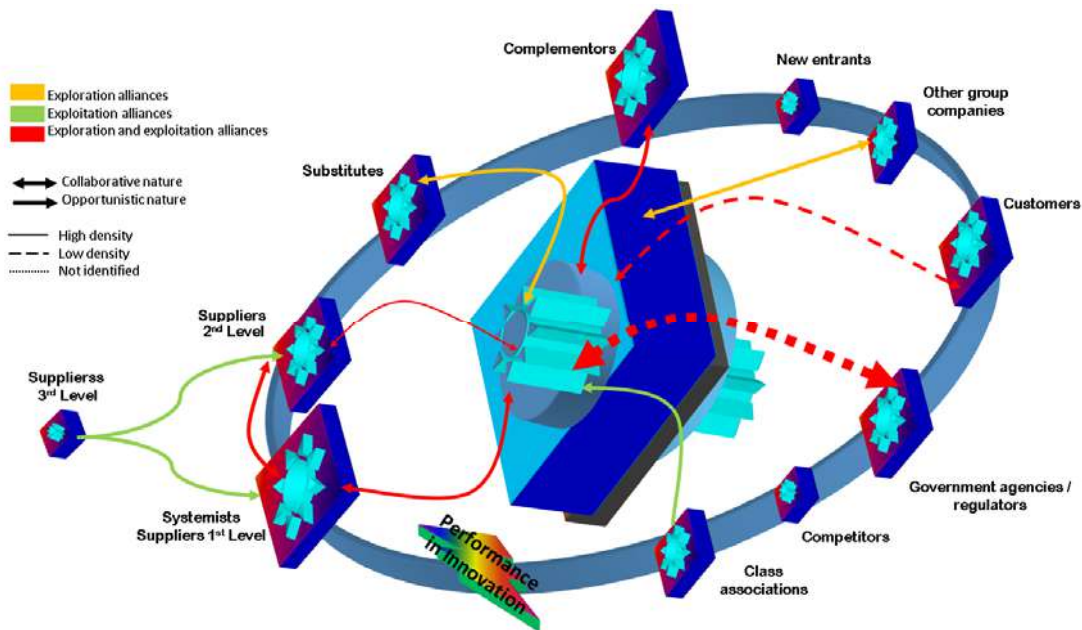

Figure 2: Ego-net of GAMMA

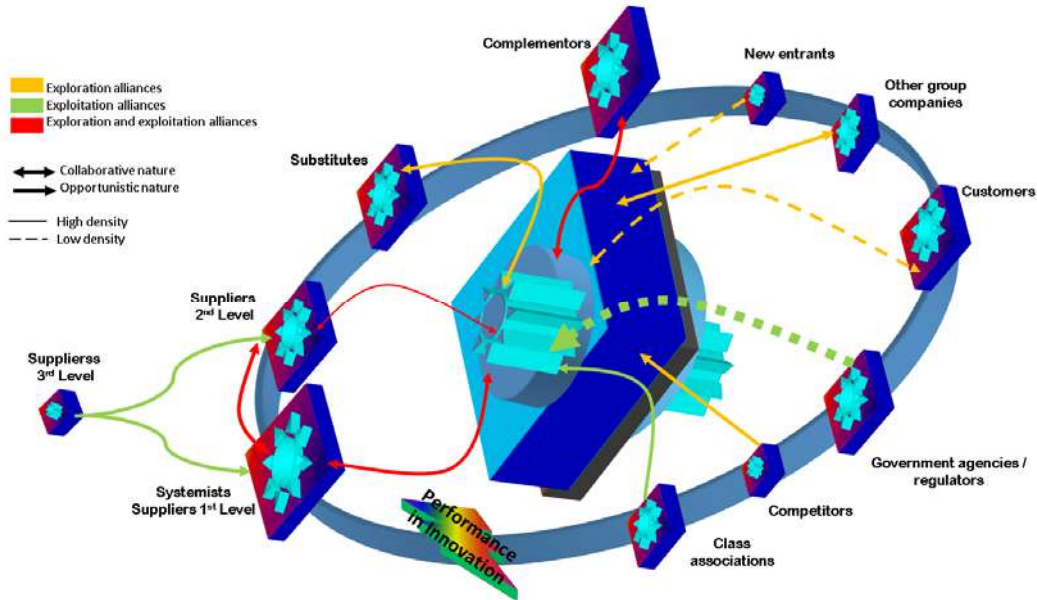

Figure 3: Ego-net of DELTA

In relation to the types of links, regarding intensity, between the focal company and strategic actors of its value network, Chart 4 presents the most representative alliances of firms in the automotive sector, accounting for more than 80% of the alliances formed between assemblers and the strategic actors in their value chain, based on the surveys conducted, involving DELTA and GAMMA. Although neither GAMMA nor DELTA have any modular consortium arrangement, the literature on the Brazilian automotive sector describes many cases of this type (Neto & Truzzi, 2009).

Type	Description
Joint venture	When a separate entity is created by the partners with a specific objective. Examples of this in the Brazilian automotive sector are Autolatina, between Volkswagen and Ford from 1986 to 1995, and the current joint venture PSA, formed by Peugeot and Citroen.
Minority equity investment	When one partner acquires a minority stake in another partner. This can be used to obtain access to technological knowledge.
Joint R&D	When partners agree to share research and development of products /processes/technologies. This is an intense practice, especially between assemblers and technology suppliers.
Modular consortium	The vehicle is assembled completely by the module suppliers (with installations within the assembler's plant). The assembler is responsible for the overall design and quality of the final product, as well as for procurement of components for the suppliers at the first and second level. The suppliers are strongly dependent on the assembler.
Agreement for supply – co-fabrication	When one or more companies supply materials to another, which in turn uses them to create a finished product or render a service, according to terms and conditions established in long-term contracts. This is also an intense practice in the automotive sector, mainly in the supply chain.
Co-development/production	When partners agree to develop or manufacture products together.
Industrial condominium	The final assembly of the vehicle is the responsibility of the assembler while the development and production of the modules is the responsibility of the suppliers. Suppliers have low dependence on the assembler, since they do not need to have a dedicated relationship with the assembler.

Licensing of patent or know-how	Allows a company that has exclusive technology or know-how to license its knowledge in return for an initial fee followed by royalties based on a percentage of future sales or some other formula.
Technology transfer	An arrangement where the partners share technology, either informally or through a formal contractual relationship, such as licensing or shared R&D.
R&D agreement	When partners formally agree to develop a specific product together.
Service provision agreement	When a partner renders services to another, such as technical support, training, assistance, etc.

Chart 4: Types of alliances for innovation

The results of the empirical analyses of GAMMA and DELTA also contributed to the evolution of the previously referred to propositions and conceptual model representing the variables considered in these propositions, developed in an earlier stage of the study based on an ample review of the pertinent literature (Porto & Macedo-Soares, 2016). Notably, these results led to the inclusion of a new proposition related to normative isomorphism and its positive impact on incremental innovation. On the other hand, the lack of data to support the effects of the institutional factors on reverse innovation meant we excluded this variable from the model. The propositions, after refinement, for the strategic analysis of multinationals oriented to innovation from the relational perspective are described and discussed next.

Many differences exist in terms of economics, culture, education and the way the business environment is regulated between emerging countries like Brazil and developed countries, where the parent companies of most of the Brazilian automakers are located. Many times these differences are also perceived between the assembler and its global partners, mainly the suppliers of systems and first-level suppliers, as well as other companies of the group.

To achieve competitive advantage, automakers need to adapt and overcome institutional differences (Landau, Karna & Sailer, 2016) that hinder transactions or increase their costs. The formal distance related to regulatory and normative aspects is affected by the level of government intervention by creating policies and rules that affect the automotive sector and the degree of protectionism established. Differences in judicial systems and enforcement of contracts and laws, the level of corruption in the political system, extent of bureaucracy and relative importance of relationships of trust in the professional setting all influence the operating costs of automakers and the level of investment made by the parent company (Globerman & Shapiro, 1999; Chan, Isobe & Makino, 2008). The cultural-cognitive institutional distance (i.e., the informal distance), involving culture and ideology, if large, can cause differences in management procedures. However, if this distance is small, it can reduce uncertainties and provide a framework for companies if formal institutions fail (North, 1990).

With respect to institutional distance, two propositions were included in the model.

P1: Large institutional distance between a multinational and host country or between the multinational and its AP partners causes an institutional duality that can have a negative effect on innovation performance.

P2: Small institutional distance, principally formal, between a multinational and host country or between the multinational and its AP partners can diminish differences in culture and beliefs, possibly having a positive effect on innovation performance.

The automakers inserted in an AP want to obtain, besides material resources, symbolic resources such as recognition and legitimacy. With the entry of new players or exit of existing ones and the alteration of the power resources of the actors, the institutional environment is affected (DiMaggio & Powel, 1983). Through the process of homogenization, characterized by isomorphism, companies try to obtain legitimacy and social acceptance. The isomorphism process therefore has impacts on innovation performance.

Coercive isomorphism, characterized by the pressures exerted on a company by others or by the government on firms, creates a type of dependence that can involve financial, material or technological resources or legal dependence (DiMaggio & Powel, 1983). By exerting coercive pressure, imposing conditions for operation and rules about other companies of the AP, the automaker inhibits radical innovations, because these require a free and creative environment to be developed. On the other hand, this coercive pressure by the automaker on the other

companies can lead to the development of improvements in their processes and products, characterizing incremental innovation. In turn, if the assembler faces coercive pressure within its AP, its innovative performance will suffer, since the dependence on or subordination to the cultural norms or expectations of other companies will compromise its freedom to create new innovations.

Another form of isomorphism is normative, characterized by professionalization (DiMaggio & Powel, 1983). By creating a similar body of knowledge by means of strong integration of the professionals of the automaker and its partner companies, such as by conducting joint training, and standardizing the methods and procedures to be adopted by the other firms, the automaker inhibits radical innovation, which needs new and different types of knowledge. However, during the empirical research, we found that recruitment of highly trained professionals, although this increases the similarity with the other partner companies, improves the competency and capability of the automaker's staff, contributing to the improvement of its processes and products.

Finally, mimetic isomorphism is defined as the adoption by the firm of procedures and structural models that have been tested and found successful by other firms (DiMaggio & Powel, 1983). For the purpose of reducing the uncertainties caused by ambiguous goals and uncertain technologies within the AP, the automaker will follow the model of other successful organizations, affecting its innovation performance. If the connections within the AP are composed of a balance between weak and strong ties, innovative companies will be able to imitate other companies that have certain similar aspects (Turner, 1991).

In regard to the isomorphism construct, we included five propositions.

P3: Coercive isomorphism of the focal company, by imposing its position on the AP partners, can inhibit radical innovation, i.e., exploration.

P4: Coercive isomorphism of the focal company, by imposing its position on the AP partners, can have a positive effect on incremental innovation, i.e., exploitation.

P5: Normative isomorphism arising from professionalization, by generating a common accepted wisdom among the AP partners, can limit openness to new thinking and hence innovation.

P6: Normative isomorphism from improvement of common knowledge among the AP partners can favor incremental innovation (exploitation).

P7: The mimetic isomorphism process, when the company seeks total imitation instead of just imitation of certain relevant aspects, has a negative influence on innovation performance.

Since the two automakers, both multinationals, are inserted in a particular institutional environment in their APs, they tend to seek legitimacy through similar behavior patterns (Suchman, 1995). Because they have various links with global partners simultaneously, they face different institutional pressures, requiring them to strike a balance between internal legitimacy, in their particular environments, and broader external legitimacy, involving the parent company and other partners (Hillman & Wan, 2005; Cheng & Yu, 2012). The legitimacy of an automaker can be considered the perception that its actions are desirable or appropriate within the environment of its AP, constructed in social form with norms, beliefs and values. A company's acceptance by its partners, consumers and society as a whole, confirming its legitimacy, helps determine its ability to obtain resources that affect its performance and stability, contributing indirectly to innovation (Rossoni & Machado-da-Silva, 2010).

Therefore, we also included a proposition related to the legitimacy construct.

P8: In seeking balance between internal and external legitimacy, a company increases its recognition, leading to an indirect improvement in its innovation performance.

Contractual relations and governance mechanisms protect companies from uncertainties of the institutional environment. According to Hertwing (2012), if these are used strategically, they can reduce the opportunism, moral hazard and uncertainty generated by lack of information, mainly in turbulent markets. They help increase cooperation between the automaker and the companies of its AP by improving communication. They also reduce transaction costs by giving greater transparency to negotiations and more information about the market.

However, highly complex contractual arrangements increase the possibility of conflicts, raising the cost of the governance structure (Jiang, Tao & Santoro, 2010). These high management costs can decline as the time of the relationship between the automaker and its partners increases (Ferrato et al., 2006), due to the increasing trust in relationships and more experience in interacting with partners (Sampson, 2005).

With respect to the contractual relations construct, we included two propositions as follows:

P9: The contractual relations existing in governance mechanisms, when highly complex, increase transaction costs, negatively influencing innovation.

P10: The contractual relations existing in governance mechanisms, when less complex, mainly due to trust in the relations, reduce transaction costs and positively influence innovation.

The organizational learning mechanisms that are directly related to firms' innovation performance are influenced by the institutional environment, which acts as a moderator both at the firm and industry levels (Chittoor, Aulakh & Ray, 2015). When the environment in the AP is less developed, less information and knowledge are shared and learning occurs by accumulation. Therefore, firms innovate by importing technology, requiring the same R&D investments to absorb and adapt to the imported technologies. On the other hand, if the institutional environment is more developed, favoring the development of new competencies and greater diffusion of knowledge, learning occurs by assimilation, i.e., an endogenous process of learning by doing. In this circumstance, innovation occurs by means of internationalization of the market for products.

The performance of the country where an automaker has productive activities affects its operating costs and its bottom line performance, as well as influencing the investments made by the parent company. (Globermann & Shapiro, 1999; Chan, Isobe & Makino, 2008). Underdeveloped institutional environments have a negative influence on the investments made by automakers and reduce their innovation performance.

With relation to the development of the institutional environment, we included the following three propositions.

P11: In developed institutional environments, organizational learning is based on assimilation, favoring innovation by means of internationalization.

P12: In underdeveloped institutional environments, organizational learning is based on accumulation, favoring innovation by means of importing technology.

P13: In underdeveloped institutional environments, the direct investments of a multinational are smaller, negatively affecting innovation performance.

In accordance with these 13 propositions, based on our empirical analyses of the automakers GAMMA and DELTA, the conceptual model evolved as represented in Figure 4.

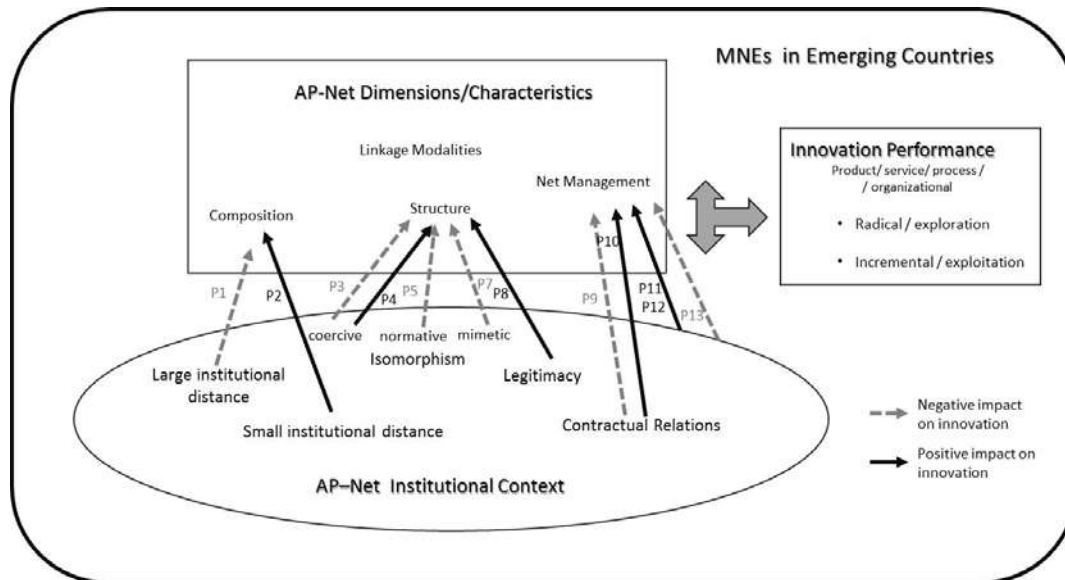

Figure 4: Conceptual Model

IMPLICATIONS, LIMITATIONS AND FUTURE RESEARCH

The strategic analysis of the automotive sector from a relational perspective and considering the institutional specificities, besides being important for assemblers and parts suppliers, has an impact on the country's entire economic and social system, in light of the great importance of the automotive sector's productive chain.

Innovation, mainly in relation to the development and introduction of new technologies for products and processes, is a key factor to improve performance and growth of companies in the highly competitive automotive sector. Both assemblers and their main strategic partners, the suppliers of systems or first-level suppliers, are multinationals with operations in widespread geographic regions, making them subject to different institutional pressures.

The results of this empirical study show that an analysis with the help of the "SNA-IF_Institutional Version" framework can reveal factors that traditional analysis does not identify. These factors, emerging from relational analysis considering innovation and its institutional requirements, have positive or negative implications for strategy oriented to innovation. The alliances in the AP of the two automakers studied act to minimize the threats from macroeconomic factors and strategic actors, as well as reduce weaknesses of the organizational factors, while at the same time enhancing opportunities and strengths. These effects can be felt in the various alliances formed, as demonstrated next.

The automotive sector as a whole, consisting of assemblers and parts suppliers, is aiming its innovations to develop more efficient engines (hence less polluting and more sustainable) and vehicles with more sophisticated on-board technology. The main highlights are flex-fuel, hybrid and/or electric vehicles that also provide greater safety and comfort. To attain this level of development it is necessary to form alliances between automakers and the other strategic actors. These alliances need to have resources with high complementarity and rich content. The sharing of resources, such as innovation and information capital, technological and physical resources, talents and skills are essential in the alliances existing in automakers' portfolios, so that the innovations occur with the proper intensity and at the correct moment, positively affecting their innovation performance.

Brazilian automakers have the opportunity to further develop the flex-fuel engine technology and increase the use of ethanol in the country, including as a fuel in hybrid cars. These efforts require alliances involving assemblers with systems suppliers and other strategic actors. In their alliances with suppliers, complementors and

own-group companies, automakers are developing new materials and products that are less polluting, more sustainable and also more economically feasible. Through these alliances, the impact of inputs on costs and the dearth of substitute products, which pose real threats, are reduced.

The various alliances established are subject to different institutional pressures because of the multinational scope that characterizes the automotive industry. These need to be minimized so as not to have a negative impact on the firm's innovation performance. By applying the proposed framework, managers can analyze how the similarities existing among the companies of the AP can accelerate incremental innovation and help increase the firm's knowledge. This common knowledge inhibits radical innovation by not encouraging novelty, but the increase of qualifications can contribute indirectly to the development of incremental innovations. Though the proposed framework, automakers can identify with which suppliers or other partners the institutional distances are smallest, allowing the strengthening of these alliances.

By establishing linkages with high density, automakers can improve their innovation performance due to the greater redundancy of information generated and lower risk of being linked to firms with unsatisfactory resources. Another feature is to enable managers to assess the existence of opportunism, uncertainties generated by the lack of information and absence of supply alternatives, all of which can increase transaction costs and negatively affect innovation.

The government's influence in the sector is very strong, through policies that affect the exchange rate, tax regime for the sector, interest rates, availability of financing (both for capital expenditures by firms and purchases by consumers), and rules on entry of new players. Through strong links with governmental agencies and regulators and the volume of transactions with these entities, automakers can identify the coercive pressures that exist, allowing them to minimize the threats from macroeconomic and political factors by using information capital, increasing the financial resources that can be targeted at improving their innovation performance.

In summary, the application of the "SNA-IF Institutional Version" framework proposed here can allow managers to analyze how knowledge and competencies are shared within the alliance portfolio. The main limitations of this study were the difficulty of establishing contacts with key people of the automakers in Brazil and the shortage of data to measure the performance of innovation activities. A suggestion for future research would be to conduct a specific study applying the "SNA-IF Institutional Version" framework to evaluate reverse innovation as an indicator of innovation performance. A study with this focus could make valuable contributions, since the development of innovation in an emerging country and its subsequent adoption in a more developed country would demonstrate the commitment of developing countries to achieving technological advance and their results in relation to the capacity and control of innovations. Another suggestion for future research would be to empirically test the 13 propositions in the conceptual model, in other automakers in Brazil, or other emerging countries, and to compare the results found.

REFERENCES

- Ahuja, G. (2000). Collaboration networks, structural holes, and innovation: A longitudinal study. *Administrative Science Quarterly*, 45 (3), 425–455.
- Chan, C.; Isobe, T. & Makino, S. (2008). Which country matters? Institutional development and foreign affiliate performance. *Strategic Management Journal*, 29, 1179–1205.
- Cheng, H.-L. & Yu, C. M. J. (2012) Adoption of Practices by Subsidiaries and Institutional Interaction within Internationalised Small- and Medium-Sized Enterprises. *Management International Review*, 52 (1), 81-105.
- Chittoor, R.; Aulakh, P. & Ray, S. (2015) Accumulative and assimilative learning, institutional infrastructure and innovation orientation of developing economy firms. *Global Strategy Journal*, 5, 133-153.

- Dikova, D. (2009) Performance of foreign subsidiaries: Does psychic distance matter? *International Business Review*, 18, 38–49.
- Dimaggio, P.J. & Powell, W. (1991). The iron cage revisited: Institutional isomorphism and collective rationality in organizational fields. *American Sociological Review*, 48 (2), 147-160, 1983. In: DiMaggio & Powell (org). *The New Institutionalism in Organizational Analysis*. Chicago and London: The University of Chicago Press.
- Eisenhardt, K. M. (1989). Building theories from case study research. *Academy of Management*, 14 (4), 532-550.
- Ferrato, E.; Carvalho, R. Q.; Spers, E. E. & Pizzinato, N. K. (2006). Relacionamento interorganizaional e hold-up no setor automotivo: uma análise sob o enfoque da economia dos custos de transação. *Revista de Gestão USP*, São Paulo, 13 (1), 75-87.
- Gaur, A.S. & Lu, J.W. (2007). Ownership Strategies and Survival of Foreign Subsidiaries: Impacts of Institutional Distance and Experience. *Journal of Management*, 33 (1), 84–110.
- Gilsing, V.; Nooteboom, B.; Vanhaberbeke, W. Dusters, G. & Oord, A. (2008) Network embeddedness and the exploration of novel Technologies: technological distance, betweenness centrality and desnsity. *Research Policy*, 37, 1717-1731.
- Globerman, S. & Shapiro, D. (1999). The impact of government policies on foreign direct investment: the Canadian experience. *Journal of International Business Studies*, 30 (3), 513–515.
- Gulati, R.; Nohria, N. & Zaheer, A. (2000) Strategic Networks. *Strategic Management Journal*, 21, 203-215.
- Gulati, R. (1998). Alliances and Networks. *Strategic Management Journal*, 19, 293-317.
- Hertwig. M. (2012). Institutional effects in the adoption of e-business-technology Evidence from the German automotive supplier industry. *Information and Organization*, 22, 252-272.
- Hillman, A. J.& Wan, W. P. (2005). The determinants of MNE subsidiaries' political strategies: Evidence of institutional duality. *Journal of International Business Studies*, 36, 322–340.
- Jiang, R.J.; Tao, Q. T. & Santoro, M.D. (2010). Alliances portfolio diversity and firm. *Strategic Management Journal*, 31, 1136–1144.
- Knoke, D. (2001). *Changing organizations: business networks in the new political economy*. Boulder, CO: Westview.
- Kostova, T. & Zaheer, S. (1999). Organizational legitimacy under conditions of complexity: The case of the multinational enterprise. *Academy of Management Review*, 24 (1), 64-81.
- Kostova, T. (1999). Transnational transfer of strategic organizational practices: A contextual perspective. *Academy of Management Review*, 24 (2), 308-324.
- Landau, C.; Karna, A. & Sailer, M. (2016). Business model adaptation for emerging markets: a case study of a German automobile manufacturer in India. *R&D Management*, 46 (3), 480-503.
- Lazer, D. & Friedman A. (2007). The network structure of exploration and exploitation. *Administrative Science Quarterly*, 52, 667-694.
- Macedo-Soares, T. D. L. v. A.; Turano, L.; Esteves, F.; Porto, C. (2016). International alliance portfolios and innovation: a proposal for an analytical model based on bibliographic and bibliometric research. *Journal of Global Business and Technology*, 12 (1), 1-22, Spring Issue.

- Macedo-Soares, T. D. L. v. A. (2011). Ensuring Dynamic Strategic Fit of Firms That Compete Globally in Alliances and Networks: Proposing the Global SNA - Strategic Network Analysis - Framework. *Revista de Administração Pública*, 4 (1), 67-105.
- Macedo-Soares, T. D. L. v. A. (2014). Estratégias de empresas orientadas à inovação por meio de portfólios de alianças internacionais: proposta de um ferramental analítico. *FAPERJ Project No. E -26/201.440/2014-BBP- Cientista do Nosso Estado*.
- Macedo-Soares, T. D. L. v. A. (2015). Gestão estratégica voltada para inovação no caso de empresas em alianças e redes, no contexto da globalização. *CNPq Project, PQ 1 B, Protocol No. 1934859453186350*.
- Marinova, S.; Child, J. & Marinov, M. (2012). Institutional Field for Outward Foreign Direct Investment: A Theoretical Extension? In Tihanyi, L., Devinney, T.M. (eds.), *Institutional Theory in International Business and Management* (pp. 233–261). Emerald Group Publishing Limited, Bingley.
- Meyer, J. W. & Rowan, B. (1977). Institutionalized organizations: formal structure as myths and ceremony. *American Journal of Sociology*, 83(2), 340-363.
- Neto, M, S & Truzzi, O.M. (2009). Posicionamento estrutural e relacional em redes de empresas: uma análise do consórcio modular da indústria automobilística. *Revista Gestão e Produção*. São Carlos, 16 (4), 598-611.
- North, D. C. (1990). *Institutions, institutional change and economic performance*. Cambridge: Cambridge University Press.
- OECD (2005) – *Manual of Oslo*, 3rd ed., Available at: <<http://download.finep.gov.br/imprensa/oslo2.pdf>>. Consulted in November 2014.
- Ozcan, P. & Eisenhardt, K. (2009). Origin of alliance portfolios: entrepreneurs, network strategies, and firm performance. *Academy of Management Review*, 52 (2), 246-279.
- PINTEC (2015). *Pesquisa de Inovação Tecnológica*. Instituto Brasileiro de Geografia e Estatística – IBGE, 2011. Available at: <<http://www.pintec.ibge.gov.br/downloads/pintec2011%20publicacao%20completa.pdf>>. Consulted in August 2015.
- Porter, M. E. (1986). *Estratégia Competitiva: Técnicas para Análise de Indústria e da Concorrência*. Rio de Janeiro: Ed. Campos.
- Porto, C. B. & Macedo-Soares, T. D. L. v. A. (2016). Model for analyzing from an institutional perspective firm alliance portfolios' implications for innovation performance: focus automotive sector. In: *Readings Book of GBATA International Conference 2016*, 440-450, Dubai, 2016.
- Porto, C. B. (2016). Proposta de um arcabouço analítico na perspectiva institucional para avaliar as implicações dos PAs para o desempenho em inovação de empresas multinacionais em países emergentes: Foco no setor automobilístico. 2016, 323f. PhD Thesis, Pontifical Catholic University of Rio de Janeiro.
- Porto, C. B.; Pinho, M. L. C. A.; Paula, F. O. & Macedo-Soares, T. D. L. v. A. (2016). Strategic groups of multinational automotive firms in Brazil: identifying opportunities in the midst of a crisis. In: *Readings Book of GBATA International Conference 2016*, 597-611, Dubai, 2016.
- Rossoni, L. & Machado-da-Silva, C. L. (2010). Legitimidade, Governança Corporativa e Desempenho: Análise das Empresas da Bolsa de Valores de São Paulo. In *XXXIV ANPAD Proceedings. 25-29 Sept. 2010*.
- Sampson, R. C. (2005). Experience effects and collaborative returns in R&D alliances. *Strategic Management Journal*, 27 (11).

Suchman, M. C. (1995). Managing legitimacy: Strategic and institutional approaches. *Academy of Management Review*, 20 (3), 571-610.

Turner, J. C. (1991). *Social Influence*. Pacific Groove: Brooks/Cole.

Williamson, O. (1985). *The Economic Institutions of Capitalism: Firms, Markets, Relational Contracting*. Free Press, New York.

Yin, R. K. (2010). *Estudo de caso: planejamento e métodos*. 4ª ed. Porto Alegre: Bookman.

WATSHERE: A WATSON COGNITIVE SYSTEM TO NAVIGATE SOCIAL/HEALTH RESOURCES FOR PUBLIC SCHOOLS

**Anna Poulakas, Alon Yoeli, Sebastian Deossa, Caio Batista de Melo,
D. Frank Hsu, Dawn Johnson Adams, Cesarina Javier and
Anita Vazquez Batisti
Fordham University, U.S.A.**

ABSTRACT

Cognitive computing aims to augment human intelligence with machine intelligence in an information system which can handle structured and unstructured data. Such a cognitive system entails building a corpus with relevant data, improving the corpus with more acquisition of data, and analyzing these data with machine learning algorithms. It then presents the output solution as search results or using visualization. In this paper, we describe a project to design and implement Watson cognitive apps to navigate social/health resources using the IBM Watson system. Although our system was initially designed for community elementary schools in the Bronx, it can be used by other domain application with slight modifications.

Keywords: Big Data, Bluemix, Cognitive Systems, IBM Watson, Social/Health Resources.

INTRODUCTION

Due to the advent of networking, information and communication technology, the world is instrumented and interconnected [5]. Moreover, imaging technique and information appliances (such as sensors and mobile phones) enable us to acquire tremendous amounts of data in a short time. We are living in the Big Data era and in the data-driven period, what Jim Gray called “the Fourth Paradigm” in the scientific discovery process pipeline [4, 12].

Big Data (BD) has at least four characteristics: volume, velocity, variety, and value [10, 12]. The **volume** aspect of BD involves huge amounts of complex data. Traditional database management system using relational database model is not enough to deal with BD. Database systems using other models such as document store, column store, and graph database have been constructed by corporations (in particular social networking companies) that are data intensive in their core business [10, 13]. **Velocity** refers to streaming data at a high speed. In order to avoid piling up data quickly, one might have to compute and reduce the data which are not relevant at the data gathering point. **Variety** refers to different types of data (image, text, video, etc.) and data from a variety of sources, systems, and software. Due to the variety and complexity of data (structured vs unstructured, spatial vs temporal, logical vs perceptive, etc.), analyzing techniques vary. Traditional hypothesis-driven statistical approach is not enough [14]. Computational approach with various data-driven algorithms in machine learning and combinatorial fusion has been used widely [2, 6, 8]. More recently, cognitive computing was proposed [1, 7, 8, 9] to augment human intelligence with machine learning intelligence in an adaptive system that can deal with structured and unstructured as well as human spoken and Q&A systems. Finally, the **value** aspect of BD ensures that the information derived from the data and the knowledge extracted from the information is useful and actionable for decision making, problem solving, solution finding, and policy making.

Statement of Problem

In this paper, we describe a project on cognitive computing we undertook during the period of October 2015 –

December 2016. In New York City as part of a holistic approach to student learning, over 150 public schools are implementing the Community Schools Model. These schools embrace a “whole child” approach that supports the social, emotional, and physical and academic needs of their students and families. The Borough of the Bronx, New York has the largest number of families who on a daily basis are faced with numerous challenges both at home and in the classroom. The highest need within the Borough of the Bronx, New York among the school age population (ages 3-10 years) is social emotional health. While there are a large number of resources available in the borough, there is need for a more time sensitive and less fragmented approach for schools to assist their students and families in utilizing these resources. Using the IBM Watson technology, this project built a cognitive Q & A system for social workers and administrators in public elementary schools in the Bronx, New York (grades Pre-K - 5) implementing the Community School Model. It provides and enhances full and equitable access to social health resources in the Bronx.

The highest need within the Borough of the Bronx, New York among the school age population (ages 3-10 years) concerns social emotional health as we indicated above. Our project focuses on mental health issues such as Attention Deficit Disorder (ADD), Oppositional Defiant Disorder (ODD), Post-Traumatic Stress Disorder (PTSD) and the autism spectrum, as well as resources for a myriad of social services. This project represents a three way (Industry, Academia & Government) collaboration - IBM, Fordham, and NYCDOE. It entails the design and implementation of Watson cognitive apps to navigate social/health resources using the Watson Engagement Advisor (WEA) systems through IBM cloud. This app was initially designed for community elementary schools in the Bronx. However, it can be readily modified to be used in other domain applications and other geographical area. Currently, we are implementing this app using IBM Bluemix systems (Conversation and Discovery).

The remaining sections of this paper are as follows: Section 2 will cover cognitive computing and the cognitive system platform of IBM WEA. Section 3 covers the project’s personnel, time table, design process, implementation procedure, and lessons learned. Then Section 4 concludes the paper with a summary and discussion of further work in the future.

Cognitive Computing and the Watson Cognitive System

The history of computing can be dated to the beginning of the 20th century when machine tabulators were used. This was called “The Tabulating Era” followed by the “The Programming Era” when electronic computers were created in the 1950’s [8, 9]. Inspired by J.C.R. Licklider’s pioneering work on “Man-Computer Symbiosis”, symbolized system have been built and used to perform intellectual processes and solve complicated problems [9, 11]. Then in February 2011, a symbiotic system called Watson, designed and built by IBM, defeated two world champions at Jeopardy! This marked the beginning of “The Cognitive Era” in science, technology, society and business. A cognitive computing system (CCS) has the following characteristics:

- I. **Data and Data Model:** A CCS can take structured data from a database system as well as unstructured data in images, text and queries. The corpus of data or knowledge representation is updated constantly.
- II. **Understanding and Learning:** A CCS strives to understand content and context from other systems or landscape and actions in the environment through repeated learning and adaptation using analytical technologies, intelligent inference, and combinational fusion algorithms.
- III. **Hypothesis Generation and Scoring:** CCS generate multiple hypothesis scores for each evidence using multiple algorithms, combine all the evidence for each possible solution, and compute confidence score.
- IV. **Visualization and Interpretation:** Due to the unstructured nature of the data, the multifacetedness of the corpus, and probabilistic characteristics of the evidence, CCS’ use visualization tool to examine and interpret data for decision making and policy formulation.

As such, cognitive computing encompasses several subjects: natural language processing (NLP), information retrieval system (IRS), machine learning and information fusion (MLIF), database and knowledge representation (DKR), and data visualization and analysis (DVA).

In this project, we used the IBM Watson Q&A system. The Q&A system is able to take questions and output a list of answers with confidence through multiple hypothesis generations, pruning, evidence scoring, merging and

ranking [7]. This Q&A technology is incorporated into the Watson Engagement Adviser (WEA) system which consists of the following operational steps:

- (1) Define user case and best practice,
- (2) Identify and describe end users and create user interface,
- (3) Q&A process: collect user questions and answer questions,
- (4) Create corpus: questions and answers configuration, identify headers for each document, answer and evidence sources update,
- (5) Train Watson: train and analyze ground truth, refine ground truth, and
- (6) Deploy Watson: user validation and solution maintenance.

THE PROJECT

The Team and Time Table

Our team consists of students in the Fordham Laboratory of Informatics and Data Mining (FLIDM) who major in a variety of disciplines ranging from mathematics, computer science, to political science and pre-law program students. Included in this project are two domain experts: one Community School Director and one bilingual social worker, from the Center for Education Partnerships in the Graduate School of Education who are embedded at PS85, a community elementary school in Bronx County, NY. During October 1, 2015 and December 25, 2016, we met at least once a week for two hours. The goal of the “WatsHere” project was to create and implement a Watson Cognitive System to navigate social health resources for public schools. Our first stage is for the elementary school PS85. The project’s first phase was completed and demonstrated on December 26, 2015 and documented [3].

Q&A’s and the Corpus

For the steps (3) and (4) in the WEA system, the team created over 120 questions in five categories. (A) Healthcare, (B) Living essentials, (C) Mental Health, (D) Community, and (E) PS85.

In the corpus, we have over 125 documents with headers included. WEA can take documents with file format in word, JSON, PDFs and HTML. For simplicity, we currently use word format. Each time a new question was put into the system, it would “train” Watson, thus making Watson smarter every time when answering the questions. Extreme cases were taken to split a question into two questions or combine more questions into one according to the content/context issue and availability of source evidence.

A Few Examples

Since we had a very interdisciplinary team working on this system, our questions were tailored and then modified to exactly what we needed. Using the WEA, we were able to engage with sophisticated technology. Figure (1) illustrates the homepage. This would be the initial screen team members would view after logging in with their credentials. Here we see three rectangles each respectively labeled “Manage Corpus”, “Train Watson” and “Test”. Manage Corpus would be the box we choose to upload documents which we would then “match” with the questions. Most of our time was spent in “Train Watson”. Here we would type the question and then it would be released into our corpus. Yet before we would officially allow the question to go into the corpus we would match it to a document that would answer the question being asked. In essence Watson was told that this particular question matched a particular document. In order to ensure that Watson was being trained and getting smarter, we would put “tags” along with each question. Thus allowing key words to stand out, allowing questions and answers that were similar or dealt with information that

pertained to a particular subject to be grouped together.



Figure 1

Figure (2A) in Appendix 1 exhibits a screenshot of our computer screen as if we clicked on one of the three boxes on the first page labeled “Train Watson” (see Figures 2A, 2B, and 2C in Appendix 1). In the box at the top we would add our question, in doing so we would set it with the respective document to answer the question. Our questions ranged from a variety of categories (A), (B), (C), (D), and (E). Yet each and every one of them was carefully selected and discussed with both the students and the Community School Director and the social worker. The social worker has first hand experience with the students and parents of PS85, the staff are a direct source of information that was needed for such a project. Figure (2B) shows an example of one of the questions which was designed specifically for PS85. Although it is very basic, it happens to be quite vital. The question, “who is the principle?” followed by the answer which is matched, “Mr. Theodore Husted, to contact call (718)***-**** then dial 0 (operator).” This was *clustered* with two other questions similar in nature. What is the purpose of doing so? In essence this is what makes Watson smarter, the greater the variety of questions and pairing the proper answer document with it, the smarter Watson will become. It is through repetition and the constant pairing of key words with the precise documents that Watson is trained and learns the desired information. Figure (2C) shows the screen with each of the documents as they are uploaded. Although we did not tweak this area much, it serves as more of the information portal. This essentially is the area where each and every document is stored with the proper information and headers that answer the questions presented.

Figure (3) is the initial “test” page, this is where we would type the question and in return Watson should bring forth the document we have set to match with that designated question. When we ask the question and Watson provides the answer which we desire, we could click the “thumbs up” which states “useful”. Essentially this assures Watson that the response brought forth is the correct one. It also assures us that in the future when this question is asked the same document should be brought forth. One would think that this entire process would run smoothly since all questions at this point were assigned a document and clustered. However, this was not the case. There was much work done in this phase, it was time consuming and repetitive. However ultimately this represents one of the most essential parts of the project. In theory we are telling Watson if what we previously stated was correct and in response

it is able to process and bring back to us the information we seek.

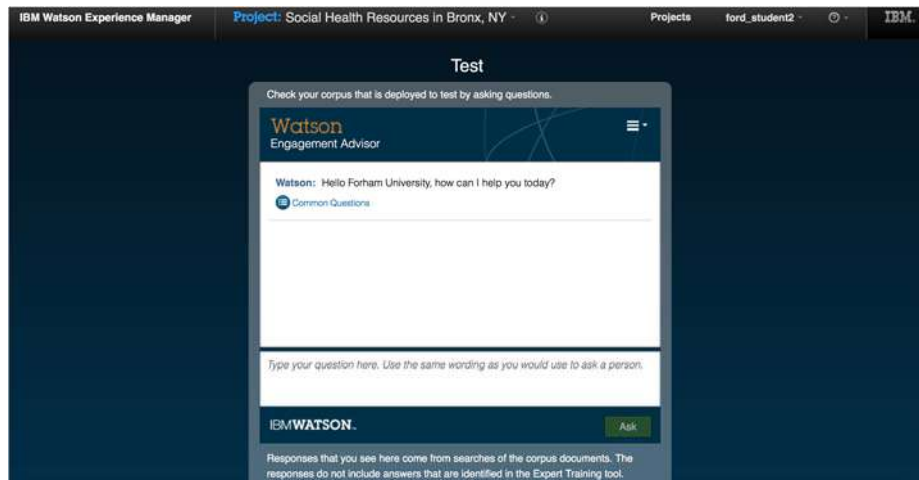

Figure 3

The following five figures in Appendix 2, are taken from each of the designated categories A, B, C, D, and E respectively to show exactly how Watson operated (see Figures 4A, 4B, 4C, 4D, and 4E in Appendix 2). Figure (4A) shows the question “Joseph”, which is simply the default name used asked, “where are urgent care providers located?” Watson responds, the answer is provided in a document which our team carefully constructed. The urgent care providers listed are all within the local vicinity of PS85. The purpose of this is to help the social workers, students and parents to become more aware of the facilities located near them. In general, our category (A) for “healthcare” consisted of questions that related to general healthcare and facilities. Figure (4B) in Appendix 2 demonstrates one of the questions from our living essentials category, more specifically, “shelters for single parents?”. Since many of the students come from families at a disadvantaged level as designated by New York City standards, many of them face housing challenges. Therefore, the social worker typically receives numerous questions pertaining to housing. Our team deemed it necessary to include extensive questions about different housing situations. The questions exemplified here are one of the more basic questions. When Watson gives us an answer, he also tells us how confident he is in his response. When a question was presented to Watson, he returns an answer document. On the bottom left corner, there are three boxes. If Watson is extremely confident of the response all three square boxes would be shaded blue, if there is less confidence only two would be blue and so forth. This was a good detection and measure for us in the testing phase. It allowed us to see how much more time we needed to devote to train Watson to be more knowledgeable in certain areas. For this particular example, we see the response Watson providing us having a confidence level of two blue boxes. We attribute this to the fact that there were numerous questions dealing with shelters. Therefore Watson initially was not sure which list of shelter documents to bring forth since they were grouped based on different criteria.

Figure (4C) in Appendix 2 depicts one of the examples from our mental health category (C). The question is as follows, “where are mental health care providers that provide psychosocial evaluation?” In response, the locations we trained Watson to provide were all within close proximity to PS85’s zip code of 10458. Figure (4D) in Appendix 2 draws upon the category of community. The social workers and principal of the school expressed a great need for information that dealt with the greater community. This included a variety of aspects from local police stations to recreational activities, even locations where students can access computers. The figure (4D) depicts this exactly with the police precinct. Our last category is PS85 (E). These questions and answers are derived directly from information based on the school. It covers basic and general information pertaining to the school in addition to the names and phone numbers of the administration. Figure (4E) in Appendix 2 exemplifies a question presented of who is on the PTA, Parent-Teacher Association of PS85. This information can be very helpful for a parent as the PTA is an active association within the school which could assist with the needs of other parents, teachers as well as students. As explained above these happen to be a select few of the many questions and answers (in documents) we compiled. They

reflect a sampling from each one of five categories established.

Lessons Learned

As in any project there were numerous lessons learned throughout each phase. It exposed us to a great deal of valuable information which was so vital throughout.

- a) This project was thought of and developed through a fusion of multiple disciplines. It encompassed a broad area of academic perspectives. They were knowledgeable participants, each representing various subject areas the project was to deal with. Having the perspective of these various people was indeed a true asset. It not only allowed us to view the project through a variety of lenses, but also encompassed key information in regards to all backgrounds. This not only assured for clear communication amongst our group members, but also an efficient manner to relay the information.
- b) The technological aspect of the project required most of us to familiarize ourselves with the program and organization of questions and documents. This fostered a neat and clear system of the questions and documents. Drawing upon communication yet again, we found this to be easy due to the expertise each of our members possessed.
- c) Although the project was centered and greatly focused on education, the process behind it was not solely as such. Thus having individuals with experience and exposure to technology, school administration and the operations of systems proved invaluable. Working closely with IBM, we consulted technical and their support staff for help and guidance.
- d) In the process of doing our research, it was evident that there was no specific or logical form in which we could solve all the issues that arose. With this in mind, we found that there can be multiple solutions to solve a given problem.
- e) The entire process was an ongoing learning process. When first approached with this project, it appeared to be rather simple. But when a case was given and a grander scope was revealed, we soon discovered the complexities of the implementation of such a project. However, all the team members remained dedicated and persevered, determined to accomplish the focus.

CONCLUSION

The world we live in is ever changing, each day brings forth new and innovative ideas especially in the technological world. It is our task and obligation to understand how they can be implemented to better serve our communities. When the resources are available, it is simply a matter of understanding and organizing it in a way that will benefit those who aspire to utilize it. Projects such as this particular one help expose to others in various fields how vital Big Data is to all us and our future.

Summary

Our work encompassed multifaceted disciplines aiding in the plethora of information required. Drawing from numerous resources we were able to discuss and focus on the most vital needs of those in the Bronx community, which our project is originally designed to serve. Our two team members, the Community School Director and social worker who directly work with the students, enable us to keep our direction clear and concise. Other team members were then able to utilize the information given to them, analyzing it and bring it forth in an organized manner. Our project is not only relevant in using new technology yet sets a precedent for how technology can and will be used in the future. We already see Watson thriving in the medical world and financial sector, it is our hope that it can do the same in the world of education. We believe our project can help bring forth an entire trend of the educational sector with

the cutting edge technological one.

Future Work

The WatsHere team continues to remain focused. The team is working on a system to implement our datasets and Q/A's from the Watson WEA framework onto IBM Bluemix apps known as Conversation and Discovery. The Watson WEA framework uses logistical regression and information retrieval for building platform while the Bluemix Discovery uses machine learning and deep learning technology. In theory and in practice, this will allow us to better organize our data and provide the answers in a more precise and dynamic manner which will greatly benefit the user. The administration of PS85 along with the Bronx Borough President's office are strong advocates for programs such as this in assisting local Bronx community schools. Not only will it aid to improve their access of data but it will provide an easier and faster system and environment for the social workers who serve the students and the parents. Furthermore, the Wats Here team is greatly interested in creating an app and/or website which would allow parents to access all the information at their fingertips. There is also discussion of connecting the system with common social media platforms, which would allow individuals to access on a more casual and private manner. Work on the next phase of this project is currently underway and will continue for the next years.

Acknowledgement

We are grateful to Dr. Lilian Wu of IBM for funding and supporting students in the Laboratory of Informatics and Data Mining. We also thank Richards J. Rodts II and Armen Pischdotchian of IBM for their help and support in using Watson system. Finally, the encouragement of Mr. Ruben Diaz, President of Bronx County, is gratefully appreciated.

APPENDIX 1

Figure 2A

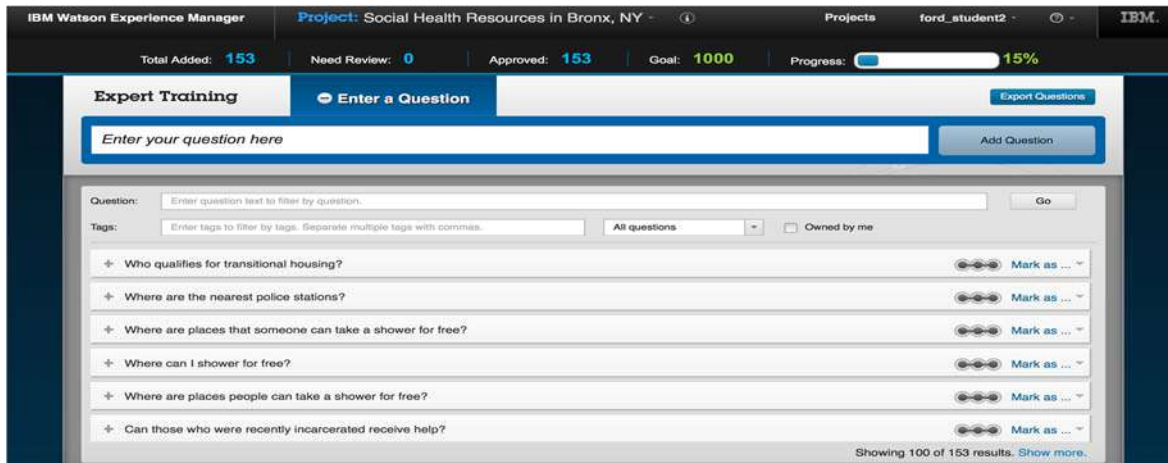

Figure 2B

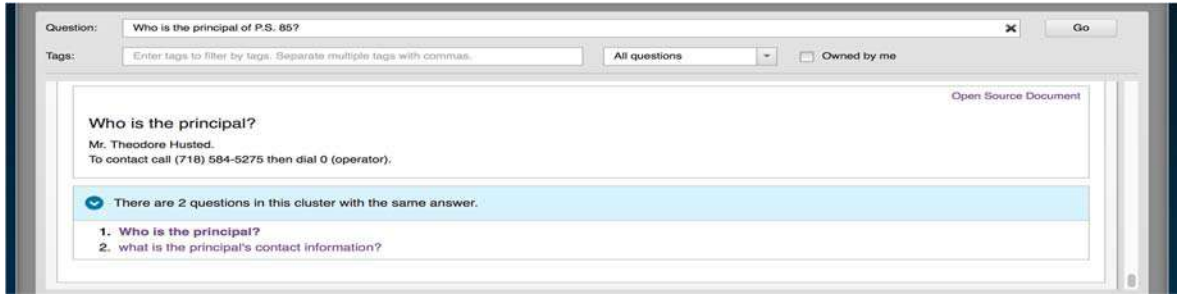
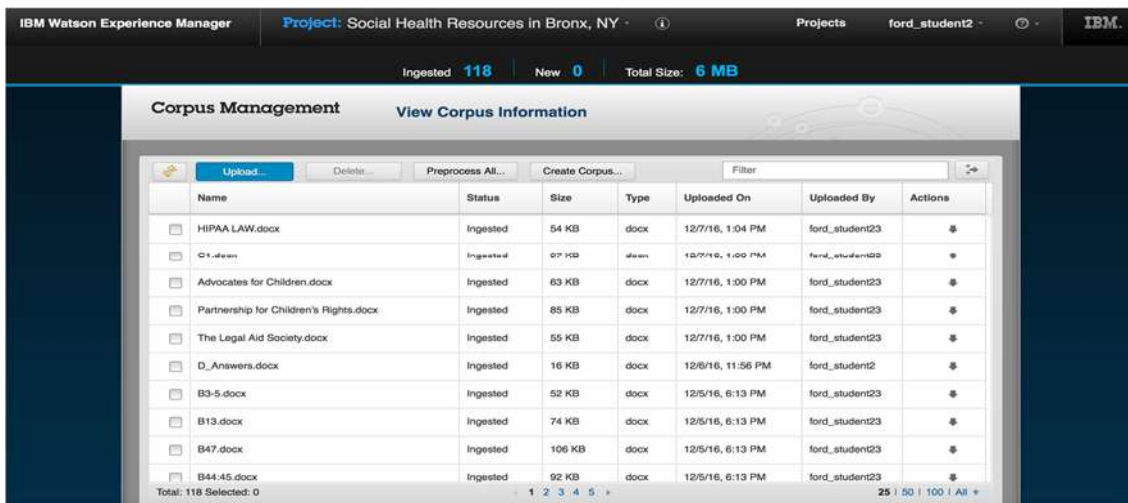

Figure 2C



APPENDIX 2

Figure 4A

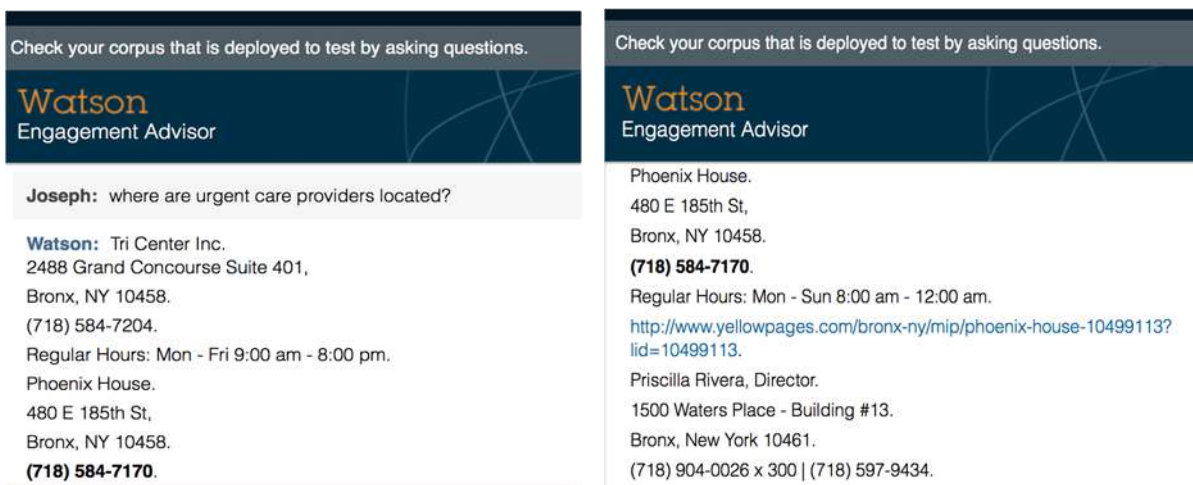

Figure 4B

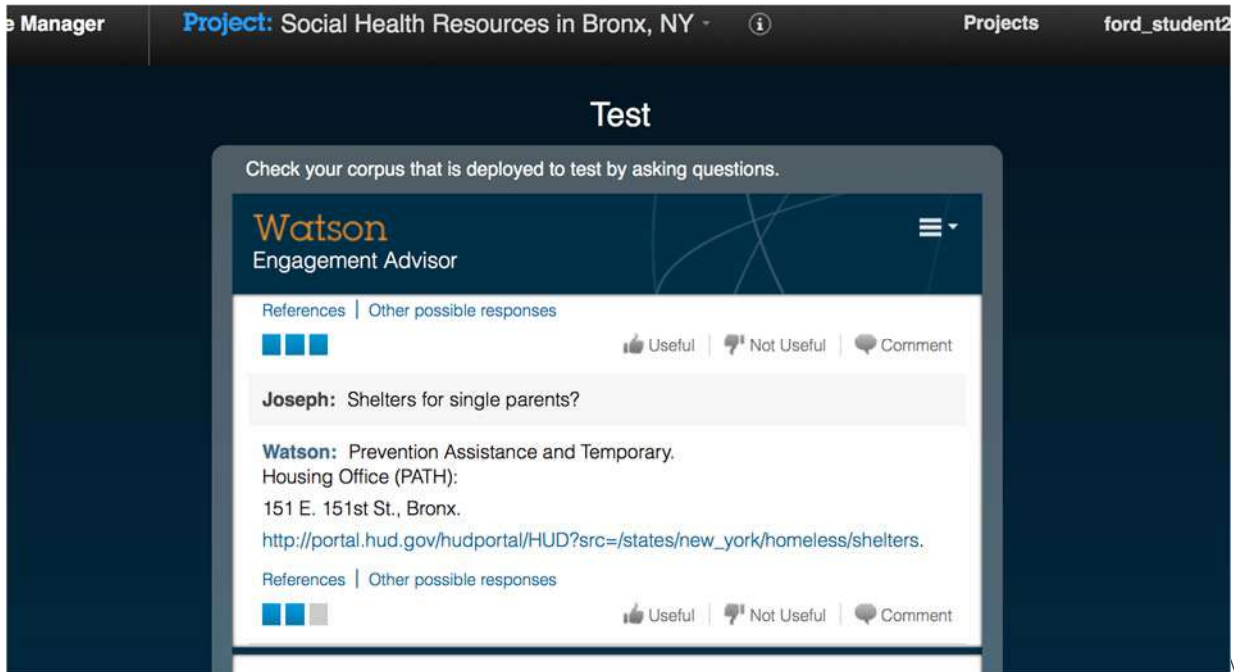

Figure 4C



Figure 4D

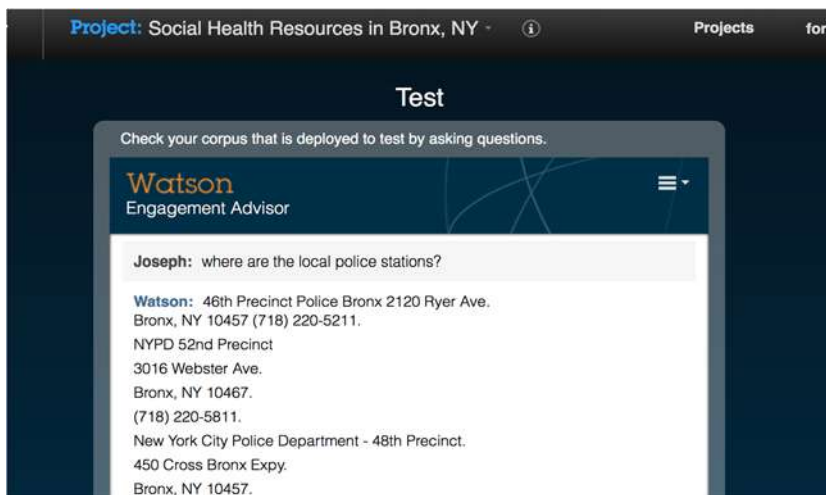
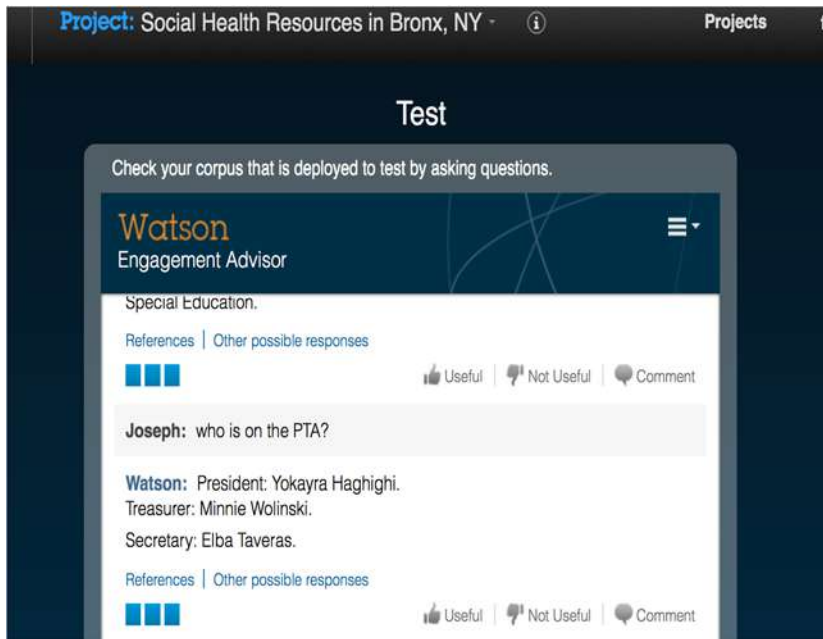

Figure 4E



REFERENCES

- [1] G. Banavar; Learning to Trust Artificial Intelligence Systems; Accountability, Compliance and Ethics in the Age of Smart Machines, IBM Global Services, 2016.
- [2] C. M. Bishop; Pattern Recognition and Machine Learning; Springer, 2007.
- [3] Bronx TV news; <http://www.bronxnet.org/tv/bronxnetpackages/8614-social-health-resources-app-developed-for-ps-85> , (January, 2017)
- [4] T. Hey et al (edited); “Jim Gray One-Science: A Transformed Scientific Method; in The Fourth Paradigm”, Microsoft Research, (2009), p. 19-31
- [5] D. F. Hsu; Building a Secure and Sustainable Cyberspace Ecosystem: An Overview, in Advances in Cyber Security; Technology, Operations, and Experiences, Fordham University Press, 2013
- [6] D. F. Hsu, B. S. Kristal, and C. Schweikert; Rank-Score Characteristic (RSC) Function and Cognitive Diversity, International Conference on Brain Informatics, (2010), p. 42 – 54.
- [7] J. S. Hurwitz, M. Kaufman, and A. Bowles; Cognitive Computing and Big Data Analytics, John Wiley & Sons, Inc., (2015), 266 pages.
- [8] J. E. Kelly III; Computing, Cognition and the Future of Knowledge: How Humans and Machines are Forging a New Age of Understanding, IBM Global Services, 2015
- [9] J.E. Kelly and S. Hamm; Smart machines: IBM’s Watson and the era of Cognitive Computing, New York, Columbia University, 2014
- [10] K.-C. Li, H. Jiang, L. T. Yang; and A. Cuzzocrea; Big Data: Algorithms, Analytics, and Applications; CRC Press 2015.
- [11] J.C.R. Licklider; Man-Computer Symbiosis, IRE Transactions on Human Factors in Electronics, 1960.
- [12] V. Mayer-Schonberger and K. Cukier; Big Data: A Revolution That Will Transform How We Live, Work, and Think, Houghton, Mifflin and Harcourt Publishing Group, 2013.
- [13] I. Robinson, J. Webber, and E. Eifrem; Graph Databases: New Opportunities for Connected Data; O’Reilly Media, 2015.
- [14] D. J. Spiegelhalter, Science, (2014), 345, p. 264 – 265.
- [15] T. Stoelker; Learning from Watson, Teaching Watson, Inside Fordham Science, Oct. 29, 2015.

EFFECTIVENESS OF THE ONLINE LIBRARY DATABASE IN THE UNIVERSITY: A CASE STUDY OF THE UNIVERSITY OF JOHANNESBURG BUNTING ROAD CAMPUS

Anup Pradhan and John Francis Agwa-Ejon
University of Johannesburg, South Africa

ABSTRACT

Academic library is a power house of information and plays a vital role in providing access to a wide range of academic resources to the faculty, students and staff of the university. This paper examined the effectiveness of the online library services provided by one of the campuses of the University of Johannesburg. The study revealed that the online services and resources of the Auckland Park Bunting Road (APB) campus library is satisfactory and adequate. The students, faculty and staff of the APB campus are well aware of the e-library and frequently accessing the online services. Accessibility (24/7 and off-campus) is reported to be the major benefit of using e-library, the other benefits include ease of searching, downloading and sharing materials. The e-library services is frequently used for both academic and research activities.

Keywords: University of Johannesburg, APB campus, library, e-resources, digital database.

INTRODUCTION

A library is a knowledge bank that provides necessary information resources and services to its users. Academic libraries, which are the primary source of scholarly resources, play a vital role in providing access to a wide range of academic resources to the faculty, students and staff of the university. Academic libraries are essential for all teaching, learning and research activities in a university (Adegun et al., 2015). With the availability of e-resources, the majority of the universities around the world has transformed their paper based cataloguing system to online database system. Information technology has transformed the format of resources and the way users seek, obtain and use resources (Ayob, 2011). The online database provides an easy access to global e-resources (journals, research articles, books, magazines, etc.) with a simple click of a button and most importantly it can also be accessed off campus.

The University of Johannesburg (UJ) is a major institution of higher education in South Africa comprising nine faculties with more than 90 departments. UJ has four urban campuses spread over the city of cosmopolitan Johannesburg and each campus has its own library, which provides access to the extensive electronic database to the users. In 2014, the university introduced handheld devices (e.g. tablet) into first year classrooms and has recently made it mandatory for the first year students to use e-books for the coursework to minimize the cost spent on buying textbooks. In 2015, the digital collection of UJ libraries has increased to 32% from a baseline of 22% (Bradbury, 2016). Whilst the number of print journals decreased by 0.8% from 2014 to 2015, the number of e-journals and e-book titles has increased by 10.6% and 78% respectively.

This paper evaluates the online services provided by the University of Johannesburg Bunting Road campus, commonly known as APB campus. The study examines how effectively the users have utilized the online library database for teaching and learning purposes. The study will identify users' satisfaction level and provide recommendations for the necessary improvements of the online services provided by APB campus library.

REVIEW OF LITERATURE

Academic libraries are the resource of academic excellence for any university. Students and staff frequently use library services for several academic and research activities, for instance to use study space, to borrow materials, to use internet, to print and photocopy, etc. Libraries must be able to provide effective services to the users and frequently emphasize on improving facilities and enhancing information technology to stay up-to-date (Abdallah and Bilal, 2015). Libraries must have a provision of: (i) materials for undergraduate level; (ii) materials to support faculty, external and collaborative research; (iii) expensive standard works for professionals; (iv) materials for personal development; (v) specialized information on the locality; and (vi) cooperation with other academic libraries to develop a network (Nok, 2006). Users of these libraries are entitled to competent librarians and adequate collections of easily available and accessible resources (Adegun et al., 2015).

Academic libraries in Africa have been facing problems due to lack of funds and information resources for many years. In recent days, automation of library services is presenting a new problem because it requires acquisition, selection and cataloguing of online resources; construction of database; and providing information literacy training to library staff and users (Nok, 2006). These training activities should consider different user groups who use different methods and have different reasons to access online resources (De Groote and Dorsch, 2003).

E-library is an organized and well-managed information system available over a computer network via internet, which supports searching and use of digital resources (Jeng, 2005). It has reduced the number of users visiting library because more resources is becoming available online that can be accessed remotely, however library visits are increased during examination periods (Nkamnebe et al., 2014). The primary advantage of e-library is the accessibility (24/7) of information resources from anywhere (De Groote and Dorsch, 2003; Chrzastowski, 2011). It is preferred due to its ease of downloading and saving pdf files in personal computer, and ease of reading content from the computer screen. It enables library to provide broader collection of resources with little or no additional space. However, digital resources without links to full text will have lower use (De Groote and Dorsch, 2003). Majority of the users' access limited number of databases and are not aware of the availability of diverse databases beside the one they are using regularly. Furthermore, lack of information searching skills (e.g. choosing convenience over substance and accuracy), limited space, low bandwidth and erratic power supply may hinder the optimal use of digital resources (Okite-Amughoru et al., 2014).

E-library also has economic benefits compared to traditional paper based library. A study found that e-library lowers space costs, material costs and equipment costs (Connaway and Lawrence, 2003). Compared to the paper-based library, e-library reduced the costs for space, material and equipment by about 29%, 34% and 70%, respectively. The use of computers and internet has become very common in the university, but information literacy is not, hence the authorities must ensure that the users are aware of digital resources and their importance (De Groote and Dorsch, 2003). It is important that the students perform well in library information literacy and at the same time achieve better in their academic courses. A study reported a strong correlation between the information literacy rate and academic performance of the students (Moll, 2011). The study included the first year students of the faculty of Education at the Cape Peninsula University of Technology (CPUT). The study observed that students who did well in the information literacy assessment conducted by library also performed well in their academic courses. The retention and graduation of these students were observed to be influenced by the ability to access the library online (Stemmer and Mahan, 2015).

A study conducted in the Ankara University, Turkey reported that the use of all electronic databases within the library has increased over time (Atakan et al., 2008). The study reported that the majority of the faculty members are familiar with the existence of e-library and using the databases. The study also revealed that the number of scientific articles published by the university academicians have increased with the increase in the use rate of databases (e.g. Web of Science, Science Direct and Ebsco). The training activities on use of the databases can further enhance the digital services of the library. The tutorials used in trainings could be simply static ones or even highly interactive ones. Online tutorials (such as, Guide on the Side, GotS and screencast) were successfully tested by university libraries to teach information literacy and database searching skills (Sachs et al., 2013; Mery et al., 2014).

Since the library website serves as a key gateway to access e-library services, the website must be easy to use, efficient and satisfactory for users (Joo et al., 2011). Several researchers have conducted studies to examine users' satisfaction and effectiveness of e-library services (Jeng, 2005; Atakan et al., 2008; Mulla and Chandrashekara, 2009; Lamptey, 2010; Sahin et al., 2010; Joo et al., 2011; Boston University, 2013; Khan, 2014; Nkamnebe et al., 2014; Okite-Amughero et al., 2014; Stemmer and Mahan, 2015). These studies used various survey tools to evaluate satisfaction and effectiveness levels of e-library services in the respective universities and region.

RESEARCH METHODOLOGY

A structured questionnaire was developed and distributed among students and staff who were available in the APB campus library. The respondents had the purpose of the study briefed individually. About fifty-eight respondents agreed to volunteer and filled the survey questionnaire. The survey was conducted inside the APB library over a period of one week. The survey questionnaires administered to the respondents consisted four sections: (i) demographics, such as age, gender, ethnicity, etc., (ii) access to computer and internet; (iii) general library usage, and (iv) access and usage of electronic library. Data obtained from the questionnaires were captured and analyzed using SPSS statistical software to draw inferences on the use of online library in the APB campus.

RESULTS AND DISCUSSION

Majority of the respondents (63%) were students, followed by staff (21%) and faculty members (16%). The age of the respondents ranged from 19 to 63 years, with a mean value of 29 years. The respondents belonged to all nine faculties of the university, majority of which belonged to the Faculty of Management (35%), followed by the Faculty of Engineering and the Built Environment (31%), the Faculty of Economic and Financial Sciences (11%), the Faculty of Humanities (11%) and the Faculty of Science (4%). The remaining four faculties (the Faculties of Law, Health Sciences, Education, and Art, Design & Architecture) represented 2% each.

The contribution of library is well acknowledged by the respondents (Table 1). They believe that library enables them to be productive, efficient and up-to-date, and even assist them to prepare for future career. Majority of the respondents (87% - 94%) rated the contribution of library from good to excellent, few respondents (4% - 13%) rated contribution as average and very few (2%) rated some of the contribution as poor. The respondents were aware of the computer facilities provided by the library and department, with more than 91% reporting to use those facilities. About 56% of the respondents accessed internet at school, whereas 28% respondents used mobile data plan to access internet and remaining 14% used internet at home and dormitories.

Almost 79% of the respondents reported to access the online library database or e-library. Out of 21% respondents who reported not to use online library access: (i) five respondents were unaware and not informed, (ii) four did not know how to use, (iii) three found it easier to work with printed materials, and (iv) unavailability of time, unavailability of help and slow internet speed accounted for one response each. Among the respondents who reported to access e-library, about 18% reported to use online services frequently, 44% used quite often and 38% used rarely. Majority of these respondents access online resources in the campus (53% at library, 19% at office and 16% using other campus network) and remaining 12% access e-library from home.

Table 1: Contribution of library

Contribution	Response in percentage (%)				
	<i>Poor</i>	<i>Average</i>	<i>Good</i>	<i>Very good</i>	<i>Excellent</i>
Efficient use of study time	1.9	3.7	18.5	42.6	33.3
Collection of required information	0	7.4	22.2	48.1	22.2
Stay up-to-date	0	11.5	25.0	32.7	30.8
Be a productive researcher	1.9	5.7	28.3	35.8	28.3
Be an effective instructor	0	13.2	35.8	32.1	18.9
Prepare for a future career	1.9	9.3	25.9	35.2	27.8

The respondents learnt about the online library access through various mediums (Table 2). Whilst 30% of the respondents learned by themselves or through library staff, others learned through university website and training sessions, university orientation week, and friends and faculty members. About 52% of the respondents sought assistance from library staff at times and remaining 48% did not report of using any kind of assistance. While majority of the respondents (83%) needed assistance to look for appropriate material or database online, remaining 17% sought help to save time of searching. The respondents mostly used online services to access online database, e-books and e-journals. The accessibility (24/7 and off-campus) of the services and resources were highlighted as the major benefits of e-library (Table 3). The respondents also identified ease of navigating, downloading and sharing materials as other benefits of e-library.

Table 2: Ways of learning about online library access

Library use	Response in percentage (%)	
	<i>Yes</i>	<i>No</i>
Self-trained	29.3	70.7
Friends or colleagues	19.0	81.0
University website or internet	20.7	79.3
Library staff	29.3	70.7
Faculty member or instructor	12.1	87.9
Training session	25.9	74.1
During orientation week	8.6	91.4

Table 3: Benefits of e-Library

Benefits	Response in percentage (%)	
	<i>Yes</i>	<i>No</i>
24/7 access	62.1	37.9
Easy to search & navigate	53.4	46.6
Easy download & storage	29.3	70.7
On and off campus access	32.8	67.2
Easy to copy & paste	15.5	84.5
Easy to share	15.5	84.5

The respondents used e-library to download relevant materials from the internet in order to do class assignments, writing thesis or dissertation, and complete class reports and papers for journals/ conferences (Table 4). The services of e-library were reported to be very important to carry out various research activities (Table 5). About 80% and more of the respondents mentioned e-library to be important for collecting research information, review and database.

Table 4: E-Library use by task

Tasks	Response in percentage (%)			
	<i>Never</i>	<i>Rarely</i>	<i>Often</i>	<i>Always</i>
Class assignments	10.6	21.3	42.6	25.5
Class reports	22.2	24.4	37.8	15.6
Thesis/dissertation	15.9	25.0	31.8	27.3
Journal papers	17.0	19.1	24.0	29.8
Conference papers	27.3	22.7	29.5	20.5

Table 5: Importance of e-Library in research activities

Research Activities	Response in percentage (%)			
	<i>Not important</i>	<i>May be important</i>	<i>Important</i>	<i>Very important</i>
To learn and develop research idea & topic	5.9	15.7	45.1	33.3
To collect scholarly information	0.0	10.0	44.0	46.0
To conduct review of literature	2.0	10.0	40.0	48.0
To explore database & dataset	4.2	14.6	39.6	41.7

Figure 1 presents the satisfaction level of the online services of the APB library. More than half of the respondents were satisfied with the current online services, however fewer respondents mentioned that the current online services (6%) are outdated and needs improvements (15%).

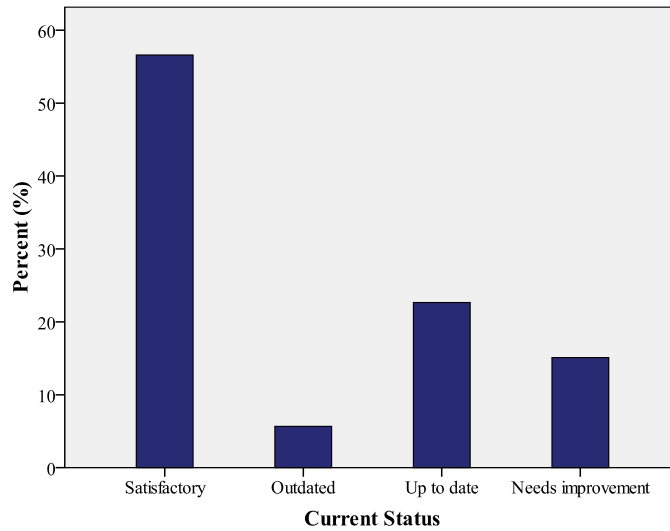

Figure 1: Current status of APB e-library

The attributes of the APB e-library were perceived as good to excellent (Table 6). The respondents were mostly satisfied with the accessibility (24/7 and off-campus) of the online services, and reported to enjoy easy downloading and time saved by e-library. However, about 20% of respondents were not that satisfied with the availability of software.

Table 6: Attributes of the APB e-Library Services and Resources

Attributes		Response in percentage (%)				
		<i>Poor</i>	<i>Average</i>	<i>Good</i>	<i>Very good</i>	<i>Excellent</i>
Accessibility	Easy to login	0	10.3	25.6	30.8	33.3
	Available 24/7	0	2.6	18.4	36.8	42.1
	Easy to access remotely	0	2.7	21.6	35.1	40.5
	Ease of using search tools	2.7	5.4	29.7	27.7	32.4
Availability or resources	Database	0	5.4	27.0	35.1	32.4
	E-books	0	10.5	26.3	34.2	28.9
	E-journals	5.1	7.7	15.4	43.6	28.2
	Software	2.8	16.7	36.1	22.2	22.2
Services	Time taken to connect & browse	0	5.3	23.7	44.7	26.3
	Easy to download and print	0	5.1	23.1	30.8	41.0

CONCLUSIONS AND RECOMMENDATIONS

This study was conducted to evaluate the online services provided by the APB library. The study was conducted over a period of one week and fifty-eight students, faculty and staff available in the library participated in the study. The respondents mentioned to have a good access to computer/internet and aware of the computer facilities in the library/department. They reported to use mobile devices (computers, tablets, mobiles) to access internet both at home and campus. The study revealed that most of the respondents were aware of the contribution of library towards improving their productivity and efficiency as well preparing them for future career.

Most of the participants were aware of the online library services and reported to access these services, both from campus and home. Fewer respondents, however, reported of not accessing online library, mainly because they were not informed, did not know how to use, and found it easier to work with printed materials. The study revealed some of the benefits of using e-library. The 24/7 and off-campus accessibility of resources was reported to be the major benefits of e-library. Ease of searching, downloading and sharing database/materials were also identified as other benefits of using e-library. The respondents mostly used e-library to: (i) access database, e-books and e-journals, (ii) complete class assignments/reports, and (iii) complete journal/conference papers. The study also observed the importance of e-library in various research activities. The respondents reported of using e-library to collect information, review and database relevant to research. The online services and resources of the APB library was observed to be satisfactory. The respondents were satisfied with the accessibility, ease of downloading and time required to connect and browse the online content using the APB online library. Few respondents were dissatisfied with the availability of the software and fewer respondents thought the current services to be outdated needing improvements.

In order to improve the effectiveness of the online services of the APB campus and increase the satisfaction of the users, the following recommendations can be drawn from the results of the study: (i) more training sessions are needed to increase information literacy among the users; (ii) continuous increment in the collection of online database, materials (e-books, e-journals) and academic software; (iii) increment and improvement of library spaces; and (iv) capacity building of library staff.

REFERENCES

- Abdallah, F., & Bilal, D. (2015). Exploring the Effectiveness of Library Services and Resources in Academic Libraries in Lebanon from Users' Perspectives. IFLA World Library and Information Congress, Cape Town, South Africa, August 2015.
- Adegun, A. I., Oyewumi, O. O., Oladapo, Y. O., & Sobalaje, A. J. (2015). Effectiveness of Library Services and Resources in an African University. *Information and Knowledge Management*, 5 (3), 54–59.
- Atakan, C., Atilgan, D., Bayram, O., & Arslantekin, S. (2008). An Evaluation of the Second Survey on Electronic Databases Usage at Ankara University Digital Library. *The Electronic Library*, 26 (2), 249 – 259.
- Ayob, A. (2011). An Assessment of the Effectiveness of Library Resources and Services in Supporting Researchers' Information Needs. National Seminar on Academic Library, Malaysia, 303 – 319.
- Boston University. (2013). Boston University 2013 Undergraduate Student Library Survey Report. Library Assessment Committee, Boston University, September 2013. Retrieved on December 10, 2016 from <http://www.bu.edu/library/files/2013/09/2013UndergradLibrary.pdf>
- Bradbury, R. (2016). UJ Library Annual Report 2015. Retrieved on December 10, 2016 from <https://www.uj.ac.za/library/Documents/LibraryAnnualreport2015web.pdf>
- Chrzastowski, T. E. (2011). Assessing the Value of Ebooks to Academic Libraries and Users. Proc. of the 9th Northumbria Intl. Conf. on Performance Measurement in Libraries and Information Services, ISBN: 9780901931115, University of York, UK, 53–61.
- Connaway, L. S., & Lawrence, S. R. (2003). Comparing Library Resources Allocations for the Paper and the Digital Library: An Exploratory Study. *D-Lib Magazine*, 9 (12). Retrieved on February 27, 2017 from <http://www.dlib.org/dlib/december03/connaway/12connaway.html>
- De Groot, S. L., & Dorsch, J. L. (2003). Measuring Use Patterns of Online Journals and Databases. *J. Med Libr Assoc*, 91 (2), 231 – 240.
- Jeng, J. (2005). Usability Assessment of Academic Digital Libraries: Effectiveness, Efficiency, Satisfaction and Learnability. *Libri*, 55, 96 – 121.
- Joo, S., Lin, S., & Lu, K. (2011). A Usability Evaluation Model for Academic Library Websites: Efficiency, Effectiveness and Learnability. *J. of Library and Information Studies*, 9 (2), 11 – 26.
- Khan, A. M. (2014). Measuring Effectiveness and Efficiency of an Academic Library's Collection and Services of the Central Library, Allahabad University: Users' Point of View. *International Information & Library Review*, 46 (1-2), 31 – 40.
- Lamprey, R. B. (2010). Promoting Effective Use of Library Resources and Services at Kwame Nkrumah University of Science and Technology Library, Kumasi, Ghana. *African Journals Online*, 22 (1-2), 87 – 99.
- Mery, Y., DeFrain, E., Kline, E., & Sult, L. (2014). Evaluating the Effectiveness of Tools for Online Database Instruction. *Communications in Information Literacy*, 8 (1), 70 – 81.
- Moll, M. (2011). The Impact of Information Literacy on the Pass Rate of First Year Students: A Project at the Cape Peninsula University of Technology. Proc. of the 9th Northumbria Intl. Conf. on Performance Measurement in Libraries and Information Services, ISBN: 9780901931115, University of York, UK, 297–303.
- Mulla, K. R., & Chandrashekar, M. (2009). A Study on the Effective Use of Online Public Access Catalogue at the Libraries of Engineering Colleges in Karnataka (India). *International Journal of Library and Information Science*, 1 (3), 29 – 49.
- Nkamnebe, E. C., Udem, O. K., & Nkamnebe, C. B. (2014). Evaluation of the Use of University Library Resources and Services by the Students of Paul University, Awka, Anambra State, Nigeria. *Library Philosophy and Practice* (e-journal), paper 1147.

Nok, G. (2006). The Challenges of Computerizing a University Library in Nigeria: The Case of Kashim Ibrahim Library, Ahmadu Bello University, Zaria. *Library Philosophy and Practice*, 8 (2).

Okite-Amughoro, F. A., Makgahela, L., & Bopape, S. (2014). The Use of Electronic Information Resources for Academic Research by Postgraduate Students at Delta State University, Abraka, Nigeria. *SA Jnl Libs and Info Sci*, 80 (2).

Sachs, D. E., Langan, K., Leatherman C. C., & Walters, J. L. (2013). Assessing the Effectiveness of Online Information Literacy Tutorials for Millennial Undergraduates. *College and Undergrate Libraries*, 20 (3-4), 327 – 351.

Sahin, Y. G., Balta, S., & Ercan, T. The Use of Internet Resources by University Students During Their Course Projects Elicitation: A Case Study. *The Turkish Online J. of Education Technology*, 9 (2), 234 – 244.

Stemmer, J. K., & Mahan, D. M. (2015). Assessing the Library's Influence on Freshman and Senior Level Outcomes with Users Survey. *Evidence Based Library and Information Pracitce*, 10.2, 8 – 20.

A CONCEPTUAL FRAMEWORK OF PERCEIVED EFFICIENCY OF CRM: CASE OF MOBILE PHONE OPERATORS IN TUNISIA

Nesrine Zouaoui Rejeb
University of Tunis El Manar, Tunisia

Chokri El Fidha
University of Tunis El Manar, Tunisia

Kaouther Zenaidi
Hail University, Kingdom of Saudi Arabia

ABSTRACT

The mobile telecommunication is a competitive sector. Operators propose a large number of promotions in order to attract new customers, what makes retaining their actual customers difficult. However, operators invest a huge amount on CRM and make relational and CRM efforts to retain their customers. The purpose of this paper is to suggest a conceptual framework that illustrates the impact of the CRM efforts provided by the operators on customer loyalty. In order to achieve our research objective, an exploratory study was carried out, based on a review of the literature and qualitative studies among mobile telecommunications professionals and customers. The results of this study made it possible to propose a conceptual framework that links the effectiveness of CRM with satisfaction and loyalty, where promotional sensitivity plays a moderating role on the relationship between the effectiveness of CRM and loyalty.

Keywords: Customer Relationship Management, Satisfaction, Loyalty, Promotional sensitivity, Mobile telecommunication.

INTRODUCTION

Building up, maintaining and developing a lasting relationship with customers is becoming a challenge for mobile phone operators in Tunisia. They are largely investing in relational strategies, in particular customer relationship management (CRM)¹. In spite of the numerous management-based studies measuring the efficiency of CRM (Reinartz et al., 2004; Ryals, 2005; Bohling et al., 2006; Chen et al, 2009; Jain et al., 2007; Jain and Bagdare, 2011; Padmavathy et al., 2012) very few attempted to measure perceived efficiency of CRM and determine its effect on customer behavior (Padmavathy et al., 2012). Jain, Jain and Dhar (2007) were the first to focus on this issue, underline the importance of developing customer-centered CRM measures. According to the literature, there are two measurement scales of the perceived efficiency of CRM. The first was proposed by Jain, Jain and Dhar (2007) and the second was developed by Padmavathy et al. (2012). Padmavathy et al. (2012) and Lacey and Kalaj (2015) tested the effect of perceived efficiency of CRM on satisfaction and loyalty. That's why; this study is interested to the efficiency of customer-centered CRM, focusing on its effect on customer behavior. Specifically, we try to understand the concept of perceived efficiency of CRM in the context of mobile phone industry in Tunisia. To this end, we adopt an abductive methodological approach. We first review the literature and develop a first conceptual

¹ See the results of the qualitative study

model summarizing the effects of perceived efficiency of CRM. This first model was enriched with a qualitative study of a sample of mobile phone professionals. This latter study revealed that the variable "sensitivity to promotions" qualifies as a moderating variable of the relationship between perceived efficiency of CRM and loyalty. To support the results of this study, we conducted a number of semi-directive interviews with a sample of consumers, in a second phase.

This paper is structured as follows. The first section conceptualizes the different concepts and relationships proposed by the literature. The second section reviews the relevant qualitative studies and their results. The final section presents our conceptual framework and proposes the relevant recommendations to improve perceived efficiency of CRM as a means of attracting and retaining customers.

CONCEPTUALIZATION OF CONCEPTS

In what follows, we present a theoretical framework conceptualizing the construct of perceived efficiency of CRM as well as its behavioral consequences as proposed in the literature.

Conceptualization of perceived efficiency of CRM

Measuring the efficiency of relational strategies is required for CRM to achieve its relational and financial objectives. The debate on measurement of its efficiency is still relevant. Indeed, Padmavathy and al.(2012) argue that the different proposed measures are inadequate. The most widely used measurement methods are, in fact, conventional methods. According to Parvatiyar and Sheth (2001), they are inappropriate to study CRM in given context and cannot assess investments whose expected benefits are, in the first place, intangible (Grembergen & Amelinck, 2002 in Kim et al., 2003). In response to these limitations, many researchers pointed to the importance of developing customer-centered measures that capture both tangible and intangible dimensions (such as customer satisfaction and loyalty) (Kim et al., 2003). In this sense, Jain, Jain and Dhar (2007) are the first researchers to have developed a measurement scale to assess efficiency of CRM in the service sector. They were followed by Padmavathy and al. (2012) who proposed a new five-dimensional scale of CRM efficiency applied to the banking sector. In fact, they support that CRM is contextual and it is necessary to develop a measurement scale of CRM perceived efficiency for each context. They also linked perceived efficiency of CRM with customer satisfaction and loyalty. Lacey and Kalaj (2015) applied this model in the context of tour operators in Albania. They used their measurement scale, even if it has been developed for the banking sector. Accordingly to Padmavathy and al (2012), they also conclude that the CRM perceived efficiency impacts customer loyalty and satisfaction. Relationship-oriented marketing and CRM are tools adopted by companies to achieve a set of goals and improve their performance. Among these objectives, we mention customer attitude and behavior improvement, the guarantors of firm performance. The next section presents the relational and behavioral variables, which, according to the previous literature, can be influenced by the companies relational and CRM practices.

Conceptualization of the outcomes of perceived efficiency of CRM

Few studies have compared perceived efficiency of CRM, integrating behavioral variables. However, the goal behind any relational marketing strategy is improving business profitability. According to Anderson and Mittal (2000), this profitability cannot be real without reaching some relational effects on customers. The literature reports that customer satisfaction and loyalty remain the main relational outcomes that the company aims to achieve. Moreover, Padmavathy and al.(2012) approach the fact that the previous studies of CRM efficiency did not address issues of its contribution to customer benefits and the company's relational performance.

Satisfaction

Satisfaction with a relationship is often considered the pillar concept to analyze a customer's post-purchase behavior. It is often viewed as an important outcome of the customer-business relationship (DeWulf et al., 2001). Indeed, as

long as the customer is satisfied, the company can maintain a certain level of profitability out of this relationship (Halimi et al, 2011).

CRM is a relational marketing tool. It represents the relational efforts of the company. Mithas et al (2005) argue that CRM efforts enable the company to collect customer information through varied and customized interactions. Thus, companies will be able improve the offer to meet customers' needs and expectations which in turn improves perception of service quality and affects customer satisfaction. Similarly, according to Palmatier et al (2006), some other authors believe that maintaining a relationship with some customers is not advantageous for the company because their maintenance cost is higher than the profit generated. A satisfied customer is more likely to be loyal to the same company (Anderson and Narus, 1990). This positive relationship between satisfaction and loyalty has been validated by several researchers in different fields (Padmavathy, Bajli and Sirakumar, 2012). Padmavathy, Balaji and Sirakumar (2012), afterwards Lacej and Kalaj (2015) proved that perceived efficiency of CRM has a positive impact on customer satisfaction.

Loyalty

When customer behavior and relational marketing are put into focus, loyalty emerges as one of the most important relevant concepts (De Cannière et al., 2010). Interest in loyalty relates to the assumption that every loyal customer is profitable (Gupta et al, 2004). However, research on the impact of perceived efficiency of CRM on loyalty remains scarce. Yet, customer loyalty is one of the most anticipated results of CRM strategies. These strategies lead to a strong customer relationship and customer loyalty (Palmatier et al., 2006). In general, Palmatier et al (2006) state that relational strategies positively affect on relational outcomes. Padmavathy, Balaji and Sirakumar (2012) and Lacej and Kalaj (2015) show that perceived efficiency of CRM positively affects loyalty.

So far, we have introduced the key concepts representing perceived efficiency of CRM. An efficiency that mainly goes through customer behavior, in particular their satisfaction and loyalty, dimensions considered as pillars for the success of the company's relational strategy.

In what follows, we present our qualitative study conducted to better understand perceived efficiency of CRM and its impact on customer behavior in the mobile phone sector.

RESEARCH METHODOLOGY

Because of the very few studies of perceived efficiency of CRM, and our willingness to develop a comprehensive conceptual framework, we thought it useful to conduct an exploratory study of a sample of mobile phone industry professionals followed by another on customers. Conducting first an interviews-based qualitative study with professionals is motivated by the desire to understand the CRM strategies and actions deployed by the studied phone operators and to determine later their expected outcomes. These interviews mainly aim at:

- Identifying the CRM efforts that should be made by the operator for its customers so that CRM is efficient and reaches its objectives.
- Defining the outcomes expected by the operators following the deployment of CRM efforts for customers.
- Determining whether it is necessary to develop a new measurement scale of perceived efficiency of CRM for the mobile telephony context, as postulated by Padmavathy, Balaji and Sirakumar (2012).
- Determining the possible dimensions that may influence the impact of perceived efficiency of CRM.

The aim of the qualitative consumer survey is to further support the results of the interviews with mobile phone professionals such as: Identifying if the "sensitivity to promotions" would be mentioned as an attitudinal variable that can impact the relationship between perceived efficiency of CRM and loyalty.

Profiles of the surveyed professionals and consumers:

A total of 11 in-depth semi-directive interviews were conducted with marketing and CRM managers working for the three mobile phone operators in Tunisia; Ooredoo, Tunisie Télécom and Orange Tunisie. Each interview lasted more than one hour. Respondents were asked to describe what operators should do to ensure that customers perceive their CRM efforts as efficient. They were also asked to explain what behavior customers should show in order to estimate that CRM is efficient.

Ten semi-directive interviews are conducted with Tunisian customers owning mobile phone chips issued by the studied operators. The sample is heterogeneous, consisting mainly of young people and adults. Their ages varies between 20 and 40 years and have different professional activities. They spend about 5 and 30 DNT on mobile communications. They are considered, by professionals, as "low value" and "middle value" customers. Consumers were asked to describe their experiences with their operators. They were also asked to list all the dimensions that allow them to keep in touch with their operators as well as the reasons that may push them to switch towards competitors. The average length of the interview is about 45 minutes. The results of the analysis of interviews with professionals and consumers are reported in the following section.

RESULTS OF THE QUALITATIVE STUDIES

We used a content analysis to interpret the results obtained for the qualitative study of both professionals and customers, in line with the approach proposed by Gianelloni and Vernet (2001). The content analysis revealed the following themes mentioned by professionals and customers:

- The dimensions of perceived efficiency of CRM,
- The outcomes of perceived efficiency of CRM,
- The dimensions that influence the impact of perceived efficiency of CRM.

Dimensions of perceived efficiency of CRM

The interviewed professional described perceived efficiency of CRM as a set of actions and processes that the operator undertakes to build customer loyalty. Customers described perceived efficiency of CRM as a set of actions and dimensions that the operator should undertake to retain them. Analysis of the two qualitative studies indicated that the following dimensions should be considered in order for CRM to be perceived efficient.

- Customer Orientation (cited 68 times by professionals and 25 times by customers): all professionals and customers indicated that customer orientation primarily rests on customer focus. Moreover, we noticed that customer orientation is not a priority for customers. The literature also points the importance of adopting customer orientation to reach an efficient CRM (Jain et al., 2007, Jain and Bagdare, 2011 and Padmavathy, Balaji and Sirakumar, 2012).
- Employees' adequate behavior (cited 32 times by professionals and 24 times by consumers): Professionals pointed out that employee behavior and attitude when interacting with customers indicates CRM efficiency. Customers, on the other hand, feel it is important that staffs are good listeners, friendly and welcoming. Indeed, employees are the main ambassador of the firm (Alcouffe et al., 2000).
- Responsiveness to complaints and managing customer problems (cited 26 times by professionals and 53 times by customers): Professionals pointed to the importance of effectively handling complaints during the interviews.
- Customization of products and services (cited 25 times by professionals and 17 times by customers) or CRM efficiency in a rather "tangible" way for the professionals. Customers, on the other hand, indicated that it is not enough to retain them. Researchers like Jain, Jain and Dhar (2007) and Jain and Bagdare, (2011) identify customization as an important component of perceived efficiency of CRM.
- Concern for the customer (cited 18 times by professionals and 37 times by customers). One aspect of an efficient CRM for customers is the company's concern shown for them (Jain, Jain and Dhar, 2007). The interviewed professionals indicated that concern for the customer is a factor behind the success of CRM. Customers share the same view. Moreover, this factor is the most cited after responsiveness.

- Technology Orientation of the company (cited 17 times by professionals and 33 times by customers). Technology is paramount to any CRM process. The interviewed customers, on the other hand, showed a particular attention to the technologies used by operators and their importance, young people showed the highest attention to this factor. Previous research on perceived efficiency of CRM focuses on technology use as one of the dimensions determining this concept (Jain et al., 2007, Jain and Bagdare, 2011, Padmavathy, Balaji and Sirakumar., 2012).

The table 1 shows the different dimensions of perceived efficiency of CRM cited in the literature and those determined by the interviewed professionals and customers. In the table 1, we notice that the interviewed professionals mentioned most of the dimensions of perceived efficiency of CRM. Compared to Jain, Jain and Dhar (2007), only the dimensions "ethical practices" and "customer promotions" are not mentioned. Both professionals and customers mentioned the same dimensions of perceived efficiency of CRM. This results shows that the scale developed by Jain, Jain and Dhar (2007) is adapted to the Tunisian context.

Table 1: Dimensions of CRM efficiency cited in the literature Vs dimensions cited by professionals and customers

Jain, Jain and Dhar (2007)	Jain and Bagdare (2012)	Padmavathy, Balaji and Sirakumar (2012)	Our professionals and customers
Dimensions	Dimensions	Dimensions	Dimensions
Responsiveness	Responsiveness	Customer experience	Responsiveness
Concern for customers	Relationship-oriented	Process-oriented approach	Concern for customers
Customer Orientation	Customer Orientation	Organizational commitment	Customer-centeredness
Technology Orientation	Coherence	Technology Orientation	Technology Orientation
Personal touch	Customization		Customization
Humility	Humility		Employees behavior
Ethical practices	Reliability	Reliability	
Customer promotions	Favors		

However, we noticed that for customers that interest in one factor or the other varies with age. Indeed, young people focused more on technology orientation of the operator. Adults are interested in service quality and, above all, in the responsiveness shown by the operator.

Outcomes of perceived efficiency of CRM

The qualitative studies of professionals and customers showed that customer satisfaction and loyalty are the two main outcomes that an efficient CRM seeks to reach. Loyalty emerges as the main expected impact of perceived efficiency of CRM (cited 50 times by professionals and 27 times by customers), Interviewed professionals insist that customer loyalty is the ultimate goal of any company having adopted a CRM strategy. Similarly, researchers admit that loyalty remains the most expected result of the company's relational and CRM efforts (Anderson and Mittal, 2000, Jain and Bagdare, 2011, Padmavathy and I, 2012). Satisfaction is also cited as an important result of an efficient CRM (cited 6 times by professionals and 17 times by customers). Even if it is not cited much by professionals, compared loyalty, customers said that they are willing to be loyal to their operators if they are satisfied (see Appendices 1, 2 and 3). The literature on relational marketing states that satisfaction depends on the relational efforts provided by firms and that it in turn leads to loyalty (De Wulf et al., 2001, Morgan and Hunt 1994, Palmatier et al., 2006 Jain and Bagdare, 2011). There are few studies link perceived efficiency of CRM with the main behavioral responses of customers. Padmavathy, Balaji and Sirakumar (2012) are the only authors who studied this relationship. However, in spite of the numerous studies of CRM, researchers are still calling for a better understanding of the impact of CRM on key customer responses such as satisfaction and loyalty (Boulding et al., 2005 , Padmavathy, Balaji and Sirakumar, 2012).

Dimensions that influence the effect of perceived efficiency of CRM on loyalty

The interviewed professionals spontaneously pointed to a dimension specific to Tunisian customers and which sometimes prevents them from retaining them. This is labelled “sensitivity to promotions” (cited 44 times by customers). The effect of sensitivity to promotions on customer loyalty is cited 50 times by professionals. The objective of the in-depth interviews with customers was to unveil variables specific to customers. Indeed, customers cited attraction to promotions (cited 48 times) as one of the main reasons for acquiring a second phone chip or switching to another mobile operator. Some customers claimed they were ready to change their operator, in spite of all its relational efforts, in order to benefit from a more favorable promotion offered by a competitor.

At the literature level, sensitivity to promotions is defined as *“The degree to which a customer is influenced by a promotion, for a given purchase opportunity, of a given product class and with a given promotional technique”* (Froloff-Brouche, 1994). Research, on “sensitivity to promotions” shows that it negatively affects customer loyalty (Froloff, 1992), and leads to brand / store switching behavior (Froloff-Brouche, 1994). Indeed, “sensitivity to promotions” is a concept centered on influence. This influence manifests itself concretely in behavior (Blattberg and Neslin, 1990) and in the psychological processes that preceded the purchase act (Froloff, 1992).

Main results of the interviews and a proposal of a conceptual model

Our previous analysis enabled us to better understand the concept of perceived efficiency of CRM in the mobile phone sector in Tunisia. With reference to the literature and our content analysis above, in Figure 1 we present a conceptual model that integrates the main relationships resulting from our exploratory study.

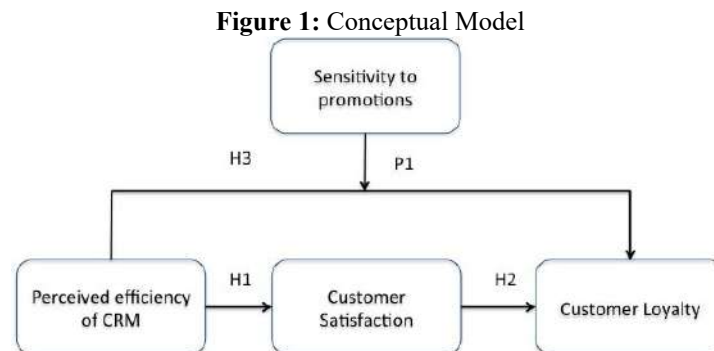

As shown in Fig. 1, a CRM perceived efficient by customers can lead to customer satisfaction and loyalty. Satisfaction is a factor influencing loyalty (Palmatier et al., 2006) and plays the role of a mediator between perceived efficiency of CRM and loyalty (Padmavathy, Balaji and Sirakumar., 2012). Padmavathy, Balaji and Sirakumar (2012), afterwards Lacey and Kalaj (2015) are the only ones who have studied these relationships. These two studies conclude a strong positive relationship between the perceived efficiency of CRM and customer satisfaction and loyalty. Relating to these findings, we can state the following hypotheses:

H1: The perceived efficiency of CRM has a positive effect on customer satisfaction.

H2: The satisfaction positively impacts customer loyalty.

H3: The perceived efficiency of CRM has a positive effect on customer loyalty

According to the interviewed professionals, mobile phone sector in Tunisia is one of the most dynamic in terms of promotions. Mobile operators often launch promotions, as charging bonuses, which attract more and more customers. The interviewed professionals indicated that the Tunisian customer is highly sensitive to promotions. Most surveyed customers don't deny their attraction to promotions and admit they are willing to switch operators if any competitor proposes a better promotion, despite the relational efforts made to retain them. Admittedly, in the

literature, “sensitivity to promotions” has been linked to a set of behavioral and attitudinal variables such as loyalty or purchase intention, but it has often been studied as an independent variable (Laure et al, 2014). According to the thematic analysis, some customers are sensitive to promotions, others are not. Customers who are sensitive to promotions are the least loyal, which is consistent with the relevant literature (Frolof-Brouche, 1994). To better understand how « sensitivity to promotions » impacts the relationships between perceived efficiency of CRM and customer loyalty, we propose to study it as a moderator of this relationship and state the following proposition.

P1: More the customer is sensitive to promotions, lower is the effect of CRM' perceived efficiency on loyalty.

CONCLUSION

The mobile phone sector in Tunisia is a very competitive sector. In order to understand the impact of perceived efficiency of CRM on consumer behavior, we tried to propose a conceptual model made possible through conducting qualitative studies on professionals and customers. The study on professionals was carried out first. To support the results of this first study, we decided to conduct a second qualitative study on customers.

The qualitative study of professionals shows that Tunisian mobile phone operators aim mainly to increase their customers' loyalty by implementing specific customer-oriented CRM actions. The results of the customers study identified responsiveness as the main determinant of perceived efficiency of CRM. We were also able to identify Tunisian customers' sensitivity to promotions as a real problem for the operators. Indeed, customers who are sensitive to promotions, called “opportunists” by professionals, are difficult to retain despite the CRM efforts made by operators. This is also observable in the customer survey. Indeed, some customers said they are ready to switch to another competitor if this latter offers better promotions. This study was able to identify the main factors behind CRM efficiency, from operational and strategic point of views. Factors such as “Customer orientation” and “employee behavior” followed by “responsiveness to complaint” and “concern for the customer” should be taken into account and improved by the operators to insure an efficient CRM.

This study is a contribution to the CRM literature and mainly customers' perceived efficiency of CRM. This latter construct still remains at an embryonic stage compared to the abundant literature on CRM and its efficiency measurement at the company level. It also emphasizes the role played by attitudinal variables in the CRM success. Thereby, we proposed a conceptual model specific to the Tunisian context that incorporates the variable "sensitivity to promotions" as a variable moderating the relationship between perceived efficiency of CRM and loyalty

Like in any study, ours has some limitations. Firstly, in terms of content analysis, we didn't focus on identifying characteristics of customers who are sensitive to promotions. The customers' sample size is also a limit. Future studies can, by questioning a larger sample, would study this variable in depth, and provide clear and complete information about this customers type. Secondly, we was limited ourselves to an exploratory study. We believe that a confirmatory study is necessary to validate our conceptual model. Finally, this study looked only at the mobile phone sector in Tunisia. It would be enriching to study other contexts that may integrate other variables that can be taken into account.

REFERENCES

- Anderson, E, & Mittal, V, 2000, Strengthening the Satisfaction-Profit Chain, *Journal of Service Research*, 3: 107
- Anderson. J. C., & Narus. J.A., 1990, "A Model of Distributor Firm and Manufacturer Firm Working Relationships." *Journal of Marketing*. 54(I).42-58.

- Blattberg, R., & Neslin, S., 1990, Sales Promotions : Concepts, Methods and Strategies, Englewood Cliffs, New Jersey, Prentice Hall, cité dans Froloff, L (1992), la sensibilité du consommateur à la promotion : de la naissance à la maturité, *Recherche et Applications en Marketing*, vol VII, N 3/92, 69-88
- Boulding, W., Staelin, R., Ehret, M., & Johnston, W.J., 2005, A customer relationship management roadmap: What is known, potential pitfalls, and where to go, *Journal of Marketing*, 69 : 4, 155-68.
- Chen, Ja-Shen, Yen, H.J. Rebecca, Li, Eldon Y., & Ching, Russell K.H., 2009, Measuring CRM effectiveness: Construct development, validation and application of a process-oriented model, *Total Quality Management, and Business Excellence*, 20: 3, 283–299
- De Cannière, M.H, De Pelsmacker, P., & Geuens, M., 2010, Relationship Quality and Purchase Intention and Behavior: The Moderating Impact of Relationship Strength, *Journal of Business and Psychology*, 25:1, 87-98.
- De Wulf, K, Gaby Odekerken-Schrocler, G., & Iacobucci, D., 2001, Investments in Consumer Relationships: A Cross-Country and Cross-Industry Exploration, *Journal of Marketing* Vol. 65, 33-50
- Froloff-Brouche, L. 1994. L'influence de la promotion des ventes sur le consommateur : un essai de conceptualisation. *Recherche et Applications en Marketing*, 9, 3, 45-65.
- Froloff, L 1992, la sensibilité du consommateur à la promotion : de la naissance à la maturité, *Recherche et Applications en Marketing*, vol VII, N 3/92, 69-88
- Giallonni, J.L et Vernet, E., 2001, « Etudes de marché », Editions Vuibert, Paris.
- Gupta, S, Lehmann, D.R., & Ames, J., 2004. Valuing Customers^[1], *Journal of Marketing Research*, Vol. 41, No. 1, pp. 7-18
- Halimi, A.B, Chavosh, A, Namdar, J, Espahbodi, S, & Esferjani, 2011, The Contribution of Personalization to Customers' Loyalty Across the Bank Industry in Sweden, *International Conference on Social Science and Humanity IPEDR* vol.5, IACSIT Press, Singapore.
- Jain, R., & Bagdare, S., 2011, « CRM in Retailing: A Behavioural Perspective », *Journal of Marketing & Communication* September - December 2011 Vol. 7 Issue 2
- Jain, R., Jain, S., & Dhar, U., 2007, « CUREL : A scale for measuring customer relationship management effectiveness in service sector, *Journal of Services Research*, 7 : 1.
- Kim, J., Suh, E. & Hwang, H. 2003, A model for evaluating the effectiveness of CRM using the balanced scorecard, *Journal of interactive Marketing*, 17: 2, 5-19
- Lacej A. et Kalaj E.H. (2015), The Effect of Consumer Relationship Management on Satisfaction and Loyalty: A Focus on Albanian Tour Operator Business, *Mediterranean Journal of Social Sciences*, 6, 2, 635 – 642
- Laure, F.N.H., Victor, T., & Nwamen, F., 2014, « Offres promotionnelles et sensibilité du consommateur à la promotion des ventes », *International Journal of Innovation and Applied Studies* ISSN 2028-9324 Vol. 9 No. 3 Nov. 2014, pp. 1392-1400
- Mithas, S, Krishnan, M.S. & Fornell, C. 2005, Why Do Customer Relationship Management Applications Affect Customer Satisfaction? *Journal of Marketing* Vol. 69, 201–209
- Morgan, M.R., & Hunt, C-D, 1994, « The Commitment-Trust Theory of Relationship Marketing », *Journal of Marketing*, Vol. 58, No. 3, pp. 20-38

Padmavathy, C., Balaji, M.S. & Sivakumar, V.J, 2012, Measuring effectiveness of customer relationship management in Indian retail banks, *International Journal of Bank Marketing*, 30: 4, 246-266.

Palmatier, R.W, Dant, R.P, Grewal, D, & Evans, K.R, 2006, Factors Influencing the Effectiveness of Relationship Marketing: A Meta-Analysis, *Journal of Marketing* Vol. 70, 136–153.

Parvatiyar, A., & Sheth, J.N., 2001, « Customer Relationship Management: Emerging Practice, Process, and Discipline », *Journal of Economic and Social Research* 3(2) 2001, 1-34

Reinartz W., Krafft M & Hoyer W.D., (2004), The Customer Relationship Management Process : Its measurement and impact on performance, *Journal of Marketing Research*, Vol. XLI, 293-305.

Reinartz, W.J & Kumar, V, 2000, On the Profitability of Long-life Customers in a Noncontractual Setting : An Empirical Investigation and Implications for Marketing, *Journal of Marketing*, 64, 17-35.

Ryals L., (2005), Making Customer Relationship Management Work: The Measurement and Profitable Management of Customer Relationships, *Journal of Marketing* Vol. 69 (October 2005), 252–261

Souhail, M.S, 2012. The Antecedents of Relationship Marketing and Customer Loyalty: A Conceptual Framework to Determine Outcomes, International Conference on Economics, Business Innovation IPEDR vol.38, IACSIT Press, Singapore.

Zablah, A.R., Bellenger, D.N., & Johnston, W.J., 2004, «An evaluation of divergent perspectives on customer relationship management: Towards a common understanding of an emerging phenomenon, *Industrial Marketing Management* 33 (2004) 475–489.

TRACKING A LION IN THE JUNGLE: TRENDS AND CHALLENGES IN OUTDOOR ADVERTISING AUDIENCE MEASUREMENT

Thérèse Roux
Tshwane University of Technology

ABSTRACT

Research addressing developments in traditional media such as outdoor advertising over the last several years has become quite small. This paper explore the trends, challenges and practices in outdoor advertising audience measurement from a developing country perspective. Qualitative interviews with experienced practitioners that serve some of the leaders in out-of-home advertising expenditure were conducted. Major barriers in the industry are concerns regarding the neutrality and fragmentation of outdoor advertising audience measurement. The likelihood to see a particular advertising face on a board is calculated by assessing the opportunity to see it and the visibility index of each individual outdoor advertising board in an area. Results provide justification for future research in the area. In an era of highly mobile consumers, accurate outdoor advertising audience measurement systems are essential planning information for advertisers and their agencies to leverage their investments.

Keywords: Outdoor advertising, Out-of-home advertising, audience measurement.

INTRODUCTION

“If you want to understand how a lion hunts, don’t go to the zoo. Go to the jungle.” (Stengel, n.d.). Outdoor advertising exposure and processing does not happen in an organised contrived indoor setting, but is part of consumers’ everyday life when they leave their homes to work, shop, socialise and travel. Consumers’ processing of outdoor advertising therefore depends on the strategic placement outdoors, the level of exposure and frequency as well as the creative execution of the message (Bhargava, Donthu & Caron, 1994; Donthu, Cherian & Bhargava, 1993; Van Meurs & Aristoff, 2009). To have an effect on message processing a consumer driving past an outdoor advertising board must first have the opportunity to see (OTS) the particular advertising face, which requires the board to be conspicuous enough (Wilson, Baack & Till 2015; Wilson & Casper 2016). The focus of this article is on audience measurement of outdoor advertising when planning campaigns in South Africa.

The growth of outdoor advertising in Africa is substantial; e.g. the markets in Kenyan and Nigerian increased with more than 200% from 2008 to 2012 (Price Waterhouse Coopers 2013). These spectacular growth rates have slowed down, but consistent growth is predicted to continue the next five years. Nigeria was worth US\$181 million in 2015 but will become the fastest-growing market with a CAGR of 7.8% representing US\$263 million in 2020. Kenya is predicted to be the second-fastest market over the forecast period, growing at a compound annual growth rate of 7.0% from US\$ 98 million in 2015 to US\$138 million in revenue (Price Waterhouse Coopers 2016). Growth in Sub-Saharan Africa is being driven by a number of factors: real rapid rates of urbanisation, larger audiences of international travellers and regular commuters due to the rise in termini offered by international and national airlines and car ownership rates; high penetration and visibility; improved literateness among the population and investments by large international and local media companies (Continental outdoor, 2017; Ornico, 2017; Primedia outdoor, 2017). However, the out of home (OOH) industry in Africa faces some major challenges such as the lack of effective verification of audience sizes, traffic count data and available inventory, increasingly strict but also inconsistent regulation and legislation across states and even touts in rural areas demanding fees to allow the changing of advertisements or structures (Price Waterhouse Coopers, 2013).

Consumers spend significantly more time traveling between home and work, due to traffic congestion and distances travelled. South Africans spend more than an hour each day commuting, compared with the 45 minutes spent by commuters in the United Kingdom, 44 minutes in Germany, and 43 minutes in the Netherlands (World Bank in Price Waterhouse Coopers, 2016). The increased time spent outside homes in the open air, whether for recreation or simply commuting from one place to another, presents an opportunity for advertisers to reach this mobile audience.

However according to Nielsen, traditional OOH advertising media types such as roadside billboards accounted for only 4% of the total of advertising media investment in South Africa (OMD 2016). OOH advertising is therefore often referred to as the 'Cinderella media' in South Africa, due to the untapped potential (Patterson, 2011).

PROBLEM STATEMENT AND OBJECTIVES

OOH advertising also seems to be the stepchild in scholarly literature. Empirical research in South Africa is very limited and focuses predominantly on the regulation of outdoor advertising of harmful products (De Bruijin, Ferreira-Borges, Engels, & Bhavsar, 2014) or the promotion of public health campaigns (Nagel & Louw, 2004). Some prominent international researchers coupled with the industry to enact field experiments and surveys across a large territory and on a national scale to study this medium (Donthu & Bhargava, 1999; Bhargava, Donthu & Caron, 1994).

Only a few studies investigated recent developments in OOH advertising media such as the introduction of digital signage (Dennis, Newman, Michon, Brakus & Wright 2010; Burke 2009) and computational neuroscience software programmes and eye-tracking measuring the processing of outdoor advertising messages (Wilson, Baack & Till 2015; Wilson & Casper 2016).

International academic and empirical research focus predominately on the quantifying of audiences of new media such as the Internet, mobile advertising and social media (Knoll, 2015) and digital television (Carey, 2016), but lose sight of the fact that other media are attempting to find innovative solutions to cope with and thrive in the contemporary media environment (Taylor, 2015).

However very little is known on how the cover and frequency delivered by outdoor advertising is or should be assessed (Bloom, 2000). There still is a lack of understanding of audience measurement systems used by the industry to plan and evaluate OOH advertising media (Taylor, 2015). A notable exception is the article by Bloom (2000), though it offers an historical perspective on practices in developed countries rather than empirical research with practitioners who directly deal with the complexity and challenges of OOH advertising audience measurement in a developing context.

In the light of the above discussion the purpose of this article is *to explore the trends, challenges and practices in outdoor advertising audience measurement in South Africa.*

The measuring outdoor advertising will be discussed in the following sections. This will be followed by the research methods and insight obtained in-depth interviews with purposively selected professionals in the industry. Then a process for outdoor advertising audience measurement is outlined, followed by the managerial implications and suggestions for future research.

MEASURING OUTDOOR ADVERTISING AUDIENCES

Outdoor advertising media are usually placed in the roadside environment, targeting fast-moving vehicular traffic on highways and other major roads. Consequently, an important condition for the effectiveness of outdoor advertising

media is visibility or opportunity to be seen from the side of a road (Taylor, Franke and Bang 2006). This allows readable and concise messages to be noticed by motorists and passengers (Donthu, Cherian and Bhargava 1993).

Determining the weight of outdoor advertising campaigns are not standardised, because measuring or verifying audience data is a complex issue and varies considerably between countries (Bloom 2000). In some countries OOH media attract a relative small share of the overall advertising expenditure out of which those who own or rent the media space have to find the money needed to fund this research. This implies that there are relatively little funds available to conduct costly and technological advanced research, so media providers just manually keep records of the available boards per city (Price Waterhouse Coopers 2013). Developed countries with more resources combine innovative geo-targeting and eye tracking technologies; circulation and traffic survey data into one rating system to accurately measure and plan the likelihood of targeted audience noticing campaigns (Traffic Audit Bureau, 2016).

There are some unique problems associated with measuring advertising effects in an OOH environment: incidental exposure to this type of advertising (Wilson, Baack & Till, 2015), lack of content accompanying the advertisement that could be used to define the demographics of the audience (Wilson & Till, 2008), measurement in terms of people passing a board as opposed to measuring people who actually noticed the advertisement (Bloom, 2000).

STUDY DESIGN AND PROCEDURE

An inductive approach to qualitative content analysis, where the researcher starts with an area of study and allows the themes to become visible from the data was applied as research method (Patton, 2005). It facilitated thorough and nuanced descriptions of the themes within the data and generated new insights on outdoor advertising audience measurement in South Africa.

Purposive sampling was applied to select specialists in prominent media agencies in South Africa. The directors at the agencies were briefed on the purpose of this research and asked to suggest the most suitable people in their company to participate in the study. This resulted in ten participants with extensive experience in audience measurement systems used to plan and evaluate outdoor advertising campaigns.

The participants were interviewed in-depth using an interview guide which moved from general to specific questions to provide context for each participants' responses and allow the dialogue to develop based on perspective of the participant (Denzin & Lincoln, 2005).

The interviews were transcribed verbatim and checked for accuracy based on the actual recordings. Then coding took place in multiple stages with the help of ATLAS.ti qualitative software analysis. This was done to identify where the results supported literature and where it could claim unique contributions.

Come common practices to achieve rigor in qualitative research as suggested by Lincoln and Guba (1985) were applied in the current study.

FINDINGS

The trends, challenges and practices as mentioned by experts are reported. After each piece of evidence the source of information is indicated by providing the participant number, e.g. (P1)

Trends and challenges in outdoor advertising audience measurement:

In the past there has been a number of industry-driven attempts by the professional bodies, such as the OOH Media association of South Africa and the South African Research (SAARF) foundation, as well as some of the larger media owners to rectify the problem of the lack of an objective measurement system. Because there seems to be no solution that is acceptable to all the role-players in the industry, the quest is still continuing.

“That is why I want to do the other research (project) with SARF or the Cuende guys (Info-metrics specialists in the development of global audience measurement systems), so that you’ve got more of an idea of who the moving outdoor audiences are. It’s not just residential data” (P1).

The findings revealed a number of potential obstacles to accountable and measurable OOH advertising campaigns in South Africa. Media planners perceived OOH advertising planning to be complex due and lacking reliable audience research guiding their decisions.

“It takes a lot of time and effort to plan outdoor, and outdoor can’t be planned or brought from sitting behind your desk, you need to get into your car, and actually drive around in order to buy quality outdoor. You need to do that regularly because it changes all the time. And media planners don’t like that, they would rather sit with a cup of tea and press the button on the amps module ”(P2).

At this stage there is still no objective and standardised audience measurement system used by advertisers, OOH advertising media planners and companies. This is experienced as a major obstacle when planning campaigns and hinders the calculation of media weights required to accomplish specific objectives.

“We do not have the tools in place just yet to say how many GRPs (Gross Rating Points) or ARs (Audience Ratings) or whatever rating currency you wish to use, each campaign delivers. I hope that they get in place ... and then it will be a whole different story” (P9). This is in strong contrast to the technological advanced integrated systems in developed markets (Clear channel international, 2016; OMA Australia, 2016; Traffic Audit Bureau, 2016).

In South Africa the industry is still highly fragmented with media agencies, advertisers and media companies working in silos. The leading media companies developed their own outdoor advertising audience measurement system to grade the outdoor advertising boards they sell. These companies are accused by the media agencies of using the results – primarily as a tool to promote the specific media they offer; and therefore, they were not to be trusted.

“The figures are quite simply not believable. You know, if you had to lend out your ears to all kinds of research that is getting done, it is not going to happen. Basically, the thing is that I find media owner research interesting. I don’t always take it as gospel truth, because a media owner has a specific agenda to promote and wants to sell stock, which is understandable; and he is going to present you with the facts that make the most sense to promote his specific offer” (P10).

The lack of neutrality of audience figures and resources to conduct the costly and technological advanced research represent a major threat for advertisers and media planners. This can be addressed if all the stakeholders in the industry work together rather than in silos. Independent-governing bodies adhering to standardised international practices are responsible for the audience measurement systems in developed markets. They have evolved from originally only measuring outdoor advertising audiences to include other OOH platforms such as transit media advertising, street furniture and retail advertising (Clear channel international, 2016).

The complexity and the high cost involved in measuring the effectiveness of OOH advertising campaigns aimed at mobile vehicular audience is prohibitive. Only large business with sizeable advertising budgets request post-campaign research. In order to determine the effect of a campaign, both pre-and post-testing of a large representative sample of the target audience are necessary (Donthu & Bhargava, 1999; Bloom, 2000). This typically involves independent research companies to conduct two separate surveys, with a large sample of participants, which is a costly and time-consuming activity, when dealing with a mostly mobile and widely distributed audience. As anticipated, this research is usually only commissioned by large companies with sufficient financial resources available.

“We mostly do post-campaign analysis; but it is hard to prove that people are now more aware of the product than before. The analysis is mainly based on added value, extra exposure, if there were free gifts given. But

in terms of proving that before your campaign, 60% of South Africans knew about your brands, and now 70% know about it, you can't. Unless you do a massive survey, but that would just cost a lot of money" (P3).

The OOH advertising media, used in the longer term are far more difficult to measure than tactical campaigns aimed at obtaining behaviour in the short term only. While the short-term effect on sales can be measured to an extent, the longer-lasting effect of a campaign cannot be determined that simply (Vakratsas & Ambler, 1999). It is possible to monitor short-term responses to advertising or spikes in sales; but gains, such as the increased awareness and branding spin-offs, are not currently measurable.

"The effectiveness of OOH advertising media campaigns depends on what you advertise and it depends on what you wanted to achieve. Sometimes, there is a collaborative spike in consumption of the product that you advertise. Sometimes, it can be actually measured." (P10)

Practices in outdoor advertising audience measurement

The participants acknowledged that verifying the size and demographics of a mobile audience exposed to a wide variety of media - each with unique features and placed at different locations and in different environments across the country are complex.

'This process is more complex nowadays because there are so many types of media available. It's so broad now, yes and the audience is moving' (P1). OOH media companies constantly develop new formats and find new locations in which to place them. These factors create a constant challenge to audience measurement.

The participants have indicated their involvement in the development of proprietary software applications used for outdoor advertising audience measurement and planning. Since these planning tools are regarded as unique they are presented to advertisers as the strength of the media agency, to offer them a competitive advantage in the market.

Some even claimed, *'the tools we use are one of a kind. No other company has taken the time and money to develop the tools that we have' (P4). Consequently, these tools are not shared for public use; and each agency uses their own tools – in an attempt to differentiate themselves from their competitors in the market.*

These applications can only be applied to outdoor advertising boards and cannot be used when planning across other OOH platforms such as mall media and transit advertising. South Africa is thus less advanced compared to global measurement systems in developing countries used to plan campaigns across platforms (Clear channel international, 2016).

Proprietary software-planning tools are used to indicate the likelihood to see (LTS) a particular advertising face on a board. This is calculated by assessing the opportunity to see (OTS) a particular advertising face on a board and the visibility index (VI) of each individual outdoor advertising board in an area ($OTS \times VI = LTS$).

The likelihood of seeing a free-standing outdoor advertising board in the roadside is calculated by considering factors influencing the visibility, such as its size, design, orientation to the road, surrounding distractions, and whether or not it is illuminated (Table 1).

Table 1: Factors influencing the likelihood of seeing freestanding outdoor advertising boards

	OOH environment
	Factors
Physical characteristics	Relative size and format Extent of illumination The viewing angle or orientation of the board to the road The competitive environment and visual stimuli
Interaction with the audience	Potential viewing time, based on the traffic flow or congestion The general condition and design of the structure

Quality control is essential when the modelling based on the visibility index is treated as proprietary intellectual property by developers. There can be a large variation in application of the model and the quality of the input data. Therefore the process should be based on sound scientific principles and published experimental results.

CONCLUSIONS

The relevant theory on the OOH advertising media is inadequate and does not address outdoor advertising audience measurement. This article therefore explored the trends and challenges as well as the practices in outdoor advertising audience measurement in South Africa.

The study has a number of implications for practitioners, as well as for academics. Unlike developed markets there still is no objective and standard audience measurement system implemented or accepted across the industry in South Africa despite several attempts to find a solution. Currently, different industry stakeholders have their own approaches and models to measurements.

This is problematic because without accurate and standardised audience data, the achievement of reach/frequency objectives and media weights cannot be verified or compared with above-the-line-media audience ratings. As a result the return on investment on outdoor advertising campaigns cannot be assessed and large advertisers are not likely to spend more on this medium if accountable and measurable indices are not refined. Ideally all the role-players in the industry should develop and adopt a standardized audience measurement system.

This research is not without limitations and offers some future research opportunities. The current study explored the audience measurement system of South Africa, which is clearly at an early stage of development. Hence, one could add value by examining the progress of audience measurement systems planned in other countries such as Chile, Poland and Turkey or compared developing and developed markets. Conducting case studies or field experiments to test the software-planning applications and GPS devices used for automatic tracking can also be worthwhile.

As an exploratory investigation, this article makes a contribution to appreciating the current state and challenges of audience measurement of outdoor advertising in a developing country. As gains in computing, in statistical methods and in technology continue to progress, it will be stimulating to follow the advances in systems

from a developed as well as developing market perspective. These and other related topics will be the focus of future research.

REFERENCES

- Bhargava, M., Donthu, N., and Caron, R. (1994). Improving the effectiveness of outdoor advertising: Lessons from a study of 282 campaigns. *Journal of Advertising Research*, 34(2), 46-56.
- Bloom, D. (2000). Measuring the audience to poster advertising. *International Journal of Market Research*, 42(4), 395-412.
- Burke, R. R. (2009). Behavioral effects of digital signage. *Journal of Advertising Research*, 49(2), 180-185.
- Carey, J. (2016). Audience measurement of digital TV. *International Journal of Digital Television*, 7(1), 119-132.
- Continental outdoor. (2017). Outdoor Cases. Retrieved from: <http://www.continentaloutdoor.com> (Accessed: 2017/01/20).
- De Bruijin, A., Ferreira-Borges, C., Engels, R., & Bhavsar, M. (2014). Monitoring outdoor alcohol advertising in developing countries: findings of a pilot study in five African countries. *African Journal of Drug and Alcohol Studies*, 13(1).
- Dennis, C., Newman, A., Michon, R., Brakus, J. J., & Wright, L. T. (2010). The mediating effects of perception and emotion: Digital signage in mall atmospherics. *Journal of Retailing and Consumer services*, 17(3), 205-215.
- Denzin, N. K., & Lincoln, Y. S. (2005). *Handbook of qualitative research*, 3.
- Donthu, N. & Bhargava, M., (1999). Sales response to outdoor advertising. *Journal of Advertising Research*, 39(4), 7-7.
- Donthu, N., Cherian, J., & Bhargava, M. (1993). Factors influencing recall of outdoor advertising. *Journal of Advertising Research*, 33(3), 64-73.
- Knoll, J. (2016). Advertising in social media: a review of empirical evidence. *International Journal of Advertising*, 35(2), 266-300.
- Lincoln, Y. S., & Guba, E. G. (1985). *Naturalistic inquiry* (Vol. 75). Sage.
- Lopez-Pumarejo, T.A., and Myles, B. (2009). The renaissance of outdoor advertising: from Harlem to Hong Kong. *American Journal of Business*, 24(2): 33-40.
- Nagel, P., & Louw, S. (2004). Mass media advertisements: responses to selected advertisements in semi-urban Limpopo. *Communicatio: South African Journal of Communication Theory and Research*, 30(2), 98-113.
- OMD. 2016. *SA & SADC Media Facts 2016*. Retrieved from (Accessed: 2017/05/28).
- Ornico. 2017. *The beauty of effective out of home advertising in Africa*. Retrieved from: website.ornico.co.za/wp-content/uploads/2014/11/The_Media_Report_2014_Independence_Issue.pdf (Accessed: 2017/05/28).
- Patterson, G. (2011). OOH, Where are we going? Retrieved from <http://themediainline.co.za/2011/07/ooh-where-are-we-going/> (Accessed: 2017/05/28).
- Patton, M. Q. (2005). *Qualitative research*. John Wiley & Sons, Ltd.

Price Waterhouse Coopers. (2016). *Global entertainment and media outlook 2015-2019 - PwC* Retrieved from: <http://www.pwc.com/gx/en/industries/entertainment-media/outlook/segment-insights/out-of-home.html> (Accessed: 2017/05/28).

Price Waterhouse Coopers (2013). *Global entertainment and media outlook 2013-2017 - PwC* Retrieved from: <https://www.pwc.no/no/innsikt/entertainment-media/global-media-outlook-2013.pdf> (Accessed: 2017/05/28).

Stengel. (n.d.). AZQuotes.com. Retrieved from AZQuotes.com Web site: http://www.azquotes.com/author/20181-Jim_Stengel (Accessed: 2017/01/20).

Primedia outdoor (2017). Primedia Outdoor steps up marketing services rollout into Africa PwC Retrieved from: <http://primediaoutdoor.co.za/2017/03/primedia-outdoor-steps-up-marketing-services-rollout-into-africa/> (Accessed: 2017/05/28).

Taylor, C. R. (2015). Creating win-win situations via advertising: new developments in digital out-of-home advertising. *International Journal of Advertising*, 34(2), 177-180.

Van Meurs, L., & Aristoff, M. (2009). Split-second recognition: What makes outdoor advertising work?. *Journal of Advertising Research*, 49(1), 82-92.

Vakratsas, D., & Ambler, T. (1999). How advertising works: what do we really know?. *The Journal of Marketing*, 26-43.

Wilson, R. T., Baack, D. W., & Till, B. D. (2015). Creativity, attention and the memory for brands: an outdoor advertising field study. *International Journal of Advertising*, 34(2), 232-261.

Wilson, R. T., & Casper, J. (2016). The Role of Location and Visual Saliency in Capturing Attention to Outdoor Advertising. *Journal of Advertising Research*, 56(3), 259-273.

This work is based on the research support in part by the National Research foundation of South Africa, Grant: 99338

ORGANISING THE GIANT THAT NEVER SLEEPS: DIGITAL OUT-OF-HOME (DOOH) ADVERTISING CLASSIFICATIONS

Thérèse Roux, Sfiso Mahlangu and Thembeke Lebese
Tshwane University of Technology

ABSTRACT

The tide of digital technology has moved the out-of-home advertising industry to a tipping point where static paper and paste advertisements on boards are being replaced with digital screens that are networked together, linked to the internet and capable of showing motion. The relevant theory on the digital out-of-home advertising media is inadequate and do not consider the potential opportunities across environments, formats or design innovations. No academic literature to classify or compare different digital out-of-home advertising media options could be found. For that reason, traditional out-of-home advertising is systematically compared with digital out-of-home advertising and digital out-of-home advertising taxonomies based on format, environment and design features are presented. The article serves to inform marketers of viable and cost-effective contemporary digital out-of-home advertising media opportunities. It also examines implications when using different formats, outside environments or design technologies. This article offers an orderly, integrated basis for future researchers to examine this emerging medium.

Keywords: Traditional, Digital, Out-of-home advertising, Marketing, South Africa.

INTRODUCTION

“Technology is like New York City, it never sleeps” (Ruiz, 2013). Nowadays, it is not unusual to see a Liquid Crystal Display (LCD) or plasma screen in public toilets, elevators, inside stores or buses. This new technology provides marketers with the opportunity to use highly efficient multimedia to inform promote and entertain specifically targeted consumers while they are outside their homes (Islam & Dahmalani, 2010). Digital out-of-home (DOOH) advertising offers advertisers the opportunity to engage with consumers who are spending increasingly more time away from traditional home-based media (The media online, 2015; PricewaterhouseCoopers, 2012). On average, the global consumer was exposed to DOOH advertising for 8 minutes per week in 2007, which then increased by 75% in 2013 to 14 minutes. It is estimated that in 2017 consumer exposure to DOOH advertising will grow at a compound annual growth rate (CAGR) of 8,6% to 20 minutes on average weekly exposure (PQ media, 2014). Traditional out-of-home (OOH) advertising with static non-digital content, such as posters and billboards, has become obsolete and is increasingly being replaced by new digital screens referred as DOOH advertising (Schaeffler, 2012). It is predicted that by 2018 traditional OOH revenues will begin to decline in South Africa – a trend that will have occurred on a global level by 2015 – but DOOH revenues will replace them. South African DOOH revenues will escalate to a compound annual growth rate of 20,3%, which will account for 31% of the market (PricewaterhouseCoopers, 2014).

The research problem and objectives will now be presented. Then traditional OOH advertising will be compared with DOOH advertising from a marketing perspective, followed by classifications of DOOH advertising. Finally, the managerial implications and suggestions for future research are presented.

PROBLEM STATEMENT AND OBJECTIVES

Surprising little research has been conducted on OOH advertising in recent years, with DOOH advertising remaining one of the most neglected topics in advertising research (Taylor, 2012). Despite the continuing growth, exposure and revenues of digital signage; there is still a lack of research on digital signage or DOOH advertising. Some research was conducted on the role of DOOH advertising in retail environment to provide customer experiences (Dennis, Brakus & Alamanos 2013; Dennis, Brakus, Gupta & Alamanos, 2014; Dennis, Michon, Brakus, Newman & Alamanos, 2012; Dennis, Newman, Michon, Brakus & Wright, 2011; Dennis, Newman, Michon, Brakus, & Wright, 2010). A few have explored the value of digital signage beyond commercial goals and retail environments to consider the impact on local communities and branding of the cities (Dennis, Michon & Newman, 2010). Thereby ignoring potential opportunities to reach audiences in transit environment or those waiting for a service or a product in specific venues (Dupin, 2011; Kelsen, 2012). Some have proposed a classification framework for traditional OOH advertising, but this does not apply to the growing range of DOOH advertising opportunities (Roux, van der Waldt & Ehlers, 2013). There still is not a complete understanding of the wide range of contemporary DOOH advertising media formats and designs across environments. The marketing implications of using contemporary DOOH advertising media rather than traditional OOH advertising are also not apparent. There is no orderly, integrated basis to describe and research this promising medium. Furthermore marketing practitioners might not be aware of all the available DOOH formats, the environments where they can advertise or the technical designs features to consider when using this medium. This article aims to overcome these identified gaps by answering the following questions:

- *How does traditional OOH advertising differ from DOOH advertising from a marketing perspective?*
- *What are the major types of DOOH advertising in terms of format, environment and design?*

COMPARING TRADITIONAL OOH WITH DIGITAL OOH ADVERTISING MEDIA

Out-of-home (OOH) media refers to advertising aimed at reaching people when they are outside of their homes, such as advertising on roadside billboards, inside and outside of busses and taxis and advertising on bus benches (Roux, van der Waldt & Ehlers, 2013). DOOH advertising utilizes networked digital signage displays that are strategically placed to reach mobile consumers with messages that are targeted at viewers in a particular environment. The message delivery is supported by dynamic and rich digital technology with real-time capabilities in order to target mobile consumers (The Interactive Advertising Bureau, 2016). The major differences between traditional OOH advertising media and DOOH media are outlined in table 1 below. These differences will be examined in the following sections.

Table 1: Differences between traditional OOH and Digital OOH advertising media

<i>Dimensions</i>	<i>Traditional OOH advertising media</i>	<i>Digital ooh advertising media</i>
<i>Targeting</i>	Mass communication	Targeted communication
<i>Content</i>	Static content	Digital content
<i>Marketing decision making</i>	Lack of customer insight for decision making	Customer insights and data to guide marketing strategies
<i>Type and purpose of communication</i>	Monologue one-way communication targeting consumers with predominantly branding messages	Two-way communication with customers allows communication and branding
<i>User interaction</i>	Not possible	Possible
<i>Measurement</i>	Basic measurement of traffic numbers	Advanced technology

Traditional OOH advertising such as billboards are placed next to major roads to obtain broad awareness (Chien, 2011). It results in media wastage when the message is ignored by individuals not part of the targeted market (Adams, 2016). An advertiser can customize DOOH content according to the demographics of people viewing the display at different times and locations so that the messages are targeted and appeal to a certain group of people (Van Bulck, 2011). For instance, digital signage displays that uses facial recognition technology and cameras to determine demographical information such as the age and gender of the person viewing the screen (Nead, 2011).

In the outdoor space, DOOH advertising has become a more effective form of communication compared to traditional OOH advertising (Low, 2015). This is due to the ability to display dynamic content and video material showing advertisements, community information, entertainment and news (Newman, Dennis, Wright & King, 2010). DOOH advertising consists of electronic displays, a media player and mechanisms that make it possible to upload and manage content appearing on the displays (Mattila, 2012). The advertisements that are displayed on the digital signage screen can be customized depending on the audience or time of the day or week. The content is already loaded on the media player and the advertiser can simply select the advertising content that they want to appear on the screen. For static OOH advertising such as billboards it can take up to months for the content to be changed because the process involve selecting the static location, designing the billboard, printing the design onto vinyl, and finally installing the billboard (Harkey, 2013). This can have a negative effect on businesses, because by the time the content is changed on the billboard, the message may no longer be relevant or can be outdated.

Correlation between sales and DOOH advertising can help the advertiser to determine the effectiveness of the advertisements (Burke, 2009). This information can guide decision-making and subsequent tailoring of campaigns. Since the content on digital screens can be changed quickly and easily, marketers can experiment on how and when to introduce new products, and incentivize purchases in order to drive more sales. Also if an advertised product becomes unavailable, the message on the DOOH advertising can be removed from the display instantly.

DOOH, especially digital signage, allows for a two-way dialogue that is manageable by the consumer and that allows for communication and branding (Avalos, 2010). Digital signage displays that utilize near field communication (NFC), a wireless connectivity technology that enables two – way communication between electronic devices, makes it possible for content to be shared with viewers when they touch an NFC tag on the digital signage display with their mobile phone. The tag content will then be sent to the viewer’s device. This enables marketers to communicate directly with consumers and also enabling consumers to respond if they are interested. It also allows shoppers to see products virtually displayed and compare products side-by-side or see a live feed of a business’s social media profile. Traditional OOH advertising does not have this type of electronic technology, making two-way communication impossible. Traditional OOH advertising follows a scripted flow within a one-to-many communication model, whereby a source sends out a single promotion that is seen by many recipients without the opportunity for immediate feedback that allows for two- way communication (Rowley, 2004).

The audience of OOH advertising has been challenging to measure, because it is difficult to scientifically establish whether mobile consumers are indeed exposed and noticed OOH advertising. Until recently, the size of audiences of traditional OOH advertising was basically measured by considering gross traffic numbers passing by a billboard, with many countries having next to no robust estimates of audiences (Bloom, 2000). The measurement of DOOH advertising is more advanced and relies on mobile location data to measure exposure. Mobile location data is used to check a device’s exact location and exposure by observing whether or not a consumer’s device was near a screen at the time of an ad run (The Interactive Advertising Bureau, 2016).

CLASSIFICATION OF DOOH ADVERTISING MEDIA

It important to differentiate between major types of DOOH advertising media so that marketers can use the best options to obtain their marketing communication objectives. The wide range of DOOH advertising can be classified based on their format, environment and design features (see figure 1). These criteria have been purposively selected, because they have proven to impact the effectiveness of OOH advertising and are known to the industry. OOH advertising format, such as the sizes and features are used by professional associations representing the OOH advertising industry to promote and measure this medium (e.g.OHMSA, 2016; OAAA, 2016). Some formats are more effective for vehicular traffic in urban areas and others for pedestrians, shoppers and waiting commuters (Roux, van der Waldt & Ehlers, 2013).

The location and position in an environment contribute significantly to both the likelihood and frequency of audiences’ exposure and the consequent recall of advertisements (Bhargava, Donthu & Caron, 1994; Bhargava & Donthu, 1999). *OOH advertising designs* that allow interaction or engagement with a target audience are suitable for

a captive audience (Wilson & Till, 2008), while high-impact visual cues and brief content are more effective in distracting roadside environment with fleeting exposure and low message processing (Van Meurs & Aristoff, 2009).

Figure 1: DOOH advertising classifications

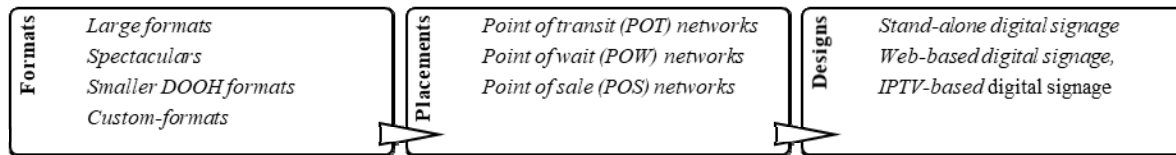

DOOH advertising media formats

The Interactive Advertising Bureau (2016) distinguishes between the following DOOH formats: large formats, spectaculars, venue based/public space and custom formats. These formats come in almost every shape and size and can be found in variety of environments such as public places, city areas, private venues, and highways (Kinetic, 2011). *Large formats* are larger than 15 meters in size and should be placed where motorists can see them clearly from a distance when driving on highways, industrial/high traffic commercial and major metropolitan areas (OAAA, 2016). Large formats of DOOH media should be designed to deliver high visual impact and exposure to a broad vehicular traffic without full motion to distract drivers' attention (Thompson, 2015). *Spectaculars* are placed in locations with heavy foot traffic in order to attain mass consumer exposure (OAAA, 2016). This type of DOOH advertising should aim to gain maximum attention through eye-catching special effects such as video screens that utilize full motion, three-dimensional sculpted features and various digital graphics. *Smaller DOOH formats* located in indoor venues and public spaces are mainly aimed at pedestrian traffic on street level or within at specific venues such as shopping malls, airports, pedestrian sidewalks and inside of taxis. DOOH formats in public spaces are placed in environments such as city streets where public access is not restricted and through which large volumes of people move such as bus shelters. DOOH formats in indoor venues are placed in areas where public access is limited such as airports (Kinetic, 2014). *Custom-formats* range from digital mobile billboards/busses, digital projections, to empty storefronts that are altered to create digital interactive experiences by using touchscreen and gesture technologies (ScreenMediadaily, 2016).

DOOH advertising media placements

The cost effectiveness of traditional OOH mass media advertising has declined in recent years, whereas targeted communications continues to grow (Vranca, 2009). With the inherent shortcomings of traditional media, brands and advertisers are starting to invest in newer marketing vehicles, such as digital signage, due to its ability to reach large audiences and play messages that are media rich, engaging and targeted at the point of wait, point of sale, and point of transit (PR Newswire, 2016). DOOH can thus be classified based on the locations or environments where they are applied, namely at the point of transit (POT), point of wait (POW), and point of sale (POS) (Kelsen, 2012).

Location is a critical consideration for any OOH advertising medium. An effective location ensures optimal exposure to the target audience and return on investment in terms of any favorable marketing results such as sales or awareness (Bhargava & Donthu, 1999; Wilson & Till, 2011). The impact of advertisements displayed can vary widely in different placement strategies. Harrison and Andrusiewicz (2004) identified physical location and venue type as the two most important aspects for cost reduction and increased effectiveness of digital signage for advertising purposes. Wilson and Till (2008) confirmed the importance of location as a critical element for the effectiveness of airport advertising. Thus, where the digital signage or traditional boards will be placed has a great impact on their effectiveness. Digital screens might be visually attractive, but that does not mean they can be installed anywhere and people will look at them. Therefore the location needs to be correct or the effect will be lost (Kinetic, 2011).

Point of transit (POT) networks includes digital signage inside bus stations and trains, taxis, airports and as well as digital billboards on the roadside such as highways or byways (Kelsen, 2012). The viewers of these networks are mobile because they are in transit when passing the sign, which causes them to have little dwell time to spend in

front of the screen and processing the messages, displayed (Shewan, 2014). Consequently messages need to be simple and bold in order to grab their attention (Moving Tactics, 2015).

Point of wait (POW) networks are designed for viewers who have longer dwell times such as those waiting for a service or a product in the food court area of a mall, corporate lobbies, healthcare and hospitality locations, as well as banks where consumers are in a queue waiting to be assisted by a bank teller (Dupin, 2011). These viewers at point of wait are generally more receptive and are longer exposed to messages displayed in this environment. This allows longer potential contact and several repetitions for marketers and retailers using these types of networks to deliver messages (Kelsen, 2012). Excessive queuing and waiting are regarded as some of the leading causes of dissatisfaction in retail stores, banks, hospitals, and government institutions. The networks in these venues aim to increase customer satisfaction and experience by changing customers' perceptions of the overall waiting time (Liang, 2013).

Point of sale (POS) networks are encountered by shoppers close to where a product or service is being sold (Dupin, 2011). In the retail environment point of sale networks are usually strategically placed to ensure that shoppers see them; at the shelves or at the end of the store aisle or public places of a shopping mall such as in the parking lot or entrance of malls (Islam & Dahmalani, 2010). The immediate call to action is the core strength of these networks because the screens are placed at the point of purchase to communicate advertising messages to shoppers when they are already in the mood to make purchasing decisions (Dennis, Newman, Michon, Brakus & Wright, 2010). Digital screens at the point of sale can increase sales and enhance the shopping experience of shoppers (Aradhana, 2016; Kelsen, 2012). Way finding systems in shopping malls that assist shoppers in finding specific stores located within the mall can make the shoppers' experience pleasurable, especially in big malls it can be a daunting task to find specific retail outlets (Bakija, 2016). Shoppers value benefits such as finding individual stores inside a mall with ease, entertainment, and enjoyment when doing their shopping (Awang, Aminudin, Hasim & Mustapha, 2013). Newman, Dennis, Wright and King (2010) found that digital signage creates a modern image for shopping malls, increases enjoyment, and provides shoppers with useful information. When a shopping environment is perceived pleasurable by shoppers, it is expected to put shoppers in a favorable mood, make them stay longer in the mall, and encourage approach behaviors such as spending (Dennis, Newman, Michon, Brakus & Wright, 2010). Digital signage also provides a sale opportunity in the shopping mall. The messages on the digital signage screens are usually directed to viewers who are in a receptive mind set to make purchase decisions (Kelsen, 2012). Therefore digital signage can help to make the task of shopping easier, which then enhances their shopper's experience.

DOOH advertising media designs

Understanding the type of technology incorporated in the design aid advertisers determining which customizing strategy can be followed. Digital signage can be classified based on their design namely stand – alone digital signage, web-based digital signage and IPTV – based digital signage (Khan, 2009).

Stand-alone digital signage consists of a display and a computer that is not connected to a network. The computer controls the content displayed on the digital signage. The content on the digital signage can be installed by either using a portable storage device or by using a universal serial bus (USB) memory stick (SKY – Technology, 2016).

With *web-based digital signage*, a local web browser is used to directly control the content on the digital signage. For a large number of displays that only display a limited amount of diverse streams of content this type of signage is required (Kim & Kim, 2015).

The *IPTV-based* digital signage is suited when content like image files; video, web contents, animations and graphics are distributed directly from a central media server to media players attached networked displays. A central network manager is responsible for organizing, managing and distributing the content to a media player connected to each of the displays (Yim, 2016).

CONCLUSIONS

The relevant theory on the DOOH advertising media is inadequate and do not consider the potential opportunities across environments, formats or design innovations. No academic literature to classify or compare different DOOH advertising media options could be found. For that reason, traditional OOH advertising was systematically compared with DOOH advertising and DOOH taxonomies based on format, environment and design features were presented. This article had to consult industry sources and publications from information technology due to the scarcity of academic literature on DOOH advertising. It can be argued that non-academic sources are not the same as scientific evidence. This further necessitates the need for scholarly research on DOOH advertising in the marketing discipline. This article has some implications for practitioners, as well as for academics. Realizing the implications of using DOOH advertising rather OOH advertising and might reduce potential risks and reluctance for marketers. It is envisaged that advertisers, marketers and media planners can use the classifications as guideline when evaluating and selecting different DOOH advertising options. Marketing scholars could investigate the marketing and social value of this growing range of DOOH advertising options platforms. It would also be valuable to conduct empirical research on the synergy and integration between DOOH advertising and location-based mobile and social media applications across environments.

REFERENCES

- Adamas, D. (2014). The evolution of digital signage marketing strategy. *Patroit* [Online], August 25, Available from: <http://patriot-tech.com/digital-signage-marketing/> [Accessed: 19/06/2016].
- Aradhana, G. (2016). Technological profile of retailers in India. *Indian Journal of Science and Technology*, 9(15): 1-16.
- Avalos, J. (2010). Digital place based media. *An independent supplement from mediaplanet in the wall street journal*, 3: 1-6.
- Awang, Z., Aminudin, N., Hashim, N. & Mustapha, N.A. (2013). Shopping mall attractiveness: Factors affecting consumer decision towards visitation. *Hospitality and Tourism: Synergizing Creativity and Innovation in Research*. United Kingdom: Taylor and Francis publishers.
- Bakija, M. (2016). Retailers look to digital signage to harness consumer. *AV Network* [Online], April 29. Available from: <http://www.avnetwork.com/systems-contractor-news/retailers-look-to-digital-signage-to-harness-consumer-data/123701> [Accessed: 21/06/2016].
- Bhargava, M. & Donthu, N. (1999). Sales response to outdoor advertising. *Journal of Advertising Research*, 39(4): 7-7.
- Bhargava, M., Donthu, N. & Caron, R. (1994). Improving the effectiveness of outdoor advertising: Lessons from a study of 282 campaigns. *Journal of Advertising Research*, 34(2): 46-56.
- Bloom, D. (2000). Measuring the audience to poster advertising. *International Journal of Market Research*, 42(4): 395-412.
- Burke, R.R. (2009). Behavioral effects of digital signage. *Journal of Advertising Research*, 49(2):180-185.
- Chien, C. 2011. Billboard Evolution. *The four peaks review*, 1(1): 86-97.
- Continental Outdoor. (2016). *Continental Outdoor* [Online], Available from: <http://www.continentaloutdoor.com> [Accessed: 25/02/2016].

- Dennis, C., Brakus, J.J., Gupta, S. & Alamanos, E. (2014). The effect of digital signage on shoppers' behavior: The role of the evoked experience. *Journal of Business Research*, 67(11): 2250-2257.
- Dennis, C., Newman, A., Michon, R. Brakus, J. & Wright, L. (2010). The mediating effects of perception and emotion: Digital signage in mall atmospherics. *Journal of retailing and consumer behaviour*, 17: 202-215.
- Dennis, C., Michon, R., Brakus, J., Newman, A. & Alamanos, E. (2012). New insights into the impact of digital signage as a retail atmospheric tool. *Journal of consumer behaviour*, 11(6): 454-466.
- Dennis, C., Michon, R. & Newman, A. (2010). The appeal of a town's separately branded environments to market segments and the segmented appeal of digital signage. *Place Branding and Public Diplomacy*, 6(2): 156-175.
- Dennis, C., Newman, A., Michon, R., Brakus, J.J. & Wright, L.T. (2011). *Modeling Shopper Responses to Retail Digital Signage*. Advanced Technologies Management for Retailing, Hershey, 41-69.
- Dennis, C., Brakus, J. & Alamanos, E. (2013). The wallpaper matters: Digital signage as customer experience provider at the Harrods (London, UK) department store. *Journal of marketing management*, 29(3): 338-355.
- Dennis, C., Newman, A., Michon, R. Brakus, J. & Wright, L. (2010). The mediating effects of perception and emotion: Digital signage in mall atmospherics. *Journal of retailing and consumer behaviour*, 17: 202-215.
- Dupin, F. (2011). Digital signage: the right information in all the right places. *International Telecommunication Union* [Online], November 29. Available from: <https://www.itu.int/oth/T2301000015/en> [Accessed: 11/01/2016].
- Harkey, S. (2013). How to evaluate and utilize digital out – of – home billboards. *B2B Marketing* [Online], October 15. Available from: <https://www.b2bmarketing.net/en-gb/resources/blog/how-evaluate-and-utilize-digital-out-home-billboards?currency=EUR> [Accessed:20/06/2016].
- Harrison, J.V. & Andrusiewicz, A. (2004). A virtual marketplace for advertising narrowcast over digital signage networks. *Electronic Commerce Research and Applications*, 3(2): 163-175.
- Islam, I. & Dahmalani, A. (2010). *Medium effectiveness: placement strategies for digital signage inside and outside store locations*. Master's Thesis, Umea School of Business.
- Kelsen, K. (2012). *Unleashing the power of digital signage: content strategies for the 5th screen*. Amsterdam: Elsevier
- Khan, A.R. (2009). Digital signage system. *Master's Thesis, School of Information and Communication Technology Royal Institute of Technology*, Stockholm Sweden.
- Kim, W.Y. & Kim, S. (2015). The Digital Signage System Supporting Multi-Resources Schedule on an Elevator. *International Journal of Smart Home*, 9(8): 219-228.
- Kinetic. (2011). Global digital out of home handbook. *Kinetic* [Online], January 1. Available from: http://www.google.co.za/url?q=http://www.neoadvertising.com/ch/wp-content/uploads/2011/12/Global_Digital_Handbook_Philosophy.pdf&sa=U&ved=0ahUKEWj5i5So4_MAhWDCBoKHZnDB9gQFggRMAI&usg=AFQjCN_GHubNivMH6-gMs6jbbYi42VckJCg [Accessed: 15/05/2016].
- Liang, C. (2013). Customers waiting in front of a retail store. *Hawaii International Conference on System Sciences*, 46: 1310-1316.

- Low, S.Y. (2015). Clear channel leads digital out-of-home (DOOH) advertising in Asia – with a seven – fold expansion of its digital 6-sheet inventory. *Clear channel* [Online], November 11. Available from: www.clearchannel.com.sg/2014/clear-channel_duplicate/2015/11/11/clear-channel-leads-digital-out-of-home (dooh)-advertising-in-asia-with-a-seven-fold-expansion-of-its-digital-6-sheet-inventory [Accessed: 10/05/2016].
- Mattila, P. (2012). Digital decisions: How digital signage networks generate profit. Bachelor's Thesis, Turku University of Applied Sciences.
- Moving Tactics. (2015). Why digital signage? – creating customised digital signage content (Part 2). Available from: <https://movingtactics.co.za/why-digital-signage-creating-customised-digital-signage-content-part-2/> [Accessed: 20/06/2016].
- Nead, N. (2011). Facial recognition in Digital Advertising. *MediaSignage* [Online], July 6. Available from: blog.digitalsignage.com/facial-recognition/ [Accessed: 21/06/2016].
- Newman, A., Dennis, C.E., Wright, L. & King, T. (2010). Shoppers' experience of digital signage – a cross-national qualitative study. *International Journal of Digital Content Technology and its Applications*, 4(7): 50-57.
- OHMSA. (2016). OOH Classification matrix. Out of Home Media association of South Africa Available from: <http://www.ohmsa.co.za/> [Accessed: 16/12/2016].
- OAAA. (2016). Out of home advertising. *Outdoor Advertising Association of America*. Available from: <https://oaaa.org/> [Accessed: 16/12/2016].
- PR Newswire. (2016). Brazilian digital signage services market: advertising investment in Digital Out-of-Home media drives digital signage adoption in the country. *Pr Newswire* [Online], March 30. Available from: www.prnewswire.com/news-releases/brazilian-digital-signage-services-market-300243534.html [Accessed: 16/05/2016].
- PriceWaterhouseCoopers. (2014). Entertainment and media outlook 2014 – 2018 South Africa – Nigeria – Kenya. *PricewaterhouseCoopers* [Online], September 1. Available from: <https://www.pwc.co.za/en/assets/pdf/entertainment-and-media-outlook-2014-2018> [Accessed: 19/06/2016].
- Roux, T., van der Waldt, D.L.R. & Ehlers, L. (2013). A classification framework for out-of-home advertising media in South Africa. *Communicatio*, 39(3): 383-401.
- Rowley, J. (2004). Just another channel? Marketing communications in e-business. *Marketing Intelligence & Planning*, 22(1): 24-41.
- Ruiz, A.L. (2013). Technology is like New York....it never sleeps. Prezi [Online], November 13. Available from: <https://prezi.com/fevdumwle-gv/technology-is-like-new-york-it-never-sleeps/> [Accessed: 27/02/2016].
- Schaeffler, J. (2012). *Digital Signage: Software, Networks, Advertising, and Displays: A Primer for Understanding the Business*. Oxford: Elsevier.
- Screen Media Daily. (2016). Creative digital out-of-home advertising combines lifestyle interest with location targeting. *ScreenMediadaily* [Online], June 1. Available from: <http://screenmediadaily.com/creative-digital-out-of-home-advertising-campaigns/> Accessed: 15/05/2016].
- Shewan, D. (2014). Dwell time: the most important metric you're not measuring. *Wordstream online advertising made easy* [Online], June 10. Available from: www.wordstream.com/blog/ws/2014/06/10/dwell-time [Accessed: 19/04/2016].

Sky – Technology. (2016). Digital signage part 1: what is digital signage?. *SKY – echnology* [Online], April 19. Available from: <http://www.sky-technology.eu/blog/article/item/digital-signage-part-1-what-is-digital-signage.html> [Accessed: 16/12/2016].

Taylor, C.R. (2012). Editorial: Back to the future: some topics we should not forget about in advertising research. *International Journal of Advertising*, 31(4): 699-702.

The Interactive Advertising Bureau. (2016). Digital Out-of-Home Buyer's Guide. Available from:

<http://www.iab.com/wp-content/uploads/2016/02/IAB-DOOH-Buyers-Guide-Draft-FINAL.pdf> [Accessed: 16/12/2016].

The Media Online. (2015). Out of home, switched on and full of opportunities. *The Media Online* [Online], June 20. Available from: <http://themediainline.co.za/2015/06/ooh-switching-on-to-specialist-agencies/> [Accessed: 07/02/2016].

Thompson, E. (2015). The impact wit big outdoor. *Disqus* [Online], May 13. Available from: <http://www.forwardandthinking.com/oohadvertising/> [Accessed: 21/06/2016].

Van Bulck, H.E. 2011. The Effectiveness of Outdoor LED Advertising Signs.

Van Meurs, L. & Aristoff, M. (2009). Split-second recognition: What makes outdoor advertising work?. *Journal of Advertising Research*, 49(1): 82-92.

Wilson, R.T. & Till, B.D. (2011). Effects of outdoor advertising: Does location matter?. *Psychology & Marketing*, 28(9): 909-933.

Wilson, R.T. & Till, B.D. (2008). Airport advertising effectiveness: An exploratory field study. *Journal of Advertising*, 37(1): 59-72.

Yim, J. (2016). Design of an IPTV-Based digital signage system. *International journal of multimedia and ubiquitous engineering*, 11(4): 125-136.

ACKNOWLEDGEMENT

This work is based on the research support in part by the National Research foundation of South Africa, Grant: 99338

INCIDENCE OF CULTURAL ACTIVITIES IN TOURISM FOR DESIGNING TOURIST PRODUCTS IN GUAYAQUIL

Jael Gudiño Ruiz, Alba Caicedo Barreth and Marlon Salazar
University of Guayaquil, Ecuador

ABSTRACT

Guayaquil is the economical capital of Ecuador, and also contains history, culture and traditions that attract the attention of tourists and visitors who arrive to this destination offering countless tourist attractions. This research sought to define the relationship between culture and tourism in the approach of visitors' preference, so that, basis for designing tourist products in Guayaquil be laid. A mixed approach was applied, linked to theories and definitions that supports the validity of collected information. Analysis contains descriptive and inferential results that provide relation between cultural apprehension and tourism. Practical implications contain two models of variables immersed in value folk as important element for tourist places and motivation for attending a folk event, and also two kind of possible cultural tourists are revealed.

Keywords: tourism attraction, cultural places, folk, tourism, culture.

INTRODUCTION

Through the years Guayaquil has been developing in tourism, trying to become an important tourism destination, catching national and foreign tourists. That progress has been based in fairs, congress, and professional events, which are part of the monthly calendar of the city. That is why Guayaquil is well known as a business destination but not for historical or cultural aspects that are also part of this Ecuadorian metropolitan city.

Other cities of Ecuador, however, have gotten relevant recognition as Patrimonial centers, cultural spots and traditional towns. For instance, Quito and Cuenca are exceptional model of those identification, thus a first question emerges in this research: How are the characteristics that could make tourist prefer to choose cultural centers in their visits? Under this premise and that as background the Andean region in Ecuador has developed folk identity, is pretending to identify the incidence of cultural activities in tourism for designing new tourist products in Guayaquil.

THEORETICAL BASIS

The connection between the culture and tourism is a significant combination for the development of any city. Nowadays the cultural activities are losing its value and the meaning that provide the necessary contribution of the advancement of a country, city or region. The daily grind, customs and traditions represent an important value, by building within social responsibility, opportunities of manage progress and principally to make the customs be worth to all (López, 2003, p. 9). In consequence as Fondevilla, Puiggrós, Muñoz and Berbel (2017) refer, culture has become a relevant axis for tourism industry (p. 112), and in some countries as Spain is the second most important sector (Carrasco-Santos and Padilla-Meléndez, 2016, p. 145).

Some authors pretend to get a difference between tourist attractions and tourist resources, and others note they are the same. Consequently cultural activities are part of the tourism system. It can be classified into some components that fulfill essential functions in tourism. Boullón (2006) refers about tourism attractions as the main product, meaning that they could contribute to the development of the tourism industry. Tourist attractions according to some authors agree that are classified by: natural and cultural and by other categories and sub-categories where folklore remarks. (Navarro, 2015, p. 345) (OEA-CICATUR, 2011, p. 3) (Boullón, 2006, p. 45) (MINTUR, 2004) (Ramírez Blanco, 1998, p. 62) (Acerenza, 1994, p. 211) (Gurría di Bella, 1994, p. 48) (Sancho, 1998, p. 132).

In consequence, culture could be part of a touristic product, reminding their characteristics of intangibility, expiration dates, inseparability, heterogeneity and focus on marketing strategies including digital and measurable (Fondevila Gascón, 2014, 2017, p.112); as Lopez (2003) mentions that tourism and culture are relevant linked for the development of a community “because of tourist attraction to offer”.

Cultural tourist attractions

Indeed, to have a better understanding about folklore is necessary to emphasize that tourist attractions are the main part of the resources offered. In fact, the income in a city or town is based on the development of the tourism. The tourist attractions are supplemented by three parts: human contribution, the surroundings in which is developing, and the tourism as an economic activity (Boullón, 2006) (Ricaurte, 2009).

Therefore, tourist attractions are divided by: natural, cultural manifestations, folklore, contemporary building and events (OEA-CICATUR, 2011, p. 2). In that approach the cultural attractions are represented by any type of historical and artistic expression (Boullón, 2006), in which the folklore is highlight, established in many ways such as the explanation in Figure 1:

Figure 1: Folklore as cultural attraction

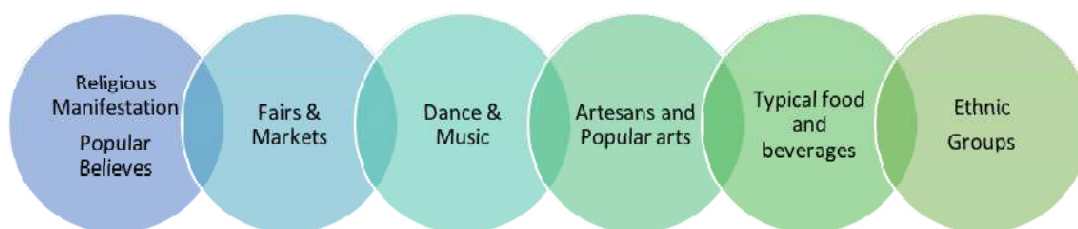

Source: Taken from Boullón (2006)

Cultural attractions involved some variety of activities which are useful for society and tourism, connecting in a permanently way the history and the evolution of that place. The identity of the community is built by creating conservation and high importance of the product, offering a product of quality. (Partners for Livable Communities, 2014, p.10) (Dormaels, 2012, p. 10) (Acerenza 1994)

Obviously every historical place or attribute conserved in a town, city or village and also culture, traditional ways to do things could be cultural attractions if those help to develop as an important tourist product, streamlining the social and economic system (Curiel, 2011). In terms of cultural tourism, some studies have focus on museums and geographical aspects (De Esteban Curiel, Sánchez García and Antonovica, 2013) (Fondevilla et al, 2017, p.112), therefore the following research questions were established:

Q1: What areas in Guayaquil are visited by tourists who enjoy cultural attractions?

Q2: What kind of cultural attractions are relevant for tourist?

Folklore Classification

Garcia (1994) refers that folklore expressions appeared in the early XIX – XX in the European continent, where the culture and traditions remained very important to all social classes, because history and culture was immersing in all major events in that continent.

Meanwhile some others say that folklore appeared in part of the European continent, but also in part of the African continent, specifically in the mountains and caverns in which man did its first attempt to make figures. The arguments are based on the figures made by man or the sorceress representations, hunters, or tribes dancing making reference of their culture. (Iturria, 2008, p. 9) (Escobar, 2002)

Folklore is a social activity developed constantly in certain dates or schedules programs with important characteristics such as festivities in a particular place, which involves dances (rituals), represents and make remember the history of ancestors by the traditional rhythm and music. (Iturria, 2008, p. 11) (Caicedo, 1999). Tabora (2002) refers folklore as an activity where remarks dancing and music of a place or a define a region, showing society where they came from, their traditions, customs and reviving old times memories through artistic shows, transmitted by word of mouth and learned by imitation. (Harun and Jamaludin, 2013, p119)

In Latin America the meaning of folklore, according Carvalho (1994), come from the English word “Folk” that means town and “Lore” that means knowing, in summary both words together say “*the knowledge of a town*”. Some authors like Emery (2017) refers there are 11 types of folk, nevertheless, Carvalho in 1989 says that (...) there is another classification focusing not only in the music and custom dance, categorization spread by the whole South American territory. (Figure 2)

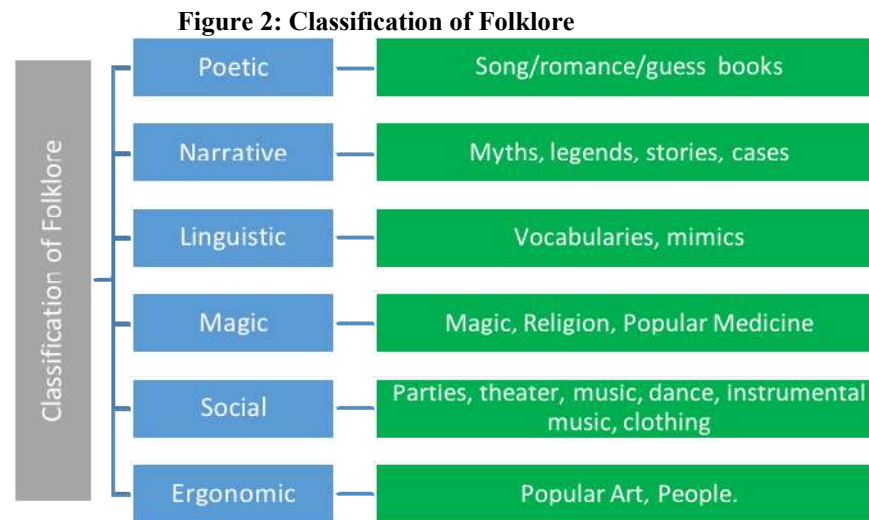

Source: Taken from Paulo Carvalho Neto 1989

Folkloric Activities

Folkloric activities are representation of cultural activities of any determine region in which culture is demonstrate to other to forge identity, trying to be transmitted to next generations (Carvalho, 1989). Those type of activities as mentioned Caicedo (2015) has an extensive variety which could be classified by areas:

- The beliefs include all type of ideas that human has through his life period, either by magic, superstitions, witchery or other mythological forms.
- The customs globally are the festivities, games, and dance, and also involving gastronomy and typical cloths.
- The stories comprise traditional music, stories based on historical events and relevant characters.

- The popular art refers to the mixture of music and dance, making the artistic manifestations, that is why theaters are also relevant to be included.

In that context, folklore is a cultural activity, which has been part of the tourism within a nation. It is important to say that within that area the intangible heritage is protected, thus dance, music, verses and poems reminding ancient times are developed. So, a Folk Center is a place of interpretation, in which shows the public the dance and native music, by making shows in event rooms, theater or urban stage on the streets (Apicella, 2004). Consequently, three research questions arose over those basis:

Q3: How much is folk a relevant component for tourism in Guayaquil?

Q4: What are the motivations for attending a folk event?

Q5: How many factors could be defined as motivation to attend culture in tourism?

METHODOLOGY

The scope of this research was to analyze the incidence of cultural activities in tourism in Guayaquil for designing tourist products. The research design consisted in a mixed approach where was collected qualitative and quantitative data (Hernández-Sampieri, Fernández & Baptista, 2010), requiring information about the immersed variables: cultural activities and tourist product towards two well identified groups: tourist and cultural operators. Consequently, as type of research was used bibliographic and field work.

Regarding sample data, as important component to proceed on research, population was provided by statistics of Public Enterprise of Tourism in Guayaquil. From a universe population of 2'286.518 tourists by year, the formula for finite population was applied, with reliability of 95% and error of 5% of, therefore 384 surveys were held to national and foreign tourists in Guayaquil on weekends in the period of June to September, 2016; excluding people from Guayaquil, minors and tourist operators.

Analysis of the validity and reliability of the scales was done by SPSS program. The final measurement model for reliability in the Cronbach's Alpha was of 0,944 in 10 items. Factor analysis by KMO and Bartlett's Test was used to test the validity of the scales used, obtaining 0,879 with a significance of 0,000.

Diverse theoretical methods were introduced in the study. They included historic-logic, analytic-synthetic, induction-deduction. Historic-logic was applied in the way to identify and prove through assorted files the evolution of folk indicators in the tourism field. Analytic – synthetic tried to review every tourist cultural attraction that could be considered for visitants, thus a way of future solutions on cultural activities on tourism information was synthetized. Finally, induction - deduction was functional from the surveys, were specific data about folk activities in Guayaquil could be useful in tourism.

Therefore, the study required the use of techniques and research tools to collect data. Techniques applied were observation, surveys and interviews. Through observation was collected qualitative data about current cultural activities and cultural operators in Guayaquil. To elaborate files of observations, a validation through number was used to rank results as excellent, good, regular and bad (Hernández-Sampieri et al, 2010).

About surveys, as sample was considered tourist who visited Guayaquil, as consequence queries were concerned to value folk as one important element in the tourist places; preferences of cultural activities; motivation for attending a folk event; times of attending a cultural event in a year; folk dances of preference to observe at a show; preferences among shows, music, costumes and souvenirs; favorite ways to receive information about culture; ability to pay for a cultural event; apprehension of culture for visitants.

Interviews were also done to three experts through open questionnaires about develop of folk, relationship of tourist and folk, negative factors that impede the development of folk, affluence of visitants to cultural activities, support by government entities and acceptance of a folk center.

ANALYSIS OF THE RESULTS

Descriptive statistics

Folk activities are those manifestations exposed in a rhythmic scenic way through popular knowledge based in customs and traditions of a town or region of origin, offering the public a sociocultural aspect in which to learn to value the culture of the ancestors allowing to welcome it as a legacy important. (Castro, 2010) (Iturralde, 2008)

As first stage, folk operators as group of dances was considered to count the existence of suppliers. Those cultural groups labor in incentivate and valorate the ecuadorian cultural identity, there were counted 20 cultural operators, some of them has until 50 years.

Subsequently, research analysed tourist places willing to develop cultural activities in Guayaquil, trying to answer **Q1**. There were provided 8 areas where actually some shows, events and expositions are organized. In the following paragraphs will be display their current function, after the observation technique:

Malecón Simón Bolívar and Malecón del Salado are preferred areas by hundreds of tourists, they are urban trails where families could converge with natural environment, areas of music, art, exhibitions and others, however not in every case are exposed national genders and expressions.

Guayaquil Historical Park has both types of attractions, because of their natural life, and traditional, architectonic and urban part of the ancient Guayaquil. Some shows take place in the Main Traditional House, where visitants and tourist converge. There are also Montubio theater played.

Museums, as relevant places where culture is shown, develop in their agendas some specific educational programs. The most recognized museums with current cultural programs and most-visited are MAAC and Presley Norton. MAAC is an organization with two areas to play art, music and dances expressions, every week at least two programs are played there. Presley Norton have cultural evening almost every two weeks and is also well known by regular courses in the same category.

Theaters, regular places where music, dance and theater converge. In Guayaquil, Aula Magna from ESPOL every Monday provide a cultural program to community for free. Sanchez Aguilar theater played every week musicals for payment. The Culture House has also some agendas monthly for payment and for free.

Finally, surveys were applied, in reference to answer **Q2**, and those revealed the following results:

Regarding to value folk as one important element in the tourist places, 82% considered it as a fundamental component, and other 17% is also agree that this activity has to be part of tourist areas. About preference of cultural activities, 16% prefers theater, 15% painting, 59% cultural dances and 10% musical concerts. Answers in motivation for attending a folk event, referred that people in a 69% is influenced by general culture, 17% by own preferences, 3% by recreation and 11% others reasons.

Concerning times of attending a cultural event in a year, 72% of people mentioned once in a year, 16% every weekend, 11% one to three times in a month. Regarding the kind of preferred folk dances to be observed at a show, 52% indicated pasillos, 22% pasacalles and 26% montubio's dances. In the approach of preferences among shows, music, costumes and souvenirs that converge in a potential folk center: 76% of tourists answered folk shows, 10% national music, 8% souvenirs, and minor percentages costumes and general exhibitions.

About favorite ways to receive information about culture, the most reflected answered was social media with 46%, web pages 23%, television 17% and 15% cultural agendas. Concerning ability to pay for a cultural event: 85% of tourist mentioned ability to pay until \$15, other 13% of visitants stated about \$25, and others minority more than before mentioned amount. Staring apprehension of culture for visitants, 73% of people declared that for them music and dance means culture, 13% referred are costumes and 10% indicated that instruments are culture for them.

Inferential Statistics

In order to answer Q3, Q4 and Q5, correlation was used and confirmed by regression analysis:

Two models were applied with different variables with value folk as important element in tourist places as dependent variable. The first model tried to search for correlation among ways to receive information, folk center and preference of cultural activities, which showed difference in the significance level of two variables. The second model was done with most correlated variables: Preference of cultural activities, ways to receive information, apprehension of culture for visitants and folk center as interest; with a confidence level of 95%, and significance of 0,000 among all independent variables.

Table 1: Model based on value folk as important element

		Coefficients ^a					95.0% Confidence Interval for B	
Model		Unstandardized Coefficients		Standardized Coefficients	t	Sig.	Lower Bound	Upper Bound
		B	Std. Error	Beta				
1	(Constant)	2,634	,102		25,884	,000	2,434	2,834
	Ways to receive information	,175	,031	,355	5,624	,000	,114	,237
	Folk center	,364	,032	,538	11,209	,000	,300	,427
	Preference of cultural activities	,119	,032	,227	3,722	,000	,056	,182
	Apprehension of culture for visitants	-,162	,023	-,341	-7,118	,000	-,207	-,117

a. Dependent Variable: Value folk as important element

Table 2: Model based on motivation for attending a folk event

		Coefficients ^a					95.0% Confidence Interval for B	
Model		Unstandardized Coefficients		Standardized Coefficients	t	Sig.	Lower Bound	Upper Bound
		B	Std. Error	Beta				
1	(Constant)	1,052	,045		23,459	,000	,964	1,140
	Times of attending	,263	,041	,284	6,386	,000	,182	,343
	Preference among shows, music, c	,245	,031	,254	7,872	,000	,183	,306
	Ways to receive information	,091	,019	,120	4,776	,000	,054	,129
	Apprehension of culture for visitants	,436	,039	,598	11,299	,000	,360	,512
	Ability to pay for cultural event	-,415	,049	-,278	-8,477	,000	-,512	-,319

a. Dependent Variable: Motivation for attending a folk event

Concerning motivation for attending a folk event as a dependent variable, previously was prepared models considering multiple variables, where folk of dance had a weak relation, so the final model was evaluated with the following variables: times of attending an event in a year; preference among shows, music, concerts and others; ways to receive information; apprehension of culture for visitants and ability to pay for cultural events; with a confidence level of 95%, and significance of 0,000 among all independent variables. (See on table 2)

Table 3: KMO and Bartlett's Test

KMO and Bartlett's Test		
Kaiser-Meyer-Olkin Measure of Sampling Adequacy.		,879
Bartlett's Test of Sphericity	Approx. Chi-Square	5710,973
	df	45
	Sig.	,000

As Table 3 reveals, by factor analysis was examined the KMO and Barlett's Test with a value of 0,879 and significance of 0,000, so the total variance explained revealed that there are two important components that display as loadings cumulative a value of 87,38%. Through the rotated component matrix were identified the main variables that influence each factor:

FACTOR 1: Motivation for attending a folk event, Times of attending an event in a year, folk dances of preference, event of preference, ways to receive information, ability to pay, apprehension of culture.

FACTOR 2: Value folk as important element in tourist places, preference of cultural activities and interest in a folk center

CONCLUSION

The diagnosis of the current tourism in Guayaquil, revealed the shortage of cultural activities supporting tourism. That reaction allows focus on new trends to be employed in this city, where culture and folk are part of. Dances and music are relevant tourism attractions and are preferred by tourist, thus those promote the tourism of cities and countries framed in the social, legal and economic, for the welfare of the folk activities. Over those basis, developing folk activities as a new tourism product in Guayaquil must be part of tourism policies stated by government.

MANAGERIAL IMPLICATIONS

The practical implication of the factor analysis is to identify two groups of tourists. The first one is a person that want to know the traditions and culture as general knowledge of their visit. The second one is someone who really prefer cultural activities, and enjoy this kind of entertainment in their tourism. In consequence, managerial implications refer to design cultural tourist product considering those motivational aspects supported in this research.

REFERENCES

- Acerenza, M. A. (1994). *Administración del Turismo- Conceptualización y Organización* . México: Trillas .
- Apicella, M. (2014). *Encuentros folklóricos itinerantes*. La nación. Barrera, R. (1998). *El Folclor en la educación*. Buenos Aires Argentina: COLIHUE.
- Boullón, R. (2006). *Planificación de los Espacios Turísticos*. México: Trillas.
- Caicedo, F (1999). *La Costa y su Folclor* . Guayaquil: Facultad de Comunicación Social.
- Caicedo, F (October, 2015). *Backgrounds of folk dances and groups of dances* (M. Salazar, Interviewer)
- Carrasco-Santos & Padilla-Meléndez (2016). The role of satisfaction in cultural activities' word-of-mouth. A case study in the Picasso Museum of Málaga (Spain). *Tourism & Management Studies*, 12(1), 145-152
- Carvalho, P. (1989). *Diccionario de Teoría Folclórica: Folclor General*. Ecuador: ABYA-YALA.
- Carvalho, P. (1994). *Antología del Folklore Ecuatoriano*. Azuay: Casa de la Cultura Ecuatoriana.
- Castro, J. R. (2010). *Ensayo Critico del Turismo como ciencia* . In Castillo & Panoso, *Epistemología del Turismo*. México: Trillas.
- Curiel, J. d. (2011). *Turismo Cultural y Gestión de Museos*. Madrid: Dykinson. S.I.

- Dormaels, Mathieu. (2012). Identidad, comunidades y patrimonio local: una nueva legitimidad social. *Alteridades*, 22(43), 9-19. Retrieved from: http://www.scielo.org.mx/scielo.php?script=sci_arttext&pid=S0188-70172012000100002&lng=es&tlng=es.
- Escobar, C. P. (2002). *Al Ritmo de nuestro Folclor*. Bogotá- Colombia: San Pablo .
- Emery, David (2017) Types of folklore. Thought Co. Retrieved from: <https://www.thoughtco.com/types-of-folklore-3299721>
- Fondevila Gascón, J. F. (2014). El uso de hipertexto, multimedia e interactividad en periodismo digital: propuesta metodológica de ranking de calidad. *ZER, Revista de Estudios de Comunicación (Journal of Communication Studies)*, 19(36), 55-76.
- Fondevilla, Puiggrós, Muñoz & Berbel (2017). Cultural tourism in Barcelona: an empirical analysis of information from different types of establishments. *International Journal of Scientific Management and Tourism*, 3(1), 111-121.
- García, C. O. (1994). Antropología y Folklore. *Revista de Dialectología y tradiciones populares*, 50.
- Gurría Di Bella, m. (1994): *Introducción al Turismo*. México, Trillas
- Harun, H & Jamaludin, Z (2013). Folktale conceptual model based on folktale classification system of type, motif, and function. *Proceedings of the 4th International Conference on Computing and Informatics, ICOCI 2013* 28-30 August, 2013 Sarawak, Malaysia.
- Hernández-Sampieri, Fernández, C & Baptista, L (2010). *Metodología de la Investigación*. México: Mcgraw-Hill / interamericana editores, s.a. de c.v.
- Iturralde, W. O. (2008). *Folklore Montubio y Sociedad*. Manabí: Mar Abierto.
- Iturria, R (2008) *Tratado de folklore. Estudios históricos*. Retrieved from: <http://www.estudioshistoricos.org/libros/raul-iturria.pdf>
- Lopez, G. (2003). *Patrimonio Cultural y Turismo*. México D.F: Archive from Centro de Documentación Daniel Rubin de la Borbolla. Retrieved from: http://www.cultura.gob.mx/turismocultural/publi/Cuadernos_19_num/cuaderno5.pdf
- MINTUR (2004). *Inventario de atractivos turísticos*. Ministerio de Turismo del Ecuador
- Navarro, D (2015) *Recursos turísticos y atractivos turísticos: Conceptualización, clasificación y valoración*. *Cuadernos de Turismo*, n° 35, (2015); pp. 335-357
- OEA-CICATUR (2011). *Guía metodológica Cicatur Modificada*. Retrieved from: https://turgeoyanedel.files.wordpress.com/.../guia_metodologia_cicatur_modificada_rfs2011.pdf
- Partners for Livable Communities (2014) *Culture Heritage Tourism*. Retrieved from: <http://www.livable.org/storage/documents/reports/CBC/culturalheritagetourism.pdf>
- Ricaurte, C. (2009). *Manual para el Diagnóstico Turístico Local*. Turismo y sus elementos. Guayaquil, Guayas, Ecuador: Escuela Superior Politecnica del Litoral .
- Sancho, a. (Dir.) (1998): *Introducción al turismo*. Madrid, Organización Mundial del Turismo
- Tabora, J. M. (2002). *Folklore y Turismo*. Tegucigalpa - Honduras: Guaymuras.

USAGE PATTERNS OF ACTIVITY-BASED COSTING AND THE IMPEDING BARRIERS TO ADOPTION BY MANUFACTURING SMEs IN GAUTENG, SOUTH AFRICA

Rosebud Rundora
Vaal University of Technology, South Africa

Job Dubihlela
Cape Peninsula University of Technology, South Africa

ABSTRACT

Activity-based costing (ABC) is known to provide more accurate and useful information to help organizations appropriate their valuable resources for producing quality goods and services in a competitive environment. For capital intensive environments such as in manufacturing, activity based costing has been found to be more appropriate. Realizing the importance of ABC, notable research has focused on its design and implementation, ignoring sector specific implications and implementation barriers. This study is an attempt to identify the barriers impeding the adoption of ABC and the usage patterns by small and medium manufacturing firms (manufacturing SMEs). Quantitative research approach was used and the selected respondents were requested to complete a structured questionnaire on the barriers impeding their adoption of the ABC system as well as the reasons why some firms have not yet adopted the system. The users' responses and the non-users' responses were analyzed. The findings in the study revealed 4 key barriers impeding the adoption of ABC by the non-users. The barriers include the high cost of implementing the system, resistance to change, high priority given to other projects and lack of knowledge. This study provides some sentience into the apparent paradox, in the part that despite the well-known benefits of ABC, relatively few manufacturing SMEs employ it and that a material number of those that embrace ABC do not actually implement it. The findings point to the fact that impending barriers to activity-based costing are influenced by organizational innovation processes. It also shows that organizations that adopt and implement ABC are mostly large enterprises. The results suggest that the issues faced by the implementers of ABC in South Africa are similar to those faced in many other countries worldwide.

Keywords: Activity-based costing; small firms; usage patterns; implementation barriers.

INTRODUCTION

Global competition has led different types of businesses towards a renewed commitment to high levels of competitiveness within their business operations. Small and medium manufacturing firms are facing ever-increasing competition in today's global market environment and according to Roztocki, Porter, Thomas and Needy (2004), firms should react quickly and be able to manufacture high quality low cost products in order to successfully compete in this dynamic business environment. Small and medium manufacturing firms in any economy enable income stability, enhance economic growth, upgrade human capital and contribute to poverty alleviation (Elliot & Boshoff, 2007). Their failure to maintain strict control over costs and inability to track cost centers can ultimately result in massive financial losses and potential organisational failure (Merchant & Van der Stede, 2007).

The success of most manufacturing SMEs' depends on the product value delivered to customers. This emanates from capacity to remain relevant and competitive and be able to make proper decisions. It is therefore

imperative for these organisations to have accurate and up-to-date costing information for product quality and managerial decision making purposes. One innovative costing method that was designed to help companies boost their profitability and decision-making process is the Activity-based costing system (ABC). ABC has become the focus of attention of management production theorists, researchers and practitioners, eclipsing traditional costing methods in recent years (Mortaji, Bagherpour & Mazdeh, 2013). This method is able to provide more accurate cost information for companies and also assist managers to make decisions at a group level. Furthermore, Haroun (2015) indicated that ABC provides better profitability measures and improved product costing that leads to enhanced estimation of job costs for pricing decisions. It has been asserted by Sandino (2007) that ABC is a very useful tool for small firms, providing benefits for their cost-efficiency and decision-making in pursuing competitive advantages as well as improved performance.

Despite the benefits derived from implementing the ABC system, there are still several companies, particularly manufacturing SMEs that are reluctant to adopting the system. Laggards point the following reasons for non-adoption; lack of finance, lack of education and training and lack of knowledge and although numerous ABC implementations have been reported in the large manufacturing firms, less frequent is the implementation of ABC in small manufacturing firms (Roztocki et al. 2004).

Traditional cost accounting methods utilizes bases such direct labor, man hours and machine hours to allocate costs to products the expenses of indirect and support activities, such as engineering changes, setups, and machine parts, maintenance etc. Contrarily, activity-based costing isolates the expenses of indirect and support resources by operational activities, assigning those expenses based on the drivers of the activities. Against this background, this study sought to examine ABC usage patterns within small manufacturing firms. The study further examined the extent of the awareness of ABC within manufacturing SME's as well as of the benefits derived from implementing this system, identify the perceived barriers impeding the ABC adoption and identify the reasons why manufacturing SMEs are still very skeptical about implementing ABC.

THEORETICAL BACKGROUND

Increasing competitiveness worldwide has prompted manufacturing firms to seek to provide high quality products more quickly at a competitive cost. Over the past decades, the paradigm of ABC has assisted many manufacturing and service firms improve their competitiveness by allowing them to make better decisions based on better understanding of their cost structure. It has been asserted that Activity-based costing is a process of listing and measuring the cost of each product or service individually. It was developed to try and overcome the limitations of the volume based traditional costing systems. ABC was developed in order to assist the managers with accurate product cost information. According to Raiborn and Kinney (2012) ABC focuses on the organisation's activities and collects costs on the basis of the underlying nature and extent of those activities. Drury (2014) posit that ABC provides firms with an economic map of their environmental activities which leads to profitability of individual products and services. Managers usually recognise the need for a costing system such as ABC when they are experiencing increased lost sales due to erroneous pricing resulted from incorrect costing data (Blocher, Chen & Lin, 2005). Blocker et al. (2005) further pointed that ABC recognizes the causal or direct relationship between resource costs, cost drivers, activities and cost objects in assigning costs to activities and to the cost objects. They reiterated that it also focusses on attaching costs to products and services based on the activities conducted to produce, perform, distribute and support those products and services.

In order to reach these goals, manufacturing companies are required to become more flexible, integrated and highly automated. However, without a realistic and more accurate cost calculation mechanism, these systems cannot be expected to sustain competitiveness (Ozbayrak, Akgun & Turker, 2004). In support, Braun, Tietz and Harrison (2010) pointed that implementing ABC helps in cutting costs and in routine planning and control decisions. Furthermore, Quinn, Elafi and Mulgrew (2017) confirmed that ABC provides better costing information and also assists management manage efficiently and gain a better understanding of the firm's competitive advantage. Similarly, ABC can be used for cost reduction, activity-based budgeting, performance measurement, process management and business reengineering (Drury, 2014). Ozbayrak et al. (2004) further pointed out that ABC

improves visibility of costs and as a result it is a valuable information tool that provides management with unrivalled insight into the workings of the manufacturing system.

Benefits of using ABC

Previous research has indicated that ABC is a feasible and viable method for establishing profitability for businesses. According to Blocher, Stout, Cokins and Chen (2008), ABC provides more accurate product and customer profitability measurements and better informed strategic decisions about pricing, product lines and market segments. Firms are provided with a way to improve performance evaluation by providing estimates of the cost of satisfying sales to which a sales representative may agree. Jankala and Silvola (2012) posit that with ABC, managers are assisted in their operative decision-making and management as well as helping them to focus on the profitable products in generating growth. Furthermore, ABC provides a clear view of how a firm's diverse products, services and activities contribute to the firm's bottom line and also assists firms in increasing value delivered to customers. Cannavacciuolo, Illario, Ippotito and Ponggliome (2015) posit that ABC can be used for cost reduction, performance measurement, benchmarking of activities, process management and business reengineering as well as identifying reengineering parts, distinguishing between incremental and radical ones.

Furthermore, Kalicanin and Knezevic (2013) report that with ABC, the quality and diversity of information contributes to the effectiveness of decision-making and it also provides an information basis for permanent cost reduction. They further reiterated that ABC is not only a new approach to cost accounting, but also a precondition for a more quality and modern way of managing a firm. Haroun (2015) confirmed that by using ABC, firms can gain more accurate cost estimates than the traditional costing methods. In support, Baykasoglu and Kaplanoglu (2008) pointed that ABC provides detailed cost estimation and supports forward decision-making. Research conducted by Krumwiede and Charlse (2014) revealed a positive impact on profit performance when ABC is used.

Barriers of ABC

Although ABC offers better information for product costing than the traditional costing systems, it still has its pitfalls. The barriers that impede the adoption of ABC by many companies to mention but a few are the organisational barriers which relate to territorial or corporate culture issues; environmental barriers that are built by employee groups, regulatory agencies or other stakeholders of interest and individual barriers that are related to fear of the unknown or shift in status quo. According to Nassar, Alkhadash, Sangster and Mah'd (2013), an ABC system is very expensive and time consuming to develop and implement. Managers of small manufacturing firms may be overwhelmed by the time and effort required to develop an extensive ABC system (Roztockki et al. 2004). Fei, Hoque and Isa (2015) conducted research and examined the interactive effects of organizational culture and structure on the success of implementing ABC in Chinese manufacturing firms. Their findings revealed that organizational culture, outcome orientation and attention to detail are significantly associated with the success of implementing ABC. Lack of top management support and resistance to change usually impede the ABC adoption.

Hypothesis

Since it is very costly and requires the right skills and expertise to implement ABC, it is therefore expected that the differences in the firms' profiles such as the size play an important role when a decision has to be made on whether to adopt ABC or not. The first hypothesis is stated in this regard:

H₁: *There are no mean differences in the size (number of employees) of ABC implementers and those who did not.*

The firms who have implemented ABC have more experiences than those who did not adopt ABC. It can therefore be hypothesized that perception regarding barriers to ABC adoption is different between the ABC adopters and the non-adopters. The second hypothesis is stated in this regard

H₂: *There are no differences between the barriers perceived to be impeding the adoption of ABC for ABC user and for non-ABC users.*

Problem statement

Since its inception in the 1980's, ABC adoption has grown significantly in large manufacturing firms and less frequent is the development and implantation of ABC in small firms. Despite the significant opportunities that ABC offers small manufacturing firms, it has received little attention from most small manufacturing SME's. The gap/problem identified in the literature is that ABC is investigated in small enterprises only to a very limited extent.

In spite of the interest amongst practitioners and academics, recent surveys document the slow diffusion of ABC in practice. Research on ABC and its applications has been focused mainly on firms in developed countries and on large firms. Little has been learnt in firms in developing countries (Liu & Pan, 2007) as well as on small firms. Gosselin (2007) as quoted by Somapa, Cools and Dullaert (2012) pointed that very few firms employ ABC and a significant number of ABC adopters do not actually implement it. Similarly, despite the significant opportunities that ABC offers small manufacturing firms, it still continues to receive little attention from these small firms.

In view of the fact that there is little evidence of research conducted to determine the extent of ABC awareness in the small manufacturing firms in South Africa, the thrust of this paper is to investigate or to examine the ABC usage patterns, identify the extent of awareness of ABC within the small firms; identify the barriers impeding its adoption and to determine the reasons why small firm are still skeptical to implement the system. The firms who have not implemented the system are given the platform to share the reasons for their decision in this regard.

RESEARCH DESIGN

A quantitative research design was followed in gathering data at different selected small manufacturing firms operating in the Southern Gauteng Region of South Africa. Quantitative survey method was utilized and questionnaires were administered by trained interviewers. For this study however, a convenience sampling method was used. This is a method of selecting haphazardly or in unstructured manner those cases that are easiest to obtain from the population frame (Welma, Kruger & Mitchell, 2015). This method was chosen because respondents can be reached easily, costs can be kept to a minimum and most importantly it is useful in exploratory research to get a quick approximation of the truth (Maree, 2015). A sample of 80 small manufacturing firms was selected according to a list obtained from Vaal Information directory.

Data Collection

The data was collected by means of structured questionnaires that were hand-delivered to the owners/managers/finance staff of small manufacturing firms operating in the Southern Gauteng region. For this study, a convenience sample, sometimes called grab or opportunity sampling was used. Its main disadvantage is that it is classified as non-probability sampling, because elements in the population are included since they are easily and conveniently available, but not necessarily representative of the population (Maree, 2015). Therefore, convenience sampling is the method of choosing items in an unstructured manner from the population frame. However, it is chosen because respondents can be reached easily, costs can be kept to a minimum and most importantly, it is useful in exploratory research to get a quick approximation of the truth (Maree, 2015). The questionnaire was divided into three sections. Section A focused on the demographic information including company profile; Section B investigated the perceived barriers impeding ABC adoption and Section C focused on those firms that have not adopted ABC and the reasons for not implementing ABC. The questionnaire utilized a 5-point Likert scale and respondents were instructed by the researcher during the administration of the questionnaire to encircle the most suitable answer. The scale ranged from 1 to 5 as follows:

- 1 Strongly Disagree
- 2 Disagree
- 3 Neutral
- 4 Agree
- 5 Strongly Agree

A sample of 80 small manufacturing firms operating within the Southern Gauteng Region was selected according to a list obtained from the Vaal Information Directory (2016). A fairly good 50 respondents completed the questionnaire, which represents a response rate of 63%. Of the respondents, 34 respondents indicated that they have not adopted ABC and 16 indicated that they have adopted the system.

Data Analysis

Data was analysed using the Statistical package for Social Sciences (SPSS) version 24.0. Frequency analysis, descriptive statistics and reliability tests were carried out. The Cronbach Alpha coefficient was used to measure internal reliability of the measuring instrument. The Cronbach Alpha coefficient is 0.71. The questionnaire was found to be valid and reliable since the Cronbach Alpha coefficient was above 0.70 (Gwet, 2014). The averages of the firms' perceptions on the barriers impeding ABC adoption for the firms who implemented ABC were compared with those firms that did not implement the system. The t-test was carried out to determine whether the differences between the two groups' means is significant.

The main aim was to identify perceived barriers impeding its adoption and also to determine the reasons why some firms do not adopt this method at all. All the questions in the questionnaire were presented in a closed format and no open ended questions were posed. The researcher compared the means of the perceived barriers for the firms who implemented ABC with the firms who did not adopt ABC. The t-test, which is suitable for smaller samples (Swanepoel, Swanepoel, Van Graan, Allison & Santana, 2010) was performed to determine whether the differences between these two independent group's means are significant. The F-test was first performed to determine whether a t-test, assuming equal variances, or a t-test, assuming unequal variances, should be run (Arthur, 2009).

A null-hypothesis stated that there is no difference between the mean values of these two sets of data. A significant level of $p < \alpha = 0.05$ is used, implying that $p < 0.05$ assumes unequal variances and $p > 0.05$ assumes equal variances. Since this is a two-sided approach, the two-tailed values were used in the statistical analysis. The t-test was based on the significant levels, where $p < \alpha = 0.01$ and $\alpha = 0.05$ respectively (two-tailed). This implies that there is overwhelming and strong evidence, respectively that the null-hypothesis should be rejected in favour of the alternative hypothesis. Where $p > \alpha = 0.05$, the null-hypothesis will not be rejected since there is weak or no evidence to accept the alternative hypothesis (Wegner, 2010).

Findings of the study

The findings of the questionnaire are presented under the following; first, the difference in firms' profiles, second, the difference in perceptions of barriers to adopting ABC between firms who implemented ABC and those who did not and the reasons given by the firms who did not adopt the system.

Table1: Difference of firms' profiles between users and non-users of ABC

Users (n=16)	Age	Size
Mean	4.500	67.688
Std dev.	0.516	18.180
non-Users (n=34)		
Mean	4.094	43.875
Std dev.	0.641	17.277
F-test		
p-value	0.190	0.390
t-test		
p-value	0.033	<0.001
Significance	**	***

** Significant at 5% and *** significant at 1% (two-tailed)

Company Profile-General questions. The respondents were requested to indicate the size of their firms in terms of the number of employees. Table 4.1 indicates that the ABC users had an average of 67.688 employees and the non-users 48.875 employees. The ABC users employ between 41 and 96 employees while the non-users employ between 17 and 78 employees. To test the first null-hypothesis (H1), there is no difference in the size (number of employees) of businesses who have implemented ABC and those who have not; there is overwhelming evidence that the null-hypothesis should be rejected. This is because the size of the firms who implemented ABC is significantly larger than those who did not.

Table 2: Difference between users' and non-users' perceptions of barriers impeding ABC adoption

Users (n=16)	C1	C2	C3	C4	C5	C6	C7	C8	C9	C10	C11
<i>Mean</i>	4.375	4.000	4.438	4.250	2.875	3.125	3.313	2.875	2.875	4.375	2.938
<i>Std dev.</i>	0.885	0.730	0.814	0.775	1.147	1.025	0.793	0.885	0.885	0.806	0.250
Non-users (n=34)											
<i>Mean</i>	4.656	4.063	4.500	4.625	3.281	3.281	4.031	3.781	3.813	4.625	3.719
<i>Std dev.</i>	0.483	0.504	0.508	0.492	0.813	0.772	0.595	0.491	0.535	0.492	0.523
<i>F-test</i>											
<i>p-value</i>	0.002	0.040	0.013	0.016	0.051	0.089	0.086	0.003	0.009	0.010	0.002
<i>t-test</i>											
<i>p-value</i>	0.250	0.761	0.781	0.092	0.163	0.557	0.001	0.001	0.001	0.268	0.000
<i>Significance</i>							***	***	***		***

** Significant at 5% and *** significant at 1% (two-tailed);

C1=High cost of implementing ABC, C2=Resistance to change, C3=Involves a great deal of work, C4=It is time consuming, C5=Lack of top management support, C6=Lack of cooperation and commitment among departments, C7=Lack of knowledge concerning ABC, C8=Problems defining cost drivers, C9=Problems in identifying cost drivers, C10=High costs of consultations, C11=A high priority of other changes or projects

Table 2 indicates that the null-hypothesis should be rejected in four cases because there is a significant difference between the ABC users' perceptions and non-ABC users' perceptions regarding the barriers impeding the adoption of ABC by firms. The non-ABC users have higher mean scores than ABC users, thus implying that they agree more to the following barriers: problems in defining cost drivers, problems in identifying activities, lack of knowledge concerning ABC and that there is higher priority given to other changes or projects. For the rest of the

statements in section C, the null hypothesis should not be rejected, implying that there is no significant difference between the perceptions of ABC users and non-ABC users.

Table 3: Reasons Firms Have Not Adopted ABC

N	Rank	Mean	% Agree	% Disagree	% Neutral	Description
30	1.	4.87	100			<i>Too expensive to implement</i>
30	2.	4.57	100			<i>Lack of adequate systems</i>
30	3.	4.50	100			<i>Too detailed/time consuming</i>
30	4.	3.80	80	13	7	<i>Lack of skills/knowledge of ABC</i>
30	5.	3.23	33	10	57	<i>Difficulty defining cost pools, cost drivers</i>
30	6.	3.20	27	6	67	<i>Difficulty identifying suitable cost drivers</i>
30	7.	3.20	33	14	53	<i>Difficulty with data gathering</i>
30	8.	3.13	100			<i>Difficulty configuring ABC with other systems</i>
30	9.	3.03	17	13	70	<i>Inadequate marketing of ABC</i>
30	10.	2.63	17	40	43	<i>Satisfaction with current system</i>
30	11.	2.43		43	57	<i>Does not add value</i>
30	12.	2.23		57	43	<i>Negative publicity about ABC</i>
Average		3.5	51%	16%	33%	

Table 2 indicates that the first four statements had the highest mean values. These high mean scores indicate that the respondents highly agreed that ABC is too expensive to implement, they do not have adequate systems to implement it, it is too detailed and time consuming and they lack skills and knowledge of ABC.

Discussions and conclusions

The findings revealed that ABC users have been in business for a longer period of time than the non-users and the non-users' main reasons for not adopting ABC are lack of ABC knowledge and skills, high cost of implementing ABC and lack of adequate systems. This implies that a small manufacturing firm needs time to grow in order to be able to overcome these obstacles for not implementing ABC. The fact that ABC users' firms are larger than non-users' firms implies that larger firms are probably in a better financial position to afford such a system.

The findings of this paper further reveal that most of the small firms in South Africa are being prevented from adopting and implementing ABC due to the high cost of consultations, high cost of implementation, lack of knowledge and skills and resistance to change by the employees. However, the non-users should bear in mind that these barriers, (lack of ABC knowledge, problems in defining cost drivers, problems in identifying activities and the higher priority of other changes or projects) should not be as much of a problem they believe them to be. In addition, the respondents expressed the opinion that there is lack of top management commitment and support to implement ABC so they feel demotivated. The findings generally indicate that the majority of the small firms are still using the old traditional costing methods.

The results for this study are consistent with the findings of Garrison et al. (2008), Majid and Sulaiman (2008) who propagate that the initiative to implement ABC must be strongly supported by top management. The reason for insisting on strong top-management support is rooted in the fact that it is difficult to implement changes in organizations unless those changes have the full support of those who are affected. They reiterated that without leadership from top management, some managers may not see any reason to change and if top management do not support the ABC system and continue to evaluate and reward employees based on traditional cost data, their subordinates will quickly get the message that ABC is not important and they will abandon the ABC initiative. Majid and Sulaiman (2008) confirmed that top management should encourage the implementation of ABC by providing suitable guidance, motivation and financial and technical support. Furthermore, they stated that people from all departments should be involved in the initial design of ABC systems so as to motivate the employees with a sense of responsibility for implementing ABC, to ensure an improved competitiveness for the organization. This will help curb resistance to change amongst the employees.

Gunasekaran and Sarhadi (1998) reiterated that the employees of the organization should be equipped with the knowledge of ABC and the benefits that could be derived from them. Gunasekaran et al. (1999) confirmed that full understanding, commitment and leadership of an organization is a crucial factor when implementing ABC. They also reported that the employees must have a clear understanding of ABC principles, capabilities, goals and objectives. This understanding will make it possible for the expectation of ABC in small manufacturing firms to be communicated appropriately to all the employees. Furthermore, the results confirm the findings of Chongruksut (2002), Chongruksut and Brooks (2005) who posited that training is important in assisting people to understand the difference between ABC and traditional costing systems and why ABC provides superior economic and information systems. Managers of small firms are often overwhelmed by the time and effort required to develop an extensive ABC system. This is confirmed by Roztocki *et al.* (2004).

Recommendations

The findings have significant implications for companies or firms that would want to adopt ABC. The problems/barriers highlighted may assist firms planning to implement ABC in the near future to better address these issues. It is however clear from the above mentioned results that the implementation of ABC requires that a firm be well-established, with sufficient funds and the knowledge of the ABC concept. It has also been revealed that the ABC users are to some extent more positive towards ABC than the non-users. Therefore, the recommendation is that, since firms are unique, they should perform a cost-benefit analysis to determine whether it will be worthwhile implementing ABC.

Limitations of the research

The findings of this study should be viewed with certain limitations in mind. These limitations, however present opportunities for future studies.

Firstly, the scope of the study is limited by the sample size which included only the owners/ managers/ finance staff of the small manufacturing firms. The findings of this study may have been different if a broader range of employees within the companies and not only owners/ managers/ finance staff had been selected. Secondly, the number of respondents who possessed ABC knowledge was very small. It was a bit of a challenge to conduct meaningful statistical tests. The results may have been different if the number of respondents with ABC knowledge had been higher and if the response rate was also higher. Thirdly, the level of ABC knowledge among the respondents was average. In some cases, the researcher had to give an explanation of ABC in order for them to understand what the questionnaire meant. Fourthly, the researcher, due to the financial constraints was unable to carry out interviews and interact with respondents in order to eliminate misinterpretations of various questions which have a bearing on the results. Finally, another limitation is the unwillingness or sensitivity of respondents to disseminate or divulge the company information. They were only relaxed after assuring them that the information collected was to be treated with utmost confidentiality.

Opportunities for future research

The study is not a full representation of all the small to medium manufacturing firms operating within the Southern Gauteng region. It is expected that the results pertaining to ABC might differ if a broader study were to be undertaken that covered all the small to medium manufacturers in Southern Gauteng and if, in addition, this was extended to cover the greater Gauteng region. Research could be carried out into other small to medium firms that are not into manufacturing only but service industries or retail industries in order to generalize findings to a wider South African business environment. Further research can also be conducted to determine the impact of ABC on the financial performance of small firms in the greater Gauteng region. Further studies should also focus on the cost-benefit analysis of ABC in small manufacturing firms in order to guide these firms in the decision-making process whether ABC should be implemented or not.

REFERENCES

- Athur, J. (2009). To test two samples assuming equal variances in Excel. [Online] Available at <http://www.qimacros.com/qiwizard/t-test-two-sample.html> Accessed: June 22nd, 2016.
- Baykasoglu, A & Kaplanoglu, V. (2008). Application of activity-based costing to a land transportation company: A case study. *International Journal of Production Economics*, 116:308-324.
- Blocher, E., Stout, D.E., Cokins, G. & Chen, K. (2008). *Cost management: A strategic emphasis*. New York: McGraw-Hill.
- Blocher, E.J., Chen, K, & Lin, T.W. (2005). *Cost management: A strategic emphasis*. 3rded. New York: McGraw-Hill/ Irwin.
- Braun, K.W., Tietz, W.M. & Harisson. W.T. (2010). *Managerial accounting*: 2nd ed. New York: Prentice Hall.
- Cannavacciuola, L., Illario, M., Ippolito, A. & Ponsiglione, C. (2013). An activity-based costing approach for detecting inefficiencies of healthcare processes. *Business Process Management Journal*, 21(1):55-79.
- Chongruksut, W & Brooks, A. (2005). The adoption and implementation of activity-based costing in Thailand. *Asian Review of Accounting*, 13(2):1-17.
- Chongruksut, W. (2002). The adoption of activity-based costing in Thailand. Unpublished Doctoral research. School of Accounting finance. Victoria University.
- Drury, C. (2014). *Management and cost accounting*. 7th ed. South African edition. Hampshire: South-Western Cengage Learning.
- Elliot, R. & Boshoff, C. (2007). The influence of the owner-manager of small tourism business of internet marketing. *South African Business Journal*, 38(3):15-27.
- Garrison, R.H., Noreen, E.W. & Brewer, P.C. (2008). *Managerial Accounting*. 12thed. New York: McGraw-Hill/ Irwin.
- Gunasekaran, A. & Sarhadi, M. (1998). Implementation of activity-based costing in manufacturing. *International Journal of Production Economics*, 56-57:231-242.
- Gunasekaran, A. & Singh, D. (1999). Design of activity-based costing in a small company: A case study. *Computers and Industrial Engineering*, 37:413-416.
- Gwet, K.L. 2014. Handbook of inter-rater reliability. The definitive guide to measuring the extent of agreement among raters. 4th ed.
- Haroun, A.E. (2015). Maintenance cost estimation: Application of activity-based costing as a fair estimate method. *Journal of Quality in Maintenance Engineering*, 21(3): 258-270.
- Jankala, S., & Silvola, H. (2012). Lagging effects of the use of activity-based costing on the financial performance of small firms. *Journal of Small Business Management*, 50(3):498-523.
- Kalicanin, D. & Knezevic, V. 2013. Activity-based costing as an information basis for an efficient strategic management process. *Economic Annals*, 58(197): 95-119.

- Krumwiede, S.R. & Charlse, S.L. (2014). The use of activity-based costing with competitive strategies: Impact on firm performance. *Advances in Management Accounting*, 23:113-148.
- Liu, L.Y.J. & Pan, F. 2007. The implementation of Activity-Based Costing in China: An Innovation action research approach. *The British Accounting Review*, 39: 249-264.
- Majid, J.A. & Sulaiman, M. (2008). Implementation of Activity-based costing in Malaysia: A case study of two companies, 16(1):39-55.
- Maree, K. (Editor). (2015). *First steps in research*. Pretoria: Van Schaik.
- Merchant, K.A. & Van Der Stede, W.A. (2007). *Management control systems performance measurement, evaluation and incentives*. Essex: Prentice- Hall.
- Mortaji, I.S, Baghepour, M & Mazdeh, M.M. (2013). Fuzzy Time-Driven Activity-Based Costing. *Engineering Management Journal*, 25(3):63-73.
- Nassar, M., Al-Khadash, H.A., Sangster, A & Mah'd, O. (2013). Factors that catalyze, facilitate and motivate the decision to implement activity-based costing in Jordanian industrial companies. *Journal of Accounting Research*, 14(1):18-36.
- Ozbayrak, M., Akgun, M. & Turker, A.K. (2004). Activity-based cost estimation in a push/pull advanced manufacturing system. *Journal of Production Economics*, 87:49-65.
- Quinn, M., Elafi, O & Mulgrew, M. (2017). Reasons for not changing to Activity-based costing: A survey of Irish firms. *Research Review*, 1(1): 63-70.
- Raiborn, C.A, & Kinney, M.R. (2012). *Cost accounting: Foundations and evolutions*. Mason: South Western/ Cengage Learning.
- Roztocki, N., Porter, J.D., Thomas, R.M. & Needy, K.L. (2004). A procedure for smooth implementation of activity-based costing in small companies. *Engineering Management Journal*, 16(4):19-27.
- Sandino, T. (2007). Introducing the first management control systems: Evidence from the retail sector. *The Accounting Review*, 82(1):265-293.
- Somapa, S, Cools, M & Dullaert, W. (2012). Unlocking the potential of time driven activity-based costing for small logistics companies. *International Journal of Logistics Research and Applications*, 15(5): 303-322.
- Swanepoel, J.W.H., Swanepoel, C.J., Van Graan, F.C., Allison, J.S. & Santana, L. (2010). *Elementary statistical methods*. Potchefstroom: AndCorp.
- Wegner, T. (2010). *Applied business statistics: Methods and Excel-based applications*. Cape Town: Juta.
- Welma, C., Kruger, F. & Mitchell, B. (2015). *Research Methodology*. 3rd ed. Cape Town: Oxford University Press.
- Y Fei, Z, Hoque, Z & Isa, C.R. (2015). The effects of organizational culture and structure on the success of activity-based costing implementation. *Advances in Management Accounting*, 25:229-257.

HABIT FORMATION TO SUPPORT THE CONTINUANCE USAGE OF LINE APPLICATION

Pichita Sansuwan and Supeecha Panichpathom
Thammasat University, Thailand

ABSTRACT

At the present, the technology makes people communicate more conveniently and rapidly to each other and narrows the gap between the senders and receivers because we can use communication technology anywhere and anytime with various devices and application. For example, people widely use one of popular communication application called Line. This Line application is free of charges; however, Line provider might want to increase its market size by encouraging people to use line continuously. This research thus, aims to analyze the habit formation to support using Line application continuously and focuses on post acceptance behavior based on Post-Acceptance Model of IS Continuance prior research studies. Main two issues are (1) Factors that influence habit in using line application. (2) How Habit in Using Line and User Satisfaction influence Line Continuance Usage. Factors, in study are Familiarity, Perceived Monetary Value, Perceived Usefulness, User Satisfaction, Habit in Using Line and Line Continuance Usage. This research is a quantitative study employed online questionnaire as a device of data collection. Valid 280 respondents are Line application users in Thailand. There are representative samples of this research. The result from performing the PLS-SEM for the analysis reflects that (1) Perceived Monetary Value factor and User Satisfaction factor influence the habit in using line, however, User Satisfaction influence the habit in using Line more than Perceived Monetary Value. (2) Habit in Using Line factor has direct effect to Line Continuance Usage and User Satisfaction has indirect effect on Line Continuance Usage via the Habit in Using Line, however, the result of direct effects are greater than the result of indirect effects. Consequently, for the sake of Line continuance usage, the habit in using Line is important issue. If Line application service provider is aware of factors that influence the habit in using line, they can design and develop functions of Line application that accord with the habit formation of users.

Keywords: Line Continuance Usage, Habit in Using Line, Perceived Monetary Value, User Satisfaction, Perceived Usefulness, Familiarity

INTRODUCTION

Nowadays, the usage of the Internet is widely to support daily life activities and work activities. Nielsen (Thailand) collected data pertaining to the behavior of Thai people in using the smart phones during November 2015 to December 2016 and reported three noticeable issues. First issue is every Thai people want to own smart phones. The proportion of the owners of smartphones grew from 49 percent to 58 percent. Second issue is there is a growth in the Internet traffic and the last one is 25 percent of Thai people spend their time after waking up on using smart phones to communicate and to entertain themselves. This last issue is in line with the results conducted by Thai Office of Electronic Transactions during year 2016. The most activities of smart phones users with the Internet are communication via the social network, such as Facebook, Instagram and Line. These activities are account to 82.7 percent. In addition to these behaviors, Nielsen (Thailand) reported that the most widely used application for social networking for Thai people is Line Application. On average, Thai people spend about 74 minute per day with Line Application.

Due to the growth of the Internet traffic and of the number of Line users in Thailand, which has the second rank in the world, we want to gain the insight of this continuance usage of Line application. However, from the

previous studies, the continuance usage could be obtained from continuance usage intention)Bhattacharjee, 2001(or users' habit)Kim, Malhotra & Narasimhan, 2005; Limayem, Hirt, & Cheung, 2007; Ouelette & Wood, 1998(. Moreover, most previous research studies in this context focused on continuance usage intention rather than on habit. This study, thus, wants to analyze factors influence the habit formation and lead to continuance usage of Line.

LITERATURE REVIEW

Perceived Usefulness, Familiarity, User Satisfaction

Perceived usefulness of IS is the degree to which a person believes that using IS will improve his/her job efficiency)Davis, 1989(. According to Post-Acceptance Model of IS Continuance, the expectation after the usage is turned into perceived useful after the usage. Varied previous research studies identified that this perceived usefulness was main factor influencing information technology)IT(acceptance)Bhattacharjee, 2001(and the predictor of users' satisfaction and of IS usage)Hong, Thong, & Tam, 2008(; Thong, Hong, & Tam, 2006(.

Familiarity is the state of having knowledge about something or doing something. This knowledge comes from the repeated interaction, the experience and the learning of users)Gefen, 2000; Komiak, & Benbasat, 2006; Gefen, Karahanna, & Straub, 2003(. Previous IS research studies applied the familiarity to website users, such as Amazon.com. The result showed that the familiarity with the purchasing process of this website increased the willingness to purchase products on that website)Gefen, 2000(.

Satisfaction is a feeling of how well the expectations of a customer relating to received products or services. Satisfaction in IS usage is a factor influencing IS continuance usage)Bhattacharjee, 2001; Thong et al., 2008(. For example, Limayem & Cheung)2008(found that users' satisfaction was a predictor of continuance usage of Internet-based learning technology.

Perceived Monetary Value

Perceived monetary value is the difference between the price paid to an offering and the perceived worth. This value is applied to the usage of the services in terms of related costs and benefits)Dodds, Monroe, & Grewal, 1991(. Marketing research studies suggest that the price of products is a factor pertaining to the evaluation of product quality. Customers will purchase products when they feel the worth of paid money comparing to the price of the received products)Kranz, 2012(. Many research studies, pertaining to data services and applications services via smart phones, applied this perceived monetary value to their studies. They found that users had to bear expenses in using the services therefore the perceived monetary value is one of the factor they consider when they made the purchase decision in this context)Kim, 2011; Hong & Tam, 2008; Thong, Thong, Moon, & Tam, 2008(.

Habit

Usage habit is something that people do often and regularly, which is unconscious pattern of actions obtained from repetition. Habit, thus, is the act turning from gradually learning into automatic responses to a given phenomenon and it also leads to goals fulfillment)Verplanken, Aarts, & Knippenberg, 1997(. Habit formation is caused by doing something in repeated contexts. This behavior occurs with the minimum intention of the actors in order to respond to given situations)Limayem et al., 2007(or the behavior occurs frequently but without conscious)Kim, 2011(and leading to automatic acting)Ouelette, & Wood, 1998; Limayem et al., 2007; Orbell, Blair, Sherlock, & Conner, 2001(. Previous studies, pertaining to the mobile data service and application, indicated that usage habit was a good predictor of continuance usage behaviors)Kim, 2011(.

Continuance Usage

Post-Acceptance Model of IS Continuance has been applied to varied IS research studies, however, one of main factors, which influence IS continuance usage might not be conscious intention to use but be the habit (Kim, Malhotra, & Narasimhan, 2005; Limayem et al., 2007). IS continuance usage, thus, explains behavior patterns of IS continuance usage in a long-term period (Limayem et al., 2007).

RESEARCH MODEL

Hypotheses

As described above, there are quite few research studies, which analyze the role of habit on continuance usage. The habit of using something, such as Line, and the satisfaction users have will influence continuance usage. In this study, we, therefore, concentrate on four antecedents, which are perceived usefulness, familiarity, perceived monetary value, and habit, and one consequence, which is continuance usage, of habit (Figure 1).

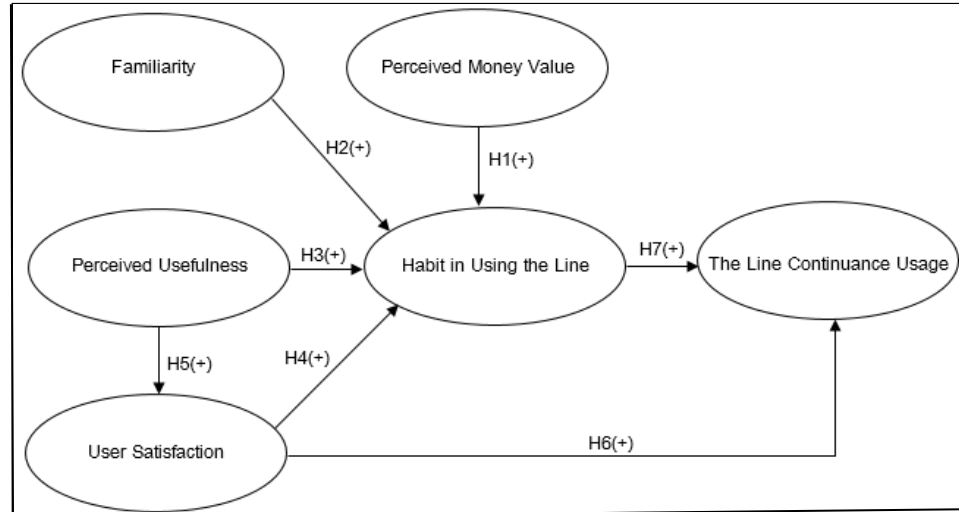

Figure 1: A Framework for Predicting Line Continuance Usage

In marketing discipline, customers usually evaluate the product or service prices by comparing to its quality (Kranz, 2012). The satisfaction of users is the response of their emotion and feeling occurred after having products and services and can judge that it is worth the paid money or not (Lam, Shankar, Erramilli, & Erramilli, 2004; Oliver, 1993). This emotion response is a main factor in forming the habit of using data service and applications via smart phones, such as Line application, voice call, video call. If customers feel the use of those applications worth money, they tend to return to use them repeatedly and this behavior will turn into the habit (Kim, 2011). Thus the first hypothesis is as follows.

H 1: *The higher perceived monetary value Line users have, the higher level of their habit in Line usage.*

Main characteristic of forming the habit is the learning relationship between behaviors of users and satisfaction or usage experiences. For example, since customers have online business transactions via e-commerce website, they have learned the online process and get used to do it or automatically do it (Morrison & Firmstone, 2000, Wood, Quinn, & Kashy, 2002). The second hypothesis is as follows.

H 2: *The higher familiarity Line users have, the higher level of their habit in Line usage.*

According to the Technology Acceptance Model (TAM), users will accept technology when they believe that technology has positive efficiency (Davis, 1989). Therefore, users who often use technology will finally turn this behavior into the habit or automatic behavior. In sum, the habit includes behaviors which act frequently and in a stable context (Limayem et al., 2007). This leads to the third hypothesis.

H 3: *The higher perceived usefulness Line users have, the higher level of their habit in Line usage.*

Satisfaction is a feeling of users after using something for a while and their usage experiences fulfill their initial expectation (Bhattacharjee, 2001). Satisfied experiences in using something is an important key to form the habit of doing something frequently under the same situations (Limayem et al., 2007; Aarts, Paulussen, & Schaalma, 1997; Hsiao et al., 2015). This leads to the fourth hypothesis.

H 4: *The higher satisfaction Line users have, the higher level of their habit in Line usage.*

When users have good beliefs toward the efficiency of the usage, their perceived usefulness level will be higher. The alignment between usage behaviors and their initial expectation influences users' satisfaction (Bhattacharjee, 2001). In sum, perceived usefulness is a predictor of users' satisfaction and IS usage intention (Hong et al., 2008; Thong et al., 2008; Oghuma, Libaque-Saenz, Wong, & Chang, 2015). Previous studies pertaining to Instant Messaging (IM) services suggested that users expect to gain benefits of IM usage, such as, having as a communication tool to chat with their family, friends and colleagues (Oghuma et al., 2015; Ajjan, Hartshorne, Cao, & Rodriguez, 2014) or to reduce travelling time and communication time by using it anywhere and anytime (Ha, Kim, Libaque-Saenz, Chang, & Park, 2014). If users achieve their expected benefits, they will gain satisfaction. Thus, the next hypothesis is as follows.

H 5: *The higher perceived usefulness Line users have, the higher level of their satisfaction.*

Marketing research studies indicated that users' satisfaction is one of the important and interesting construct (Limayem & Cheung, 2008). Customers who have higher level of satisfaction will utilize products or services more often than customers with lower level of satisfaction (Bolton & Lemon, 1999). When users are satisfied with products or services they will increase usage level (Limayem & Cheung, 2008). Thus the sixth hypothesis is as follows.

H 6: *The higher satisfaction Line users have, the higher level of their continuance usage.*

Habit is repeated behavior pattern which automatically occurs or unconsciously occurs (Kim, 2011). Previous studies suggested that usage habits, related to continuance usage, is more powerful than usage habits with intention to continuance usage (Ouellette & Wood, 1988; Kim, 2011). In sum, usage habit is derived from repeated actions and under the same situations or contexts. This habit is a good predictor of continuance usage behavior too (Kim, 2011). Thus the last hypothesis is as follows.

H 7: *The higher level of usage habit Line users have, the higher level of their continuance usage.*

Research Design

This study is a survey quantitative research employed online questionnaire to collect data from people who have the experience in using Line. Total valid respondents are 280. The sampling of respondents is a convenient method. Before distributing final questionnaire by Google Doc, we perform pilot test with 50 samples.

Questionnaire is composed of three parts. The first part is questions relating to behaviors of Line usage. The next part includes questions pertaining to all six constructs, namely, perceived usefulness, satisfaction, familiarity to the use of Line, perceived monetary value, usage habit and continuance usage (Table 1). All constructs use five point Likert scale whereas 1 is the least agreement and 5 is the highest agreement.

Data processing and hypotheses tests are performed with PLS-SEM by using SmartPLS 3.0. First part of data analysis is the descriptive statistics explaining the profiles of all valid respondents. Second, we evaluate

Table 1: Measurement Items Used in this Study

Construct	Item	Reference
Perceived Usefulness (PCU)	1. Using the Line helps me save communication time.	Davis (1989)
	2. Using the Line increase the effectiveness of my communication.	Davis (1989)
	3. Using the Line helps me achieve the communication rapidly.	Davis (1989) and Kim (2011)
	4. I find that the Line is useful for my communication.	Davis (1989)
	5. Using the Line ease my communication methods.	Davis (1989)
Familiarity (FML)	1. I understand and know how to use functions and features of the Line very well, for example, how to add friends with ID or QR code.	Chiu et al.(2012)
	2. I understand and know how to use the Line to text the message.	Chiu et al.(2012)
	3. I understand and know how to use video call with the Line.	Chiu et al.(2012)
	4. I understand and know how to use voice call with the Line.	and Gefen et al.(2003)
	5. I understand and know how to use the Line to search the name of people whom I want to communicate to.	
	6. I understand and know how to use the Line to receive and send files such as document files, image files and voice files.	
Perceived Money Value (PCM)	1. The Line is valuable application and it is free of charge.	Dodds et al.(1991) and Kim (2011)
	2. For me, we should use the Line application.	Dodds et al.(1991)
	3. Using the Line is worth my efforts and time spending to use it.	Kim (2011)
	4. The Line is the application that is worth to use	
	5. Comparing to other free communication, such as the WhatsApp, the Line is the application that is worth to use for communication.	Pura (2005)
User Satisfaction (USS)	1. My use experience with the Line is good, for example, I can talk to, communicate to, post message and express the opinions to others.	Hsu et al.(2014)
	2. I am delighted to use the Line.	Zhou, Lu (2011)
	3. Using the Line makes me happy.	
	4. I feel good about the decision to use the Line to talk to others.	Hsu et al.(2014)
	5. Talking to others with the Line group is a good idea.	
Habit in Using the Line (HAB)	1. I am not hesitated to use the Line to talk to someone else.	Limayem et al.(2007)
	2. When I want to talk to my colleagues as a group, I use the Line as the first choice of communication.	Kim (2011) and Limayem et al.(2007)
	3. When I want to express or request the opinions from the group, I use the Line as a first choice in posting issues and expressing the comments on that issue.	
	4. I use the Line without a thought to communicate with other people.	Hsu et al.(2014)
	5. I commonly stick to using the Line.	Limayem and Hirt (2003)
The Line Continuance Usage (CNU)	1. Overall, on the average, how often do you use the Line.	Kim (2011) and Teo et al.(1999)
	2. During the period of one month, on average, how much time do you spend on the Line.	
	3. I use to talk to other people via text, voice call or video call.	Teo et al.(1999) and Chen et al.(2014)
	4. I use the line to send photos and videos to someone else.	
	5. I use the sticker in the Line to represent my words or feelings when I talk to other people.	

DATA ANALYSIS RESULTS

Most respondents are female (62.1%) with the age higher than 40 years old (36.8%), have bachelor degree of education (71.4%), are working in private sectors (35.4%). Respondents use Line with the Android (40.7%) a little bit higher than those with the iOS (33.7%). They usually use Line to communicate miscellaneous matters (39%) followed by to communicate in work context (31.4%). The two Line applications, which are widely used, are sending message (27.44%) and sending stickers (26.12%).

Measurement Model Evaluation

We delete only one item (CNU1) whose outer loadings is less than 0.7 when we conduct the first iteration of evaluation. For the final iteration, we found that all items used to measure each construct are proper for each construct. The composite reliability (CR), Cronbach's alpha and AVE from both iterations of the evaluation imply that our measurement tool is valid for this study. The discriminant validity test is explored by considering the square root of AVE ($\sqrt{\text{AVE}}$) for each construct and the correlation to other constructs in the model. If $\sqrt{\text{AVE}}$ is greater than the correlation between that construct and other constructs in the model raised to the power of 2, we conclude that our constructs have discriminant validity.

Structure Model Evaluation

Structure model evaluation consists of the determination coefficient of three construct. The first construct is satisfaction with coefficient of 0.511 indicating medium level of prediction accuracy. It means that perceived usefulness can explain 51.1 % of the variance of satisfaction. The second one is usage habit with coefficient of 0.654 indicating medium level of prediction accuracy. It means that perceived usefulness, familiarity, perceived monetary value and satisfaction all together can explain 65.4 % of the variance of usage habits. The last one is continuance usage with coefficient of 0.353. It means that usage habits and satisfaction all together can explain 35.3 % of the variance of continuance usage.

Conducting hypotheses tests, we conclude that our data support hypotheses 1, 4, 5 and 7 at the significant of 0.05 but do not support hypotheses 2, 3, and 6 at the significant level of 0.05. Results from hypotheses tests show that Line usage habits are directly derived from perceived monetary value and satisfaction with the path coefficient of 0.232 and 0.567, respectively. Line usage habits is only factor directly and positively impact Line continuance usage with the path coefficient of 0.512. Factors that directly and positively influence Line usage habits are perceived monetary value and satisfaction whereas the indirect and positive influencer is perceived usefulness having satisfaction as a mediator. The indirect effect from perceived usefulness is higher than the direct effect from perceived monetary value. Familiarity and perceived monetary value do not effect Line usage habits. Factor which directly and positively effects Line continuance usage is Line usage habits followed by indirect effect from satisfaction having Line usage habit as a mediator. Finally, satisfaction does not affect Line continuance usage.

DISCUSSION AND RESULTS

This study is concerned about the popularity and the rapid growth of using Line to send messages and other Line applications. We gain the insight that usage habits of people, in the country with rapid growth of using Line, are directly derived from satisfaction is using Line and perceived monetary value. Perceived usefulness indirectly influences Line usage habits by first passing the influence to the satisfaction and then to the Line usage habits. Thus, when people want to generate Line usage habits, they should focus on three main constructs, namely, satisfaction, perceived usefulness and perceived monetary value, respectively. Line usage habits directly impact continuance usage of Line whereas the satisfaction indirectly impact continuance usage of Line by first passing the impact to Line usage habits and then to the continuance usage of Line. In sum, to promote continuance usage of Line, we should mainly concentrate on Line usage habits.

This study combines the expectation-confirmation theory and the habit formation in order to gain the more vivid insights of post-acceptance model of IS continuance in Line usage employed by people in the country which has rapid growth of Line use. The applications of the expectation-confirmation theory and the post-acceptance model of IS continuance focus only continuity not the habits. Our result shows that Line usage habits lead to Line continuance usage and satisfaction also leads to Line continuance usage.

Most of Line services are free, however, the insights pertaining to the habits of using Line and the continuance usage help application developers enlarge their market share and facilitate the introduction of charged services. For example, Line introduces LineMan to serve people as a messenger to deliver favorite foods or meals within the promised time. People love this service because they do not have to queue up for a long time to get their favorite foods or meals. Moreover, our results help Line developers know how to make their customers get used to Line usage or form Line habits. Conversely, they should further investigate the specific functions of Line that satisfied their customers. Since habit is the unconscious or automatic behavior, developers might offer services that fit or conform to their customers' habits and makes them purchase the services unconsciously.

REFERENCES

- Ajjan, H., Hartshorne, R., Cao, Y., & Rodriguez, M.)2014(. Continuance use intention of enterprise instant messaging: a knowledge management perspective. *Behaviour & Information Technology*, 33)7(, 678-692.
- Aarts, H., Paulussen, T., & Schaalma, H.)1997(. Physical exercise habit: on the conceptualization and formation of habitual health behaviours. *Health Education Research*, 12)3(, 363-374.
- Bhattacharjee, A.)2001(. Understanding Information Systems Continuance: An Expectation-Confirmation Model. *MIS Quarterly*, 25)3(, 351-370.
- Bolton, R. and Lemon, K.)1999(. A Dynamic Model of Customers' Usage of Services: Usage as an Antecedent and Consequence of Satisfaction. *Journal of Marketing Research*, 36)2(, 171-186.
- Chen, C., Lai, H., and Ho, C.)2014(. Why do teachers continue to use teaching blogs? The roles of perceived voluntariness and habit. *Computers & Education*, 82, 236-249.
- Chiu, C., Hsu, M., Lai, H., & Chang C.)2012(. Re-examining the influence of trust on online repeat purchase intention: The moderating role of habit and its antecedents. *Decision Support Systems*, 53)4(, 835-845.
- Davis, F. (1989). Perceived Usefulness, Perceived Ease of Use, and User Acceptance of Information Technology. *MIS Quarterly*, 13(3), 319-340.
- Dodds, W., Monroe, K., & Grewal, D. (1991). Effects of Price, Brand, and Store Information on Buyers' Product Evaluations. *Journal of Marketing Research*, 28(3), 307-319.
- Gefen, D. (2000). E-commerce: the role of familiarity and trust. *The International Journal of Management Science*, 28(6), 725-737.
- Gefen, D., Karahanna, E., & Straub, D. (2003). TRUST AND TAM IN ONLINE SHOPPING: AN INTEGRATED MODEL. *MIS Quarterly*, 27(1), 51-90.
- Ha, Y., Kim, J., Libaque-Saenz, C., Chang, Y., & Park, M. (2014). Use and gratifications of mobile SNSs: Facebook and KakaoTalk in Korea. *Telematics and Informatics*, 32(3), 425-438.

- Hong, S. and Tam, K. (2006). Understanding the Adoption of Multipurpose Information Appliances: The Case of Mobile Data Services. *Information Systems Research*, 17(2), 162-179.
- Hong, S., Thong, J., & Tam, K. (2008). Understanding continued information technology usage behavior: A comparison of three models in the context of mobile internet. *Decision Support Systems*, 42(3), 1819-1834.
- Hsiao, C., Chang, J., & Tang, K. (2015). Exploring the influential factors in continuance usage of mobile social Apps: Satisfaction, habit, and customer value perspectives. *Telematics and Informatics*, 33(2), 342-355.
- Hsu, M., Chang, C., & Chuang, L. (2014). Understanding the determinants of online repeat purchase intention and moderating role of habit: The case of online group-buying in Taiwan. *International Journal of Information Management*, 35(1), 45-56.
- Kim, B.)2011(. The diffusion of mobile data services and applications: Exploring the role of habit and its antecedents. *Telecommunications Policy*, 36)1(, 69-81.
- Kim, S., Malhotra, N., & Narasimhan, S.)2005(. Two Competing Perspectives on Automatic Use: A Theoretical and Empirical Comparison. *Information System Research*, 16)4(, 418-432.
- Komiak, S. and Benbasat, I.)2006(. The Effects of Personalization and Familiarity on Trust and Adoption of Recommendation Agents. *MIS Quarterly*, 30)4(, 941-960.
- Kranz, J.)2012(. The Difference Of Determinants Of Mobile Data Services' Adoption And Continuance—A Longitudinal Study. *Thirty Third International Conference on Information Systems*.
- Lam, S., Shankar, V., Erramilli, M., & Erramilli, B.)2004(. Customer Value, Satisfaction, Loyalty, and Switching Costs: An Illustration from a Business-to-Business Service Context. *Journal of the Academy of Marketing Science*, 32)3(, 293-311.
- Limayem, M. and Cheung, C.)2008(. Understanding information systems continuance: The case of Internet-based learning technologies. *Information & Management*, 45)4(, 227-232.
- Limayem, M. and Hirt, S.)2003(. Force of Habit and Information Systems Usage: Theory and Initial Validation. *Journal of the Association for Information Systems*, 4, 65-97.
- Limayem, M., Hirt, S., & Cheung, C.)2003(. Habit in the Context of IS Continuance: Theory Extension and Scale Development. *European Conference on Information Systems*, Paper 90.
- Limayem, M., Hirt, S., & Cheung, C.)2007(. How Habit Limits the Predictive Power of Intention: The Case of Information Systems Continuance. *MIS Quarterly*, 31)4(, 705-737.
- Morrison, D. and Firmstone, J.)2000(. The social function of trust and implications for e-commerce. *International Journal of Advertising*, 19, 599-623.
- Oliver, R.)1993(. Cognitive, Affective, and Attribute Bases of the Satisfaction Response. *Journal of Consumer Research*, 20)3(, 418-430.
- Oghuma, A., Libaque-Saenz, C., Wong, S., & Chang, Y.)2015(. An expectation-confirmation model of continuance intention to use mobile instant messaging. *Telematics and Informatics*, 33)1(, 34-47.
- Orbell, S., Blair, C., Sherlock, K., & Conner, M.)2001(. The Theory of Planned Behavior and Ecstasy Use: Roles for Habit and Perceived Control Over Taking Versus Obtaining Substances. *Journal of Applied Social Psychology*, 31)1(, 31-47.

- Ouellette, J. and Wood, W.)1998(. Habit and Intention in Everyday Life: The Multiple Processes by Which Past Behavior Predicts Future Behavior. *Psychological Bulletin*, 124)1(, 54-74.
- Pura, M.)2005(. Linking perceived value and loyalty in location-based mobile services. *Managing Service Quality: An International Journal*, 15)6(, 509-538.
- Teo, T., Lim, V., & Lai, R.)1999(. Intrinsic and extrinsic motivation in Internet usage. *The International Journal of Management Science*, 27)1(, 25-37.
- Thong, J., Hong, S., & Tam, K.)2006(. The effects of post-adoption beliefs on the expectation-confirmation model for information technology continuance. *International Journal of Human-Computer Studies*, 64)9(, 799-810.
- Thong, S., Thong, J., Moon, J., & Tam, K. (2008). Understanding the behavior of mobile data services consumers. *Information Systems Frontiers*, 10(4), 431-445.
- Verplanken, B., Aarts, H., & Knippenberg, A.)1997(. Habit, information acquisition, and the process of making travelmode choices. *European Journal of Social Psychology*, 27, 539-560.
- Wood, W., Quinn, J., & Kashy, D.)2002(. Habits in Everyday Life: Thought, Emotion, and Action. *Journal of Personality and Social Psychology*, 83)6(, 1281-1297.
- Zhou, T. and Lu, Y.)2011(. Examining mobile instant messaging user loyalty from the perspectives of network externalities and flow experience. *Computers in Human Behavior*, 27)2(, 883–889.

KNOWLEDGE, ATTITUDES, AND BELIEFS OF SOUTH AFRICAN ANTIRETROVIRAL CARE RECEIVERS ON HIV AND AIDS

Caroline Satche and Emeka E Obioha
Walter Sisulu University, South Africa

ABSTRACT

UNAIDS alluded that the perception around disease and ill health has been identified as an important factor influencing health-seeking behaviour. In this regard community knowledge and beliefs about disease and health do significantly impact on health-seeking behaviour of its members and treatment outcomes. Against the above, this study therefore assessed the knowledge, beliefs and attitudes of HIV patients to determine whether they have the right kind of attitude towards HIV/AIDS. While the "Health belief model" was utilised to explain and predict the subjects' health-related behaviour, this study made use of a sample of 112 purposively chosen patients attending Infectious Disease Clinic at Mthatha, South Africa. A close ended survey instrument (Questionnaire) was used to collect the data, while relevant Statistical Package for the Social Sciences (SPSS) techniques were used to analyse the field data. The results from the study showed that the majority of respondents were aware of the existence of HIV/AIDS and how it is transmitted; that having sex without a condom or sharing sharp objects with an infected person can lead to HIV transmission; while kissing an HIV-infected person cannot cause the disease. The majority of respondents have positive attitudes towards those who are infected with HIV/AIDS as they agreed that the disease cannot be transmitted by sharing and eating with utensils that have been used by an HIV+ person or by associating with friends and family of HIV+ persons. Most respondents were optimistic that HIV/AIDS is not a death sentence, unfortunately, a majority also believe that using condoms when already infected with HIV is not necessary and because there is no cure for HIV, taking HIV drugs is a waste of time. This study recommended more public target education on areas where the respondents are ignorant or not having the positive attitude.

Keywords: Beliefs, Knowledge, Attitudes, Patients, HIV/AIDS, South Africa.

INTRODUCTION

The Human Immunodeficiency Virus/Acquired Immune Deficiency Syndrome (HIV/AIDS) epidemic has become one of the most important public health problems in recent times. In South Africa nowadays, individuals, families, and communities are seriously affected by HIV/AIDS. According to household surveys conducted by the human sciences research council in 2000 (Whiteside & Sunter 2000). People living in rural and urban informal settlements seemed to be at higher risk. It is estimated that more than 1700 people are newly infected every day and that a total of 4.2 million South Africans are infected, placing South Africa, first in the world in the number of infected individuals (UNAIDS 2000). Research that has been conducted by various researchers shows that the higher rates of infection are prevalent at the ages from fifteen to twenty-four because the victims are at the reproductive stage. Every day, 6,000 young people become infected with HIV more than five every minute. Alone in the United States, half of all new infections are estimated to be among people under age 25 years and the majority of young people are infected sexually. This appears to be stabilization in HIV prevalence rates, but this is mainly due to a rise in AIDS deaths and a continued increase in new infections. Prevalence is still rising in some countries such as Madagascar and Swaziland and is declining nationwide in Uganda (UNAIDS 2004).

In most part of the world, the rate of HIV infection is exacerbated by the lack of information on this deadly virus while the attitudes, the knowledge and the beliefs of people act as barriers to a comprehensive response to

HIV/AIDS. Knowledge about HIV/AIDS has been identified as a powerful tool to prevent the transmission of the disease but despite the fact that a large percentage of the south African population had accurate knowledge about the aspects of HIV epidemic, unfortunately, this knowledge about the disease has not resulted in appreciable changes in attitude or in behavior change in the population. For example, the study conducted by the University of Johannesburg, in South Africa, reported that most students had knowledge about HIV/AIDS and its transmission but although these students were knowledgeable about HIV/AIDS, many did not change their behavior as a result of their knowledge. Therefore, it is essential to assess the knowledge, attitudes, and beliefs of HIV patients regarding HIV and AIDS in relation to treatment outcomes before planning appropriate preventive measures. Community knowledge and beliefs about disease and health have a significant impact on health-seeking behavior and treatment outcomes. The perception around disease and ill health has been identified as an important factor influencing health-seeking behavior. (UNAIDS 2000). The former national minister of education, Kader Asmal has stated: "we must deal urgently and purposefully with the HIV/AIDS emergency in and through the education and training system" (Joint United Nations Program on HIV/AIDS 2012). Later in the same year, professor Alma also stated; "the ministry is committed to minimizing the social, economic and developmental consequences of HIV/AIDS in the educational system and to provide leadership to implement an HIV/AIDS policy". It is important that not only cognitive information concerning HIV/AIDS is provided to those entrusted with the task of helping to prevent the spread of HIV/AIDS, but also concerning the factors that influence their attitudes and beliefs. An investigation is therefore essential in assessing the knowledge, beliefs of HIV patients to determine whether the patients have the right kind of attitude towards HIV/AIDS. If they do not have the right kind of attitude, there will be consequences because HIV/AIDS affects stigma; it affects family life since many children are left orphans in South Africa; HIV/AIDS affects income and it also affects education, for example, those families living with someone suffering from HIV/AIDS are less likely to be able to attend school as they are caring for their sick parents. (Joint United Nations Program on HIV/AIDS 2013). The main aim of this study was to find out about the knowledge, attitudes, and beliefs of Patients on HIV and AIDS. The questions are: What is the extent of knowledge of HIV/AIDS amongst the patients towards HIV/AIDS? What kinds of attitudes do the HIV/AIDS patients have towards HIV? What are the dominant beliefs of HIV patients on HIV/AIDS?

THEORETICAL ORIENTATION

Health Belief Model

"Health belief model attempts to explain and predict health-related behavior from certain belief patterns" (Ajzen 1991). "Health Belief Model addresses the individual perceptions of the threat passed by a health problem (susceptibility and severity), the benefits of the avoiding the threat and factors influencing the decision to act (barriers, cues to action and self-efficacy)" (Randall et al. 2009). Randall et al (2009) 'distinguish perceived susceptibility, perceived seriousness or severity, perceived threat, perceived benefits and perceived barriers (self-efficacy and cues to action) as the one that guided a person to change the behavior.' In Perceived threats, Health Belief Model gives emphasis to the need for people to balance fear with a sense of self-efficacy if action is to occur. For behavior change to succeed people must feel threatened by their current behavior patterns and the threat from it must be recognized as important. With Perceived Susceptibility, the model postulates the readiness to take action for health stems from an individual's perception of their susceptibility to diseases, its potential severity and the availability of an effective method for an averting disease. The person must believe that his or her health is in jeopardy. For an asymptomatic disease such as HIV, the person must believe that he or she can have it and not feel symptoms. On Perceived Seriousness or Severity, the person must perceive the potential seriousness of the condition in terms of pain or discomfort, time lost from work and economic difficulties. In Perceived Benefits, the person must believe that change of a specific kind will result in a valued outcome at an acceptable cost. On assessing the circumstances, the person must believe that benefit stemming from the recommended behavior outweigh the cost and convenience, and are indeed possible and within his or her grasp. And in Perceived Barriers, we have self-efficacy and cues to action. The Self-efficacy is the competency to perform the behavior needed to influence the outcomes. The person must feel his or her self-competent overcome perceived barriers to taking action. And in Cues to action, there must be a precipitating force that makes the person feels the need to take action. Cues to action are about how events are linked and what leads to what and how behavior is likely to influence outcomes.

METHODOLOGY

The population consisted of patients attending Infectious Disease Clinic at Gateway Clinic (Mthatha). For the purpose of this investigation, the target populations were patients attending infectious disease clinic, they were chosen for the study. In selecting the sample, the researcher used purposive sampling in the sense that she targeted only HIV/AIDS patients amongst other infectious diseases patients. However the selection of participants was purely randomly done. The clinic was also selected because of their accessibility. The sample size was 112 HIV adults' patients. The researcher selected the subjects on the basis of the knowledge of the population. A judgment was made about which subject should be selected to provide the best information for addressing the purpose of the research, hence the selection of patients attending Infectious Disease Clinic and the patients were taken as they arrived. In this study, the researcher made use of the survey. Survey research is a non-experimental design used when a researcher wants to know what people are thinking, feelings, doing and believing. The present researcher used a survey in order to find out the extent of the knowledge of HIV patients and their attitudes and beliefs towards HIV/AIDS. The survey instrument used in this research was a questionnaire, which was administered to participants by the researcher for systematizing data collection. In analysing the data, the researcher used the quantitative data analysis procedure for analysing responses to the questionnaire. This study asked questions to which people had the answer either Yes or No, etc. Questions of this type required nominal data. That is why the study analysed data using percentages and tables of percentages to compare different groups of responses. That means the data were analyzed by means of statistical procedures (the SPSS computer program) to calculate and interpret the frequency and percentage of responses.

RESULTS AND FINDINGS

General Knowledge of HIV patients attending Infectious Disease Clinic about HIV/AIDS

General knowledge is a very important aspect of the human life; it is openness to experience and knowledge about different things. General knowledge gives you a great knowledge of everything going around you and helps you in making some wise decisions. General knowledge of HIV patients is the knowledge they have about HIV/AIDS. With regard to awareness of the existence of HIV/AIDS, 87.5% of the sample's subjects were aware of the existence of HIV/AIDS, a number 4.5% claimed to be unaware of the existence of HIV/AIDS while 8% of the sample population are not sure whether HIV/AIDS exists or do not exist. This indication shows that the majority of the sample population was aware of the existence of HIV/AIDS. On how HIV is transmitted, it can be seen in Table 1 that 91.1% of the sample population has the knowledge about the mode of transmission of HIV/AIDS, while 6.2% of the population is not sure and 2.7% of the population is not aware of the mode of transmission of HIV/AIDS. This is an indication that the majority of the respondents know how HIV is transmitted, meaning that the HIV/AIDS programs on radio, TV, posters, and HIV programs in the clinics do reach people. For the fact that HIV is a disease without a cure, it has been demonstrated that 58.9% of the respondents are aware that HIV/AIDS is a disease without a cure, whereas 25% of the population claimed not to be aware that HIV/AIDS is a disease without a cure, and 16.1% of the population are not sure whether HIV/AIDS does have a cure or not. The fact that only 58.9% are aware that HIV/AIDS is a disease without a cure indicated that were many who were not still well informed about HIV/AIDS; something needs to be done in a form of educating people that HIV/AIDS is not curable.

With regard that unprotected sex can lead to HIV infection, it can be deduced that the majority of the respondents 95.5% of the sample population are aware that sex with an infected partner without a condom can lead to HIV infection, 2.7% of the sample population are not aware that sex with an infected partner without a condom can lead to HIV, whereas 1.8% of the population are not sure whether sex with an infected partner can lead to HIV infection. This is an indication that the majority of the respondents are well aware that having sex without a condom is a risky activity. For the fact that sharing instruments can spread HIV, 83% of the sample population are aware that sharing any skin piercing instruments that cause bleeding can spread HIV and AIDS, while 10.7% of the sample subjects are not aware that sharing instruments that cause bleed can spread HIV and AIDS. And 6.2% are not sure

whether sharing instruments that cause bleed can spread HIV/AIDS. This showed that the majority of the respondents have knowledge about the mode of transmission of HIV/AIDS but the fact that 10.7% of the sample population are not aware that sharing piercing instrument can cause HIV, and that 6.2% of the respondents are not yet sure demonstrated that there is still a need for education. On how sexually transmitted diseases increase HIV transmission, about 86.6% of the respondents agreed with the statement, which showed that respondents knew that sexually transmitted disease increase the probability of HIV transmission, while 11.6% of the respondents are not sure whether sexually transmitted disease can increase the probability of HIV transmission or not and 1.8% disagreed with the fact that sexually transmitted disease can increase the probability of HIV transmission. This is an indication that the majority of respondents were aware that STD is more dangerous for an HIV+ person. On how to tell by someone's appearance if he/she is HIV+, it can be deduced that 72.3% of the respondents disagreed with the fact that it cannot be told by someone's appearance that he/she is HIV+, while 22.3% of the respondents agreed that it can be told by someone's appearance that he/she is HIV+ and 5.4% of the respondents are not sure whether it can be told or not by someone appearance if he/she is HIV+. This showed that the majority of respondents are aware that HIV cannot be read in someone appearance, and at the same time this is also an indication that some people still need to be educated that when an HIV+ person takes his/her ARV properly and regularly, it cannot be told by his/her appearance that he/she is infected with the disease. To the fact that HIV can be transmitted from mother to child, it can be deduced that 69.6% of the sample population are aware that HIV can be transmitted from mother to child during childbirth if the mother is HIV+, while 19.6% of the respondents are not aware that HIV can be transmitted from mother during childbirth and 10.7% of the respondents are not sure whether HIV can be transmitted or not from mother during childbirth. This indicated that the some of the respondents are aware that HIV can be transmitted from mother to child during birth while some still lack knowledge, so there is a need for education. With regard that HIV+ person is not the same as a person who has AIDS; we can see that 78.4% of the sample populations are aware that being HIV+ does not necessarily mean that a person has AIDS. While 15.3% of the sample populations are not aware that being HIV+ does not necessarily mean that a person has AIDS and 6.3% of the sample population are not sure whether being HIV+ does not necessarily mean that a person has AIDS. This is an indication that the majority of the population is aware that HIV is not the same as having AIDS.

Table 1: Responses on general knowledge of HIV/AIDS among the respondents

Item	Response		
	No	Not sure	Yes
Awareness of HIV/AIDS	5(4.5%)	9(8.0%)	98(87%)
How HIV is transmitted	3(2.7%)	7(6.2%)	102(91.1%)
HIV is a disease with no cure	28(25.0%)	18(16.1%)	66(58.9%)
Unprotected sex lead to HIV	3(2.7%)	2(1.8%)	107(95.5%)
sharing piercing instruments cause HIV	12(10.7%)	7(6.2%)	93(83.0%)
STDs increase HIV	2(1.8%)	13(11.6%)	97(86.6%)
Recognize HIV+ person by appearance	81(72.3%)	6(5.4%)	25(22.3%)
Transmission of HIV from mother to child	22(19.6%)	12(10.7%)	78(69.6%)
HIV+ is not AIDS	17(15.3%)	7(6.3%)	87(78.4%)
Taking HIV drugs is a waste of time	87(77.7%)	5(4.5%)	20(17.9%)
.	All of the above	Some of the above	None of the above
HIV caused by poverty, mosquitoes, etc	4(3.6%)	51(45.5%)	57(50.9%)

Similarly, about the notion that taking HIV drugs is a waste of time, it can be seen that 77.7% of the sample population are aware that despite the fact that there is no cure for HIV, taking the drugs is not a waste of time. Whereas 17.9% of the respondents think that because there is no cure for HIV, taking the drugs is a waste of time. And 4.5% of the sample population are not sure whether taking the drugs of HIV since there is no cure, is a waste of time or not. This is an indication that some of the respondents are aware that it is not a waste of time for an HIV+ person to take his/her drugs while some still don't know the value of taking their medication; and this showed that some have limited information and that they should be more exposed to the information. On how HIV is caused, it can be said that 50.9% of the respondents think that HIV is not caused by poverty, a virus, cold weather, by being bewitched and mosquitoes. Followed by 45.5% of the respondents who think that HIV can be caused by some of

these factors while 3.6% think that HIV is caused by poverty, a virus, cold weather, by being bewitched and mosquitoes. This is an indication that some of the respondents are aware that HIV is not caused by poverty, a virus, cold weather, by being bewitched and mosquitoes, while some still need to be educated.

Attitudes of HIV patients towards HIV/AIDS

Attitude is a way you feel about something or someone. It influences an individual's choice of action and responses to challenges. The attitudes of HIV patients here implies the way they feel and behave about other HIV people. Responses on the attitudes of the patients towards HIV/AIDS are presented in Table 2. With regard of kissing an HIV+ person, we can say that respondents had different views concerning kissing infected people. Some of them maintained that there was nothing wrong with kissing a person infected with HIV/AIDS and they were 73.9%, whilst the others were very skeptical about doing so and they were 14.4%. Moreover, there were those who were not sure about kissing a person suffering from the disease and they were 11.7% of the total population. This is an indication that the majority of respondents did not have a discriminatory attitude towards HIV infected person and this result may have an implication on the fast spread of HIV in Eastern Cape and if kissing is passionate, then it is dangerous. With regard to HIV+ persons of using same eating and bathing facilities with HIV-negatives ones, it can be deduced that the largest number 75.9% of respondents feel that it is proper for people who are infected with HIV/AIDS to use the same eating and bathing facilities with people who are not infected, that HIV/AIDS positive people could not infect the non-infected ones with the disease. Some (15.2%) felt that using the same eating and bathing facilities with people who are not infected can spread the disease. And there were also 8.9 % who were not sure whether it is proper or not for people who are infected with HIV/AIDS to use the same eating and bathing facilities with people who are not infected. This is an indication that the majority of respondents are aware that HIV cannot be transmitted by using the same eating and bathing facilities with those who are infected. On how people react when they find out that their friends are HIV+, it can be deduced that 86.6% of the total population disagreed that they won't react negatively if they find that their friends are HIV/AIDS positive, while 9.8% of the total population agreed that they will react negatively if they find that their friends are HIV/AIDS positive and 3.6% of the total population are not sure whether they will react positively or negatively to their friends if they find that they are HIV/AIDS positive. This is an indication that the majority of respondents would not have a negative attitude towards their friends who are HIV/AIDS positive.

Considering shaking hands and drinking tea in the same cup used by an HIV/AIDS infected person, we can say that the largest number of the respondents 85.7% agreed that they can shake hands, and drink tea in the same cup used by a person infected with HIV/AIDS . While 8.9% of the respondents disagreed that they cannot shake hands and drink tea in the same cup used by an HIV/AIDS infected person. And 5.4% of the respondents are not sure whether they will react positively or negatively towards shaking hands and drinking tea in the same cup, used by an HIV/AIDS infected person. This is an indication that people are aware that shaking hands and drinking tea with an infected person cannot cause the disease to those who are HIV negative. With regards to association with family or friends of HIV/AIDS patients, it can be deduced that 92% of the sample population can associate with family or friends of HIV/AIDS patients, while 4.5% of the sample population cannot associate themselves with family or friends of HIV/AIDS patients and 3.6% of the sample population are not sure whether they can associate themselves with family or friends of HIV/AIDS patients. This is an indication that the majority of respondents are well aware that association with HIV/AIDS friends and their family cannot cause the disease. On how receiving the treatment can be shameful or not, it can be deduced that the largest number of the respondents 90.2% don't feel that receiving the treatment is shameful. Whereas 6.2% of the respondents feel that receiving the HIV treatment is shameful and 3.6% of the respondents are not sure whether receiving the HIV treatment is shameful or not shameful. This is an indication that the majority of the total population has a positive attitude when they are receiving their treatment, they don't find any shame in doing so.

The study indicated that 70.5% of the total population don't feel that taking medication for the rest of their life is boring, whereas 25% of the total population feel that taking medication for the rest of their life is boring and 4.5% of the total population are not sure whether taking medication for the rest of their life is boring or not. The result showed that some of the sample population doesn't feel boring to take their medication for the rest of their lives, while some feel boring to take their medication for the rest of their lives. This is an indication that there is a

need to strengthen the awareness program in relation to HIV/AIDS, so that those who feel boring to take their medication for the rest of their lives should understand the importance of taking their medication for the rest of their lives; and in the same time, they need encouragement from nurses, families members and friends who know about their status.

With regards to using condoms when you are already infected with HIV is not necessary, it can be deduced that 54.5% of the respondents think that practicing preventive measures like using condoms when you are already infected with HIV is not necessary, whereas 42% of the respondents think that it is necessary to use condoms even if you are already infected with HIV and 3.6% of the respondents are not sure whether using condoms or not when you are already infected with HIV is necessary or no necessary. This is an indication that the majority of the total population thinks that using condoms when you are already infected with HIV is not necessary, which is very wrong and this result points on how HIV+ persons are infecting others who are HIV negative. And by having a negative attitude on transmitting the disease to those who are not infected with the disease, they might reinfect themselves even more. This is an indication of an urgent and serious need of education to HIV+ persons to protect those who are not infected with HIV and at the same time to protect themselves for reinfection which can shorten their lives.

Table 2: Responses on attitudes of HIV patients towards HIV/AIDS

Item	Response		
	No	Not sure	Yes
Kissing an HIV+ person	16(14.4%)	13(11.7%)	82(73.9%)
Using same bathing facility with HIV+	17(15.2%)	10(8.9%)	85(75.9%)
Negative reaction towards HIV friends	97(86.6%)	4(3.6%)	11(9.8%)
Shaking hands with HIV+ person	10(8.9%)	6(5.4%)	96(85.7%)
Association with HIV friends/family	4(3.6%)	5(4.5%)	103(92.0%)
Receiving treatment is shameful	101(90.2%)	4(3.6%)	7(6.2%)
Taking medication forever is boring	79(70.5%)	5(4.5%)	28(25.0%)
Using condoms when HIV+ is not necessary	47(42.0%)	4(3.6%)	61(54.5%)

Beliefs of HIV patients on HIV/AIDS

Belief means trust, faith, or confidence (in someone or something). It is also a feeling of being sure that someone or something exists or that something is true. The beliefs of HIV patients on HIV/AIDS are their feelings of being sure that something really exists with regard to HIV/AIDS. The result of the respondents' beliefs is presented in Table 3. With regard that HIV treatment can prolong the life of an individual, it can be deduced that 80.4% of the total population believed that HIV/AIDS treatment can prolong the life of an individual. Whereas 9.8% didn't believe that HIV/AIDS treatment can prolong the life of an individual and 9.8% were not sure whether HIV/AIDS treatment can prolong the life of an individual or not. This indicated that the majority of respondents believed that ARVs can prolong the life of an individual. For the belief that traditional healer can heal HIV/AIDS, it can be deduced that 84.8% of the respondents did not believe that traditional healer can heal HIV/AIDS, while 7.1% of the respondents believed that traditional healer can heal HIV/AIDS and 8% were not sure whether traditional healer can heal HIV/AIDS or not. This is an indication that the majority of the total population knows that traditional healer cannot heal HIV/AIDS because we have never heard before or even now that there is a traditional healer who has healed someone from HIV/AIDS. On how prayer can heal someone from HIV/AIDS, we can say that the majority of respondents 66.1% did not believe that prayer can heal someone from HIV/AIDS, while 18.8% of respondents believed that prayer can heal someone from HIV/AIDS and 15.2% of the respondents were not sure whether prayer can heal someone from HIV/AIDS or not. This indicated that the majority of the respondents did not believe that prayer can heal an HIV/AIDS person, while some believed that an HIV/AIDS person can be healed with prayer. And for those who did not believe in prayer, maybe they have never seen someone before who was healed from prayer; and for those who believed in prayer, maybe they have faith in God or because they have seen someone healing from prayer before.

With regards that having HIV/AIDS is a death sentence, it can be deduced that 88.4% of the total population do not believe that having HIV/AIDS is a death sentence, whereas 8% of the total population believe that having HIV/AIDS is a death sentence and 3.6% of the total population are not sure whether having HIV/AIDS is a death sentence or not. This is an indication that the majority of the total population is aware that having HIV/AIDS is not a death sentence. This further indicates a change in the belief from what it used to be in the past. With the perception of the vulnerability of HIV infection, it can be deduced that the largest respondents 65.2% perceived that the vulnerability of HIV infection is high, while 24.1% of the respondents perceived that the vulnerability of HIV infection is medium and 10.7% of the respondents perceived that the vulnerability of HIV infection is low. This showed that the majority of the respondents knew that the vulnerability of HIV infection is high. But with the 24.1% and 10.7% of the respondents who do not believe that the vulnerability of HIV infection is high, we can deduce that some still lack knowledge and that something needs to be done in a form of educating people about the danger of the pandemic.

For the belief that HIV contraction can have serious consequence on someone's health, it can be deduced that 65.2% of the sample population believed that HIV contraction can have serious consequences on someone's health. While 24.1% of the sample population did not believe that HIV contraction can have serious consequences on someone's health and 10.7% of the sample population were not sure whether HIV contraction can have serious consequences on someone's health or not. This indicated that some of respondents were aware that when a person contract HIV, it can have a serious consequences on that person's health, while some still don't believe that HIV contraction can have serious consequences on someone's health, and this meant that there are some who were still not well informed about HIV/AIDS; meaning the impact of the awareness programs were limited and that programs needed to be improved. On how practicing preventive actions can reduce HIV transmission, it can be deduced that 71.4% of the respondents believed that practicing preventive actions can effectively reduce the vulnerability of HIV transmission or reduce its seriousness when already contracted. While 14.3% of the respondents did not believe that practicing preventive actions can effectively reduce the vulnerability of HIV transmission or reduce its seriousness when already contracted and 14.3% of the respondents were not sure whether practicing preventive actions can effectively reduce the vulnerability of HIV transmission or reduce its seriousness when already contracted. This showed that the majority of the respondents were aware that practicing preventive actions can reduce HIV transmission or reduce its severity when already contracted.

Table 3: Responses on beliefs of HIV patients on HIV/AIDS

Item	Response		
	No	Not sure	Yes
ARVs can prolong life	11(9.8%)	11(9.8%)	90(80.4%)
Traditional healer heals HIV/AIDS	95(84.8%)	9(8.0%)	8(7.1%)
Prayer heals HIV	74(66.1%)	17(15.2%)	21(18.8%)
Having HIV is a death sentence	99(88.4%)	4(3.6%)	9(8.0%)
HIV have consequences on health	27(24.1%)	12(10.7%)	73(65.2%)
Preventive actions can reduce HIV transmission	16(14.3%)	16(14.3%)	80(71.4%)
Perception of vulnerability of HIV	High 73(65.2%)	Medium 27(24.1%)	Low 12(10.7%)

DISCUSSIONS

The present study evaluated the knowledge, attitudes, and beliefs of HIV/AIDS patients towards HIV/AIDS and the treatment outcomes in Mthatha, Eastern Cape and the study revealed that the majority of respondents were aware of the existence of HIV/AIDS, and knew about the mode of transmission of the disease. The attitudes and beliefs of the majority of respondents were found to be accepting and positive towards people living with HIV/AIDS. The social media like Television, radio, internet, posters and also the HIV programs in the clinics were the most common means of obtaining information about HIV/AIDS. Studies in Southeast Asia have shown that most media have done little to change existing cultural values and prejudice about the sexuality and the situation of people who are living

with HIV or AIDS. They were good at educating people that HIV and AIDS exist but mainly in a frightening way because they have seldom given enough in-depth information to contextualize this information. Taking everything into account, media should apply new methods of AIDS education to improve public knowledge about HIV/AIDS. The study demonstrated that the majority of respondents had knowledge on HIV/AIDS, including positive attitudes and beliefs towards HIV persons but the study also revealed some lack of knowledge among respondents. Female respondents demonstrated a slightly higher level of knowledge in comparison with male respondents in most items pertaining to HIV/AIDS; this difference is small and practically insignificant but consistent with the studies of Kulwicki. However, Xinming (2003) found that boys had better knowledge than girls and their explanation for this finding was that boys feel freer than girls to talk about matters relating to sex and HIV/AIDS. Overall, it has been also been noticed in the result that respondents with a lower level of education are those that lack more knowledge than those who are more educated.

CONCLUSION

The data in this study revealed conflicting arguments. There were those who displayed knowledge about HIV/AIDS whilst there were those who still displayed limited knowledge about this pandemic. The good part is that those who displayed knowledge about HIV/AIDS are more than those who still displayed limited knowledge; but although there are some programs on the TV, radio, newspapers, in the community and in the clinics to educate people about this disease, data showed that something else needs to be done so as to curb the pandemic. The most comforting information was that clinics have programs in place on HIV/AIDS. However, the majority of the respondents argued that practicing preventive measures like using condoms when you are already infected with HIV is not necessary. This showed that some of the respondents did not have adequate knowledge on HIV/AIDS and still need to be educated.

REFERENCES

- Ajzen, I. (1991). The theory of planned behavior. *Organizational Behavior and Human Decision Processes*, 50(2), 179-211.
- Human Sciences Research Council (HSRC). (2012). "South African National HIV prevalence, incidence and behavior survey".
- Joint United Nations program on HIV/AIDS (UNAIDS). (2013). Global report: *UNAIDS report on the global AIDS epidemic 2013*. Geneva, Switzerland: UNAIDS.
- Joint United Nations program on HIV/AIDS. (2012). *UNAIDS report on the global AIDS epidemic: Annexes*. Geneva, Switzerland: UNAIDS.
- Kulwicki, A. (1994). An assessment of Arab American knowledge, attitudes and beliefs about AIDS. *Journal of nursing scholarship*, 26, 13-17.
- Randall, R., Cotrell, J., Mackenzie, J., & Giwan. (2009). *Principles and Foundations of Health Promotion and Education*.
- UNAIDS. AIDS epidemic update: December, (2000). Geneva: UNAIDS.
- UNAIDS. Executive Summary: report. (2004). *Report on the Global AIDS Epidemic*.
- Whiteside, A., & Sunter, C. (2000). *AIDS: the challenge for South Africa*. Cape Town: Human & Rousseau, Tafelberg.
- Xinming, W. (2003). Research on knowledge, attitudes and sexual belief among university students in Quanzhou city. *Health education* 19(12), 933.

MANAGEMENT PERSPECTIVES ON A TALENT VALUE PROPOSITION FOR ACADEMIC STAFF IN A SOUTH AFRICAN HIGHER EDUCATION INSTITUTION

Musa Saurombe, Nicolene Barkhuizen and Nico Schutte
North-West University, Mafikeng Campus, South Africa

ABSTRACT

Academic staff members play a pivotal role in the success of higher education institutions (HEIs); therefore, it is imperative to create an employment brand that will attract and retain them. The main objective of this study was to explore the components of an employment brand that should form part of a talent value proposition for academic staff from the perspective of higher education management. A qualitative research approach was adopted, using semi-structured interviews to collect data from the management staff (N=12) of a merged South African HEI. Three components, namely fringe benefits/incentives and remuneration, leadership and managerial support, and occupational health and safety are the most important factors affecting the desirability of the employer brand of the HEI. This research identified the key elements that should form part of a HEI's employment brand in order to develop a talent value proposition that will attract and retain academic staff.

Keywords: Academics, Employment Brand, Higher Education, Talent Value Proposition, Talent Management.

INTRODUCTION

Academic staff members play a pivotal role in the success of higher education institutions (HEIs); therefore, it is imperative to build an employment brand that will appeal to them. An employment brand is the result of a concise, enduring plan to govern the awareness and opinions of employees, prospective employees, and associated stakeholders concerning a specific organisation, such as a HEI (Sullivan, 2004). Employment branding is an organisation's efforts to make it distinguishable and preferable as an employer (Muncherji, Gopalakrishnan, & Dhar, 2009). It is a strategy to establish the employer as a workplace of preference that enhances the recruitment and retention of high-performance staff members, and to manage productivity (Sullivan, 2004). The terms *employment branding* and *employer branding* fundamentally represent the same notion; therefore, the researcher uses the terms synonymously.

The relatively recent term *employer branding* was introduced by Ambler and Barrow (1996), who described it as "the package of functional, economic and psychological benefits provided by employment, and identified with the employing company" (p. 187). The term has accrued significant consideration from academics, marketing executives, human resource (HR) managers, and management consultants (Savignano, 2007). The concept of employment branding in HEIs was first applied in the early 1990s to indicate organisations as employers (Annapoorna, 2015). Existing employment branding literature is mainly restricted to the discerning of potential employees as a target category (Robinson, 2014). This led to the present researcher focusing on the perceptions of current academics concerning the employment brand of the merged South African HEI under study. In the context of the war for talent (e.g., Torress-Coronas, 2008; Sparrow & Cooper, 2011; Martin, Gollan, & Grigg, 2011), a resilient employment brand is considered essential to achieving the status of an employer of choice and enticing high-calibre academics (Sehgal & Malati, 2013).

The surge in rivalry for talent towards the conclusion of the 20th century implied that employers, including HEIs, needed to devise a strategy for distinguishing themselves from their contenders in the struggle to entice and keep talented employees (Parry & Tyson, 2013). As noted by Evans and Chun (2012), one of the main benefits of a HEI having an extensive and well-deliberated talent management strategy is the capacity to transform the organisation's culture and assist in the achievement of diversity — elements that are becoming increasingly important to employees in South Africa's diverse economy. The embracing of marketing strategies by the HR function is directly aligned with the requirement for competitiveness in the labour market, similar to the manner in which the dependence on employees to stimulate organisational values via internal marketing in the 1980s and thereafter was motivated by the necessity for an organisation to contend for customers (Parry & Tyson, 2013).

Srivastava and Bhatnagar (2010), in a study conducted in India, established eight drivers of an employer brand's desirability: being considerate (e.g., the institution caring for its employees), empowerment (e.g., allowing the academic to apply her or his aptitudes), career advancement (e.g., progression and development opportunities and prospects), being trustworthy and impartial (e.g., treating academics fairly), being principled and accommodative (e.g., no corrupt practices), customer brand appearance (e.g., clients' perception of the organisation's brand), affirmative employer image (e.g., how current academics perceive the institution), and international exposure (e.g., prospects of travel).

Because a TVP is a key principle in the war for talent (Sparrow & Cooper, 2011), it has become increasingly essential for organisations to make it a priority in their management policies. Martin, Burke and Cooper (2011) are of the opinion that people management apprehensions are ill-hypothesised in the majority of accounts with regard to corporate reputation and branding, which usually embrace a very unitarist outlook of organisational life. In terms of TVPs, analysts normally evade addressing predicaments related with the need to retain control and pursue commitment from workers, and more skilled and pragmatic methods are required to handle these difficulties at the workplace (Francis, 2006).

A sound TVP is therefore recommendable due to the challenges associated with attracting, magnetising or recruiting as well as retaining talent. Such an initiative would positively reinforce the psychological contract between the institution and its employees, thus resulting in greater commitment, less turnover as well as a higher calibre of potential employees that are attracted. The TVP is a prevailing instrument and exercise that has been used throughout the previous decade to increase the attractiveness of organisations to their employees. A properly assembled and delivered TVP provides an orderly system through which talent, internal brand, engagement, work, leadership, recognition, rewards and behaviours are interweaved together with other components in order to attract, retain and engage employees (Zinger, 2013). Finney (2008) is of the opinion that organisations cannot realistically carry on providing the value proposition that they may have been executing efficaciously over the past decade. This owing to the fact that changes in the industry, competitive environments as well as corporate structures corner numerous companies into experiencing significant variations in the deal that they are able to offer employees. Human capital is the critical element of any prosperous business and in the midst of every grand business plan, and people are present who will incorporate the measures required to guarantee the ultimate success or failure of these plans (Fitz-enz, 2010).

The existing lack of employer branding methods for universities can be explained by the fact that academic labour markets are typically categorised as buyers' markets – in other words the supply of faculty surpasses its demand (Hargens, 2012). For universities, this implies that they do not compete with other universities and with organisations outside academia (Brosi & Welpe, 2014). Additionally, assuming that employer branding is less significant in buyers' markets, Employer Branding improves both the quantity and quality of the applicants' pool including the satisfaction and identification of current employees (Edwards 2010), which are positively related to organisational performance (Messersmith, Patel, Lepak, & Gould-Williams, 2011). Finally, academic labour markets are anticipated to be dynamic (Baruch 2013) and to turn into suppliers' markets (Melo, Sarrico & Radnor, 2010). As a result, universities can be expected to compete more with both universities (Ringelhan et al. 2013) and organisations external to academia (Lee et al. 2008). Under these labour market conditions, overlooking employer branding methods means forfeiting opportunities to enhance performance and to attract new employees. Universities are appropriately recommended to involve themselves in employer branding independently from labour market settings (Brosi & Welpe, 2014). In order to address the research gap of employer branding in HE, it is imperative to

examine the practices and features pertaining to employment branding that solicit top academics to apply for a position at a HEI.

The main objective of this study was to explore the components of an employment brand that should form part of a talent value proposition for academic staff from the perspective of higher education management.

RESEARCH DESIGN

Research Approach

A research approach comprises the strategies and processes employed in a research study; these range from suppositions to techniques of data gathering, analysis, and interpretation. The choice of a research approach is determined by the nature of the research problem under investigation, the understanding of the researcher, as well as the people whom the study will affect or involve (Creswell, 2014). The nature of the present study necessitated a qualitative approach, as it investigated views of the management of the merged South African HEI on the employment brand, and the population was small. A case study strategy was adopted in this research, as the data gathered were obtained from a real-life setting (Willis, 2008). Themes were extracted from the transcribed semi-structured interviews, and validated against a global perspective, as documented in the available literature. The qualitative case study approach falls within the interpretive/constructivist paradigm (Yin, 2012). In this instance, the ontological belief is that reality is local and specifically constructed.

Sampling

The research setting of this study was a merged South African HEI. The participants were 12 managers of the HEI, and were geographically situated at three different campuses. The participants were interviewed in person at their offices, and, in cases where the campus was too distant to travel to, participants were interviewed via telephone or Skype. Permission to carry out this research was sought and obtained from the relevant authorities of the HEI by means of a letter of request, prior to collection of the data. Upon obtaining permission, the researcher approached the interview candidates personally, requesting to conduct the interviews, and interviewees were required to give consent before answering any of the researcher's questions. Research ethics were upheld, specifically anonymity of the participants.

The table below provides the demographic particulars of the sample.

Table 1: Sample Demographics

Participants	Gender	Race	Qualification	Job Level
1	Male	Black African	Doctorate	Executive management
2	Male	Black African	Doctorate	Senior management
3	Male	Black African	Doctorate	Executive management
4	Female	White	Doctorate	Senior management
5	Male	Black African	Doctorate	Executive management
6	Female	Black African	Doctorate	Senior management
7	Female	White	Doctorate	Senior management
8	Male	White	Doctorate	Executive management
9	Female	White	Doctorate	Middle management
10	Male	Black African	Doctorate	Middle management
11	Female	Black African	Doctorate	Executive management
12	Male	White	Doctorate	Senior management

The majority (58.33%) of the participants were male and black African. All 12 participants held a doctorate, and the distribution in terms of management level was as follows: 41.67% (five participants) in executive management, 41.67% (five participants) in senior management, and 16.67% (two participants) in middle management. Only one (8.33%) of the five participants in executive management was a woman. At senior management level, three of the five participants were women that is 25% of the entire sample. There was one man and one woman in middle management.

Data analyses

Thematic analysis was used to encode the interview responses, documented in a codebook. Klenke (2016) stated that thematic coding distinguishes between manifest themes (themes that are obvious from the data) and latent coding (subtle themes building up to or relating to the greater phenomenon). In accordance with Patton (2015), an inductive approach to data analysis was used, which entailed finding trends, themes, and clusters in the gathered data, thereby generating fresh ideas, findings, and concepts. This research was carried out in a manner that would ensure that the findings would be trustworthy, significant, pertinent, and applicable in practice (Baillie, 2015).

FINDINGS

Table 2 depicts the themes that were identified from the interviews with the management of the HEI under study. The frequency of these identified themes is outlined in descending order in the table below. *Fringe benefits/Incentives and remuneration*, *Leadership and managerial support*, and *Occupational health and safety*, in this order, were the most frequently occurring themes.

Table 2: Frequency of Themes

Theme	Frequency
Fringe benefits/Incentives and remuneration	45
Leadership and managerial support	38
Occupational health and safety	28
Performance management and development	25
Job security	18
Work–life balance and flexibility	15
Fulfilment and purpose	9

Theme: Fringe benefits/incentives and remuneration

Participants affirmed that the salary offered in exchange for service or expertise is the chief elements of an employment brand that ensure institutions remain competitive. This view is supported by the following statements:

I would like to say, 'There is a salary in exchange for that.' That is our first agreement, to ensure that we provide a good package (Participant 1, male, executive management, black African).

Other participants intimated that the HEI still needs to improve on its salaries, evident from the following statement:

I don't think the salary here is better than the salary other academics earn in other universities (Participant 2, male, senior management, black African).

Theme: Leadership and managerial support

This was the second-most important consideration for the participants. Participants believed that management played a crucial role in the success and growth of academics in HEIs, as implied by the following statement:

What we do as a university is really to ensure that, if your heart is truly in academia, we give you that support, so that you achieve what you want, so that, eventually, you also reach the top pinnacle of your career (Participant 1, male, executive management, black African).

Participant 10 also expressed the opinion that the management of the merged South African HEI was providing sufficient support in various ways to their academic staff members, as implied by the following:

I feel, the commitment from management is there, because, every year, we talk about participation, that people should do research, people should do studying, and you'll see, even in terms of our budget, we always make sure that we have a budget to assist academics. And even in terms of performance, you'll find that, if we have a person, like a weaker-performing academic, we even have facilities where you pass through developmental... I mean, it takes time for someone to get a warning to say, 'You're a poor performer' (Participant 10, male, middle management, black African).

Theme: Occupational health and safety

This the third-highest occurring theme. The participants had diverging views regarding the level of safety on the different campuses of the HEI. The prevalent view was that management generally provided sufficient safety measures:

Management is always in control, so academic staff members feel safe. There is good communication. If there will be picketing or a protest, you'll find that, usually, we'll already be aware a day before the time, and there is an SMS system that informs our staff members immediately. Consider how we managed to organise the #FeesMustFall campaign, and, yet, it was so successfully handled, with no violent disruptions, and no one was endangered (Participant 8, male, executive management, white).

On the other hand, there was a perception that management was doing well in terms of safety when working with hazardous equipment or substances, but lacked control of safety with regard to disruptive behaviour on their campus:

I'm not sure about safe yet. In terms of a safe environment, we observe health and safety measures with respect to the laboratories, buildings, and then, from time to time, we ensure that the academic staff is safe, but then the disruptions on campus is something that we don't have enough control over yet (Participant 3, male, executive management, black African).

Theme: Performance management and development

This was the fourth-highest occurring theme. The notion that emerged from the data was that the performance of academic staff in the HEI was closely monitored, with the intention of rewarding those who were performing well in a manner that would facilitate further performance through development, while developing those whose performance was lacking. This can be seen from the following statements:

We have performance agreements through a yearly basis. They indicate what they need, what their needs are, and we also indicate what we expect from them. So, we review after six months, and then we relook into that around September (Participant 11, female, executive management, black African).

Participants also noted the various rewards and advancement systems available to top-performing academic staff:

We've got the Top Performer's bonus, and then we got the merit bonuses, that is, your tangible amount. But, also in terms of the promotion, you don't have to wait until somebody dies to get a promotion. It is actually in your own hands. If you meet the criteria, then you get the promotion, and it's not all universities that have got that (Participant 7, female, senior management, white).

Theme: Job security

Job security was the fifth-highest occurring theme. Participants expressed that job security is generally high in academia, and cited the outstanding track record of the HEI where job security is concerned:

When it comes ... to job security, I think, generally, from my own assessment, I think lectureship is one of the areas where there is high job security, as compared to other jobs. There's a lot of support that you get, and I think it takes something very extreme to, say, you might wake up and find your job is gone. I think this field is one of those where you know, if you get a job, your chances of getting ... to retirement in your job is high (Participant 10, male, middle management, black African).

Another participant stated:

It is secure, because we've got tenure and the majority of academic staff members have got long-term contracts. Therefore, security of tenure is one thing that we do have (Participant 3, male, executive management, black African).

Work-life balance and flexibility

Participants revealed that the decision whether to join a HEI is also greatly influenced by their family situation, as can be identified from the following:

You have to think of your children; that is your family. Where are they going to go to school? (Participant 1, male, executive management, black African).

Participants also indicated the importance of giving academics freedom to pursue their personal ambitions, which may not form part of their employment agreement, as indicated by the following response:

Even if it means you have to take some time away from the university to take part in those activities where your talent is sharpened and you are further refined, then we have to give you that opportunity. It won't be like, 'No, you can't go and do this, because we want you to be teaching every day.' We create space for you, so that, even other, additional resources that are needed, they give you, and that helps a lot (Participant 10, male, middle management, black African).

DISCUSSION AND CONCLUSIONS

The objective of this research was to explore management's views on the factors affecting the employment brand of a South African HEI. The findings of the present study suggest that seven themes, namely *Fringe benefits/Incentives and remuneration*, *Leadership and managerial support*, *Work-life balance and flexibility*, *Performance management and development*, *Occupational health and safety*, *Job security*, and *Fulfilment and purpose* are fundamental to a desirable and enticing employment brand of a HEI and should form part of its talent value proposition.

Fringe benefits/Incentives and remuneration was the most-discussed issue amongst the participants in this study. The participants concurred that a competitive salary, together with benefits and incentives, is crucial to creating a desirable employment agreement in a HEI, and that it will attract the superior academic talent. *Leadership and managerial support* was the second-most popular topic among participants in this study. Participants agreed that leadership has an important influence on the success of academic staff. *Occupational health and safety* of academic staff members was the third-most mentioned topic pertaining to employment branding. All the participants in this study agreed that workplace safety is crucial to ensuring a vibrant employment experience. *Performance management and development* was the fourth-most discussed issue among the participants in this study. They explained that the academic staff members in the merged South African HEI are continuously monitored over a six- to 12-month period, to ensure the optimal performance and growth of academics.

The present research makes important theoretical and practical contributions. From a theoretical perspective, this study adds to the limited empirical knowledge on the employment branding of HEIs and the implications thereof for the effective talent management of academic staff. From a practical point of view, this research identified the key elements that should form part of an appealing HEI's employment brand that will attract and retain current and future talent. HR practitioners and HEI management are encouraged to reconsider the remuneration structure of academic staff members, as it appears to be an important determinant in attracting and retaining talent, in order to ensure the future success and sustainability of HEIs.

This research has some limitations. Due to the minimal available research on employment branding, the researcher was faced with the limitation of having to seek much of the validation from studies outside the academic arena. The nature of the work of individuals in HE managerial positions also posed a limitation for the researcher, as it was quite challenging to secure their participation. Several managerial staff members withdrew from the study after initially agreeing to participate, due to pressing work matters. The study also focused on only one HEI. As a result, the findings cannot be generalised to other HEIs.

The researcher recommends that further inquiry be made into the merged South African HEI, in order to obtain the views of current academic employees concerning the existing employment brand, so that improvements can be made to it. The researcher also recommends that an inquiry be conducted among the support staff of the HEI, as it is also important to have an appealing employment brand for them.

REFERENCES

- Amber, T., & Barrow, S. (1996). The employer brand. *Journal of Brand Management*, 4(3), 185-206.
- Annapoorna, M. S. (2015). A study on employer branding with reference to higher education sector in Tumkur city with special focus on management colleges in Tumkur city. *International Multidisciplinary e-Journal*, IV(VIII), 285-294.
- Baillie, L. (2015). Promoting and evaluating scientific rigour in qualitative research. *Nursing Standard*, 29(46), 36-42.
- Brosi, P., & Welp, P. M. (2014). Employer branding for Universities: What attracts international postdocs? *Journal of Business Economics*, 1-34.
- Creswell, J. W. (2014). *Research design: Qualitative, quantitative, and mixed methods approaches* (4th ed.). Thousand Oaks, California: SAGE Publications.
- Edwards, M. R. (2010). An integrative review of employer branding and OB theory. *Personnel Review* 39(1), 5-23.

- Evans, L., & Nixon, J. (Eds.). (2015). *Academic identities in higher education: The changing European landscape*. London, U.K.: [Bloomsbury](#).
- Francis (2006). A critical discourse perspective on managers experiences of HRM. *Qualitative Research in Organizations and Management: An International Journal*, 1(2), 65-82.
- Finney, M. I. (2008). *Building high-performance people and organisations*. Westport, CT: ABC-CLIO.
- Fitz-enz, J. (2010). *The new HR analytics: predicting the economicvalue of your company's human capital investments*. New York, NY: AMACOM.
- Hargens, L. L. (2012). Academic labour markets and assistant professors' employment outcomes. *Research in Higher Education*, 53, 311-324.
- Klenke, K. (2016). *Qualitative research in the study of leadership* (2nd ed.). Bingley, UK: Emerald Group Publishing.
- Knox, S., & Bickerton, D. (2003). The six conventions of corporate branding. *European Journal of Marketing*, 37(7-8), 998-1016.
- Martin, G., Burke, R. J., & Cooper, C. L. (Eds.). (2011a). *Corporate reputation: Managing opportunities and threats*. Farnham Surrey, England: Gower Publishing.
- Martin, G., Gollan, P. J., & Grigg, K. (2011b). Is there a bigger and better future for employer branding? Facing up to innovation, corporate reputations and wicked problems in SHRM. *The International Journal of Human Resource Management*, 22(17), 3618-3637.
- Melo, A. I., Sarrico, C. S., & Radnor, Z. (2010). The influence of performance management systems on key actors in universities: the case of an English university. *Public Management Review*, 12, 233-254.
- Messersmith, J. G., Patel, P. C., Lepak, D. P., & Gould-Williams, J. S. (2011). Unlocking the black box: exploring the link between high-performance work systems and performance. *Journal of Applied Psychology*, 96, 1105-1118.
- Muncherji, N., Gopalakrishnan, C., & Dhar, U. (Eds.). (2009). *Partners in success: Strategic HR and entrepreneurship*. New Delhi: Excel Books India.
- Parry, E., & Tyson, S. (2013). *Managing people in a contemporary context*. Abingdon, OX: Routledge.
- Patton, M. Q. (2015). *Qualitative research & evaluation methods: Integrating theory and practice* (4th ed.). Thousand Oaks, California: SAGE Publications.
- Robinson, L. (Ed.). (2014). *Marketing dynamism & sustainability: Things change, things stay the same...: Proceedings of the 2012 Academy of Marketing Science (AMS) Annual Conference*. New York, NY: Springer.
- Savignano, M. (2007). *The multiple identities of an employer: A case study on DHL* (Master's thesis). Retrieved from <http://www.grin.com/en/e-book/162729/the-multiple-identities-of-an-employer>
- Sehgal, K., & Malati, N. (2013). Employer branding: A potent organisational tool for enhancing competitive advantage. *IUP Journal of Brand Management*, X(1), 51-65.
- Sparrow, P. R., & Cooper, C. L. (2011). *The employment relationship: Key challenges for HR*. New York, NY: Routledge.

Srivastava, P., & Bhatnagar, J. (2010). Employer brand for talent acquisition: An exploration towards its measurement. *Vision. The Journal of Business Perspective*, 14(1/2), 25-34. doi: 10.1177/097226291001400103

Sullivan, J. (2004). The 8 elements of a successful employment brand. *ERE Media*. Retrieved from <http://www.ere-media.com/ere/the-8-elements-of-a-successful-employment-brand/>

Torress-Coronas, T. (Ed.). (2008). *Encyclopedia of human resources information systems: Challenges in e-HRM*. New York, NY: IGI Global.

Zinger, D. (2013, April 9). A design conundrum: Employee engagement and a 2-day employee value proposition workshop [Web log post]. Retrieved from <http://www.davidzinger.com/employee-engagement-and-a-2-day-employee-value-proposition-workshop-14160/>

Willis, J. W. (2008). *Qualitative research methods in education and educational technology*. Charlotte, NC: Information Age Publishing.

Yin, R. K. (2012). *Applications of case study research* (3rd ed.). Thousand Oaks, Cblications.

FREQUENCY OF APPLICATIONS OF SYSTEMATIC REVIEWS IN EVIDENCE SYNTHESIS IN MANAGEMENT RESEARCH: A SCOPING REVIEW OF SOUTH AFRICAN PRACTICES

Chris Schachtebeck, University of Johannesburg, South Africa
Lehana Thabane, McMaster University, Canada

ABSTRACT

A wide range of frequently used methodological tools exist in other disciplines, yet are often not utilized in the management sciences. Tools such as systematic reviews are useful to objectively review, summarize, and appraise the results of published studies to guide practice or identify gaps in knowledge that require further research. The aim of this scoping review is to ascertain to what extent systematic reviews are utilized in South African management research. We employed a scoping review methodology and searched a number of prominent management databases. No limits on publication dates were set. Data was analyzed by means of charting. 9880 studies were identified during an initial search. From these 204 were assessed for eligibility, which 32 articles met. It was found that systematic reviews comprise 0.09% of South African managerial studies. An increase in the utilization was observed from 2014 onwards, yet systematic reviews are severely under-utilized in South African management research. A roadmap identifying crucial steps in systematic reviews and best practices is provided.

Keywords: systematic review, scoping review, South Africa, management sciences.

INTRODUCTION

Systematic and scoping reviews of published literature plays an integral part in synthesis and critical appraisal of published evidence to guide research, practice and policy (Grant & Booth, 2009). The role of reviewing literature is to describe, summarize, evaluate and outline concepts in a particular subject area. It provides not only the empirical basis for a study, but also much needed context by examining the strengths and limitations of existing evidence on a topic. It enables researches to justify their research, highlight gaps in existing literature, ensure the research has not been conducted previously and aids in refining and focusing the research topic (Boote & Beile, 2005).

Systematic reviews were first applied in the 1970s in the medical sciences and have recently gained increased prominence in other disciplines, particularly as systematic reviews improve the rigor and depth of literature reviews and searches (Mallett *et al.*, 2012). Yet in South Africa, there seems to exist a poor understanding and under-appreciation of systematic reviews as an acceptable research method (Ham-Baloyi & Jordan, 2016). Research, in particular original primary research, conducted by higher education institutions and businesses, is both costly and time-intensive (Walwyn, 2008). The additional benefit of reviewing results of existing research in a systematic manner can also be attributed to a reduction in cost, which is paramount in the South African economic environment, characterized by sluggish economic growth and decline in real spending power (Schussler, 2016). Yet despite their wide-spread use in health and the social sciences, it has not been established to what extent systematic reviews are used in management research, practice and policy making, and with what frequency.

LITERATURE REVIEW

The Nature of Systematic Reviews

Systematic reviews, by virtue of their nature, utilize a transparent and methodical process to “define a research question, search for studies, assess their quality and synthesize findings qualitatively or quantitatively” (Armstrong, Hall, Doyle & Waters, 2011:147). It is however of the essence that the scope of the research question is delineated prior to conducting the review, thereby implying that the researchers have clear understanding of the conceptual nature, definitions and existing literature of the topic under investigation (Arksey & O’Malley, 2005; Armstrong *et al.*, 2011). Mallett *et al.* (2012:447) highlight the bias traditional literature reviews introduce, by stating that “traditional literature reviews are all too often restricted to literature already known to the authors, or literature that is found by conducting little more than cursory searches”. Systematic reviews are therefore beneficial in reducing researcher bias. Wiysonge (2014:1) states that “systematic reviews provide a complete picture of the totality of evidence on a given topic” and is “comprehensive enough to avoid publication, language and indexing biases”. In the medical sciences, systematic reviews are frequently utilized as they provide “explicit, systematic methods aimed at limiting systematic error (bias) and reducing the chance of effect”, and “receive twice as many citations as non-systematic reviews in peer-reviewed journals” (Mickenautsch, 2011:20).

Abdulla and Krishnamurthy (2016) state that systematic reviews go further than traditional literature reviews in that literature reviews merely provide an overview of a topic and aim to frame an author’s discussion, while systematic reviews aim to locate all relevant studies to the topic in question. The authors further explain that systematic reviews are methodical and answer a clearly defined research question, rather than merely offering background reading. Of vital importance, for a number of reasons, is however the role of researcher in systematic reviews, as the researcher is both the choral director and part of the ensemble. Firstly, the researcher should conduct a thorough search in order to capture all important studies. Secondly, the conclusions reached from systematic reviews cannot exceed the level of the studies reviewed. Thirdly, biases should be critically assessed in discovered studies. Lastly, the researcher should possess an understanding of the key issues being investigated, in order to draw valid conclusions and spot any potential bias (Wright *et al.*, 2007).

The importance and nature of systematic reviews can be summarized by the fact that they increase the value of existing research. Wiysonge (2014:2) goes as far as suggesting that “research funders and regulators should demand that proposals for additional primary research are justified by systematic reviews showing what is already known, and increase funding for the required syntheses of existing evidence”. Ham-Baloyi and Jordan (2016) however warn that systematic review may require significant amount of time if a large body of evidence is discovered. Additionally, universities and other institutions may have challenges in both finding staff members who are skilled at performing systematic reviews, and publishing systematic reviews in peer-reviewed journals as it is an under-appreciated research method (Ham-Baloyi & Jordan, 2016).

Systematic vs Scoping Reviews

Similarities exist between systematic and scoping reviews in that they share characteristics such as a systematic approach to data collection, as well as being transparent and replicable (Grant & Booth, 2009). Grant and Booth (2009:95) describe scoping reviews as a “preliminary assessment of potential size and scope of available research literature. Aims to identify nature and extent of research evidence (usually including ongoing research)”, while a systematic review “seeks to systematically search for, appraise and synthesis research evidence, often adhering to guidelines on the conduct of a review”. The provided definitions indicate that systematic reviews are more comprehensive in nature, as they allow researchers to determine possible gaps in literature, synthesize and combine the results of existing studies, as well as anticipate problems in potential future studies (Shamseer *et al.*, 2014). It is suggested that the results from a scoping review inform the researcher whether a full systematic review is necessary/required. Scoping reviews are often also referred to as ‘mapping’ reviews, as they not only clarify definitions, but also set conceptual boundaries in the field of interest. “Scoping reviews are therefore of particular

use when a body of literature has not yet been comprehensively reviewed, or exhibits a large, complex or heterogeneous nature not amenable to a more precise systematic review (Peters *et al.*, 2015:141).

Guidelines for Systematic Reviews

Mulrow (1994) explains that systematic reviews are an invaluable scientific tool. However, a successful systematic review is grounded in several premises. Firstly, a large number of studies are reduced into a more workable format. Secondly, a methodologically correct systematic review allows for separation between unimportant or uninformative studies and critical studies containing vital information. Thirdly, systematic reviews, while labor and time-intensive, are usually a more efficient tool than conducting an entirely new study. Lastly, findings derived from systematic reviews can be generalized as the information derived from the review is based on a large number of other studies utilizing sound scientific principles (Mulrow, 1994).

Kitchenham (2004) and Victor (2008) state that systematic reviews need to include a number of vital components and steps, these should include: to establish a clear need for reviewing systematically by interrogating the topic in question, as well as purpose of the study; to define review scope, questions and protocol; to develop review protocol outlining steps to be followed; to define inclusion and exclusion criteria; to appraise quality of identified studies in terms of criteria stated in protocol; to extract and synthesize data according to developed template; and to report on results of systematic review. In order to avoid any ethical issues when preparing and publishing systematic reviews, it is advisable to carefully approach areas of concern. One such area is authorship, in that the authoring of systematic review articles should follow common publishing practices, which include the first author being the party who performed most of the work. A second area of concern is to avoid redundant and duplicate publications, as these can skew statistical analyses. Thirdly, plagiarism should be avoided by citing other author's works. Fourthly, any conflict of interest and funding sources should be disclosed. Fifthly, accuracy in performing and reporting systematic reviews is of paramount importance, as such reviews are often form the basis of decision-making. Lastly, any suspicions of plagiarism or fraudulent research discovered during a systematic review should be raised with the relevant publishers (Wager & Wiffen, 2011).

RESEARCH METHODOLOGY

The research was qualitative in nature and made use of a scoping review. Scoping reviews were selected as the appropriate review method as they do not aim to assess the quality of the discovered literature, but rather map relevant literature in the subject field of study (Arksey & O'Malley, 2005). The study aimed to establish the frequency of systematic review use and not assess the quality or constructs of discovered studies. In particular, scoping reviews are regarded as an ideal tool where information on the nature, extent and range of specific research activity is sought (Arksey & O'Malley, 2005).

The research was guided by the question: *'To what extent are systematic reviews used in South African management research?'*. Keywords were utilized to answer the research question. These included: **"systematic review"**, **"systematic reviews"** and **"South Africa"**. The aim of the research was therefore to determine the prevalence of use of systematic review methodology in management research conducted in South Africa.

We searched the following databases: Ebscohost (Business Source Complete); Emerald Insight; Proquest Business Collection; Sabinet African Electronic Publications (SAePublications), including African Journal Archive; and Gale Business Insights: Global, from beginning up to March 22, 2017. Databases were selected due to their extensive use in South African management research. To allow for a comprehensive review, no limits were set on date ranges, language or subject type, provided the research fell within the general area of management studies. Search terms were adapted for specific use in each database. The identified keywords were utilized in a Boolean search in each database. Boolean operators such as 'OR' and 'AND' were utilized in the search string. Selected keywords could appear in the title, keywords, text or abstract. The following search string was utilized as a basis for the review: ("*systematic review*" OR "*systematic reviews*") AND ("*South Africa*").

Each discovered article was screened by means of inclusion and exclusion criteria. Inclusion criteria included the articles being available as full-text; articles written in English; the article topic lying in the field of management; the study being conducted in South Africa; the methodology utilizing a systematic review. Exclusion criteria were set as: article only available as abstract; articles written in any other language other than English; non-management area of focus. After a preliminary search, the discovered articles were screened against the inclusion and exclusion criteria. Articles accepted for further assessment were analyzed by means of charting. Charting “describes a technique for synthesizing and interpreting qualitative data by sifting, charting and sorting material according to key issues and themes” (Arksey & O’Malley, 2005). Further analysis and presentation of data took the form of a data charting form. The form contained the following headings: Year of Publication, database, sub-field of research. The data was utilized to produce numerical analysis by means of tables and charts. Grant and Booth (2009) state that results obtained from scoping reviews are usually summarized in a tabular fashion with narrative commentary, in order to conduct a preliminary assessment of the size and scope of available literature.

FINDINGS

Firstly, the prevalence of management-related articles in the utilized databases were established to provide a measurement baseline. The utilized databases contain a large number of articles related to the field of management in South Africa, with Ebscohost containing 6260 articles, Emerald containing 888 articles, Sabinet containing 26884 articles, Proquest containing 2025 articles and Gale containing 338 articles. A total of 36395 articles related to management sciences can therefore be found across these databases. The initial database search for studies utilizing a systematic review methodology yielded a total of 9880 articles across five prominent databases. After an initial screening to only include articles falling within the management sciences, a total of 204 relevant articles were discovered. After screening the discovered articles against the set inclusion criteria, a total of 32 articles met inclusion criteria. 172 articles were discarded for a variety of reasons, such as not focusing on South Africa, or not utilizing systematic reviews. A summary of the findings at each stage of the research can be observed in Figure 1.

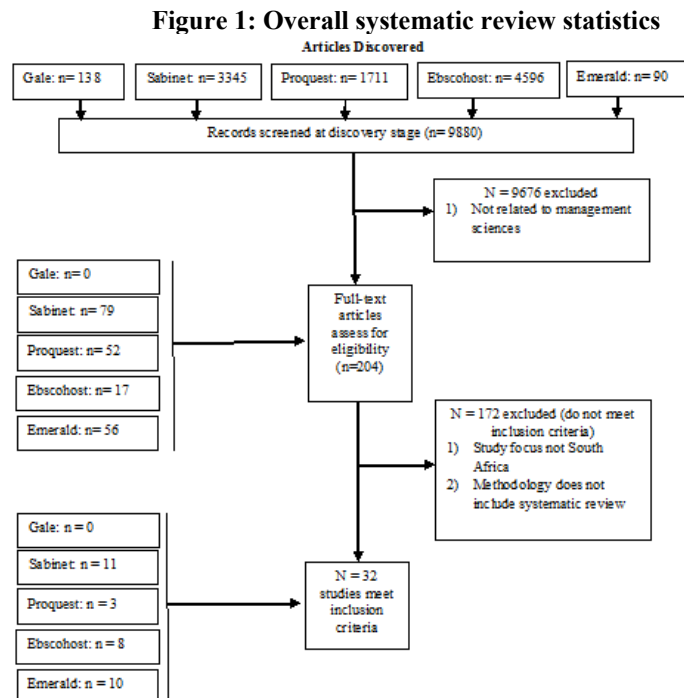

Source: Authors’ calculations

At this stage, it was troubling to note that only 32 out of 36395 articles utilized a systematic review methodology. This equates to a utilization of 0.09%. After the initial screening, an in-depth review of each article

was undertaken. The results of the review are outlined in Table 1 in terms of academic sub-field in the management sciences, year of publication and database.

Table 2: Preliminary Results of Systematic Review

Date Range	Major sub-fields	N	% of discovered studies	Inverse Cumulative %
<2000	Industrial Psychology (1);	1	3.1%	100%
2000-2005	Development Economics (1)	1	3.1%	96.9%
2006-2010	Marketing Management (1); Business Management (1); Industrial Psychology (2)	4	12.5%	93.8%
2011-2013	Development Economics (2); Industrial Psychology (2); Human Resource Management (1); Business Management (1); Financial Management (2)	8	25%	81.3%
2014-2015	Marketing Management (1); Industrial Psychology (5); Human Resource Management (2); Business Management (3); Financial Management (1)	12	37.5%	56.3%
2016-2017	Industrial Psychology (2); Human Resource Management (1); Business Management (2); Supply Chain Management (1)	6	18.8%	18.8%
		32	100%	

Source: Authors' calculations

The table reveals that only a small number of systematic reviews were conducted in the management sciences, therefore indicating that utilization of systematic review methodology is not widespread in this discipline. It also becomes evident that the vast majority of systematic reviews were conducted after 2010, with 26 out of the 32 discovered articles (81.3%) published post-2010. 18 out of 32 (56.3%) systematic reviews were conducted after 2014. There has thus been a marked growth in the use of systematic review methodology in the management sciences since 2010, therefore indicating that this type of methodology is gaining. A further table (Table 2), was developed to indicate the percentage of discovered articles by management sub-field.

Table 2: Scoping Review Findings by sub-field

Major sub-fields	N	% of discovered studies
Industrial Psychology	12	38%
Business Management	7	22%
Human Resource Management	4	13%
Financial Management	3	9%
Development Economics	2	6%
Marketing Management	2	6%
Supply Chain Management	1	3%
Economics	1	3%
	32	100%

Source: Authors' calculations

The majority of systematic reviews in the management sciences are in the sub-fields of Industrial Psychology (38%), Business Management (22%) and Human Resource Management (13%). Other sub-fields

included Supply Chain Management (3%), Development Economics (6%), Marketing Management (6%) and Financial Management (9%). As Industrial Psychology and Human Resource Management can be regarded as sister disciplines, it becomes evident that systematic reviews in the management sciences are mainly used within this field (51%).

CONCLUSION & RECOMMENDATIONS

The objective of this research was to determine the frequency of application of systematic reviews in the South African management sciences. A scoping review was conducted to determine the frequency of application. Results from the scoping review indicate that systematic reviews are under-utilized in the management sciences, with only 32 articles being discovered that utilized this type of methodology, representing 0.09% of articles related to the management sciences. While the number of discovered systematic review articles is minute, it is noteworthy that the majority of discovered systematic reviews can be found in the fields of Human Resource Management, Industrial Psychology and Business Management. A marked increase in utilization of this methodology can be observed from 2010 and in particular from 2014 onwards. This indicates that researchers and academics are becoming familiar with this type of methodology, and are beginning to appreciate the value that systematic reviews hold.

Benefits of systematic reviews include the provision of an unbiased and repeatable literature discovery process. Systematic reviews allow researchers to consolidate and synthesize large volumes of data, thereby providing additional data discovery and insight, eliminating the need for additional primary research. This benefit is of importance to academia and businesses alike, as systematic reviews provide a relatively low-cost alternative to costly and time-intensive original primary research. These interest groups face an economic environment in South Africa that is characterized by lack of spending, slow economic growth and limited funding opportunities.

It is recommended that South African academics, researchers and business in the field of management utilize the systematic review methodology to a greater extent. This further has the impact that these stakeholders need to familiarize themselves with this type of methodology. The methodology therefore needs to be promoted more actively by universities, academics and methodologists. The value and uniqueness of the research lies in the fact that no study has aimed to establish extent of use of systematic reviews in South Africa. Following the findings and recommendations, Figure 2 outlines a recommended roadmap, for managerial and academic use, showing application of the systematic review methodology, together with examples of best practices.

Figure 2: Roadmap for application of systematic review methodology

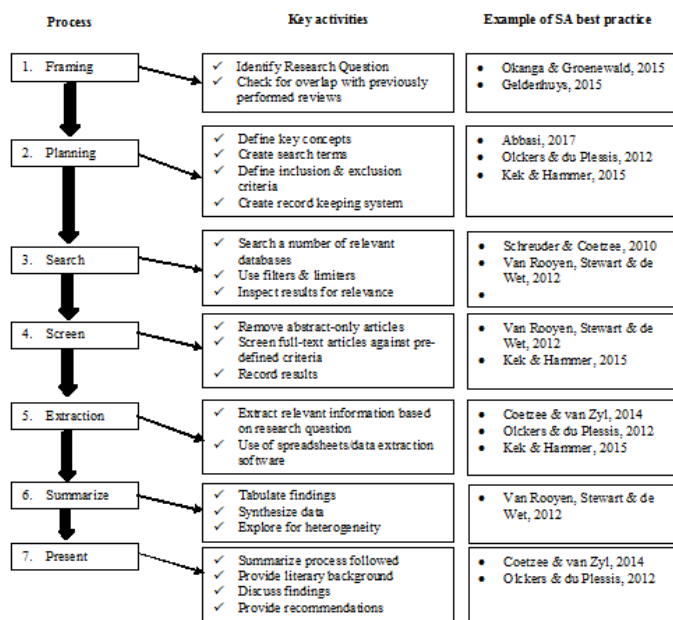

Adapted from: Siddaway (n.d.) & Khan *et al.*, (2003)

The roadmap outlines the recommended steps to be followed for a thorough systematic review, as well as the key activities involved at each step. Lastly, the figure indicates best practices from South African literature as identified during the scoping review process.

REFERENCES

- Abbasi, M. (2017). Towards Socially Sustainable Supply Chains – Themes and Challenges. *European Business Review*, 29(3), 1-38.
- Abdulla, A. & Krishnamurthy, M. (2016). Comparing retrieval of systematic review searches in health sciences areas using two major databases. *Reference Reviews*, 30(8), 1-5.
- Arksey, H. & O'Malley, L. (2005). Scoping studies: towards a methodological framework. *International Journal of Social Research Methodology*, 8(1), 19-32.
- Armstrong, R., Hall, B.J., Doyle, J. & Waters, E. (2011). 'Scoping the scope' of a Cochrane review. *Journal of Public Health*, 33(1), 147-150.
- Coetzee, M. & Van Zyl, L.E. (2014). A review of a decade's scholarly publications (2004–2013) in the South African Journal of Industrial Psychology. *SA Journal of Industrial Psychology/ SA Tydskrif vir Bedryfsielkunde*, 40(1), 1-16.
- Geldenhuys, D.J. (2015). Social constructionism and relational practices as a paradigm for organisational psychology in the South African context. *SA Journal of Industrial Psychology/SA Tydskrif vir Bedryfsielkunde*, 41(1), 1-10.
- Grant, M.J. & Booth, A. (2009). A typology of reviews: an analysis of 14 review types and associated methodologies. *Health Info Libr J*, 26(2):91-108.
- Ham-Baloyi, W.T. & Jordan, P. (2016). Systematic review as a research method in post-graduate nursing education. *Health SA Gesondheid*, 21, 120-128.
- Kek, M.Y.C.A. & Hammer, S. (2015). Theorising Academic Development as an Academic Discipline? Exploring Academic Developers' Ways of Knowing, Theorising and Use of Methods. *In Theory and Method in Higher Education Research*. Published online: 29 Sep 2015; 235-255.
- Khan, K.S., Kunz, R., Kleijnen, J. & Antes, G. (2003). Five steps to conducting a systematic review. *Journal of the Royal Society of Medicine*, 96(3), 118–121.
- Kitchenham, B. (2004). *Procedures for Performing Systematic Reviews*. NICTA Technical Report. Available online from: <http://www.inf.ufsc.br/~aldo.vw/kitchenham.pdf> (Accessed 2 February 2017)
- Mallett, R., Hagen-Zanker, J., Slater, R. & Duvendack, M. (2012). The benefits and challenges of using systematic reviews in international development research. *Journal of Development Effectiveness*, 4(3), 445-455.
- Mickenausch, S. (2011). Editorial: About the value of systematic reviews in clinical dentistry. *Evidence based Summaries in Dentistry*, 1(2):19-28.
- Mouton, J. & Muller, J. (1998). Tracking trends in theory and method: Past and future. Programme evaluation: A structured assessment. In J. Mouton, J. Muller, P., Franks, T. & Sono (Eds.). *Theory and method in South African human sciences research: Advances and innovations*. Pretoria: HSRC, 255-268.
- Mulrow, C.D. (1994). Systematic Reviews: Rationale for systematic reviews. *BMJ*, 309, 597-599.

- Okanga, B. & Groenewald, D. (2015). Effectiveness and efficiency of the delivery systems of the e-retail enterprises in South Africa. *Journal of Contemporary Management*, 12(1):838-861.
- Olckers, C. & Du Plessis, Y. (2012). The role of psychological ownership in retaining talent: A systematic literature review. *SA Journal of Human Resource Management/SA Tydskrif vir Menslikehulpbronbestuur*, 10(2), 1-18.
- Peters, M.D.J., Godfrey, C.M., Khalil, H., Mcinerney, P., Parker, D. & Soares, C.B. (2015). Guidance for conducting systematic scoping reviews. *International Journal of Evidence Based Healthcare*, 13, 141-146.
- Schreuder, D., & Coetzee, M. (2010). An overview of industrial and organisational psychology research in South Africa: A preliminary study. *SA Journal of Industrial Psychology/SA Tydskrif vir Bedryfsielkunde*, 36(1), 1-11.
- Schussler, M. (2016). What long-term slow growth means for SA : economic outlook. *Personal Finance Newsletter*, March 2016, 15-16.
- Shamseer. (1994). Systematic Reviews: Rationale for systematic reviews. *BMJ*, 309, 597-599.
- Siddaway, A. (n.d.). What is a systematic literature review and how do I do one? Available online from: <https://www.stir.ac.uk/media/schools/management/documents/centregardresearch/How%20to%20do%20a%20systematic%20literature%20review%20and%20meta-analysis.pdf> (Accessed 8 April 2017).
- Van Rooyen, C., Stewart, R. & de Wet, T. (2012). The Impact of Microfinance in Sub-Saharan Africa: A Systematic Review of the Evidence. *World Development*, 40(11), 2249–2262.
- Victor, L. (2008). Systematic reviewing. *Social research update*, 54, 1-4.
- Wager, E. & Wiffen, P.J. (2011). Ethical issues in preparing and publishing systematic reviews. *Journal of Evidence-Based Medicine*, 4, 130-134.
- Walwyn, D.R. (2008). A comparison of the cost of research in South Africa's public research and higher education institutions. *South African Journal of Science*, 104(11-12), 431-435.
- Wiysonge, C.S. (2014). The importance of systematic reviews in radiology. *South African Journal of Radiology*, 18(1), 1-2.
- Wright, R.W., Brand, R.A., Dunn, W. & Spindler, K.P. (2007). How to write a Systematic Review. *Clinical Orthopaedics and Related Research*, 455, 23-29.

ASSESSMENT OF EMPLOYEE EMPOWERMENT ON SERVICE QUALITY IN SOUTH AFRICA

Kehinde Sobiyi, Nelson Sizwe Madonsela, and Bhekisipho Twala
University of Johannesburg, South Africa

ABSTRACT

Employees are the cornerstone for creating a competitive advantage for any organisation. It is practically unthinkable for a business organisation to get by without building customer satisfaction and high consumer loyalty is speculated to be connected to the execution of the organization. Empowerment is a procedure among which employees are urged to think and given control of their work keeping in mind the end goal to settle on choices that will profit both the organisation and the employees. With a notion that service quality is articulated on how an organisation interact with both internal and external customers in order to create a brand image, royalty, perception as well as customer satisfaction. Today's industries have seen several drivers in their respective business environments, which requires serious attention to sustain an organization's competitive advantage in term of employment and customer retention based on the logical relationship between customer satisfaction and employee satisfaction. Therefore, it is pivotal that organization establishes the best practices and techniques, to name but; we have observed the emerging of workforce engagement, customer focus and process focus concepts as elements of best practices. This paper gives an assessment of employee empowerment in South African organisations on service quality and how it impacts the satisfaction and expectations of consumers.

Keywords: Service quality, consumer satisfaction, employee empowerment, consumers, South Africa.

INTRODUCTION

Consumers around the world prefer good quality products and are highly concerned about the level of quality service they received. The world is developing in an undeniably quick changing environment. Business markets have become much more competitive (Cudjoe *et al.*, 2015). Several aspects including, high demands from stakeholders, increased globalization, technology innovations, shortages of critical skills and increasing workforce diversity (Mayfield & Mayfield, 2002) categorize the business environment. Businesses in South Africa is becoming highly unstable and are becoming more competitive; they are constantly facing enormous pressure to excel in their performance and bring about large-scale changes in order to cope with the economic challenges in the country (Stander and Rothmann, 2009). In this regard, companies have to build resources, competencies, strategies to respond proactively to the economic challenges therefore, they recruit and train new staff from time to time (Stander and Rothmann, 2009; Hedge and Borman, 2012). The implication of the unstable nature of the South African industry tends to have consequences on quality service delivery. Nowadays, organizations are more concerned with the recognition and enhancement of components of work environment that leads high levels of employee satisfaction, and consequently, identify and minimize the factors associated with increasing levels of employee dissatisfaction (Ferguson *et al.*, 2011). High rate of absenteeism and lower turnover are common consequences of low levels of employee job satisfaction whereas, high level of employee job satisfaction leads to higher engagement of employees at work and increased level of commitment, enthusiasm and inspiration (Salazar *et al.*, 2006; Sarwar and Khalid, 2011, Qasim, Cheema & Syed 2013). Employees are the cornerstone for creating a competitive advantage and usually considered as the primary source of productivity gains in many successful businesses, and they are regarded as an asset to such organisations organization (Qasim, Cheema and Syed, 2013). According to Robinson (1997), empowerment is defined as the concept of creating the ability to make decisions, provide information and skills on enhancing the performance of one's assigned task.

Empowerment is a procedure among which employees are urged to think and given control of their work, keeping in mind the end goal that will profit both the organization and the employees. It is also the potential relationship between the organization, its managers and its employees, which comprises of components of trust and a confidence in the abilities and capacities of employees in an organization. A vital aspect of an effective organization is employee empowerment (Bartram and Casimir, 2006). Employee empowerment sets up trust amongst management and employees, this prompts work fulfilment; if employees are cheerful they will be an influence service quality (Spreitzer, 1995). Employees want to be valued by the organization and their efforts towards the success of the organization, the efforts of employees that contribute towards the success of the organization's service quality and to the world as whole must be recognized. In the organization that equip employees with the open door and adaptability, workers are encouraged, they feel more certain, and resolute to work more successfully and effectively.

This paper gives an assessment of employee empowerment in South African selected organizational sectors on service quality and how it affects the satisfaction and expectations of consumers.

SERVICE QUALITY CONCEPT

According to (Looy *et al.*, 2003), service is an action that can be offered to a customer that is important and its output does not lead to ownership. (Zeithaml *et al.*, 2006), use the simplest definition; service is activity, performance and practices. Service quality for organisations is vital in becoming more competitive in the industry; how satisfied the customers are, relies on the service quality it is offered to them. The service provided to customers by organisations increases the perception of customers about the company. (Gronroos, 2007) defines service quality as the results of comparison of consumer's expectations and perception.

Everything contributing to the service offered to customers is considered in the whole process until the end. Organisation finds it difficult to understand the important factors of the service that contribute to high quality to the consumers and how it must be provided (Sureshchander *et al.*, 2002). Employees can deliver high quality service to customers if they understand ways into customer perception of service quality. The ability to put the needs of customers first and understanding their frustration or needs plays a vital role.

SERVICE QUALITY MODEL

The Gap model or SERVQUAL model is service quality structure created by Parasuraman in the mid 80's (Parasuraman *et al.*, 1985). SERVQUAL is a way to gauge the size of value in the service areas and the model is useful in characterising the service quality. The service quality consists of both service and methods of service delivery. The SERVQUAL is a model that has been used by organisation for decades. Organisations compete better when they know and understand the expectations of consumers of the quality and how it is influenced. The customer quality service is the comparison of the actual service performance and customers' actual expectations.

The Five Gaps on the organisation side of model.

Parasuraman *et al.* (1985), through empirical research work on service quality identified five distinct gaps between customer's expectations and what they perceive they receive. The interdependent of the five gaps is shown in Figure 1. The gaps are as follows;

- Knowledge gap
- Standards gap
- Delivery gap
- Communications gap
- Expected service perceived service gap

Figure 1: Gap Model of Service Quality (Parasuraman *et al.* (1985))

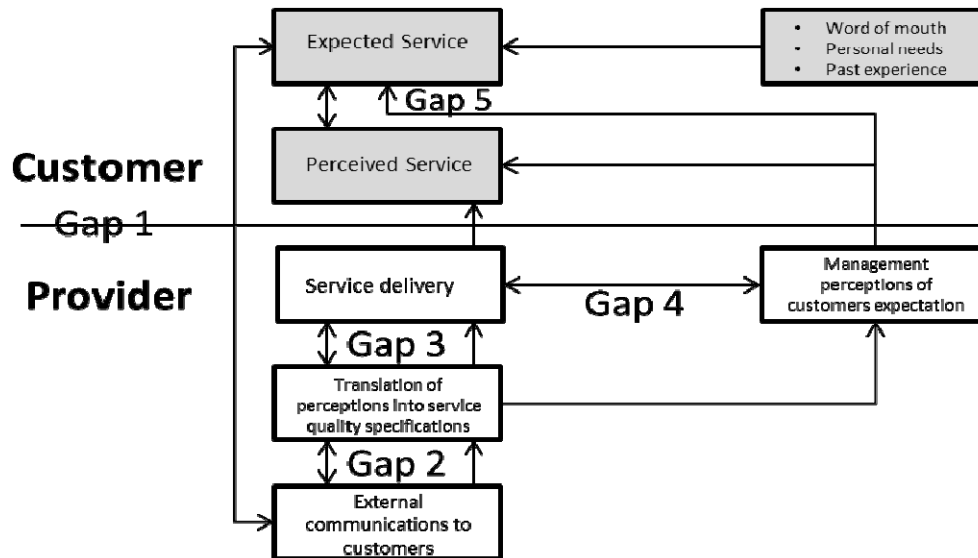

SERVICE QUALITY DIMENSIONS

Olaleke (2010), states that service quality is a focused evaluation reflecting the customers' perception of service features, such as physical environmental quality, interaction quality, and outcome quality. The main criteria that count in assessing service quality, are those characterized by the clients. These components are assessed, in view of particular quality measurements. They are as follows;

- **Tangibility:** It involves the physical confirmation of the service. Images and signal quality are normally conveyed by firms using tangibles (Zeithaml *et al.*, 2006). The tools that are used to deliver service or material used to give quality service.
- **Reliability:** It is the capability to accomplish promised service reliably and precisely and conveying on its quality. The organisation has to provide promised service and keep customers informed about when the service will be performed
- **Assurance:** It is the ability of employees to show loyalty and certainty to customers using their trust and confidence.
- **Responsiveness:** It involves providing service speedily and mindfully (Cudjoe *et al.*, 2015).
- **Empathy:** Commitment of employees to care for customers and give them enough recognition. It also refers to ability to put customers' needs first and understanding their frustrations needs and providing expected services (Zeithaml *et al.*, 2006).

CONCEPT OF EMPLOYEE EMPOWERMENT

Menon (2001) conceptualised empowerment as a process, act or a state. It was further categorised into three namely motivational empowerment (psychological empowerment), structural empowerment, and leadership empowerment. Empowerment is used to create and build trust between management and employees thus, encouraging their contribution towards organisational effectiveness. Empowerment can be used to enhance the employee satisfaction in organisations in accomplishing high level of team work, cooperation, fearlessness, development, free thinking and self-confidence (Elnaga & Imran, 2014). Empowerment is management practise through which management share information, rewards employees, grant power to employee to make decisions, solve problems and improve service

quality, and overall business practises (Business Dictionary, 2017). The encouragement through empowerment usually creates job satisfaction and high level of service quality. Employee empowerment brings about better recognition of employees. Authority is given to employees to be responsible of any challenge they encounter in their allocated tasks while performing their duties, thus contributing to the greater achievement of the organisational goals (Clutterbuck & Kernaghan, 1994).

Kinds of organisational empowerment

a) Reward Empowerment

This refers to the benefits employees receive after they have taken risks and performed well and this can be in form of promotions, appreciation and remunerations. The empowerment happens as an after effect of good performance by the employees (Armstrong, 2012).

b) Training

One of the important aspects of an organisational role is the training of its employees with goal of their empowerment. The objective of training is to prepare employees to do their own particular critical thinking; employees cannot be empowered until they get information and tools required to administer their task responsibly. It is the responsibility of the organisation to ensure that employees are trained, thus enhancing growth and development. The outcomes of training and development of employees will be effective and beneficial to the organisation. Employees who obtain skills and knowledge through training contribute to efficient performance of their duties (Elnaga & Imran, 2014). The necessary technical and interactive skills training given to employees will improve their competency and ensure that they deliver good service quality to their customers.

c) Leadership approach

Leadership has the capacity to influence the behaviour of employees in realisation of the objectives and goals of an organisation (Igbaekemen, 2014). Yonssef and Luthas (2012), state that if leadership is approached positively it increase strength and capabilities and company's growth and development. There is a need for direction for people much more than support for them to be empowered (Blanchard, Carlos and Randolph, 1999). Managers are vital in the successful adaption of empowerment practises within the organisation and it will be the managers who are challenged to change their old outdated practises of control and discipline (Frerk, 2013).

d) Quality of work

It is good that the organisation give the employee an opportunity to participate in the well-being of the organisation, the feeling that their contribution and effort is recognised in the organisation pays a vital role in their development. If employees are independent and flexible to perform their duties, they feel empowered to deliver high. Employee empowerment takes personal pride in their work and responsibility for doing good job and deliver good service to the customers.

e) Teamwork

Empowered employees that are treated as asset of the organisation gain confident and become effective and are willing to share information with others in an honest and open manner. The impact of this promotes teamwork and employee involvement in support of the organisation's goals. Team spirit among employees improves customer satisfaction. Teamwork environment improves performance of employees and helps to eliminate the challenges and obstacles that will affect their progress. According to Clutterbuck *et al* (1994), involvement of employees on the progress and effectiveness of the organisation is of high importance.

SOUTH AFRICAN SENARIO

A significant attention had been received in the subject of employee empowerment on service quality within South Africa's sectors (Pandle, 2006; Winnaar, 2006; Molefe, Stander and Rothman; 2009; Nilsson, 2010; van Schalkwyk et al., 2010; Mafinu and Pooe, 2013; Bester et al., 2015; Zungu and Mason, 2017). This section highlights the concept of employee empowerment on the service quality in selected sector within South Africa. The banking industry are presently promoting customer satisfaction and loyalty through better service quality, if the quality service is performed more effectively it builds long term relationship with customers (Zungu and Mason, 2017). Consumers prefer specific banks because of certain services offered and performance of the service provided. The service offered by bank improves and maintain relationship if it is offered effectively and efficiently. The banking industry has changed a lot; this is because of the change in technology and to meet the customer expectations and to compete effectively with the rivals. Banks has increased their commitment in service quality to excel in customer satisfaction. The banks have introduced a variety of choices for consumers to access the bank services and customers are not ready to compromise their needs and expectations for the banks (Maiyaki, 2011). The study by Ramjee, (2007) showed that some of the key ways of empowering the banking staff in South Africa are the share scheme, Reward and recognition. The motivating factors contributing to better quality of service to the bank customers by the bank employees are self-development of employees, efficient work processes, career progression and client interaction. However, the result of the findings by Zungu and Mason (2017) showed that South African banking customers are generally satisfied with their banks based on their relatively high level of loyalty towards their banks; but not 'delighted'. It appears the banks are offering similar level of service, with none doing much to delight their customers and remain exceptional. Mafini and Pooe (2013) investigated the impact of employee satisfaction on organisational performance in the South African government department. The authours adopted five employee satisfaction factors, namely teamwork, working conditions, creativity, ability utilisation, and autonomy.

The study revealed that there was a good relationship between the factors and organisation performance with teamwork having the strongest impact on the overall performance. The optimisation and expedition of the employee satisfaction is seen as an incentive in enhancing the organisational performance. Whereas, organisational satisfaction diminishes with employees dissatisfaction. In the South African public organizations, Nilsson (2010) holds the view that in most public sector disciplines, under performance is difficult to overcome. Therefore, most of the government institutions continue to receive constant criticism for poor corruption, service delivery, poor corporate governance, financial mismanagement and bureaucracy (Van der Heijden & Mlandi, 2005). The demands of the populace of the country is so high that employee empowerment in the public sector do not necessarily translate to satisfaction thus it is not appreciated. Certain malpractices showed by the government employees in the past such as low institutional capacities, limited stakeholder participation, high levels of corruption lack of demographic representation, poor accountability, conflicting labor relations and high levels of informality constitutes to poor performance in the public sector (Putu et al., 2007). Van Schalkwk et al., (2010) demonstrated that Leadership empowerment behaviour contributed significantly to a positive employee engagement and low turnover intention.

This results to Employees maintaining high mental resilience and energy levels, thus willing to put in efforts and pride and persevere in challenging situations. Stander and Rothmann (2009) observed similar view, on psychological empowerment in selected organization in South Africa. However, employee empowerment can be improved by, non-biased promotions and delegations of duties to lower levels of employees (Chinomona et al., 2017).

CONCLUSION

Employee empowerment in an organisation has a pivotal role to play in terms of ensuring organisation performance and customer loyalty and perception improvement, through enhanced service quality. The paper reviewed several key concepts of service quality, employee empowerment and approaches taken by organisations in empowering its employees. The review of studies on employee empowerment in South Africa was discussed. To conclude, the paper observed that, in almost all the sectors investigated, a good relationship between employee empowerment, service

quality, organisation performance and satisfaction level exist. Organisational performance and customers' satisfaction is strongly influenced by the level service quality resulting from the contribution of the employee empowerment. However, in the public sector, this case is not always the same; government institutions continue to receive criticism relentlessly for poor corruption, service delivery, poor corporate governance, financial mismanagement and bureaucracy, irrespective of the level of employee empowerment and service quality rendered by the government employee.

REFERENCES

- Armstrong, M. (2012). *Armstrong's handbook of human resource management practice*. 12th ed. London: Grafton.
- Bartram, T. & Casimir, G. (2006). The relationship between leadership and follower in-role performance and satisfaction with the leader. *Leadership & Organization Development Journal*, 28(1), 4 – 19.
- Bester, J., Stander, M.W., & Van Zyl, L.E. (2015). Leadership empowering behaviour, psychological empowerment, organisational citizenship behaviours and turnover intention in a manufacturing division. *South African Journal of Industrial Psychology*, 41 (1), 1 – 14.
- Blanchard, K., Carlos, J.P. & Randolph, A. (1999). *The three keys to empowerment*, Berrett-Koehler, San Francisco.
- Chinomona, E., Popoola, B.A., & Imuezerua, E. (2017). The Influence of Employee Empowerment, Ethical Climate, Organisational Support and Top Management Commitment on Employee Job Satisfaction. A Case of Companies in the Gauteng Province of South Africa, Vaal University of Technology, South Africa. *The Journal of Applied Business Research*, 33(1), 27 – 42.
- Clutterbuck, D., & Kernaghan, S. (1994). *The power of empowerment*, BCA/Kogan.
- Cudjoe, A.G., Anmin, P.A., & Nyanyofio, J. G. (2015). Service Quality and Customer Satisfaction in the Ghanaian Banking Industry (A Case of Ghana Commercial Bank). *European Journal of Business and Management*, 7, 123 – 140.
- Elnaga, A.A. & Imran, A. (2014). The Impact of Employee Empowerment on Job Satisfaction Theoretical Study. *American Journal of Research Communication*, 2(1), 13 – 26.
- Empowerment*. BusinessDictionary.com. WebFinance, Inc.
<http://www.businessdictionary.com/definition/empowerment.html> (accessed: May 21, 2017).
- Ferguson, J., Ashcroft, D., & Hassell, K. (2011). Qualitative insights into job satisfaction and dissatisfaction with management among community and hospital pharmacists. *Research in Social and Administrative Pharmacy*, 7(3), 306–316
- Frerk, J. (2013). *The implementation of employee empowerment practises and organisational effectiveness*, Masters Thesis, University of Johannesburg.
- Ramjee, M. (2007). *An Investigation into the Impact of Training and Leadership Programmes on Employee Empowerment*, Masters Thesis, Nelson Mandela Metropolitan University, Business School.
- Gronroos, C. (2007). *Service Management and Marketing: Customer Management in Service Competition*, 3rd Edition, Wiley and Sons
- Hedge, J. W., & Borman, W. C. (2012). *Work and aging*. In S. W. J. Koslowski (Ed.), *The Oxford handbook of organizational psychology*, 2, 1245 – 1283.

- Igbaekemen, G. O. (2014). Impact of Leadership Style on Organisation Performance: A Strategic Literature Review, *Public Policy and Administration Research*, 4 (9), 126 – 135.
- Looy, B.V., Gemmel, P., & Van Dierdonck, R. (2003). *Service Management: An Integrated Approach*. (2nd Ed.). Mc-Graw hill, Singapore.
- Mafini, C., & Poole, D.R.I. (2013). The relationship between employee satisfaction and organisational performance : Evidence from a South African government department. *South African Journal of Industrial Psychology*, 39(1), 1 – 9.
- Maiyaki, A.A. (2011). Factors determining Bank's selection and preference in Nigerian retail banking, *International Journal of Business and Management*, 6 (1), 253 – 255.
- Menon, S.T. (2001). Employee empowerment: An integrative psychological approach. *Applied Psychology: An International Review*, 50, 153 – 180.
- Mayfield, J., & Mayfield, M. (2002). Leader communication strategies : Critical paths to improving employee commitment. *American Business Review*, 6, 41–49.
- Minnaar, F. (2006). Integrated performance management : The evolving South African management model. *Journal of Public Administration*, 41(21), 177–190.
- Nilsson, J. (2010). What's the problem ? Local officials' conceptions of weaknesses in their municipalities' crisis management capabilities. *Journal of Contingencies and Crisis Management*, 18(2), 83–95.
- Olaleke, O.O. (2010). Assessing the relationship between service quality and customer satisfaction; evidence from Nigerian banking industry, *Global Journal of Management and Business Research*, 10 (3), 2 – 5.
- Pandle, N.L. (2006). *An Investigation into Employee Empowerment Strategies for Small, Medium and Micro Enterprises (SMME'S)*, Masters Thesis, Nelson Mandela Metropolitan University.
- Parasuraman, A., Zeithaml, V.A. and Berry, L.L. (1985). SERVQUAL: a multi-item scale for measuring consumer perceptions of the service, *Journal of Retailing*, 49, 41 – 50.
- Putu, N.I., Mimba, S.H., Van-Heden, J., & Tillema, S. (2007). Public sector performance measurement in developing countries : A literature review and research agenda. *Journal of Accounting and Organisational Change*, 3(3), 16–17.
- Qasim. S., Cheema. F.E. & Syed. N.A. (2013). Exploring Factors Affecting Employees' Job Satisfaction at Work. *Journal of Management and Social Sciences*, 8(1), 31 – 39.
- Robinson, R. (1997). Loosening the reins without losing control. *Empowerment in Organisations*, 5(2), 76 – 81.
- Salazar, J., Pfaffenberg, C., & Salazar, L. (2006). “Locus of Control vs. Employee Empowerment and the Relationship with Hotel Managers' Job Satisfaction”. *Journal of Human Resources in Hospitality & Tourism*, 5(1), 1 – 16.
- Sarwar. A. & Khalid A. (2011). Impact of Employee Empowerment on Employee's Job Satisfaction and Commitment with the Organization. *Interdisciplinary journal of contemporary research in business*. 3(2), 664 – 683.
- Spreitzer, G.M. (1995). Psychological empowerment in the workplace: Dimensions, measurement and validation, *Academy of Management Journal*, 38, 1442 - 1465.

Stander, M.W., & Rothmann, S. (2009). Psychological empowerment of employees in selected organisations in South Africa. *South African Journal of Industrial Psychology*, 35(1), 1-8.

Sureshchandar, G.S., Rajendran, C., & Anantharaman, R.N. (2002). "The relationship between service quality and customer satisfaction – a factor specific approach", *Journal of Services Marketing*, 16 (4), 363 – 379.

Van der Heijden, T., & Mlandi, M. (2005). Organisational success and failure in the public sector. *Journal of Public Administration*, 6(4), 20–22.

Van Schalkwyk, S., Du Toit, D.H., Bothma, A.S., & Rothmann, S. (2010). Job insecurity, leadership empowerment behaviour, employee engagement and intention to leave in a petrochemical laboratory. *South African Journal of Human Resource Management*, 8(1), 1- 7.

Youssef, C.M., & Luthans, F. (2012). Positive global leadership. *Journal of World Business*, 47(4), 539–547.

Zeithaml, V. A., Bitner, M. J. and Gremler, D. D. 2006. *Service marketing customer focus across the firm*. 4th Ed. New York: McGraw-Hill.

Zungu, N. P., & Mason, R.B. (2017). Young clients' attitudes to service quality at retail banks in a developing country, *Banks and Bank Systems*, 12 (1), 44 – 53.

THE ROLE OF THE TAX SYSTEM IN THE DEVELOPMENT OF OIL AND GAS COMPLEX

Sona Sumbatyan
The State University of Management, Russia

ABSTRACT

Oil and gas complex is the foundation of Energy of the Russian Federation and the most important economic complex. Fuel and energy resources, production and scientific-technical potential of the oil and gas industry - is the most important asset of the country. And major sectors of the economy are provided by oil and gas complex. The article "The role of the tax system in the development of oil and gas" is devoted to the presentation of the basic ideas of the system of taxation of oil and gas complex taxation system. It is one of the sources of tax revenue of the state. In this article the impact of the tax system on the efficient allocation and use of resources: the field must develop the most efficient owners who will use modern technology and, ultimately, reduce costs and extract the maximum amount of oil. The tax system should be flexible and instantly react to price fluctuations, as well as the tax mechanism must take into account the advantages of the natural conditions, stages of operation of oil companies.

Keywords: The tax system, development, oil and gas complex.

INTRODUCTION

Russia is the powerful oil and gas country with the world's largest reserve of fuel and energy resources. About half of the incomes of the federal budget, exports and foreign exchange earnings of the country is provided by oil and gas complex. There is a need for radical changes in the oil and gas complex.

The main economic tasks of the oil and gas complex development are effective export activities; using of new capacities in the oil and gas complex; Replacement of physically worn out and obsolete equipment, oil pipelines; development of new fields and carrying out geological explorations of sufficient volume.

THE RELEVANCE OF RESEARCH

The oil and gas complex are the basis of the energy sector of the Russian Federation and the most important national economic complex. The oil and gas complex are one of the sources of tax revenues of the country. Russia currently owns one of the world's largest reserves of fuel and energy resources.

Fuel and energy resources, production, scientific and technical potential of the oil and gas complex are the most important asset of the country. And the main branches of the national economy are provided by the oil and gas complexes. It is only necessary to use effectively the country's huge resources.

In 2013, Russia regained its leading position and won first place in oil extraction in the world. As of 2014, in the world, according to proved oil reserves, Russia is located on the sixth place - 14.1 billion tons, the total world oil reserves amount to 239.8 billion tons. However, in terms of oil extraction, Russia ranks second in the world - 534.1 million tons per year, behind Saudi Arabia - 543.4 million tons per year (Statistical Review of World Energy 2015). More than 2,000 oil and gas fields have been discovered on the territory of Russia. Most of the explored oil reserves are concentrated in Western Siberia and the territory of the Urals Federal District.

Effective operation of the oil and gas complex creates conditions for the growth and sustainable development of the Russian economy. In the conditions of tough competition, both at the domestic and world level, the country's oil companies must build their development strategy.

PROBLEM STATEMENT

With the positive results achieved in recent years in the oil industry, in Russia the domestic market of petroleum products is underdeveloped. The development of a system of trunk oil pipelines and sea terminals to supply oil to the main world markets is unsatisfactory, which disturbs the effective use of the geographic factor - Russia's connection with all major oil markets: Europe, USA and Asia-Pacific region. Eastern Siberia and the Far East are considered as the main oil production areas, which development is of special importance for Russia's socio-economic and strategic interests in the Asia-Pacific region. It is very important to develop oil and gas production centers on the shelf of Sakhalin Island, Barents Sea, Baltic and Caspian Seas. For the development of the industry, needs companies that are financially stable, cost-effective, use the latest technologies, are environmentally safe and have highly qualified personnel. After the transition to market relations were lost socio-economic institutions, branch communications of enterprises, branch scientific centers, which developed scientific and technical innovations. In recent years, the oil and gas complex has undergone serious structural changes that have provided some stability and stability in the development of a number of industries. However, lately there has been a loss of unity in the development of companies, inhibition of scientific and technological development, a reduction in the innovative activity of enterprise subsystems, and the liquidation of departments of research and development works. At this time, for enterprises, it is important only to obtain the maximum current profit, the long-term development is pushed to the background.

At the present time, the main goal of oil companies is to obtain current excess profits, based on favorable price conditions on world hydrocarbon raw materials markets. Priority for oil companies is the extraction-export formula. Consequently, resources are not invested in fixed assets, in processing, in full development of fields. Oil companies are predatory to the fields, "removing the cream" only from high-yield fields. Inconsistencies and contradictions are obvious between macroeconomic and microeconomic interests; that means, the interests of the national economy with the interests of economic entities.

Especially obviously these contradictions appear in the management of scientific and technological development of production. In the oil and gas complex equipment, fixed assets are badly worn out, and oil companies do not seek to update them, preferring current profits, by exploiting the old equipment, also causing great harm to the atmosphere. It'll lead to grave consequences.

Macroeconomic interests are: the introduction of new technology, productivity growth, lower costs, protection of atmosphere, raising the level of national security, etc. From the point of view of microeconomic interests, it is advantageous to raise prices for products, minimize capital expenditure and increase profits.

After the transition to market relations the system of taxation in the oil industry of Russia constantly suffered significant changes. At present, one of the forms of state regulation of the oil and gas complex is the tax policy. The current tax policy has shown that it has significant limitations, namely, it does not provide for differential taxation.

The main taxes of the oil industry and the oil and gas incomes of the federal budget include the incomes of the federal budget from the payment of a tax on the extraction of minerals in the form of hydrocarbon raw materials (oil, natural gas from all types of hydrocarbon fields, gas condensate from all types of hydrocarbon fields); export customs duties on crude oil, natural gas and goods produced from oil. These incomes are used to finance the Reserve fund.

The incomes of the federal budget in 2015 amounted to 13,659.2 billion rubles (16.9% of GDP), including oil and gas incomes - 5,862.7 billion rubles, non-oil - 7,796.6 billion rubles. It should be noted that in the total amount of federal budget incomes in 2015, oil and gas revenues amounted to 42.9% (Accounts Chamber of the Russian Federation 2015).

Today, the tax system of the Russian Federation contains a huge number of fees - both from individuals and enterprises. One of the newest payments is a tax on the extraction of minerals. It was put into effect in early January 2002, when was adopted the 26th chapter of the Tax Code of Russia. With the adoption of the relevant draft law, almost immediately, were cancelled deductions for subsoil use and excises tax on oil.

In accordance with the current legislation, payers of this fee are sole proprietor and enterprises, which use the earth's bowels for the extraction of a particular resource in their activities. Legislation reads that mineral resources can be used for the following needs: geological study of regional and global scale. These researches include the evaluation and searching of minerals, as well as many other procedures not related to the extraction of minerals; collection of paleontological, mineralogical, as well as many other substances of value to collectors; directly exploration and extraction of profitable substances; construction and further operation of facilities not related to the extraction of resources; modernization of geopolitical facilities, which have aesthetic, cultural and sanitary-health value.

Only one item from the above falls under the taxation system – extraction of useful minerals.

Now the extraction of such minerals as: brown and bituminous coal, anthracite, slates, hydrocarbon raw materials (natural gas, gas condensate, oil), peat, natural origin diamonds, multicomponent ores, deposits of non-ferrous and ferrous metals, non-metallic mining and chemical raw materials, pure sodium chloride and natural salt, groundwater, which contains minerals and radioactive materials are subjects to taxation.

Today, Russian law works with several models of calculating the tax on the extraction of minerals. All models differ in character of the tax rates and in the procedure for determining the corresponding base. The imperfection of the tax system, subsoil legislations is a barrier to the improvement the situation in the oil and gas complex. It should be noted that the taxation system in the Russian Federation is not focused on increasing the extraction efficiency, it is not flexible. The tax system of the oil sector currently does not support profitability growth of production and increase the investment resources of companies, which, with a decrease in the price of oil, may have a negative impact to the development of companies and the industry.

As the main taxes in the oil industry depend on world oil prices, increasing the share of the oil and gas complex in tax incomes leads to an increase in the dependence of the budget on the world market. The operating tax system to accumulate of a huge part of the unaccounted rental income of oilmen. The tax system hold back the development of production in the domestic market and stimulates the export of capital abroad. It should be noted the long payback periods of additional investments in innovative processes in oil production. With a reduction of net cost and a significant amount of capital expenditure, it is not surprising that oil companies desire to increase prices and export crude oil.

CONCLUSION

So, today, there is no effective system for withdrawing oil companies' super profits, namely, oil taxes do not provide for a mechanism for accounting differential rent for various production conditions in the fields. Therefore, small and medium-sized oil-producing companies, which do not have the opportunity to conduct selective production are suffering. However, this negatively affects both the industry and the state, which is the owner of the subsoil and should be interested in the most complete and effective use of non-renewable natural resources. And for the optimal use of rent, it is needed a different tax system.

Significant importance for the state gets promotion to search and exploration of new fields, and solving social problems, including maintenance of employment at the low-profit fields. Therefore, in this case, it is necessary not only exemption from special taxes, but also to provide additional benefits.

The tax system should facilitate efficient allocation and use of resources: the fields should be developed by the most efficient owners who will use modern technologies and, finely, reduce costs and extract the maximum amount of oil. The tax system should be flexible and instantly respond fluctuations in prices. The withdrawal mechanisms should be diverse and reflect the specifics of each particular field. The tax mechanism should take into account the advantages of natural conditions, the stages of oil companies' functioning, therefore the charging of rent payments for superprofits, will be a push for the effective development of the oil and gas complex. It should also be noted that a significant lack of the mineral extraction tax is its dependence on world oil prices. The larger the share of exports, the less a company pays a mineral extraction tax in relation to export earnings.

REFERENCES

Accounts Chamber of the Russian Federation (2015). Conclusion of the Accounts Chamber of the Russian Federation on the report on the execution of the federal budget for 2015. Source: <http://www.budgetrf.ru/Publications/Schpalata/Zakluchenia/pdf9/2015.pdf>

Statistical Review of World Energy 2015. Source: <http://www.bp.com/content/dam/bp/pdf/speeches/2015/statistical-review-of-world-energy-2015-bob-dudley-speech.pdf>

VALIDATING A GREEN PURCHASE BEHAVIOUR MODEL AMONGST AFRICAN GENERATION Y STUDENTS

C. Synodinos
North-West University, South Africa

ABSTRACT

Environmental preservation, a prevalent topic in today's day and age, is at the forefront of rewriting business plans and strategies to accommodate environmentally conscious consumers. This paper aimed to validate a green purchase behaviour model of African Generation Y students in the South African context. The data analysis methods included: exploratory factor analysis, descriptive measures, correlation analysis, structural equation modelling and independent samples t-tests. The findings indicated that the green purchase behaviour measurement model is a two-factor structure comprising environmental intention and green purchase behaviour. The measurement model exhibited acceptable fit indices, construct validity and reliability. Furthermore, there were no differences in gender regarding the constructs in the green purchase behaviour model.

Keywords: Environmental intentions, green purchase behaviour, Generation Y, South Africa.

INTRODUCTION

Environmental preservation, an ever present and rapidly escalating topic in today's era has gained recognition from both governments and business corporations alike (Haytko & Matulich, 2008, p.2). This is echoed by Peattie and Charter (2003, p.736) who emphasise that heightened environmental awareness has created new market opportunities for organisations in terms of niche marketing, differentiation, cost advantages and customer segmentation. This environmental awareness is a direct result from increased media coverage, environmental campaigns and basic environmental education and awareness particularly in school environments where environmental campaigns are particularly targeted at the youth (Chekima, Wafa, Igau, Chekima & Sondoh, 2016, p.3437; Ali & Ahmed, 2012, p.85). Consequently, the environmental trend wave has gained fierce momentum reforming consumers purchasing behaviours and the way they think about their product consumption patterns (Yadav & Pathak, 2016, p.732).

Consumers have increasingly pressed the issue of environmental conservation and expressed their concerns in their purchasing behaviour (Laroche, Bergeron & Barbaro-Forleo, 2001, p.503). Pro-environmental purchases are prominent in the market today, so much so that consumers are choosing environmentally friendly products over traditional products in certain product categories (Dangelico & Pujari, 2010, p.471; Ottman, Strafford & Hartman, 2006, p.26). Evidence of this pro-environmental behaviour was found in many studies with results being replicated on numerous occasions. The studies concluded that not only were consumers purchasing environmental products but they were even prepared to pay the increased price often associated with environmentally friendly products (Rahbar & Wahid, 2011, p.73; Sodhi, 2011, p.177; Gupta & Ogden, 2009, p.376; Kalafatis, Pollard, East & Tsogas, 1999, p.442).

The environmental movement has evolved more so in developed countries than in developing countries (Yadav & Pathak, 2016, p.732). South Africa, a developing nation, is the biggest contributor of greenhouse gases in Africa and ranks 14th in the world, contributing even more greenhouse gases than some developed nations such as the United Kingdom (Coleman, 2012, p.184). Thus, it is imperative to delineate possible green ambassadors and green consumers in the Generation Y cohort in South Africa.

LITERATURE REVIEW

Green purchase intention

A consumer's purchase intention can be defined as the extent to which the individual is willing to perform a certain or specific behaviour (Niaura, 2013, p.74). This intention is believed to serve as a function of eventual purchase behaviour (Polonsky, Vocino, Grau, Garma & Ferdous, 2012, p.240). As traditional purchase intentions are closely related to environmental intention, it may be inferred that environmental intentions is then a function of purchase behaviour, more specifically environmental purchase behaviour (Abdul-Muhmin, 2007, p.237). Looking through the environmentalist's standpoint, an individual's environmental intention is a predetermined plan to act on an environmentally friendly behaviour. Additionally, environmental intention serves as a presupposition to act in pro-environmental activities and increases the likelihood of purchasing environmentally friendly products (Chen & Chang, 2012:20; Abdul-Muhmin, 2007, p.237). Prior academic literature has identified many different components (i.e. demographics, psychographic variables and attitudes) as attributing factors towards motivating environmental behaviour, however, majority of academics are in consensus that environmental purchase intentions are highly correlated with environmental behaviour (Lee, 2009, p.88; Mostafa, 2007, p.450).

Green purchase behaviour

Today's consumer have realised that their purchasing decisions has the ability to change organisational business strategies and as a result they have the power to directly influence ecological issues at present in a positive manner (Kumar, Kumar, Rahman, Yadav & Goyal, 2011, p.62.3; Laroche *et al.*, 2001, p.503). These environmental concerns have resulted in consumers opting for environmentally friendly products over traditional products (Do Paco & Raposo, 2009, p.365; Mostafa, 2007, p.445-446). Consumers who engage in environmentally friendly activities have changed their purchasing behaviours to products that are biodegradable, recyclable and eco-friendly (Kumar *et al.*, 2011, p.62.3; Laroche *et al.*, 2001, p.503). Additionally these consumers are paying premium prices in efforts to preserve the environment (Rahbar & Wahid, 2011, p.73; Sodhi, 2011, p.177-178; Kalafatis *et al.*, 1999, p.442).

Green marketing has not always enjoyed great success and understanding environmental behaviours of consumers is no easy task for marketers (Haytko & Matulich, 2008, p.2). There is evidence suggesting that consumers have developed strong feelings towards environmental conservation (Chang, 2011, p.19; Rahbar & Wahid, 2011, p.74; Do Paco & Raposo, 2009, p.376; Mostafa, 2007, p.450-451; Peattie, 2001, p.137), yet their purchasing actions suggest the contrary. A few theories as to why consumers have ambivalent feelings towards environmental products include: "social over-reporting" (Peattie, 2001, p.137), lack of environmental knowledge (Kanchanapibul, Lacka, Wang & Chan, 2014, p.19) and fear of inferior product quality and increased costs (Chang, 2011, p.19; Do Paco & Raposo, 2007, p.376). Therefore, to encourage green purchasing behaviour academics believe that an understanding of green consumers' purchasing behaviours is paramount to successful green product adoption (Levine & Strube, 2012, p.322; Charter, 2003, p.737; Peattie, 2001, p.137).

Generation Y

In 2016, the Generation Y cohort made up approximately 38 percent of South Africa's population. The African portion constituted 84 percent of the Generation Y cohort (Statistics South Africa, 2016). Classified as being born between 1986 and 2005, Generation Y individuals are significant players in the future of environmental conservation (Eastman & Liu, 2012, p.94; Markert, 2004, p.21). Opinionated, trend setters and educated at tertiary institutions, African Generation Y individuals have the capacity to potentially earn a higher than average income and subsequently possess greater amounts of disposable income (Bevan-Dye & Surujlal, 2011, p.49). Being brought up in an eco-conscious lifestyle, Generation Y individuals display major positive attitudes and behaviour towards environmental sustainability (Rogers, 2013). Evidence of this behaviour has been found by various academics (Barton, Fromm & Egan, 2012; Smith, 2012, p.87). The authors explain that Generation Y consumers may be inclined to support environmentally friendly organisations, they also tend to assist local communities and actively

participate in campaigns that serve to protect the environment. Positive thinking streams and pro-environmental agenda's such as these will significantly aid towards the future of environmentalism (Lee, 2009, p.87). Therefore, it is imperative to gather an understanding of the youth's environmental intentions and consequently their environmental behaviours as these individuals are the countries future workers, consumers, innovators and leaders (Kanchanapibul *et al.*, 2014, p.528).

PROBLEM INVESTIGATED

The purpose of this study sought to validate a green purchasing behaviour model amongst African Generation Y university students in the South African context. Furthermore, this study investigated the possibility of discrepancies with regards to gender towards environmental intentions, perceived environmental price and quality of green products and green purchase behaviour. Finally, the study forms part of a larger study concerning the mediating effect perceived price and quality of green products have towards green purchase behaviour. Hence, the research questions included are: Is the green purchase behaviour model a two-factor structure? Do female and male African Generation Y students differ in terms of environmental purchase intention, perceived price and quality of green products and green purchase behaviour? Did the proposed green purchase behaviour measurement model comply with all the requirements to conduct a structural model?

RESEARCH METHODOLOGY

Research design and methods

A descriptive research design was the adopted approach for this study. The defined target population for this study consisted of African Generation Y university students aged between 18 and 24 years, currently registered at a public higher education institution (HEI) in South Africa. The sampling frame consisted of the 26 publicly registered HEIs in South Africa. The sampling frame was reduced to four HEI campuses located within the Gauteng province. The chosen HEIs comprised one comprehensive university, one university of technology and the remaining two consisted of traditional universities. Utilising non-probability convenience sampling and mall-intercept techniques, fieldworkers administered 500 questionnaires across the four HEIs to willing participants. Of the 500 questionnaires that were distributed, 422 were returned and 332 questionnaires were completed and viable for data capturing.

Measurement instrument

The data were collected using a self-administered survey questionnaire, wherein a demographic section and a section containing validated scales from prior published research was utilised to collect the necessary data. To measure environmental purchase intentions (three items), perceived price (one item), perceived quality (one item) and environmental purchase behaviours (four items) of African Generation Y students, scales from Mostafa (2007, p.472-473); D'Souza, Taghian and Khosla (2007, p.73) and Lee (2008, p.580) were used respectively. All scaled responses were coded using a six-point Likert scale for the purpose of excluding the redundant neutral response (Pallant, 2010, p.10). The scale ranged from strongly disagree (1) to strongly agree (6). The proposed questionnaire was presented to the Ethics Committee of the North-West University (Vaal Triangle Campus). The ethics committee screened the questionnaire and deemed the undertaking to be a low/no risk study and awarded the questionnaire the ethical clearance number of: Econit-Econ-2014-007.

Data analysis

The data were analysed using IBM's Statistical Package for Social Sciences (SPSS) and Analysis of Moment Structures (AMOS), Version 24 programs. Various analysis were undertaken including frequencies, exploratory factor analysis, Pearson's Product-Moment correlation analysis, structural equation modelling using the maximum likelihood method, descriptive statistics and an independent samples t-test. Various fit indices were computed to assess model fit and included the root mean square approximation (RMSEA), the standardised root mean residual (SRMR), the goodness-of-fit (GFI), the normed fit index (NFI), the incremental fit index (IFI), the Tucker Lewis

Index (TLI) and the comparative fit index (CFI). Good model fit is generally associated with GFI, NFI, IFI, TLI and CFI values of ≥ 0.95 , a RMSEA of $q < 0.80$ and a SRMR value of $q \leq 0.05$ (Malhotra, 2010, p.732-733). The statistical significance level was set at $p < 0.01$.

RESULTS

Sample description

The 322 viable questionnaires represented a 64 percent response rate, whereby 53 percent represented female participants and 47 percent were male participants. The sample included each of South Africa's nine provinces and represented participants of every age category specified for this study. The two traditional universities yielded the highest amount of participants at 49 percent of the sample, whilst the University of Technology made up 32 percent and the remaining 19 percent belonged to the comprehensive university. Table 1 below outlines a description of the sample used in this study.

Table 1: Sample description

Gender	Percent (%)	Province	Percent (%)	Age	Percent (%)	Institution	Percent (%)
Female	53	Gauteng	50.6	18	13	Traditional	49
Male	47	Limpopo	17.8	19	17.2	Technology	32
		Mpumalanga	7.5	20	18.7	Comprehensive	19
		North-West	6.9	21	23.4		
		KwaZulu-Natal	6.3	22	14.8		
		Free State	5.1	23	9		
		Eastern Cape	4.5	24	3.9		
		Western Cape	0.6				
		Northern Cape	0.3				

The proceeding section involves the factor analysis conducted for the study.

Factor Analysis

To ensure the data was free from any cross-loading items an exploratory factor analysis was conducted. The results yielded a Kaiser-Meyer-Olkin (KMO) value of 0.875 and a significant Bartlett's test of sphericity (chi square = 1032.364, 21 dfs, $p < 0.000$), indicating adequate factorability of the data (Field, 2009, p.659-660). Following this principle component analysis, utilising promax rotation, was performed on the data set. Additionally, the Cronbach alphas of the constructs were computed to assess the internal consistency reliability of the extracted constructs. The results are depicted in Table 2 below:

Table 2: Rotated factors

Items	Factors		Communalities
	1	2	
Item 1	0.886		0.726
Item 2	0.915		0.769
Item 3	0.801		0.767
Item 6		0.778	0.681
Item 7		0.949	0.689
Item 8		0.697	0.689
Item 9		0.646	0.605
Percentage of variance	56.192	14.160	
Cronbach alpha values	0.841	0.817	

Owing to perceived price and perceived quality being one itemed scales they were excluded from the factor analysis. Consequently, two factors were extracted in line with the literature and combined explained 70.35 percent of the variance. Each of the items displayed loadings above 0.5, with majority exceeding 0.70 indicating practically significant loadings (Hair, Black, Babin & Anderson, 2010, p.117). Furthermore, all communalities exceeded 0.50, which is indicative of each item's variance being accounted for by the factor solution (Hair, *et al.*, 2010, p.136). Finally, Cronbach alpha values of 0.841 and 0.817 indicate adequate internal consistency reliability (Malhotra, 2010, p. 319; Field, 2009, p.674).

To assess if there was any multicollinearity present between the two extracted factors, collinearity diagnostics was run on the data set where the case number was set as a dummy dependent variable. The test revealed tolerance of 0.629, which is above the cut-off point of 0.60. Additionally, the average variance inflation factor totalled to 1.590, which is below the cut-off level of 10. These results indicate no serious multicollinearity concerns (Pallant, 2010, p.158).

Correlation Analysis

A Pearson product-moment coefficient correlation matrix was constructed to assert nomological validity of the proposed model. Table 3 depicts the correlation matrix.

Table 3: Correlation matrix

N = 329	1	2	3	4
Perceived environmental intention	1			
Perceived environmental price	0.557**	1		
Perceived environmental quality	0.556**	0.505**	1	
Green purchase behaviour	0.609**	0.650**	0.559**	1

**Correlation is significant at the 0.01 level (2-tailed)

As is evident from Table 3, each pair of latent factors represents a statistically significant correlation coefficient at the p 0.01 level. These findings assert nomological validity for the proposed green purchase behaviour model (Malhotra, 2010, p.321). With no evidence of multicollinearity and nomological validity established it was presumed safe to conduct structural equation modelling.

Measurement model specification

A two-factor measurement model was specified; the latent factors comprised perceived environmental purchase intention (three indicators) and green purchase behaviour (four indicators). The first loading of each of the two factors were fixed at 1.0 in order to identify the model. This lead to 28 distinct sample moments with 15 parameters to be estimated. As such, 13 degrees of freedom (df) arose based on an over-identified model and a significant chi-square value of 23.587 with a probability level equal to 0.035. Owing to the fact that the measurement model only included two latent factors, each with three and four indicators respectively (Hair *et al.*, 2010, p.662), the sample size of 332 participants was deemed sufficient for the use of structural equation modelling.

The measurement model was scrutinised for any irregular estimates such as standardised loading estimates above 1.0 or below -1.0, as well as any negative error variances (Kline, 2011, p.158). Regarding the reliability and construct validity of the model, composite reliability (CR), correlation coefficients and average variance extracted measures were calculated. The results are depicted in Table 4 below:

Table 4: Estimates for measurement model

Latent factors	Standardised loading estimates	Error variance estimates	Composite reliability	Average variance extracted	√Average variance extracted
Perceived environmental intention	0.746	0.556	0.75	0.50	0.71
	0.783	0.613			
	0.865	0.747			
Green purchase behaviour	0.766	0.586	0.80	0.50	0.71
	0.613	0.376			
	0.798	0.637			
	0.725	0.526			
Correlations	F1Intention↔F2Behaviour: 0.754				

Table 4 displays no problematic estimates for the measurement model, and depicts statistically significant relationships ($p < 0.01$) between each indicator and each of their respective latent factors. Both latent factors exceeded the recommended cut off threshold for composite reliability of 0.70 indicating convergent validity (Malhotra, 2010, p.734). In addition, all indicators displayed acceptable standardised estimates above 0.50 and AVE values above 0.50 (Hair *et al.*, 2010, p.688, 709). Following the reliability and validity confirmation, the next step was to assess the model fit indices. Known to be highly susceptible to sample size, a significant chi-square was computed. However, the remaining fit indices proved to be indicative of good model fit. The indices included the following values: RMSEA= 0.50, SRMR = 0.029, GFI = 0.980 NFI = 0.977, IFI = 0.990, TLI = 0.983, CFI = 0.990 and GFI = 0.980. These results suggest that the green purchase behaviour model is a two-factor structure comprising perceived environmental intentions and green purchase behaviour.

Independent samples t-test

To assert if any difference between female or male existed regarding Generation Y students' environmental intentions, perceived price, quality and green purchase behaviour, an independent samples t-test was performed. The results of the t-test are presented in Table 5 below:

Table 5: Gender differences

Factors	Mean		t-score	p-value
	Female	Male		
Perceived environmental intention	4.371	4.435	-0.559	0.577
Perceived environmental price	3.76	3.93	-1.034	0.302
Perceived environmental quality	3.97	3.99	-0.178	0.859
Green purchase behaviour	3.892	4.101	-1.677	0.094

Table 5 presents evidence suggesting that there are no statistically significant differences for each of the constructs between female and male Generation Y students. Even though no significant differences were detected, surprisingly male students reported higher means for all four constructs. This suggests that male Generation Y students are slightly more environmentally conscious or concerned for the environment than their female counterparts. Such findings may warrant further investigation.

CONCLUSION

As globalisation continues to steamroll the globe, the environment bears the burden of mankind's economic pursuit. Pro-environmental purchase intentions and subsequent green purchasing behaviour may alleviate some of the burdens mankind has placed on the earth's natural ecosystems. This study aimed at validating a green purchase

behaviour model, assert if females and males differ in terms of environmental behaviour and validated a measurement model to be utilised in future studies. The results suggest that the green purchase behaviour model is a two-factor model comprising environmental purchase intentions and green purchase behaviour. This model represented adequate fit and construct reliability. In addition, no significant differences were found amongst female and male students regarding their environmental purchase intentions, perceived environmental price and quality of green products and green purchase behaviour. However, it was noted that males did report higher means on all constructs than their female counterparts. Finally, the proposed measurement model adhered to all requirements that are required to perform a structural model. The future research aims to delineate the mediating effects perceived environmental price and perceived environmental quality of green products exhibit towards green purchasing behaviour.

LIMITATIONS

Various limitations arise in every study, this paper is no exception. The sampling method included a non-probability, cross-sectional approach. This approach provides but a single measurement in time and does not have the astuteness of a longitudinal study. Moreover, this study utilised a convenience sampling method, owing to that fact caution should be heeded when generalising the results to the public. This study also only looked at green products in general and did not concentrate on a specific product category.

REFERENCES

- Abdul-Muhmin, A.G. (2007). Explaining consumers' willingness to be environmentally friendly. *International Journal of Consumer Studies*, 31(3):237–247.
- Ali, A. & Ahmed, I. (2012). Environment friendly products: Factors that influence the green purchase intentions of Pakistani consumers. *Pakistan Journal of Engineering, Technology & Science*, 2(1): 84-117.
- Barton, C., Fromm, J. & Egan, C. (2012). *The Millennial consumer: debunking stereotypes*. https://www.bcgperspectives.com/content/articles/consumer_insight_marketing_millennial_consumer/. (Accessed 5 October 2012).
- Bevan-Dye, A.L. & Surujlal, J. (2011). Attitudes towards materialism in sport and materialism tendencies amongst Black Generation Y students. *African Journal for Physical, Health Education, Recreation and Dance*, September, 43-55.
- Chang, C. (2011). Feeling ambivalent about going green: Implications for green advertising processing. *Journal of Green Advertising*, 40(4), 19-31.
- Chekima, B, Wafa, S, Igau, O, Chekima, S & Sondoh S. (2016). Examining green consumerism motivational drivers: does premium price and demographics matter to green purchasing? *Journal of Cleaner Production*, 112(1): 3436-3450.
- Chen, Y.S. & Chang, C.H. (2012). Enhance green purchase intentions: the roles of green perceived value, green perceived risk, and green trust. *Management Decision*, 50(3): 1-43.
- Coleman, Y.D. (2012). East timor: 2012 country review. <http://web.ebscohost.com.nwulib.nwu.ac.za/ehost/detail?vid=6&hid=17&sid=aed96e7d-b33e-40ce-bba0-84a29f81db7a%40sessionmgr13&bdata=JnNpdGU9ZWlhvc3QtbG12ZQ%3d%3d#db=buh&AN=74240435>.
- D'Souza, C., Taghian, M. & Khosla, R. (2007). Examination of environmental beliefs and its impact on the influence of price, quality and demographic characteristics with respect to green purchase intention. *Journal of Targeting, Measurement and Analysis for Marketing*, 15(2), 69-78.
- Dangelico, M. R. & Pujari, D. (2010). Mainstreaming Green Product Innovation: Why and How Companies Integrate Environmental Sustainability. *Journal of Business Ethics*, 95(3), 471-486.

- Do Paco, A. & Raposo, M. 2009. "Green segmentation": an application to the Portuguese consumer market. *Marketing Intelligence & Planning*, 27(3): 364-379.
- Eastman, J.K. & Liu, J. (2012). The impact of generational cohorts on status consumption: an exploratory look at generational cohort and demographics on status consumption. *Journal of Consumer Marketing*, 29(2), 93-102.
- Field, A. (2009). *Discovering statistics using SPSS*. 3rd edition. London: Sage.
- Gupta, S. & Ogden, D.T. (2009). To buy or not to buy? A social dilemma perspective on green buying. *Journal of Consumer Marketing*, 26(6), 376-391.
- Hair, J.F., Black, W.C., Babin, B.J. & Anderson, R.E. (2010). *Multivariate data analysis: a global perspective*. 7th ed. Upper Saddle River, N.J.: Pearson.
- Haytko, L.D. & Matulich, E. (2008). Green advertising and environmentally responsible consumer behaviours: Linkages examined. *Journal of Management and Marketing Research*, 1: 1-10.
- Kalafatis, P.S., Pollard, M., East, R. & Tsogas, H.M. (1999). Green marketing and Ajzen's theory of planned behavior: a cross-market examination. *Journal of Consumer Marketing*, 16(5), 441-460.
- Kanchanapibul, M., Lacka, E., Wang, X. & Chan, H.K. (2014). An empirical investigation of green purchase behaviour among the young generation. *Journal of Cleaner Production*, 66 (1): 528-536.
- Kline, B.R. (2011). *Principles and practice of structural equation modelling*. 3rd ed. New York: The Guilford Press.
- Kumar, D., Kumar, I., Rahman, Z., Yadav, S. & Goyal, P. (2011). Green marketing mix: rethinking competitive advantage during climate change. *Special Issue of the International Journal of the Computer, the Internet and Management*, 19(1): 62.1-62.5.
- Laroche, M., Bergeron, J. & Barbaro-Forleo, G. (2001). Targeting consumers who are willing to pay more for environmentally friendly products. *Journal of Consumer Marketing*, 18(6), 503-520.
- Lee, K. (2008). Opportunities for green marketing: young consumers. *Marketing Intelligence & Planning*, 26(6), 573-586.
- Lee, K. (2009). Gender differences in Hong Kong adolescent consumer's green purchasing behavior. *Journal of Consumer Marketing*, 26(2), 87-96.
- Levine, D.S. & Strube, M.J. (2012). Environmental attitudes, knowledge, intentions and behaviors among college students. *The Journal of Social Psychology*, 152(3): 308-326.
- Malhotra, K.N. (2010). *Marketing research: an applied orientation*. 6th ed. Upper Saddle River, N.J: Pearson Education.
- Markert, J. (2004). Demographics of age: generational and cohort confusion. *Journal of Current Issues and Research in Advertising*, 26 (2), 11-25.
- Mostafa, M.M. (2007). A hierarchical analysis of the green consciousness of the Egyptian consumer. *Psychology & Marketing*, 24(5), 445-473.
- Niaura, A. (2013). Using the theory of planned behavior to investigate the determinants of environmental behavior among youth. *Environmental Research, Engineering and Management*, 1(63): 74-81.
- Ottman, A.J., Strafford, R. E. & Hartman, L. C. (2006). Avoiding green myopia: Ways to improve consumer appeal for environmentally friendly preferable products. *Environment: Science and Policy for Sustainable Development*, 48(5), 22-36.
- Pallant, J. (2010). *SPSS survival manual: a step by step guide to data analysis using SPSS*. 4th ed. England: Open University Press.
- Peattie, K. (2001). Towards sustainability: The third age of green marketing. *Journal of The Marketing Review*, 2(2): 129-147.
- Peattie, K., Charter, M., (2003). Green marketing. In: Baker, M.J. (Ed.), *Book Chapter: the Marketing Book*. Elsevier, Worldwide.

- Polonsky, M.J., Vocino, A., Grau, S.L., Garma, R. & Ferdous, A.S. (2012). The impact of general and carbon-related environmental knowledge on attitudes and behaviour of US consumers. *Journal of Marketing Management*, 28(3–4), 238–263.
- Rahbar, E. & Wahid, N.A. (2011). Investigation of green marketing tools' effect on consumers' purchase behavior. *Journal of Business Strategies Series*, 12(2),73-83.
- Rogers, G. (2013). The rise of Generation Y in the sustainable marketplace. *The guardian*, 3 Feb. http://www.guardian.co.uk/sustainable-business/blog/_rise-generation-y-sustainable-marketplace. (Accessed 26 February 2013).
- Smith, T.K. (2012). Longitudinal study of digital marketing strategies targeting Millennials, *Journal of Consumer Marketing*, 29(2), 86 – 92.
- Sodhi, K. (2011). Has marketing come full circle? Demarketing for sustainability. *Journal of Business Strategies*, 12(4), 177-185.
- Statistics South Africa. (2016). *Mid-year population estimates: 2016. Statistical release P0302*. <http://www.statssa.gov.za> Date of access: 4 Apr. 2017.
- Yadav, R. & Pathak, G. (2016). Young consumers' intention towards buying green products in a developing nation: Extending the theory of planned behavior. *Journal of Cleaner Production*, 135(1):732-739.

ANTECEDENTS OF MOBILE GAMING BRAND LOYALTY AMONGST SOUTH AFRICAN GENERATION Y STUDENTS: PILOT TEST RESULTS

C. Synodinos, D.G. Price & A.L. Bevan-Dye
North-West University, South Africa

ABSTRACT

This paper reports on the results of a pilot study undertaken to design a large-scale study to model the antecedents of mobile game brand loyalty amongst South African Generation Y university students. Internationally, mobile games have become a lucrative business with consumer expenditure exceeding \$35 billion. While most mobile games can be downloaded for free, obtaining the full version of the game, obtaining an advertisement-free version of the game and/or improving one's game play through in-app purchases comes at a cost. In addition to the revenue generated from advertisement placement in mobile games and in-app purchases, the developers of popular mobile games also are able to capitalise on this success through the sale of branded merchandise. While fad mobile games are likely to be able to generate revenue, realising the true revenue potential of mobile games necessitates developing and maintaining brand loyalty. This, in turn, necessitates a clear understanding of the factors that influence mobile game brand loyalty.

Keywords: Mobile games, brand loyalty, South Africa, Generation Y university students.

INTRODUCTION

The rapid dissemination of smartphones amongst consumers over the last decade has led to a plethora of mobile services being available. Of all the mobile services available, mobile application games (hereafter referred to as mobile games) have experienced the most success (Liu & Li, 2011, p.890). Mobile gaming is also a major success in South African market, with mobile gaming overtaking console video gaming in terms of revenue generated in 2016 (Pricewaterhouse Coopers, 2016, p.36). A mobile game, as a type of video game, is described as an interactive entertainment that can be played on a mobile device such as a smartphone or tablet. The object of a video game, particularly a mobile game, is to create a pleasurable experience for a player that is attained by accomplishing certain objectives set out in the game (Granic, Lobel & Engels, 2014, p.67; Jeong & Kim, 2009, p.186). Mobile games have become ubiquitous amongst smartphone users due to their portability, as well as being interactive, challenging and fun to play (Hill, 2014).

Internationally, mobile games have become a lucrative business with consumer expenditure exceeding \$35 billion (Statista, 2016). The three giants of the mobile gaming industry, Rovio (Angry Birds), King (Candy Crush Saga) and Supercell (Clash of Clans), are at the forefront of this success with their flagship mobile games becoming burgeoning brands (Loveday, 2015; Takahashi, 2014; Newzoo, 2013; Sinha, 2012; Cheshire, 2011). These mobile games are able to attract a large following of video gamers by allowing them to download the mobile game for free. Thereafter, players who enjoy the game will either purchase the full-version, make repeated in-game purchases (in-app purchases) to speed up their gameplay progress or download other mobile games from the same company (Davidovici-Nora, 2014, p.83). This type of consumer behaviour is typically linked to brand loyalty and the success of these mobile gaming 'brands' can be attributed to their ability to attract and retain brand loyal consumers (video game players) (Teng, 2013, p.884).

Pokémon Go, an augmented reality (AR) game which uses real-life locations, has been ambassador for mobile gaming marketing and branding (Waracle, 2016). Utilising the brand name of Pokémon and its large loyal consumer following, Pokémon Go had approximately 30 million users playing it every day, who spent an average of 30 minutes playing it in 2016 – which was more time spent than users on Facebook, Twitter and Instagram during that same period (Appinstitute, 2017; Smith, 2017). Mitra, a company that enables businesses and brands to capitalise on the marketing potential of mobile games like Pokémon Go, generated over \$50 million via ad revenue within seven days of the game being launched (Waracle, 2016). In addition, a significant increase in sales of Pokémon-related merchandise was also experienced in the first few months of Pokémon Go's release (Ho, 2016). This underlines the importance of mobile games - beyond revenue generation - to various organisations wishing to advertise, promote and build their brands.

LITERATURE REVIEW

The importance of brand loyalty in an organisation's success has been acknowledged by multiple academics in a variety of fields (Wu & Chien, 2015; Teng, Chen, M-Y., Chen, Y-J & Li, Y-J, 2012; Lin, 2010; Gaur & Arora, 2014). Bauer, Stockburger- Sauer and Exler (2008, p.207) state that the concept of brand loyalty must be conceptualised as a two-dimensional construct comprising attitudinal loyalty and behavioural loyalty. Attitudinal loyalty represents psychological and emotional commitment to a brand that is characterised by a consumer's willingness for a brand to succeed and resistance towards switching brands (Lu & Wang, 2008, p.504). Behavioural loyalty represents a consumer's intention to continue engaging with a brand and includes past and future purchase behaviour, as well as intentions to buy additional products related to the brand (Lii & Sy, 2009, p.772). Amine (1998, p.307) posits that higher psychological commitment to a brand typically leads to increased behavioural loyalty. As such, mobile gaming brand loyalty can be conceptualised as a player's psychological commitment and behavioural loyalty towards their favourite mobile game.

Brand identification is considered a salient predictor of brand loyalty (Lin, 2010, p.7). Literature pertaining to brand loyalty has shown that consumers who perceive a level of connectedness to a particular brand can become psychologically committed and behaviourally loyal to that brand (Parker, 2005, p.27). According to Van Looy, Courtois and De Vocht (2012, p.129), brand identification can be conceptualised as game identification and is the extent to which a player can identify himself/herself with their favourite video game, as well as with other people playing the same game. However, further evidence is needed to prove if game identification specifically predicts video game brand loyalty, as Van Looy *et al's* (2012) study did not explore this possibility.

A limited amount of studies aimed at determining potential antecedents of consumer loyalty towards video games revealed that flow is significant predictor of attitudinal loyalty (Teng, 2013; Choi & Kim, 2004). Flow is described as a holistic experience that comes about when a player becomes cognitively absorbed when playing a video game (Ha *et al.*, 2007, p.279). A study done by Teng (2013, p.885) found that flow has a positive significant impact on consumer loyalty towards a video game. This suggests that a video game that invokes a state flow will lead to a consumer being psychologically committed to playing that game, which in turn leads to behavioural loyalty towards that game. The study also found that challenge is a significant predictor of flow. Challenges posed by a video game encourage players to use cognitive skills to overcome them, which increases the cognitive concentration required when playing that game. Cognitive concentration is interchangeable with the definition of flow, thus proving the link between challenge and flow (Jung *et al.*, 2009, p.125).

Research conducted by Lu and Wang (2008) proposed that addiction and satisfaction are also important predictors of loyalty. The authors describe addiction as a player's psychological dependence on a video game, whereas satisfaction is described as the fulfilment a player perceives to experience when playing his/her favourite video game. Lu and Wang's (2008:511-512) findings revealed that video game addiction and satisfaction positively impact consumer loyalty.

As brand loyalty involves consumers, selecting an appropriate target market for a brand is of utmost importance for marketers. A study conducted by Price (2017, p.114) reveals that South African Generation Y students – also known as today's youth or the Millennials – display positive attitudes towards mobile games and

positive behavioural intentions to play them. The Generation Y cohort includes any individual born between 1986 and 2005 and represents an estimated 38 percent of the total population in South Africa (Statistics South Africa, 2015, p.9; Markert, 2004, p.21). Moreover, Generation Y members that are students at higher education institutes (HEIs) are of particular importance as they tend to develop into opinion leaders amongst their peers (Bevan-Dye & Surujlal, 2011, p.49). This suggests that their opinions on mobile games, positive or negative, are likely to influence the wider Generation Y cohort. As such, targeting the Generation Y cohort may be fruitful for marketers wishing to develop and grow an organisational brand.

RESEARCH METHODOLOGY

Sampling method

For this pilot study, 41 students registered at a campus of a South African public higher education institution were selected using convenience sampling. This campus was selected because it is not included in the sampling frame of the main study. After the purpose of the study was explained to each of the pilot study participants, they were asked if they would volunteer to complete the questionnaire.

Research instrument

The study utilised a self-administered questionnaire to gather primary data. The questionnaire comprised two sections, namely Section A which contained demographical questions and Section B, which included scales adapted from published studies to measure mobile gaming brand loyalty, as well as several identified predictors thereof. The construct of flow (six items) was measured using a scale adapted from Choi and Kim (2004, p.16-17). The scales for addiction (eight items) and satisfaction (six items) were adapted from Lu and Wang's (2008, p.518-519) study. The scale for challenge (six items) was adapted from Teng (2013, p.887). Game identification (five items) was used to conceptualise brand identification, and was measured using an adapted scale from Van Looy *et al.* (2012, p.134).

Brand loyalty, which is conceptualised as a two-dimension scale comprising psychological commitment and behavioural loyalty, was measured using scales adapted from Prichard, Havitz and Howard (1999, p.345) and Bauer *et al.* (2008, p.225). In the behavioural loyalty scale, two items from the original Bauer *et al.* (2008, p.225) scale were excluded for being irrelevant to mobile games, namely "I will often attend games of my favourite team live in the stadium" and "I will watch games of my favourite team on TV". In their place, the two item online gaming consumer loyalty scale from Choi and Kim's (2004, p.16) study comprising "The online game was overall satisfactory enough to reuse later" and "I would re-use this online game when I want to play online games later" were used. In addition, the following item was added to the scale, "I would follow the latest news and updates about my favourite mobile game on social media platforms (Facebook, Twitter, Instagram etc.)", due to the growing relevance and popularity of social media amongst today's youth (Generation Y) (Barton, Fromm & Egan, 2012, p.4).

The questionnaire measured scaled responses using a six-point Likert scale ranging from 1 = strongly disagree to 6 = strongly agree. Furthermore, a cover letter explaining the nature of the study, as well as relevant contact details accompanied the questionnaire.

Data analysis

The captured data was analysed using the Statistical Package for Social Sciences (SPSS), Version 24.0 for Windows. The intention for the main study is to use the multivariate statistical method of structural equation modelling (SEM) to model the antecedents of mobile game brand loyalty amongst South African Generation Y university students. As such, it was important to do a preliminary data analysis in the pilot study on several aspects.

Identifying systematic missing values using frequency analysis can be useful in identifying potential sources of non-response error, such as inability to answer errors (Malhotra, 2010, p.119).

Given that values that deviate substantially from other values in a data set have a significant influence on the correlation coefficient and, hence, also the Cronbach alpha measure of internal-consistency reliability in small samples (Pallant, 2010, p.123), it is essential to identify outliers in order to prevent drawing the wrong conclusions from a pilot study. Outliers are screened using the Mahalanobis distance, with the $p < 0.001$ criterion. Any case with a Mahalanobis distance greater than chi-square (degrees freedom, represented by the number of constructs) represents an outlier and should be deleted from the data set (Tabachnick & Fidell, 2014, p.108). In this pilot study, seven constructs were tested. Therefore, any case with a Mahalanobis distance greater than 24.322 (chi-square value for $\alpha=0.001$ at 7 df) would constitute an outlier.

It is also advisable to check the normality of the data distribution in the case of small samples. This can be done by converting the skewness and kurtosis values of constructs into Z-scores. Skewness and kurtosis z-scores that are significant ($p < 0.01$) are indicative of a departure from normality (Field, 2009, p.139).

Once the absence of systematic missing values and outliers, together with the normality of the data has been established, it is possible to draw tentative conclusions from a pilot study. One of the first things that need to be assessed in the case of multi-item scales is the internal-consistency reliability of those scales. The most robust measure of internal-consistency reliability is the Cronbach alpha, where an alpha value above 0.60 suggests acceptable reliability (Malhotra, 2010, p.319). Measures of location, such as the mean in the case of constructs comprising scaled responses, provide interesting insight into the level of agreement/disagreement participants have towards statements making up a construct. Given the six-point scale utilised in this pilot study, means equal to or greater than 3.5 would indicate the agreement portion of the scale. When the intention is to use multivariate statistical technique in a main study, it is advisable to check for any multicollinearity between constructs in the pilot study. For this study, collinearity diagnostics were carried out on the constructs, with the case number serving as the dummy dependent variable. Generally, tolerance values above the cut-off level of 0.10, and an average variance inflation factor (VIF) below the cut-off of 10 are indicative of no serious multicollinearity (Pallant, 2010, p.158). In the case of SEM, it is also important to establish the nomological validity of a proposed measurement model. In a pilot study, an indication of the possible nomological validity may be obtained by constructing a matrix of Pearson's Product-Moment correlation coefficients. When there is statistically significant correlation ($p < 0.05$) between the pairs of constructs, nomological validity may be assumed (Hair, Black, Babin & Anderson, 2014, p.710).

RESULTS

In order to check for missing values, a frequency analysis of the scaled items was conducted. The results indicated no missing values, suggesting that there were no problematic items. Thereafter, using the case numbers as a dummy dependent variable, outliers were screened using the Mahalanobis distance statistic. Table 1 reports the 10 highest Mahalanobis distance statistics generated by SPSS.

Table 1: Outlier statistics

	Case number	Statistic
Mahal. distance	1	23
	2	4
	3	11
	4	20
	5	32
	6	28
	7	18
	8	34
	9	14
	10	6

As shown in Table 1, no outliers were evident given that no cases had a Mahalanobis distance greater than 24.322 (chi-square value for $\alpha=0.001$ at 7 df). Next, the descriptive statistics, skewness and kurtosis z-values, and Cronbach alpha values were computed, as presented in Table 2.

Table 2: Descriptive statistics, z-scores and Cronbach alpha values

Constructs	Means	Standard deviations	Skewness statistic	Skewness standard error	Skewness z-score	Kurtosis statistic	Kurtosis standard error	Kurtosis z-score	Cronbach alpha
Addiction	3.68	0.83	0.01	0.37	0.49	-0.45	0.72	0.27	0.65
Satisfaction	4.45	0.74	-0.62	0.37	0.05	0.00	0.72	0.50	0.64
Challenge	4.05	0.92	-0.02	0.37	0.48	-0.24	0.72	0.37	0.70
Identification	3.43	1.31	0.01	0.37	0.49	-1.02	0.72	0.08	0.88
Flow	4.48	0.85	-0.74	0.37	0.02	0.16	0.72	0.41	0.77
Commitment	3.79	1.13	-0.11	0.37	0.38	-0.74	0.72	0.15	0.82
Loyalty	3.51	0.99	-0.05	0.37	0.44	-0.71	0.72	0.16	0.78

In terms of the normality of the data, the non-significant ($p > 0.01$) skewness and kurtosis z-scores suggest that the data is normally distributed. As is evident from Table 2, all Cronbach alpha values exceeded the 0.60 level, thereby suggesting acceptable internal-consistency reliability. Mean values above 3.5 were computed for six of the seven constructs. This suggests that Generation Y students are addicted to their favourite mobile games (mean = 3.68), experience satisfaction (mean = 4.45), challenge (mean = 4.05) and flow (mean = 4.48) when playing such games, and are brand loyal to their favourite mobile games in terms of their psychological commitment (mean = 3.79) and behavioural loyalty (mean = 3.51). The only mean below the 3.50 mark was the one for identification (mean = 3.43). This lower mean may be because many mobile games typically use a low-level of animation realism and are much more simplistic than traditional console video games, which may make it difficult to identify with on a personal level.

Prior to constructing the correlation matrix, collinearity diagnostics were run. Tolerance values ranged between 0.34 and 0.57 (> 0.10) and the average VIF was 2.12 (< 10). As such, multicollinearity did not appear to be a major issue. Thereafter, a correlation matrix was constructed to assess the nomological validity of the model proposed for testing in the main study, as presented in Table 3.

Table 3: Correlation matrix

	Addiction	Satisfaction	Challenge	Identification	Flow	Commitment
Satisfaction	0.419*					
Challenge	0.453*	0.541*				
Identification	0.685*	0.359*	0.423*			
Flow	0.422*	0.615*	0.627*	0.471*		
Commitment	0.479*	0.445*	0.425*	0.597*	0.390*	
Loyalty	0.533*	0.410*	0.424*	0.693*	0.368*	0.655*

* Significant at $p < 0.05$

The correlation coefficients reported in Table 3 indicate that there is statistically significant ($p < 0.05$) positive correlation between each of the pairs of constructs proposed for inclusion in the model to be tested in the main study, thereby suggesting nomological validity.

CONCLUSION

This paper reported on the results of a pilot study conducted to do a preliminary data analysis before designing a large-scale study to model the determinants of mobile game brand loyalty amongst South African Generation Y university students. The purpose of the pilot study was to test whether the proposed research instrument scales would be suitable for SEM in the main study. After testing for missing data and outliers, the skewness and kurtosis statistics were converted into z-scores. The computed skewness and kurtosis z-scores were not statistically significant, thereby suggesting that the data are normally distributed. The internal-consistency reliability of the scales proposed for inclusion in the main study was tested using Cronbach's alpha. Cronbach alpha values above 0.60 were computed on each construct, which suggests that the constructs exhibit acceptable internal-consistency reliability. The nomological validity of the proposed measurement model was evaluated by constructing a Pearson's Product-Moment correlation matrix. The coefficients in the matrix show that there is statistically significant correlation between each of the pairs of constructs proposed for inclusion in the model. In addition, the direction of the relationships is in line with that suggested in the literature. Collinearity diagnostics were run on the constructs to check for multicollinearity. The results provide no indication of multicollinearity between the constructs. Therefore, the research instrument appears suitable for applying SEM on the data from the main study. As such, based on the findings of this pilot study, it is hypothesised that South African Generation Y students' mobile game brand loyalty is a seven-factor model comprising behavioural loyalty, psychological commitment, flow, game identification, challenge, satisfaction and addiction.

REFERENCES

- Amine, A. (1998). Consumers' true brand loyalty: the central role of commitment. *Journal of strategic marketing*, 6(4), 305-319.
- Barton, C., Fromm, J. & Egan, C. (2012). *The Millennial consumer: debunking stereotypes*. Retrieved from <https://www.bcgperspectives.com/content/articles/consumer-insight-marketing-millennial-consumer>
- Bauer, H.H., Stokburger-Sauer, N.E. & Exler, S. (2008). Brand image and fan loyalty in professional team sport: a refined model and empirical assessment. *Journal of Sport Management*, 22(2), 205-226.
- Bevan-Dye, A.L. & Surujlal, J. (2011). Attitudes towards materialism in sport and materialism tendencies amongst Black Generation Y students. *African Journal for Physical, Health Education, Recreation and Dance*, 17(4), 43-55.
- Cheshire, T. (2011). *In depth: how Rovio made Angry Birds a winner (and what's next)*. Retrieved from <http://www.wired.co.uk/article/how-rovio-made-angry-birds-a-winner>
- Choi, D. & Kim, J. (2004). Why people continue to play online games: in search of critical design factors to increase customer loyalty to online contents. *Cyber Psychology & Behavior*, 7(1), 11-24.
- Davidovici-Nora, M. (2014). Paid and free digital business models innovations in the video game industry. *Digiworld Economic Journal*, 94(2), 83-102.
- Field, A. (2009). *Discovering statistics using SPSS*. Sage publications.
- Gaur, A. & Arora, N. (2014). Effect of age and gender on brand loyalty and customer satisfaction: a study of mobile phone user. *SIES Journal of Management*, 10(2), 22-30.
- Granic, I., Lobel, A. & Engels, R. (2014). The benefits of playing video games. *American Psychologist*, 69(1), 66-78.

- Ha, I., Yoon, Y. & Choi, M. (2007). Determinants of adoption of mobile games under mobile broadband wireless access environment. *Information & Management*, 44(3), 276–286.
- Hair, J., Black, W., Babin, B. & Anderson, R. (2014). *Multivariate data analysis* (7th ed.). Harlow, Essex: Pearson.
- Hill, S. (2014). *Common traits of successful casual mobile games*. Retrieved from <https://crowdsourcedtesting.com/resources/mobile-games>
- Ho, K.K. (2016). *Pokemon Go frenzy boosts real-life merchandise sales*. Retrieved from <http://www.theglobeandmail.com/life/pokemon-go-boosts-real-life-merchandise-sales/article31376529>
- Jeong, E.J & Kim, D.J. (2009). Definitions, key characteristics, and generations of mobile games. *Encyclopedia of Mobile Computing and Commerce*, 1(1), 185-189.
- Jung, Y., Perezmira, B. & Wileypatton, S. (2009). Consumer adoption of mobile TV: examining psychological flow and media content. *Computers in Human Behaviour*, 25(1), 123–129.
- Lii, Y.S. & Sy, E. (2009). Internet differential pricing: effects on consumer price perception, emotions, and behavioral responses. *Computers in Human Behavior*, 25(3), 770-777.
- Lin, L.Y. (2010). The relationship of consumer personality trait, brand personality and brand loyalty: an empirical study of toys and video games buyers. *Journal of Product & Brand Management*, 19(1), 4-17.
- Liu, Y. & Li, H. (2011). Exploring the impact of use context on mobile hedonic services adoption: An empirical study on mobile gaming in China. *Computers in Human Behavior*, 27(2), 890–898.
- Loveday, S. (2015). *King bolsters Candy Crush brand with three new agents*. Retrieved from <http://www.licensing.biz/news/read/king-bolsters-candy-crush-brand-with-three-new-agents/041581>
- Lu, H.P. & Wang, S.M. (2008). The role of Internet addiction in online game loyalty: an exploratory study. *Internet Research*, 18(5), 499-519.
- Malhotra, N.K. (2010). *Marketing research: an applied orientation* (6th ed.). Upper Saddle River, New Jersey: Pearson Education.
- Markert, J. (2004). Demographics of age: generational and cohort confusion. *Journal of Current Issues and Research in Advertising*, 26(2), 11-25.
- Newzoo. (2013). *Supercell vs King: How do Clash of Clans and Candy Crush gamers compare?* Retrieved from <https://newzoo.com/insights/articles/supercell-vs-king-how-do-their-gamers-compare>
- Pallant, J. (2010). *SPSS survival manual: a step by step guide to data analysis using SPSS* (4th ed.) Maidenhead: Open University/McGraw-Hill.
- Parker, B.T. (2005). *This brand's for me: Brand personality and user imagery based self-congruity* (Doctoral thesis). Retrieved from http://etd.fcla.edu/UF/UFE0012900/parker_b.pdf
- Price, D.G. (2017). *Drivers of mobile game adoption amongst Generation Y students* (Unpublished master's dissertation). North-West University, Vanderbijlpark.
- Pritchard, M.P., Havitz, M.E. & Howard, D.R. (1999). Analyzing the commitment-loyalty link in service contexts. *Journal of the Academy of Marketing Science*, 27(3), 333-348.
- Pricewaterhouse Coopers. (2016). *PwC's South African entertainment and media outlook: 2016-2020*. Retrieved from <http://www.pwc.co.za>.

Sinha, C. (2012). *What's Dopamine got to do with Angry Birds?* Retrieved from <http://www.chlorophyllblog.com/branding/whats-dopamine-got-to-do-with-angry-birds>

Statista. (2016). *Mobile gaming app revenue worldwide in 2015, 2016 and 2020 (in billion U.S. dollars)*. Retrieved from <http://www.statista.com/statistics/511639/global-mobile-game-app-revenue>

Statistics South Africa. (2015). *Mid-year population estimates: 2015. Key indicators, Statistical release P0302*. Retrieved from <http://www.statssa.gov.za/publications/P0302/P03022015.pdf>

Tabachnick, B. G., Fidell, L. S., & Osterlind, S. J. (2014). *Using multivariate statistics*. 6th edition. Harlow, Essex, UK: Pearson.

Takahashi, D. (2014). *Tactile Entertainment wants to join Supercell, Rovio, and King as a Nordic mobile-gaming wonder*. Retrieved from <http://venturebeat.com/2014/08/14/tactile-entertainment-wants-to-be-the-next-nordic-mobile-gaming-wonder>

Teng, C.I., Chen, M.Y., Chen, Y.J. & Li, Y.J. (2012). Loyalty due to others: the relationships among challenge, interdependence, and online gamer loyalty. *Journal of Computer-Mediated Communication*, 17(4), 489-500.

Teng, C.I. (2013). How do challenges increase customer loyalty to online games? *Cyberpsychology, Behavior, and Social Networking*, 16(12), 884-891.

Van Looy, J., Courtois, C., De Vocht, M. & De Marez, L. (2012). Player identification in online games: validation of a scale for measuring identification in MMOGs. *Media Psychology*, 15(2), 197-221.

Wu, Y.L. & Chien, W.J. (2015). The effect of mobile gamification on brand loyalty. In *Twenty-First Americas Conference on Information Systems*, 1-14.

IDENTIFYING CRITICAL ETHICAL ISSUES IN THE HOSPITALITY WORKPLACE: THE EMPLOYEE PERSPECTIVE

Chih-Ching Teng, Shih-Min Hsu, and Shan-Shan Cheng
Fu Jen Catholic University, Taiwan

ABSTRACT

This study investigated ethical issues from hotel employee perspective. A self-administered questionnaire was incorporated into this study. A total of 400 participants from 13 hotels were recruited in this study. Factor analysis was conducted to identify the underlying factors that portray the perception of hotel employees towards the ethical issues in the hospitality workplace. A total of six factors, corporate integrity, personal integrity, customer equity, customer integrity, personal misbehavior, and self-benefit were generated from the EFA. By adding the above aspects into the training program, it would improve hotel employees' ethical awareness and the overall work environment.

Keywords: Ethical issue, Ethical perception, Workplace ethics, Hospitality industry.

INTRODUCTION

Research in business ethics has drawn considerably attention across many fields, including the hospitality industry. Previous studies stressed that it is important to incorporate and implement ethical practices in the hospitality workplace as ethical issues have become one of the major challenges that need to be focused in the hospitality industry (Huimin & Ryan, 2011, p.884). Specifically, hospitality employees play a significant role to corporate ethical performance. This implies that the levels of corporate ethics rely largely on employee ethical decisions and related behaviors. Employees felt low wages or treated unfairly, they may make unethical behavior, such as theft (Goh & Kong, 2016, p.10). Since hospitality employees have more opportunities encountered ethical issues and exposed to daily ethical dilemmas in the workplace (Reynolds, 2000; Stevens, 2001, p.234). The business ethical value had an influence on person-organization fit (Jung, Namkung, & Yoon, 2010, p.543), there is a pressing need to identify ethical issues that is critical and common in the hospitality workplace in order to prevent unethical issues as well as initiate ethical training and practices for employees. Prior research has indicated that a high level of ethics in the work environment will increase employee ethical perceptions and values, which in turn will enhance employee satisfaction and organizational profitability (Kim & Miller, 2008, p.1025; Pettijohn, Pettijohn, & Taylor, 2008, p.550). With high level of ethics in the working place, employees ethical decision-making will also be improved (Valentine, Goodkin, & Mandabach, 2014, p.229). Accordingly, understanding the current employee' awareness of critical ethical issues is crucial for the hospitality industry to develop ethical education training program. High employees' ethical awareness and ethical behaviors will eventually lead to the sustainability of business. It has become the responsibility of hospitality managers to ensure employees possess a strong ethical belief and the ability to handle ethical problems upon their work.

An understanding of workplace ethics has become a highly relevant topic and has raised industrial and educational concern about the ethical issues in the hospitality workplace. Weaver, Choi, and Kaufman (1997) found that ethical issues in the hospitality workplace incorporate personal behaviors, customer relationships, work rules,

employment, and the environment (p.23). Wong and Chan (2010) identified four main unethical aspects that hotel front-line employees often encounter, including embezzlement of guests' property, benefit self at the expense of guests, against work rules, and unethical behaviors (p.441). Through the process of identifying ethical issues in the work environment, employees will be less likely to conduct unethical acts in the workplace (Goh & Kong, 2016, p.10). However, at present, few studies have looked into employee perceptions of ethical issues in order to determine critical ethical issues for the hospitality industry. Therefore, the objective of this study is to identify critical ethical issues in the hospitality workplace based on the employee perspective.

The findings of this study could provide empirical evidence of critical ethical issues that need to be incorporated into the topics of hospitality ethics education. Moreover, the implications of this study could help hospitality managers realize which ethical aspects are commonly ignored or misunderstood that need to be corrected in order to develop an ethical work environment.

METHODOLOGY

This study used a self-administered questionnaire to investigate employee ethical perceptions of the hospitality workplace, especially in international tourist hotels in Taiwan. A six-point Likert-type scale, ranging from "1" extremely disagree to "6" extremely agree, was used to measure respondent perceptions towards each unethical statement in the workplace. Through the processes of the literature review, industrial professional interviews, and the expert validity, a total of 38 unethical statements were generated as a measure for this study. The questionnaire was divided into two sections. The first section was designed to elicit respondents' perceptions towards various ethical issues in the hospitality workplace. The section asked questions related to the respondent's personal characteristics, including gender, age, education level, years working in the industry, and ethical educational training experience.

Descriptive statistics were performed to summarize the demographic profiles of the respondents and the means and standard deviation for the unethical statements were also reported. The exploratory factor analysis (EFA) was conducted to identify the underlying factors of the study.

RESULTS

To collect data, 455 questionnaires were distributed within 13 international tourist hotels and 400 were completed and considered valid for analysis, which resulted in 87.9% of response rate. Female employees made up the majority of the respondent population (56.6%) whereas 43.4% were male. More than half of the respondents (64.3%) unmarried, while 35.7% of the respondents married. About 5.0% of the respondents were under the age of 19, aged 20-29 employees accounted for 45.8%, aged 30-39 employees accounted for 27.2%, aged 40-49 employees accounted for 17.0%, aged 50-59 employees accounted for 4.5%, and approximately 0.5% were higher than 60. As for the education level, 21.9% of the respondents were high school, 16.2% of the respondents were junior college, 55.3% of the respondents were university, and 6.7% of the respondents were graduate schools. About the years working in the industry, 12.1% of the respondents claimed that they had working years less than one year, 1-5 year working experience accounted for 45.7%, 6-10 year working experience accounted for 17.6%, 11-15 year working experience accounted for 11.6%, 15-20 year working experience accounted for 8.1%, and 4.9% had more than 20 year working experience, with the average years of 6.94. As for the ethical educational training experience, 67.1% of the respondents claimed that they had ethical training experience whereas 32.9% without such experience.

The EFA was conducted to identify the underlying factors that portray the perceptions of hospitality employees towards hospitality ethical issues in Taiwan. With the factor analysis using principal axis factoring with Varimax rotation, the eigenvalues of all the factors were all greater than 1. The statements with factor loadings less than 0.5 were deleted, resulting in 33 items left. The Kaiser-Meyer-Olkin (KMO) for the data in this study was

found to be 0.94, and it was concluded that factor analysis was valid. A total of six factors generated from the EFA and together they explained 65.27% of the cumulative variance.

Factor 1: Corporate Integrity

The first identified factor was named “corporate integrity”, as 13 statements in this factor were related to corporate ethical issues. The factor mean was 5.38 while the Cronbach’s alpha was 0.94. Items such as “The company does not follow Labor Standards Act”, and “The company hides the revenue for the tax evasion” were indicated as the most serious ethical issues in this factor (mean = 5.51) while the item “Increase employee workloads maliciously” obtained the lowest score among the unethical statements in this factor (mean = 5.20).

Factor 2: Personal Integrity

The second factor consisted of four unethical statements and it was labeled as “personal integrity.” The factor mean was 5.69 while the Cronbach’s alpha was 0.93. “Peculate corporate funds” was indicated as the most unethical statement in this factor (mean = 5.72) while “Embezzle lost and found properties” was considered as least unethical issue in this factor (mean = 5.62).

Factor 3: Customer Equity

The third identified factor was named “customer equity”, as four unethical statements in this factor are related to customer equity. The Cronbach’s alpha was 0.87 while the factor mean 4.73 was the lowest among the identified six factors. “Provide wrong information to customer” was identified as the most unethical statement (mean = 4.94) in this factor while “Do not follow work standard operating process (SOP)” was considered as the least unethical statement in this factor (mean = 4.51).

Factor 4: Customer Integrity

The fourth identified factor was named “customer integrity”, as four unethical statements in this factor are related to customer behavior. The factor mean was 5.58 while the Cronbach’s alpha was 0.86. “Guests falsely accuse employees of stealing guest’s belongings” was identified as the most unethical statement (mean = 5.67) in this factor while “Hotel guests sneak guest room items” was indicated as the least unethical statement in this factor (mean = 5.48).

Factor 5: Personal Misbehavior

The fifth factor consisted of four unethical statements was labeled as “personal misbehavior.” The factor mean was 5.32 while the Cronbach’s alpha was 0.87. “Leak inside information of the company” was identified as the most unethical statement in this factor (mean = 5.42) while “Violate corporate norms or employee rules, such as help colleagues punch in/out (mean = 5.16) was considered as the least unethical statement in this factor.”

Factor 6: Self Benefit

The sixth factor consisted of three unethical statements was labeled as “self benefit.” The factor mean was 5.43 while the Cronbach’s alpha was 0.87. “Take corporate funds for personal use” was identified as the most unethical statement in this factor (mean = 5.59) while “Give exceeded discounts without permission” (mean = 5.30) was considered as the least unethical statement in this factor.”

DISCUSSION

This study aims to examine employee perceptions of workplace ethics in the context of hospitality industry. A total of six factors, including “corporate integrity”, “personal integrity”, “customer equity”, “customer integrity”, “personal misbehavior”, and “self benefit”, were identified as the main areas of hospitality ethics that need to be focused and continually reinforced to develop positive employee and organizational ethics. According to the findings of this study, the majority of items were scored above 5.00 in a 6-point Likert scale, indicating that most employee respondents were able to identify ethical issues critical to the hospitality workplace. However, the items/factors with lower means should be paid particular attention since they are confusing or unaware by the respondents. For instance, the factor of “customer equity” (4.73) was rated below 5.00. Those items underlying this factor consequently need to be specifically clarified and understood in order to correct the misconceptions of workplace ethics that can further improve the ability of ethical judgement and decision making of hospitality employees. Study results can help hotel managers develop efficient ethical training program for employees to enhance their ethical behavior and professional performance. Hotel managers are recommended to develop "customer equity" related training programs to assist first-line employees to increase customer satisfaction. Some topics in this aspect include “responding customer needs in time,” “keeping promise,” “providing correct information,” and “following SOP.” Hotels need to continuously evaluate and enhance employee ability for varied ethical challenges. To train hotel managers by using this study results, hotels may give priority on "Corporate Integrity" and "Self Benefit" ethical issues, including "Increase employee workloads maliciously" and "Give exceeded discounts without permission". Additionally, managers from each hotel department should work together to enhance ethical implementation in the hotel industry (Wang, 2014, p.930).

REFERENCES

- Goh, E., & Kong, S. (2016). Theft in the hotel workplace: Exploring frontline employees' perceptions towards hotel employee theft. *Tourism and Hospitality Research*, 0(0), 1-14.
- Huimin, G., & Ryan, C. (2011). Ethics and corporate social responsibility—An analysis of the views of Chinese hotel managers. *International Journal of Hospitality Management*, 30(4), 875-885.
- Jung, H. S., Namkung, Y., & Yoon, H. H. (2010). The effects of employees' business ethical value on person–organization fit and turnover intent in the foodservice industry. *International Journal of Hospitality Management*, 29, 538-546.
- Kim, Y., & Miller, G. (2008). Perceptions of the ethical climate in the Korean tourism industry. *Journal of Business Ethics*, 82(4), 941-954.
- Pettijohn, C., Pettijohn, L., & Taylor, A.J. (2008). Salesperson perceptions of ethical behaviors: Their influence on job satisfaction and turnover intentions. *Journal of Business Ethics*, 78(4), 547-557.
- Stevens, B. (2001). Hospitality ethics: responses from human resource directors and students to seven ethical scenarios. *Journal of Business Ethics*, 30, 233–242.
- Valentine, S., Goodkin, L., & Mandabach, K. (2014). Ethical employment context and ethical decision-making in hospitality organizations located in Mexico and the United States. *Journal of Quality Assurance in Hospitality and Tourism*, 15, 227-252.
- Wang, C. J. (2014). Do ethical and sustainable practices matter? Effects of corporate citizenship on business performance in the hospitality industry. *International Journal of Contemporary Hospitality Management*, 26(6), 930-947.
- Weaver, P., Choi, J., & Kaufman, T. (1997). Question wording and response bias: Students' perceptions of ethical issues in the hospitality and tourism industry. *Journal of Hospitality and Tourism Education*, 9(2), 21-26.
- Wong, C. K. A., & Chan, A. (2010). Understanding the leadership perceptions of staff in China's hotel industry: Integrating the macro-and micro-aspects of leadership contexts. *International Journal of Hospitality Management*, 437–447.

MEASUREMENT AND EVALUATION OF INNOVATIVE CAPACITY AND INNOVATION PERFORMANCE OF SMALL AND MEDIUM-SIZED ENTERPRISES

**José Eduardo de Oliveira Trindade and
Maria Fatima Ludovico de Almeida
Pontifical Catholic University of Rio de Janeiro, Brazil**

ABSTRACT

This article aims to propose a model to measure and evaluate the innovative capacity (IC) and innovation performance (IP) of small and medium enterprises (SMEs), from the perspective of stimulating the improvement of innovation management processes by these firms and contributing to the formulation or revision of Science, Technology, and Innovation (ST&I) public policies focusing on this segment. The research can be considered descriptive, methodological and applied. Based on the results of the literature review on the central themes of this research, a conceptual model for measuring and evaluating the innovative capacity and innovation performance of SMEs was developed. For this, two multiple criteria decision-making (MCDM) were combined - Analytical Hierarchy Process (AHP) and Technique for Order of Preference by Similarity to Ideal Solution (TOPSIS). Besides, linear regression analysis was employed to identify the innovative capacity factors that most influence the innovation performance of these companies. Aiming to demonstrate the applicability of this model in the context of SMEs, an empirical study was carried out with 30 SMEs located in Rio de Janeiro (Brazil) and coming from different sectors of the local economy. The main contributions of the research are a model for measuring and evaluating the innovative capacity and innovation performance of SMEs that allowed the definition of IC and IP indicators, besides the identification of the factors of the innovative capacity that most influence the innovation performance of these companies. The research results could confirm the hypothesis that greater innovative capacity of SMEs contributes to reach higher levels of innovation performance.

Keywords: Innovative capacity measurement; small and medium enterprises; multiple criteria decision-making; linear regression analysis.

INTRODUCTION

The theme "measurement and evaluation of innovative capacity and innovation performance of companies" has been one of the major concerns of academics, corporate managers, and policy makers. Focusing the small and medium enterprises (SMEs), the knowledge and adoption of good practices of innovation management have taken a crucial role in the survival and growth of these companies, once new sources of competitive advantages in relation to their competitors can be generated through innovations.

From the perspective of contributing to the advancement of knowledge about measurement of the innovative capacity (IC) and the innovation performance (IP) in the context of SMEs, this paper aims to propose a model to measure and evaluate the IC and IP of SMEs, in an attempt to improve the process of innovation management by these enterprises and to contribute to the formulation/revision of Science, Technology, and Innovation (ST&I) public policies focusing on this segment.

In this context, this paper addresses the following research questions: How to measure and evaluate the innovative capacity and innovation performance of SMEs, considering their management specificities? How can

multiple criteria decision-making (MCDM) methods contribute to measure and evaluate IC and IP of SMEs? Is there a correlation between IC and IP of SMEs? In the positive case, does the innovative capacity of SMEs improve their innovation performance?

Measuring innovative capacity and innovation management at the firm-level is a difficult task in function of the complexity of the processes involved, and also because of the effort needed to define the variables to be measured. (Chiesa, Coughlan, & Voss, 1996; Crossan & Apaydin, 2010; Arundel & Hollanders, 2006; Armbruster et al., 2008). In recent years several academic studies have attempted to overcome the challenge to measure the innovative capacity and innovation performance of firms. They focused on processes and practices instead of resources (inputs) or new products/processes (outputs) (e.g. Chiesa et al., 2008; Yam et al., 2004; Guan et al., 2006; Koc & Ceylan, 2007; Wang et al., 2008; Boly et al., 2014). The multidimensionality of innovation management as a result of complex interactions of R&D management, business models improvement, new products launching, and protection of intellectual assets justify the investigation of the applicability of MCDM methods for measuring the innovative capacity and innovation performance of SMEs.

This article is structured as follows: Initially, the theoretical approaches for measuring innovative capacity and innovation performance of firms are described, with particular attention to SMEs. From the perspective of these companies, empirical studies are also analyzed, seeking to identify the decision support methods that have been adopted for the definition of IC and IP indicators and metrics in the context of SMEs. In section 3, the research methodology is presented, highlighting its components and methods, according to its main phases: (i) exploratory; (ii) applied research; and (iii) conclusive. The conceptual model for the measurement and evaluation of IC and IP of SMEs is presented in section 4. The model comprises four phases: (i) Analytical Hierarchy Process (AHP) phase, in which the weights for the criteria and subcriteria for the measurement of IC and IP of SMEs are defined; (ii) Technique for Order of Preference by Similarity to Ideal Solution (TOPSIS) phase, in which SMEs are ranked, according to their IC and IP indexes; (iii) simple linear regression analysis phase to demonstrate the positive correlation between innovative capacity and innovation performance in the context of SMEs; (iv) multiple linear regression analysis phase to identify the innovative capacity factors that most influence the innovation performance of SMEs.

In section 5, we report and discuss the results of an empirical study carried out with 30 MPMEs participating in the NAGI Program of PUC-Rio (Brazil), demonstrating the potential of applying the proposed model. Finally, section 6 formulates the conclusions and addresses proposals for future studies, such as natural unfolding and deepening of relevant aspects that emerged from this work.

THEORETICAL BACKGROUND

The theoretical background encompasses the following themes: (i) characterization of small and medium enterprises; (ii) innovative capacity and innovation performance measurement of companies, with particular attention to SMEs; and (iii) MCDM methods.

Small and medium enterprises

Before going any further, let us define small and medium enterprises for the intended modeling and the development of an empirical study carried out in the Brazilian context. Enterprises can be classified into different categories according to their size. For this purpose, different criteria may be used, but the most common refers to the number of people employed: small and medium-sized enterprises (SMEs) employ fewer than 250 people (OECD, 2016). SMEs are further subdivided into micro enterprises (less than ten employees), small enterprises (10 to 49 employees), medium-sized enterprises (50 to 249 employees).

In Brazil, micro and small enterprises (MSEs) currently account for 95% of Brazilian firms, generate some 16.6 million formal sector jobs, and contribute 20% to GDP. Over the last three decades of the 20th century, Brazil implemented a series of measures to encourage the formalization of micro and small enterprises and to promote the creation of formal employment in this segment of companies (ILO, 2014). The 2006 General Law governing micro and small enterprises in this country considers as the micro-enterprise and small business that

company or individual entrepreneur with annual gross revenue of up to BRL\$ 360,000.00 (microenterprise), or between BRL \$ 360,000.01 and BRL \$ 3,600,000.00 (small business).

Innovative Capacity and Innovation Performance Measurement

The innovation capability measurement is a field of study that has been attracting interest from scholars, consulting firms, and practitioners. Among recent relevant works on this subject, we can mention Guan *et al.* (2006); Wang *et al.* (2008); Yam *et al.* (2004); Forsman (2011); Zawislak *et al.* (2012); Doroodian *et al.* (2014); and Boly *et al.* (2014). Despite these significant advances, there is still no consensus on the concept of innovative capability. For this research, we adopted the OECD's conceptualization as follows:

“ The propensity of a firm to innovate depends, of course, on the technological opportunities it faces. Also, firms differ in their ability to recognize and exploit technological opportunities. To innovate, a firm must figure out what these occasions are, set up an appropriate strategy, and have the capabilities to transform these inputs into a real innovation – and do so faster than its competitors. But it would be misleading to stop there. Many technological opportunities do not just arise on their own but are devised by firms to fulfill some strategic goal. Innovative capacity consists of a set of factors, which the firm either has or has not, and ways of combining these factors efficiently" (OECD, 1997, p.22).

Previous research in the field of innovation capability measurement have shown that most of the proposed approaches for assessing and measuring the innovative capacity of firms are based on multi-criteria decision-making methods (MCDM) (Arundel & Hollanders, 2006; Armbruster *et al.*, 2008; Chiesa *et al.*, 2008; Yam *et al.*, 2004; Guan *et al.*, 2006; Koc & Ceylan, 2007; Wang *et al.*, 2008; Galvez *et al.*, 2013; Doroodian *et al.*, 2014; and Boly *et al.*, 2014).

Focusing on French SMEs, Boly *et al.* (2014, p. 609) point out that the multiple factors influencing the innovative capacity are common to most of the SMEs analyzed. The main difference resides in the method used for assessing and measuring their innovative capacity. From this perspective, MCDM methods have been widely applied to these studies, but since a single method is not sufficient to answer the research question, there exists a need to implement an integrated approach to solving this problem.

Multiple-criteria Decision Making (MCDM) Methods

A systematic literature search was performed on peer-reviewed articles that were published between January 2000 and July 2016, by using the following keywords "multiple criteria decision-making," "MCDM", "multi-criteria decision-making", with Boolean operator OR. It revealed that several researchers have attempted to integrate MCDM methods for different applications (Vinodh *et al.*, 2014; Taylan *et al.*, 2016; Choudhary & Shankar, 2012; Wittstruck & Teuteberg, 2012, as examples). Particularly, for measuring the innovative capability and innovation performance of SMEs, difficulties exist in determining how each criterion impacts the attributes for evaluating SME's innovative capacity associated with the level of perceived effectiveness of the adopted good practices (Qu, 2010; Sepulveda *et al.*, 2010; Forsman, 2011; Enjolras *et al.*, 2014; Sepulveda & Vasquez, 2014; Boly *et al.*, 2014; Ekuobase & Olutayo, 2015).

The integration of MCDM methods focusing the measurement and evaluation of the innovative capacity and innovation performance of SMEs is found to be scant (Ran and Wang, 2015; Lin *et al.*, 2013; Zhu and Lei, 2012; Kong *et al.*, 2008; and Wang *et al.*, 2008). In fact, we identify several opportunities to explore combinations of MCDM methods to answer the questions posed in the introduction of this work.

RESEARCH METHODOLOGY

The research can be considered descriptive, applied, and methodological. It encompasses the following steps: (i) bibliographic research and documentary research on the central themes of the research, by a systematic search in international databases such as Scopus, Web of Science, Science Direct and Google Scholar, covering the period from 1990 to 2016; (ii) development of a conceptual model for the measurement and evaluation of innovative capacity and innovation performance of SMEs, integrating two multicriteria decision support methods (AHP /

TOPSIS) and using linear regression analysis to identify the innovative capacity factors that most influence the innovation performance of SMEs; (iii) development of an empirical study with 30 SMEs, which participated in the NAGI Program of PUC-Rio (Brazil), aiming to demonstrate the applicability of this model; and (iv) proposition of indicators and metrics to measure and evaluate the innovative capacity and innovative performance of SMEs, associated with the dimensions covered by the proposed model.

THE MODEL FOR MEASURING INNOVATIVE CAPACITY AND INNOVATION PERFORMANCE OF SMEs

This section introduces the conceptual model proposed for measuring the innovative capacity and innovation performance of SMEs. Figure 1 shows the flow chart of the model in four phases.

Figure 1: Flow chart of the integrated fuzzy AHP-TOPSIS model for measuring innovative capacity and innovation performance of SMEs

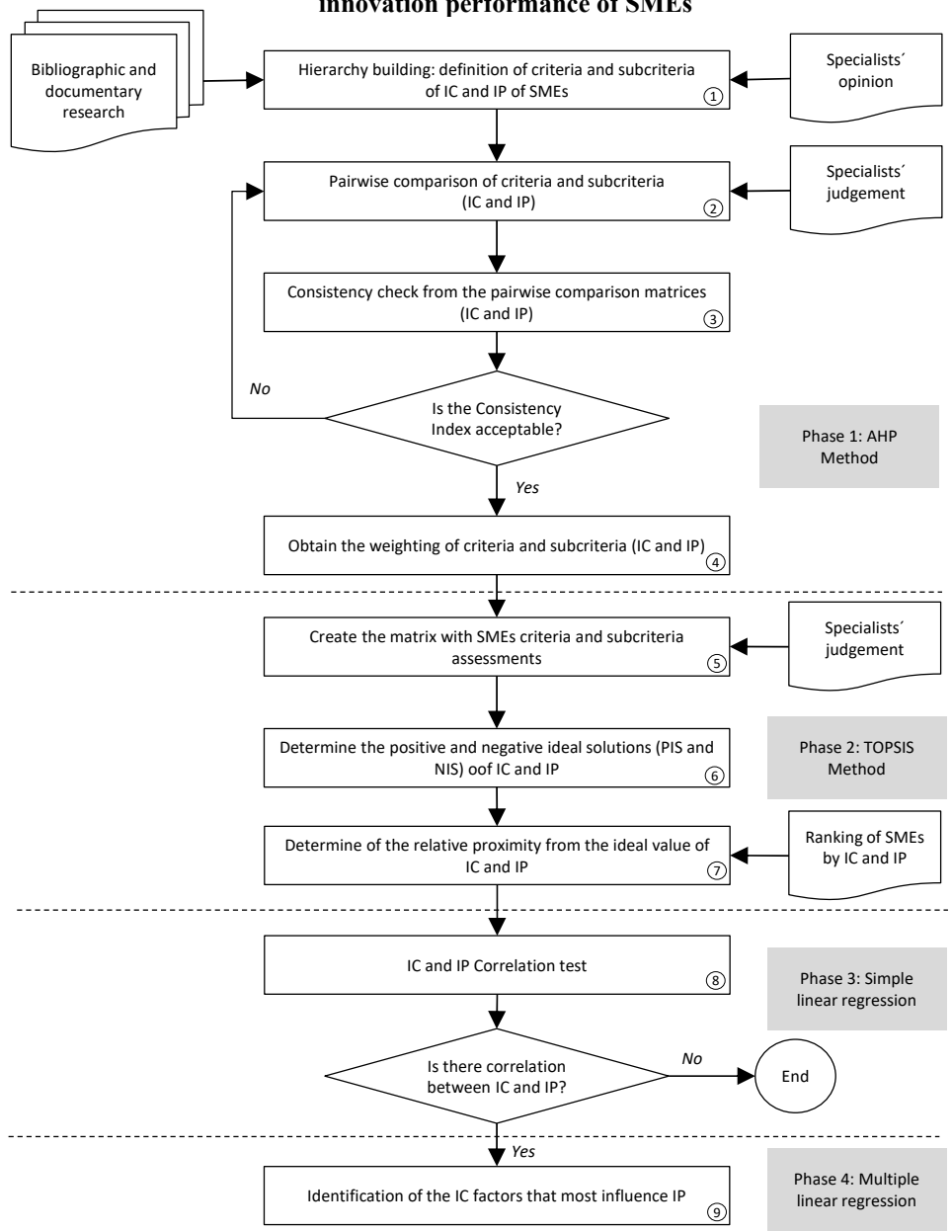

In the first phase, the AHP method is used for weighting criteria and sub-criteria concerning the assessment of the innovative capacity and innovation performance of SMEs. In the second, the TOPSIS method is employed for ranking SMEs by both indexes - innovative capacity and innovation performance. Further, simple linear regression analysis can evidence the positive correlation between innovative capacity and innovative performance in the context of SMEs. In the last phase, multiple linear regression analysis is used to identify the innovative capacity factors that most influence the innovation performance of SMEs.

MODEL VALIDATION

To demonstrate the effectiveness of the proposed model, we develop an empirical study covering 30 SMEs located in Brazil. These firms joined the third and fourth cycles of an Innovation Management Program supported by the Brazilian Innovation Agency (FINEP), a federal institution subordinated to the Ministry of Science, Technology, and Innovation (MCTI). This Program provides access to locally based, high-quality technology information and related services, helping firms to exploit their innovative potential and to create, protect, and manage their intellectual assets. For this research, we selected one of the projects of this Program – NAGI-PUC-Rio, which has been coordinated by the Pontifical Catholic University of Rio de Janeiro.

Data Collection and Analysis

For data collection, we designed a survey instrument with 50 questions, corresponding to a set of good practices for innovation management and performance, which were selected from the literature (Boly *et al.*, 2014; Enjolras *et al.*, 2014; Rejeb *et al.*, 2008; Sepulveda & Vasquez, 2014; and Doroodian *et al.*, 2014). These questions were grouped around four dimensions (criteria), and twelve themes (sub-criteria), as shown in Table 2.

Table 2: Structure of the survey instrument

Dimension	Theme	Questions
C1 - Governance and Organization	c11 – Leadership and culture	Q1 to Q9
	c12 – Strategy	Q10 to Q14
	c13 – Structure	Q15 to Q18
C2 - People	c21 – Human capital	Q19 to Q21
	c22 – Organizational competencies	Q22 to Q26
	c23 – External relationships and cooperation	Q27 to Q29
C3 - Processes	c31 – R,D&I management	Q30 to Q35
	c32 – Organizational learning and continuous improvement	Q36 to Q39
	c33 – Intellectual capital protection and economic appropriation of the RD&I efforts	Q40 to Q42
P1 – Innovation Performance	p11 – Product innovations	Q43
	p12 – Process innovations	Q44 to Q45
	p13 – Market impacts	Q46 to Q48
	p14 – Social-environmental impacts	Q49 to Q50
4 dimensions	13 themes	50 questions

The survey instrument was pre-tested by a small group of specialists in innovation management, and the process yielded a document that was judged to exhibit high content validity. The data collection was carried out in two stages: (i) self-assessment of the maturity level concerning the adoption of 42 innovation management practices; and (ii) self-assessment of the innovation performance level concerning the last three themes as shown in Table 2.

For the first step (self-assessment), the survey instrument was distributed among the 30 enterprises through email, and they have been asked to rate the maturity level concerning the adoption of each of the 42 good practices and the innovation performance level on a scale of 1 to 5. The inferior score being "1" (very low) and the superior score being "5" (very high). A total of 30 questionnaires with 100% response rate were used for data analysis.

During the analysis phase, the data were consolidated and evaluated by using the AHP-TOPSIS model (1st and 2nd phases of the model). The individual steps from the AHP matrices and the weighted vectors to the final ranking of SMEs (using TOPSIS) were implemented in Statistical Package for the Social Sciences (SPSS) to test to what extent the model can be integrated into the available standard software

Results from Phase 1: Use of AHP Method for Weighting Criteria and Sub-criteria

The first phase of the model aims to define the weights of the criteria and sub-criteria concerning IC and DI of SMEs, through of judgment of the specialists to create the pairwise comparison matrices.

Figure 2 shows the four matrices related to the innovative capacity: (i) criteria matrix; (ii) sub-criteria matrix of the criterion 'Governance and organization'; (iii) matrix of sub-criteria of the criterion 'People'; and (iv) the sub-criteria matrix of the 'Processes' criterion.

Figure 2: Pairwise comparison matrices of IC's criteria and sub-criteria

<p><i>Governance and Organization</i> $\begin{bmatrix} 1 & 3 & 6 \\ 1/3 & 1 & 3 \\ 1/6 & 1/3 & 1 \end{bmatrix}$</p> <p><i>People</i></p> <p><i>Processes</i></p> <p><i>Human Capital</i></p> <p><i>Organizational Competencies</i> $\begin{bmatrix} 1 & 5 & 2 \\ 1/5 & 1 & 5 \\ 1/2 & 1/5 & 1 \end{bmatrix}$</p> <p><i>External Relationships and Cooperation</i></p>	<p><i>Leadership and Culture</i> $\begin{bmatrix} 1 & 2 & 6 \\ 1/2 & 1 & 6 \\ 1/6 & 1/6 & 1 \end{bmatrix}$</p> <p><i>Strategy</i></p> <p><i>Structure</i></p> <p><i>R, D&I management</i></p> <p><i>Org. Learning and Cont. Improvement</i> $\begin{bmatrix} 1 & 2 & 7 \\ 1/2 & 1 & 9 \\ 1/7 & 1/9 & 1 \end{bmatrix}$</p> <p><i>Intellectual Capital Protection</i></p>
---	---

Figure 3 refers to the pairwise comparison matrix of IP's criteria.

Figure 3: Pairwise comparison matrix of IP's criteria

<i>Product innovations</i>	$\begin{bmatrix} 1,0 & 2,0 & 1/3 & 1/2 \\ 1/2 & 1,0 & 1/2 & 1/3 \\ 1/3 & 2,0 & 1,0 & 2,0 \\ 2,0 & 3,0 & 1/2 & 1,0 \end{bmatrix}$
<i>Process innovations</i>	
<i>Market impacts</i>	
<i>Social – environmental impacts</i>	

It should be noted that the pairwise comparison matrices were all consistent since their 'Consistency Ratios' were less than 0.1 (Saaty, 1980). Once the verification and validation of consistency were performed, the weights of the criteria and sub-criteria were generated. Table 3 presents the weights that will be adopted in the next phase of SME ranking, with the support of the TOPSIS method.

Table 3. Overall weights for criteria and sub-criteria by dimensions and themes of IC and IP of SMEs

IC's Dimension (Criteria)	Weights (DW)	Themes (Sub-criteria)	Weights (TW)	Overall (DW x TW)
Governance and Organization	0,6548	Leadership and culture	0,5675	0,3716
		Strategy	0,3575	0,2341
		Structure	0,0751	0,0492
People	0,2499	Human capital	0,3522	0,0880
		Organizational competencies	0,0887	0,0222
		External relationships and cooperation	0,5591	0,1397
Processes	0,0953	R, D&I management	0,3458	0,0330
		Organizational learning and improvement	0,5969	0,0569
		Intellectual capital protection	0,0572	0,0055

IP's Dimension (Criteria)	Weights (DW)	Themes (Sub-criteria)	Pesos (TW)	Peso Total (DW)
Product innovations	0,169	-	-	0,169
Process innovations	0,126	-	-	0,126
Market impacts	0,415	-	-	0,415
Social and environmental impacts	0,289	-	-	0,289

Results from Phase 1: Use of AHP Method for Weighting Criteria and Sub-criteria

During the phase 2, the matrices of innovative capacity and innovation performance were filled, already with the weights generated in Phase 1. This filling was carried out by the SMEs managers who judged the level of companies about each of the 50 questions, adopting a Likert scale. With the normalized data, calibrated with the weights, the Euclidean distances of the SMEs positions were calculated about the ideal positive (PIS) and negative (NIS) solutions. The last step refers to the ranking of SMEs about innovative capacity and innovation performance, as shown in Table 4.

Table 4: Ranking of SMEs by IC and IP indexes

Ranking of SMEs (IC)			Ranking of SMEs (IP)		
Enterprises	Distance (IIC)	Position	Enterprises	Distance (IIP)	Position
E26	0,88	1	E26	0,82	1
E11	0,85	2	E18	0,77	2
E18	0,78	3	E25	0,76	3
E1	0,68	4	E21	0,74	4
E16	0,6	5	E11	0,73	5
E5	0,58	6	E6	0,62	6
E3	0,56	7	E10	0,6	7
E19	0,52	8	E15	0,55	8
E7	0,52	9	E30	0,5	9
E15	0,52	10	E8	0,49	10
E25	0,52	11	E1	0,48	11
E8	0,49	12	E3	0,46	12
E21	0,49	13	E5	0,44	13
E30	0,47	14	E28	0,44	14
E23	0,43	15	E13	0,38	15
E22	0,42	16	E23	0,38	16
E10	0,41	17	E12	0,37	17
E20	0,39	18	E14	0,32	18
E4	0,38	19	E19	0,32	19
E28	0,38	20	E16	0,31	20
E6	0,38	21	E7	0,29	21
E13	0,35	22	E20	0,23	22
E17	0,34	23	E9	0,22	23
E9	0,34	24	E4	0,19	24
E12	0,32	25	E17	0,19	25
E2	0,31	26	E27	0,19	26
E24	0,3	27	E29	0,18	27
E14	0,25	28	E22	0,15	28
E27	0,15	29	E24	0,14	29
E29	0,14	30	E2	0,14	30

Figure 4 shows the values of the innovation performance indexes of the 30 SMEs are compared with the values of their innovative capacity indexes, leading to the hypothesis of a linear relationship between these indexes (IC index and IP index).

Figure 4: Comparison of IC and IP indexes of SMEs

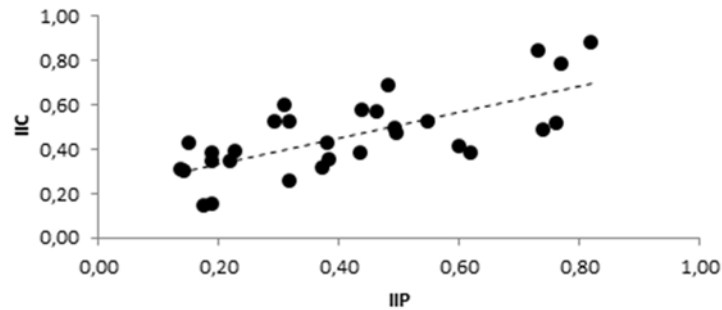

Results from Phase 3: use of Simple Linear Regression for testing the correlation between IC and IP indexes

To test the hypothesis of a linear relationship between the IC and IP indexes, a simple linear regression was performed. However, before estimating the line, using the Statistical Package for the Social Sciences (SPSS ®), the Kolmogorov-Smirnov and Shapiro-Wilk tests were done. In both, it was possible to affirm that IP index follows a Normal distribution at the significance level of 5%. In addition, it was necessary to carry out the Durbin-Watson test of residual independence, which indicated that these were independent.

To test the parameters and the validity of the hypothesis, a variance analysis (ANOVA) was performed. The results are presented in Table 5. It is important to note the high value of the correlation coefficient (r), which is equals 0.707. The adjusted line is given in equation (1) below:

$$\hat{y}_i = 0,29 + 0,839x_i; i = 1, 2, \dots, 30 \quad (1)$$

Table 5: Analysis of variance: simple linear regression

Model		Sum of Squares	df	Mean Square	F	Sig.
1	Regression	,645	1	,645	27,925	,000 ^a
	Residual	,647	28	,023		
	Total	1,292	29			

Results from Phase 4: use of Multiple Linear Regression for identifying IC factors that most influence IP of SMEs

Once confirmed the positive correlation between innovative capacity and innovation performance variables, we sought to identify which factors/themes of innovative capacity most influence the innovation performance of SMEs. For this, a multiple linear regression was made, having as response variable the innovation performance and how explanatory variables the nine factors/themes of innovative capacity (See Table 3). However, when the coefficients were estimated, it can be observed that not all of them contribute effectively to the innovation performance of SMEs.

From this observation, the Stepwise multiple linear regression method was chosen to be considered, regarding only the sub-criteria in order of importance and selecting those that contribute to improve the innovation performance of the focused SMEs. The model that best responds to the IP index is presented in Table 6.

Table 6: Parameters of the multiple linear regression model estimated by Stepwise

Model	Unstandardized Coefficients		Standardized Coefficients	t	Sig.	95,0% Confidence Interval for B	
	B	Std. Error	Beta			Lower Bound	Upper Bound
1 (Constant)	-,142	,114		-1,244	,224	-,376	,092
SC1	,184	,037	,688	5,019	,000	,109	,259

The multiple linear regression method by Stepwise indicates the factor/theme "Leadership and Culture" as the one that most influences the innovation performance of the focused SMEs. The other factors/themes were excluded, resulting in the estimated line, according to the equation (2):

$$\hat{y}_i = -0,142 + 0,184x_{1i}; i = 1, 2, \dots, 30 \quad (2)$$

CONCLUDING REMARKS

In this paper, an attempt was made to demonstrate in practice the benefits of adopting an AHP-TOPSIS approach to measure and evaluate the innovative capacity and the innovation performance of a group of 30 SMEs in Brazil. The main result of this research is to present a methodological perspective that considers the AHP-TOPSIS as an alternative model that considers complexity and multidisciplinary as characteristics inherent to this research theme. The adoption of the proposed model allows these companies to self-assessment, individually, and comparison with their competitors at the local, regional, national, or sectoral level.

As the main conclusion, it can be said that the AHP-TOPSIS model has fulfilled expectations and assumptions of this research by providing a more effective, and systematic decision support tool for decision makers to evaluate the innovative capacity *vis-a-vis* innovation performance of SMEs, regardless of the business sector in which they operate. The empirical study supports the claim that hybrid MCDA models provide an important methodological approach for tackling the focused problem.

The results of the empirical study covering 30 SMEs participating in the NAGI-PUC-Rio Program could demonstrate in practice the applicability of the proposed model in the context of the focused SMEs. These results evidenced the following differentials of the proposed model in relation to current practices reported in the literature: (i) a construction of composite indicators and indices of innovative capacity and innovation performance, which express the reality of smaller firms, considering their managerial specificities; and (ii) the integration of two multiple-criteria decision making (MCDM) methods, combined with simple and multiple linear regression analysis.

REFERENCES

- Adams, R., Bessant, J., & Phelps, R. (2006). Innovation Management Measurement: a review. *International Journal of Management Reviews*, 8 (1), 21–47.
- Armbruster, H., Bikfalvib, A., Kinkela, S., & Laya, G. (2008). Organizational Innovation: The Challenge of Measuring Non-Technical Innovation in Large-scale Surveys. *Technovation*, 28, 644–657.
- Barney, J. B. (1991). Firm resources and sustainable competitive advantage. *Journal of Management*, 17, 99-120.
- Biggs, T., Shah, M., & Srivastava, P. (1995). *Technological Capabilities and Learning in African Enterprises*. Technical Paper, Washington: World Bank, v. 288.

- Boly, V., Morel, L., Assielou, N. G., & Camargo, M. (2014). Evaluating innovative processes in French firms: methodological proposition for firm innovation capacity evaluation. *Research Policy*, 43, 608-622.
- Cetindamar, D., Phaal, R., & Prostre, D. (2009). Understanding technology management as a dynamics capability: a framework for technology management activities. *Technovation*, 29, 237- 246.
- Chaudhry, B., & Verma, P. K. (2016). Technological innovation capabilities: a critical review. *IJLTEMAS*, V (IV), 85-101.
- Chiesa, V., Coughlan, P., & Voss, C. A. (1996). Development of a technical innovation audit. *Journal of Product Innovation Management*, 13, 105–136.
- Doroodian, M., Rahman, M. N. A., Kamarulzaman, Y., & Muhamad, N. (2014). Designing and validating a model for measuring innovation capacity construct. *Advances in Decision Sciences*, 2014, 1-11.
- Enjolras, M., Galvez, D., Camargo, M., & Morel, L. (2014). Proposal of a methodology to elicit maturity curves: application to innovation and protection capabilities of SMEs. Lorraine: L’Institut National Polytechnique de Lorraine.
- Escribá-Esteve, A., Sánchez-Peinado, L., & Sánchez-Peinado, E. (2009). The influence of top management teams in the strategic orientation and performance of small and medium sized enterprises. *British Journal of Management*, 20, 581-597.
- Eunni, R. V., Brush, C. G., & Kasuganti, R. R. (2007). SMEs in emerging markets - an overview. *International Journal of Emerging Markets*, 2 (2), 22-37.
- Forsman, H. (2011). Innovation capacity and innovation development in small enterprises. A comparison between the manufacturing and service sectors. *Research Policy*, 40 (5), 739–750.
- Freeman, C. (2004). The national system of innovation in historical perspective. *Revista Brasileira de Inovação*, 3 (1), 9-34.
- Galvez, D., Camargo, M., Rodriguez, J., & Morel, L. (2013). PII - Potential Innovation Index: a tool to benchmark innovation capabilities in international context. *Journal of Technology Management & Innovation*, 8 (4), 36-45.
- Garcia-Muina, F.E., & Navas-Lopez, J.E. (2007). Explaining and measuring success in new business: the effect of technological capabilities on firm results. *Technovation*, 27 (1-2), 30-46.
- Guan J. C., & Ma, N. (2003). Innovative capability and export performance of Chinese Firms. *Technovation*, 23 (9), 737-747.
- Guan, J. C., Yam, R. C. M., Mok, C. K., & Ma, N. (2006). A study of the relationship between competitiveness and technological innovation capability based on DEA models. *European Journal of Operational Research*, 170 (3), 971-986.
- Guan, J.C., & Chen, K. (2010). Measuring the innovation production process: a cross-region empirical study of China’s high-tech innovations. *Technovation*, 30, 348-358.
- Hwang, C. L., & Yoon, K. (1981). *Multiple attribute decision making: methods and applications*. New York: Springer-Verlag.
- International Labour Organization (ILO) (2014). *Policies for the formalization of micro and small enterprises in Brazil*. São Paulo: ILO.

- Kong, F., Zhang, Z., & Liu, Y. (2008). Study on the evaluation of technological innovation capability under uncertainty. In: The 4th International Conference on Wireless Communications, Networking and Mobile Computing, pp. 1-4. Dalian, China: IEEE.
- Kuan, M.-J., & Chen, Y.M. (2001). A hybrid MCDM framework combined with DEMATEL based ANP to evaluate enterprise technological innovation capabilities assessment. *Decision Science Letters*, 3 (4), 491-502.
- Lawson, B., & Samson, D. (2001). Developing innovation capabilities in organizations: a dynamic capabilities approach. *International Journal of Innovation Management*, 5 (3), 377-400.
- Lin, Y.-H., Tseng, M.-L., Cheng, Y.-L., Chiu, A. S. F., & Geng, Y. (2013). Performance evaluation of technological innovation capabilities in uncertainty. *Academic Journals*, 8 (13), 501-514.
- Nelson, R.R., & Winter, S.G. (1982). *An evolutionary theory of economic change*. Cambridge MA: Belknap Press of Harvard University Press.
- Nemery, P., Ishizaka, A., Camargo, M., & Morel, L. (2012). Enriching descriptive information in ranking and sorting problems with visualizations techniques. *Journal of Modelling in Management*, 7 (2), 130-147.
- Organisation for Economic Co-Operation and Development. OECD (2009). *Innovation in Firms: a microeconomic perspective*. Paris: OECD.
- Organisation for Economic Co-Operation and Development. OECD (2005). *Oslo Manual: guidelines for collecting and interpreting innovation data*, 3rd ed. Paris: OECD.
- Organisation for Economic Co-Operation and Development. OECD (2010). *Measuring innovation: a new perspective*. Paris: OECD.
- Organisation for Economic Co-Operation and Development. OECD (2016). *Enterprises by business size*. Available in: <https://data.oecd.org/entrepreneur/enterprises-by-business-size.htm>. Accessed: 31 May 2017.
- Panda, H., & Ramanathan, K. (1996). Technological capability assessment of a firm in the electricity sector. *Technovation*, 16 (10), 561-588.
- Perez, C. (2004). Technological revolutions, paradigm shifts and socio-institutional change. In: E. Reinert (Ed.) *Globalization, economic development, and inequality: an alternative perspective*, pp. 217-242. Cheltenham: Edward Elgar.
- Ran, R. e Wang, B.-J. (2015). Combining grey relational analysis and TOPSIS concepts for evaluating the technical innovation capability of high technology enterprises with fuzzy information. *Journal of Intelligent and Fuzzy Systems*, 29 (4), 1301-1309.
- Rey, J. C. R. (2014). *Croissance, innovation et gestion dans les petites et moyennes entreprises industrielles du Nord-Ouest de l'Argentine: un modèle relationnel quantitatif*. Nancy, 2014. Thèse de doctorat en Génie des systèmes industriels. École Doctorale RP2E (Ressources, Procédés, Produits, Environnement), - Université de Lorraine.
- Romijn H., & Albaladejo, M. (2002). Determinants of innovation capability in small electronics and software firms in southeast England. *Research Policy*, 31 (7), 1053-1067.
- Rose, S.; Shipp, S.; Lal, B., & Stone, A. (2009). *Frameworks for measuring innovation: initial approaches*. Washington: Science and Technology Policy Institute.
- Roy, B. (1990). Decision-aid and decision-making. *European Journal of Operational Research*, 45 (2-3), 324-331.
- Saaty, T. L. (1991). *Método de análise hierárquica*. São Paulo: Mc - Graw Hill.

- Schumpeter, J. A. (1985). *Teoria do desenvolvimento econômico*, São Paulo: Nova Cultural. 15 Sebrae. Micro, pequenas e médias empresas. Available in: <http://www.sebrae.com.br/>. Accessed: 31 May 2017.
- Sepúlveda, J., & Vasquez, E. (2014). Multicriteria analysis for improving the innovation capability in small and medium enterprises in emerging countries. *American Journal of Industrial and Business Management*, 4, 199–208.
- Sepúlveda, J., Gonzalez, J., Alfaro, M., & Camargo, M. A. (2010). A metrics-based diagnosis tool for enhancing innovation capabilities in SMEs. *International Journal of Computers, Communications, and Control*, 5 (5), 919–928.
- Stone, A., Rose, S., Lal, B., & Shipp, S. (2008). *Measuring innovation and intangibles: a business perspective*, Washington: Institute for Defense Analysis.
- Szeto, E. (2000). Innovation capacity: working towards a mechanism for improving innovation within an interorganizational network. *The TQM Magazine*, 12 (2), 149 – 158.
- Teece, D. J. (2007). Explicating dynamic capabilities: the nature and microfoundations of (sustainable) enterprise performance. *Strategic Management Journal*, 28 (13), 1319-1350.
- Teece, D. J., Pisano, G., & Shuen, A. (2002). Dynamic capabilities and strategic management, In: G. Dosi, R.R. Nelson, S. G. Winter (Orgs.), *The nature and dynamics of organizational capabilities*, pp. 334-362, Oxford: UP.
- Tremblay, P. J. (1998). *Technological capability and productivity growth: an industrialized industrializing country comparison*. Montreal: Cirano.
- Tsai, M.T., Chuang, S.S., & Hsieh, W.P. (2008). Using analytic hierarchy process to evaluate organizational innovativeness in high-tech industry, In: *Annual Meeting (DSI)*, Baltimore, Maryland, USA, pp.1231–1236.
- United Nations. UN (2009). *Enhancing the innovative performance of firms: policy options and practical instruments*, Geneva: UN.
- Unsal, E., & Cetindamar, D. (2015). Technology management capability: definition and its measurement. *European International Journal of Science and Technology*, 4 (2), 181-196.
- Wang, C.-H., Lu, I.-Y., & Chen, C.-B. (2008). Evaluating firm technological innovation capability under uncertainty. *Technovation*, 28, 349–363.
- Wang, T. J., & Chang, L. (2011). The development of the enterprise innovation value diagnosis system with the use of systems engineering. In: *Proceedings of the International Conference of System Science and Engineering (ICSSE)*, 373–378.
- Yam, R.C.M., Guan, J. C., Pun, K. F., & Tang, E. P. Y. (2004). An audit of technological innovation capabilities in Chinese firms: some empirical findings in Beijing, China. *Research Policy*, 33 (8), 1123–1140.
- Yang, C., Zhang, Q., & Ding, S. (2015). An evaluation method for innovation capability based on uncertain linguistic variables. *Applied Mathematics and Computation*, 256, 160 –174.
- Zawislak, P. et al. (2012). Innovation capability: from technology development to transaction capability. *Journal of Technology Management & Innovation*, 7 (2), 14-26.
- Zhu, Y., Lei, H. (2012). Fuzzy AHP analysis on enterprises' independent innovation capability evaluation. *Physics Procedia*, 24, 1285-1291.

THE EFFECTS OF TRADE UNION SECURITY ARRANGEMENTS IN THE WORKPLACE: SOUTH AFRICAN PERSPECTIVE

Ndivhuho Tshisevhe
Tshwane University of Technology, South Africa

ABSTRACT

The Republic of South Africa ratified convention no: 87 of 1948 and no: 98 of 1949 of ILO. Section 23 of the Constitution of the Republic of South Africa guarantees to everyone the right to freedom of association. However, employee finds it difficult to exercise the right not join a union at a workplace where there is trade union security arrangements in place. Freedom of association in some countries such as Canada and Germany include the right not to associate, therefore a comparison with other countries such as UK, US and Canada will be made. This study intends to examine other ways in which employees may be allowed to exercise their right to freedom of association without any compulsory trade union membership. This study shall conduct a further research to find out if the South African Labour Relations Act (Act 66 of 1995) can be amended to an extent that employees are allowed to decide whether to join a trade union of their choice or not and also refuse to be party to trade union security arrangements.

Keywords: Freedom of associations, Trade union security arrangements, Right to join a union, Employees/workers, Trade union, Collective bargaining.

INTRODUCTION

In terms of Section 23 of the Constitution of the Republic of South Africa, every employer and every employee has the right to freedom of association. It is imperative to indicate at this stage that employees are compelled to join a trade union due to trade union security arrangements which are in place. This study intends to examine other ways in which employees may be allowed to exercise their right to freedom of association without any literal coercion. An employee who find himself in the workplace which has trade union security arrangements in place does not have a choice (especially if he is not a conscientious objector), it's either he join the union or face dismissal. The Labour Relations Act (LRA) guarantees the fundamental right to freedom of association. (Du Plessis, 2016, p 226) every employee has a right to take part in the formation of a trade union and to become a member thereof. On the other hand, every employer is equally allowed to form and become a member of employers' association. (Wedderburn, 1995, p 208) This right is guaranteed both nationally and internationally. In 1996, the Republic of South Africa ratified convention no: 87 of 1948 and no: 98 of 1949 of the International Labour Organization (ILO), these conventions are regarded as the cornerstone of the right to workers' freedom of association. The above conventions make it possible to promote and realize decent conditions at work. This right to freedom of association in some countries such Canada and Germany include the right not to associate. Freedom of association refers to the liberty a person possesses to enter into relationships with others for any and all purposes, for a momentary or long-term duration, by contract, consent, or acquiescence. (Alexander, 2008 p 8.) There is a freedom or right of association with other persons for the purpose of achieving some lawful goal. This is said to be the positive right or freedom. On the other hand the negative right is the right of non-association. (Landman, 1990, p 99) Strong and independent workers' and employers' organizations, and the effective recognition of their right to engage in collective bargaining, are major tools for labour market governance. Collective bargaining is a way of attaining beneficial and productive solutions to potentially conflictual relations between workers and employers. It provides a means of

building trust between the parties through negotiation and the articulation and satisfaction of the different interests of the negotiating partners. Collective bargaining plays this role by promoting peaceful, inclusive and democratic participation of representative workers' and employers' organizations. On the other hand, workers who agree to associate with each other for some purpose, by implication decline to associate with other persons maybe because they do not share the same values and ideologies. Pursuant to the above, it is clear that South African law does not allow employees to refrain from joining a union where there is union security arrangements in place. It is for this reason that the study shall conduct a research in an attempt to determine if the right to freedom of association cannot be exercised without any coercion. This being said the researcher is fully aware that the right to freedom of association is not absolute. Employees' should not be forced to join a trade union. The dignity of all workers is dependent on respect for their fundamental human rights at work: their rights to be fully involved in improving their wages and working conditions and in the success of the enterprises and industries in which they work. Only with full enjoyment of the rights to freedom of association and collective bargaining can workers, throughout the supply chain, shape their own future. It is therefore limited by the trade union security arrangements. (Van Jaarsveld and Van Eck, 2014, p 268) The right to freedom of association is limited in terms of section 36 of the Constitution of the Republic of South Africa. Trade union security agreement is a contractual agreement, usually part of a union collective bargaining agreement, in which an employer and a trade or labour union agree on the extent to which the union may compel employees to join the union, and/or whether the employer will collect dues, fees, and assessments on behalf of the union. (Nel, 1999, p 139) There are two reasons for union security arrangements. First, unions and their members argue that so-called 'free riders' should pay their own way. Secondly, the LRA's primary objectives are to promote a framework within which employees and their trade unions can collectively bargain in an orderly fashion, preferably on sectoral level. Union security agreements are one way of ensuring that all (or nearly all) workers incur the costs of collective bargaining (e.g., join the union and pay dues).

TRADE UNION SECURITY ARRANGEMENT IN OTHER COUNTRIES

A decision on whether to allow or not to allow union security arrangements is left in the hands of members' states. Union security agreements are explicitly mentioned in the labour laws of many countries, including the Republic of South Africa, the United States as well as in the United Kingdom. In comparison with other countries, union security arrangements are highly regulated by law and court rulings in the United States and to a lesser degree in the United Kingdom. In Canada, the legal status of the union security agreement varies from province to province and at federal level, with a few provinces permitting, but not requiring it, but the majority of provinces (and the federal government) requiring it if the union requests it. The choice of belonging to a union has parallel protection in English law to the right not to join. (Morris and Archer, 2000, p 160) In most Western European countries, the closed shop (one form of the union security agreement) is banned, while other forms go unregulated in labour law. But this is not a uniform conclusion, and law may vary widely. For example, in Germany both the right to join a union and the right *not* to join a union are equally protected by law and the courts, and all forms of union security agreements are banned. (Towers, 1998, p 168) The law in Belgium has similar provisions. Still, since participation in the unemployment insurance system is compulsory and only unions have the right to administer this system, union membership in Belgium remains high. Outside North America and Western Europe, the legal status of union security agreements varies even more widely. (Kearney, 2010, p76) In New Zealand, as of 1988, the closed shop was compulsory where a union organized the workplace. In the Philippines, various types of union security agreements are permitted under labour law. In Mexico, the closed shop was mandatory until the early 1990s, when a change in federal law permitted the union shop, agency shop, or no agreement at all. But because of the political ties between unions and the governing party in Mexico and other ways in which Mexican law favors established unions, the closed shop is essentially still the norm. (Potter, 1984, p 2) Many countries, however, have not addressed the issue of union security agreements. Neither Indonesian nor Thai labour law addresses the issue, and in both countries collective bargaining, union administrative procedures, and dues collection are so weak that the union security issues rarely arise. . (Shrinivas v Joshi and Kadu, 2013 p113) In Australia, the legal status of union security agreements has varied widely across each state, the national government and over time. Australian labour law does not explicitly regulate union security agreements. However, various forms of the union security agreement have been favoured at one time or another by each state, territory, or the national government, effectively regulating the favored type of union security agreement and disadvantaging its other forms. The right to freedom not to associate

is protected in several countries and closed shop agreement has been outlawed in many of them. (Olivier & Potgieter, 1994, p 444) For example, in Germany and Belgium, some forms of security arrangements have been interpreted as being contrary to the freedom of association, that freedom having been interpreted as being to include the freedom not to associate. (Fischl & Klare 2002, p360) In the UK and US they have been outlawed. On the other hand, Article 20 of the Universal Declaration of Human Rights provides that everyone has a right to freedom of peaceful assembly and association but article 20 (2) renders such right subject to the proviso that 'no one may be compelled to belong to an additional association. The right not to associate is also recognized by the ILO.

EFFECTS OF TRADE UNION SECURITY ARRANGEMENTS

Du Toit *et al* argued that when looking at what effects closed shop agreements have on the right to collective bargaining, it may be concluded that section 26 of the Labour Relations Act in a substantive sense reinforces rather than limits those rights to collective bargaining. What the author is trying to indicate is the fact that should it be found that the security arrangements are violating basic human rights, would one be able to justify such violation/limitation? On the other hand Landman argued that if freedom of association gains the upper hand over freedom of non-association in a new labour or constitutional dispensation, freedom of disassociation may become more important. For instance, if closed shops were to become the norm, one would expect to find, especially if the present protections were not retained, an assault on the union's right to disassociate itself from eligible members. Landman further argued that the freedom or right to disassociate is a necessary adjunct to the right to associate. In our country freedom of association gives way when it's in the public interest to do so. This is the case in a situation where the freedom or right would impinge on the rights of those with whom the union does not wish to associate. He also argued that a banned employee may be compelled to forfeit his freedom of association on economic grounds in the case of a closed shop. In return for this monopoly, the trade union has been obliged to sacrifice its freedom of disassociation.

According to Alexander, (Alexander 2008, p 8) freedom of association refers to a choice that an employee has regarding entering into a relationship with others in the work place for any and all purposes, for a monetary or long-term duration, by contract, consent, or acquiescence. In other words, this freedom should also include the freedom to refuse to enter into such relationships or to end any existing relationship, or to terminate them when not otherwise compelled. On the other hand, (Galles 2013 p26) Galles argued that in some countries unions' freedom of association means this freedom only exist when it comes to unions and doesn't apply to employees because unions will always be forcing employees and employers to associate with them, denying the latter their own freedom of association. A fundamental or inalienable human right must be one that everyone possesses. Furthermore if one person's exercise of a right prevents a second party's exercise of the same right, it is only a right for the first party, not a human right. If the second party is required to accept the first party's offer of association on the terms of the first party, the second party is not free to choose his associations. The second party therefore does not enjoy freedom of association. The upshot is that a fundamental right to freedom of association only means freedom to associate with those who also choose to associate with us. That requires people's freedom to refuse association with others against their will. However, Madima (Madima ,1993 p 4) believes that when employees are forced to associate with others it is what we call union security arrangements. In other words, when employees are forced to join a union that is where a union will derive its strength. Du Toit (Du Toit *et al* 2006 at 191) suggest that the effects of a closed shop agreement is to reinforce the collective bargaining rather than limiting it. If, on the other hand, it is found to be a limitation, the second question is whether it can be justified in terms of section 36 of the Constitution. Du Toit *et al* (2006) concurs with Madima (1993) and he believes that the only way to strengthen a union in the workplace is through union security arrangements and thus promoting collective bargaining, which will lead to better working conditions for all employees in the workplace. On the other hand, there are those who do not share Du Toit and Madima's view, Baird differs and argued that not all scholars agree that a free rider problem exists in labour relations. Baird *et al* (Baird, 1984, p12) indicated that it is every employee's responsibility to make sure that the working environment is conducive at all times. In other words, work conditions can be improved in many ways, not only through union membership. On the other hand, Madima argued that it is high time that everyone accepts that an individual employee does not have a guaranteed right not to associate in the employee relations sense. Madima further argued that an absolute right to refuse to belong to a trade union can only be guaranteed when it comes to political parties' membership. The right to refuse to belong to a union can only be exercised by three categories of bearers: who are conscientious objectors, the trade union itself and by workers in non-closed shop bargaining units.

Weeks argued that just as traditional laws fail to provide security to unions, these voluntary unionism laws do not and cannot eradicate compulsory unionism and provide individual no-unionists with real rights to obtain and retain employment. Weeks further argued that these voluntary unionism laws also work at another level. They are created to destroy or do away with closed shops in the workplace which will therefore leave unions powerless. According to Cordova and Ozaki, (Cordova & Ozaki, 1980, p 3) union security arrangement date back to 200 years ago and that was created as a result of a hostile environment, in order to survive. They further argued that some people questioned its compatibility with the right to work and freedom of association, whereas some alleged that it promotes trade union monopoly and as a result tend to kill small unions. Cordova and Ozaki are fully aware that these provisions impinges on the right to freedom of association in the workplace by forcing employees to associate with their enemies.

Other authors like Vettori (Vettori, 2003, p295) believes that South African legislation gives unions more powers than individual workers and currently it is no longer necessary. According to Parsley (Parsley, 1980, p17) compulsory membership clauses give trade unions powers to negotiate better wages and working conditions. This will benefit even those employees who are not members of the union and they should be compelled to contribute to the cost by being members of the union in a forceful manner. In as much as one will be swayed to support the views of Parsley CJ, the question still remains whether it is necessary to force an employee to support the cause of a union which is different to his, just for the sake of higher salary and benefits. I don't think that better salary and benefits are the only things that employees strive for in the workplace. Employees' freedom is equally important and should be respected at all costs. In supporting Parsley's view, Booth *et al* (Booth *et al* 2004, p. 407) said that when employees join a union, they do so in order to benefit and there are costs involved and the only way to force non-members is through providing benefits which will not be enjoyed, unless an employee is a member of a union. In terms of the law, union-covered members and non-members receive equal wages within the same workplace. According to Booth *et al*, a reason workers might join a union in the absence of coercion is that unions may offer excludable goods or services to their members to encourage them to join. I still find this view to be unfair because employees should be allowed to exercise their freedom without any interruption. They need to be free when making a decision. I therefore agree with Booth when they further argued that a trade union can exist without compulsory membership and union shop legislation and also that under certain conditions, economic incentive to "free ride" can be less than the economic incentive to join a large union, in the absence of compulsion. On the other hand, Morris argued that effective freedom is dependent upon the existence of a maximum of real alternatives. The fewer alternatives confronting the individual, the less free choice he has. Non-free societies are characterized by a minimum of alternatives: comply or else. A maximum of alternatives is the *sine qua non* of a free society. Compulsory union membership, in any form, restricts an individual employee's freedom of choice. Compulsory union membership violates the freedom of individual workers, strengthens the power of labour monopolies which already are so powerful as to represent a serious threat to a free society, and facilitates the exploitation of the consuming public by the more strongly organized union members.

QUESTIONS TO BE ANSWERED

This study addresses one question: 'Can the South African Labour Relations Act be amended to the extent that employees are allowed to decide whether to join a trade union of their choice or not to party to trade union security arrangements? This question is comprised of five (5) specific questions, namely;

- Which right is more important between the right to trade union security arrangements and the right to freedom of association? Can employees be allowed to make a choice of their own?
- Can the above proposition compromise/weaken the strength of a trade union in the workplace?
- Can South African trade unions be effective with trade union security arrangements which do not compel employee to join them but leave employees with a choice of whether to join a union or not? Is there no alternative to 'free riders', other than forcing them to join the union?
- Whether employees will be prepared to exercise their right not to associate.

- Can RSA afford to have the workers' right to freedom of association and trade union security arrangements at the same time without limiting each other?

Should the above questions be answered in the affirmative, then employees will exercise their right to freedom of association without any violation or limit due to trade union security arrangements because they will join a union out of their free will. Collective bargaining may also take place between an employer and a group of employees (non-union members) as well as union members. The question will be whether employees' power to bargain will not be compromised? It should be borne in mind that it is the prerogative of the employer to recognize a union or group of employees in the workplace, whether registered or not. It should be noted that a recognition agreement is a written statement of an employer's intention to recognize a trade union as a collective bargaining representative of its members. If this system of allowing employees who are not willing to join a union (or being excluded from agency shop agreement and closed shop agreement) succeed, it should mean that our legislation should also be amended to the extent that those employees are not allowed to benefit from the efforts of the union and employers negotiations. They should therefore be allowed to enter the negotiation table through their own structure, which will be recognized by the employer for collective bargaining purposes only. These will pave way for the right to freedom of association which will include the right not to associate because in South Africa this right is not exercisable. If this right is granted, employees are now going to weigh either to lose the benefits or to join a union of their choice. On the other hand, an employer can allow employees to group themselves for collective bargaining purposes and negotiate with him. Employees will not be forced by anyone/law to join the union but by the circumstances around them at the workplace and therefore will have the freedom of association which includes the right not to join. Trade union monopoly will be reduced and small unions will flourish. Trade union security arrangements laws in South Africa will then be amended and be structured in the manner that strengthen freedom of association rather than violate human rights, a move which is supported by the ILO.

CONCLUSION

The Republic of South Africa, unlike countries such as Germany, can adopt its own form of dealing with union security arrangement in a manner that does not force employees to join the union but may join due to the situation which they find themselves in. It is only then that the correct freedom of association shall be achieved because everyone will be truly free. This might even lead to a first in the world of labour law, it does not matter, as long as employees are happy and have a benefit of a true freedom of association, which is what is important. If one accepts an argument that closed shop agreement and agency shop agreement violate or contravene the freedom of association protected in our Constitution, in the LRA, and by the ILO, then there should be something that can be done about the situation by the legislature. However, at the moment in South Africa, such a move will be thwarted by the unions of which the majority support the ruling party, which is unlikely to antagonize its relationship with those unions. Another problem or the issue that I seek to research, is the impact of union security arrangements at hand which violates an individual employee's right to work and this can be replaced with a possible alternative which will guarantee a total protection of the freedom of association. This study will also attempt to answer some questions regarding over-protecting the unions in the workplace and not protecting individual employees. Most of the employees who are opposed to these security arrangements argue that their right to freedom of association is being impugned. Can an employer be compelled to enter into collective bargaining with employees who are not members of a trade union? In SA employees are forced to associate with unions which are affiliates to political parties and at times parties which employees do not support. The real freedom of association will be achieved only when workers are free from compulsory unionism. I concur with Kelly-Gagnon (Kelly-Gagnon 2013, p13) who argued that when union membership and dues are compulsory, workers are captives to their unions. Without having to earn workers' adherence or dues, unions have little incentive to represent their interests and end up spending collected dues on political and ideological activities. He further indicated that he is not pro-union, but neither is he anti-union or pro-business per se but rather pro-freedom. It is only when workers can join and remain in unions without any coercion whatsoever we can know for sure that unions are benefitting their members.

REFERENCES

Books

- Andrew Levy '*Rights at work: A Guide for Employees*' Juta Publishers 1st edition
- A Van Niekerk et al '*Law at work*' 1st edition, Lexis nexis publishers
- Creighton 'Freedom of association' in Blanpain (ed) *Comparative labour law and Industrial Relations in Industrialised market economies* 4th (1990) vol 2, Lexis nexis publishers
- D Du toit et al '*Labour Relations Law: A Comprehensive Guide*' 5th edition, Lexis Nexis Publishers.
- Du Toit et al *Labour relations law* (1995), Juta Publishers.
- D Ockert et al '*Essential Employment Discrimination Law*' 3rd edition, Cambridge Law journal .
- D du Toit, D Woolfrey, J Murphy, S Godfrey, D Bosch and S Christie *Labour Relations law* 3 edition (2000), Lexis nexis publishers
- Elias P and Ewing k '*Trade Union Democracy, Members' rights and the Law*, 1987, Blackwell publishers.
- Edward E Potter '*Freedom of Association, The Right to organise and Collective*' 1984, Labour policy association.
- Gillian S Morris and Timothy J Archer '*Collective Labour Law*' 2000, Hart publishers.
- Finnemore and Rhode van Rensburg '*Contemporary Labour Relations*' 2nd edition, Lexis nexis publishers.
- Frances Raday '*The decline of union power in: Joane Conaghan, Richard Freund's labour and law* 3 edition (1983) Oxford university publishers.
- Michal Fischl & Karl Klare (eds) '*Labour Law in the era of globalization*' (2002), Oxford University publishers.
- H Landis and L Grossett '*Employment and the law: A Practical guide for the workplace*' 2nd edition, Juta publishers.
- Industrial and Labor Relations Review*, Vol. 57, No. 3 (Apr., 2004) OECD publishers.

Articles

- A Landman '*Statutory inroads into a trade union's right of disassociation*' (1997) 18 ILJ 13
- A Landman '*Freedom of Association in South African Labour law*' (1990) Acta Juridica at 99.
- A Landman '*The Closed shop*' (1989) 2 Labour law briefs.
- A Landman's opposite conclusion in '*The closed shop born again*' 1995 Contemporary Labour Law 17
- Andrew Levy '*Rights at work: A Guide for Employees*' 1st ed p 78.
- Albertyn '*Freedom of association and the morality of the Closed shop*' (1989) 10 ILJ 981.
- Albertyn C '*The Closed Shop and Fairness*' (1991) 7 (4) Employment Law 74.

Alexander L 'What is freedom of association, and what is its denial' 2008 *Social Philosophy & Policy Foundation* at 8.

Alison et al 'Free Rider Problem and a Social Custom Model of Trade Union Membership' *The Quarterly Journal of Economics*, Vol. 100, No. 1 (Feb., 1985), at pp. 258

Alison et al 'The union Membership Wage-Premium Puzzle: Is There a Free Rider Problem?' Transaction Publishers, 1984.

Baird, Charles W 'Opportunity or Privilege: Labor Legislation in America'. New York: C. J. Backer (eds) *Managing Employment Relations in South Africa* (1999) para 5-49.

Budeli M 'Workers' right to freedom of association and Trade unionism in South Africa: An historical perspective, at 57, 2007.

Budeli M 'Freedom of Association for Public Sector employees' *Codicillus XLIV No/Nr 2*, p49

Budeli M "Understanding the right to freedom of Association at the workplace: Components and scope" *Obiter* 2010, p21.

Brenda Grant 'In defence of Majoritarianism: part 2- Majoritarianism and Freedom of Association'

Brian Towers 'A Handbook of Industrial Relations Practice: Practice and the law in the Employment relationship' 3rd ed p 168.

C Summers, 'Trade unions and their members' in L Gostin (ed), *Civil Liberties in Conflict* (London and New York: Routledge, 1988) 65.

Commission on Industrial Relations, United Kingdom: *Approved Closed shop agreements: British shipping federation/national union of seaman*. Report no. 30 (London HM Stationery Office, 1972),p.23.

Richard Kearney 'Labour Relations in the Public Sector' 4th ed p76.

D du Toit, D Woolfrey, J Murphy, S Godfrey, D Bosch and S Christie *Labour Relations law* 3 ed (2000) at 93-95;

D Du toit et al 'Labour Relations Law: A Comprehensive Guide' 5th ed p 191.

E. Cordova and M Ozaki 'Union Security Arrangements: an International overview' *ILR*, vol 119,no. 1 Jan-Feb 1980.

Frances Raday 'The decline of union power in: Joane Conaghan, Richard Michal Fischl & Karl Klare (eds) 'Labour Law in the era of globalization' (2002) at 360. 23.

Galles G 'Unions: Freedom of Coercive Association?' *The Freeman: FEE.org/Freeman* January/February 2013 at 26.

Harold M. Levinson et al 'Collective Bargaining and Technological change in American Transportation' p500.

James R. Moris 'Compulsory union membership and public policy' *Economic Outlook*, CIO, Jan.1950, at 75.

J. T. Addison / C. Schnabel, *The International Handbook of Trade Unions*,Cheltenham 2003: Edward Elgar, at p6.

Keith A . et al (1999) 'Trade union membership, tenure and the level of job insecurity', *Applied Economics*: at 127.

M Olivier & Potgieter '*The right to associate freely and the closed shop*. Part 1' 1994 Tydskrif vir die Suid Afrikaanse reg 289).

M Olivier & Potgieter '*The right to associate freely and the closed shop*'. Part 2' 1994 Tydskrif vir die Suid Afrikaanse reg 443 at 444

Madima T 'The Agency Shop' (1993) 9 Employment Law at 4.

Madima T '*Freedom of Association and the concept of compulsory trade union membership*'

Michel Kelly-Gagnon '*Union membership decreases when worker have a choice*' Toronto Sun, 8 February 2013.

Olivier "*Statutory Employment Relations in South Africa*" in Slabbert, Prinsloo, Swanepoel.

Olson, Mancur. '*The Logic of Collective Action: Public Goods and the Theory of Groups*'. 18th rev. ed. Cambridge, Mass.: Harvard University Press, 1971.

Parsley, "*Labor Union Effects on Wage Gains: A Survey of Recent Literature*," *Journal of Economic Literature*, Vol. 18, No. 1 (March 1980), pp. 1-31.

Parkert 'Freedom of association in R Blanpain Comparative Labour law and industrial relations 3 ed (1987) 173-195.

Phillipa Weeks '*Union Security Law: A study of Preference and Compulsory unionism*' 1990: 42.

Richard A. Lester, "*Some Reflections on the 'Labor Monopoly' Issue*," *Journal of Political Economy*, Dec. 1947, at 530.

Sheldon Leader '*Freedom of Association: A study in Labour Law and Political Theory*' p 146.

S Vettori '*The Labour Relations Act of 1995 and the protection of Trade unions*' at 295.

S Christensen et al '*The wage effect of compulsory union membership*' ILRR, Vol 36, no: 32,

The Controversy over trade union membership in the US', in international labour review, Feb. 1958, pp113-131.

Towers et al "*The Representation Gap: change and reform in the British and American Workplace*'. Oxford, England: Oxford University Press, 1997.

Ulman et al '*Labor and an integrated Europe*'. Washington DC: Brookings Institution Press, 1993.

V Mantouvalou 'Is there a human right not to be a trade union member'? Labour rights under the European Convention on human rights, LSE Law, society and economy working papers 08/2007. London school of Economics and political science, 2007) 2.

Von Pronzyski '*Freedom of Association and the Closed shop: the European perspective* (1982) 41 Cambridge Law journal 256.

White, '*Trade Unionism in a Liberal State*' (1998) 334-335.

8.3. Table Statutes and ILO Conventions

- 6.3.1. Basic Condition of Employment Act 75 of 1997
- 6.3.2. New Zealand, Employment Contracts Act of 1991
- 6.3.3. Labour Relations Act 66 of 1995
- 6.3.4. Employment Equity Act 55 of 1998
- 6.3.5. The Constitution of RSA Act 108 of 1996
- 6.3.6. Article 2 of the Convention Concerning Freedom of Association and protection of the right to Organize 87 of 1948
- 6.3.7. Article 11 of the European Convention on Human rights
- 6.3.8. ILO Convention 87 of 1948
- 6.3.9. Article 20 of the Universal Declaration of Human Rights

KEY INTELLIGENCE TOPICS OF SPORT COACHES: WHERE SHOULD THE FOCUS BE?

Liandi van den Berg
North West University, South Africa

ABSTRACT

Sport coaches, just as business managers, collect and analyse data to answer their informational needs and to counter opposition strategies. At present, little is known about coaches' intelligence needs and this study utilised the theoretical framework of a business competitive intelligence (CI) process model to explore this sport phenomenon. High-level cricket coaches participated in semi-structured interviews and a content analysis was performed using ATLAS.TI™ computer-assisted qualitative data analysis software. To assure data validity and reliability, the steps proposed by DeCuir-Gunby, Marshall and McCulloch (2011) in creating a codebook during the constant comparative content analysis was followed (Boeije, 2001). Interviews were coded inductively and categorised under Key Informational Topics (KITs). Cricket coaches identified KITs divided into three categories of information on i) opposition, ii) own team and iii) environment. The cricket coach KITs relate to the CI business domains' strategic, key player and early warning KIT categories. The findings of this study substantiate the application of the business CI process to a sport coaching context and business managers and CI professionals' knowledge and skills could be employed to educate and train sport coaches to identify more and specific competitor directed KITs. The value of this study may shift coaches' predominant focus of informational needs on own team to that of the opposition, enhancing their strategy countering abilities.

Keywords: Key intelligence topics, cricket coaches.

INTRODUCTION

Sport coaches perform similar activities as business managers in collecting and analysing data and information on competitors and their environment (Jones, 2002). Within the sport domain, coaches incorporate performance analysis (PA) as a process, whereby information is gathered and analysed, but this process aims mainly to improve their own team performance (Hughes & Bartlett, 2002), with only a small amount of time and resources aimed at competitor analysis (Hughes, 2005). In the business domain, managers focus tremendous effort on gaining knowledge on their competitors and utilise competitive intelligence (CI) processes to enhance their operations (Wright, Bisson, & Duffy, 2012). CI involves the systematic gathering, analysis and management of external information that affect an organisations' plans, decisions and operations (SCIP, 2012). In this regard business managers employ the first stage of data collection in the 4Cs CI process model (Weiss, 2002), and this study aims to demarcate the undefined data collection process of cricket coaches from the theoretical framework of a business CI process (Potrac, Jones, & Cushion, 2007). In the first step of the business data collection stage, managers identify key intelligence topics (KITs), which direct the collection process and are used to create intelligence for decision-making purposes (Bose, 2008; Fatti & Du Toit, 2013). The study explores the key intelligence topics of high-level cricket coaches since very little knowledge exists on their current informational needs (Partington & Cushion, 2013).

Key intelligence topics

The identification of the KITs at the onset of the CI process is of cardinal importance. KITs in the business realm represents a decision maker's information and intelligence needs in relation to an organisation's strategy; hence, it influences the type and quality of information collected (Garcia-Alsina, Ortoll, & Cobarsi-Morales, 2013), since it directs the focus of the collection process (Fleisher & Wright, 2010). KITs are divided into the categories of

strategic decisions and actions, early warning topics and a description of the key players (Weiss, 2002). Key player KITs usually involve the identification of opportunities, threats, strengths and weaknesses of competitors (Wright & Calof, 2006), while the early warning KITs category aim to eliminate surprises and tends to focus on the identification of possible threats (Weiss, 2002). The category of strategic decision type KITs refer to intelligence aimed at supporting own strategic decisions through the assessment of change within own team or the response to competitors (Weiss, 2002).

In the sport domain, coaches search for and use match and performance data, which is referred to as key performance indicators (KPI) (Petersen, Pyne, Portus, Cordy, & Dawson, 2008) and which is similar but not identical to key intelligence topics identified by managers within business. KPIs are only the means to address coaches' informational needs and little research is available that indicates which competitor information apart from KPIs coaches use to develop their team strategy (Wright, Atkins, & Jones, 2012). For this reason, there is a need to clarify the KITs that coaches use to direct data collection activities and develop their competitive strategy (Groom, Cushion, & Nelson, 2011).

METHOD AND PROCEDURE

This exploratory study is qualitative in nature and used semi-structured interviews to advance the properties of a specific phenomenon from a theoretical background (Henning, Van Rensburg, & Smit, 2004).

Participants

Purposeful and convenience sampling was utilised in this study as it was considered appropriate since the intension was to discover, understand and gain insight of a specific phenomenon (Merriam, 1998). This study focused on expert cricket coaches who are involved in CI related activities in order to gain understanding and acumen into coaches' key intelligence needs (Wright et al., 2012), since little research on such activities are available (Groom et al., 2011). Expert cricket coaches were identified according to one of the following criteria, namely the coach must have at least ten years of coaching experience or must have coached at university, provincial or national level (Côté, Salmela, Trudel, Baria, & Russell, 1995).

Interview schedule

A literature review on the available CI processes and models, as well as frequently used surveys were scrutinised to develop a preliminary interview schedule. The interview schedule contained six questions relating to the four steps of the CI process, namely data collection, conversion, communication and countering, as well as questions related to CI awareness, culture, planning, identification and focus (key intelligence topics) (Weiss, 2002). In order to finalise the interview schedule, intra-university peers were approached and asked to evaluate the schedule and provide feedback. For the purpose of this study, the interview data of the participants on the first stage of data collection and in particular their identified KITs were used.

Data collection

University, provincial and professional cricket coaches gave written consent, after which the researcher arranged a suitable date, time and venue for a face-to-face, telephonic or Skype interviews. Snowball sampling occurred and one group interview with four coaches took place with another interview including a coach and his assistant coach. All other interviews were performed individually. The researcher emailed the interview schedule to the participants at least two days in advance and with the onset of the interview, the researcher briefly explained the objectives of the interview. The researcher transcribed the voice recorded interviews verbatim and sent the typed interviews back to the participants for validation (Creswell, 2003). Coaches also completed a demographic questionnaire section.

Data analysis

The process proposed by DeCuir-Gunby, Marshall, and McCulloch (2011) was followed in creating a codebook as a critical first step and reference for analysing the interviews. A codebook is defined as: “a set of codes, definitions and examples used as a guide to help analyse interview data” (DeCuir-Gunby et al., 2011, p. 138). Codes entered in the ATLAS.TI™ system were generated from theory (theory-driven) through a systematic literature review (SLR) performed by the researcher (DeCuir-Gunby et al., 2011). A code is defined as “tags or labels for assigning units of meaning to the descriptive or inferential information compiled during a study” (DeCuir-Gunby et al., 2011, p. 137). The second step of the codebook development process involved the revision of the codes with a colleague researcher within the context of the data and led to the creation of data driven codes—a second manner by which codes may be created (DeCuir-Gunby et al., 2011). Data driven codes were created by reducing the raw data into smaller units such as codes (DeCuir-Gunby et al., 2011). A further discussion on the appropriateness, definition and example of all codes (DeCuir-Gunby et al., 2011) followed between the researcher and a senior colleague with experience in qualitative research methods. Definite care was taken in creating specific codes, and the researchers had to ensure that definitions were precise, encompassing the constructs and that example quotes illustrated each code appropriately (DeCuir-Gunby et al., 2011). The third step in the codebook creation involved determining the reliability of the coding procedure (DeCuir-Gunby et al., 2011) by calculating of a Cohen’s Kappa. Cohen’s Kappa is a change-corrected measure of inter- and intra-rater reliability (Anderson, Rourke, Garrison, & Archer, 2001). The intra- and inter-rater reliability for this study was both calculated at $\kappa = 0.8$. This substantial agreement indicated the consistency in creating and applying codes by the researcher and validated the qualitative method used (Campbell, Quincy, Osserman, & Pedersen, 2013; DeCuir-Gunby et al., 2011). The qualitative analysis was performed through constant comparative analysis (CCA), whereby the researcher simultaneously analysed the content in applying the code book and codes to the data, together with data collection through interviews (Boeije, 2002; Henning et al., 2004). The CCA was performed until data saturation was reached and the researchers unequivocally determined that no additional data are being found that could develop new codes or categories (Guest, Bunce, & Johnson, 2006). For the purpose of this study, the researcher included and discussed those codes that were considered under the theme of data collection and specific to the key intelligence topics, which are presented in Table 3.

RESULTS

Fourteen male cricket coaches who matched the inclusion criteria participated in the semi-structured interviews, of which twelve were head coaches with two assistant coaches. Three coaches had between six and nine years coaching experience; nine coaches between ten to nineteen years; and two coaches more than twenty years’ experience.

Table 1: Demographic information of cricket coaches and support staff

N	Gender		Position		Experience (years)		
	Male	Female	Coach	Assistant coach	6-9	10-19	20+
14	14	0	12	2	3	9	2

Six coaches coached at professional franchise level, with one coach at national level, four at provincial, two at premier league and one at university level. The participants mainly coached male teams; with two coaches who coached both genders. One participant coached a female team.

Table 2: Team involvement and coaching level information

	Current team level coaching / involvement					Present team coaching / involved gender	
	University team	Premier league	Provincial team	Franchise level	National side	Male	Female
n	1	2	4	6	1	13	3

Codes associated with the KITs category of cricket coaches' informational needs are presented in Table 3.

Table 3: Codes from cricket coach interviews: Key intelligence topics

Code and coach quotation	Category
Key Intelligence Topics	KITs aspects
And then you will also try and gather information on like the brand of cricket they play and then implement it like that and try and execute with your skills (P8a)	Brand of cricket
...That is why I think it is vitally important to have a thorough knowledge of your own players before you go to the competitors because you then know, ok this is plan A and it didn't go according (P8b)	Own team knowledge
What I want on opposition is about their character. Where can I find the soft areas, because I don't think high level sport is only about technique, it is more about the character and we talk about mental strength and all of those things. So where can I find a soft underbelly. If I can find out everything about a particular player, in terms of what makes him tick, what gets him going, what does he enjoy and what does he not enjoy (P8c)	Opposing team character, mental aspects
...as I said in cricket you can get bogged down by so much information, that you have to pick out what is key (P17a)	Identify most important aspects
There are a couple of things; the first thing would be conditions...and then obviously you have to look at team selection, what sort of players you want to go in with. We then also have to look at the experience of their team as well. Sometimes there are more experienced players, and there are certain players that you try and get out, you know which are the key players and obviously have a certain game plan for that as well, so that goes into specifics...and then we will go and look at each player (P17b)	Conditions, team selection, experience, game plan
The benchmarks are what you need, what is a winning score, a first innings score. So we know in the first innings we are going to need 350 to win the game in the fourth day. So we will set out goals for each partnership to try and reach our desired target (P16a)	Benchmarks of success for own team
I will look at strengths and weaknesses (P14)	Opposing team strengths and weaknesses
So, this is their line-up, this is their problem, this is how we are planning of getting these guys out, and this is where their strengths and their weaknesses are. These are our plans (P2)	Opposing team line-up, own strategy
Some grounds you can score a lot of runs, some grounds you can't score a lot of runs, so you have to come to a point to know exactly what a good score is and what you can do (P3a)	Runs scored on grounds
This is where cricket can be very complex, because there are things you need to look at as a team when you play a certain opposition (P3b)	Team aspects, certain opposition
Code and coach quotation	Category
Key Intelligence Topics	KITs aspects
Basically the biggest thing that I was looking for me was how they get out...on average are they bowled, or are they caught on the boundary, or are they run out or what. So I was looking for that. The other biggest things, is I was looking for the fours and sixes. (P9a)	Opposition dismissals, areas runs are scored
So now you have to come and say—what we know about these Sri Lankans is that they can be impatient, they love hitting boundaries, they want to play the game at a certain rate. They don't like facing dot balls, you know those sorts of things (P8d)	How opposition like to play
...so I see in certain conditions they are not comfortable (P8e)	Uncomfortable conditions
With our teams where we basically sit down and have a look at the 12 or 13 possible players that we are going to be facing (P9b)	Possible opposition
The biggest thing for me in T20 cricket is where players do get under pressure and what do they normally do when they get under pressure (P9c)	Handling pressure
The key things for me are: the first one – let's say it is a home game or like we are playing away, is my communication with the grounds man. (P9d)	Home or away game – grounds

	man
I also check if the team that we are playing against has won games before, like are they under pressure, is the coach under pressure, is there drama you know like in their side (P9e)	Opposing team stats and overall functioning
You get to know their fears, theirs strengths and weaknesses, their opportunities and threats, so I think it is important that when they come that we get that info from those players just to get the edge. They may know something I don't know, because the player can come to me and say coach, I was with this guy in Australia, he prepares like this, and he looks to do this and that, so I have more info on that certain player then I can share it with my team. You don't get this info anywhere, it is close and personal (P9f)	Fears, SWOT analysis
As far as opposition is concerned I would go through each one of my particular weapons that I have at my disposal and we might even strategise to the extend to team selection will depend on where we play and the wicket we play on and sometimes opposition (P10)	Own payer or team "weapons"
I think one is to have an idea what their team will look like, so you will have a strong idea of your game plan, you need to know who you are playing against, two is the conditions...and what the strength of your group is (P11)	Opposing team to influence own game plan, conditions, own strengths
You first look who you are playing against, where you are playing and the history of the field. What is a typical score on that field...the first thing is I make sure my players are on level and then I look at the opposition, but if I know the opposing team has 3 left hand bowlers in their team, I will take an extra off spinner... (P13a)	Opposition team, venue, history of matches on venue
This players' release shot is this, so you want to build pressure and then you know he is going to release with that shot... (P13b)	Players outlet from pressure
Yes, what happens is because of such back to back games, you can anticipate from the last game, this is the possibility of their team, yes, it is just doing your homework in terms of they are playing back at home now, they are probably going to play their best bowling attack (P16b)	Anticipation of opposing team selected

The coaches' responses to the key topics they would want information about included numerous aspects – from information on their own team (P8b, P10, P3a, P16a) to the opposition team (P8c, P14, P2, P9a, P11, P13a) and conditions (P13a, P11, P9d, P8e, P3a, P17b). Key information topics on their own team included own players available to select a team and the experience of the players in order for the coach to devise a game plan (P8b, P17b). Coaches also want information regarding specific benchmarks on how their team would structure their team approach (P16a). Coaches need information on their own team and players' strengths (P11) and "weapons" (P10), mainly to strategise and devise a game plan (P10, P17b). Regarding information on the opposition, coaches looked at the type or "brand of cricket" that the opposing team plays (P8a), their character, mental strengths or a "soft underbelly" (P8c). General strengths and weaknesses of opposing teams (P14), their possible team line-up (P9b, P2), how they like to play their type of cricket (P8d), dismissals of batsmen and areas on the ground where opposition players' score runs (P9a) are also information needs identified by the cricket coaches. Coaches looked at how the opposition players handle pressure (P9c), at match and performance statistics over a period of time, as well as any conflict within the opposition team (P9e). Specific individual aspects such as opposition players' fears and threats, as well as opportunities to counter opposition threats were mentioned as KITs (P9f). The opposition team's specific players to compete in the match is unknown to the coach until very close to the commencement of the match, which is an aspect of great interest to coaches (P16b, P13a, P11, P9b, P2). As soon as coaches receive the details on the opposition teams' selection, they formulate or enhance their own strategy (P2) and game plan (P11, P13a). Coaches identified opposition players' outlet shot they often used to release match pressure as a key information aspect and area of possible exploitation (P13b). In most situations, coaches only anticipate the players that will be included in the opposing team and plan according (P16b). A home or away game greatly influenced the coach's planning and decisions (P9d) since the venue, the history of matches, runs scored (P3a) and match results on that pitch also need consideration by coaches in planning and preparing for competitions (P13a). The conditions at a venue has the potential to create certain challenges for opposition teams (P8e) and information on the recent overall performance of the opposing team as well as their team dynamics (P9e) are deemed valuable information. With numerous variables influencing opposition and own team selection and performance, coaches realise that their decision making

is at individual player level as well as for the team (P3b). It is immensely important that coaches learn to discern which information topics they should pay attention to (P17a).

DISCUSSION

The categories of KITs identified by this study's cricket coaches can be summarised into the following topics, namely information on (i) competitors, (ii) own team and (iii) playing conditions. Information needs regarding competitors are similar to the business defined *key player KITs* aimed at understanding a key player better in order to devise a counter strategy (Weiss, 2002). Coaches' KITs such as *how the opposition like to play* or *the brand of cricket they play*, are unmeasurable and, therefore, not included in usual data collection and performance analysis processes, and not documented within a data base as required within the CI collection process (Priporas, Gatsoris, & Zacharis, 2005). With inadequate documentation and an insubstantial analysis on certain key intelligence topics, it also seems as if participant coaches operate from their memory or from a gut feeling regarding key player competitor information (Wright, Atkins, et al., 2012; Wright, Bisson, et al., 2012). Coaches should learn to use their KITs to direct a proper data collection process with the purpose to make strategic decisions. Decisions made on the assumptions by the decision maker and not on substantial and verified competitor and key player information, counters the very essence of the purpose of CI which is to be used for informed decision making (Du Toit & Sewdass, 2014).

KITs identified and related to own team information are similar to the business-related *strategic type of KITs*, since it is often the most tangible measure of intelligence success achieved (Weiss, 2002). Since this type of KITs refer to own organisational strategic decisions, coaches use the information on their own team strengths and weaknesses to make decisions regarding team selection and to devise a game plan (Wright, Atkins, et al., 2012). Within this type of KIT, it is remarkable that none of the high level coaches indicated injuries of own players as an influential informational need, since injuries could impact own player selection, batting order and team strategy (Orchard, James, Kountouris, & Portus, 2010; Ranson, Hurley, Rugless, Mansingh, & Cole, 2013). Coaches mainly use own team information to focus on and measure own players' improvements, since it indicates the successful implementation of the coaching process, whereby coaches need to enhance technical, tactical and effort capabilities of his own players (Wright, Atkins, et al., 2012).

The business CI *early warning KITs* category centre around the elimination of surprises or threats by analysing changes in the environment (Weiss, 2002). In this regard, cricket coaches identified a similar category KIT related to the conditions of the stadium or grounds where their team will have to compete. Aspects such as the history, runs scored and venue particulars could be classified within this category, since it has the potential to change due to weather conditions or the manner in which the pitch is prepared. Another cricket specific identified KIT that could be placed into this category is the unknown opposition team members who will be selected to compete against their own team. Coaches repeatedly indicated that their decision making, game plan development and own team selection often resides on the availability of information regarding specific opposition team members. The need to manage surprises regarding opposition team member inclusions is most apparent and current and future research on measurable constructs and KPIs could aid coaches to predict the opposition team more successfully (Petersen, Pyne, Portus, & Dawson, 2008).

CONCLUSION

The high-level cricket coaches included in this study exhibited specific key intelligence topics that are important for competitive intelligence creation and utilisation. Intelligence operations' success depends on how well the information needs of the intelligence user may be met and, therefore, the intelligence creation process should be executed in such a way that the organisation makes decisions and acts on the resulting intelligence. The coaches' identified KITs seem to focus a lot of attention on their own team performance improvement with additional interests in competitor information and little on the playing environment and conditions. Findings of this study substantiate the application of the business CI process to a sport coaching context and business managers and CI professionals' knowledge and skills could be employed to educate and train sport coaches to identify more and

specific competitor directed KITs. The competitor KITs should be used to direct coaches' opponent information gathering and analysis process, resulting in true competitive intelligence creation and counter strategy decision making. The CI business domain could aid in the application and development of a new niche research area within the sport domain.

REFERENCES

- Anderson, T., Rourke, L., Garrison, D. R., & Archer, W. (2001). Assessing teaching presence in a computer conferencing context. *Journal of Asynchronous Learning Networks*, 5(2).
- Boeije, H. (2002). A purposeful approach to the constant comparative method in the analysis of qualitative interviews. *Quantity and Quality*, 36, 391-409.
- Bose, R. (2008). Competitive intelligence process and tools for intelligence analysis. *Industrial management & data systems*, 108(4), 510-528.
- Campbell, J. L., Quincy, C., Osserman, J., & Pedersen, O. K. (2013). Coding In-depth Semistructured Interviews: Problems of Unitization and Intercoder Reliability and Agreement. *Sociological Methods & Research*, 42(3), 294-320.
- Côté, J., Salmela, J., Trudel, P., Baria, A., & Russell, S. (1995). The coaching model: A grounded assessment of expert gymnastics coaches' knowledge. *Journal of Sport and Exercise Psychology*, 17(1), 1-17.
- Creswell, J. W. (2003). *Research Design. Qualitative, quantitative and mixed methods approaches* (2nd ed.). Thousand Oaks, California: Sage.
- DeCuir-Gunby, J. T., Marshall, P. L., & McCulloch, A. W. (2011). Developing and Using a Codebook for the Analysis of Interview Data: An Example from a Professional Development Research Project. *Field Methods*, 23(2), 136-155.
- Du Toit, A. S. A., & Sewdass, N. (2014). Competitive Intelligence (CI) in Morocco. *African journal of library archives and information*, 24(1), 3-13.
- Fatti, A., & Du Toit, A. S. A. (2013). Competitive intelligence challenges faced by South African pharmaceutical companies. *Asia Pacific Journal of Business and Management*, 4(1), 39-54.
- Fleisher, C. S., & Wright, S. (2010). Competitive Intelligence analysis failure: diagnosing individual level causes and implementing organisational level remedies. *Journal of Strategic Marketing*, 18(7), 553-572.
- Garcia-Alsina, M., Ortoll, E., & Cobarsí-Morales, J. (2013). Enabler and inhibitor factors influencing competitive intelligence practices. *Aslib Proceedings*, 65(3), 262-288.
- Groom, R., Cushion, C., & Nelson, L. (2011). The delivery of video-based performance analysis by England youth soccer coaches: towards a Grounded Theory. *Journal of Applied Sport Psychology*, 23, 16-32.
- Guest, G., Bunce, A., & Johnson, L. (2006). "How many interviews are enough? An experiment with data saturation and variability". *Field Methods*, 18(1), 59-82.
- Henning, E., Van Rensburg, W., & Smit, B. (2004). *Finding your way in qualitative research*. Paarl: Van Schaik.
- Hughes, M. (2005). Notational analysis - a mathematical perspective. *International Journal of Performance Analysis in Sport*, 4(2), 97-139.

- Hughes, M. D., & Bartlett, R. M. (2002). The use of performance indicators in performance analysis. *Journal of Sport Sciences*, 20(10), 739-754.
- Jones, G. (2002). Performance Excellence: A Personal Perspective on the Link Between Sport and Business. *Journal of Applied Sport Psychology*, 14(4), 268-281.
- Merriam, S. B. (1998). *Case study research in education: A qualitative approach*. San Francisco, CA: Jossey-Bass.
- Orchard, J., James, J., Kountouris, A., & Portus, M. (2010). Changes to injury profile (and recommended cricket injury definitions) based on the increased frequency of Twenty20 cricket matches. *Open Access Journal of Sports Medicine*, 1, 63-76.
- Partington, M., & Cushion, C. (2013). An investigation of the practice activities and coaching behaviors of professional top-level youth soccer coaches. *Scandinavian Journal of Medicine and Science in Sports*, 23, 374-382.
- Petersen, C., Pyne, D., Portus, M., & Dawson, B. (2008). Analysis of Twenty/20 Cricket performance during the 2008 Indian Premier League. *International Journal of Performance Analysis in Sport*, 8(3), 63-69.
- Petersen, C., Pyne, D. B., Portus, M. R., Cordy, J., & Dawson, B. (2008). Analysis of performance at the 2007 Cricket World Cup. *International Journal of Performance Analysis in Sport*, 8(1), 1-8.
- Potrac, P., Jones, R., & Cushion, C. (2007). Understanding power and the coach's role in professional English soccer: a preliminary investigation of coach behaviour. *Soccer Society*, 8(1), 33-49.
- Priporas, C.-V., Gatsoris, L., & Zacharis, V. (2005). Competitive intelligence activity: evidence from Greece. *Marketing Intelligence & Planning*, 23(7), 659 - 669.
- Ranson, C., Hurley, R., Rugless, L., Mansingh, A., & Cole, J. (2013). International cricket injury surveillance: a report of five teams competing in the ICC Cricket World Cup 2011. *British Journal of Sports Medicine*.
- SCIP. (2012). Strategic and competitive intelligence professionals.
- Weiss, A. (2002). A brief guide to competitive intelligence: how to gather and use information on competitors. *Business Information Review*, 19(2), 39-47. doi:10.1177/026638202321036222
- Wright, C., Atkins, S., & Jones, B. (2012). An analysis of elite coaches' engagement with performance analysis services (match, notational analysis and technique analysis). *International Journal of Performance Analysis in Sport*, 12, 436-451.
- Wright, S., Bisson, C., & Duffy, A. P. (2012). Applying a behavioural and operational diagnostic typology of competitive intelligence practice: empirical evidence from the SME sector in Turkey. *Journal of strategic management*, 20(1), 19-33.
- Wright, S., & Calof, J. L. (2006). The quest for competitive, business and marketing intelligence: A country comparison of current practices. *European Journal of Marketing*, 40(5/6), 453 - 465.

ARE VOLUNTEER COACHES JEOPARDISING YOUTH SPORT PARTICIPATION?

Liandi van den Berg
North West University, South Africa

ABSTRACT

Quality coaching is critical for ensuring youth sport benefits, however with the number of volunteer untrained coaches engaging in youth sports coaching, it has come to light that children's school sport participation is plagued by major problems. The highly competitive nature of current youth sports has raised concerns about the role of coaches since young athletes experience negative consequences as a result of excessive pressure and anxiety. The aim of this study was to assess the negative consequences of untrained volunteer coaches within the youth sport environment as clarified by the participation experience of mini-rugby participants and their parents. Youth rugby players in the continuum stage 1 (mini-rugby) (n = 192), parents (n = 84) and mini-rugby team coaches (n = 10) completed an adapted version of the Sport Competition Anxiety Test (SCAT) and the Competitive State Anxiety Inventory (CSAI-2) (Martens, Vealey & Burton, 1990) to measure the perception of participants on six factors regarding sport participation. Analysis of variance (ANOVA) indicated statistically significant differences in perceptions regarding aspects of enjoyment, pressure, anxiety, withdrawal and the win aspect ($p < 0.005$) between the mini-rugby players, their parents and the coaches. The higher levels of pressure, anxiety, spectator behaviour influence and the motive to win experienced by mini-rugby as opposed to their parents and coaches' perception indicate the negative impact of untrained coaches in the current school sport environment. The findings highlight risks that need to be addressed and managed during the implementation of organised youth sport programs and calls for the implementation of structured volunteer coach education courses by sport governing bodies.

Keywords: Coaches, youth sports, negative consequences.

INTRODUCTION

For many years the management of organized school sport has been plagued with major problems, one of which is the use of untrained volunteer coaches in youth sports (Hedstrom & Gould, 2004). While quality coaching is essential to foster youth sport participation benefits (Hedstrom & Gould, 2004), the opposite is binding with inadequately trained coaches imparting numerous negative sporting experiences (Fraser-Thomas, Côté, & Deakin, 2008). Coaches play a primary role in teaching children technical, physical, psychological and tactical skills (Norman & French, 2013). This in itself is a diverse and challenging role and coaches need to understand their young athletes well (Leach & Moon, 1999) in order to plan and utilise the training sessions in such a manner as to foster optimal learning and development of skills (Baker, Horton, Robertson-Wilson, & Wall, 2003). For this reason volunteer coaches need training to enhance coaching practices and youth development (Conroy & Coatsworth, 2006). Most volunteer coaches do not receive any formal training in coaching (Conroy & Coatsworth, 2006) and become involved in coaching because of their child's sport participation (Hedstrom & Gould, 2004). Coaches of youth sports therefore have little knowledge regarding child sport development, sport scientific foundations of training or the finer technical details of the sport itself when engaging in coaching practices (Hedstrom & Gould, 2004). Negative consequences for youths derived from untrained coaches' behavior include higher drop-out rates, greater sport specific trait anxiety and higher levels of pressure perceived (Fraser-Thomas et al., 2008; Smith, Smoll, & Barnett, 1995).

Negative behaviour such as abusive language at sport events, disrespect towards other coaches and officials and the exertion of external pressure on the child to perform, has been documented in numerous studies (Kohn, 1992). The frequency of negative sport experiences are in many instances higher than generally perceived (Raubenheimer, & Le Roux, 2008) and according to Lee (1993), coaches and parents mainly are responsible for the destructive sporting occurrences such as a lack of enjoyment and increased withdrawal by the players. Aspects such as pressure and anxiety are primary factors that influence children's sport participation negatively (LeUnes & Nation, 2002) and a win-at-all-costs approach by coaches and parents is identified as the root cause (Cary, Dotinga, & Cornrow, 2004). The aim of this study was to assess the negative consequences of untrained volunteer coaches within the youth sport environment as clarified by the participation experience of mini-rugby players as well as the perceptions of their parents and coaches regarding this aspect.

Youth sport program management

Organizations which implement youth sport programs should clearly define their programs' philosophy, communicate it to the players, coaches and parents as well as train coaches according to achieve the program goals (Fraser-Thomas et al., 2008). The International Rugby Board (IRB) introduced mini-rugby as a means of increasing participation in the sport through the adaptation of the playing field and rules in order to facilitate skill development and enjoyment (Rutherford, 1993). However, within the South African school rugby set-up, unions and schools have the authority to change the original non-competitive and developmental focus of the governing body's initial program intent, to competition formats that are not designed for inherent enjoyment and skill development as it should be during the early sport participation years (Fraser-Thomas et al., 2008). Additionally, the IRB and local South African governing rugby authorities only enforce volunteer coaches to training regarding sport safety aspects (SARU, 2017). Since rugby is a contact type sport, serious injuries are a threat and coaches need appropriate training for safety aspects (SARU, 2017), however, volunteer mini-rugby coaches are left largely to develop their own coaching practices regarding general coaching facets (Côté, Bruner, Erickson, Strachan, & Fraser-Thomas, 2010). The current situation of volunteer and untrained coaches is a cause for concern and the risks of negative consequences on the youth sport participants should be investigated and subsequently minimized through formal and structured coaches training (Conroy & Coatsworth, 2006).

METHOD AND PROCEDURE

A non-probability sampling design in the form of convenience sampling was used to collect data over a two-week period. This method was chosen because it was inexpensive and efficient. In order to overcome the shortcomings of this method, a large sample group was targeted (Sekaran, 2003).

Participants

Six primary schools in the Gauteng province that offered mini-rugby as an organized sport were requested to participate in the study, of which five schools accepted on the condition of remaining anonymous. First and second grade boys, who participated in the current mini-rugby season were recruited to complete a questionnaire voluntarily and anonymously after a parent granted written consent. The boys were between the ages of six to eight years, and the researchers, supported by a research colleague as well as the boys' school teachers, administered the questionnaire in a controlled environment. The boys' parents and the mini-rugby coaches also completed the adapted questionnaire.

Measuring instrument

A two-section questionnaire was used to collect data for the study. Section A requested demographic information, and Section B contained 37 items comprising six subscales, namely enjoyment, pressure, anxiety, spectator behavior, withdrawal and winning motive. This questionnaire was adapted by Raubenheimer and Le Roux (2008),

using the Sport Competition Anxiety Test (SCAT) and the Competitive State Anxiety Inventory (CSAI-2) developed by Martens, Vealy, and Burton (1990). Scales measuring self-confidence (Martin & Hall, 1997) and negative aspects of sport participation such as withdrawal (Cahill & Pearl, 1993) were also included. Items were scored using a four-point Likert-type scale, anchored at one (usually) and four (always). The questionnaire rendered a Cronbach alpha of 0.88 in Raubenheimer and Le Roux's (2008) study. The questionnaire administered by Raubenheimer and Le Roux (2008) was performed on children between the ages of nine to 13 years; hence, an adaptation of the questions was necessary to suit the age-specific language and vocabulary of the six to eight year old mini-rugby players. The questionnaire was additionally adapted to state the same questions to the coaches and parents, but regarding their perception of their boys' rugby participation experience.

Data collection

Limitations in using survey measures with young children are evident since their level of literacy and cognitive capacity is still under developed (Dollman et al., 2009). Expert researchers and school teachers pre-tested the instrument and found the content to be simple, readable, age appropriate and administrable. Additionally his study followed the approach of Roets (2002) whereby individual attention was given in administering surveys to the young children, and correspondingly the reading and language constraints were overcome. Furthermore, the researchers, together with teachers, explained the questions using unadorned language and by referring to examples, thus ensuring that the participants understood each question before they chose their answer.

RESULTS

The data were captured and analyzed using the Statistical Package for the Social Sciences (SPSS – Version 20). Table 1 provides descriptions of the distribution of the three groups and schools. Descriptive statistics indicate that 52.1 percent of the boys were in Grade 1 (played in the under-7 age group) with 47.9 percent in Grade 2 (played in the under-8 age group). This implies that just over half of the respondents had their first exposure to rugby through an organised school sport in the form of mini-rugby.

Table 1: Description of the participants

	Boys		Parents	Coaches
	Grade 1	Grade 2		
Sample size (N)	100	92	84	10
School 1	18	22	18	3
School 2	25	22	10	0
School 3	30	15	21	4
School 4	11	17	9	1
School 5	16	16	26	2

A total of 202 boys completed the questionnaire of which 20 responses were incomplete or inadequate for inclusion in the study rendering 192 responses at a rate of 95 per cent. The 192 boys' parents received the questionnaire adapted to ask the parents' perception about their child's sport experience and eighty-four parents completed and returned the questionnaire, rendering a parent response rate of 44 per cent. From the 19 coaches, 10 responded with questionnaires for a response rate of 52 per cent.

The Cronbach alpha for the scale was 0.846, with individual construct Cronbach alphas for enjoyment at 0.677, pressure 0.666, anxiety 0.805, spectator behavior 0.615, withdrawal 0.614 and winning motive 0.638. Nunnally and Bernstein (1994) suggest that values of 0.70 or above may be considered acceptable, but according to a study by Kim and Kim (1995), a coefficient of 0.5 to 0.6 can be regarded as sufficient, and, therefore, due to the exploratory nature of the study, all constructs (Cronbach alpha >0.6) were deemed satisfactory for discussion purposes. Inter-item correlation values for all six constructs are, according to Clark and Watson (1995), satisfactory as they ranged between 0.15 and 0.50. Inter-item correlation values of 0.246, 0.180, 0.263, 0.248, 0.351 and 0.231

were obtained for the enjoyment, pressure, anxiety, spectator behavior, influence withdrawal and winning motive constructs respectively and indicates a good convergence of validity.

Table 2: Analysis of variance (ANOVA)

Construct		Sum of Squares	df	Mean Square	F-ratio	Sig
Enjoyment ($\alpha = 0.677$)	Between groups	1.296	2	0.648	3.080	0.048
	Within groups	59.547	283	0.210		
	Total	60.843	285			
Pressure ($\alpha = 0.666$)	Between groups	28.965	2	14.483	55.919	0.000*
	Within groups	73.294	283	0.259		
	Total	102.259	285			
Anxiety ($\alpha = 0.805$)	Between groups	16.279	2	8.140	30.408	0.000*
	Within groups	75.754	283	0.268		
	Total	92.033	285			
Spectator behaviour ($\alpha = 0.615$)	Between groups	7.756	2	3.878	8.701	0.000*
	Within groups	126.137	283	0.446		
	Total	133.893	285			
Withdrawal ($\alpha = 0.614$)	Between groups	0.739	2	0.369	1.543	0.215
	Within groups	67.736	283	0.239		
	Total	68.474	285			
Win-motive ($\alpha = 0.638$)	Between groups	46.563	2	23.281	30.377	0.000*
	Within groups	216.895	283	.766		
	Total	263.458	285			

*Significant at $p < 0.05$

ANOVA tests were conducted to assess the statistically significant differences between the boys, coaches and parents. Table 2 reports on these results and indicates that there is a statistically significant difference ($p < 0.05$) in participation experience by the boys and perception of the coaches and parents regarding the pressure, anxiety, spectator behaviour influence and winning motive constructs. Tukey's tests were conducted to determine where the specific differences occurred for these constructs, and as can be seen from Table 3, the boys' group account for the majority of variance. Upon closer examination, it is evident that the boys and parents in particular show the greatest variance, indicating that the parent's perceptions vary greatly from those of the boys' actual experience regarding these four constructs.

Table 3: Tukey HSD

Construct	(I) Group	(J) Group	Mean Difference (I-J)	SE	Sig	95% of confidence interval	
						Lower bound	Upper bound
Enjoyment	Boys	Parents	0.693*	0.666	0.000	0.536	0.850
		Coaches	0.520*	0.165	0.005	0.132	0.909
Pressure	Parents	Boys	-0.693*	0.666	0.000	-0.850	-0.536
		Coaches	-0.172	0.170	0.570	-0.5733	0.229
	Coaches	Boys	-0.520*	0.165	0.005	-0.909	-0.132
		Parents	0.172	0.170	0.570	-0.229	0.573
Anxiety	Boys	Parents	0.506*	0.068	0.000	0.346	0.665
		Coaches	0.527*	0.168	0.005	0.132	0.923
	Parents	Boys	-0.506*	0.068	0.000	-0.665	-0.346
		Coaches	0.022	0.173	0.991	-0.386	0.430
Spectator Behaviour	Coaches	Boys	-0.528*	0.168	0.005	-0.923	-0.132
		Parents	-0.0212	0.173	0.991	-0.430	0.386
	Boys	Parents	0.364*	0.087	0.000	0.158	0.570
		Coaches	0.139	0.217	0.796	-0.371	0.650
Win-motive	Parents	Boys	-0.364*	0.087	0.000	-0.570	-0.158
		Coaches	-0.225	0.223	0.573	-0.751	0.301
	Coaches	Boys	-0.139	0.217	0.796	-0.650	0.371
		Parents	0.225	0.223	0.573	-0.301	0.751
Withdrawal	Boys	Parents	0.8817*	0.1145	0.000	0.612	1.152
		Coaches	0.6115	0.2840	0.081	-0.058	1.280
	Parents	Boys	-0.8817*	0.1145	0.000	-1.152	-0.612
		Coaches	-0.2702	0.2929	0.626	-0.960	0.420
Coaches	Boys	-0.6115	0.2840	0.081	-1.280	.058	
	Parents	0.2702	0.2929	0.626	-0.420	0.960	

*Significant at $p < 0.05$, SE= Standard Error

DISCUSSION

Pressure

Coaches and parents perceive the level of pressure that the mini-rugby players experience much lower than the actual fact. This is similar to the study by Anderson, Funk, Elliott, and Smith (2003) on nine to 11 year old children, which found that children experienced high levels of pressure, which related negatively to the enjoyment of their sport while parents were unaware of this perceived pressure. Coaches and parents pressure young players to perform difficult skills in competitive situations and overlook the fact that the children have inadequate sport specific and pressure handling skills (Fraser-Thomas et al., 2008). Additionally, coaches pressure players to perform during

competitions since their own performance and reinstatement depends on winning matches (Fraser-Thomas et al., 2008; Walters, Schluter, Oldham, Thomson, & Payne, 2012).

Win-motive

According to Cox (2002) an over-emphasis on the winning motive may be seen as the primary reason for a negative sport experience and can lead to elevated pressure. Siegenthaler and Conzalez (1997) advocate that winning is not of paramount importance to children, but that they realise winning is important to adults. Sport competition between schools and in particular mini-rugby, is fierce with coaches eager to show their ability (Walters et al., 2012). This over-emphasis on competition and winning by coaches and parents has been linked to children's feelings of low self-esteem, withdrawal and anxiety (Fraser-Thomas et al., 2008).

Anxiety

Competition anxiety in children is another consequence resulting from the pressure to perform because of a win-at-all-cost motive embraced by coaches and parents (Fraser-Thomas et al., 2008). Coaches are primarily responsible for creating anxiety in children before competitions through their own anxious behaviour and in setting unrealistic expectations for the children (LeUnes & Nation, 2002). When children fail to achieve the expected results, it leads to heightened anxiety as well as low self-competence perception, consequently strengthening the negative experience of sport participation. This may result in the reduction of their initial enjoyment and excitement (Humphrey, 2003), which could result in sport withdrawal.

Spectator behaviour

This study indicated the negative influence parents' side-line behaviour has on children, which correlates with findings by Millar, Oldham, and Donovan (2011). Conduct such as abusive language towards players, disrespect towards coaches and officials, and the adoption of a war-like inclination to the school sport competition set-up, where the opponents are seen as enemies and need to be defeated, fosters a destructive perception of competition by children (Kohn, 1992; Shields & Bredemeier, 2009). This, more often than not, results in unsportsmanlike conduct by players, cheating, feelings of inability, fear of failure, loss of enjoyment, and ultimately withdrawal from competition and participation (Kohn, 1992; Shields & Bredemeier, 2009). Studies reported that adults prejudicially recounted their behaviour in a manner consistent with expected behaviour, but with a 40 per cent discrepancy of actual and recalled actions (Millar et al., 2011). Coaches and parents underestimate the negative influence of their behaviour next to the competition field, while it is evident coaches may perceive parents' behaviour as inappropriate. However, because of inadequate training to handle negative spectator behaviour and situations, coaches do not know how to guide parents to positive side-line conduct (Fraser-Thomas et al., 2008).

CONCLUSION

The current organized mini-rugby sport system utilizes untrained volunteer coaches which evidently are responsible for players' high levels of anxiety and pressure, with lower enjoyment due to inappropriate coaching practices (Fraser-Thomas et al., 2008; Hedstrom & Gould, 2004; Smith et al., 1995). The negative impact of the inadequate coaching practices, inappropriate spectator behavior and an over emphasis on the win-motive by the coaches and parents on the experience of youth mini-rugby participants is a cause for concern for long term sport participation. Sport administrators of the local, provincial and national rugby governing bodies should reduce the associated sport withdrawal risks and the negative influences of untrained, volunteer mini-rugby coaches on the participants. Mandatory and structured coach education programs for volunteer coaches should aim to teach coaches positive coaching behaviors which will address the current negative consequences of inadequate coaching practices (Conroy & Coatsworth, 2006; Fraser-Thomas et al., 2008). Newly implemented coach education courses should focus to

instill the necessary knowledge and skills for coaches to facilitate a positive and developmental sport environment, which will enhance the mini-rugby participation experience of players.

REFERENCES

- Anderson, J. C., Funk, J. B., Elliott, R., & Smith, P. H. (2003). Parental support and pressure and children's extracurricular activities: relationships with amount of involvement and affective experience of participation. *Applied Developmental Psychology, 24*, 241-257.
- Baker, J., Horton, S., Robertson-Wilson, J., & Wall, M. (2003). Nurturing sport expertise: factors influencing development of elite athlete. *Journal of Sports Science and Medicine, 2*, 1-9.
- Cahill, B. R., & Pearl, A. J. (1993). *Intensive participation in children's sports: American Orthopedic Society for Sports Medicine*. Windsor, ON: Human Kinetics.
- Cary, P., Dotinga, R., & Cornrow, A. (2004). Fixing kids' sports. *U.S. News & World Report, 136*(20), 5-7.
- Clark, L. A., & Watson, D. (1995). Constructing validity: basic issues in objective scale development. *Psychological assessment, 7*(3), 309-319.
- Conroy, D. E., & Coatsworth, J. D. (2006). Coach Training as a Strategy for Promoting Youth Social Development. *The Sport Psychologist, 20*, 128-144
- Côté, J., Bruner, M., Erickson, K., Strachan, L., & Fraser-Thomas, J. (2010). *Athlete development and coaching*. Oxford, UK: Elsevier.
- Cox, R. H. (2002). *Sport psychology: concepts and applications*. New York: McGraw Hill.
- Dollman, J., Okely, A. D., Hardy, L., Timperio, A., Salmon, J., & Hills, A. P. (2009). A hitchhikers guide to assessing young peoples' physical activity: deciding what method to use. *Journal of Science and Medicine in Sport, 12*, 518-525.
- Fraser-Thomas, J., Côté, J., & Deakin, J. (2008). Understanding dropout and prolonged engagement in adolescent competitive sport. *Psychology of Sport and Exercise, 9*, 645-662.
- Hedstrom, R., & Gould, D. (2004). *Research in youth sports: Critical issues status. White paper summaries of existing literature*. East Lansing: Michigan State University.
- Humphrey, J. H. (2003). *Child development through sports*. Binghamton: The Haworth Press.
- Kim, D., & Kim, S. Y. (1995). QUESEC: an instrument for assessing the service quality of sport centres in Korea. *Journal of Sport Management, 6*, 208-220.
- Kohn, A. (1992). *No contest. The case against competition*. Boston: Houghton Mifflin.
- Leach, J., & Moon, B. (1999). Recreating pedagogy. In J. Leach & B. Moon (Eds.), *Learners and pedagogy* (pp. 265-276). London: Paul Chapman.
- Lee, M. (1993). *Coaching children in sport: principles and practice*. London: Chapman & Hall.

- LeUnes, A. D., & Nation, J. R. (2002). *Sport psychology*. Pacific Grove: Wadsworth.
- Martens, R., Vealy, R. S., & Burton, D. (1990). *Competitive anxiety in sport*. Champaign, Ill: Human Kinetics Publishers.
- Martin, K. A., & Hall, C. R. (1997). Situational and intrapersonal moderators of sport competition state anxiety. *Journal of Sport Behavior*, 20(4), 435-447.
- Millar, S.-K., Oldham, A. R. H., & Donavan, M. (2011). Coaches' self-awareness of timing, nature and intent of verbal instructions to athletes. *International Journal of Sport Science and Coaching*, 6, 503-513.
- Norman, L., & French, J. (2013). Understanding how high performance women athletes experience the coach-athlete relationship. *International Journal of Coaching Science*, 7(1), 3-24.
- Nunnally, J. C., & Bernstein, I. H. (1994). *Psychometric theory (3rd ed.)*. New York: : McGraw-Hill.
- Raubenheimer, G., & Le Roux, K. (2008). Die jong kind se belewenis van intensiewe sportdeelname. *South African Journal for Research in Sport, Physical Education and Recreation*, 30(1), 75-88.
- Roets, I. (2002). *Die verband tussen moeders se beroepsbetrokkenheid en die psigologiese welstand van hul kinders*. Universiteit van die Vrystaat, Bloemfontein.
- Rutherford, D. (1993). *The complete book of mini rugby*. London: Partridge.
- SARU. (2017). Bok Smart. Retrieved from <http://boksmart.sarugby.co.za/content/what-is-boksmart>
- Sekaran, U. (2003). *Research methods for business (4th ed.)*. Hoboken, NJ:: John Wiley.
- Shields, D. L., & Bredemeier, B. L. (2009). *True competition. A guide to pursuing excellence in sport and society*. Champaign, IL: Human Kinetics.
- Siegenthaler, K. L., & Conzalez, G. L. (1997). Youth sports as serious leisure: a critique. *Journal of Sport and Social Issues*, 21, 298-314.
- Smith, R. E., Smoll, F. L., & Barnett, N. P. (1995). Reduction of Children's Sport Performance Anxiety Through Social Support and Stress-Reduction Training for Coaches *Journal of Applied Developmental Psychology*, 16, 125-142.
- Walters, S. R., Schluter, P. J., Oldham, A. R. H., Thomson, R. W., & Payne, D. (2012). The side line behavior of coaches at children's team sports games. *Psychology of Sport and Exercise*, 13, 208-215.

A HUMAN RIGHTS PERSPECTIVE: FAMILY DISPUTE RESOLUTION IN THE AFRICAN SOCIAL ORDER AND THE RELEVANCE OF CULTURE

**CM van der Bank
Vaal University of Technology, South Africa**

ABSTRACT

The aim of this paper is to explore the influence of cultural rights in family dispute resolution. Scholars and practitioners of human rights will recognize the difficulty in bringing about consensus across academic disciplines and global and local communities on the exact content of human rights (Landman and Carvalho, 2010). The family justice system needs to be developed and orientated to the needs of children and families to foster early resolution of disputes and thereby minimise family conflict. The paper uses the universalism and cultural relativism debate to a discussion of children's right in the African social order in terms of the customary law. Appropriate policies, processes and structures will ensure a coherent family law legislative framework that will assist families to resolve their disputes, both collaboratively (outside the court room) and by adjudication (in the court room). The paper will therefore critically and comparatively consider how African Dispute Resolution attempted to reconcile universal norms with historical and cultural peculiarities in defining right and their resultant effect on children and their welfare.

Keywords: customary law, dispute, family, mediation and reconcile.

INTRODUCTION

The aim of this paper is to explore the influence of cultural rights in family dispute resolution. Scholars and practitioners of human rights will recognize the difficulty in bringing about consensus across academic disciplines and global and local communities on the exact content of human rights (Landman and Carvalho, 2010). The family justice system needs to be developed and orientated to the needs of children and families to foster early resolution of disputes and thereby minimise family conflict. The paper uses the universalism and cultural relativism debate to a discuss children's rights in the African social order in terms of the customary law. Appropriate policies, processes and structures will ensure a coherent family law legislative framework that will assist families to resolve their disputes, both collaboratively (outside the court room) and by adjudication (in the court room). The paper will therefore critically and comparatively consider how African Dispute Resolution attempted to reconcile universal norms with historical and cultural peculiarities in defining rights and their resultant effect on children and their welfare.

THE RELEVANCE OF CULTURE TO CHILDREN'S RIGHTS

“Culture” has been defined as “the whole complex of distinctive spiritual, material, intellectual and emotional features that characterise a society or social group. It includes not only acts and letters but also the fundamental rights of the human being, value systems, traditions and belief” (World Conference on Cultural Policies, 1982). Several international human rights instruments have given expression to the recognition and protection of cultural rights. Notable among these is the Universal Declaration of Human Rights, which stipulates that persons belonging to the ethnic, religious or linguistic minorities: “Shall not be denied the right in community with other members of their group, to enjoy their own culture, to profess and practice their religion, or to use their own language” (Article 27(1) of the Universal Declaration of Human Rights). E Jebb (founder of Save the Children International Union 1928) noted that it was important to develop children’s rights in harmony with local traditions, needs and opportunities so that what is good is accepted and what is bad is rejected (E Jebb, 1928).

African Dispute resolution is relevant to the discussion on the resolution of all family disputes. However, issues relating to customary law and culture should also be taken into account when discussing African Dispute Resolution. A large number of African children are regulated by customary law rather than by common or statutory law. Therefore, to advance children’s rights, there is a need for us to critically engage with some of the issues and questions that arise in our attempt to reconcile universal standards with differing socio-cultural values. The aim of this paper is to explore the influence of culture on the rights of the child from a South African human rights perspective.

CUSTOMARY LAW

On the face of it there should be no difference between custody and care of children of different racial groups in South Africa. However, in practice it is not possible to apply universal norms. The African social order in which African children are born and live calls for a different approach.

In customary law, the terms “custody and care” and “access and contract” are hardly ever used. The emphasis is on deciding which family a child is affiliated with (Bekker, 2008). It is essential to explore the manner in which international and South African law defines “the family” and how the definition of impact on the various aspects of children’s lives and rights. The traditional definition of family which revolves around the marital union and blood relationships between husband and wife, parent and child has been expanded to recognise other unconventional family ties. In *Madyibi v Nguva* (1944 NAC (C & O) 36) the rules of affiliation are stated. In an African context, it is better to say that children belong to their father’s family. By nature a child would accrue to his or her maternal grandfather’s group and be a member of his group only on contraction of a valid customary marriage whereby the women’s group receives “lobolo” from the group and transfers natural rights to the women’s reproductive power, and her existing children to the group that gave lobolo. Biological parents do not have necessarily custody or care of their children. However, affiliation always affords the children security. Even if the biological parents pass away the child would be an orphan in the western sense of the world (Bekker and Boonzaaier, 2007). The importance of cultural values cannot be ignored in any definition or discussion of the family. Unlike the dominant conception of family in the west, African society is communitarian and resolves around the extended family.

Nhlapo describes Swazi parenthood as follows: “All those relationships are characterised by the movement of children within or without a kinship to be placed temporarily or permanently, with someone other than the biological parent. Sometimes such movement entails a physical change of residence; often it is notional as in the case of a child’s ritual attachment to a godparent or allocation to a different branch of the family. These movements are widespread and institutionalised in many societies and the parent-child relationship they create can aptly be described as social parenthood” (Nhlapo; 1993). Social parentage is widespread. The children retain their original legal status, family name and rights and duties acquired by birth in the name of the father’s home,

but in fact they are under the custody and control of the foster parents. Children are sometimes for practical reasons, placed with someone other than the biological parent for example where parents live and work away from home, someone back home undertakes the role of the foster parent. Quite sadly peers are often entrusted with the responsibility.

Bekker describes that children of an unmarried women belong to the mother's male guardian, namely her maternal grandfather or his successor (Bekker, 2008). In addition to the supportive influence of the extended family, recognition of other forms of family life is imperative in constitutional democracy that affords legal protection to family members without discrimination. The principle that unmarried women and their children under perpetual guardianship did not change with the implementation of the Customary Marriages Act 120 of 1998.

Fathers may be the heads of family and mothers are mostly the *de facto* custodians. In terms of customary law the father's right to the care and guardianship of his children was absolute. The court as the upper guardian of all minors, has, however, modified customary law in this respect by emphasising that the best interest of the children are decisive (*Hlophe v Mahlalela* 1998 (1) SA 449 (T)).

In a multicultural society as South Africa, the differences that exist between various cultural traditions that guide societal and parental attitudes in the area of parent-child relationships and childrearing methods raise constitutional questions that are not only directly touch on the rights of children but lie at the core of certain constitutional guarantees as they relate to the parents or families.

THE RIGHT TO CULTURE AND THE BEST INTEREST OF THE CHILD

This question is closely allied to the aforementioned social considerations, because Africans had, and some still have, firm views and practices about the passage from childhood to adulthood. Chronological age was not a consideration.

In the Act a child is defined as a person under the age of 18 years (Children's Act s1(1)(g)). This is obviously meant to bring the age in line with section 28(3) of the Constitution in terms of which a child means a person under the age of 18 years (Constitution, 1996). That, then is the age that has been chosen for the operation of the Act. It must be mentioned though that Africans never viewed childhood in terms of chronological age. On initiation, which went hand in hand with circumcision, a Xhosa boy acquired the status of a man. Puberty again followed by a ceremony, called *intonjane* by the Xhosa, raised the status of a girl to that of an adult (Van Tromp, 1947).

On the other hand, Zulu boys do not go through any specific ceremony to mark the transition from boyhood to manhood. They do not undergo circumcision. According to De la Harpe, Leitch and Derwent: "It is rather a gradual evolutionary process, marked by subtle changes indicating that they are growing up" (De la Harpe, et al 1998).

Other communities also practices circumcision, almost with religious zeal, and some have coming of age ceremonies for girls. However, the practices are too varied and vague to serve as a general criteria for determining adulthood, or in common law parlance, majority status. The definition of a child as a person under the age of 18 years was obviously called for to create uniformity.

The age of majority of any person in terms of the Age of Majority Act was 21. In terms of section 17 of the Act – "A child, whether male or female, becomes a major upon reaching the age of 18 years".

Be that as it may, the African view of childhood and adulthood will not change as of now. Initiation ceremonies will be performed as heretofore. If, of course, there is a legal conflict the statutory age of majority will prevail, such as for determining contractual capacity and the right to marry without parental consent.

This Bill of Rights is a cornerstone of democracy in South Africa. It enshrines the rights of all people in our country and affirms the democratic values of human dignity, equality and freedom. The state must respect, protect, promote and fulfil the rights in the Bill of Rights. The inclusion of the right to culture (Bill of Rights, section 30 and 31) and the equality clause (section 9) has serious implications for the rights of women and children who are often disadvantaged by the application of customary law, especially in the area of family law.

The South African Constitution recognises the right of persons to participate in the cultural life of their choice in so far as it is not inconsistent with any provisions of the Bill of Rights. Courts continue to grapple with how to balance competing rights when the right to culture is pitted against some other fundamental right such as the right to equality. All rights are interdependent, interrelated and indivisible. Justice Sachs supports the view by Professor Bennett that states our Bill of Rights is not based on a hierarchy of rights, nor is it an assemblage of categorically defined rights sealed off from each other. It rather contemplates the interdependence of mutually supportive rights (Sachs, 1999). The universal principle of the best interest of the child can be creatively used to facilitate the reconciliation between culture and children's rights.

Cultural rights are only applicable in so far as their exercise is consistent with the Constitution (Internal limitations of section 15, 30, 31 and 211). No constitutional challenges involving cultural rights per se have come before the South African courts (Mubangizi, 2004). However, on occasion the courts have been afforded the opportunity to engage with reconciling this seemingly outmoded and oppressive legal system with the new constitutional values. No area of customary law has been subjected to as much constitutional challenge as customary family law.

The best interest of the child is the foundational principle in children's right law in international, regional and domestic law. Judge Ngobo in *Bhe and Others v Magistrate, Khayelitsha and Others*, (2000) recognises that it is always in the best interest of the child for the family unit to be protected and kept intact. He also articulates that court should not negate their duty in assessing the best interests of the child as the paramount consideration. Bekker also states that the court order or mediation report will be guided by the best interest of the child (Bekker, 2008). In determining the best interest of the child the court or mediator should take African cultural values and belief systems into account, for example the child's link with their ancestors (Rautenbach and Bekker, 2014).

ALTERNATIVE DISPUTE RESOLUTION VERSUS AFRICAN DISPUTE RESOLUTION

ADR is the general accepted acronym for alternative dispute resolution. ADR provides an opportunity to resolve disputes through the use of a process best suited to particular disputes and conflicts. Alternative Dispute Resolution is a term used to describe several different methods of resolving legal disputes without going to court. The rising cost of litigation is making traditional lawsuits impractical for many individuals and businesses.

Therefore ADR may be described as a pluralistic system of dispute resolution, in which one of several processes may be selected as an expedient mechanism for resolving a particular type of dispute (Faris, 2013).

Western mediation is a process with ancient roots – a process that has been re-engineered to suit the needs of highly industrialised urban societies and has discarded the social context that originally underscored it. According to Faris, Western mediation serves the needs of “self-existent, individual and autonomous societies” that are “equipped with the service of a complex commercial sector and court system” (Faris, 2011). With court-annexed mediation (which seems to be rising in popularity and success), community mediators find their work institutionalised within the very processes for which those mediators are supposed to offer an alternative.

Mediation as it is currently practiced in South Africa is a service profession, but has also established as an academic discipline (Faris, 2011). Mediators need to be accredited by a professional body, and mediation generally occurs in a formal setting. Usually the person who is the mediator has no prior relationship with the disputants. There is generally a mediation agreement that states the “ground rules” for the mediation process, and sets out the roles and responsibilities of the parties to the mediation. There are recognisable stages that

occur during the mediation process. The objective of Western mediation is that consensus is reached and that this gives rise to a settlement agreement (Faris, 2011).

The mediator's ultimate role is to do anything and everything necessary to assist parties to reach agreement. In serving this ultimate end, the mediator may take on any or all of the following roles:

- Convener: “The mediator may assist in contacting the other party(ies) to arrange for an introductory meeting” (Moore, 1996).
- Educator: The mediator educates the parties about the mediation process, other conflict resolution alternatives, issues that are typically addressed, options and principles that may be considered, research, court standards, etc.

Factors that could strongly influence the accessibility of mediation are whether the necessary infrastructure exist, the availability of mediators, language and cultural barriers, and the cost of mediators.

In African mediation, conflicts are seen in their social context. In Africa there is the tradition of family or neighbourhood mediation. They are not seen as isolated events; all relevant background information is covered during mediation. This mediation is facilitated by elders and takes place in an attitude of togetherness and in the spirit of *Ubuntu*. During mediation, not only the consequences for the parties are looked at but also the consequences for other people in the respective families. Family ties and community networks are respected, maintained, and strengthened. The traditional objectives of African mediation are to soothe hurt feelings and to reach a compromise that can improve future relationships. African group mediation shows a commitment to the community and a comprehensive view of life. Therefore mediation is compulsory in African culture. The values that are upheld in African mediation are African humanistic values.

In African mediation, conflicts are seen in their social contexts. They are not seen as isolated events and all relevant background information is covered during mediation. The traditional objectives of African mediation are to soothe hurt feelings and to reach a compromise that can improve future relationships.

The *Lekgotla/Inkundla* is a group or public mediation forum. The entire community is involved, the disputants and their family members, witnesses as well as members of the public. The mediation is conducted by the elders and the headman or chief. They provide the forum and listen. All present have the right to ask questions and to make suggestions for the resolution of the dispute. The elders guide the process and also have investigative functions. They intermedicate between the chief or headmen and the community and advise the headman or chief. The objective of the mediation is to restore social equilibrium. The elders do not have formal mediation qualifications. Mediatory authority is conferred on elders because they have a reputation in the community as persons with wisdom and integrity and because they understand the cultures and traditions of their people. The basis of settling disputes is reconciliation instead of retribution or punishment and is more important than stating the rule of law. Mediators are entitled to change their roles from time to time according to the needs they sense at various times. Because marriage is between families, families deal with marriage disputes, violations and abuse in a way that is reconciliatory and not adversarial.

The African model can only be fully understood within the context of Ubuntu or Botho, or any of the other names for this concept in various African languages (Faris, 2013). Ubuntu is generally understood as the African rationale for humaneness, and is central to the African ethical system. Personhood is expressed in the solidarity of reciprocal relationships with others, such as “a person is a person through other people”. The ultimate objective of mediation then is to restore social equilibrium.

In brief, the Western approach assumes a confrontational model of dispute resolution, whereas the African harmony model presupposes social harmony, which needs to be restored when disrupted by conflict.

The Children’s Act, 2005 was influenced by the principles of African group mediation. The Act provides for mediation as a method of dispute resolution involving parental responsibilities and rights. The Act

contains some similar elements to the African dispute resolution. It is clear from that South African children's rights discourse has not only influenced the recognition and protection of family life but it has also fundamentally altered the internal workings of the family unit (Moyo, 2014). Like every other society, the family is the basic unit of South African society. The South African Constitutional Court has recognised that families come in many shapes and sizes and that the definition of family though useful, changes as social practices and traditions change (*Dadoo and Another v Minister of Home Affairs* 2000). The protection and recognition of the family entails not only its protection as a unit against unwarranted state intervention and respect for its privacy but also the regulation if not monitoring the rights of the child within this private unit. The Children's Act provides for mediation as a method of dispute resolution, particular with regard to disputes involving parental responsibilities and rights. The issue of parental rights of their children has received a considerable amount of attention since the establishment of the state.

The Children's Act specifies that in any matter that concerns a child, an approach that is conducive to problem-solving and conciliation should be followed, and a confrontational approach should be avoided (Section 6(4) of the Children's Act 38 of 2005). Religious and philosophical convictions of parents underpin various decisions that they make with regard to their children. Like culture beliefs they define societal understandings of the parent-child relationship and in turn at the larger level the relationship between the family and mediation.

Africans have an ingrained belief that children "belong" rather than being under the guardianship or in the custody of either parent, especially of the mother (Bekker, 2008). In *Madyibi v Nguva* (NAC 40) the rules of affiliation were stated: 'By nature the progeny of a woman accrue to her father's group and are members of his group and tribe... These rights and duties are transferred by Native law to another group only on contraction of a valid customary union whereby the woman's group receives *lobolo* from the other group and transfers the natural right to the woman's productive power and her progeny to the group providing *lobolo*. Although this means that the biological parents do not necessarily have custody of their children, affiliation always affords care and security and also in the case of mediation.

De la Harpe states that in so far as standards have to be complied with an interesting possibility exist in Australia namely accreditation as an experienced qualified mediation practitioner. They are candidates who have been assessed by an accreditation body as demonstrating a level of competence by reference to the competencies expressed in practice standards. An experienced qualified mediator must be resident in a linguistically and culturally diverse community for which specialised skills and knowledge are needed and/or from a rural or remote community where there is difficulty in attending a mediation course or attaining tertiary or similar qualification (De la Harpe, 2014).

Section 21, 33(2) and 5 of the Children's Act provides for compulsory mediation. If the mediation succeeds, the parties may have the parenting plan registered with the Family Advocate or made an order of court. The Children's Act implies that mediation should take place (section 22(1)). If a matter brought to the children's court is contested, the court may order that a pre-hearing conference be held with the parties in order to mediate between the parties, to settle the disputes between the parties, and to define the issues to be heard by the court.

Globalisation should entail the recognition and integration of the plurality of knowledge systems. Globalisation on the whole impacts negatively on the development and consolidation of democratic governance (Addis Ababa, 2002). One major positive impact of globalisation on Africa is that it has made available information on how other countries are governed and the freedoms and rights their people enjoy. Globalisation could perhaps be the single most significant phenomenon that has ever taken place in the 21st century (Mamba, Jordaan and Clance, 2015).

THE ROLE OF TRADITIONAL LEADERS

The Children's Act section 71(1) envisages a role for traditional authorities in the care of children. "The children's court may, where circumstances permit, refer a matter brought or referred to a children's court to any appropriate lay-forum, including a traditional authority, in an attempt to settle the matter by-way of mediation out of court". The traditional authorities are organ of the State as defined in section 239 of the Constitution (The

Constitution, 1996). Traditional leaders play a significant role in an attempt to settle any matter by way of mediation. Traditional leaders are the eyes and ears of welfare agencies in identifying child-headed households.

CONCLUSION

Both the ADR and the AfDR have strengths and weaknesses. States shall respect the rights that apply to each child within the jurisdiction of State Parties without discrimination of any kind such as, the culture to which the child or his parents adhere. The exchange and integration of knowledge in order to develop a globally relevant system of dispute resolution. Best practice intervention tools will not take root in local contexts unless they are created from within those social contexts, or are modified or even partially dismantled by those who use them.

In divorce and family dispute various proposals have been developed to incorporate the AfDR. Indigenous knowledge systems can be creatively and innovatively applied to conflicts and challenges, as well as in an attempt to devise African solutions for African problems especially at community level. The following proposals have been made to approve the Western mediation disputes in family and divorce disputes by incorporating AfDR:

- All members of the community should be entitled to participate in the mediation circles, and this should not be closed to other family members. The concept of African group mediation will then be examined and attention will be paid to the Ubuntu-influenced values found in African group mediation, as well as the general principles of African dispute resolution and the mediator's role in African-style group mediation (Boniface A.E., 2012).
- The process should not be non-adversarial, with the emphasis being on value-based, restorative outcome which benefits the whole community. "These benefits are found in a combination of transformative and family inclusive mediation, but African conflict resolution goes beyond these models of mediation, as it includes *Ubuntu*-style values. All members of the community are entitled to participate in African dispute resolution, whereas in Western-style mediation circles this is not always so and many circles are "closed" (Boniface, A.E., 2012).
- The extended family should be included in the mediation process. Two elders from either side of the family could fulfil the role of investigators and go-betweens, if this accords with the beliefs of the parties in mediation.
- Mediation should be multi-generational where possible; story-telling must take place. Mediation must allow for the venting of anger and the release of emotion therefore emotional and spiritual spheres may be integral to the mediation. Parties must be seen as consisting of body, mind and soul. In Western mediation practice, conflict and violence are typically seen as destructive and unhelpful ways of being, and this attitude precludes the constitutive and productive role that conflict plays in many non-Western traditions. The playing out of these assumptions in mediation practice effects an operation of power that is particularly significant in intercultural co-mediators and mediations. It arises among people of both similar and different cultural backgrounds when mediations are provided solely through the dominant Western culture". (Bigg, M; 2003).
- Social contexts must be part of a broader mediation process, which may include visits to individuals' or families' homes. Mediators may become more personally involved with the parties than would normally be accepted in Western-style mediation. Within a holistic system, disputes are not seen as separate from the socio-economic conditions of the disputants and their extended communities. Elements of African group-style mediation are currently being applied in restorative justice in South Africa, particularly in the form of family group conferencing for juvenile offenders. Restorative Justice is an approach to justice that aims to involve the parties to a dispute and others affected by the harm (victims, offenders, families concerned and

community members) in collectively identifying harms, needs and obligations through accepting responsibilities, making restitution, and taking measures to prevent a recurrence of the incident and promoting reconciliation. Restorative Justice sees crime as an act against the victim and shifts the focus to repairing the harm that has been committed against the victim and community. It believes that the offender also needs assistance and seeks to identify what needs to change to prevent future re-offending (Department: Justice and Constitutional Development, www.justice.gov.za/rj/rj.html). This principle of African group-style mediation could also be used within the spheres of mediation for by the Children's Act. This can be done by incorporating elements of African group mediation in mediation sessions mandate by the Children's Act. These elements should also be successfully included in private divorce and family mediations that take place in South Africa, as well as in court-mandated mediation.

- Mediation must also allow for the participation of children, in order to comply with international and South African legislation.
- A client-centred approach requires the deepest respect for the client's culture and language.

Appropriate policies, processes and structures would ensure a well-structured and cohesive family law framework that can assist families to resolve their disputes. Parties should have the freedom to tailor the procedure they follow to meet the needs of their particular dispute.

REFERENCES

Age of Majority Act 57 of 1972.

Article 27(1) of the Universal Declaration of Human Rights.

Jebb, E. cited in D Marshall. (2004). 'Children's rights in imperial political cultures; Missionary and humanitarian contributions to the conference on the African child of 1931' 12. *The International Journal of Children's Rights*, 273-290.

Bekker, J.C. (2008). "Commentary on the impact of the Children's Act on Selected Aspects of the Custody and Care of African Children in South Africa", *Obiter* 395.

Bekker, J., & Boozaier, C. (2007). De Jure 'How equal is equal? Legal-anthropological note on the status of African women in South Africa', 277-289.

Bhe and Others v Magistrate, Khayelitsha and Other., 2000(3) SA 867 (SCA) [2000] 3 All SA 219

Bigg, M. (2003) 'Mediation, Power and Cultural Difference' *Conflict Resolution Quarterly* Vol 20 no. 3 Spring Wiley Periodicals pp 287-306.

"Biological and Social Parenthood in African Perspective; the movement of Children in Swazi Family Law" in Eekelaar and Sarcevic (eds) *Parenthood in Modern Society; Legal and Social Issues for the Twenty-first Century* Boniface, A.E. "African-Style Mediation and Western-Style Divorce and Family Mediation; Reflections for the South African Context' (2012) 15 Potchefstroom Electronic Law Journal Vol 15 No 5, 378.

Children's Act 35 of 2005.

Customary Marriages Act 120 of 1998.

Dadoo and Another v Minister of Home Affairs; Shalabi and Another v Minister of Home Affairs and Others; Thomas and Another v Minister of Home Affairs and Others 2000 (3) SA 936 (CC) 2000 (8) BCLR 837.

De la Harpe, S., (31 July 2014). ‘Mediation in Family Law; Access to Justice or Inferior Justice?’ Paper presented at the SAAM Conference Johannesburg on De la Harpe, Letch, S., & Derwent, (1998) *Zulu* Struik publishers.

126 participants in Addis Abada “The challenges of Globalisation in Africa What role for Civil society and Department: Justice and Constitutional Development; Restorative Justice; the road to healing www.justice.gov.za/rj/rj.html.

Faris, J.A. “Alternative Dispute Resolution and African Dispute Resolution; Critical comparisons’ Paper presented at the Cardozo School of Law, New York on 27 February 2013.

Faris, J.A. (28-30 April 2011). “From Alternative Dispute Resolution to African Dispute Resolution; Towards a New Vision” Paper presented at the 5th Caribbean Conference on Dispute Resolution Jamaica.

Hlophe v Mahlalela. (1998). (1) SA 449 (T).

Rautenbach, C., & Bekker, J.C. Introduction to Legal Pluralism in South Africa 4ed Lexis Nexis 2014 at 112).

Landman, T., & Carvalho, E. (2010). *Measuring Human Rights*. Routledge.

Other stakeholders, Ethiopia, (2002).

Mamba, B., Jordaan, A.C., & Clance, M. (2015). ” Globalisation and Conflicts: A Theoretical Approach” University of Pretoria, Department of Economics, 1-26.

Mexico City Declaration on Cultural Policies was adopted by UNESCO in 1982.

Madyibi v Nguva. (1944). (NAC (C & 0) 36).

Madyibi v Nguva. (1944). (NAC 40).

Moore, C. (1996). *The Mediation Process: Practical Strategies for Resolving Conflict* Jossey-Bass San Francisco.

Moyo, P.T. (2014). The relevance of culture and religion to the understanding of children’s rights in South Africa. LLM Dissertation University of Cape Town.

Mubangizi, J.C. (2004). *The protection of Human Rights in South Africa*, Juta.

Rautenbach, C., & Bekker, J.C. (2010). *Introduction to Legal Pluralism in South Africa* 3 ed Lexis Nexis.

Sachs, A. ‘Towards the Liberation and Revitalization of Customary Law’ Pre-Dinner address at the Southern African Society of Legal historians Conference on ‘law in Africa: New Perspectives on origins, foundations and transition’ Held at Roodevallei Country; Lodge, Pretoria on 13 January 1999.

The Constitution of the Republic of South Africa 108 of 1996.

Van Tromp *Xhosa Law of Persons: A Treatise on the Legal Principles of Family Law relations among the Ama Xhosa* (1947).

UNSUCCESSFUL SME BUSINESS TRANSFERS

**Elina Varamäki, Juha Tall, Anmari Viljamaa,
Anne-Maria Mäkelä & Marko Matalamäki
Seinäjoki University of Applied Sciences, Finland**

ABSTRACT

Business transfers are becoming gradually more common among small businesses, largely due to aging of entrepreneurs. In our paper a business transfer is defined as a change of controlling ownership of any firm or business to another person or firm outside the family. In order to promote and support quantitative and qualitative success of business transfers, it is important to understand why some business transfers fail during the negotiation phase. Therefore, the purpose of this paper is to explore, from the buyers' and sellers' perspective, the reasons business transfers fail at the negotiation phase.

Keywords: business transfer, acquisition, small and medium sized enterprises, buyer, seller.

OBJECTIVES OF THE PAPER

Business transfers are becoming gradually more common among small businesses, largely due to aging of entrepreneurs. Existing business transfer research, however, tends to focus on mergers and acquisitions of publicly traded large firms. In our paper a business transfer is defined as a change of controlling ownership of any firm or business to another person or firm outside the family. Earlier research has presented evidence both on successes (for example Tall 2014, Varamäki, Heikkilä, Tall, Viljamaa, and Länsiluoto 2013; Teerikangas 2012; Seth, Song, and Pettit 2002; Aiello, and Watkins 2000) and failures (for example Baker, Butta, Saadi, and Zhu 2012; Chatterjee 2009; KPMG 2006; Langford, and Brown 2004; Dyer, Kale, and Singh 2004; Seth, Song, and Pettit 2002; Marks, and Mirvis 2001) of business transfers. Failure in a business transfer can mean either failure before or after the actual business transfer. In the first case the potential transfer does not take place despite negotiations. In the latter case the intended results are not achieved although the transfer is accomplished. Previous research has largely focused on how the integration succeeds, how the new owner is able to achieve his objectives, and how well the integrated firm performs under the new ownership (see for example Marks, and Mirvis 2011; Very, and Schweiger 2001). Business transfer negotiations that fail without achieving a transfer have received little attention among researchers.

In order to promote and support quantitative and qualitative success of business transfers, it is important to understand why some business transfers fail during the negotiation phase. Therefore, the purpose of this paper is to explore, from the buyers' and sellers' perspective, the reasons business transfers fail at the negotiation phase. The objectives are to analyze a) the problems and key reasons for unfinished negotiations in small business transfers, b) learning from and satisfaction with the negotiation process and c) whether the previous experience in selling and acquiring a firm has any connection with the level of progress achieved in business transfer negotiations.

LITERATURE REVIEW

Challenges and success factors of business transfers can be divided in accordance with the process (Graebner, Eisenhardt, and Roundy 2010, 78-81; Very, and Schweiger 2001, 19). This paper focuses on pre business transfer phase and more precisely on business transfer negotiation phase. Negotiation phase starts with the first contact between potential seller and potential buyer and ends with the making of an actual agreement on the business transfer (Tall 2014, 156). Pre business transfer phase critical success factors include 1) choice and evaluation of the strategic partner among limited number of potential candidates and identification of potential business transfer advisors, 2) the right price, 3) overall strategy and accumulated experience on business transfers, 4) courtship (Gomes, Angwin, Weber, and Tarba 2013, 17; Very, and Schweiger 2001, 19). Establishing trust and confidence through 'courtship' can allow realistic action planning, effective communication and appropriate negotiation and bargaining styles (Gomes et al. 2013; Sebenius 2002; 1998). Lack of trust makes it difficult to evaluate target business resources, competences and the buyer's intentions (Gomes et al. 2013, 21). For the buyer reliable information about the target business is essential (Very, and Schweiger 2001, 18). According to earlier research, successful buyers build an experienced deal team that gets involved in the business transfer (Rovit, Harding, and Lemire 2004, 20; see also Varamäki et al. 2013).

METHODOLOGY

In this study we use mixed-methods approach to integrate both quantitative and qualitative methods to provide a larger understanding for this complex phenomenon than either methodology would provide alone (Hurmerinta-Peltomäki and Nummela 2006). Mixed-methods approach allows theory generation and testing, and offers an opportunity for data triangulation (Molina-Azorin et al. 2012). The mixed-method approach has a long tradition in the social sciences (Erzberger and Prein 1997), and particularly it has been suggested to benefit entrepreneurship research (Davidsson 2003; Westhead and Wright 2000). By adopting a mixed-method approach, this study benefits from and contributes to the interaction of qualitative and quantitative data provided us with an opportunity for presenting a greater diversity of views and findings. The quantitative data was collected during the summer 2014 using an internet survey aimed at sellers and buyers who had experienced a failure in business transfer negotiations in Finland during the years 2011–2014. A total of 156 replies were received, 40 from buyers and 116 from sellers. The data was analyzed with SPSS using distributions, averages and T-tests. In addition to the questionnaire survey, 20 cases were interviewed by telephone or face-to-face, whether they were either a seller or a buyer in an unsuccessful business transfer process. Of the 20 cases, 7 were buyers and 13 sellers. The interviewees were found through the networks of the research team's members and the areal entrepreneur organization experts. Interviews were being conducted by five different interviewers

In the both samples, studied companies were SMEs. In survey data the average size of the target firm, in both selling and acquiring, was from two to four employees and a turnover between 100 000 € and 499 000 €. This fits earlier results in Finland (Varamäki et al. 2013) suggesting that similarity in size between sellers and buyers is common. Most of the target firms were in the service sector (40 percent for selling, 35 percent for acquiring) and located in the same area as the buyer (over 50 percent). The level of previous experience, measured with a 1 to 5 Likert scale (1=no experience at all to 5= considerable experience) in acquiring a firm was 3.3 (buyers) and 2.1 (sellers), and in selling a firm 2.2 (buyers) and 2.4 (sellers), i.e. buyers had more experience in acquiring ($p < .001$) and sellers slightly more experience in selling.

RESULTS

In the case study part, interviewees were asked to state in their own words and freely the story of a failed business transaction process. The interviewees made the necessary supplementary questions regarding the story. For each

interview, the interviewers made notes, and the interviews were also recorded and transcribed. The interviews were also written as intensive case stories, and the summary and main findings are presented in the next paragraph.

There was more than one reason for the fail of the business transfer in 12 out of 20 cases. The most common reasons for the interruption were the strategic disagreement between the purchaser and the buyer (11), as well as the different opinion of the valuation (10). Financing arrangement was the thirdly most common reason for the interruption in negotiations (7). However, this came out only with the sellers' interviews. Distinctions between the valuation may have many different dimensions. They may exist, for example, between buyer and seller, between different experts, and between the financier and the trading partners. There may also be a number of reasons why a buyer cannot get funding. This may be a lack of collateral, lack of trust of financiers in the business being traded, the business sector or the ability of the buyer to take business forward. Lack of trust may be due to a particular event during negotiations (e.g. delay in delivering financial information for a buyer) or there may be more reasons for them to have a lack of confidence. The late launch of the business transfer emerged as a reason for the interruption in only two cases, but this is likely to result in a drop in the number of available alternatives, or even a drift may result in the only option being a termination of the business. This lack of expertise can be divided into two subgroups based on this research material. It may be that there are not enough external experts in the negotiations or that the quality of the experts used does not meet the need. In the fifth of cases (4), one of the reasons for the interruption was the seller's emotions to the subject of the deal. An interesting detail is that the emotional bond was by no means the only reason for the interruption of the negotiations. Strategic incompatibility is common but also somewhat ambiguous. The background may be mainly the purchasing target, the buyer proposition, or both.

In the survey study, negotiations lasted between one to six months on average, and progressed until middle phase or a bit further. The items on which the parties had agreed upon prior to ending the negotiations included the object of the transfer (87 percent), the role of the seller after the transfer (55 percent), timing of the transfer (39 percent), price (35 percent) and other terms of the business transfer (26 percent). Previous experience in selling a firm had a positive effect on the number of items the parties were able to agree upon ($p=0,002$). However, experience in acquiring didn't have similar effect.

The failure of negotiations was generally the result of several problems rather than a single issue. From the buyer's perspective, the seller's high asking price was the main problem (average 4,0 on a scale of 1-5, 1= not a problem and 5=an extremely big problem) followed by valuation (mean 3,2) and funding (mean 2,7). Preparing the contract and learning about the target have no serious trouble. For sellers, the key problems were funding (mean 3,3), finding the buyer (mean 3,2), valuation (3,0) and buyer's too low a price offer (2,9). Funding was a major problem in retail trade (mean 3,8) and manufacturing (mean 3,7) but less so in the service sector (mean 2,9; $p=.012$). Valuation was a more of a challenge among micro firms than slightly larger firms (mean 2,9 for firms with 2-9 employees and 2,7 for firms with ten or more employees; $p=.023$). Of the buyers, 68 percent rate the sellers' high asking price, and 45 percent the target not meeting their expectations as the most or the second-most important reason for the failure to complete the deal. Of the sellers, however, 63 percent find that the most or the second-most important reason for failure is that the buyer did not really want to buy and 47 percent that the buyer was unable to secure financing. The differences between buyers' and sellers' perceptions are statistically very significant ($p=.000$).

Figure 1: Main reasons for the fall of business transfer – Buyer’s perspective

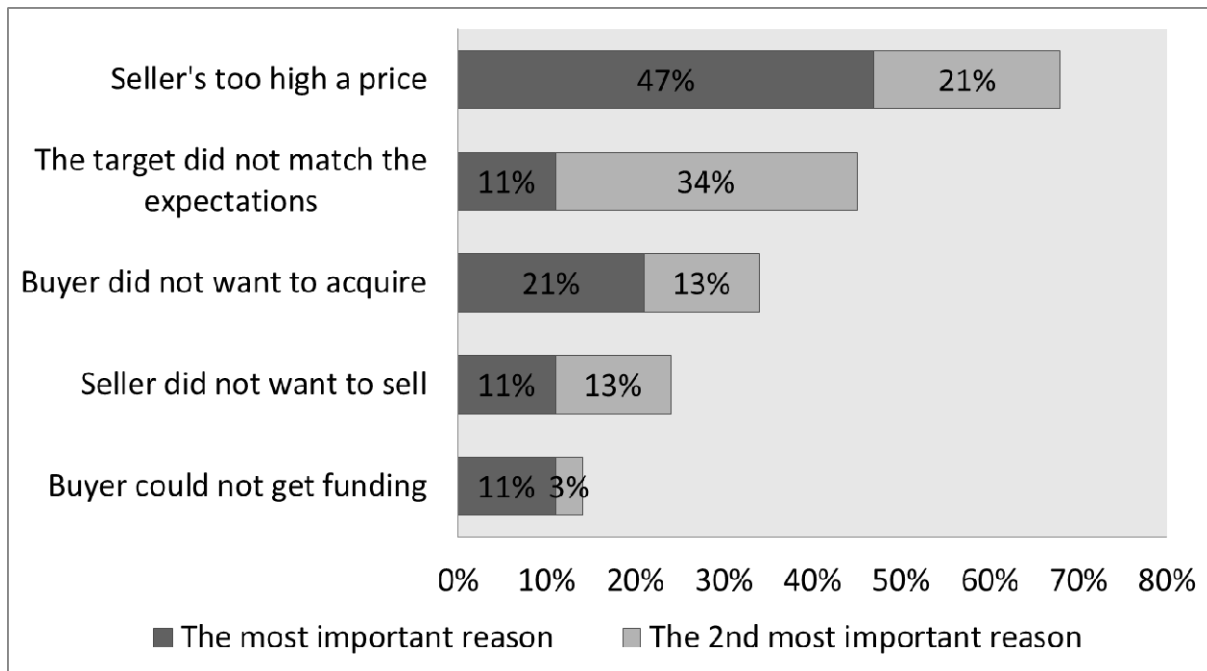
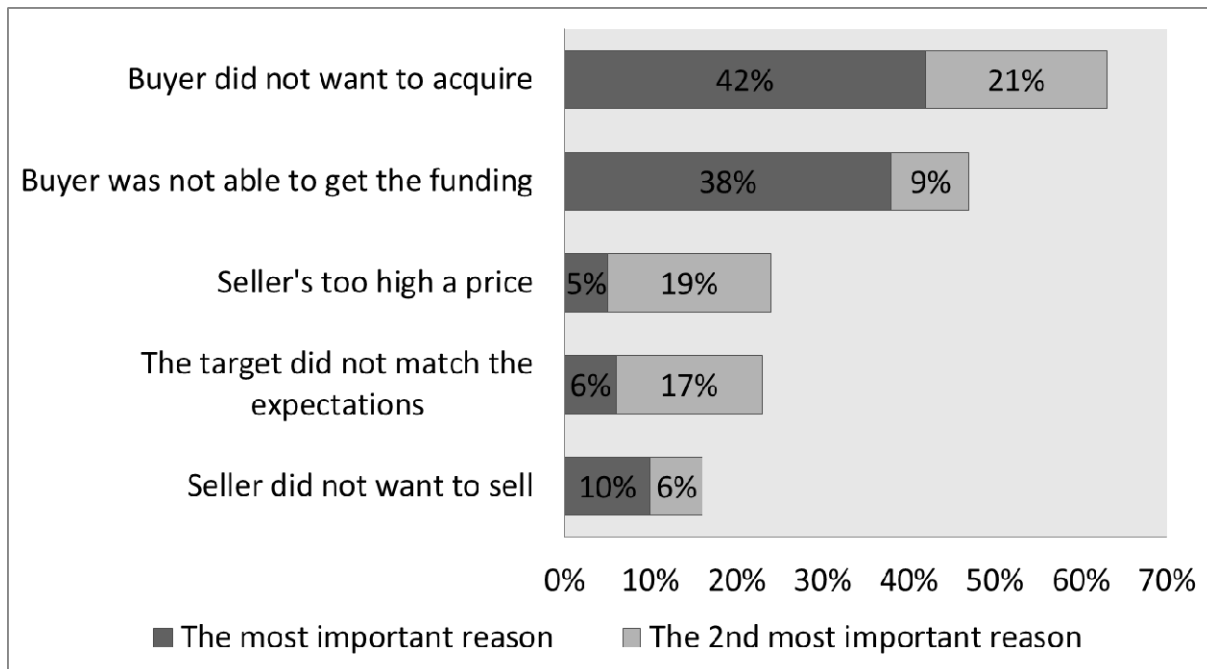

Figure 2: Main reasons for the fall of business transfer – Seller’s perspective



Altogether 83 percent of the buyers but only 55 percent of the sellers would not do anything differently in the negotiations, were they to start over now ($p=.003$). Learning from transfer negotiations seems cumulative. The respondents with previous experience would more often do something differently than those for whom this was the first such process. Of those who would do something differently, both sellers and buyers would plan the process

better and use more external expertise. Also, many of the sellers would adjust their asking price and try to move the process along faster. Ultimately, however, 39 percent of the buyers and 18 percent of the sellers were either satisfied or very satisfied with the fact that the negotiations failed and the transfer was unfinished.

CONCLUSIONS

The **main contribution** of the study is that it examines the reasons for failure of business transfer negotiations among small businesses. In unfinished business transfers the problems are more numerous and the gaps between the views of the two negotiating parties are wider than in successfully concluded business transfer negotiations. The results highlight the importance of unfinished small business transfers as an essential element of a dynamic business transfer market; a substantial share of the potential buyers and sellers are satisfied with the outcome even though the transfer did not occur.

Timing is an important factor in many unfulfilled business acquisitions. The overall picture is that sellers are leaving out late. As business negotiations start to take place in a difficult time, the chance of failure is much greater. The best time for business transfer is when it is doing well. As business negotiations start to take place during downturn or regression, the chance of a failure is much greater. The right timing can be viewed with regard to the industry, business or entrepreneur. The overall outlook for the industry is part of an overall picture of buyers and financiers as the viability of a trade item; The fading industry does not temptate byer, with a loss making results it is difficult to convince buyers of future opportunities. It is much easier to sell a business after a few successful years.

The study also has a number of **managerial implications**. First, several factors usually contribute to the failure of business transfer negotiations. For the buyer, the negotiations are foremost a process of familiarizing oneself with the target business as the negotiations proceed. Second, high asking prices are a serious problem and unrealistic initial valuations can cause failure in early phases. A seller may have a strong bond to his/her business, which makes it difficult to give up on the company under the terms on which the buyer can found. In addition to the oversized price request, the tail can lead, for example, to terms of trade that limits excessive potential buyers or limit potential buyers' ability to develop their business according to their own needs. Financing is one of the challenges in implementing ownership changes. However, it should be noted that in some of the cases it seems to be used as an excuse, when there is no real reason for the seller to express himself. This is also reflected in the fact that sellers consider financing more often as the cause of the ending of negotiations. Funders may have unsubstantiated grounds for refusing to grant funding. In addition to the industry's overall prospects the financiers will also weigh the viability of the purchase item in the hands of the new buyer. Ultimately, the financing solution is always unique and complex case.

Third, the results of this study indicate that a large part of the unlisted companies are practically non-viable. Incapability for surviving is one of the most important reasons why a company cannot be sold. Already in previous studies, it has been suggested that the company should be developed until the time of sales. The results of this study strongly support this view. Overall, it is understandable and acceptable that some companies cannot find a new owner. The elimination of non-viable companies is part of the business dynamics.

Fourth, once negotiations begin, every effort should be made to move them along efficiently. Negotiations that stall should be cut off without undue delay. The timescales for the business transfer process are also relevant. During the process, long-term potential buyers are likely to decline and the price is likely to fall. On the other hand, the seller is advised to seek a tight timetable in negotiation with a single buyer, and, on the other hand, try, if possible, to get more buyers to consider purchasing. Negotiations with many buyers need more resources, but a fast and efficient process, on the other hand, will also save time and lead to a more satisfactory result. The results indicate that in business transfer negotiations, too much time and resources are used in the cases that are unfavorable for both. For all parties concerned, it would be desirable for the process to proceed - and, if necessary, to end unsuccessful - in a timely manner. The negotiation process is typically going wrong when (1) trust does not seem to arise, when (2) differences in views on the purchase price, subject or conditions are significant, if the agreed

timetables are repeatedly not met (3) either party accuses the other party and (4) if there are several problems that only one party tries to find a solution. In such a situation, consideration should be given to breaking the negotiations. The time to negotiate can be better used to develop a sales target or to find a more suitable purchase object.

Fifth, the utilization of business transfer experts in the transfer negotiations is recommended. It is recommended that when selecting an expert, the seller / buyer will be assured by the recommendations that the expert is experienced and knowledgeable. The use of external experts is reduced by the fact that there is no information on the availability of expert services. The level of expertise used in the process varies. This is challenging, especially for inexperienced, first time buyers and sellers who negotiate business acquisitions. For example, valuation is a challenging task where external expertise is most often needed, but the expertise of the advisor and the quality of the advice is of great importance. Here and also in previous studies, it has been found that highly educated and experienced mergers make more use of experts even though they have their own skills and experience.

A proposal for **further research** would be to follow-up on the unfinished business transfer processes, that is, to see how the buyers and sellers fare with their possible new negotiations. A longitudinal follow-up after 1–2 years could discover whether the targets examined here have later found buyers, and the buyers now unable to make a business transfer, targets to acquire.

REFERENCES

- Aiello, R. & Watkins, M. 2000. The fine art of friendly acquisition. *Harvard business review* 78 (6), 100–107.
- Baker, H., Dutta, S., Saadi, S. & Zhu, P. 2012. Are good performers bad acquirers? *Financial management* 41 (1), 95–118.
- Chatterjee, S. 2009. The keys to successful acquisition programmes. *Long range planning* 42 (2), 137–163.
- Davidsson, P. 2003. “The Domain of Entrepreneurship Research: Some Suggestions.” In *Cognitive Approaches to Entrepreneurship Research*, edited by J. A. Katz and D. A. Shepherd, 315–372. Oxford: Elsevier Science.
- Dyer, J., Kale, P. & Singh, H. 2004. When to ally & when to acquire. *Harvard business review* 82 (7/8), 108–115.
- Erzberger, C., and G. Prein. 1997. “Triangulation: Validity and Empirically-Based Hypothesis Construction.” *Quality & Quantity* 31 (2): 141–154.
- Gomes, E., Angwin, D., Weber, Y. & Tarba, S. 2013. Critical success factors through the mergers and acquisitions process: Revealing pre- and post-M&A connections for improved performance. *Thunderbird international business review* 55 (1), 13–35.
- Graebner, M., Eisenhardt, K. & Roundy, P. 2010. Success and failure in technology acquisitions: Lessons for buyers and sellers. *Academy of management perspectives* 24 (3), 73–92.
- Hurmerinta-Peltomäki, L., and N. Nummela. 2006. “Mixed-methods in International Business Research: A Value-added Perspective.” *Management International Review* 46 (4): 439–459.
- Langford, R. & Brown, C. 2004. Making M&A pay: lessons from world’s most successful acquirers. *Strategy and leadership* 32 (1), 5–14.
- Larsson, R. & Finkelstein, S. 1999. Integrating strategic, organizational, and human resource perspective on mergers and acquisitions: A case survey of synergy realization. *Organization science* 10 (1), 1–26.

- Marks, M. & Mirvis, P. 2001. Making mergers and acquisitions work: Strategic and psychological preparation. *Academy of management executive* 15 (2), 80–92.
- Marks, M. & Mirvis, P. 2011. Merge ahead: a research agenda to increase merger and acquisition success. *Journal of business and psychology* 26 (2), 161–168.
- Molina-Azorín, J. F., M. D. López-Gamero, J. Pereira-Moliner, and E. M. Pertusa-Ortega. 2012. “Mixed methods Studies in Entrepreneurship Research: Applications and Contributions.” Review of *Entrepreneurship & Regional Development* 24 (5–6): 425–456.
- Rovit, S., Harding, D. & Lemire, C. 2004. A simple M&A model for all seasons. *Strategy and leadership* 35 (2), 18–24.
- Seth, A., Song, K. & Pettit, R. 2002. Value creation and destruction in cross-border acquisitions: An empirical analysis of foreign acquisitions of US firms. *Strategic management journal* 23 (10), 921–940.
- Tall, J. 2014. *Yrityskauppa ja strateginen uudistuminen*. Vaasa: Vaasan yliopisto. *Acta Wasaenia* 305. *Liiketaloustiede, johtaminen ja organisaatiot* 124. Väitösk.
- Teerikangas, S. 2012. Dynamics of acquired firm pre-acquisition employee reactions. *Journal of management* 38 (2), 599–639.
- Uhlaner, R. & West, A. 2008. Running a winning M&A shop. *McKinsey quarterly* 2, 106–113.
- Varamäki, E., Heikkilä, T., Tall, J. & Tornikoski, E. 2011a. Eteläpohjalaiset yrittäjät liiketoimintojen ostajina, myyjinä ja kehittäjinä. [Verkkajulkaisu]. Seinäjoki: Seinäjoen ammattikorkeakoulu. Seinäjoen ammattikorkeakoulun julkaisusarja B. Raportteja ja selvityksiä 52. [Viitattu 29.11.2013]. Saatavana: <http://theseus.fi/bitstream/handle/10024/30761/B52.pdf?sequence=1>
- Varamäki, E., Heikkilä, T., Tall, J., Länsiluoto A. & Viljamaa, A. 2012a. Ostajien näkemykset omistajanvaihdoksen toteuttamisesta ja onnistumisesta. [Verkkajulkaisu]. Seinäjoki: Seinäjoen ammattikorkeakoulu. Seinäjoen ammattikorkeakoulun julkaisusarja B. Raportteja ja selvityksiä 61. [Viitattu 29.11.2013]. Saatavana: <http://publications.theseus.fi/handle/10024/45396>
- Varamäki, E., Heikkilä, T., Tall, J., Viljamaa, A. & Länsiluoto, A. 2013a. Omistajanvaihdoksen toteutus ja onnistuminen ostajan ja jatkajan näkökulmasta. [Verkkajulkaisu]. Seinäjoki: Seinäjoen ammattikorkeakoulu. Seinäjoen ammattikorkeakoulun julkaisusarja B. Raportteja ja selvityksiä 74. [Viitattu 29.9.2014]. Saatavana: <http://theseus.fi/bitstream/handle/10024/64381/B74.pdf?sequence=1>
- Varamäki, E., Tall, J., Heikkilä, T. & Sorama, K. 2011b. Omistajanvaihdosasiantuntijuus ja sen kehittäminen 2011. Helsinki: Omistajanvaihdosten valtakunnallinen koordinointi, TEM.
- Varamäki, E., Tall, J., Sorama, K., Länsiluoto, A., Viljamaa, A., Laitinen, E. K., Järvenpää, M. & Petäjä, E. 2012b. Liiketoiminnan kehittyminen omistajanvaihdoksen jälkeen: Case-tutkimus omistajanvaihdoksen muutostekijöistä. [Verkkajulkaisu]. Seinäjoki: Seinäjoen ammattikorkeakoulu. Seinäjoen ammattikorkeakoulun julkaisusarja A. Tutkimuksia 9. [Viitattu 29.11.2013] Saatavana: <http://publications.theseus.fi/handle/10024/45396>.
- Varamäki, E., Tall, J., Sorama, K. & Katajavirta, M. 2012c. Valtakunnallinen omistajanvaihdosbarometri 2012. Helsinki: Omistajanvaihdosten valtakunnallinen koordinointi, TEM.
- Varamäki, E., Tall, J. & Viljamaa, A. 2013b. Business transfers in Finland – sellers’ perspective. Proceedings of 13th Annual Conference of the European Academy of Management, 26–29 June 2013, Istanbul, Turkey.

Varamäki, E., Tall, J., Viljamaa, A., Sorama, K., Länsiluoto, A., Petäjä E. & Laitinen, EK. 2013c. Omistajanvaihdos osana liiketoiminnan kehittämistä ja kasvua – tulokset, johtopäätökset ja toimenpide-ehdotukset. [Verkkajulkaisu]. Seinäjoki: Seinäjoen ammattikorkeakoulu. Seinäjoen ammattikorkeakoulun julkaisusarja B. Raportteja ja selvityksiä 76. Saatavana: https://www.theseus.fi/bitstream/id/209266/B76_.pdf

Very, P. & Schweiger, D. 2001. The acquisition process as a learning process: evidence from a study of critical problems and solutions in domestic and cross-border deals. *Journal of world business* 36 (1), 11–31.

Westhead, P., and M. Wright. 2000. "Introduction." In *Advances in Entrepreneurship*, edited by P. Westhead and M. Wright, xii–xcvi. Cheltenham: Edward Elgar.

AUSTRALIAN KNOWLEDGE WORKERS' PRODUCTIVITY: WHAT MATTERS?

Maria Estela Varua, Mathew Bright and Margaret Moussa
Western Sydney University

ABSTRACT

Given the growing significance of 'Knowledge Work' in industrial societies, scholars have emphasized the need to understand the factors affecting knowledge workers' productivity. This study is designed to determine the effect that work design and other external factors has on the productivity of knowledge workers in the Australian information technology sector in both the private and public sector. The study found that, knowledge sharing, motivational characteristics, organisational characteristics, social characteristics and technologies are key determinants of knowledge workers' productivity.

Keywords: knowledge worker, subjective approach, work design, knowledge sharing, productivity.

INTRODUCTION

Peter Drucker was the first to term the phrase 'knowledge worker' in the 1950's and accurately predicted the turn from a manual worker based economy in 1950 to a knowledge based economy in the 21st century (Drucker 1999). Many economists have argued that the future prosperity of industrial economies and the world economy as a whole will depend on how business and governments manage and promote the productivity of their knowledgeable workers (Drucker 1998, Antikainen and Lönnqvist 2005).

Given the growing significance of 'Knowledge Work' in industrial societies, scholars have emphasized the need to understand the factors affecting knowledge workers' productivity. At the same time, a large body of literature discusses both the difficulty in defining knowledge workers' productivity and in measuring or determining the factors affecting it. These problems have been attributed to the intrinsically changing and intangible nature of knowledge work itself. In light of this, key reviews of the literature have indicated the need for more research focusing on the quality of knowledge work and its multidimensionality. Methodological discussion has suggested that what might be fruitful for researchers in this regard is the adoption of (what are called) "subjective" and "work design" approaches. Subjective approaches draw conclusions about knowledge workers' productivity from the perceptions and experiences of workers themselves while job design approaches focus on varied and specific processes.

In an attempt to integrate the "subjective" and "work design" approaches, this study uses Morgeson and Humphrey's (2006) 'work design' model to examine the productivity of information technology workers in Australia. Morgeson and Humphrey (2006) distilled 18 variables from thousands of studies to examine the relation between work design and job satisfaction. However Yusof *et al.* (2012) suggests that their approach may be fruitful for understanding productivity and the productivity of knowledge workers specifically. The present study nonetheless adapts Morgeson and Humphrey (2006) to include additional variables identified by Mahmood and Ali (2011) and others as significantly affecting knowledge workers' productivity.

The resultant 'hybrid' model includes motivation, social and organisational characteristics from Morgeson & Humphrey (2006) as well as knowledge sharing, rewards, technology and CICO from Mahmood and Ali (2011). This model disperses the dimensions of 'organisational culture', treated as a distinctive variable by Mahmood and Ali (2011), into the other social and organisational characteristics. The hybrid model moreover adds job security as an organisational characteristic. This has been included in response to studies indicating the importance of job

security for productivity through its effects on organisational commitment, psychological well-being and family life (Berntson, Näswall & Sverke 2010). While this applies to workers' generally, Cheng and Chan (2008) observe that job security is more likely to affect the motivation and commitment of highly skilled workers.

The present study focuses on Australia given both the stated need to understand knowledge workers' productivity in this context and the scarcity of such methodologically considered studies to date. Search of the literature reveals that there are two papers that empirically considered knowledge work in Australia in terms of processes and workers' experiences. However neither of these studies attempts to directly address the question of knowledge workers' productivity. Moreover, neither appears to consider the range of variables identified as significant in the knowledge worker productivity literature.

DETERMINANTS OF PRODUCTIVITY

Theorists working within the framework of the 'Knowledge Economy' regard the productivity of knowledge workers as the crucial issue for contemporary and future economies (Rüdiger & McVerry 2007). These writers emphasize that nurturing and improving the knowledge and skills of such workers is likely to have the equivalent impact on productivity in the 21st century that the process of capital mechanization had in the 19th and 20th centuries (Drucker 1994). While the productivity of knowledge workers is understandably integral to a theory of the 'Knowledge Economy', its empirical importance is at any rate reflected in the emphasis placed upon it by multifactor productivity analysts generally.

In the context of the Australian economy the importance of identifying and understanding the factors underlying knowledge workers productivity (KWP) must be considered in light not only of the growing proportion of knowledge workers to other workers but also in light of Australia's apparent lacklustre productivity performance by global and recent historical standards. While most of the industrialised world has had lower productivity growth rates compared to the 1990's, Australia's productivity over the previous decade has been relatively weak compared to other comparable OECD countries (Productivity Commission 2013). Over 2003-10 period Australia has posted neutral or negative productivity growth rates.

In this context the importance of understanding the productivity of knowledge workers is reflected in the fact that over the past decade, industries with high concentrations of such workers (telecommunications, media, information and mining) appear to be the worst productivity offenders. The exception appears to be the finance industry (Productivity Commission 2013). These statistics could be interpreted to suggest that, despite increased spending in areas traditionally associated with knowledge work in Australia, there is a considerable lack of understanding of the factors underpinning KWP (Rüdiger & McVerry 2007). Alternatively, these statistics may reflect the failure of traditional multifactor productivity models to capture and measure the actual productivity of knowledge workers and by extension, trends in Australia's productivity generally. To adequately consider either postulate, we need firstly to address the widely acknowledged lack of consensus on and difficulty in both the defining and measuring KWP (Ramirez & Nembhard 2004).

THEORETICAL FRAMEWORK

Knowledge workers refers to workers that are engaged in the "(1) the creation new knowledge; (2) application of existing knowledge to current problems; (3) the teaching of knowledge; and 4) using knowledge within the production process" (Kelloway 2000). This definition was chosen as it achieves to overcome the problems of the previous definitions used in literature. It places emphasis on the aspects of work that a worker is engaged, not the education or occupation of the worker. It also doesn't restrict knowledge worker to minor individual characteristics, but also still recognises that creativity and knowledge creation is an integral part of some knowledge workers (Kelloway 2000). Lastly another advantage of this definition is it places the use of knowledge at the very centre of the definition of knowledge worker, distinguishing between a knowledge worker and manual worker.

A two staged ordered logit model is used to address the fact that a highly significant variable, the CICO, affects **knowledge worker productivity (KWP)** only indirectly, through its impact on knowledge sharing (Lemon & Sahota 2004). However in this first stage, the influence of the other broadly defined characteristics on knowledge sharing is also considered. The inclusion here of the full range of broadly defined characteristics acknowledges both the disproportionate influence of knowledge sharing on productivity (Mahmood & Ali 2011) as well as the documented influence of the other broad groups of variables on knowledge sharing itself (Lin 2007). Mathematically the model is specified as follows:

$$KS_i = \beta_1 + \beta_2 Mot_i + \beta_3 Org_i + \beta_4 Soc_i + \beta_5 R/I_i + \beta_6 Tech_i + \beta_7 CICO_i + e_i \quad (1)$$

$$KWP_i = \beta_1 + \beta_2 Mot_i + \beta_3 Org_i + \beta_4 Soc_i + \beta_5 R/I_i + \beta_6 Tech_i + \beta_7 KS_i + e_i \quad (2)$$

Knowledge or information sharing (KS) refers to the provision of task information to help others and to collaborate with others to solve problems, develop new ideas, or implement policies or procedures (Cummings 2004). Mahmood and Ali (2011) review of the literature emphasizes the disproportionate importance of knowledge sharing relative to other factors affecting knowledge workers' productivity. The importance of knowledge sharing is reflected in the fact that knowledge work is typically and often necessarily carried out by workers in collaboration and also in the increasing amount of information given to them (Bosch-Sijtsema, Ruohomäki & Vartiainen 2009;). The literature also highlights the significant extent to which knowledge sharing itself is affected by other variables specified in this study.

Motivational characteristics (Mot) are identified by a number of studies to have a significant positive relationship with worker's productivity (Grant 2008). Morgeson and Humphrey (2006) divide motivational characteristics into task characteristics and the knowledge requirements of work. Tasks characteristics are primarily concerned with how work is accomplished, with the range and specific nature of the tasks involved. On the other hand knowledge characteristics reflect the kinds of knowledge, skills, and ability demanded of individuals in the process of their work.

Contextual or Organisational (Org) refer to the context in which work is undertaken. In Morgeson & Humphrey's (2006) model these include ergonomics, the level of physical activity required, work conditions and the type and availability of equipment (Morgeson & Humphrey 2006, p. 1324). The consensus of a large number of studies is that despite variations in personal thresholds, a greater degree of required physical exertion negatively impacts the performance of workers. Moreover, although knowledge work generally requires less physical exertion than manual work, the physical demands on some knowledge workers may still affect productivity.

Social (Soc) Characteristics of work and the productivity of knowledge workers: refers to feedback others in the organisation, social support, outside communication and interdependence address the fact that work is performed in a broader social environment. Theorists have argued that knowledge workers regard such characteristics as affecting the quality of their work to the same degree as organisational and motivational factors (Rhoades & Eisenberger 2002). Whether feedback is valued more from managers than from co-workers may depend on the manner in which it is delivered and on other social factors in the organisation (London 2003).

Rewards and incentives (R/I) include monetary rewards and opportunities for career enhancement, the latter being significant particularly in the early and middle stages of working life (Kaarboe & Olsen 2006). Overall most of the literature on monetary incentives concludes that they do increase performance across a wide variety of tasks (Kaarboe & Olsen 2006). However it stipulates that the relationship varies with the type of task (Kaarboe & Olsen 2006).

Technology (Tech) involves the use of equipment, as defined by Humphrey and Morgeson (2006). However it also involves software such as virtual technology (Carr & Lu 2007). Some studies note a strong and positive connection between the productivity of knowledge workers and the availability and use of technology. This relationship is based essentially on the enhancement of information sharing and flexibility of work schedules (Carr & Lu 2007; Haner et al. 2009).

The culture of innovation and creativity (CICO) refers to the relative degree to which an organisation encourages its employees to take risks to find better way of doing things (Ahmed 1998). We have seen that innovation and creativity are often integral to defining knowledge work (Kelloway & Barling 2000). In the context of a 'knowledge economy', the capacity to innovate is moreover inextricable from the survival of firms (Drucker 1994). The CICO has the effect of improving knowledge sharing within a firm. At the same time, as noted, the positive effects of innovation on KWP necessarily occur through knowledge sharing (Haas Hansen 2007).

The aim here is to identify factors that influence **KS** and **KWP**. A two staged ordered logit model is used to address the fact that **CICO**, affects **KWP** only indirectly, through its impact on knowledge sharing (Lemon & Sahota 2004). In the first stage, the influence of the other broadly defined characteristics on knowledge sharing is also considered. The inclusion here of the full range of broadly defined characteristics acknowledges both the disproportionate influence of knowledge sharing on productivity (Mahmood & Ali 2011) as well as the documented influence of the other broad groups of variables on knowledge sharing itself (Lin 2007).

DATA DISCRIPTION

Data was obtained from the distribution of a questionnaire to information technology workers in Australia. Participants were invited to complete a survey and to respond to open-ended questions. The survey required participants to answer a series of statements on a scale from strongly agree to strongly disagree. It was piloted by a number of academics to ensure the quality and understand ability of the questions. Based on the comments and suggestions of the academics many of the questions were removed, changed or added. As noted, the inclusion of open ended questions is important given the possibility of mixed results and diminishing returns for some variables. Open-ended questions are also important given the recognised intangibility of knowledge work productivity.

Data was collected online and in person over a 6 week period. Overall 94 questionnaires were returned from nine private organisations and seven public organisations. One advantage of the relatively wide response across organisations is that conclusions will not be confined to one or two specific situations. However, the relatively sparse response within each organisation implies limited opportunity to compare the responses of individuals in highly similar environments.

Respondents' Characteristics

Of the 91 respondents 51 (57.95%) were male and 37 (42.05%) were female and 3 respondents did not answer the question. Six (6.74%) of the participants were aged 18-24, 37 (41.57%) were aged 25-34, 27 (30.34%) were aged 35 to 44, 11 (12.36%) were aged 45-54 and 8 (8.995%) were aged 55+ and 2 respondents did not answer.

The length of time that respondents had worked in IT was also determined. Forty- five (49.95%) of the respondents stated that they had been IT workers for the past 5-10 years, 35 (38.46%) stated that they had been an IT worker for 10-20 years and 11 (12.09%) stated they had been IT workers for 20+ years as shown above.

Lastly, when asked about their educational achievement only one (1.12%) of respondents stated that they had not graduated from secondary school, 15 (16.85%) indicated that their highest achievement was a secondary school degree or equivalent, 47 (52.81%) had a Bachelor's degree, 20 (22.47%) had a postgraduate degree while 2 (2.25%) had a doctoral qualification. Four (4.49%) stated choose the category 'other'.

Age Distribution and Number of Years in Current Industry

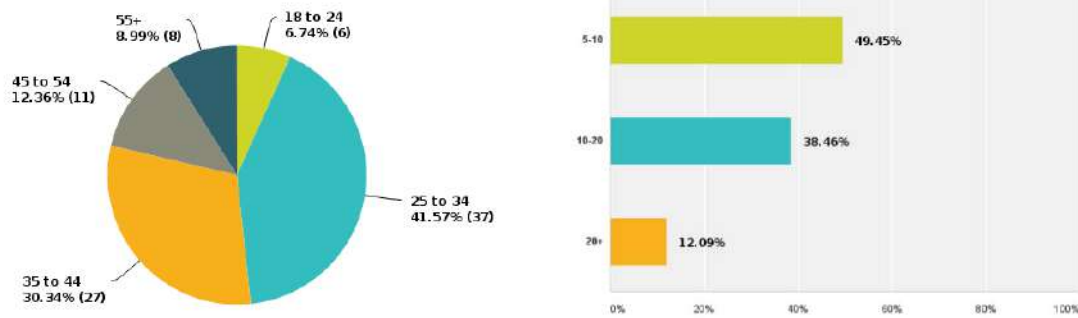

Validity of the Survey Data

Using the Cronbach Alpha to test for internal consistency, all variables were found to meet the cut off value of 0.7 (Mahmood & Ali 2011). Further, the Bartlett test has been satisfied, with all variables having a value of less than 0.05. A test for multicollinearity run on all models indicated that the variables were weakly correlated. None of the variables had a value higher than 0.65. Moreover, tests for heteroskedasticity indicated that all the models were homoskedastic. Overall the data has been found to be valid and consistent

DISCUSSION OF RESULTS

Testing the effects on knowledge sharing of the explanatory variables identified in equation (1), we find that motivational characteristics (Mot), social characteristics (Soc), technology (Tech) and CICO are positively significant (see Table 1). The results show that if the levels of motivational characteristics, social characteristics; CICO and technology were to each increase then the probability of a higher level of knowledge sharing increases. Organisational (Org) characteristics and rewards and incentives (R/I) were found not to be significant.

As in stage 1, social and motivational characteristics have a direct positively significant effect on KWP, as does knowledge sharing. On the other hand organisational characteristics have a significant but negative effect. Within the context of the Model we can infer that the negative effect of organisational factors on KWP is unrelated to the capacity for knowledge sharing. However, rewards and incentives and technology appear to be insignificant. This suggests that technology impacts on KWP only indirectly, through its effects on knowledge sharing.

The results presented in Table 1 suggest that task related to motivational characteristics positively impact on both KS and KWP both directly and indirectly through knowledge sharing. When the individual responses were investigated further, the results reveal that task significance and task identity impact directly on KWP but do not appear to affect knowledge sharing. Work Autonomy is found to be the only significant motivational variable affecting both knowledge sharing and KWP.

The results further suggest that organisational factors are insignificant for knowledge sharing yet have a directly detrimental effect on KWP. It appears that the negative effect of ergonomics- the designing of work in relation to employees' posture and general movement and the insignificance overrides the positive effects of job security in the results for this broad category variable org.

Table 1: Ordered Logit Results

Variable Name	Dependent Variable	
	KS	KWP
Knowledge Sharing (KS)		1.142
		(2.74)***
Motivational Characteristics (Mot)	1.2532	1.114
	(3.32)***	(2.97)***
Organisational Characteristics (Org)	-0.0601	-1.1826
	(-0.18)	(-3.44)***
Social Characteristics (Soc)	0.6677	-0.708
	(2.13)***	(2.12)***
Technology (Tech)	0.9016	0.1159
	(2.52)***	(-0.42)
Rewards/Incentives (R/I)	0.3298	-0.3701
	-1.48	(-1.68)
CICO	0.6076	
	(2.22)***	
Log-likelihood	-62.3487	-81.4832
(P-Value)	(0.00)***	(0.00)***

Note: ***, **, * significant at 1%, 5% and 10% respectively.

Social characteristics are highly positively significant for the knowledge sharing. Social support appears to impact on KWP directly and positively while the level of interdependence had a negative productivity effect. Further, the results indicate that technology has a positively significantly effect on KWP indirectly, through knowledge sharing. In contrast to the findings of some previous literature, rewards and incentives appeared overall not to significantly impact on KWP.

The significance of factors other than work design

Answers to the open-ended questions included in the survey suggest that non-work factors such as family life and personality are highly significant for KWP. If this is the case, then future models need to include broad categories beyond work design and to consider responses to work-related variables in light of personal characteristics such as age and gender. Further, organisational culture and management practices appear to impact in a more complex and significant manner than is suggested by survey responses. It would seem that the productivity impact of these factors is not adequately captured in narrowly classifying them as social and organisational characteristics of work design.

CONCLUSIONS

Interestingly, the results indicated that knowledge workers regarded knowledge sharing (KS) as significantly and positively impacting on KWP. Moreover, knowledge sharing was not particularly emphasized in the open-ended

suggestions for improving future productivity. Respondents' failure to elaborate on the importance of knowledge sharing in the open-ended questions may possibly be due to this factor being integral to, pervasive and implied in much of their daily activity.

With the qualification that they reflect the perceptions and experiences of specifically information technology workers in Australia, the results of this study suggest the following measures could improve existing KWP.

The need for facilitating knowledge sharing and the related importance of fostering a culture of innovation and creativity within organisations: In line with the suggestions of Mahmood and Ali (2011) and others, the results show that knowledge workers regarded knowledge sharing as extremely important for improving their productivity. However, only 49.45% of survey respondents believed that knowledge was shared to any significant degree within their organisation. Moreover 16.58% appeared to regard knowledge sharing within their organisation to be inadequate. If these results can be generalised, then this suggests that over 50% of organisations could benefit from implementing or upgrading facilities and programs that enhance knowledge sharing. Improving the organisation's culture of innovation and creativity may be the key policy variable in this regard.

Improving knowledge workers' motivation by facilitating workplace autonomy and enhancing task identity: The results of this study indicated that only task based motivational characteristics affected KWP and that of these, autonomy was the most significant. However only 35% of respondents believed they had autonomy within their workplace, while 20% thought they were rarely granted this. This suggests that, to enhance the productivity of their knowledge workers, most organisations could implement factors facilitating workers' autonomy in decision making, work scheduling and task execution.

The importance of organisational factors: The negative, significant impact of organisational factors in Models 1 and 2 suggests need to further consider the effect of factors such as ergonomics on KWP.

The need for approaches that improve the workplace social environment and enhance communication with organisations and individuals outside the firm: The survey results and answers to open-ended questions indicate these social characteristics are significant for both knowledge sharing and KWP directly. However, when asked whether they believed their organisation had a good social environment, only 30% of KWS agreed, while 35% said it did not. Moreover only 55% of respondents felt they had adequate social support at work. These results should be considered in conjunction with the emphasis placed on the effects of organisational culture, bullying and harassment in the answers to the open-ended questions.

Programs and approaches facilitating work-life balance: The open-ended questions commonly emphasized this non-work design factor as significantly affecting their productivity at work. If generalised, these responses suggest a need for organisations to consult their employees on how work, family, community and other responsibilities can be better integrated.

These conclusions must however be qualified given the limitations of this study.

REFERENCES

- Berntson, E., Näswall, K. & Sverke, M. (2010). The moderating role of employability in the association between job insecurity and exit, voice, loyalty and neglect. *Economic and Industrial Democracy*, 31(2), 215-30.
- Bosch-Sijtsema, P., Ruohomäki, V., & Vartiainen, M.(2009). Knowledge work productivity in distributed teams. *Journal of Knowledge Management*. 13 (6), 533-46.
- Carr, P. & Lu, Y. (2007). Information technology and knowledge worker productivity: A taxonomy of technology crowding. *Information Technology*, 12, 31-2007.
- Cheng, G & Chan, D. (2008). Who suffers more from job insecurity? A meta-analytic review. *Applied Psychology*, 57(2), 272-303.
- Cummings, J.(2004). Work groups, structural diversity, and knowledge sharing in a global organization. *Management Science*, 50(3), 352-64.
- Drucker, P. (1994). *Post-capitalist society*. HarperCollins. New York.
- Drucker, P.(1999). Knowledge-worker productivity. *California Management Review*, 41(2), 79-94.
- Grant, A.(2008). The significance of task significance: Job performance effects, relational mechanisms, and boundary conditions. *Journal of Applied Psychology*, 93(1), 108.
- Haas, M. & Hansen, M.(2007). Different knowledge, different benefits: Toward a productivity perspective on knowledge sharing in organizations. *Strategic Management Journal*, 28(11), 1133-1153.
- Kaarbøe, O. & Olsen, T.(2006). Career concerns, monetary incentives and job design. *The Scandinavian Journal of Economics*, 108(2), 299-316.
- Kelloway, E. & Barling, J. (2000). Knowledge work as organizational behavior. *International Journal of Management Reviews*, 2(3), 287-304.
- Lemon, M. & Sahota, P.(2004). Organizational culture as a knowledge repository for increased innovative capacity. *Technovation*, 24(6), 483-98.
- Lin, S. & Hsieh, A. (2002). Constraints of task identity on organizational commitment. *International Journal of Manpower*, 23(2), 151-65.
- Mahmood, S. & Ali, B. (2011). An empirical investigation on knowledge workers productivity in telecom sector of Pakistan. *Information Management and Business Review*, 3(1), 27-38.
- Morgeson, F. & Humphrey, S. (2006).The work design questionnaire (WDQ): Developing and validating a comprehensive measure for assessing job design and the nature of work. *Journal of Applied Psychology*, 91(6), 1321.
- Ramírez, Y. & Nembhard, D. (2004). Measuring knowledge worker productivity: A taxonomy. *Journal of Intellectual Capital*, 5(4), 602-28.

Ramirez, Y. & Steudel, H. (2008). Measuring knowledge work: The knowledge work quantification framework. *Journal of Intellectual Capital*, 9(4), 564-84.

Rüdiger, K. & McVerry, A. (2007). Exploiting Europe's knowledge potential: 'Good work' or 'could do better'. *A report prepared for the Knowledge Economy programme*, viewed 17th January 2014, <http://www.theworkfoundation.com/DownloadPublication/Report/53_53_exploiting_Europe.pdf>.

MULTIVARIATE REGRESSION: A VERY POWERFUL FORECASTING METHOD

A. Vasilopoulos
St. John's University, USA

ABSTRACT

Regression Analysis is at the center of almost every Forecasting technique, yet few people are comfortable with the Regression methodology. We hope to greatly improve the level of comfort with this article. Here we briefly discuss the theory behind the methodology and then outline a step-by-step procedure, which will allow almost everyone to construct a Regression Forecasting function for both the linear and Multivariate case. The Linear Regression is shown to be a special case of the multivariate problem. Also discussed, in addition to model formation and estimation, is model testing (to establish statistical significance of factors) and the Procedure by which the final regression equation is obtained from the estimated equation. The Final Regression Equation is retained and used as the forecasting equation. A hand solution is derived for a relatively small sample problem, and this solution is compared to the MINITAB-derived solution to establish confidence in the statistical tool, which then can be used exclusively for larger problems.

Keywords: Multivariate Regression, Matrix Algebra, Linear Regression, Estimated Equation, Final Equation.

INTRODUCTION AND MODEL ESTIMATION FOR THE MULTIVARIATE PROBLEM

Multivariate Regression analysis, in which an equation is derived that connects the value of one dependent variable (Y) to the values of p independent variables X_1, X_2, \dots, X_p , starts with a given multivariate data set and uses the Least Squares method to assign the **best** possible values to the unknown multipliers found in the model we wish to estimate. The multivariate data set used to estimate the multivariate model consists of n p-tuples of values:

$$(x_{11}, x_{21}, \dots, x_{p1}, y_1), (x_{12}, x_{22}, \dots, x_{p2}, y_2), \dots, (x_{1n}, x_{2n}, \dots, x_{pn}, y_n)$$

1) Estimation of the Model

The multivariate model is given by:

$$Y = a + b_2 X_2 + b_3 X_3 + \dots + b_p X_p \quad (1)$$

$$\text{or } Y = b_1 X_1 (= 1) + b_2 X_2 + b_3 X_3 + \dots + b_p X_p \quad (2)$$

Note that the first 2 terms of the multivariate model given by equation (1) are identical to the linear model $Y = a + bX$ and in equation (2) we introduced a variable X_1 , whose value is always equal to 1 (if we wish the model to have a constant term), to make the handling of the multivariate model easier, using matrix operations. Note also that the 'a' in equation (2) is set equal to b_1 in equation (3). To estimate the Multivariate model, we use the Least Squares Methodology, which calls for the formation of the Quadratic function:

$$Q(b_1, b_2, \dots, b_p) = \sum_{i=1}^n [y_{actual_i} - y_{Multivariable\ function_i}]^2$$

$$= \sum_{i=1}^n [y_i - b_1 - b_2 X_{i1} - b_3 X_{i2} - \dots - b_p X_{ip}]^2 \quad (3)$$

To derive the “Normal Equations for the Multivariate model”, from which the values of: $b_1, b_2, b_3, \dots, b_p$ are derived, we take partial derivatives of the $Q(b_1, b_2, b_3, \dots, \text{and } b_p)$ function with respect to $b_1, b_2, b_3, \dots, \text{and } b_p$ respectively, and set each equal to 0; i.e. we obtain, and set equal to zero:

$$\frac{\partial Q}{\partial b_1} = 0$$

$$\frac{\partial Q}{\partial b_2} = 0$$

$$\dots$$

$$\frac{\partial Q}{\partial b_p} = 0 \quad (4)$$

However, when attempting to solve the set of equations (4) algebraically, the results are very complicated, and it is advisable to state the resulting “Normal equations” in a matrix form, by which they are stated as:

$$(X^t X)b = (X^t Y) \quad (5)$$

where: X = Matrix formed from the values of the p independent variables (X has n rows and p columns, or X is a $n \times p$ matrix),

X^t = Transposed matrix X (X^t has p rows and n columns, or X^t is a $p \times n$ matrix)

Y = Column Vector (or $n \times 1$ matrix) of the given Y values

b = Column Vector (or $p \times 1$ matrix) of the unknown multipliers $b_1, b_2, b_3, \dots, b_p$

The Multivariate data set, from which the matrices: X , X^t , Y , and b are defined, has the structure shown below:

$$\begin{array}{cccccc} X_1 & X_2 & X_3 & \dots & X_p & Y \\ X_{11} & X_{21} & X_{31} & \dots & X_{p1} & Y_1 \\ X_{12} & X_{22} & X_{32} & \dots & X_{p2} & Y_2 \\ X_{13} & X_{23} & X_{33} & \dots & X_{p3} & Y_3 \\ \dots & \dots & \dots & \dots & \dots & \dots \\ X_{1n} & X_{2n} & X_{3n} & \dots & X_{pn} & Y_n \end{array} \quad (6)$$

The values under variable X_1 (i.e. $X_{11}, X_{21}, X_{31}, \dots, X_{n1}$) can each be set equal to 1 to make sure the multivariate equation has a constant term. Then, from equation (6) we define the matrices X, X^t, Y , and b , and form the Matrix Products $X^t X$ and $X^t Y$ needed in equation (5). We obtain:

$$X = \begin{pmatrix} X_1 & X_2 & X_3 & \dots & X_p \\ 1 & X_{21} & X_{31} & \dots & X_{p1} \\ 1 & X_{22} & X_{32} & \dots & X_{p2} \\ 1 & X_{23} & X_{33} & \dots & X_{p3} \\ \dots & \dots & \dots & \dots & \dots \\ 1 & X_{2n} & X_{3n} & \dots & X_{pn} \end{pmatrix} \quad (7)$$

$$X^t = \begin{pmatrix} 1 & 1 & 1 & \dots & 1 \\ X_{21} & X_{22} & X_{23} & \dots & X_{2n} \\ X_{31} & X_{32} & X_{33} & \dots & X_{3n} \\ \dots & \dots & \dots & \dots & \dots \\ X_{p1} & X_{p2} & X_{p3} & \dots & X_{pn} \end{pmatrix} \quad (8)$$

where X^t = The Transposed of matrix X, has the rows and columns interchanged such that X is an $n \times p$ matrix, while X^t is a $p \times n$ matrix.

$$Y = \begin{bmatrix} Y_1 \\ Y_2 \\ Y_3 \\ \vdots \\ Y_n \end{bmatrix}; \text{ i.e. } Y \text{ is a column vector or } n \times 1 \text{ matrix} \quad (9)$$

$$b = \begin{bmatrix} b_1 \\ b_2 \\ b_3 \\ \vdots \\ b_p \end{bmatrix}; \text{ i.e. } b \text{ is a column vector or } p \times 1 \text{ matrix} \quad (10)$$

The matrix products appearing in equation (5) are all defined and have the dimensionalities:

$$\begin{aligned} X^t X & \text{ is } p \times p \text{ matrix} \\ X^t Y & \text{ is } p \times 1 \text{ matrix} \end{aligned} \quad (X^t X)b \text{ is } p \times 1 \text{ matrix} \quad (11)$$

$$\text{where } X^t Y = \begin{bmatrix} y_1 + y_2 + y_3 + \dots + y_n \\ y_1 x_{21} + y_2 x_{22} + y_3 x_{23} + \dots + y_n x_{2n} \\ y_1 x_{31} + y_2 x_{32} + y_3 x_{33} + \dots + y_n x_{3n} \\ \dots \\ y_1 x_{p1} + y_2 x_{p2} + y_3 x_{p3} + \dots + y_n x_{pn} \end{bmatrix} \quad (12)$$

and

$$\begin{aligned}
X'X &= \begin{bmatrix} 1 & 1 & 1 & \dots & 1 \\ X_{c1} & X_{c2} & X_{c3} & \dots & X_{cn} \\ X_{p1} & X_{p2} & X_{p3} & \dots & X_{pn} \\ \dots & \dots & \dots & \dots & \dots \\ X_{p1} & X_{p2} & X_{p3} & \dots & X_{pn} \end{bmatrix} \begin{bmatrix} 1 & X_{c1} & X_{c2} & \dots & X_{cn} \\ 1 & X_{c1} & X_{c2} & \dots & X_{cn} \\ 1 & X_{c1} & X_{c2} & \dots & X_{cn} \\ \dots & \dots & \dots & \dots & \dots \\ 1 & X_{c1} & X_{c2} & \dots & X_{cn} \end{bmatrix} \\
&= \begin{bmatrix} n & \sum_{t=1}^n X_{ct} & \sum_{t=1}^n X_{ct} & \dots & \sum_{t=1}^n X_{pn} \\ \sum_{t=1}^n X_{ct} & \sum_{t=1}^n X_{ct}^2 & \sum_{t=1}^n X_{ct} X_{ct} & \dots & \sum_{t=1}^n X_{ct} X_{pt} \\ \dots & \dots & \dots & \dots & \dots \\ \sum_{t=1}^n X_{pt} & \sum_{t=1}^n X_{pt} & \dots & \dots & \sum_{t=1}^n X_{pt}^2 \end{bmatrix} \quad (13)
\end{aligned}$$

The matrix solution to equation (5) is given by:

$$b = \begin{pmatrix} b_1 \\ b_2 \\ b_3 \\ \dots \\ b_p \end{pmatrix} = (X'X)^{-1} (X'Y) \quad (14)$$

where $(X'X)^{-1}$ is the Inverse of Matrix $X'X$ (see equation (13) above) which can be found using either the Gauss-Elimination method or the Adjoint Matrix method.

Note: If the $X'X$ matrix is Diagonal, i.e. it has non-zero elements only along the main diagonal, finding the Inverse matrix is trivial.

$$\text{For example, if } X'X = \begin{pmatrix} d_1 & 0 & 0 \\ 0 & d_2 & 0 \\ 0 & 0 & d_3 \end{pmatrix}, \quad (X'X)^{-1} = \begin{pmatrix} \frac{1}{d_1} & 0 & 0 \\ 0 & \frac{1}{d_2} & 0 \\ 0 & 0 & \frac{1}{d_3} \end{pmatrix}. \quad (15)$$

To complete the estimation of the multivariate model we need to first find the variances $V(b_1), V(b_2), V(b_3), \dots, V(b_p)$ from which then we can obtain: $\sigma(b_1) = \sqrt{V(b_1)}, \dots, \sigma(b_p) = \sqrt{V(b_p)}$. The

variance of the b vector ($b = \begin{pmatrix} b_1 \\ b_2 \\ \dots \\ b_p \end{pmatrix}$) is given by:

$$V(b) = (X^t X)^{-1} \hat{\sigma}^2 \tag{16}$$

$$\text{where } \hat{\sigma}^2 = \frac{Y^t Y - b^t X^t Y}{n - p} = \frac{Q^*}{n - p}, \tag{17}$$

and $Y^t Y = \sum_{i=1}^n y_i^2 = y_1^2 + y_2^2 + \dots + y_n^2$, $X^t Y$ was derived in equation (12) and b^t is the transposed of vector b , or $b^t = (b_1 \ b_2 \ \dots \ b_p)$.

After equation (17) is substituted into equation (16) and the multiplication of the matrix $(X^t X)^{-1}$ by $\hat{\sigma}^2$ takes place, $V(b)$ assumes the form:

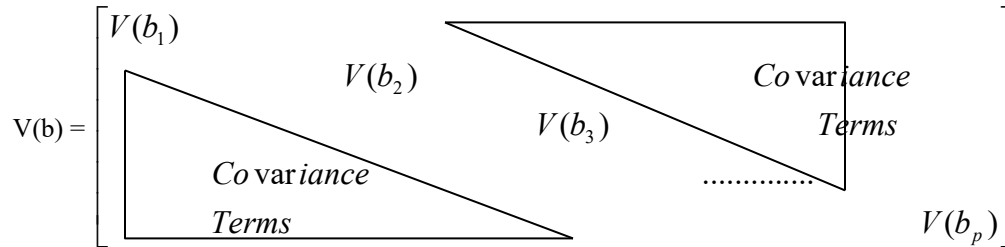

Therefore, the variances $V(b_1), V(b_2), \dots, V(b_p)$ are the values along the main diagonal of the $V(b)$ matrix, while the off-the-main-diagonal terms are Covariance terms.

Note: At this point, we have, for the given data set:

$$b_1, b_2, b_3, \dots, b_p \text{ and } \sigma(b_1), \sigma(b_2), \sigma(b_3), \dots, \sigma(b_p).$$

MODEL TESTING & EXAMPLE

Now that our model of interest has been estimated, we need to test for the significance of the terms found in the estimated model. This is very important because the results of this testing will determine the final equation which will be retained and used for Forecasting purposes.

Testing THE MULTIVARIATE MODEL $\hat{y} = b_1 X_1 (= 1) + b_2 X_2 + \dots + b_p X_p$

Testing of this model consists of the following 3 steps:

A) To test for the significance of each factor separately

The values of $b_1, b_2, b_3, \dots, b_p$ are obtained from equation (14) and the values of

$\sigma(b_1), \sigma(b_2), \sigma(b_3), \dots, \sigma(b_p)$ from equations (16) and (17). Then, we test for the significance of each factor separately by either:

$$1) \text{ Testing the hypotheses: } H_0 : \beta_i = 0 \text{ vs. } H_1 : \beta_i \neq 0 \text{ by calculating } Z_i^* = \frac{b_i}{\sigma(b)_i} \text{ or } t_i^* = \frac{b_i}{\sigma(b)_i},$$

for $i = 1, 2, 3, \dots, p$. Then, $H_0 : \beta_i = 0$ is rejected if $Z_i^* > Z_{\alpha/2}$ (or if $Z_i^* < -Z_{\alpha/2}$), when $n \geq 30$ or if $t_i^* > t_{n-p(\alpha/2)}$ (or if $t_i^* < -t_{n-p(\alpha/2)}$), if $n < 30$

or 2) By constructing the confidence intervals

$$P[b_i - Z_{\alpha/2} \sigma(b)_i \leq \beta_i \leq b_i + Z_{\alpha/2} \sigma(b)_i] = 1 - \alpha, \text{ if } n \geq 30$$

or

$P [b_i - t_{n-p}(\alpha/2) \sigma(b_i) \leq \beta_i \leq b_i + t_{n-p}(\alpha/2) \sigma(b_i)] = 1 - \alpha$, if $n < 30$.

If the value $\beta_i = 0$ is outside of these Confidence intervals, $H_0 : \beta_i = 0$ is rejected.

B) To test for the Significance of the entire Regression (including the constant)

The hypotheses being tested are:

$$H_0 : \beta_1 = \beta_2 = \beta_3 = \dots = \beta_p = 0 \text{ vs. } H_1 : \text{The } \beta_i \text{ are not all equal to } 0$$

or H_0 : The entire regression (including the constant) is not significant

vs.

H_1 : The entire regression (including the constant) is significant.

It is carried out by calculating:

$$F_{Total}^* = \frac{RSS / DOF}{ESS / DOF} = \frac{b^t X^t Y / p}{(Y^t Y - b^t X^t Y) / n - p} \text{ and comparing to } F_{n-p}^p(\alpha).$$

If $F_{Total}^* > F_{n-p}^p(\alpha)$, H_0 is rejected and we conclude that the entire regression (including the constant) is significant (to the calculation of the Y value).

C) To test for the Significance of the entire Regression (excluding the constant)

The hypotheses being tested are:

$$H_0 : \beta_2 = \beta_3 = \dots = \beta_p = 0 \text{ vs. } H_1 : \beta_2, \beta_3, \dots, \beta_p \text{ are not all equal to } 0$$

or H_0 : The entire regression (excluding the constant) is not significant

vs.

H_1 : The entire regression (excluding the constant) is significant.

It is carried out by calculating:

$$F_{Total-\beta_1}^* = \frac{(RSS - SS_a) / p - 1}{ESS / n - p} = \frac{(b^t X^t Y - SS_a) / p - 1}{(Y^t Y - b^t X^t Y) / n - p}$$

and comparing it to $F_{n-p}^{p-1}(\alpha)$. If $F_{Total-\beta_1}^* > F_{n-p}^{p-1}(\alpha)$, H_0 is rejected and we conclude that the entire regression (excluding the constant) is significant.

D) Determination of the Final equation

Any variable X_i , for which the hypothesis: $H_0 : \beta_i = 0$ (vs. $H_1 : \beta_i \neq 0$) is not rejected, is to be dropped from the regression equation. The remaining terms are used to form the “Final Equation” which is then retained and used for Prediction/Forecasting purposes.

SUMMARY OF MULTIVARIATE PROCEDURE

Procedure for solving multivariate/bivariate problems

A) Model Estimation

Given a Multivariate (or bivariate) data Set:

- 1) Identify the matrices: Y, X, b, Z which form the matrix equation $Y = Xb + Z$
- 2) Calculate $X^t X$ and $X^t Y$
- 3) Calculate The Inverse of Matrix $(X^t Y) = (X^t X)^{-1}$

- a. If X^tX is a diagonal Matrix, $(X^tX)^{-1}$ is easy to find
- b. If X^tX is not Diagonal, Finding $(X^tX)^{-1}$ is more difficult
 - i. Use the Gauss Elimination Method
 - ii. Use the Adjoint Matrix Method

$$4) \text{ Calculate: } b = \begin{pmatrix} b_1 \\ b_2 \\ \dots \\ b_p \end{pmatrix} = (X^tX)^{-1} X^tY$$

- 5) Calculate: Y^tY , b^tX^tY , $Q^* = Y^tY - b^tX^tY$, $SSa = (\sum Y_i)^2/n$
- 6) Calculate: $\sigma^2 = Q^*/n-p$
- 7) Calculate: $V(b) = (X^tX)^{-1} \sigma^2$ ← The Variances $V(b_1), V(b_2), \dots, V(b_p)$ are along the Main Diagonal

Note1: The other terms of the $V(b)$ matrix are covariances

Note2: At this point we have: b_1, b_2, \dots, b_p and : $\sigma(b_1), \sigma(b_2), \dots, \sigma(b_p)$

Also available are all the sums of squares

B) Model Testing

a) To Test for the Significance of Each Factor Separately

- 1) From the knowledge of b_i and $\sigma(b_i)$
Use Either Z (if $n \geq 30$) or t_{n-p} (if $n < 30$) to test :
 $H_0: \beta_i = 0$ vs. $H_1: \beta_i \neq 0$
 - 2) From the knowledge of b_i and $\sigma(b_i)$
Use either Z or t_{n-p} to construct confidence intervals
 $P[b_i - Z_{\alpha/2} \sigma(b_i) \leq \beta_i \leq b_i + Z_{\alpha/2} \sigma(b_i)] = 1 - \alpha$
- or
- $$P[b_i - t_{n-p}(\alpha/2) \sigma(b_i) \leq \beta_i \leq b_i + t_{n-p}(\alpha/2) \sigma(b_i)] = 1 - \alpha$$

b) To Test for the Significance of the Entire Equation (Including the Constant)

- 1) Construct ANOVA with SSa
- 2) Test the Hypothesis : $H_0: \beta_1 = \beta_2 = \beta_3 = \dots = \beta_p = 0$ vs. $H_1: \text{The } \beta_i \text{ are not all } = 0$
 - I. Calculate $F_1^* = [(b^t X^t Y)/p] / [Q^*/n-p]$
 - II. Compare F_1^* to : $F_{n-p}^p(\alpha)$
 - III. Reject H_0 if : $F_1^* > F_{n-p}^p(\alpha)$

c) To Test For the Significance of the Entire Equation (excluding the Constant)

- a. Construct ANOVA without SSa
- b. Test the hypothesis: $H_0: \beta_2 = \beta_3 = \dots = \beta_p = 0$ vs. $H_1: \text{The } \beta_i \text{ are not All } = 0$
 - i. Calculate $F_2^* = (b^t X^t Y - SSa) / p - 1$
 $Q^* / n - p$
 - ii. Compare F_2^* to : $F_{n-p}^{p-1}(\alpha)$
 - iii. *Reject H_0 If : $F_2^* > F_{n-p}^{p-1}(\alpha)$*

DETERMINE THE FINAL EQUATION

Any Variable, X_i , for which the Hypothesis: $H_0: \beta_i = 0$ vs. $H_1: \beta_i \neq 0$ is not rejected, is to be dropped from the regression equation. The remaining terms are used to form the “Final Equation” which is then retained and used for Prediction/Forecasting purposes.

CONCLUSIONS

1. Regression Analysis, whether Linear, Non-Linear, or Multivariate, is extremely important as a Forecasting Technique.
2. Linear Regression is relatively easy to perform using purely algebraic methods.
3. But, Linear Regression can also be considered as a special case of the more general Multivariate Regression Model, which can be analyzed efficiently by using matrix methods.
4. A step-by-step procedure on how to solve the multivariate regression problem is included in this paper.
5. The Application of the Method (which consists of: Model Estimation, Model Testing, and the derivation of the FINAL Regression equation which is retained and used for forecasting purposes) requires an elementary knowledge of Matrix Algebra, including the calculation of the Inverse Matrix.
6. Statistical tools, such as the MINITAB, can also be used to solve the Multivariate problem by computer, and then compare the hand and MINITAB results.
7. Using MINITAB to also solve the sample problem, produces solutions which are identical to the hand solutions.
8. The MINITAB output not only estimates the model, but also generates “p-values” for all the important model parameters, which allows the testing of their significance.
9. The p-value, called the “Observed level of significance,” in contrast to the a-priori α value, has the following relationship to α :
 - a) If $p > \alpha$, do not Reject H_0 .
 - b) If $p < \alpha$, Reject H_0 .
10. The MINITAB output also provides values for R^2 (coefficient for Multiple Determination) and R^2 adjusted which tells us “how well” the model fits the given data.

REFERENCES

- Berenson, Marc, L.; Levine, David, M.; Krehbiel, Timothy, C.; “Basic Business”
- Black, Ken; Business Statistics, Wiley 2004.
- Canavos, George, C.; Applied Probability and Statistical Methods; Little, Brown; 1984.
- Childress, Robert, L.; Gorsky, Robin, D.; Witt, Richard, M.; Mathematics for Managerial Decisions, Prentice Hall, 1989.
- Carlson, William, L.; Thorne, Betty; “Applied Statistical Methods”, Prentice Hall, 1997.
- Childress, Robert, L.; Gorsky, Robin, D.; Witt, Richard, M.; Mathematics for Managerial Decisions.
- Chou, Ya-lun; “Statistical Analysis for Business and Economics”; Elsevier, 1992
- Draper, Norman; Smith, Harry; Applied Regression Analysis John Wiley & Sons, 1966
- Johnson, J. Econometric Methods, McGraw-Hill, 1963.
- Pindyck, Robert S; Rubinfeld, Daniel L.; Econometric Models and Economic Forecasts, 2nd Edition McGraw-Hill, 1981
- Vasilopoulos, A. “Business Statistics – A Logical Approach. Theory, Models, Procedures, and Applications Including Computer (MINITAB) Solutions”, Boston, MA; Pearson Custom Publishing, 2007.

Vasilopoulos, A. & Lu, F. Victor. "Quantitative Methods for Business with Computer Applications", Boston, MA; Pearson Custom Publishing, 2006.

Vasilopoulos, A. "Regression Analysis Revisited", Review of Business, St. John's University, Jamaica, NY; 2005.

THE EFFECTIVENESS OF BOARD GAME LEARNING AS AN EDUCATIONAL TOOL IN EMPLOYEE DEVELOPMENT.

Marius Wait and Mariette Frazer
University of Johannesburg, South Africa

ABSTRACT

Board games as an educational tool in the development of employees are an underutilised instrument. It is one of many interventions used in employee development, but its effectiveness has not been widely studied by academia. Company executives often have preconceived ideas about this form of education but need to consider including board game learning (BGL) into employee development as it creates a big business picture in a practical, interactive way.

This qualitative study explored the opinions of employees after a board game was introduced into their curriculum. Two group interviews were conducted and the content of this transcribed data was subjected to deductive content analysis. The results indicated definite success as the employees were both entertained and educated. This educational tool has proven its success in employee development, a serious consideration for company executives.

Keywords: board game learning, employee development, game based learning.

INTRODUCTION

The true value and impact of board games designed for employee development is unrecognised. This is partly related to a pervasive lack of knowledge about how people learn. Many business executives have the view that games of any kind are inappropriate for employee learning, simply because they do not understand the power of play and entertainment in education. Game playing has a positive impact on brain activity, stimulating retention and engaging players towards more effective cognition than instruction that is more traditional. Because games are goal orientated, they often increase motivation and provide trial and error opportunities to help learners develop problem solving and critical thinking skills. The positive attributes of games and their learning effectiveness suggest that they should be included more often in efforts to teach curriculum content (Sardone and Devlin-Scherer 2016: 215).

Board game learning (BGL) falls under the umbrella of game based learning (GBL), and is underpinned by the basic principles of social learning theory (SLT), which states that people learn by observing others. The concept of SLT is that social learning can be applied to almost any social programme that aims to influence behaviour, particularly those behaviours that are complex or involve interaction with other people (Smith and Berge 2009; Kapp 2017; Herro and Clark 2016).

The true value and impact of board games designed for employee development is mostly unrecognised, and this field of research has been neglected by academia. This paper presents the opinions of employee board game players with the aim of exploring the effect of board games as an educational tool on employee development in the retail industry. The objectives of the study were (1) to incorporate a board game into an employee development curriculum, (2) to explore the participants' experience of playing this board game, and (3) to discuss the participants' perceptions of the usefulness of this board game activity.

This introduction provides a general background to the research topic and is followed by a literature review related to the employees' training techniques with special reference to board game learning (BGL). The research

methodology is explained using two group interviews with a qualitative deductive content analysis. The paper continues with the presentation of results and a discussion of them, and ends with managerial implications and a conclusion.

As this study was conducted in a corporate environment with particular reference to employee development, it includes concepts of corporate training, employee training and job training within the concept of employee development.

LITERATURE REVIEW

Employee Development

Modern international research shows that the knowledge and skills of university graduates are insufficient for them to work successfully within a company, regardless of when they graduate. The changes, growth and complexity of the workplace require that graduates improve their qualifications at the workplace. This investment in the training of staff contributes to achieving leading market positions, thus ensuring maximum self-fulfilment and payoff in terms of career development (Masalimova *et al* 2016). Kum *et al* (2014: 72) agree and state that employees need to continuously learn new skills and that the main purpose of employee development is to give employees the knowledge and skills they need to perform effectively in their field of expertise.

Kum *et al* (2014: 74) opine that employee development is something that conjures images of intrusive all-day training sessions. This image is exactly the opposite of how employee development should be implemented and experienced by the employees. Employee development can manifest itself in many forms of training, evaluation, educational programmes and feedback.

Below is a table with brief descriptions of the various educational tools used for employee development, together with their respective advantages and disadvantages.

Table 1: Educational tools used in employee development

Method	Brief description	Advantage	Disadvantage
Modular learning	Independent and complete topical fragments of training directed toward achieving specific objectives or determining and developing the skills required for specific purposes or results.	Active participation of the trainees; possibility of changing the sequence of modules depending on the trainees' requirements.	Modules depend on each other and may have a mandatory sequence.
Case study	Involves an up-close, in-depth examination of a subject and its related contextual conditions; is conducted through practical activity, discussions, and group or individual solutions, reinforcing knowledge and skills for further use in practice.	High level of participation; control and assessment of knowledge acquired; urgency of issues considered; linking learning to practice.	Time can be wasted when discussion is not organised properly; the result depends on necessary knowledge and experience and on the direction and control of a trainee; training requirements for trainers should be met.
Training session	Ensures intensive and interactive instruction that encourages trainees to communicate and share professional experience and	Opportunity to develop and reinforce the necessary skills and to change trainees' attitudes to their own experience and	Difficulties in analysing one's own behaviour; post-training classes are needed to reinforce and strengthen training effects.

	skills of practical value, saving time and resources.	approaches.	
Business game	Training based on themes and situations that simulate real professional activities and demonstrate the eventual solution made and actions of participants.	Connection with professional activity; prediction of the eventual results; comprehensive coverage; training through simulation of real situations ; helps to reduce operating cycles; opportunity to generate and enrich knowledge through creative and emotional interaction with partners.	Requires specific rules and introductory information which determines the sequence and content of the game; printing of the most frequent models of real situations required; needs constant updating.
Metaphoric game	Creative immersion in situations involving changed stereotypes and directed toward generation of new activities and shift of attitude; accompanied by introduction of a 'support team' with the aim of studying competitors; development of optimal strategies to expose effective models of behaviour that can be transferred into specific situations.	Develops the trainee's creativity; attractive for application with all categories of trainee; participants are free to address the specified situations and offer solutions.	Requires metaphorical proficiency of participants, i.e. knowledge of legends, parables, and so forth.
Role play	Active training in interpersonal interaction through typical simulated work situations involving the roles of various leaders and subordinates; considered as preparation for management jobs.	Provides instruction in habits of interpersonal communication; makes it possible to understand the motives behind the behaviour of particular employees; makes it possible to see errors.	Requires combination of various types of training; requires appropriate qualification of the trainer (instructor).
Brainstorming	Involves collection of various ideas and recording them in written form; effectiveness depends on participation level of leaders who act as hosts, their familiarity with relevant purposes and objectives, and whether they can manage the process of generating new ideas.	Does not require preparation; does not require development of ideas; can help overcome psychological stress or barriers; contributes to constructive criticism.	Is not suitable for solving complex problems; does not have criteria to evaluate the strength of solutions; difficulty in determining the best ideas; difficulties in management.
Project	Predicts the combination of the individual's independent	Makes it possible to form one's point of view and to	Requires scientific management; requires high

	work and collaboration with groups, in a team; involves work with diverse information sources, uses and research methods, which make it possible to expose alternative points of view.	generalise from the material; contributes to forming a corporate and research culture.	levels of multi-professional competencies for developing projects in the team.
Behavioural simulation	Involves training in concrete skills and attitudes for performing professional activities via simulated and proposed behavioural models; requires trainees' confidence and willingness to follow the model, which can be ensured by the transparency of the desired result.	Contributes to developing interpersonal communication skills; takes into account a person's individual features; is flexible in respect of time.	Requires confidence and willingness of trainees to follow the model of the behaviour proposed; requires transparency of desired results; dependence of this method on the level of a trainee's motivation.
Mentoring	Professional training of young trainees and their adaptation to a company, which implies sharing experiences with highly qualified trainers and being informed about peculiarities of work in the company as well as corporate values; training is carried out in the workplace during working hours, which helps to reduce the adaptation and implementation period.	On-the-job training; contributes to adaptation of young specialists; ensures success in developing corporate culture in the personnel; ensures professional growth of colleagues.	Requires personal qualities and competencies, including experience in training, that meet company requirements and help the trainer to conduct the activity.
Story telling	Telling stories on the lives of peers and colleagues to present information about the traditions, philosophy and corporate culture of the company; includes study of necessary local regulations.	Facilitates new employees' adaptation and promotes their loyalty to the company.	Requires a high level of qualification and knowledge of the history, current situation and prospects of the organization; requires skills developed within the short period allocated to orientate colleagues.
Training (learning) through participation	Corporate management seeks to resolve emerging organizational challenges through employee participation and involvement; develops the structure and dynamics of change without removing employees from their jobs; combines regular situation analysis, setting of new goals, and thinking through of steps to achieve them.	Development of decision making skills; development planning, plan fulfilment and goal setting skills; opportunity to solve business problems; close connection with professional activity.	Requires peers and colleagues (assistants) capable of solving complex real-life problems to overcome the gaps, imaginary or real, in the company.
Training in	Workgroups, or teams,	Different trainee groups	Requires that the group has

work teams	consisting of specialists of different levels are formed to solve specific problems in certain time intervals, developing the algorithm of tasks set, and determining the length of time needed to solve them; team proposals are considered by the company management and can be either accepted or rejected.	enrolled regardless of their level of qualification; development of self-determination and independence of employees, including decision-making skills and increased motivation.	been previously informed and trained on methodology and analytical methods of problem solving.
In basket	Training to identify and train management talent and skills, offered to senior executives and managers, and based on imitation of typical work situations whereby the trainee is given a list of items (a number of mails, telephone calls, documents and memos, planned and unplanned meetings, etc) which must be addressed within a certain period; he/she is asked to prioritise the items and explain his/her reasons to the panel, concerning what is important and what is urgent; a number of problems are kept in the 'in basket' to be looked at and solved and transferred to the 'out basket'.	Develops the capability to analyse and select the more important factors; high level of motivation; involvement in the process of problem solving; unbiased assessment of participants.	Requires preliminary training on how to work with documents and objective self -assessment of one's own abilities to analyse, understand the system, and select the most significant factors in considering problems according to their urgency, and determining ways and methods to solve them successfully.
Rotation	Independent and autonomous training through rotational programmes (in different parts of a company) or specific, structured training programmes, which offer the trainee/employee new skills and perspectives on various areas of organization and new social contacts that contribute to positive motivation and counteract boredom and monotony; a polyvalent qualification.	Contributes to developing new poly-professional competencies; provides motivation; counteracts the stress caused by monotonous work; encourages the best application of knowledge, abilities and interests; opens new opportunities, expands contacts, and teaches necessary skills, which can help the employee to advance within a company.	Requires the creation of conditions for free systematic movement of employees from one job to another within the structure of the organization, which may prevent them from using previously acquired skills; possible discrepancies between desired and proposed jobs or positions in the organization.
Secondment	Similar to rotation, but difference is that a 'job swap' may take place not only in another division of	Develops poly-professional competencies; contributes to the trainee's personality development;	Requires creation of conditions for free systematic movement of employees from one job to

	the same company, but also in an external organization and in a different sphere, before returning to a previous position.	improves interpersonal communication skills.	another; may prevent them from using previously acquired skills; risk of possible discrepancies between desired and proposed jobs or positions in the organization.
Buddying	A technique to help already capable staff to learn how to apply their skills more quickly and to reduce floundering at work when a new hire starts; entails equal partnership of the trainee and a guide, in contrast to tutoring; supposed to ensure positive and constructive criticism when undertaking new responsibilities or developing new skills through accomplishing a task and new current responsibilities.	Opportunity to have a detached observer's point of view and see disadvantages; equal rights to the participants; opportunity for the trainee to outline their advancement within the company.	Requires that feedback and information are objective; constant control by, or on behalf of, the HR department.
Shadowing	Opportunity for the trainee to become immersed for a certain period in the role of an executive and gain a better idea of the job, including information on its special features and requisite knowledge; can be effective in re-training.	Contributes to rapid adaptation of a trainee; allows immersion in the real professional activity.	Requires desire and willingness of senior executives and managers to share their experience; requires necessary conditions to be created for trainees to objectively evaluate and assess their abilities.
On-line training		Cost effective; updated with ease; offers various forms of questions and quizzes; interactive as trainees can share ideas on forums.	Retention does not last long; this type of training can be a problem for employees who are not internet savvy.

Source: Adapted from Masalimova *et al* (2016), Treher (2011), Kum *et al* (2014), Dorjkhoo (2013)

This table is by no means exhaustive. Board games are also an educational tool for employees, but this has been purposely omitted from the table as it will be discussed in depth next.

BOARD GAMES AS AN EDUCATIONAL TOOL

Board games

Games and simulations have been used since the 1600s to allow learners to apply their knowledge, skills and strategies and learn from the consequences in a safe environment (Gredler, 2004: 571). The aim of these interventions is to improve the learners' decision making skills and the effectiveness of their decisions (Poonnawat *et al* 2015: 439). In addition, games motivate learners to get involved in learning activities, as games offer a safe

learning environment and draw learners together in a comfortable competitive situation (Kirkland *et al*, 2008: 2). Observing peer learning and surrounding oneself with other people when learning adds another level of meaning and context to the learning (Fujimoto *et al* 2015: 204). Business simulations are used as an educational platform to simulate each business activity in the business process that requires someone to manage the activity and make a decision (Poonawat *et al* 2015: 440). Simulations are designed to provide a realistic opportunity to experience potential situations and decisions that learners may face in the workplace (Weidman & Coombs 2016: 15).

Board games, as an educational tool, lend themselves to many research predicaments. There seems to be uncertainty in the literature on the correct terminology to use for this form of education. Research on this topic has mainly focused on a junior level curriculum (Sardone & Devlin-Scherer 2016; Hainey *et al* 2016; Treher 2011). The broader term ‘game based learning’ (GBL) can also be a misnomer, as this can cover board games, card games, mobile games and video games, which can all be used in education (Kapp 2017; Herro & Clark 2016). Some researchers tend to speak only of ‘game learning’, which may not cover board games (Sardone & Devlin-Scherer 2016), whilst others use ‘simulation games’, which refers mainly to video games (Raybourn 2014).

The researchers of this study found these terms misleading and therefore preferred the term ‘board game learning’ (BGL), as this is more precise. However, the typical board game used for family entertainment, such as Monopoly and Risk, should also not be confused with tailor-made industry specific board games used as an education tool with specific curriculum outcomes. Sardone and Devlin-Scherer (2016: 215) are of the opinion that board games are making a comeback and state that the sales of board games are rising for various companies; for example, in 2013, Hasbro, which sells 60 different board games, reported an increase in sales of over 20% (Hasbro 2013). Cafés, taverns and bookstores provide space to welcome gamers. Games 4 Brains (www.games4brains.co.za) is another board game company that promotes kids and adult entertainment via board games, while Business Today (www.businessdaysimulations.com) specialises in customised employee development interventions with over 170 board games. Celemi is another company that uses board games as an educational tool and goes as far as calling this form of training ‘experiential learning’. Celemi is of the opinion that when employees need to understand new concepts, change behaviour and improve performance, they should learn by doing and not by manuals and slide shows (<http://celemi.com>).

Board games as learning tools provide hands-on learning and knowledge development for learners in a non-threatening, playful environment. The board in the game provides a visual metaphor to help connect the information and facilitates the flow of game process, discussions and problem solving (Treher 2011: 3). Treher continues by stating that not only do well-designed board games create an engaging atmosphere, but BGL also provides a competitive environment in which learners can focus on content and reinforce and apply learning. The vehicles of learning in BGL are the game elements, discussion with team members, problem solving and situational analysis. Effective BGL organises information in a conceptual framework to make it concrete. It provides workplace similarities and descriptions to link new information. When a board game is played in teams, the team members learn together, and no one feels singled out for not knowing an answer. Interaction in teams can also help participants to verify their understanding and learning. BGL can also transform abstract business concepts into concrete ones, and it is also an excellent tool to accommodate different learning styles. BGL requires critical thinking, and team-based board game participants work face to face to answer questions or solve problems. The paper money that is often used in these board games is an example of how understanding works. All the players have used money to purchase goods that are needed, yet that experience of using money does not necessarily translate into understanding how to grow, protect, or use money wisely (Treher 2011: 2–4).

This study focuses on a bespoke board game designed to upskill employees in the retail industry. A brief description of this specific game follows in the methodology section.

Social Learning Theory

BGL as an educational tool is underpinned by social learning theory (SLT). The seminal SLT research was done in 1977 by Albert Bandura, who stated that SLT is based on the idea that we learn from our interactions with others in a social context (Smith & Berge 2009). Thus employees can also learn new behaviours by observing others. According to SLT, people learn by observing what others do, consider the apparent consequences experienced by

those people, rehearse what might happen in their own lives if they followed the other people's behaviour, take action by trying the behaviours themselves, compare their experiences with what happened to the other people, and confirm their belief in the new behaviour. SLT is especially useful when a particular behaviour is difficult to describe but can be explained through demonstration and modelling (Smith & Berge 2009; Bandura 1977).

RESEARCH METHODOLOGY AND DESIGN

Description of a business board game

A brief description of the board game introduced into the curriculum of retail employees follows next.

The target population for this study's BGL was retail store employees at various management and experience levels – individuals with prior knowledge of the retail industry. This business simulation game is designed as a board game and can be played with 4 to 6 teams of 3 to 4 members each. Each team uses workbooks, a simulation board with various markers that represent the money (cash and debtors), non-current assets, liabilities (loans and creditors), staff and stock in the business.

The board game starts with each team having a running retail concern with six retail outlets already in operation. All the teams start off at the same financial and market share position. The teams decide on a name for their enterprise and allocate various business roles to the team members in terms of marketing, operations, finance, human resources and general management. The business and decision making processes of the game that need to be adhered to in each step are explained to the teams by a qualified facilitator. This facilitator also acts as the supplier of market research, stock and banking services. Teams have to negotiate with the facilitator in the same manner as in a real life situation. Parameters are set for the facilitator to allow for fair negotiations.

During the first cycle – round one – the teams are required to make market related decisions, which are then entered into a computer model that divides the available market share between the teams. This is calculated on the basis of comparing the teams' product sales, stock levels, customer service levels, and promotion spend.

In round two, still of cycle one, the teams must clear remaining stock and pay off their expenses. Once this is achieved, the teams must compile financial statements and produce a performance analysis, calculating the key performance indicators (KPIs) of their retail enterprise. The results are compared on a group basis. The facilitator guides the groups in understanding each of the KPIs and discovering which decisions resulted in good performance and which decisions had a negative impact.

In round three the facilitator guides the learning of real business finance in the game by taking published financials of a retail organization and assisting the students in interpreting the key numbers on these statements. The second cycle starts and the teams follow the same business process as in the first cycle. This allows the teams to adjust their decision making based on what was learned during the first cycle. The financial results of the teams are again compared. The facilitator guides the teams in reflecting on and discovering the impact of their decisions. The business simulation ends and the teams' performances are ranked to determine the final results of the group.

In order to explore the effect of BGL in employee education, the opinions of employee learners who participated in a simulation board game were appraised. Petzer *et al* (2011: 32) state that exploratory research is usually linked to qualitative research. This article's qualitative research design made use of two group interviews after the board game intervention, which were analysed by using content analysis. Content analysis is described as a method to classify written or oral materials into identified categories of similar meaning. Elo *et al* (2014) state that qualitative content analysis is commonly used for analysing qualitative data and is one of several qualitative methods available for analysing data and interpreting its meaning. As a research method, qualitative content analysis represents a systematic and objective means of describing and quantifying phenomena. In qualitative content analysis the abstraction process is the stage during which concepts are created. From a validity point of view, it is

important to report how the results were created, and the reader should be able to clearly follow the analysis and resulting conclusion.

Elo *et al* (2014) continue and state that qualitative content analysis can be used in either an inductive or a deductive way. Both approaches involve three phases, namely preparation, organization, and reporting of results. Cho and Lee (2014) state that the major difference between the two approaches is in how initial codes or categories are developed. An inductive approach is used when prior knowledge regarding the phenomenon under research is limited and themes are directly drawn from the data, whereas a deductive approach starts with preconceived codes or categories derived from theory, research or literature. The deductive approach is appropriate when the objective of the study is to test an existing theory or re-test data in a new context. This study made use of deductive content analysis as the categories were not formed from the data but prior to the research, to be aligned with the aim and objectives of this study; and the method described by Elo *et al* (2014:3) was used.

Preparation phase: During this phase the researcher must consider the data collection method, the sampling strategy, and the unit of analysis to be selected. For the purpose of this study, the researcher wanted to explore opinions about board games as an educational tool. The group interview participants were randomly selected from a list of employees that had successfully completed the board game. There were 10 participants in each group interview. The units of analysis were the recorded and transcribed interviews.

Organizational phase. During this phase the researcher must consider categorization and abstraction, interpretation and representativeness. This phase involves the categorization matrix development whereby the data is reviewed for content and coded for correspondence to categories. For the purpose of this study, the researchers acted as the interviewers and led the group interviews according to a predetermined topic list related to the aim and objectives of the study. For this study, the following categories were created for the group interviews.

- a) What is your confidence level now about business decision making?
- b) What specific expectations were met?
- c) What in your opinion were the simulation game benefits?
- d) Do you think that the simulation game will make you more confident in your work environment?

Reporting phase. During this phase the researcher must consider reporting results and reporting the analysis process. The data from the transcribed meetings was then analysed using the qualitative deductive content analysis and the predetermined category method.

RESULTS AND DISCUSSION

Overall the participants' experience of the board game was positive. The referencing system for the two group interviews with direct quotations will be: Group (1) and Group (2).

The respondents agreed that their business decision making confidence had increased. The majority had limited or no confidence but after the board game the participants felt there was an increase in their confidence levels: Group (1) "Much better"; Group (2) "Much more than before the game, it taught me a lot". This finding ties in with the research done by Sardone and Devlin-Scherer (2016: 221) whereby board games promote creativity, concentration and confidence; and this correlates with testimony on Business Today's website stating that the board game simulation had added tremendous value in terms of the development of business acumen, operational skills and strategic thinking skills (<http://www.businesstodaysimulations.com/references-2/>).

The respondents in this study expected that the board game would teach them more about the retail business environment. Overall the respondents got more from the board game than expected: Group (1) "Doing it practically gave me the bigger picture"; Group (2) "I now understand finance and how to run a business better". This finding confirms the research done by Treher (2011: 6), who states that board games are able to demonstrate a greater understanding of the business. This finding is also corroborated by a Celemi client's testimony: "I can now see the bigger picture" (<http://celemi.com/casestudy/honeywell-business-skills-for-new-leaders/>).

All the respondents felt that including the board game in their curriculum benefited them greatly: Group (1) “I now see that all the stakeholders are important”; Group (2) “To me it was understanding the business processes”. This finding ties in with the research done by Sardone and Devlin-Scherer (2016: 215), which states that games should be included more often to teach curriculum content because of their positive attributes and learning effectiveness. All the respondents unanimously agreed that the simulation board game would make them more confident in the workplace: Group (1) “Yes”; Group (2) “Yes”.

In summary, the finding from the participants’ feedback was overwhelmingly positive. Doing part of a curriculum practically or by experiencing the workplace in the form of a board game is an entertaining and fun method of teaching employees. The BGL method increased the overall confidence level of employees in this study, as well as their confidence in making business decisions. The employees also felt that their expectations from playing a board game were exceeded, as they could see the bigger picture of the business they were employed in and not only that of their specific discipline, as is the case with subject specific lectures.

MANAGERIAL IMPLICATIONS

Managers and company executives often see employee development in terms of ‘days off work’. This may also be seen as a financial grudge. Evidence of the effectiveness of board games in the development of employees makes their inclusion in employee development very necessary. This educational tool provides a practical, bigger picture of the business and not only specific subject knowledge. With the time the employees spend away from the office, much can be learned that is of value to their work. Managers should plan ahead and when a skill shortage is identified in terms of a curriculum, board game learning should be considered. Managers must also be able to accommodate all kinds of employees in their arsenal and board game learning is an effective way to bring people of various academic backgrounds together. This is a fun a social learning environment and may eliminate any feelings of inadequacies from employees. Managers must allow employees to see the company in a holistic view.

LIMITATIONS

This study was conducted in only one industry sector, namely retail, and took place in Johannesburg, South Africa.

CONCLUSION

Many articles are written on GBL and simulation games and their impact on learners. However, research on using BGL for employee development is scarce. This article provides exploratory insight into the effectiveness of this form of educational tool. Evidence from the results indicates that the introduction of a board game in the curriculum of the participating retail employees was a resounding success. Companies may want to investigate further this form of entertainment in education.

REFERENCES

- Aldridge, R., Callahan, R.A., Chen, Y. and Wade, S.R. 2015. Income tax preparation assistance service learning program: A multidimensional assessment. *Journal of Education for Business*, 90(6), pp. 287–295.
- Bandura, A. 1977. *Social learning theory*. Englewood Cliffs, NJ: Prentice-Hall.
- Baptista, R., Coelho, A. and de Carvalho, C.V. 2015. Relationship between game categories and skills development: Contributions for serious game design. *9th European Conference on Games Based Learning: ECGBL2015*, p. 34. Reading, Berkshire: Academic Conferences and Publishing Limited.
- Celemi. No date. Serious games for learning and change. <http://celemi.com>
- Cho, J.Y. and Lee, E.H. 2014. Reducing confusion about grounded theory and qualitative content analysis: Similarities and differences. *The Qualitative Report*, 19(32), pp. 1–20. <http://nsuworks.nova.edu/tqr/vol19/iss32/2>
- Dorjkhuu, O. 2013. *Employee training methods for developing economy*. National Academy of Governance of Mongolia. http://www.tokyofoundation.org/syllff/wp-content/uploads/2013/04/report_web.pdf
- Elo, S., Kääriäinen, M., Känste, O., Polkki, T., Utriäinen, K. and Kyngäs, H. 2014. Qualitative content analysis: A focus on trustworthiness. *Sage Open*, Jan.–March, pp. 1–10.
- Fujimoto, T., Fukuyama, Y. and Azami, T. 2015. Game-based learning for youth career education with the card game ‘JobStar’. *9th European Conference on Games Based Learning: ECGBL2015*, p. 203. Reading, Berkshire: Academic Conferences and Publishing Limited.
- Hainey, T., Connolly, T.M., Gray, G., Earp, J., Ott, M., Lim, T., Ninaus, M., Ribeiro, C. and Pereira, J., 2016. An update to the systematic literature review of empirical evidence of the impacts and outcomes of computer games and serious games. *Computers & Education*, 94, pp.178-192.
- Gredler, M.E. 2004. Games and simulations and their relationships to learning. In D.H. Jonassen (Ed.), *Handbook of research on educational communications and technology*, 2nd edition, pp. 571-581. Mahwah, NJ: Lawrence Erlbaum.
- Hasbro. 2013. *Hasbro reports growth for the first quarter 2013*. <http://investor.hasbro.com/releasedetail.cfm?releaseid=758021>
- Herro, D. and Clark, R. 2016. An academic home for play: Games as unifying influences in higher education. *On the Horizon*, 24(1), pp. 17–28.
- Kapp, K. 2017. Learning technologies. *Talent Development*, 71(1), pp. 36–41.
- Kirkland, D. and O’Riordan, F. 2008. Games as an engaging teaching and learning technique: Learning or playing. Proceedings of the 1st Irish Conference on Engaging Pedagogies, Dublin, Ireland. http://icep.ie/wp-content/uploads/2010/01/Kirkland_et_al.pdf
- Kum, F.D., Cowden, R. and Karodia, A.M. 2014. The impact of training and development on employee performance: A case study of Escon Consulting. *Singaporean Journal of Business Economics, and Management Studies*, 3(3), pp. 72–105.
- Masalimova, A., Usak, M. and Shaidullina, A.R. 2016. Advantages and disadvantages of national and international corporate training techniques in employee education. *Current Science*, 111(9), pp. 1480–1485.

Petzer, D., Berndt, A. 2011. *Marketing Research*. Cape Town: Heinemann.

Poonnawat, W., Lehmann, P. and Connolly, T. 2015. Teaching business intelligence with a business simulation game. *9th European Conference on Games Based Learning: ECGBL2015*, p. 439. Reading, Berkshire: Academic Conferences and Publishing Limited.

Raybourn, E.M. 2014. A new paradigm for games: Transmedia learning for more effective training and education. *Journal of Computational Science*, 5(3), pp. 471–481.

Sardone, N.B. and Devlin-Scherer, R. 2016. Let the (board) games begin: Creative ways to enhance teaching and learning. *The Clearing House*, 89(6), pp. 215–222.

Smith, M. and Berge, Z.L. 2009. Social learning theory in *Second Life*. *Journal of Online Learning and Teaching*, 5(2), pp. 439–445.

Treher, E.N. 2011. Learning with board games: Tools for learning and retention. The Learning Key Inc., pp. 1–10. http://www.thelearningkey.com/pdf/Board_Games_TLKWhitePaper_May16_2011.pdf

Weidman, J. and Coombs, D. 2016. Dodging marshmallows: Simulations to teach ethics. *Technology and Engineering Teacher*, 75(7), pp. 14–18.

AN EXPLORATORY RESEARCH STUDY ON UNCIVILIZED BEHAVIOUR BASED ON MASS MEDIA EXPOSURE: A CASE STUDY OF CHINESE OUTBOUND TOURISTS

Ying Wang, Xiaoqin He, Nan Bi
Northeast Normal University, China

ABSTRACT

Civilized tourism can not only directly reflect the quality of tourists themselves, but can also show the image and soft power of the source country. However, the frequent uncivilized behaviour of people from some countries will not only cause dissatisfaction and resentment for others, but also undermine the image of the country. In recent years, there has been mass media exposure of uncivilized behaviour of tourists predominantly from China. Therefore, this study uses the method of network text analysis, with the mass media coverage as the research sample. This paper employs the ROST Content-Mining software to explore the uncivilized behaviour of Chinese outbound tourist and to explore the factors leading to uncivilized behaviour. Eventually, this will lead to civilized Tourism

Keywords: Chinese outbound tourists, customer misbehaviour, network text analysis, civilized tourism, mass media.

INTRODUCTION

With the process of globalization, people's living standards have gradually increased, with more and more consumers focused on the pursuit of spiritual satisfaction, and travel has gradually become a mass consumer activity. At the same time, with the rapid development of outbound travel, more Chinese tourists choose to go abroad. According to the China National Tourism Administration, the number of Chinese outbound tourists was 107 million in 2014, breaking through 100 million. The number of Chinese outbound tourists reached 117 million in 2015 and reached 122 million in 2016. However, with the rapid growth in the number of Chinese outbound tourists, some tourists' uncivilized behaviours are also increasing, causing widespread attention of public media in the Internet, such as "Chinese tourists made trouble at the Korea Airport", "Chinese tourists shoved shrimp crazily at buffet in Thailand" and so on are examples that have become topics of the mass media coverage. The performance of various uncivilized behaviours of Chinese outbound tourists not only affect their own image, but also affect the travel experiences of other tourists, undermine tourism resources, and even affect the image of a Chinese state of ceremonies. Therefore, this paper aims to find out the specific uncivilized behaviour of Chinese outbound tourists and to classify the conduct by collecting news of Chinese tourists' uncivilized behaviours. Based on this information, this study puts forward the corresponding management strategies for Chinese outbound tourists, travel agencies and the mass media in order to shape a good image of Chinese outbound tourists.

CUSTOMER MISBEHAVIOUR

The Concept of Customer Misbehaviour

Through a summary of the previous literature, it was found that the study of customer misbehaviour has attracted the attention of academia. However, at present, there is no clear definition of the concept of customer misbehaviour. Customers who exhibit misbehaviour are referred to as a "jay customer" (Lovelock, 2001),

“problem customer” (Woo & Fock, 2004) and so on. Similarly, customer misbehaviour is known as “customer aberrant behavior” (Fullerton & Punj, 1993), “customer inappropriate behaviour” (Strutton, et al., 1994), “dysfunctional customer behaviour” (Harris & Reynolds, 2003), “failure of other customers” (Huang, 2008); and so on. Based on this information, this study uses the concept of customer misbehaviour that is widely cited, that is, customer misbehaviour refers to the service contact; where the customers deliberately violate the generally accepted norms of behaviour in the context of consumption, thus undermining the consumer order, and bringing influence and interference of the service experience of both the service provider and the customer (Fullerton & Punj, 2004; Fei Xianzheng & Xiao Shengnan, 2013).

As the misbehaviour identified in the field of marketing, the author emphasizes customers in violation of behaviour norms in the consumption situation, so that the customer misbehaviour extends to the behaviour of tourists, and is known as the tourists’ uncivilized behaviour. There is no uniform standard for uncivilized behaviour of tourists from China. Lin Yubin (2010) put forward the uncivilized behaviour of tourists refers to the tourists’ behaviours do not conform to the tourism activities in the process of food, accommodation, traffic, travel, shopping, entertainment in the destination. Meng Lijuan (2014) think that tourists’ uncivilized behaviour exists between the normal behaviour and the illegal behaviour of tourists in tourism activities, and it can cause an adverse effect on the tourism resources, environment, residents, other tourists and even themselves. In summary, this study defines the tourists’ uncivilized behaviour; in destinations, tourists’ behaviour in violation of commonly accepted norms in the context of tourism, and can cause harmful effects on the destination residents, other tourists and tourism resources.

The Influencing Factors of Customer Misbehaviour

The current research on influencing factors of customer misbehaviour mainly focuses on the two aspects of customers’ personal characteristics and the enterprise consumption situation. Personality traits and demographic variables are the main drivers of customer misbehaviour (Fullerton & Punj, 1993; Daunt & Harris, 2011). From the enterprise consumption context, improper responses of the service staff or service companies that do not promptly deal with other customers’ misbehaviour will lead to additional customer misbehaviour (Huang, 2008).

In the tourism service environment, tourists share the service environment with other tourists when they consume services (Wu, 2007). Therefore, in the field of tourist behaviour research, tourists’ satisfaction is often derived from the behaviour and characteristics of other tourists as a tourist service experience, and tourists’ uncivilized behaviour also affects the satisfaction of other tourists. Bitner et al. (1994) collected 700 customer events from airlines, hotels and restaurants, and they pointed out that problem customers were a source of 22% of unsatisfactory events. Wu (2007) also found that the failure of other customers would reduce the degree of customer loyalty and satisfaction with the service enterprises in the tourism services industry.

The Consequences of Customer Misbehaviour

The study of the consequences of customer misbehaviour mainly concentrates on the negative impacts. Harris & Reynolds (2003) found that customer misbehaviour would have a series of negative effects on service firms, service employees and the fellow customers by exploring and describing the consequences of customer misbehaviour in service contact. Specifically, customer misbehaviour not only results in direct and indirect economic losses to service firms, but also has long-term psychological, short-term emotional, behavioural and physical impacts on the frontline staff (Harris & Daunt, 2013), and may even endanger the safety and lives of employees (Huefner & Hunt, 2000), as well as undermine the consumer experience of the fellow customer (Yi & Gong, 2008). In the field of tourism, the uncivilized behaviour of tourists will not only affect their own image, but also affect other tourists and local residents, damage the tourism resources and the public environment, and even affect the national image and national tourism competition force.

RESEARCH DESIGN

Research Method

This study adopts the method of network text content analysis. Content analysis is an objective, systematic and quantitative description and analysis of the explicit content of various forms of information dissemination (Yin Xiaona & Zheng Xiangmin, 2015; Jiao Niantao et al., 2016). Content analysis was originally applied to journalism, communication, and later also used in marketing and tourism research. In recent years, with the development of the Internet, especially the use of the Internet in the study of tourism, network text content analysis (as a new qualitative research method) combines the Internet information and the traditional content analysis method, and has received unprecedented favour (Chen Ganghua & Huang Yuanshui, 2008). Therefore, this paper uses the network text content analysis method to deal with Chinese tourists' uncivilized behavior in outbound tourism.

Research Process

(1) Selection of research objects. The research objects of this paper are the uncivilized behaviours of Chinese outbound tourists in Thailand, Japan and Korea from January 1, 2014 to December 31, 2016. First of all, according to the China National Tourism Administration statistics, Chinese outbound tourists exceeded 100 million in 2014; therefore, nearly three years of Chinese outbound tourists' uncivilized behaviours were chosen for this study. Secondly, for the choice of outbound destination country, according to statistics, in addition to Hong Kong, Macao and Taiwan regions, Chinese outbound tourists preferred destination countries include Thailand, Japan and Korea; therefore, this study mainly collected uncivilized behaviour of Chinese outbound tourists in the above three preferred destination countries.

(2) Selection of study samples. The samples of this study are the mass media coverage of the Internet. The mass media refers to the open news in the Internet, including the paper media (newspapers) and electronic media (radio and television). The main features of mass media are as follows: the content of the report has the distinction between domestic and overseas; the content of the report is complete and true; and the content of the report has great influence. With the rise of the Internet as a "new electronic media", the Internet has gradually become a new media type; the common mass media forms are text, pictures and video. With the development of the Internet, there are many ways to obtain samples of outbound tourists' uncivilized behaviour. This study selected the mass media in the Internet (rather than selecting self-media including micro-blogs, blogs and so on) because of the following considerations: first, the quality of mass media publishers is higher, and the contents are binding; second, the mass media' information is objective, and can be guaranteed as true and effective. However, by searching for the main keywords, we found that there are a lot of mass media reports on the Internet; for example, through the Baidu search keyword "Chinese tourists' outbound uncivilized behaviour", relevant terms of more than 700,000 were obtained. Therefore, the screening criteria for the selected mass media coverage in this study are as follows: from the time of the mass media coverage, taking into account the changes in the number of outbound tourists from China, the selected time range is from January 1, 2014 to December 31, 2016; from the sources of the mass media coverage, mainly in the following two ways: first, reports in the mass media websites should come from some well-known search engines such as Baidu, Sogou and Bing search engines, and second, from Baidu, Youku and Phoenix video search results; from the content of the mass media coverage, the content of the reports must be true, complete and a detailed description of Chinese outbound tourists' uncivilized behaviour in the destination countries.

(3) Research text processing. The network text collection work of this study was conducted from November 15, 2016 to March 15, 2017. Based on the above criteria, after rigorous screening, this study collected a total of 439 effective mass media coverage (a total of 321 are reports and a total of 118 are videos), among them, a total of 181 reports come from the Chinese tourists' uncivilized behaviours in Thailand, a total of 146 reports come from the Chinese tourists' uncivilized behaviours in Japan, and a total of 112 reports come from the Chinese tourists' uncivilized behaviours in Korea, with a total of 244268 words. Therefore, the above content forms the text analysis

data of this study, and we use the content analysis software ROST Content-Mining software to perform the statistical analysis of high frequency characteristic words.

RESEARCH RESULT

Text Time Analysis Results

Through the time analysis of the mass media overages on the uncivilized behaviour of Chinese outbound tourists, we get the results shown in table 1. The results show that the uncivilized behaviour of Chinese tourists in Thailand is the largest in 2015, but in 2016, the number of uncivilized behaviours declines and is lower than in 2014; The number of uncivilized behaviours of Chinese tourists in Japan is also the largest in 2015, the quantity decline in 2016, but much higher than the number in 2014; The uncivilized behaviour of Chinese tourists in Korea increases gradually from 2014 to 2016. But on the whole, the number of uncivilized behaviours of Chinese tourists in destination countries is the largest in 2015, and the quantity decrease in 2016, but higher than in 2014.

Table 1: Time variation trend of uncivilized behaviour of Chinese tourists in destination countries

Country \ Time	2014	2015	2016	Total
Thailand	54	106	21	181
Japan	12	69	65	146
Korea	13	45	54	112
Total	79	220	140	439

Text Content Classification Results

The classification of uncivilized behaviour of Chinese outbound tourists is mainly divided into three categories, namely, immoral uncivilized behaviour, illegal uncivilized behaviour and alienated uncivilized behaviour. Immoral uncivilized behaviour refers to uncivilized behaviour displayed by the outbound tourists because of the lack of social morality consciousness and social public morality principle, such as littering, spitting, uncivilized toilet and so on; Illegal uncivilized behaviour refers to illegal behaviour of outbound tourists due to violation of local social rules and laws are labeled “uncivilized” behaviour, such as ignoring the no smoking signs to smoke, wasting food while eating at buffet, leaving the hotel with non-gifts and so on; Alienated uncivilized behaviour refers to the behaviour of outbound tourists who violate local customs, taboos and so on, because they are unfamiliar with foreign cultures, or there is a big difference between native culture and foreign culture, such as eating while walking, bargaining, touching goods by hand and so on.

Through the analysis of the text content, we get the research results as shown in table 3. The following results can be analyzed by the data in the table. First of all, on the whole, the immoral uncivilized behaviour of Chinese outbound tourists is the most, while the alienated uncivilized behavior is the least. Secondly, From the year of view, the number of immoral uncivilized behaviour is the largest in 2015, reaching more than three times the number of uncivilized behavior in 2014, while the number declines in 2016; the number of illegal uncivilized behaviour is the most in 2016, almost two times the uncivilized behavior in 2014; the number of alienated uncivilized behaviour is also the largest in 2015, but the number of uncivilized behaviour reduces to less than half in 2016. Finally, from the outbound destination country of view, the immoral uncivilized behaviour of Chinese outbound tourists is the most in Thailand and Korea, and the illegal uncivilized behaviour and alienated uncivilized behaviour are the most in Japan.

Table 3: Classification statistics of uncivilized behaviour of Chinese tourists in destination countries

Country \ Category	Immoral uncivilized behaviour			Total	Illegal uncivilized behaviour			Total	Alienated uncivilized behaviour			Total
	2014	2015	2016		2014	2015	2016		2014	2015	2016	
Thailand	80	231	17	328	19	25	13	57	2	5	1	8
Japan	19	93	78	190	7	98	33	138	4	62	5	71
Korea	17	91	60	168	4	23	61	88	0	0	25	25
Total	116	415	155	686	30	146	107	283	6	67	31	104

CONCLUSION AND DISCUSSION

This study analyzes the collected mass media overages through the method of network text analysis. First of all, from the year of view, nearly three years, the number of reports of Chinese tourists' uncivilized behaviour is the largest in 2015, and the number of mass media reports reduces in 2016, but more than in 2014. The analysis of this phenomenon can be found, Chinese outbound tourists' uncivilized behaviour which the mass media reported has attracted the attention of outbound tourists, and outbound tourists pay more and more attention to their own words and deeds when travelling overseas, thus uncivilized behaviour also decreases. Secondly, from the point of view of classification of uncivilized behaviour, the uncivilized behaviour of Chinese tourists in foreign countries is still dominated by immoral uncivilized behaviour, while the number of alienated uncivilized behaviour is the least. Analysis of this phenomenon, we can find that the quality of Chinese tourists is uneven, the experience and tourism knowledge are insufficient, and the fear of social morality is weakening, which will lead to a lot of uncivilized behaviours. Finally, from the destination country of view, the number of uncivilized behavior of Chinese outbound tourists is the most in Thailand, which may be related to the choice of destination country of Chinese outbound tourists. In the above three destination countries, Thailand receives the largest number of Chinese outbound tourists, and thus there will be reported more uncivilized behaviour.

Based on the above analysis, as well as the uncivilized behaviour of Chinese outbound tourists brings about a series of negative impacts. Uncivilized behaviour will not only lead to the complaint and resentment of residents of tourism destination countries, and will lead to the dissatisfaction of Chinese citizens to some of Chinese outbound tourists, and even will affect the quality of other tourists in same scene, resulting in the conflict between tourists and tourists, and finally this will be indirectly bring negative impacts on the scenic spots. Based on this, this study proposes the following management implications. First of all, Chinese travel agencies should increase the management of civilized behaviour of outbound tourists and give detailed explanations before traveling, so this can improve the quality of tourists, and shape a good tourism image of china. Secondly, the mass media should advocate civilized tourism and actively promote positive energy civilization in tourism. According to the tourists' uncivilized behaviour, the mass media should keep calm and objective, and will be displayed the real reports in front of the public. Also, the mass media should positive analysis and condemn various uncivilized tourism phenomenon and its adverse effects, and should not deliberately exaggerate and distort the truth. Finally, the Chinese tourists should face up to the mass media reports, as well as use this as a guide to regulate their own tourism behaviour and to curb the occurrence of uncivilized behaviour, so that all of the outbound tourists can make civilized travel.

ACKNOWLEDGEMENT

This study was supported by "research on the psychological mechanism and effect of customer rage in service contact" of the Education Department of Jilin Province of China (NO. 2016475).

REFERENCES

- Bitner, M., Booms, B., & Mohr, L. (1994). Critical Service Encounters: The Employee's Viewpoint. *The Journal of Marketing*, 95-106.
- Chen Ganghua, & Huang Yuanshui. (2008). A Study on the Motivations of Repeat Tourists——Perspective from Web-based Content Analysis and Online Survey. *Journal of Beijing International Studies University*, 30(1):1-6.
- Daunt, K., & Harris, L. (2011). Customers Acting Badly: Evidence from the Hospitality Industry. *Journal of Business Research*, 64(10):1034-1042.
- Fei Xianzheng, & Xiao Shengnan. (2013). An Exploratory Research on Fellow Customer's Reaction to Customer Misbehavior. *Journal of Marketing Science*, 2013, 9(2):13-38.
- Fullerton, R., & Punj, G. (1993). Choosing to Misbehave: A Structural Model of Aberrant Consumer Behavior. *Advances in Consumer Research*, 20, 570-574.
- Fullerton, R., & Punj, G. (2004). Repercussions of Promoting an Ideology of Consumption: Consumer Misbehavior. *Journal of Business Research*, 57(11):1239-1249.
- Harris, L., & Daunt, K. (2013). Managing Customer Misbehavior: Challenges and Strategies. *Journal of Services Marketing*, 27(4):281-293.
- Harris, L., & Reynolds, K. (2003). The Consequences of Dysfunctional Customer Behavior. *Journal of service research*, 6(2): 144-161.
- Huang, W. (2008). The Impact of Other-customer Failure on Service Satisfaction. *International Journal of Service Industry Management*, 19(4):521-536.
- Huefner, J., & Hunt, K. (2000). Consumer Retaliation as a Response to Dissatisfaction. *Journal of Consumer Satisfaction, Dissatisfaction and Complaining Behavior*, 13: 61-82.
- Jiao Niantao, Zheng Xiangmin, & Yin Jie. (2016). An Research and Analysis on Chinese Tourists' Uncivilized Behaviors in Terms of Web Texts. *Journal of Xi'an University of Architecture & Technology (Social Science Edition)*, 35(3):46-53
- Liu Lili. (2014). Management Strategy and Psychology Analysis of Outbound Tourist Uncivilized Behavior. *Journal of Wuhan Polytechnic*, (5):99-103
- Lin Yubin. (2010). Analysis of the Connotation of Uncivilized Behavior of Tourists in the Scenic Area. *Chinese Foreign Entrepreneurs*, (1):167-168.
- Lovelock, C. (2001). *Services Marketing: People, Technology, Strategy*. Englewood Cliffs, NJ: Prentice Hall.
- Meng Lijuan. (2014). Research on the Reasons and Countermeasures of Uncivilized Travel Behavior. *Management & Technology of SME*, (3):169-170.
- Reynolds, K., & Harris, L. (2009). Dysfunctional Customer Behavior Severity: An Empirical Examination. *Journal of Retailing*, 85(3):321-335.
- Strutton, D., Vitell, S., & Lou, E. (1994). How Consumers May Justify Inappropriate Behavior in Market Settings: An Application on the Techniques of Neutralization. *Journal of Business Research*, 30(3):253-260.

Woo, K., & Fock, H. (2004). Retaining and Divesting Customers: an Exploratory Study of Right Customers, “at-risk” Right Customers, and Wrong Customers. *Journal of Services Marketing*, 18(3):187-197.

Wu, H. (2007). The Impact of Customer-to-Customer Interaction and Customer Homogeneity on Customer Satisfaction in Tourism Service—the Service Encounter Prospective. *Tourism Management*, 28(6):1518-1528.

Yi, Y., & Gong, T. (2008). The Effects of Customer Justice Perception and Affect on Customer Citizenship Behavior and Customer Dysfunctional Behavior. *Industrial Marketing Management*, 37(7):767-783.

Yin Xiaona, & Zheng Xiangmin. (2015). A Study of the Tourists’ Cultural Perception of the Three Lanes and Seven Alleys Based on Network Text Analysis. *Journal of Beijing International Studies University*, (9):62-66.

REGIME SWITCHING OF MONETARY POLICY AND DETECTABILITY

Varang Wiriyawit
Mahidol University International College, Thailand

ABSTRACT

A regime switching of monetary policy from indeterminacy to determinacy can change the dynamic of economy and shock propagations significantly. Whether business owners can detect the switching of the regime is then crucial as this information can provide opportunities or even risks that might arise in the business environment. By using Monte Carlo experiments, the results show that business owners might be unaware of the regime switching if the difference is not too large. Specifically, they can only observe the change 80% of the times when the degree of monetary responses to inflation is already 50% different from the benchmark.

Keywords: Structural Change, Indeterminacy, Structural Break Test, Monetary Policy

INTRODUCTION

Changes in economic environment have been studied in many aspects. For instance, Hidalgo C.A., Hausmann R. and Dasgupta P.S. (2009), Silva and Teixeira (2011) and Saviotti and Pyka (2012) study changes in demand (i.e. changes in sectoral composition and in economic specialization by boosting technological innovation and creating new products) which lead to more diverse and complex products available in a market and contribute positively to economic growth. There are also studies on changes in economic environment specifically in different countries such as Dempster and Isaacs (2014) examine the structural change in the U.S. economy from 1850 to 1900, Hartwig (2015) investigate the structural change in aggregate demand and employment in OECD countries and Belkhouja and Mootamri (2016) look at structural change in the G7 from 1955 to 2014. However, not only changes from private sectors, a change in policy responses from a central bank can also cause a significant impact on the dynamic and shock propagation of the whole economy. This thus leads to a change in business environment in which can be considered as opportunities if expected and might become threats if undetected. This paper therefore investigates the ability to detect the change in the responses of monetary policy to inflation.

The change in monetary responses has been discussed and explicitly shown in the literature. For example, Clarida, Galí and Gertler (2000) and Lubik and Schorfheide (2004) show that U.S. monetary policy before the 1980s is consistent with indeterminacy due to the passivity of the policy. However, Edge and Gurkaynak (2010) and Goodfriend and King (2012) show that the more active monetary policy has been taken since the mid-1980s when a central bank actively adjusts the nominal interest rate in response to inflation. The importance of this change to the economic environment is examined by Fujiwara and Hirose (2014). They find that the economy under indeterminacy can be more fluctuated and the dynamic of inflation can be quite volatile. Hence, including indeterminacy in a model can generate richer dynamics and improve forecastability. Many studies then incorporate this feature into a model used for policy evaluation and economic analysis (e.g. Zheng and Guo (2013) and Dufourt, Nishimura and Venditti (2015)). The boundary condition between the two regimes of interest is also derived and studied by, for example, Zheng and Guo (2013). However, how much we can detect the move between regimes has not yet been studied.

This paper then studies the detectability of the switching from an indeterminate regime to a determinate regime of monetary policy by designing Monte Carlo experiments with the use of Dynamic Stochastic General Equilibrium (DSGE) model as a Data Generating Process (DGP). Detectability of the structural change is evaluated by computing a fraction of times where the change can be detected correctly using Qu and Perron (2007)'s test for structural break.

MONTE CARLO EXPERIMENTS

To study this question, Monte Carlo experiments are designed to examine the ability to detect the structural change of monetary policy. This section starts by going through the description of a theoretical model used as DGP and then the setup of the experiments.

Theoretical Model

The theoretical model used in this paper is followed from Lubik and Schorfheide (2004) which is a prototypical sticky-price DSGE model and can be expressed by the following equations.

$$\tilde{y}_t = \mathbb{E}_t \tilde{y}_{t+1} - \sigma^{-1} (\tilde{\pi}_t^m - \mathbb{E}_t \tilde{\pi}_{t+1}^m) + g_t \quad (1)$$

$$\tilde{\pi}_t = \mathbb{E}_t \tilde{\pi}_{t+1} + \kappa (\tilde{y}_t - z_t) \quad (2)$$

$$\tilde{r}_t^m = \rho_r \tilde{r}_{t-1}^m + (1 - \rho_r) [\varphi_\pi \tilde{\pi}_t + \varphi_y (\tilde{y}_t - z_t)] + \varepsilon_{r,t} \quad (3)$$

$$g_t = \rho_g g_{t-1} + \varepsilon_{g,t} \quad (4)$$

$$z_t = \rho_z z_{t-1} + \varepsilon_{z,t} \quad (5)$$

where \tilde{y}_t is the percentage deviation of output from a trend path, $\tilde{\pi}_t$ is the percentage deviation of inflation and \tilde{r}_t^m is the percentage deviation of the short-term nominal interest rate from a respective steady-state value.

In this model, households solve the utility maximization problem and their optimality conditions are described by a dynamic IS equation (1) where g_t captures the net effects of AR(1) exogenous shifts on household preferences and σ is the inverse of the intertemporal substitution elasticity. Equation (2) is the New Keynesian Phillips curve representing the profit maximization problem of monopolistically competitive firms that face a Calvo-style nominal rigidity where κ is a function of the probability that firms can reoptimize their prices and the preference parameters of households and z_t represents AR(1) exogenous changes in the marginal costs of production. Equation (3) follows a Taylor-type rule describing monetary policy responses to inflation and the output gap with φ_π and φ_y as the degrees of the policy responses respectively and ρ_r as the policy smoothing parameter. $\varepsilon_{r,t}$, $\varepsilon_{g,t}$ and $\varepsilon_{z,t}$ are unsystematic components of monetary policy, g_t and z_t and assumed to be uncorrelated with each other.

The values of structural parameters used in DGP are shown in Table 1 in which they follow the mean values of the prior distribution in Lubik and Schorfheide (2004). The value of φ_π , on the other hand, varies per the regime of interest in this paper.

Table 1: Values of Structural Parameters used in DGP

σ	β	κ	φ_y	ρ_r	ρ_g	σ_r	σ_g	σ_z
2.00	0.995	0.70	0.25	0.60	0.70	0.31	0.38	1.00

Experiments

The structural break considered in this paper is when the economy changes from an indeterminate regime due to passive monetary policy ($\varphi_{\pi} < 1$) to a determinate regime of conducting active monetary policy ($\varphi_{\pi} > 1.1$). Several values of φ_{π} under an indeterminate regime are considered, ranging from 0.95 to 0.50, to observe the ability to detect the structural change. A sample is then simulated from the two regimes of interest. Total number of observations from DGP is 200 and the number of simulations is 1,000.

To test for a structural break, this paper follows Qu and Perron (2007) which is a test for changes in multivariate regressions. In this paper, Vector Autoregressive (VAR) model with two lags is used in the estimation. Moreover, to better capture the change from indeterminacy to determinacy, I allow for both the reduced-form coefficients and the reduced-form error variances to vary across regimes. This is because equilibrium dynamics under indeterminacy can be more volatile than their determinate counterparts as discussed in Fujiwara and Hirose (2014).

RESULTS AND DISCUSSION

Table 2 reports results from the Monte Carlo experiments which shows a fraction of times I can reject the null hypothesis of no break at 1% significance level given different degrees of policy responses to inflation under an indeterminate regime before switching to a determinate regime. As expected, when the degree of policy responses does not change much between indeterminacy and determinacy; only 10% difference from 0.95 to 1.1, I cannot statistically observe the switch in the regime that much. That is, only around 50% of the times the change can be detected. However, I can only observe the change 80% of the times when the degree of monetary responses to inflation is already 50% different from the degree under determinacy; from 0.5 to 1.1.

Table 2: A Fraction of Times Rejecting Null Hypothesis at 1% Significance Level

Value of φ_{π} under Indeterminacy	0.95	0.90	0.80	0.70	0.60	0.50
A Fraction of Times Rejecting Null Hypothesis at 1% Significance Level	55.1%	60.2%	68.1%	75.4%	75.4%	79.4%

This therefore raises a challenge for business owners as they can be unaware of risks that might arise due to the change in the monetary regime. Business owners require accurate measurement for inflation and uncertainty to design an optimal strategy and remain competitive in a market. If the occurrence of the regime switching is not accounted for properly then the decisions might be misguided.

Uncertainty occurred in the situation of regime switching can be illustrated in Figure 1. This figure plots impulse responses of a level of output (Y_t), inflation (π_t) and nominal interest rate (r_t^R) to a shock to the marginal costs of production (z_t) given different degrees of policy responses. Whenever the economy is under an indeterminate regime ($\varphi_{\pi} < 1$), the dynamic of inflation will be very volatile as a central bank would not respond by changing nominal interest rate too much. The change of inflation is also highly persistent and last many periods after the shock before converging back to the steady state. Once the regime switches to an active monetary policy ($\varphi_{\pi} > 1.1$), there will be a substantial change in interest rate given a shock to the marginal costs of production. This leads to a large change in inflation and the rate converges back to the steady state within a short period of time.

Figure 1: Impulse responses to the change in cost-push shock given different degrees of policy responses to inflation

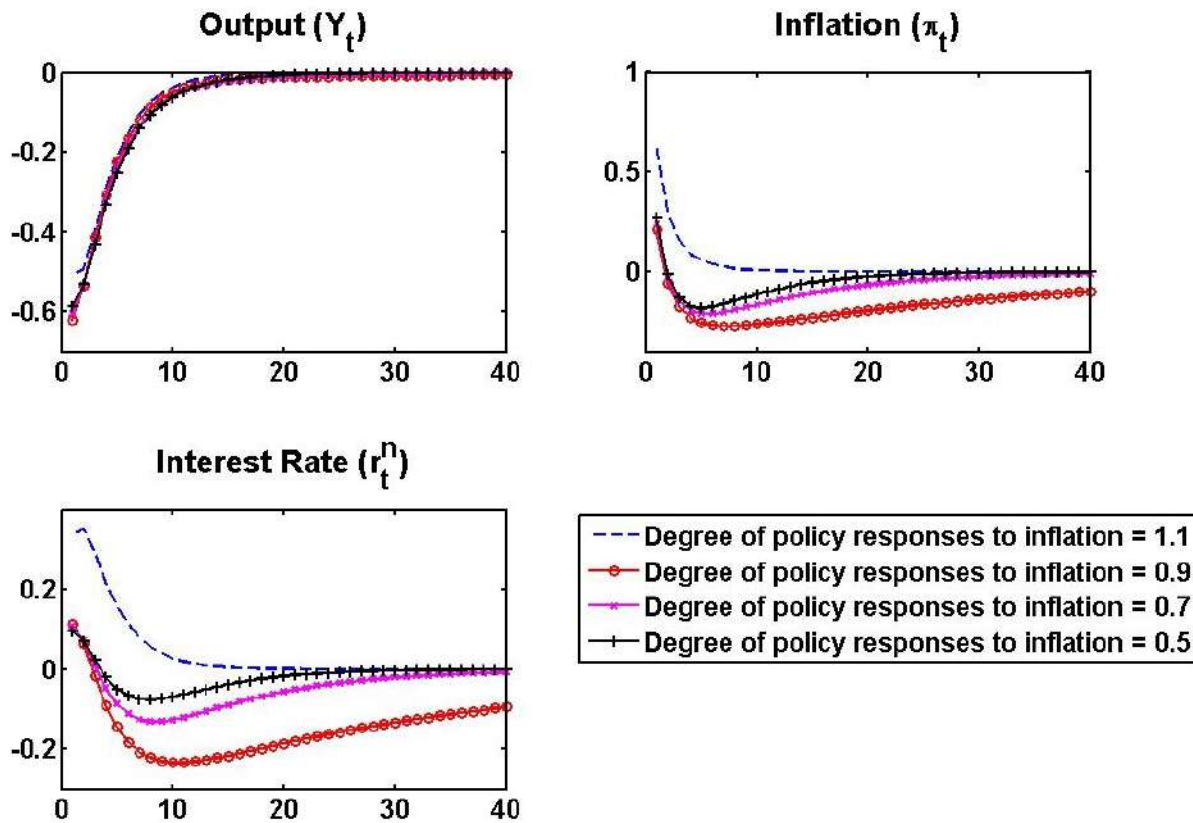

Given a considerable change in the dynamic of inflation between the two regimes of interest, business owners, especially for small businesses, might take a hit on margin if they do not have a contingency plan or prepare their business for the change. The change in interest rate as a central bank raises the rate to counter high inflation also have impact on firms' capital expenditure, especially when the regime changes to determinacy. Firms' margins are therefore squeezed as the costs of production rises without them being able to significantly pass on those increases to their customers. Low detectability of such a change in business environment thus cause business owners to bear unnecessary higher costs of production without any plan to alleviate the issue.

One way to better equip business owners with detectability might be through increasing the level of communication and greater transparency of a central bank. These communication channels can be through extensively uses of press conferences on a real-time basis, a central bank's website, monthly bulletin, etc. As discussed by, for instance, Woodford (2005), Haan and Jansen (2010) and Tomuleasa (2015), being more open to general public regarding information disclosure can increase the predictability of a central bank actions, reduce uncertainty in decision making, and eventually lead to a more effective management of business owners. Moreover, it can stabilize

CONCLUSION

This paper studies how much we can detect the change in monetary policy responses to inflation. The finding shows that business owners might be unaware of the switching if the difference of the degree of policy responses between the two regimes of interest is not too large. Specifically, they can only observe the change 80% of the times when the degree of monetary responses to inflation is already 50% different from the benchmark. This raises a red flag for business owners, especially small businesses, to be mindful of how a central bank responds to a change in inflation.

This is because the switch in monetary regime can have a substantial impact to the dynamic of the economy and consequently a level of profit businesses can earn.

Given such difficulty in detecting the switch of monetary regimes found in this paper, the future research to be considered is then to investigate for additional characteristics of the dynamics in which can be used to improve the detectability of a structural break that might occur in the business environment. The improvement of the detectability in such fast-paced environment would benefit business owners in making more effective decisions.

REFERENCES

- Belkhouja M. and Mootamri I. (2016). Long Memory and Structural Change in the G7 Inflation Dynamics. *Economic Modelling*, 54, 450-462.
- Clarida R., Galí J. and Gertler M. (2000). Monetary Policy Rules and Macroeconomic Stability: Evidence and Some Theory. *The Quarterly Journal of Economics (Oxford University Press)*, 115(1), 147-180.
- Dufourt F., Nishimura K. and Venditti A. (2015). Indeterminacy and Sunspots in Two-Sector RBC Models with Generalized No-Income-Effect Preferences. *Journal of Economic Theory*, 157, 1056-1080.
- Edge R.M. and Gurkaynak R.S. (2010). How Useful are Estimated DSGE Model Forecasts for Central Bankers?. *Brooking Papers on Economic Activity (Economic Studies Program, The Brooking Institution)*, 41(2), 209-259.
- Fujiwara I. and Hirose Y. (2014). Indeterminacy and Forecastibility. *Journal of Money, Credit and Banking*, 46(1), 243-251.
- Goodfriend M. and King R.G. (2012). The Great Inflation Drift. *NBER Chapters in The Great Inflation: The Rebirth of Modern Central Banking*, 181-209.
- Haan, J., Jansen, D., (2010). The Communication Policy of the European Central Bank: An Overview of the First Decade. *The European Central Bank at Ten*, 119-141.
- Hartwig J. (2015). Structural Change, Aggregate Demand and Employment Dynamics in the OECD, 1970-2010. *Structural Change and Economic Dynamics*, 34, 36-45.
- Hidalgo C.A., Hausmann R. and Dasgupta P.S. (2009). The Building Blocks of Economic Complexity. *Proceedings of the National Academy of Sciences of the United States of America*, 106(26), 10570-10575.
- Lubik T. and Schorfheide F. (2004). Testing for Indeterminacy: An Application to U.S. Monetary Policy. *American Economic Review*, 94, 190-217.
- Qu Z. and Perron P. (2007). Estimating and Testing Structural Changes in Multivariate Regressions. *Econometrica*, 75(2), 459-502.
- Saviotti P.P. and Pyka A. (2012). On the Co-Evolution of Innovation and Demand: Some Policy Implications. *Revue de l'OFCE*, 124(5), 347-388.
- Silva E.G. and Teixeira A.A.C. (2011). Does Structure Influence Growth? A Panel Data Econometric Assessment of "Relatively Less Developed" Countries, 1979-2003. *Industrial and Coporate Change*, 20(2), 457-510.
- Tomuleasa, I. (2015). Central Bank Communication and its Role in Ensuring Financial Stability. *Procedia Economics and Finance*, 20, 637-644.

Woodford, M., (2005). Central Bank Communication and Policy Effectiveness. *Federal Reserve Bank of Kansas City Journal Proceedings*, 399-474.

Zheng T. and Guo H. (2013). Estimating a Small Open Economy DSGE Model with Indeterminacy: Evidence from China. *Economic Modelling*, 31, 642-652.

MARKET SEGMENTATION USING CLUSTER ANALYSIS AND COMBINATORIAL FUSION

Zhenning Xu, University of Southern Maine, U.S.A.

D. Frank Hsu, Fordham University, U.S.A.

Weihua Gan, East China Jiaotong University, China

Ting Geng, City University of London, U.K.

Christina Schweikert, St. John's University, U.S.A.

ABSTRACT

Cluster analysis (CA) has been widely used in business to conduct market segmentation. However, since CA is an unsupervised learning method, it remains a challenge to evaluate the validity of the result. In particular, marketing strategy will not have the effect until months or years after it is executed. In this paper, we propose a new approach to conduct market segmentation using combinatorial fusion (CF). When using multiple attributes to estimate customer value, the CF method treats each of the attributes as a scoring system. Various CF algorithms enable us to combine these scoring systems more efficiently and effectively using the rank-score characteristic (RSC) function and the notion of cognitive diversity (CD). We demonstrate that the CF method not only can complement and validate CA results, it can also contribute tremendously to customer relationship management (CRM) in managing customer tiers with data-driven solutions.

Keywords: Cognitive diversity, Combinatorial fusion, Cluster analysis, Market segmentation, Rank-score characteristic function (RSC Function).

INTRODUCTION

Market segmentation has become an important technique, both in marketing theory and in practice (Rao & Steckl 2008). The technique has several benefits over mass marketing. It provides ample opportunity to observe underlying patterns of a homogeneous market. It can also optimize performance for potential market maximization for each segment with better targeting strategies.

Cluster analysis (CA) has been used widely in business to conduct market segmentation in past decades. Several CA methods have been used such as k-means, Ward clustering, and hierarchical clustering. However, since CA methods are unsupervised learning methods, it remains a challenging task to evaluate the validity of the result. Therefore, the validation process beyond “clustering algorithms” may provide new insights on clustering results. In this paper, we propose a new approach to conduct market segmentation using combinatorial fusion (CF) (Hsu et al 2006, Hsu et al 2010, Hsu & Taksa 2005).

When using multiple attributes to estimate customer value, the CF method treats each of these attributes as a scoring system. The scoring system A consists of a score function s_A , a rank function r_A , and a rank-score characteristic (RSC) function f_A . The notion of cognitive diversity (CD) between two scoring systems (attributes) A and B is defined as $d(A,B) = d(f_A, f_B)$, the difference between RSC functions f_A and f_B which characterizes the ranking (and scoring) behavior of attributes A and B, respectfully.

Customer segmentation has not been an important technique until recently. Depending on the type of company, most firms have in the past relied on internal information, such as annual sales and cost reduction, to improve performance. However, efficient utilization of external customer information may also reveal important insights for performance improvement. This would enable companies to identify other customer characteristics such as transaction frequency (TF). It would also provide a strategy to attract new customers and retain existing customers. This suggests the importance of recency (R), which measures the time elapsed since a customer's most recent purchase (or order). Monetary (M) value gives the amount of money the customer spent during a period of time (Blattberg et al 2008, Bult & Wansbeek 1995).

SEGMENTATION OF VIPS USING CLUSTER ANALYSIS

RFM is one of the most popular customer segmentation models in customer relationship management (CRM). The RFM model uses multi-dimensional means to estimate customer value beyond profitability. The RFM model uses three attributes: Recency (R), Frequency (F), and Monetary (M) value. While recency alone may not be able to sort out good customers from a large pool of occasional customers, firms, by focusing on recency, may be able to increase retention rate or transform occasional to loyal customers. Frequency (F) measures the intensity of a customer's relationship with a company, which can be captured by how often the customer has purchased products (or services) during a period of time. Monetary (M) value, as defined before, means the amount of money the customer spent in a time span (Blattberg et al 2008, Bult & Wansbeek 1995).

Hierarchical clustering methods are used to estimate dissimilarity among observations (or attributes). It is useful for relatively smaller datasets and the basic algorithm of measurement is Euclidean distance. In this paper, we choose three clustering methods: Centroid, Complete linkage, and Ward's method to perform initial clustering. The centroid method measures the distance between two clusters by using the distance between their centroids. Complete linkage measures the maximum distance between two clusters. It tends to find clusters of equal size in terms of the volume of space they occupy, making it suitable for customer segmentation. Ward's method merges two clusters whenever the increment of the sum of squares for variation is as small as possible.

Based on the outcome of clustering analysis, the number of target customers with different combinations of R, F, and M can be identified and ordered from the most valuable segments (highest recency, frequency, and value) to the least valuable segments (lowest recency, frequency, and value). The combination of these indicators characterizes both financial and behavioral measurements of customers' profiles. Therefore, clustering methods based on RFM rule out short-term strategy solely relying on financial outcomes by providing market intelligence for long-term strategic decisions. The RFM model exhibits the customer's multidimensional profile and provides the proven metric evidence for customized communication and service. Hence the RFM model can be adopted to improve market performance.

SEGMENTATION OF VIPS USING COMBINATORIAL FUSION

Combinatorial fusion (CF) is an emerging method for scientific discovery which deals with machine learning, pattern recognition, data mining, classification, and information fusion (Hsu et al 2006, Hsu et al 2010). The method and its related techniques have been used in several domain applications, such as information retrieval (Hsu & Taksa 2005), wireless network selection (Kustiawan et al 2017), video target tracking (Lyons & Hsu 2009), portfolio management (Vinod et al 2010), and virtual screening (Yang et al 2005). CF provides guidelines as to "when" and "how" to combine multiple scoring systems. In this section, we discuss various ways to combine the three scoring systems R, F, and M constructed by the three attributes in customer segmentation: Recency, Frequency, and Monetary value, respectfully.

Let $D = \{d_1, d_2, \dots, d_n\}$ be a set of n customers and $N = [1, n]$ be the set of all positive integers between and including 1 and n . Let R be the set of real numbers. Let A be any of the three attributes $R, F,$ and M , i.e. $A \in \{R, F, M\}$. The scoring system A consists of a score function s_A , from D to R , and a rank function r_A , obtained by sorting the values of the score function in descending order to become a function from D to N . The rank-score characteristic (RSC) function f_A is defined as: $f_A(i) = (s_A \cdot r_A^{-1})(i) = s_A(r_A^{-1}(i))$ from N to R . For the purpose of uniformity across different scoring systems, each score function is normalized to become a function from D to $[0, 1]^*$ consisting of real numbers between and including 0 and 1. The RSC function f_A of the attribute A , $A \in \{R, F, M\}$, characterizes the ranking (or scoring) behavior of the attribute A .

For two scoring systems A and B representing any two of the three attributes $R, F,$ and M , the notion of cognitive diversity (CD) between A and B is defined as the difference between f_A and f_B . It can be computed as:

$$d(A, B) = d(f_A, f_B) = (\sum_{i=1}^n (f_A(i) - f_B(i))^2) / n.$$

If the area between f_A and f_B is sufficiently large, the two attributes A and B are considered cognitively diverse. It was shown (Hsu & Taksa 2005, Yang et al 2005) that combination by rank can outperform combination by score under certain conditions which include the cognitive diversity between A and B .

Let s_A, r_A, s_B, r_B , be the score functions and rank functions for scoring systems A and B , respectively. Let E be the score combination of A and B , i.e. $E = SC(A, B)$ and $s_E(d_i) = (s_A(d_i) + s_B(d_i))/2$. The rank function of E , r_E is obtained by sorting the values in $s_E(d_i)$ in descending order. On the other hand, let G be the rank combination of A and B , i.e. $G = RC(A, B)$ and $s_G = (r_A(d_i) + r_B(d_i))/2$. The rank function of G , r_G is obtained by sorting the values of $s_G(d_i)$ in ascending order.

In this paper, we treat each of the three attributes $R, F,$ and M as a scoring system A . Score function s_A is constructed by the collected data, the set of customer information. Suppose the i^{th} through $(i+q)^{\text{th}}$ scores have the same score, these q customers will be assigned the same rank $(i+(i+q))/2 = i + q/2$. It follows that the customer with the next (i.e. $(i+q+1)^{\text{th}}$) score will be given the rank $i+q+1$. This resolution to address the same rank phenomena is needed in particular when the score function is a result from the combination of multiple score functions.

MARKET SEGMENTATION USING CA AND CF

Based on the previous two sections, we conduct customer segmentation with a use case using both CA and CF, and then give a comparison of these two methods. The use case concerns a growing firm in the logistics industry (DMASSC@USM 2017). Logistics firms, much like other sectors in the industry, face tremendous competition due to rapid change of customer base and technology innovation. Most traditional firms adopt one criterion – annual shipments in the segmentation of VIP customers. But, the use of only one single criterion for segmenting customers has several disadvantages. First of all, it may ignore potential new customers who represent future growth opportunities. Second, without considering other customer characteristics, the company ignores other important factors like transaction frequency, which is also a characteristic of a loyal customer. Finally, a marketing strategy that relies solely on annual shipment, revenue, or just net income, will not reflect the entrance of new customers and exit of old customers.

Analyzing the use case using cluster analysis

Using a dataset of 135 VIP customers, we perform three hierarchical clustering algorithms to classify observations. Since there are no prior assumptions about differences within the population and the number of clusters, we mainly use two criteria to determine the number of optimal clusters. In order to find the optimal number of clusters and the best clustering method, the following statistics were used: Root Mean Squared Standard Deviation (RMSSTD), Semi-partial R-Square (SPRSQ), and R-Square (RSQ). We first use absolute value of RMSSTD, SPRSQ, and RSQ to choose the best clustering method. Then we also calculate percentage change of RMSSTD, SPRSQ, and RSQ to choose the number of clusters based on these three clustering methods (Table 1 in Appendix).

As a comparison, Gap statistics is also used to test the stability of clustering results (Tibshirani et al 2001). Following Tibshirani et al (2001), let WK stand the within-cluster sum of squares, and $W^* Kb$ be the same quantity obtained after randomly permuting the observations within each item/experiment. The main purpose of including the Gap statistic in our study is as a term of reference. This enables us to relate our results to those obtained based on a well-accepted metric that has been shown to perform reasonably well in statistics studies (Ben-Hur, Elisseeff, & Guyon 2002, Dudoit & Fridlyand 2002, Tibshirani et al 2001). As Figure 1 below shows, the estimated gap K^* is the smallest K inducing a gap within one standard deviation of the gap at $K+1$. Here the gap statistics indicate that the estimated K^* is 3. Table 1 shows that the largest percentage changes in RMSTD value, SPRSQ value, and RSQ value support for a three-cluster solution. Based on both percentage changes in above-mentioned statistics indexes and Gap statistics, 135 customers are broken down into 3 major groups.

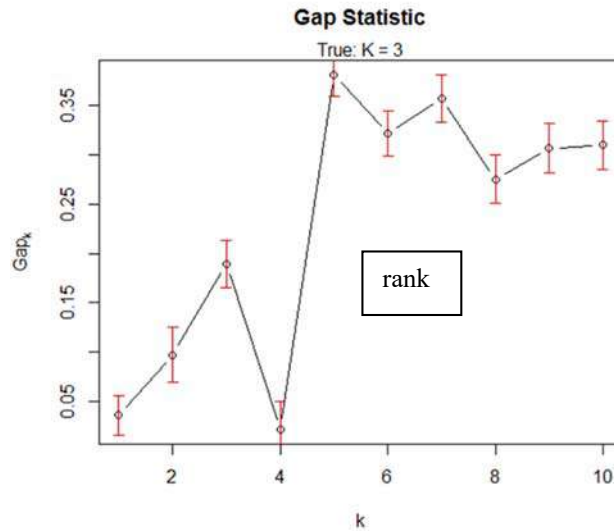

Figure 1: Using gap statistics to determine the number of clusters: The plot is a display of the gap-statistic values for each choice of number of clusters from $K=1$ (all CGFs belong to the same cluster) up to $K=10$. The error bars under each circle is the standard error for each value. The optimal number of clusters is where we see the first significant drop in gap-statistic value, i.e. where the gap statistic value $G(K)$ is such that $G(K) > G(K + 1) - SE(K + 1)$, where $SE(K + 1)$ is the standard error at $K + 1$ (Tibshirani et al. 2001).

As shown in Table 1 and Figure 1, the 135 customers are partitioned into 3 groups (clusters). The classification of these 135 customers into 3 clusters based on Ward's method is shown in Figure 2 below.

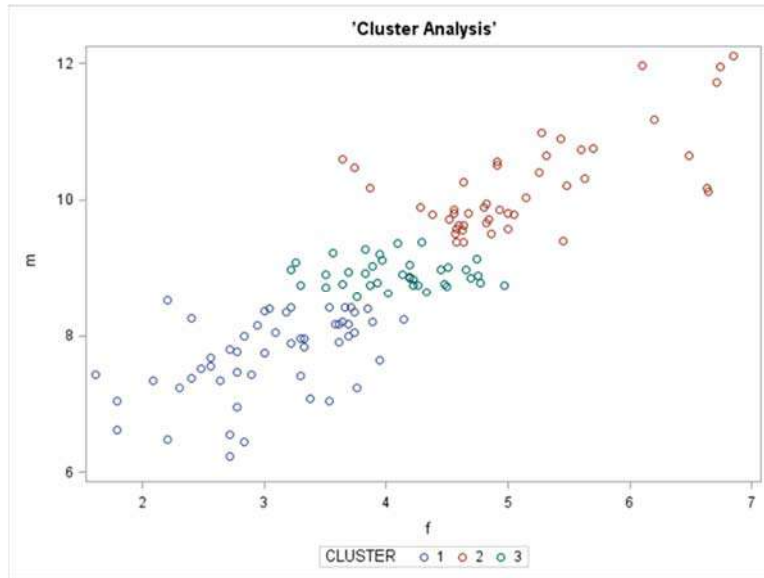

Figure 2: Clustering plot using Ward’s method: This figure shows a hierarchical clustering of 135 customers using Ward’s method. X and Y denote the natural logarithm of frequency and monetary value, respectively.

Analyzing the use case using combinatorial fusion

Here we provide computational results and visualization for our proposed combinatorial fusion method using the rank-score characteristic (RSC) function and its graph. As discussed in previous sections, we established score functions s_R , s_F , and s_M and corresponding rank functions r_R , r_F , and r_M for the three attributes (scoring systems) R (recency), F (frequency), and M (monetary value), respectively on D, the set of 135 customers. RSC functions f_R , f_F , and f_M are defined accordingly. Figure 3 below shows RSC graphs of the three RSC functions f_R , f_F , and f_M , respectively.

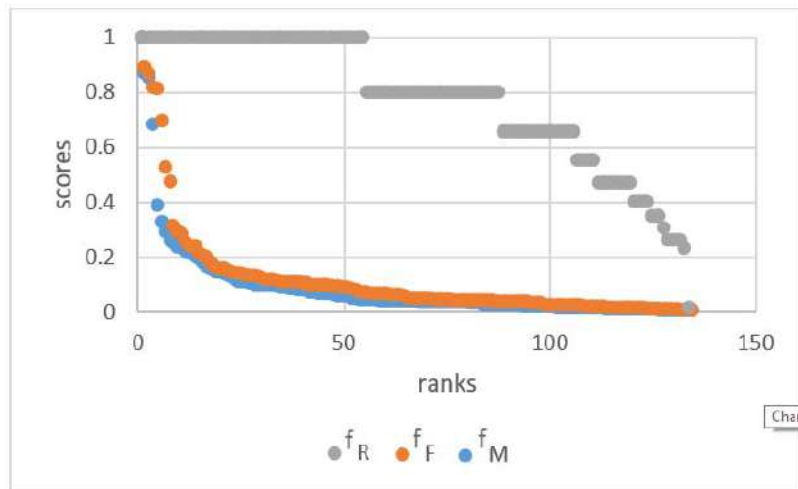

Figure 3: Individual RSC graphs of f_A , where A=R, F, or M: R (Recency) is transformed to the same numerical direction as F and M so that larger R, F, and M values represent the higher-profile VIP customers.

In Figure 3, we see that the graph curves for attributes F and M are closely located, while the curve for R is far away from these two curves. This translates to the spectrum of cognitive diversity (CD) as follows: $d(R, F)$ and

$d(R, M)$ are both larger than $d(F, M)$. Harnessing this variation of cognitive diversity, we use three algorithms, each constructing a scoring system in a process of combining these three attribute systems.

Algorithm 1 first constructs a scoring system s_{RFM} by combining the three score functions s_R , s_F , and s_M . So we write this s_{RFM} as $s(SC(R, F, M))$ to mean it as the score function of the scoring system which results from the score combination of the three score functions s_R , s_F , and s_M . Consequently, the rank function $r(SC(R, F, M))$ and RSC function $f(SC(R, F, M))$ can be derived. Figure 4 in Appendix depicts the resulting RSC function $f(SC(R, F, M))$.

Algorithm 2 first constructs a scoring system E by combining two score functions s_F and s_M , i.e.: $E=SC(F, M)$. A rank function r_E is then derived from the score function s_E . Next, we combine the two rank functions r_E and r_R to have the scoring system G , i.e.: $G=RC(r_E, r_R)$. Figure 5 in Appendix illustrates the RSC function f_G . Note that the direction of the curve of f_G is reversed since the rank combination of r_E and r_R inverses the direction of the original scoring systems.

Algorithm 3 initially has three score functions s_R , s_F , and s_M . These lead to three rank functions r_R , r_F , and r_M . Let G be the rank combination of r_R , r_F , and r_M . Sort the score function of G , s_G , in ascending order to give a rank function r_G . The monotonically non-decreasing function f_G is shown in Figure 6.

Comparison of the three CF methods with the Ward's method

Now we use Jaccard index to compare customer memberships derived from the three combinatorial fusion algorithms with cluster analysis. To measure the similarity, we use Jaccard similarity Index, which is calculated by $(A \cap B)/(A \cup B)$ of the two datasets A and B . As Table 2 in Appendix shows, there are 47 tier 1 customers with high F and M by cluster analysis. The Jaccard similarity index shows that the rank combination $RC(R, F, M)$ has the best match with the Ward clustering memberships, with 80% of customer memberships same for high profile customers, 48% for medium customers, and 70% for low profile customers. While the multiple combination $RC(SC(F, M), r(R))$ has slightly lower performance to validate Ward cluster analysis, with 77%, 45%, and 63% agreements for high, medium, and low profile customers respectively. However, the match between the score combination $SC(R, F, M)$ with the Ward cluster analysis is comparatively lower, with only 67%, 23%, and 52% agreed for high, medium, and low profile customer groups respectively. Interestingly, the similarity value shows that both two methods have better chance to identify the most important customers (those with highest F and M , while low R) and the least important customers (those with lowest F and M , while highest R). However, the similarity is lower than .50 for the customers with medium frequency, monetary value and recency.

In general, the comparison shows that multiple combination algorithms have advantageous merit over cluster analysis to classify customers into different groups due to the following reasons: 1) multiple CF algorithms are an information fusion approach to intuitively improve classification accuracy step by step; 2) multiple CF algorithms have enriched the classification technique in that the method provides a gradient representation of classifications from each observation to the subsequent one; and 3) multiple CF algorithms take consideration of the data characteristics such as diversity, and provide intuitive visualization and consensus scoring approach for better classification. Even the most conservative contribution is that multiple CF algorithms can be used to validate cluster analysis and contribute to more confidence of clustering and segmentation.

CONCLUSION AND REMARKS

The clustering methods used in this paper for customer segmentation are unsupervised, which indicates that it is difficult to validate the results of a cluster analysis. As a complementary approach, we utilize combinatorial fusion to enhance this marketing strategy. Within the combinatorial fusion framework, we combine scoring systems according to cognitive diversity information observed from the rank-score characteristic functions of the scoring systems that represent customer attributes. Specifically, if the scoring systems are diverse, a rank combination is used, otherwise a score combination is preferred. The combinatorial fusion approach can also be used to validate the results of a cluster analysis.

We demonstrate the application of cluster analysis and combinatorial fusion on a customer dataset of a logistics company that contains information on customers including the following attributes: Recency (R), Frequency (F), and Monetary (M). These attributes are used to construct scoring systems and component rank, score, and rank-score characteristic functions. The combinatorial fusion process incorporates the concept of cognitive diversity to inform system combinations. Using both a clustering analysis and a combinatorial fusion approach increases the confidence of the assignment of customers to classes.

REFERENCES

- Ben-Hur, A., Elisseeff, A., Guyon, I. (2002). A stability based method for discovering structure in clustered data, Pac Symp Biocomput. 2002, p. 6-17.
- Blattberg, R. C., & Deighton, J. Byung-Do Kim, and Scott A. Neslin (2008). *Database Marketing: Analyzing and Managing Customers*, Springer, p. 313-316.
- Bult, J. R., & Wansbeek, T. (1995). Optimal selection for direct mail. *Marketing Science*, 14(4), p. 378-394.
- Chen, Mingliang (2003). Research on Customer life cycle. *Zhejiang university academic journal*. 32(6), p. 2-7.
- Cheng, Yahui, Zhang, Yinjie (2009). Comparison on Clustering algorithm application in the customer segmentation. *Shaoyang academic journal*. 6(4), p. 69-73.
- Chiang, Wen-Yu (2011). To mine association rules of customer values via a data mining procedure with improved model: An empirical case study. *Expert Systems with Applications*. Volume 38, Issue 3, March 2011, p. 1716–1722.
- Devi, P. Isakki Alias (2013). Profiling methodology with reference to customer lifetime value relationship satisfaction and behavior using data mining techniques. Vels University. 10-Jun-2013, p.17-21.
- Dudoit, Sandrine and Fridlyand, Jane (2002). A prediction-based resampling method for estimating the number of clusters in a dataset, *Genome Biology*, 3:research0036.1.
- Hsu, D.F., Chung, Y.S. and Kristal, B. S. (2006). Combinatorial fusion analysis: methods and practices of combining multiple scoring systems. *Advanced Data Mining Technologies in Bioinformatics* Idea Group Inc, p. 32-62.
- Hsu, D.F., Kristal, B.S. and Schweikert, C. (2010). Rank-score characteristics (RSC) function and cognitive diversity. *Brain Informatics 2010, Lecture Notes In Artificial Intelligence*, Yiyu Yao, Ron Sun, Tomaso Poggio, Jiming Liu, and Ning Zhong (Eds.), Springer-Verlag Berlin Heidelberg, p. 42-54.
- Hsu, D.F. and Taksa, I. (2005). Comparing rank and score combination methods for data fusion in information retrieval. *Information Retrieval*, 8, p.449-480.
- Hughes, A.M. (1995). Making database pay off using recency, frequency and monetary analysis. *Journal of Database Marketing*, 3, p.77-89.
- Kustiawan, I., Liu, C.-Y., and Hsu, D.F. (2017). Vertical handoff decision-making using fuzzification and combinatorial fusion, *IEEE Communications Letters*.
- Lyons, D.M., and Hsu, D.F. (2009). Method of Combining Multiple Scoring Systems for Target Tracking using Rank-Score Characteristics. *Information Fusion* 10(2), p. 124-136.

Ma, Fei. (2011). *Seize the VIPs*. China Material Press. p. 22-70.

Rao, Vithala R., Steckl, Joel H. (2008). *Analysis for Strategic Marketing*. Addison Wesley Longman, Inc, p. 44-60.

Smith, Wendell R. (1956). Product Differentiation and Market Segmentation as Alternative Marketing Strategies, *Journal of Marketing*, Vol. 21, No. 1, p. 3-8.

Tibshirani, Robert, Walther, Guenther and Hastie, Trevor (2001). Estimating the number of clusters in a data set via the gap statistic, *J. R. Statist. Soc. B*, 63, Part 2, p. 411-423.

Vinod, H.D., Hsu, D.F. and Tian, Y. (2010). Combinatorial fusion for improving portfolio performance. *Advances in Social Science Research Using R*, Springer, New York, 196, p. 95-105.

Yang, J. M., Chan, Y. F., Shon, T.W., Kristal, B.S. and Hsu, D. F. (2005) Consensus scoring criteria for improving enrichment in virtual screening, *Journal of Chemical Information and Modeling* 45(4), p. 1134-1146.

Yetton, P. W., Johnston, K. D., & Craig, J. F. (2012). Computer-aided architects: a case study of IT and strategic change. *Image*.

DMASSC@USM 2017, <http://usmdigitalmkt.blogspot.com/p/data-set.html>

APPENDIX

Table 1: Number of Clusters and Decision rules: RMSTD=RMS Std Dev, SPRSQ =Semi partial R², RSQ= R²

Method	Numbers of clusters	RMSSTD	Percentage change	SPRSQ	Percentage change	RSQ	Percentage change
Centroid	1	0.9585		0.2043		0	
	2	0.8699	-0.09244	0.4688	1.294665	0.204	
	3	0.5405	-0.37866	0.0751	-0.8398	0.673	2.29902
	4	0.5762	0.06605	0.0813	0.082557	0.748	0.111441
	5	0.466	-0.19125	0.0102	-0.87454	0.829	0.108289
Complete linkage	1	0.9585		0.5725		0	
	2	0.6543	-0.31737	0.1005	-0.82445	0.573	
	3	0.6093	-0.06878	0.1187	0.181095	0.673	0.17452
	4	0.458	-0.24832	0.034	-0.71356	0.792	0.17682
	5	0.4867	0.062664	0.0141	-0.58529	0.826	0.042929
Ward's	1	0.9585		0.5542		0	
	2	0.6475	-0.32446531	0.148	-0.73295	0.554	
	3	0.6321	-0.023783784	0.0804	-0.45676	0.702	0.267148014
	4	0.5446	-0.138427464	0.0566	-0.29602	0.783	0.115384615
	5	0.4135	-0.240727139	0.0223	-0.60601	0.839	0.071519796

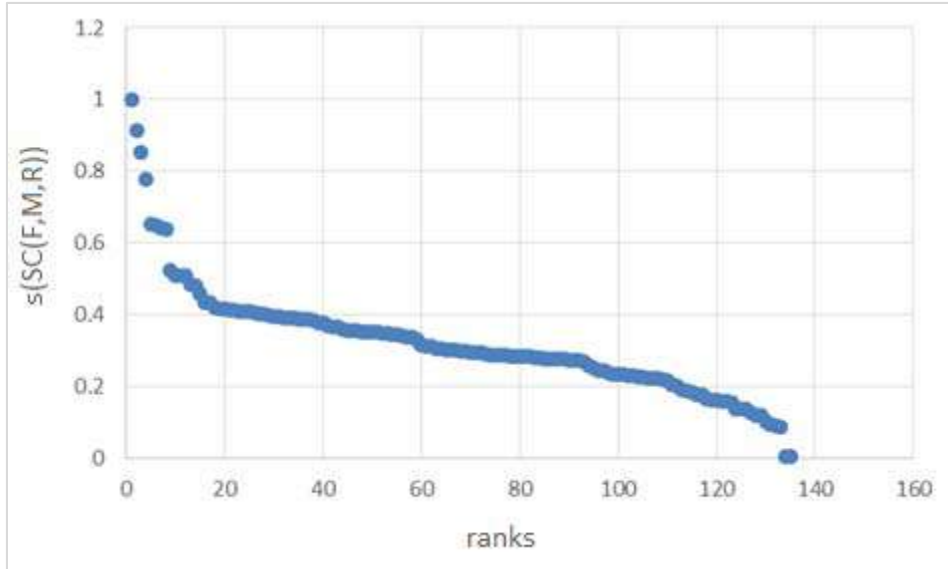

Figure 4: RSC graph of $f(SC(R,F,M))$ with attributes **R, **F**, and **M**:** This RSC graph resulting from Algorithm 1 uses score combination of the three variables for scoring system $s(SC(R,F,M)) = (s_R + s_F + s_M) / 3$.

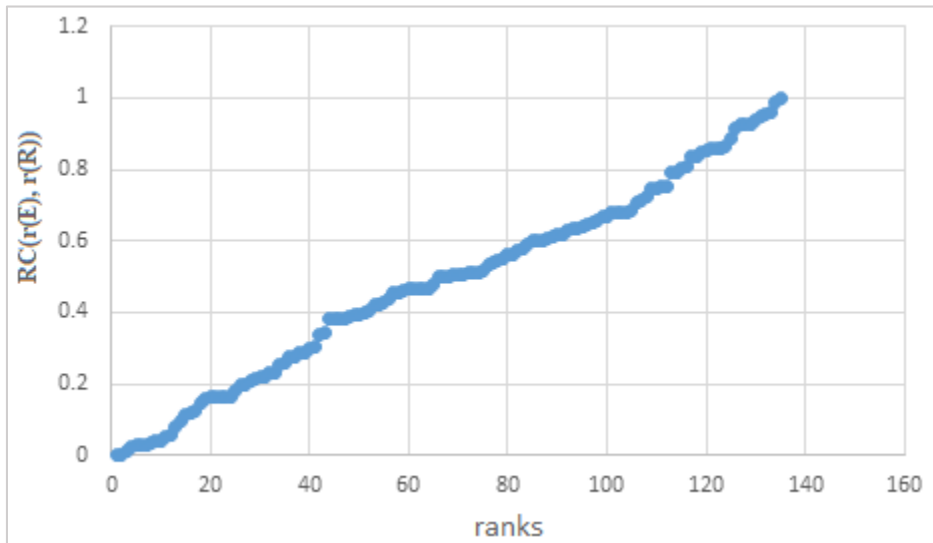

Figure 5: RSC graph of $f(RC(r(E), r(R)))$ where $E=SC(F,M)$ with attributes **R, **F**, and **M**:** This graph features the RSC graph resulting from Algorithm 2 and generated by the rank function r_E , which is the rank combination of the two attributes **F** and **M**, combined with the rank function of **R**, r_R . The direction of the curve is reversed since the rank combination of r_E and r_R inverses the direction of the original scoring systems.

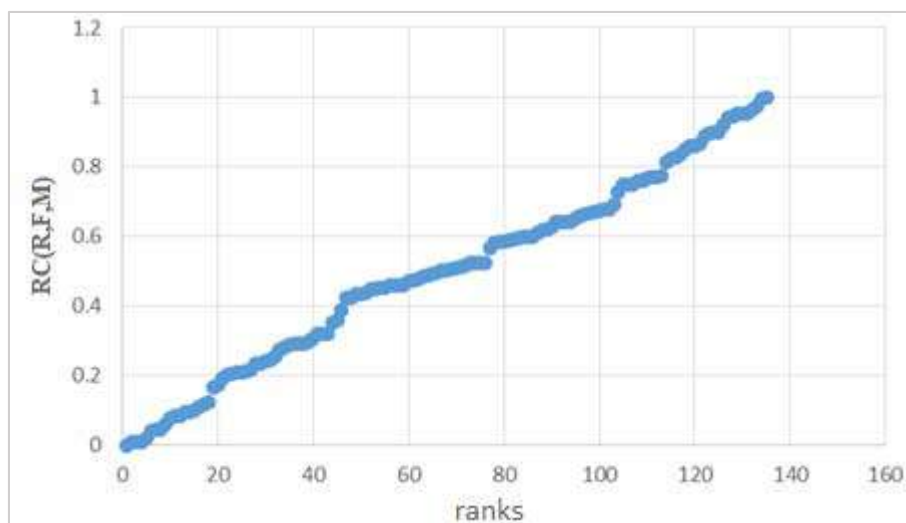

Figure 6: RSC graph of f_G , where $G=RC(R,F,M)$ with attributes R , F , and M : This graph features the RSC graph of f_G , where G is the rank combination of R , F , and M , denoted by $RC(R,F,M)$. The direction of the curve is reversed since the rank combination of r_R , r_F , and r_M inverses the direction of the original scoring systems.

Table 2: Comparison of three CF methods with the Ward's method

Cluster	Jaccard Similarity Index			Customer profile
	$f(SC(R,F,M))$	$f(RC(r(SC(F,M)), r(R)))$	$f(RC(R,F,M))$	
Cluster 1	0.52	0.63	0.7	Low R , F , and M
Cluster 3	0.23	0.45	0.48	Medium R , F , and M
Cluster 2	0.67	0.77	0.8	High R , F , and M

Note: This table contains Jaccard index calculated by comparing classification memberships from the three fusion algorithms and clustering memberships using Ward cluster analysis. Specifically, 1) $f(s(F,M, R))$ represents the rank/score function of the score combination of F , M , and R ; 2) $f(RC(r(SC(F,M)), r(R)))$ represents the rank/score function of the rank combination of $r(E)$ and $r(R)$ where $E=SC(F,M)$; 3) $f(r(F,M,R))$ represents the rank/score function of the rank combinations of F , M and R .

INVESTMENTS IN GROWING ECONOMIES AND INVESTMENT ATTRACTIVENESS OF REGIONS

Oleg N. Zhilkin
RUDN University, Russia

Anna N. Zhilkina
State University of Management, Russia

ABSTRACT

The article is devoted to questions of investments in countries of economic grows. The work deals with the impact of investment on growth in countries with a growing economy. A structure of investment sources, a differentiation in different regions and investment attractiveness of regions is being considered on example of Russia.

Keywords: Impact of Investment on Growth, Investment Attractiveness of Region, Countries with a Growing Economy

INTRODUCTION

Now one of the main problems of economic growth is the search for optimal sources of financing and determination of investment attractiveness of region. The problem exists in all countries of the world and, first of all, in countries with a growing economy. The specificity of growing economies lies in the fact that in this case, investment is accompanied by a high risk. Due to this circumstances, investors pay special attention to the ranking of the region's investment attractiveness. Investment attractiveness in the rating is estimated by two parameters: investment potential and investment risk.

The potential shows how much the region occupies in the domestic market, the risk - what may be the scope of any problems for the investor in the region. The total potential is estimated by nine parameters: labor, financial, production, consumer, institutional, infrastructure, natural resource, tourism and innovation. Integral risk is assessed by six parameters: financial, social, managerial, economic, environmental and criminal.

The contribution of each private risk or potential to the final indicator is evaluated on the basis of a survey of representatives of the expert, investment and banking communities. So, it's interesting to see the actual statement of Russia today.

INVESTMENTS IN COUNTRIES OF ECONOMIC GROWS

Investment statistics on GDP in countries of economic grows demonstrate its high level in the years preceding the maximum growth in these countries (tabl.1)

Tabl.1

Share of investment in GDP in countries of economic grows

Year	Share of investment in GDP, %						
	Japan	South Korea	Singapore	Malaysia	China	Russia	India
1950	-	-	-	-	-	-	10,4
1955	19,4	10,6	-	9,2	-	-	12,3
1960	29,0	11,1	6,5	17,2	-	-	13,3
1965	29,8	14,9	21,3	18,3	-	-	15,8
1970	15,5	25,5	32,5	14,0	-	-	14,8
1975	12,5	28,3	17,3	25,1	-	-	15,3
1980	31,7	12,4	40,8	17,3	28,8	-	12,3
1985	27,7	28,8	32,3	16,2	29,4	-	20,7
1990	32,1	13,2	36,3	15,3	25,0	-	22,9
1995	27,9	14,3	17,4	16,3	12,4	-	14,4
2000	25,2	15,3	22,4	25,3	15,2	16,0	32,7
2005	23,3	28,3	21,3	20,9	15,4	17,0	12,5
2008	20,6	29,3	27,3	20,4	16,2	20,0	14,6
2010	20,5	28,8	25,0	20,3	17,3	19,5	15,7

Source: Compiled by the author according to [1,2]

In general, the ratio of investment in GDP is about 20-30 %. However, in some countries, at certain periods the ratio reached 40% (Singapore, 1980). Also important is the issue of the structure of investment sources, there differentiation in different regions and investment attractiveness of regions. Let's see this on example of Russia.

DISTRIBUTION OF INVESTMENT IN RUSSIA BY SOURCES AND REGIONS

The following nomenclatures of sources and their groups are distinguished in Rosstat statistical data [3]:

- Total,
- own funds,
- profit remaining in the provision of the organization (accumulation fund),
- depreciation,
- involved funds,
- loans from banks,
- loans from foreign banks,
- borrowed funds of other organizations,
- budget resources,
- budgetary funds from the federal budget,
- budgetary funds from the budgets of the constituent entities of the Russian Federation,
- means of the local budget,
- means of off-budget funds,
- other,
- means of higher organizations,

- funds from the equity participation in construction (population funds),
- funds, from the issue of corporate bonds,
- funds from the issue of shares,
- investments from abroad.

As of 2015, we see the following picture of investments in fixed assets by sources of financing:

- total 10277159.1 million rubles.,
- own funds 5256513.3 million rubles,
- attracted funds of 5,020,645.8 million rubles,
- loans to banks 805293.1 million rubles.,
- loans of foreign banks 197493 million rubles.,
- borrowed funds of other organizations 585424.4 million rubles.,
- budgetary funds 1699431.7 million rubles.,
- budgetary funds from the federal budget 1000328.7 million rubles.,
- budgetary funds from the budgets of the subjects of the Russian Federation 577923 million rubles,
- means of the local budget 121180,1 million rubles.,
- funds of off-budget funds 26784.3 million rubles,
- other 1500973.8 million rubles.
- funds of higher organizations 1074573.9 million rubles,
- funds received from equity participation in construction (organizations and population) 307240.3 million rubles,
- funds received from equity participation in construction (population funds) 246412.2 million rubles,
- funds from the issue of corporate bonds 160458.1 million rubles.,
- funds from the issue of shares 53415.5 million rubles.,
- investments from abroad 95498.2 million rubles.

Thus, the value of own funds (5256513.3 million rubles.) Practically equal to zero (5020645.8 million rubles.). Despite the fact that in 2010 the volume of funds aimed at developing the market amounted to 1699431.7 million rubles, mainly from the federal budget (1,000328.7 million rubles.). Also, a significant place is taken by the funds of "centralized" funds of organizations (1074573.9 million rubles).

The share of attracting investments through securities is very small. And here we see a certain caution of savings investors - the funds from the issue of corporate bonds amounted to 160458.1 million rubles. In comparison with the funds from the issue of shares in 53415.5 million rubles., Ie. 3 times less. Perhaps this is due to fears of the owners of the company that control it.

From an economic point of view, cash, albeit with less income, but with less risk.

Of course, such behavioral preferences of potential investors (including banking ones) do not favor the creation of a favorable investment climate for investments in the future.

THE OPINION OF FOREIGN INVESTORS ON THE INVESTMENT CLIMATE IN RUSSIA.

Due to the fact that Russia is a country of increased attention from foreign investors, many reputable companies conduct regular monitoring of Russia's investment climate. So, for example, according to the estimates of the British audit and consulting company Ernst & Young Global Limited (EY), the investment climate in Russia is now called controversial.

In order to present the current situation, a survey was conducted of representatives of foreign companies - members of the Foreign Investment Advisory Council in Russia.

In 2014 there were several events that had a significant impact on the investment climate in Russia and the mood of foreign investors working in the country. The most important of these were the introduction of sanctions against Russia and a sharp drop in oil prices, which led to a significant deterioration in the macroeconomic situation in Russia, rising inflation, the unstable ruble, difficulties in attracting financing and high interest rates, restrictions on foreign trade and difficulties in Work in the industry markets.

The complication of international relations and the deterioration of the macroeconomic situation in Russia in an explicit form affected the mood of foreign investors: in 2014, the volume of foreign direct investment in the Russian economy fell by 70% - to \$ 21 billion, reaching a minimum level since 2006. In the second half of 2014, the Bank of Russia for the first time since 2005 recorded a net outflow of foreign direct investment. Experts associated with the activities of foreign companies, noted in 2014-2015, the reduction of investment projects initiated and implemented by foreign investors in Russia.

The results of the research showed that although investors investing in the real sector view the current situation as unfavorable, they do not plan to reduce their presence in the country. Noting the positive, including the "Road maps" of the national business initiative to improve the investment climate in the Russian Federation, companies see the potential of the Russian economy and are inclined to increase the volume of investments in the coming years.

Assessing the current economic situation, foreign companies called it unfavorable - this was stated by 92% of respondents. Speaking about the dynamics, 90% noted that the situation in the Russian economy has deteriorated in recent years, and only 5% noted that some positive changes have taken place recently. Along with the worsening of the economic situation, the conditions for doing business in Russia are insignificant for most participants (59%) or significantly worsened (15%). 42% of respondents believe that Russia's attractiveness for foreign companies planning to start or expand commercial activity will decrease in the next two years, and only 17% believe that the attractiveness will increase. Despite this, a significant number of companies state plans to expand the geography of their presence in the next two years (39%) or maintain their presence in Russia (31%).

Plans for doing business in Russia are largely related to the localization of production and the involvement of more Russian suppliers. Answering the question about plans for the use of Russian components and raw materials, 58% of respondents expressed their readiness to increase the share of these products in their production.

Speaking about the prospects of attractiveness of the Russian market, foreign investors are wary of discussions on policy issues in the field of import substitution. Expressing their readiness to continue localization of production on the territory of the country, the companies express their fears that the main actions in this sphere will be reduced to restricting competition and hindering the access of products of companies with foreign capital to the Russian market.

Assessing the prospects, respondents are mostly optimistic about the future: 53% of the companies surveyed expect a significant or moderate growth in their industry in the next two years. A quarter of study participants, on the contrary, expect a negative development of the situation. According to investors, the most attractive sectors in Russia in the next two years will be the electric power industry (44% of answers), the pharmaceutical industry (39%) and telecommunications services (28%).

Foreign investors pay special attention to the situation in the regions. Foreign companies operating in Russia note that the investment climate in the regions has improved significantly in recent years. A major role in

this process is played by the implementation of the Regional Investment Standard developed by the Agency for Strategic Initiatives (the document defines the requirements for government authorities to work with investors), road maps for improving the investment climate, and a set of performance indicators in this area included in the evaluation of governors. The second factor that increases the interest of regions in foreign investment is the strengthening of regional competition for investment against the backdrop of worsening macroeconomic situation. These factors have led to the fact that the regional authorities began to pay more attention to both the aspects related to the investment climate and investor relations. More than half of the respondents believe that the executive authorities in the regions are effectively working to improve the investment climate

CONCLUSION

Investing, we will clarify, we correctly invest in fixed assets, we invest in our future. By building the potential of a separate industrial enterprise, we are building up the potential of our country. Unfortunately, there are no clear solutions yet to be solved.

REFERENCES

Data of Investment Company EuroFinance. – mirkin.ru.

Data of Russia Investment. – ray-idaho.ru.

Investments in fixed assets by sources of financing //Rosstat. - <http://www/gks.ru>.