

# **Evaporative Cooler self salt clean**

**Dr. Mohammed Ali Bahobail**  
Department of Architecture and building sciences  
College of Architecture and Planning  
King Saud University

## **Abstract:**

Evaporative coolers are popular in the dry climate region, as an energy efficient means for space cooling.

It consists of a large metal box with a big fan and three water wetted pad doors. The wetted pads are usually made of cedar shavings or cellulose, which kept damp by a water circulation pump.

The fan drags the hot and dry outside air through the wetted pads cooling the air due to evaporates water molecules from the pads. The fan then blows the cooled air through an outlet vent.

Evaporative coolers are relatively economical, less expensive to install and to operate. They are consuming less electricity than a refrigerated unit, and they do not need an expert to maintain. In addition, evaporative coolers provide the building with a fresh humid air.

However, evaporative coolers have some disadvantages; one of them is the deposited salt. Water usually has a high percentage of mineral. The evaporative mechanism will leave mineral deposits on the pads and interior of the cooler. This cumulative mineral will close the porous of the wetted pads and damage them and will participate to corrosion of the cooler frame.

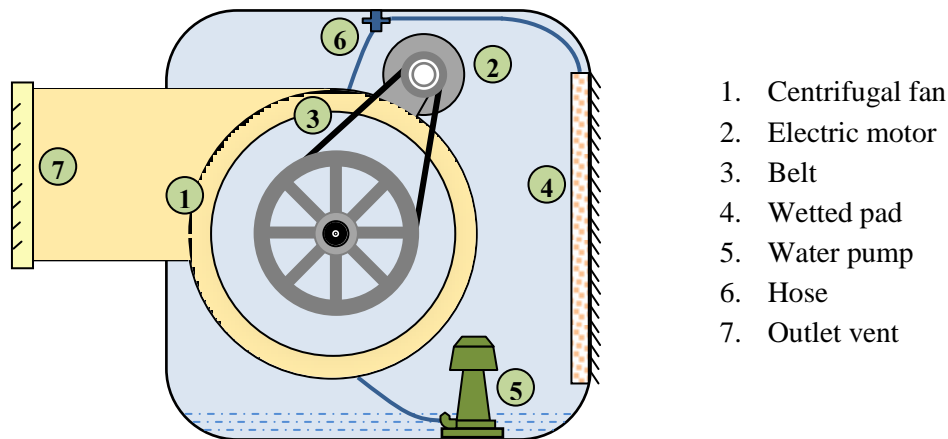
This study aims to develop the evaporative cooler efficiency by utilizing solar water still. The main objective of this proposal technique is to minimize the quantity of the cumulative salt by removing part of it.

## Introduction:

Evaporative coolers (also called swamp coolers, desert coolers, and wet air coolers) are devices that cool air through evaporation of water. They are especially well suited for hot dry region. The amount of heat transfer depends on the evaporation rate, which depends on the humidity of the air and its temperature.

The normal design, therefore, is a metal box with three vented sides. Each side has a removable wetted pad door. Usually, evaporative cooler pads made of excelsior (wood wool) inside a bag of net. Recently, more modern materials, such as plastics and melamine paper, are starting to be used as cooler-pad media. The thickness of wetted pad plays a very significant role in cooling efficiency, the more pad thickness the longer air contact.

The cooled air is delivered by a centrifugal fan which is connected to an electric motor through pulleys and belt. Water is circulated by a small water pump to wet the evaporative cooling pads (figure 1).



**Figure (1): Evaporative cooler**

The evaporative coolers have several advantages; they save cooling energy comparing to a refrigerated systems. The fan and water pump are the only parts consuming power vs. compressors, pumps, and blowers in the other systems.

They are environmentally friendly; provide the building with a fresh humid air, and low installation and operation cost. The installation cost is about half that of central refrigerated air conditioning [6]. In addition, They do not need a specialist for maintenance, the only two electrical parts are a

electric fan motor and a small water pump, which can be repaired or changed by the home owner at low cost .

These advantages, made those techniques to be commonly used in Gulf countries

However, evaporative cooling consumes a huge amount of water to wet the pads. The Evaporative mechanism will leave salt deposits on the pads and interior surfaces of the cooler (figure 2, 3). This cumulative salt will block the air flow by closing the porous of the wetted pads and damage them. Besides that, this salt will contribute to corrosion of the cooler body.



**Figure (2): The affect of the cumulated salt on the evaporative cooler (outside the cooler)**



**Figure (3): The affect of the cumulated salt on the evaporative cooler (inside the cooler)**

### **Previous works:**

There are several attempts to improve the evaporative coolers performance and their efficiency, and to achieve the proper wetted pad media.

The basic principle of the evaporative cooling processes for human thermal comfort was studied, along with the mathematical development of the thermal exchanges [2].

In another study, a thermo economic analysis method based on first and second law of thermodynamic was applied to an evaporative cooling system coupled to an adsorption dehumidifier [3].

On the other hand, a cross-flow direct evaporative cooler was investigated, in which the wet honeycomb paper constitute the packing material and the results indicate that the performance can be improved by optimizing some operation parameters [5].

The performance characteristics of a pad evaporative cooling system in a broiler house in a Mediterranean climate, was investigated. The results indicated, that evaporative cooling systems can be recommended for sustainable poultry production in the Mediterranean region [4].

Three different natural fibers were examined as wetted medias. The study investigated their performance against the salt deposition. These three fibers were date palm fibers (stem), jute and luffa gourd. A commercial wetted pad was used to be a reference. The results came up with the jute has the least salt deposition followed by palm and luffa gourd fibers. While the commercial type has the highest salt deposition [1] .

However, the most frequently deteriorating parts are the wetted pads which play very essential role in the cooling process. The most important factors affect the efficiency of the wetted pad are the type of materials used in the pad, its thickness, surface area and the size of the perforation and the flow rate of air passing through the pad [7].

In fact, the majority of the commercial wetted pads are wood based, where the salt deposition and mold forming usually clog their surfaces, declining the flow rate of air and decrease the performance of the evaporative cooler [1].

Due to the abhorrent implications of salt deposition, the salt accumulation needs to be controlled and minimized to maintain the wetted bad and the body of the cooler from damage, which will be discussed on this study.

### **Objective of the study:**

The study aims to develop and enhance the efficiency of evaporative cooler performance by utilizing solar still, and to outline the impact of using such systems on the wetted pads media.

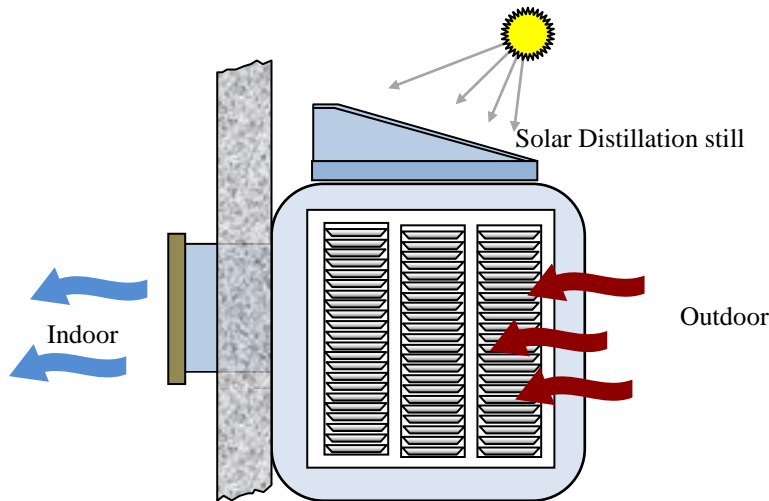
### **Significance of the study:**

The importance of the study stems from the negative effect that salt deposition do in the evaporative cooling system. The effect of minimizing salt deposition is not restricted to the cooler performance, but it will save money by increasing the lifetime of the wetted pads and the metal enclosure, and reduce the numbers of maintenance.

By adapting solar water still, evaporative cooler will have ability to minimize the salt buildup with no extra cost in electricity. The still is totally depend on solar radiation which is available most of the day and free of charge.

**The proposal system:**

The solar still and their accessories will be incorporated into the ordinary evaporative cooler, which can be installed over the roof of the cooler (figure 4).



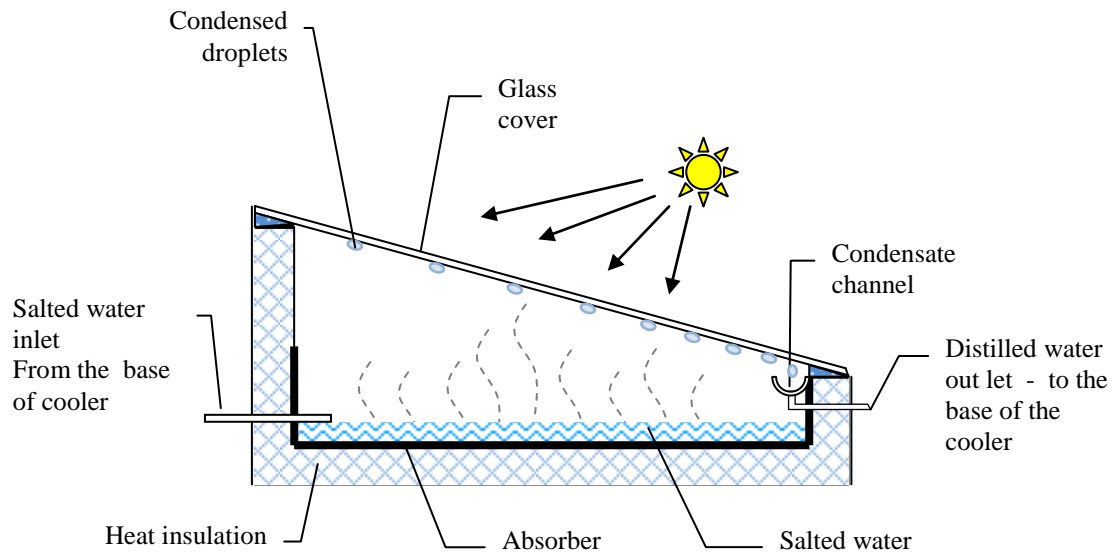
**Figure (4): Evaporative cooler with solar distillation still**

The idea of this proposal is concentrated on the solar distillation still (figure 5). The mechanism of solar still consists of two steps, evaporation and condensation. The sun's radiation heats water to the level of evaporation. As soon as water evaporates, water vapor is condensed on the inner surface of the glass cover for collection. [8].

The task of the proposed solar still is to draw the salty water from the base of the cooler and desalinate it by evaporating the water. The water vapor will be condensate and return back to the cooler's base. This operation removes impurities such as salts, dust particles and minerals as well as eliminates microbiological organisms. These wastes will remain on the base of the still and they can be removed easily from it at the time of changing the wetted pads.

The solar distillation still consists of a basin, to contain the salted water, and transparent glass cover to let solar radiation into the still. The solar radiation will be absorbed by the base's surfaces, increasing the basin temperature. The cover also prevents the escape of moisture from the still and provides a cool surface for the condensation of water vapor. The cover is sloped on one side so that

the water vapor, which condenses on its bottom surfaces, drips into collector. The collector “trough” is sloped so that the collected water flows out of the still. The still should be waterproofed and air tight except for the inlet and outlet. The base of the still should be blackened on its interior surface to allow maximum absorption of solar radiation. In addition, the still must be insulated on all sides except for the top to prevent any heat loss.



(Figure 5): Solar Distillation still

The amount of distilled water can be estimated by using the following formula [8].:

$$Q = \frac{A \times G \times E}{2260} \dots\dots\dots (1)$$

Where:

Q – total output-distilled water per day (liters/day)

A – total distill area (m<sup>2</sup>)

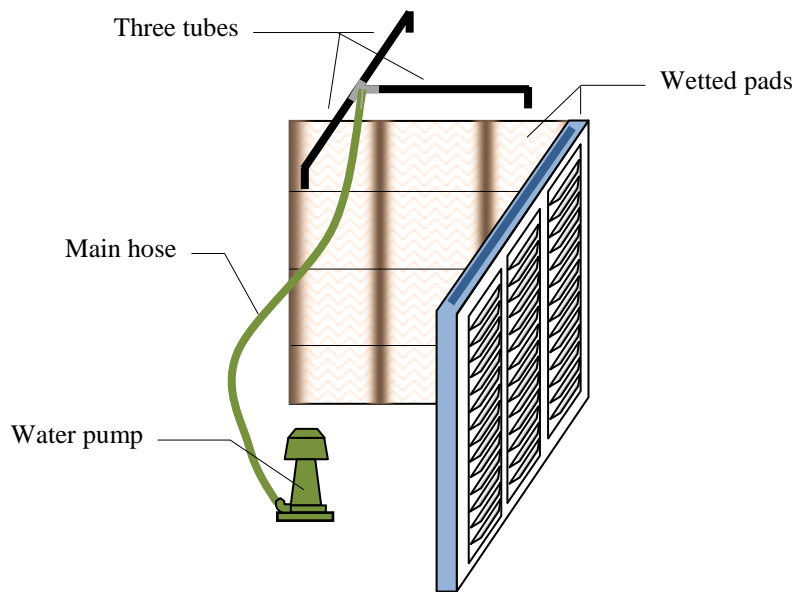
G – daily solar radiation in KJ/m<sup>2</sup>-day ( data varies from time to time and from region to region.

The data can be obtained from the National Weather Service)

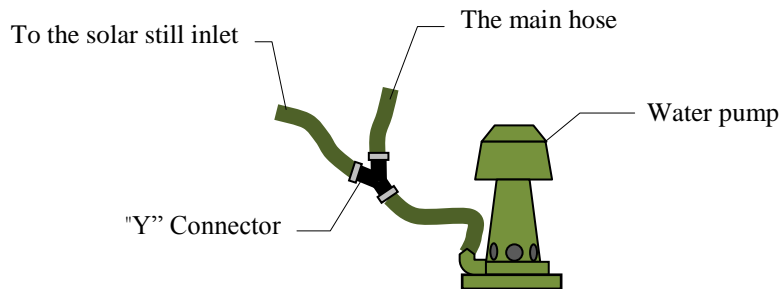
E – efficiency of solar still in decimal.

**Incorporate the solar still with evaporative cooler:**

As mentioned above, the solar still will be located over the roof of the cooler. Two hoses connect the still with the cooler. The first hose connects the water pump of the cooler with the salted water inlet of the still. In ordinary case, water pump circulates water through the cooler system. It pumps the water from the base of the cooler to the wetted pads through main hose ended with three tubes (figure 6). In our case, a “Y” connector will be installed between the water pump and the main hose. The Y connector gives two outlets; one outlet is used to connect the pump with the main hose and second outlet used to connect the pump with the hose of the salted water inlet of the still (figure 7).



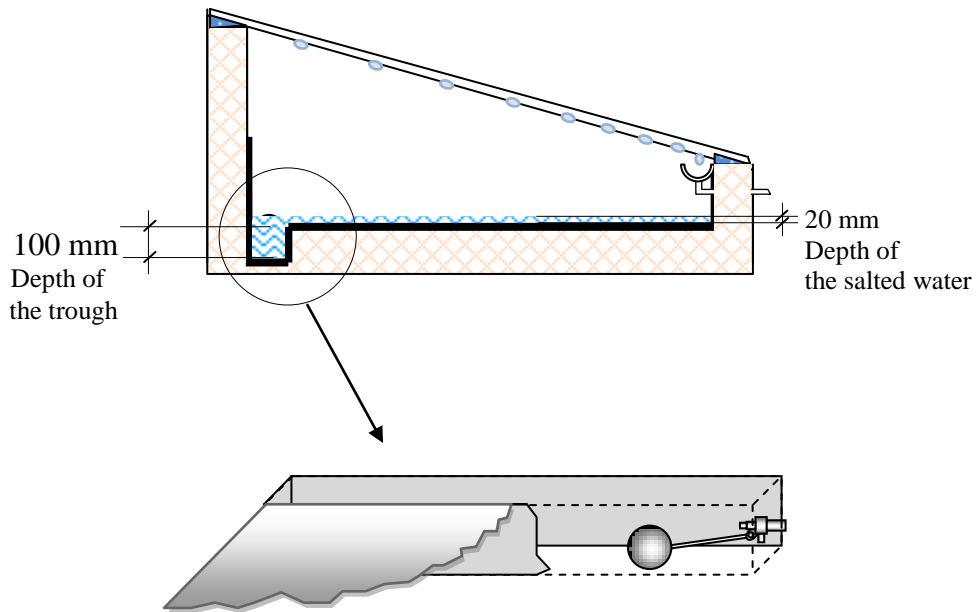
**Figure (6): Water pump connection (ordinary case)**



**Figure (7): Water pump connection (after modification)**

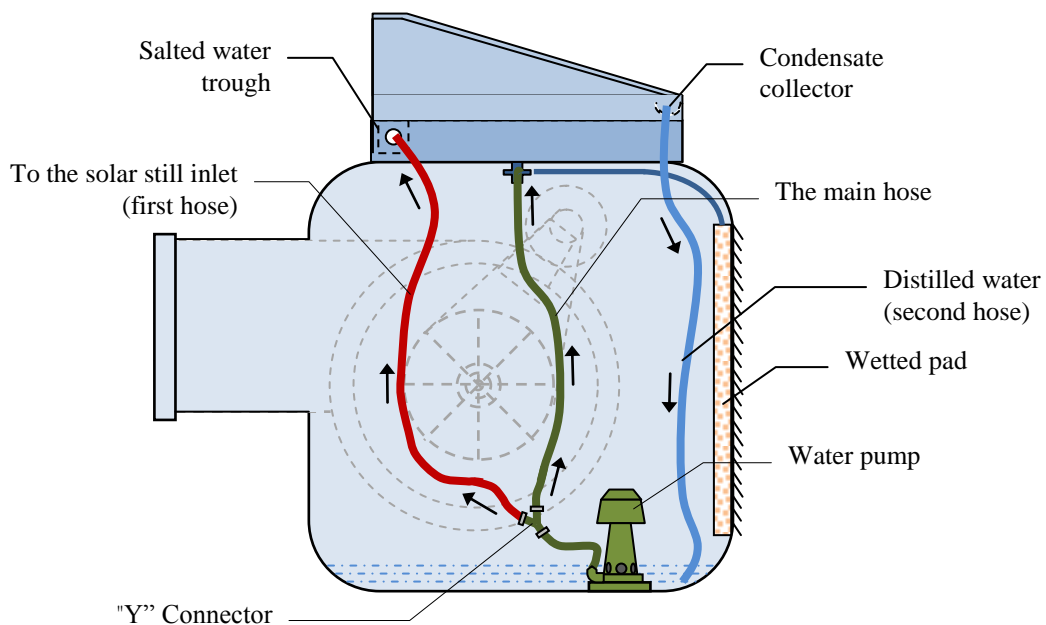
The saline water in the still should not be too deep. The depth needs to be maintained at around 20mm. Therefore, the still’s base is redesign to include a small trough (figure 8). The trough is

about 100mm depth and fitted with the salted water inlet. The salted water inlet ends with a floating valve to maintain the water depth at 20 mm and to prevent it from flooding.



**Figure (8): The salted water trough with floating valve**

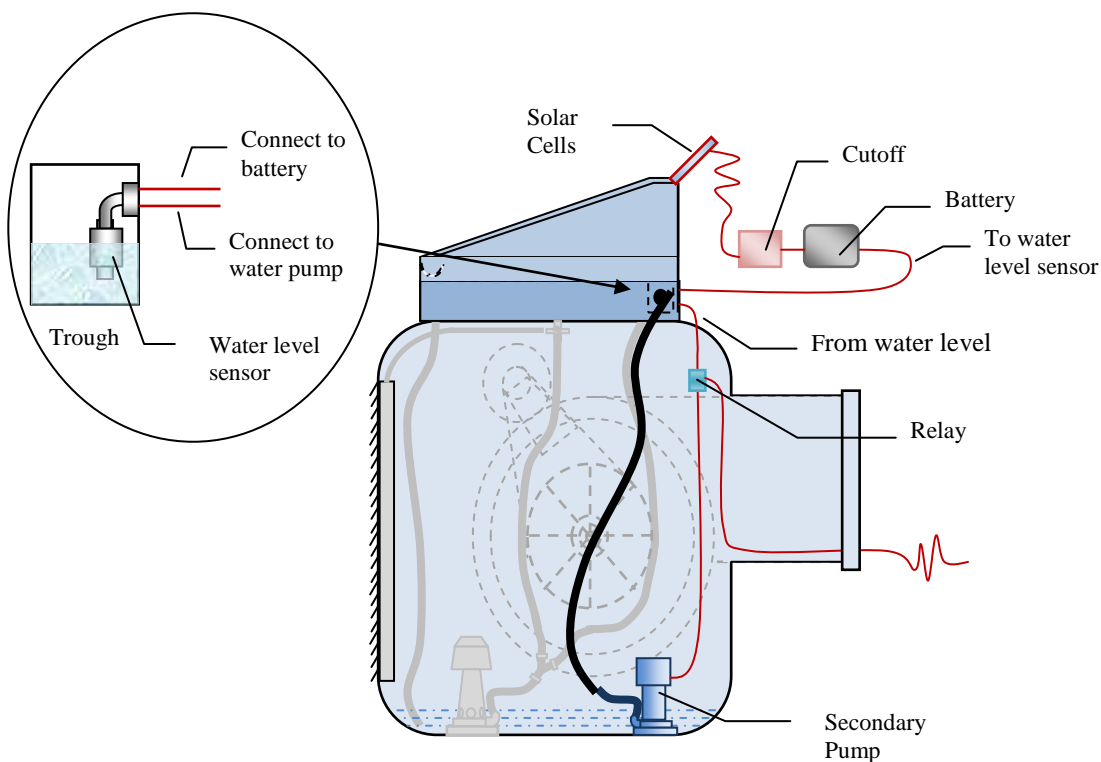
The second hose connects distilled water out let with the base of the cooler. The purpose of this hose is to return the distilled water back to the base of the cooler. Figure (9) shows the complete system.



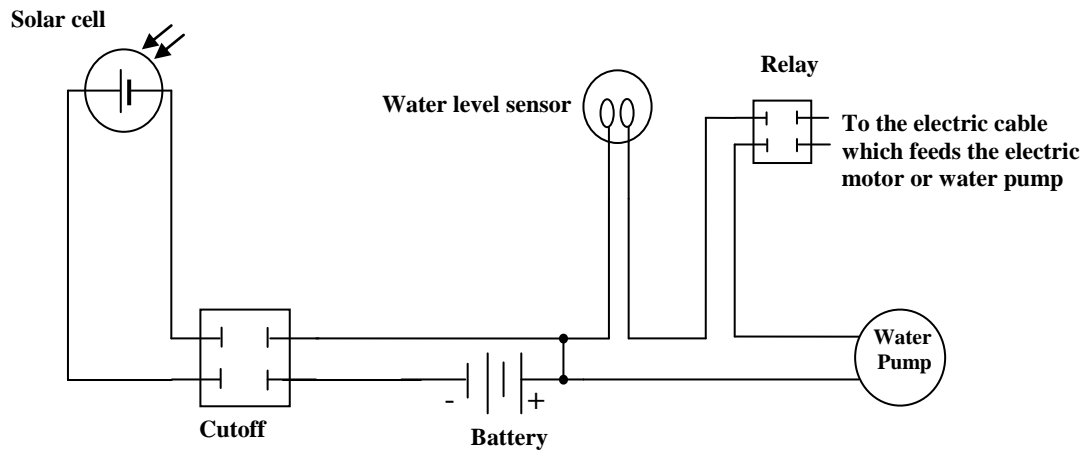


**Figure (9): The complete system**

To keep the still working on while the cooler system off, the still is provided with solar cells and a small secondary pump (12 volt). Figure 10 shows the strip of solar cells located on the upper top side of the still. The solar cells will receive solar radiation and convert it to an electric energy, which will be stored in a battery during the cooler system on. The trough is provided with an electric “water level” sensor which turns the secondary water pump on when the water level is below the minimum level and the cooler system is off. The solar cells system, also, includes a relay switch and a cutoff device. The relay switch is connected to the electric cable which feeds the electric motor or water pump. When the cooler is on, the relay will disconnect the battery from the secondary pump, and vice versa. The task of cutoff device is to keep battery from damage by preventing battery from over charge (figure 11 shows the circuit diagram of the system).



**Figure (10): the solar cells system**



**Figure (11): Circuit diagram of the system**

**Process description:**

The complete system consists of two parts; the solar still and the evaporative cooler.

When the system is turned on, the water pump starts pumping the water to the wetted pads and to the base of the solar still through “Y” connector. When the salted water, in the solar still base, reaches the maximum level, the floating valve stops water flow from getting in. The water pump continues running to keep the wetted pad saturated with water.

The glass cover of the still lets the solar radiation to pass into the still, and absorbed by the blackened base. The temperature of the base rises up and the salted water begins to evaporate. The moisture content of the air, inside the still, increases. The base also radiates energy back to the glass cover in the form of a long wave (infra-red region), but this radiation has no ability to pass through the glass and reflected back into the still. This operation traps the solar energy inside the still (the greenhouse effects). The heated water vapor evaporates from the basin and condenses on the inner surfaces of the glass cover, which is at a lower temperature because it is in contact with the ambient air. In this process, the salts and microbes and other particles that were in the cooler water are left behind and accumulated in the bottom of the base.

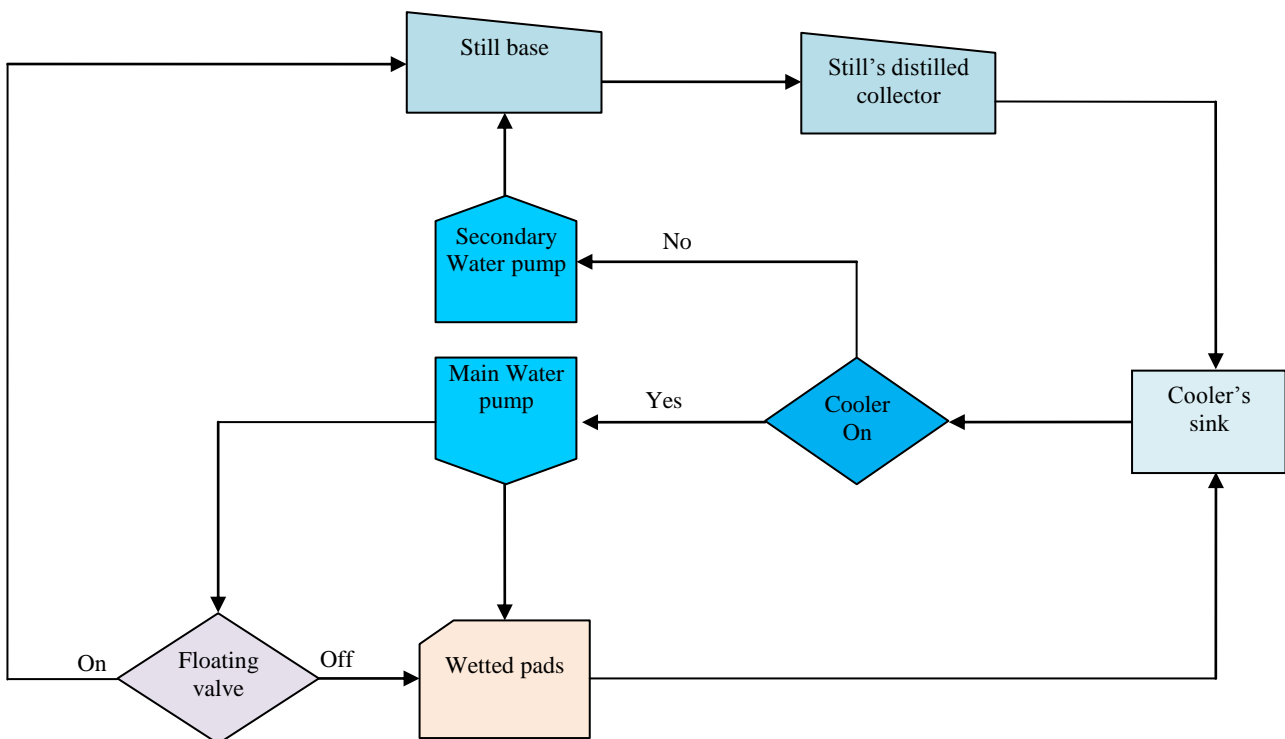
Condensed water drips down the inclined glass cover to the collector “trough”, and then, returns back to the sink of the cooler.

When the level of salted water goes down, due to the evaporation mechanism, the floating valve, turns on, lets the water running in to recharge the base again with water.

The operation continues as long as the cooler “on”, the salted water moves from the sink of the cooler to the solar still and return back as distilled water. After sundown, the still will continue to produce distillate until the water temperature cools down.

When the cooler is turned off, the relay of the solar cells system goes on and connects the secondary water pump with the solar system. The secondary water pump pumps the salted water to the trough until the certain level where the water level sensor disconnects the power from the pump.

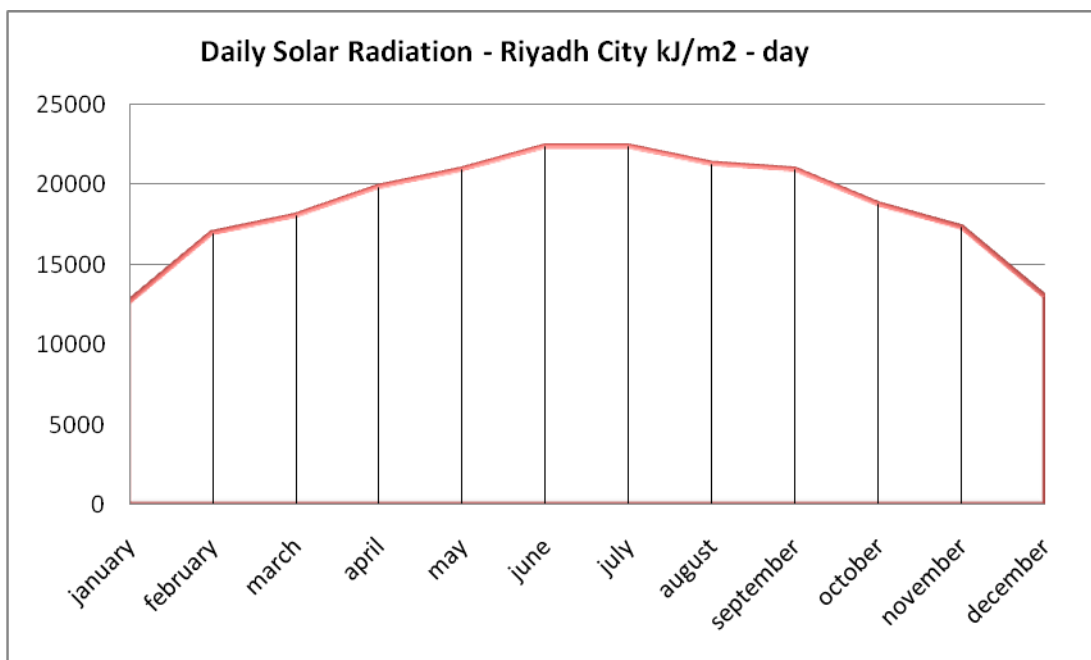
The system keeps on producing distillate water until the salted water in its base dries or its temperature goes down, or the battery run out from energy. Figure 11, shows the diagram of water flow process.



**Figure (11): Water flow process**

**Predicted System output and Efficiency (Riyadh city as an example):**

The size of the still is based on the roof area of the evaporative cooler, where the still is placed. The areas of the evaporative coolers are varied according to their power size. According to the sizes of the available cooler in the Saudi market, table1 shows the distilled water output which can be calculated based on the daily solar radiation in Riyadh city during the summer session (Figure 12) by using formula (1).



**Figure (12): daily solar radiation in Riyadh city**

**Table (1): Total output-distilled water per day (liter/day)**

				Total output-distilled water per day (liter/day) efficiency =60%					
size (hp)	L (m)	W (m)	Area m2	May (20880 KJ/m2-day)	June (22320 KJ/m2-day)	July (22320 KJ/m2-day)	August (21240 KJ/m2-day)	September (20880 KJ/m2-day)	October (18720 KJ/m2-day)
1/6	0.56	0.65	0.364	2.017784071	2.156941593	2.156941593	2.052573451	2.017784071	1.809047788
1/4	0.714	0.714	0.509796	2.825984198	3.02087966	3.02087966	2.874708064	2.825984198	2.533641005
1/3	0.86	0.86	0.7396	4.09987115	4.382620885	4.382620885	4.170558584	4.09987115	3.675746549
1/2	0.87	0.86	0.7482	4.147544071	4.433581593	4.433581593	4.219053451	4.147544071	3.718487788
3/4	0.9	1.41	1.269	7.034527434	7.519667257	7.519667257	7.155812389	7.034527434	6.306817699
1	0.9	1.59	1.431	7.932552212	8.479624779	8.479624779	8.069320354	7.932552212	7.111943363
1 1/2	1.04	1.55	1.612	8.935900885	9.552169912	9.552169912	9.089968142	8.935900885	8.011497345
2	1.04	1.55	1.612	8.935900885	9.552169912	9.552169912	9.089968142	8.935900885	8.011497345
3	1.04	2	2.08	11.53019469	12.32538053	12.32538053	11.72899115	11.53019469	10.33741593
4	1.04	2	2.08	11.53019469	12.32538053	12.32538053	11.72899115	11.53019469	10.33741593

In table 1, the first four columns from left represent the coolers specification, where the fourth column indicates the roof area, in square meters, of the coolers. The rest of the columns (from column five to column ten) indicate the total output-distilled water per day (liter/day) during the summer session, from May up to October.

The table 1 shows that the distilled water output is ranged between 2 to 12.3 liters per day, according to the size of the cooler, where the still efficiency is assumed to be 60%. This indicates a good potential and it should be noted that withdraw a certain liters of salted water from the cooler base will reduce the salt degree in its water, and return it back as a distilled water will reduce it more again. In addition, this output can be increased by increasing the degree of still efficiency.

In addition, figure13 indicates that the amount of distilled water output is proportional with the still area and with solar radiation. Thus can be seen in June and July where the solar radiation is high comparing to the other months. From other side, the output increases when we move from the small size coolers to the bigger one.

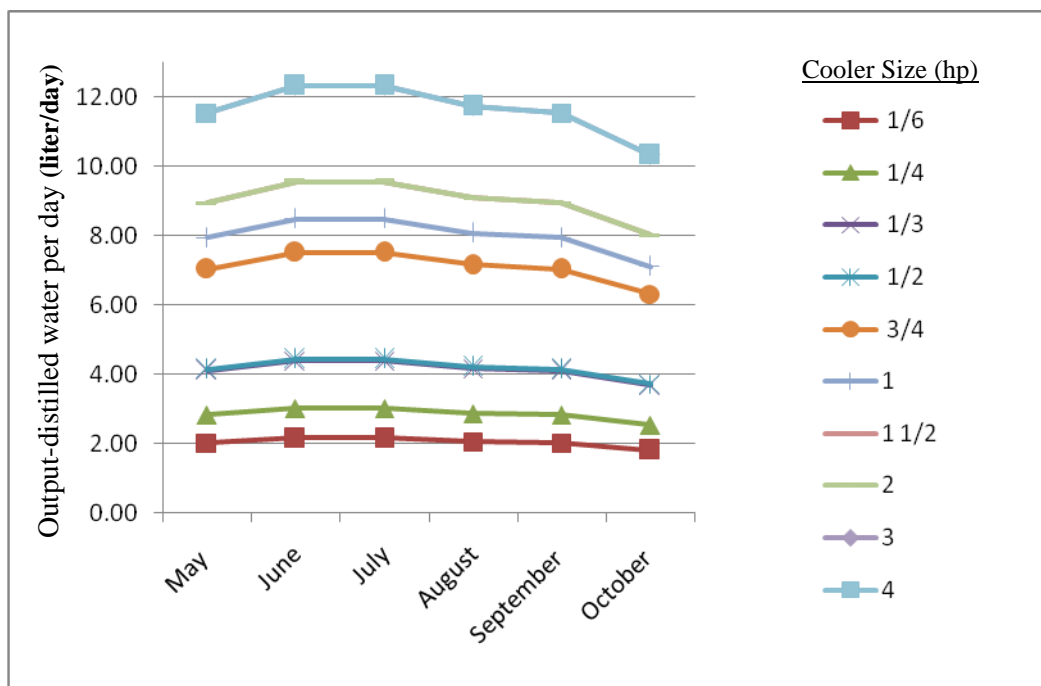


Figure (13): Total output-distilled water per day (liter/day)

## Conclusion:

A solar distillation still is incorporated with a centennial evaporative cooler. The solar still is designed to receive salted water from the cooler and return it back as distilled water. It is, also, provided with a solar cells system to save energy and to keep the still working on while the cooler is off.

Evaporative cooler does not need a major modification to be incorporated with the solar still; it needs only a minor adjustment which does not require an expert to do it.

The proposed system aims to eliminate the sediment, (salt, dust, mold, microbes or any other particles) of the evaporative cooler, by accumulating them in the base of the still, which can be cleaned and removed easily.

By eliminate the sediment, the life time of the centrifugal fan, electric motor, water pump, wetted pads and other supplements of the system will be extended due to reduction of the corrosion's causes.

Finally, by adapting this system, eliminating the cooler's sediment is not restricted to economical aspects only, but it extends to cover health aspects, and create healthy environment.

## References:

1. Al-Sulaiman, F., *Evaluation of the Performance of Local Fibers in Evaporative Cooling*, Engineering conversion and management, Elsevier, Amsterdam, 2002. P. 2267-2273.
2. Camargo, J., Ebinuma, C., Cardoso, S., *A mathematical model for direct evaporative cooling air conditioning system*, Thermal Engineering , Brazil 4 (2003) 30-40.
3. Camargo, J., Ebinuma, C., Silveira, J., *Thermoeconomic analysis of an evaporative desiccant air conditioning system*, Applied thermal engineering, Elsevier, Amsterdam, 23 ( 2003) p. 1537-2549.
4. Dagtekin, M., Karaca, C., Yildiz, Y., *Performance characteristics of a pad evaporative cooling system in a broiler house in a Mediterranean climate*, Biosystems engineering, 103 (2009) p. 100-104.
5. Dai, Y., Sumathy, K., *Theoretical study on a cross-flow direct evaporative cooler using honeycomb paper as packing material*, Applied thermal engineering, Elsevier, Amsterdam, 2002. P. 1417-1430.
6. John Krigger and Chris Dorsi (2004). *Residential Energy: Cost Savings and Comfort for Existing Buildings*, (4th ed.). Saturn Resource Management. p. 207.
7. Smmons, J. D, Lott, B. D., *Evaporative cooling performance resulting from changes in water temperature*. Applied Engineering in agriculture, 12(4), (1996) p. 497-500.
8. Solanki, C. S. "Renewable Energy Technologies", Prentice Hall of India, New Delhi (2008).