

Current and Future Research Trends in Substrate Integrated Waveguide Technology

Maurizio BOZZI¹, Luca PERREGRINI¹, Ke WU², Paolo ARCIONI¹

¹ Department of Electronics, University of Pavia, Pavia, Italy

² Poly-Grames Research Center, Department of Electrical Engineering, École Polytechnique de Montréal, Canada

maurizio.bozzi@unipv.it, luca.perregrini@unipv.it, ke.wu@polymtl.ca, paolo.arcioni@unipv.it

Abstract. *Substrate Integrated Waveguide (SIW) technology is the most promising candidate for the implementation of millimeter-wave (mm-wave) integrated circuits and systems for the next decade. Based on planar dielectric substrates with top and bottom metal layers perforated with metalized holes, SIW structures offer a compact, low loss, flexible, and cost-effective solution for integrating active circuits, passive components and radiating elements on the same substrate. This paper presents an overview of the current status and future trends of academic and industrial research on SIW technology. The historical development of SIW components and circuits is briefly outlined, and the current research topics are discussed: they include the development of numerical techniques for the modeling and design of SIW components, the investigation of novel compact and broadband interconnects, the determination of design solutions for loss minimization. Future research trends are also discussed: they mainly aim at the implementation of SIW components at higher frequency (60-350 GHz) and the integration of complete Systems-on-Substrate (SoS).*

Keywords

Millimeter-waves, passive waveguide components, System-on-Substrate (SoS), Substrate Integrated Waveguide (SIW), Substrate Integrated Circuits (SICs).

1. Introduction

The deployment of millimeter-wave (mm-wave) integration technologies is critical for the evolution of wireless systems and applied electromagnetics in the next few years. In fact, a variety of applications has been recently proposed in the frequency range between 60 GHz and 94 GHz: they include wireless networks [1], automotive radars [2], imaging sensors [3], and biomedical devices [4]. In most of these systems, the success mainly depends on the availability of a cost-effective technology, suitable to the mass-production of wireless systems. It is expected that high density integration techniques, combined with a low-cost

fabrication process, should offer the widespread solution for mm-wave commercial applications.

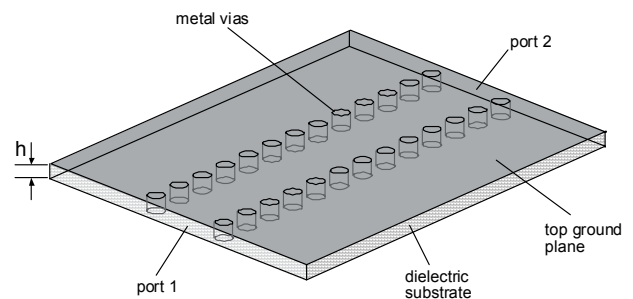

Fig. 1. Substrate integrated waveguide.

A promising candidate for developing this platform is the substrate integrated waveguide (SIW) technology [5]-[9]. SIW are integrated waveguide-like structures fabricated by using two periodic rows of metallic vias or slots connecting the top and bottom ground planes of a dielectric substrate (Fig. 1). The SIW scheme belongs to the family of substrate integrated circuits that include other substrate integrated structures such as substrate integrated image guides and substrate integrated non-radiative dielectric (SINRD) guides. In fact, any non-planar waveguiding structure including classical rectangular waveguide and coaxial lines can be synthesized into planar form, which can be seamlessly integrated with conventional printed planar circuits such as microstrip lines and coplanar waveguide. SIW components, which have been the most popular due to their easy design and fabrication, combine most of the advantages of planar printed circuits and metallic waveguides. Similar to microstrip and coplanar lines, SIW components are compact, light, easy to fabricate, flexible, and cost effective. SIW structures also preserve most of the advantages of conventional metallic waveguides, namely, complete shielding, low loss, high quality-factor and high power-handling capability.

One of the major advantages of SIW technology is the possibility to fabricate a complete circuit in planar form (including planar circuitry, transitions, rectangular waveguides, active components and antennas), using a standard printed circuit board or other planar processing techniques. Moreover, there is the possibility to mount one or more

chip-sets on the same substrate. There is no need of transitions between elements fabricated with different technologies, thus reducing losses and parasitics. In this way, the concept of System-in-Package (SiP), widely adopted in the design of RF circuits, can be extended to the System-on-Substrate (SoS) [10], [11]. SoS represents the ideal platform for developing cost-effective, easy-to-fabricate and high-performance mm-wave systems.

A significant effort has been devoted to the research and development of SIW technology in the last few years: this widespread research activity has produced novel modeling techniques for SIW components, a number of new technological solutions, as well as SIW circuits and systems with outstanding performance. The increasing number of scientific publications on SIW technology confirms the growing interest of the scientific community (Fig. 2).

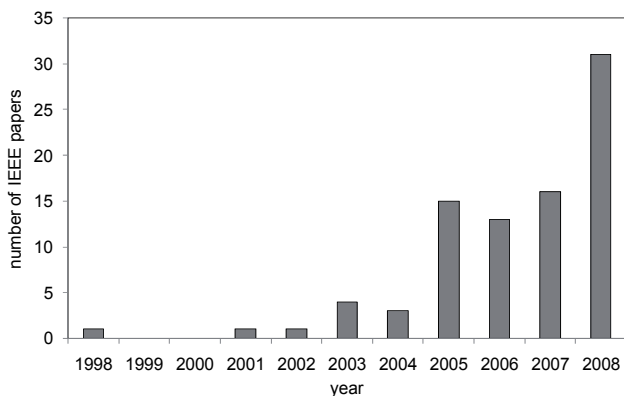

Fig. 2. Number of publications on the SIW in IEEE journals (source: ieeexplore.ieee.org).

This paper presents an overview of the current status and future trends of research on SIW technology. The paper is organized as follows: Sec. 2 describes the historical development of SIW components; Sec. 3 outlines the most significant current research topics; finally, the future research trends are discussed in Sec. 4.

2. Historical Development

One of the firstly developed embedded structures with the name of laminated waveguide [6] dates back to 1998. The SIW technology has been subsequently applied to several microwave and millimeter-wave components, including active circuits, passive components, and antennas. Note that the integrated waveguide techniques were proposed much earlier and it was filed as a patent [5] but rare attention was paid to this work until about 2000 when this SIW scheme has been unified within the concept of SICs. Of course, a much earlier version of embedded resonators was also presented but it is debatable whether we should call those structures as part of substrate integrated circuits.

2.1 Passive SIW Components

Concerning the passive circuits, most of the classical microwave components have been implemented in SIW technology. This solution usually permits to obtain components with a substantial reduction in size if compared to classical waveguide components; moreover, their losses are lower than in the corresponding microstrip devices, especially in the millimeter-wave frequency range, and there are no radiation and packaging problems. Among the passive components, filters have received a particular attention. A variety of different filter topologies were proposed: among them, a filter with inductive-post operating at 28 GHz [7] and a filter with irises operating at 60 GHz [12] were designed and fabricated. Subsequently, cavity filters with circular [13] and rectangular cavities [14] were developed: they permit a better design flexibility and exhibit higher selectivity, thanks to the cross-coupling that introduces transmission zeros. A multilayered structure was adopted in [15]: the use of a two-layer substrate permitted to design an elliptic filter with four cavities operating in C band. Compact and super-wide band-pass filters were presented in [16]: due to the use of an electromagnetic band-gap (EBG) structure in the ground plane, a band-pass filter covering the frequency range 8.5-16.5 GHz was designed and tested. While most of these filters operate in the microwave range, filters operating at 60 GHz [12] and up to 180 GHz [17] were also proposed.

Besides filters, several other passive components have been developed in SIW technology. Among them, two configurations of directional couplers were proposed: the former, based on two adjacent SIW with apertures in the common wall, was used to design 3-dB, 6-dB, and 10-dB couplers [18]; the second configuration presents a cruciform shape, and was adopted to design a super-compact 3-dB directional coupler [19]. Planar SIW diplexers operating at 5 GHz and 25 GHz were proposed [20,21]. A magic-T [22], six-port circuits [23], [24], and circulators [25], [26] were also implemented and experimentally verified.

2.2 Active SIW Components

SIW technology was also used to implement several active components, thus exploiting the advantage of an easy integration of the active elements with the waveguide components. In particular, a feedback oscillator was proposed in [27]: it operates at 12 GHz and is based on an SIW cavity that acts as a frequency selector as well as a feedback-coupling device. Another topology was adopted in the Ka-Band oscillator proposed in [28], where a Gunn diode is mounted in series with an SIW resonant cavity. An X-band single-balanced SIW mixer was presented in [29]: thanks to the use of an SIW hybrid coupler with excellent performance over a very broad band, the mixer exhibits an operation bandwidth from 8.5 to 12 GHz. A compact X-band single-transistor amplifier with SIW-based input and output matching networks was proposed

in [30]. Conversely, four-device power amplifier operating at 35 GHz was presented in [31]: it exhibits good power-combining efficiency along with a good heat sink.

2.3 SIW Antennas

In the last years, there is a growing interest for SIW-based antennas. Several configurations have been proposed: the first SIW antenna was based on a four-by-four slotted SIW array operating at 10 GHz, obtained by etching longitudinal slots in the top metal surface of an SIW [32]. Another topology was the leaky-wave antennas [33]: this antenna makes use of one of the fundamental characteristics of this synthetic waveguide, namely, its property to generate leakage loss when the longitudinal spacing of the metal vias is sufficiently large. A modified Vivaldi radiator was also proposed [34]: it consists in a dual V-type linearly tapered slot antenna, with center frequency at 36 GHz.

3. Current Research Topics

Hot topics in the current research on SIW components are related to the development of efficient full-wave analysis techniques for the modeling and design of SIW components including multilayered topologies, to the design of compact, broadband and low-loss interconnects, and to the modeling and minimization of losses.

3.1 Modeling and Design

The modeling of SIW components is typically performed by using full-wave numerical techniques. Both commercial electromagnetic software and specifically developed numerical techniques have been adopted. Electromagnetic codes based on integral-equation, finite-element or finite difference methods have been implemented [35]-[39].

A particularly efficient numerical technique for the modeling of arbitrarily shaped SIW components is based on the Boundary Integral-Resonant Mode Expansion (BI-RME) method [38], [39]. The BI-RME method, developed for the modeling of classical waveguide components, was originally applied to the modeling of SIW components in the lossless case. Under the hypothesis of negligible radiation loss, the components can be laterally closed by fictitious metal walls without modifying their physical behavior (Fig. 3a). The BI-RME method allows characterizing SIW components through their generalized admittance matrix \mathbf{Y} expressed in the form of a pole expansion in the frequency domain, relating modal currents and voltages of the port modes. The generic element of matrix \mathbf{Y} is given by

$$Y_{ij}(k_0) = \frac{A_{ij}}{j\eta_0 k_0} + \frac{jk_0 \epsilon_r}{\eta_0} B_{ij} + \frac{jk_0^3 \epsilon_r^2}{\eta_0} \sum_{p=1}^P \frac{C_{ip} C_{jp}}{k_p^2 (k_p^2 - k_0^2 \epsilon_r)} \quad (1)$$

where $k_0 = \omega/c$ is the wave-number at the frequency of interest, c is the speed of light in vacuum, η_0 is the charac-

teristic impedance in vacuum, and ϵ_r is the relative dielectric permittivity of the substrate. The terms A_{ij} and B_{ij} are related to the low-frequency behavior of the admittance matrix, k_p is the resonance wave-number of the p -th mode of the cavity obtained by short-circuiting the ports, and C_{ip} is related to the coupling between the i -th port mode and the p -th cavity mode. The quantities A_{ij} , B_{ij} , C_{ip} , and k_p in (1) are frequency independent and are calculated very efficiently by the BI-RME method [40]. Once these quantities are known, the admittance parameters of the SIW component can be computed at any frequency by using (1) in a negligible time.

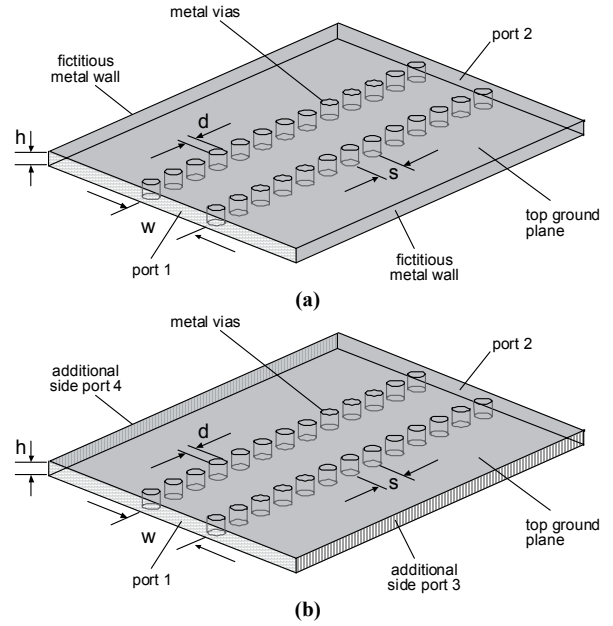

Fig. 3. Geometry of an SIW structure considered in the BI-RME analysis: (a) lossless case, with fictitious metal side-walls; (b) lossy case, with additional side-radiation absorbing ports.

Therefore, the major advantage of the BI-RME method is the possibility to determine in one shot the wide-band expression of the frequency response of SIW components, thus avoiding repeated frequency-by-frequency electromagnetic analyses. Consequently, the BI-RME modeling of SIW components typically requires few seconds on a standard personal computer.

The formulation of the BI-RME method for the modeling of SIW components has been recently extended to include the effect of dielectric, conductor, and radiation losses [39]. Conductor and dielectric losses have been incorporated by adding the quality factor of the cavity modes in expression (1), which thus results:

$$Y_{ij}(k_0) = \frac{A_{ij}}{j\eta_0 k_0} + \sigma_d B_{ij} + \frac{jk_0 \epsilon_r}{\eta_0} B_{ij} + \frac{k_0^2 \epsilon_r^{3/2}}{\eta_0} \sum_{p=1}^P \frac{C_{ip} C_{jp}}{k_p^1 Q_p (k_p^2 + jk_0 k_p^1 \epsilon_r^{1/2} / Q_p - k_0^2 \epsilon_r)} + \frac{jk_0^3 \epsilon_r^2}{\eta_0} \sum_{p=1}^P \frac{C_{ip} C_{jp}}{k_p^2 (k_p^2 + jk_0 k_p^1 \epsilon_r^{1/2} / Q_p - k_0^2 \epsilon_r)} \quad (2)$$

where Q_p is the quality factor of the p -th cavity mode, depending on both the conductivity σ_d of the dielectric medium and the conductivity σ_c of the metal. Conversely, radiation loss are included by defining additional side ports (Fig. 3b), which are then closed with matched loads.

Another significant advantage of the BI-RME method is the possibility to directly determine equivalent circuit models of SIW discontinuities [41]. Due to the particular representation of the admittance matrix given in (1), the generic element Y_{ij} of matrix \mathbf{Y} directly represents the parallel of an inductance, a capacitance, and P LC-series resonators (Fig. 4). Moreover, the values of the lumped elements are analytically derived from A_{ij} , B_{ij} , C_{ip} , and k_p . Equivalent circuit models including losses can be derived from (2): in this case, the generic element Y_{ij} represents the parallel of an inductance, a capacitance, a resistance, and P RLC-series resonators [42].

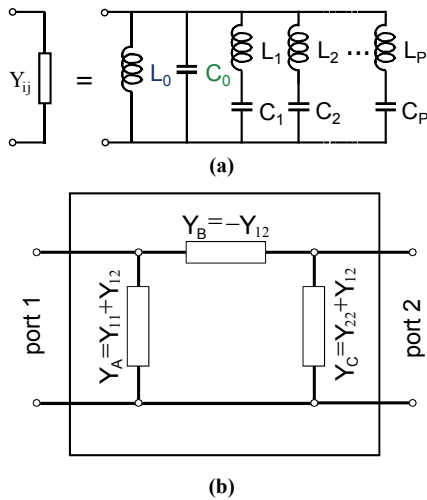

Fig. 4. Equivalent circuit model directly derived from the BI-RME analysis: (a) equivalent model of Y_{ij} ; (b) topology of the generic π -type equivalent circuit model, in the case of a two-port component.

The most important application of the proposed method is the determination of parametric multimodal equivalent circuit models, where the values of the lumped elements depend on the geometrical dimensions of the component [41]. In fact, once a library of equivalent circuit models is available, the direct synthesis of a component can be performed in a short time by using conventional circuit CAD tools, with no need of electromagnetic full-wave analysis codes.

3.2 Compact and Wideband Interconnects

SIW interconnects represent a valid alternative to microstrip lines and coplanar waveguides, as they reduce losses and radiation leakage, especially in the mm-wave range. Nevertheless, SIW structures are limited in compactness and bandwidth. The width of the SIW is related to the cutoff frequency of the fundamental mode, and it is smaller of a factor $\epsilon_r^{-1/2}$ compared to a hollow rectangular

waveguide with the same cutoff frequency. The operation bandwidth is limited to one octave (from the cutoff frequency f_1 of the fundamental mode to cutoff frequency $f_2 = 2f_1$ of the second mode), corresponding to the mono-modal bandwidth of the waveguide.

Different waveguide topologies have been recently proposed to improve the compactness of SIW structures. The substrate integrated folded waveguide (SIFW) was proposed in [43]: a metal septum permits to fold the waveguide, thus reducing the size by a factor of more than two at the cost of slightly larger losses. The half-mode substrate integrated waveguide (HMSIW) was introduced in [44]: based on the approximation of the vertical cut of the waveguide as a virtual magnetic wall, it permits a size reduction of nearly 50%. A combination of the two techniques was also proposed [45], resulting in the folded half-mode substrate integrated waveguide (FHMSIW), which leads to a further size reduction.

To improve the bandwidth performance, some waveguide configurations have been developed. The substrate integrated slab waveguide (SISW) was proposed in [46]: it consists of an SIW where the dielectric medium is periodically perforated with air-filled holes, located in the lateral portion of the waveguide. This approach allowed the design of a waveguide with a mono-modal band from 7.5 Hz to 18 Hz, which should be extended further if geometrical and material parameters are adequately selected. The implementation of the ridge waveguide in SIW technology was proposed in [47], where the ridge was implemented through a row of thin, partial-height metal posts located in the center of the wider side of the waveguide. This structure allowed for achieving a 37% bandwidth enhancement. Nevertheless, the useful bandwidth of this structure is limited by a band-gap, which appears when the ridge posts are thick and long.

A novel class of substrate integrated waveguides, based on the concept of the classical ridge rectangular waveguide, was proposed in [48]. The structure is integrated in a dielectric substrate with top and bottom metal layers, and comprises two sided rows of full-height metal cylinders and a central row of partial-height metal posts, connected at their bottom by a metal strip (Fig. 5a). Based on this structure, a prototype covering the frequency band from 6.8 GHz to 25 GHz was designed and tested (Fig. 5b).

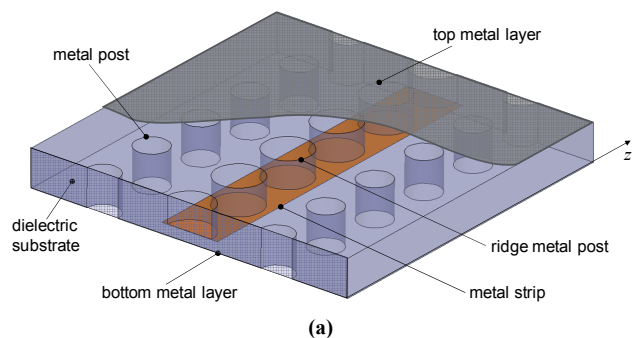

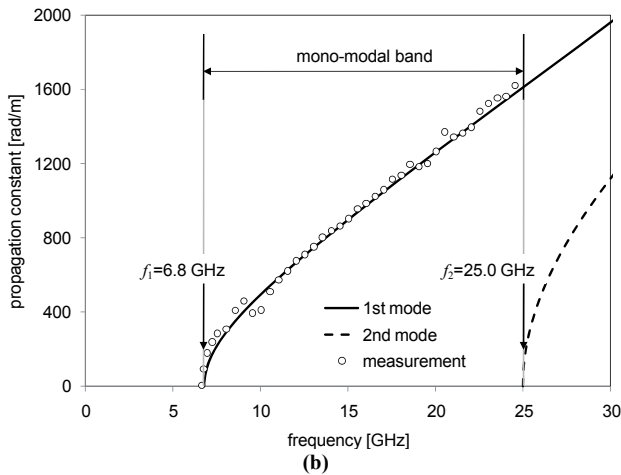

Fig. 5. Ridge substrate integrated waveguide: (a) geometry of the structure; (b) simulated and measured propagation constant of the first two modes.

The proposed structure exhibits a mono-modal bandwidth three times broader than classical rectangular waveguides or substrate integrated waveguides, and its size is half of a substrate integrated waveguide with the same cutoff frequency.

3.3 Loss Minimization

One of the major issues in the design of SIW components is related to the minimization of losses, especially when operating in the mm-wave frequency range. There are three mechanisms of loss in the SIW structures [39], [49]. Due to their similarity to rectangular waveguides, SIW structures exhibit conductor losses due to the finite conductivity of metallic walls and dielectric losses due to the loss tangent of dielectric substrate. Moreover, the presence of gaps in the SIW structures along the side walls can determine a radiation loss, due to a possible leakage through the gaps.

The different kinds of losses in substrate integrated waveguide interconnects can be minimized by modifying some geometrical parameters, namely the substrate thickness h , the diameter d of the metal vias, and their longitudinal spacing s (Fig. 3).

The thickness h of the dielectric substrate plays an important role. Increasing h (while keeping the other dimensions unchanged) determines a significant reduction in the conductor loss but has no effect on the dielectric loss. In general, radiation loss is not affected by the substrate thickness (at least, as long as h is smaller than a half wavelength). There is a simple physical explanation of these phenomena. With regard to the conductor loss, they depend on the surface integral of $|\mathbf{J}|^2$ on the metal surface, where \mathbf{J} represents the electric current density flowing on the metal surface (more specifically, on the top and bottom metal layers and on the surface of the metal vias). Increasing h determines a reduction of $|\mathbf{J}|$ proportional to \sqrt{h} . Consequently, the conductor loss on the top and bottom surfaces scales as $1/h$. On the contrary, since the lateral surface of

metal vias linearly increases with h , the increased integration surface compensates the reduction of $|\mathbf{J}|^2$, and therefore the contribution of the metal vias to conductor loss is unchanged with h . With regard to the dielectric loss, it depends on the volume integral of $|\mathbf{E}|^2$ (where \mathbf{E} represents the electric field) over the whole volume of the substrate. Since increasing h determines a reduction of $|\mathbf{E}|$ proportional to \sqrt{h} , but the volume of the substrate linearly increases with h , the dielectric loss does not vary with h . It is finally noted that the same dependence of losses on the thickness h is encountered in the fundamental mode of classical rectangular waveguides and, in general, in any H-plane waveguide circuit.

Another important geometrical parameter is the diameter d of the metal vias. The variation of the conductor and dielectric losses versus d is limited. In particular, the conductor loss slightly decreases when increasing the diameter d of the vias: as already stated, the conductor loss depends on the surface integral of $|\mathbf{J}|^2$. In this case, the contribution from the top and bottom metal layers is practically unchanged, whereas the contribution from the metal vias varies. Assuming that the current flowing on the surface of each via is practically unchanged, the surface increases with d and therefore $|\mathbf{J}|$ scales as $1/d$. Since the integration surface increases proportionally to d , the surface integral of $|\mathbf{J}|^2$ decreases as $1/d$. Conversely, the dielectric loss is practically independent on the diameter d . This physical explanation is valid for most cases of practical interest: if the spacing between the metal vias is extremely small, a more sophisticated explanation is needed, to take into account the variation of the current distribution due to "proximity effects". Finally, the radiation leakage becomes significant when the condition $s/d < 2.5$ is not met [8].

A similar behavior is observed when varying the longitudinal spacing s . When decreasing the value of s , the conductor loss decreases (because of the increased metal surface) and the dielectric loss practically remains unchanged. With regards to the radiation loss, it remains small under the condition $s/d < 2.5$ [8].

Finally, it is important to remark that dielectric and conductor losses exhibit a different dependence on frequency [49]: it results that the dielectric loss is typically the most significant contribution to losses in the mm-wave frequency range. For this reason, the optimization of the geometry has a marginal effect on the minimization of losses at mm-waves. In this case, a careful selection of the dielectric material is extremely important.

4. Future Research Trends

The future activities on SIW technology will be mainly devoted to the deployment of mm-wave components in the frequency band between 60 and 350 GHz, to the investigation of new materials and fabrication technologies, and to the integration of complete systems in

SIW technology based on the System-on-Substrate approach. Of course, the integration of SIW components with other substrate integrated structures would be of great interest to design some innovative circuits and systems.

The implementation of SIW components in the mm-wave frequency range will require the development of novel structures, with the aim to reduce the size, improve the bandwidth, and especially minimize the losses. These structures can be based on multilayered configurations, which provide more design flexibility while maintaining the advantage of the planar and low-cost fabrication technology. Of course, the availability of novel SIW structures will foster the development of more efficient components and circuits with advanced performance and/or able to integrate more functions in the same component. At the same time, it will require the design of novel wideband transitions (e.g., from microstrip and coplanar lines to multilayered SIW components). Moreover, technological constraints become more critical when increasing the frequency: consequently, solutions based on metalized slots instead of metal vias could mitigate this issue.

The availability of SIW components in the frequency band between 60 and 350 GHz will open interesting perspectives for novel applications and new markets. The technological development will permit to design novel compact and broadband components to meet the needs of UWB systems, scientific instrumentation, and low-cost commercial circuits for telecommunications. Among the possible components of practical interest, there are compact, high-order, bimodal filters for space applications, band-pass filters with very broad pass band for application in measurement instrumentation, six-port circuits for application to software-defined radio, circuits including active devices for radiometers at 35 and 94 GHz, diplexers and antennas for automotive radars at 77 and 94 GHz.

Another research trend is related to the use of new materials and different technologies for the fabrication of SIW components: adopting LTCC (low-temperature co-fired ceramic) or HTCC (high-temperature co-fired ceramic) will open completely new scenarios for the applicability of SIW structures. The use of these technologies will permit the fabrication of 3D SIW components, which could add further design flexibility and lead to novel solutions with better performance. On the contrary, the use of CMOS technology appears to be more critical, due to the extremely thin dielectric layers and the low-conductivity metal. Advanced materials including smart materials and electro-optical materials as well as nano-structured materials will play critical roles in the design and development of innovative SIW circuits and systems.

The most promising research trend is related to the System-on-Substrate approach. Currently, the production of RF or microwave circuits is based on the System-in-Package concept: a portion of the circuit is integrated in a chip-set, which may include oscillators, mixers, low-noise amplifiers; the remaining part is usually fabricated in printed planar technology (microstrip or coplanar

waveguides) and comprises power amplifiers, selective filters, antennas. Finally, all the components are mounted on the same board. The use of microstrip or coplanar waveguides is particularly convenient below 30 GHz, but it becomes unpractical at higher frequency, due to prohibitively high loss and interference between adjacent circuits, and therefore an alternative fabrication technology is needed for mm-wave systems. The use of the SIW technology for replacing microstrip or coplanar waveguides in mm-wave wireless systems appears very promising. In this way, the System-in-Package concept will be overcome by the System-on-Substrate approach, where all the components not included in the chip-set are fabricated in SIW technology. This solution brings several advantages: SIW technology is cost-effective and permits to fabricate components with low loss and complete shielding. Moreover, all components are fabricated on the same substrate, thus avoiding transitions and interconnections that increase losses and parasitics. Recently, complete circuits and front-end in SIW technology have been proposed and experimentally verified [11],[50]. This approach appears to be the most promising candidate for the implementation of mm-wave circuits and systems for the next decade.

5. Conclusion

This paper has presented an overview of substrate integrated waveguide technology, which represents a very promising candidate for the integration of mm-wave circuits and systems in the next decade.

A significant effort has been devoted in past years to the development of active and passive SIW components as well as SIW antennas. Currently, the research is oriented to the investigation of novel SIW structures, which can operate at higher frequency with low losses and outstanding performance.

The future trend is the integration of complete systems in SIW technology, according to the System-on-Substrate concept. This approach could replace the current System-on-Chip and System-in-Package, and become the paradigm for mm-wave circuits and systems.

Acknowledgements

This work was partially carried out in the framework of COST Action IC0803-RF / Microwave Communication Subsystems for Emerging Wireless Technologies (RFCSET).

References

- [1] DANIELS, R. C., HEATH, R. W. 60 GHz wireless communications: emerging requirements and design recommendations. *IEEE Vehicular Technology Magazine*, 2007, vol. 2, no. 3, pp. 41-50.
- [2] FLEMING, W. J. New automotive sensors—A review. *IEEE Sensors Journal*, 2008, vol. 8, no. 11, pp. 1900-1921.

- [3] YUJIRI, L., SHOUCRI, M., MOFFA, P. Passive millimeter wave imaging. *IEEE Microwave Magazine*, 2003, vol. 4, no. 3, pp. 39 to 50.
- [4] MIZUNO, K., WAGATSUMA, Y., WARASHINA, H., SAWAYA, K., SATO, H., MIYANAGA, S., YAMANAKA, Y. Millimeter-wave imaging technologies and their applications. In *IEEE International Vacuum Electronics Conference, IVEC '07*, 15-17 May 2007.
- [5] SHIGEKI, F. *Waveguide Line* (in Japanese). *Japan Patent* 06-053 711, Feb. 25, 1994.
- [6] HIROSHI, U., TAKESHI, T., FUJII, M. Development of a 'laminated waveguide'. *IEEE Trans. on Microwave Theory and Techniques*. 1998, vol. 46, no. 12, pp. 2438–2443.
- [7] DESLANDES, D., WU, K. Single-substrate integration technique of planar circuits and waveguide filters. *IEEE Trans. on Microwave Theory and Techniques*, 2003, vol. 51, no. 2, pp. 593 - 596.
- [8] XU, F., WU, K. Guided-wave and leakage characteristics of substrate integrated waveguide. *IEEE Trans. on Microwave Theory and Techniques*, 2005, vol. 53, no. 1, pp. 66-73.
- [9] DESLANDES, D., WU, K. Accurate modeling, wave mechanisms, and design considerations of a substrate integrated waveguide. *IEEE Trans. on Microwave Theory and Techniques*, 2006, vol. 54, no. 6, pp. 2516–2526.
- [10] WU, K. Towards System-on-Substrate approach for future millimeter-wave and photonic wireless applications. In *Proc. of Asia-Pacific Microwave Conference*, 2006.
- [11] LI, Z., WU, K. 24-GHz frequency-modulation continuous-wave radar front-end System-on-Substrate. *IEEE Trans. on Microwave Theory and Techniques*, 2008, vol. 56, no. 2, pp. 278-285.
- [12] CHOI, S. T., YANG, K. S., TOKUDA, K., KIM, Y. H. A V-band planar narrow bandpass filter using a new type integrated waveguide transition. *IEEE Microwave and Wireless Components Letters*, 2004, vol. 14, no. 12, pp. 545-547.
- [13] TANG, H. J., HONG, W., HAO, Z. C., CHEN, J. X., WU, K. Optimal design of compact millimetre-wave SIW circular cavity filters. *Electronics Letters*, 2005, vol. 41, no. 19.
- [14] CHEN, X.-P., WU, K. Substrate Integrated Waveguide cross-coupled filter with negative coupling structure. *IEEE Trans. on Microwave Theory and Techniques*, 2008, vol. 56, no. 1, pp. 142 to 149.
- [15] HAO, Z. C., HONG, W., CHEN, X. P., CHEN, J. X., WU, K., CUI, T. J. Multilayered Substrate Integrated Waveguide (MSIW) elliptic filter. *IEEE Microwave and Wireless Components Letters*, 2005, vol. 15, no. 2, pp. 95–97.
- [16] HAO, Z. C., HONG, W., CHEN, X. P., CHEN, J. X., WU, K. Compact super-wide bandpass Substrate Integrated Waveguide (SIW) filters. *IEEE Trans. on Microwave Theory and Techniques*, 2005, vol. 53, no. 9, pp. 2968–2977.
- [17] STEPHENS, D., YOUNG, P. R., ROBERTSON, I. D. Millimeter-wave substrate integrated waveguides and filters in photoimageable thick-film technology. *IEEE Trans. on Microwave Theory and Techniques*, 2005, vol. 53, no. 12, pp. 3832-3838.
- [18] HAO, Z. C., HONG, W., CHEN, J. X., ZHOU, H. X., WU, K. Single-layer substrate integrated waveguide directional couplers. *IEE Proc. Microwaves, Antennas and Propagation*, 2006, vol. 153, no. 5, pp. 426–431.
- [19] DJERAFI, T., WU, K. Super-compact Substrate Integrated Waveguide cruciform directional coupler. *IEEE Microwave and Wireless Components Letters*, 2007, vol. 17, no. 11, pp. 757–759.
- [20] HAO, Z. C., HONG, W., CHEN, X. P., CHEN, J. X., WU, K. Planar diplexer for microwave integrated circuits. *IEE Proc. Microwaves, Antennas Propagation*, 2005, vol. 152, no. 6, pp. 455–459.
- [21] TANG, H. J., HONG, W., CHEN, J.-X., LUO, G. Q., WU, K. Development of millimeter-wave planar diplexers based on complementary characters of dual-mode substrate integrated waveguide filters with circular and elliptic cavities. *IEEE Trans. on Microwave Theory and Techniques*, 2007, vol. 55, no. 4, pp. 776–782.
- [22] HE, F. F., WU, K., HONG, W., TANG, H. J., ZHU, H. B., CHEN, J. X. A planar magic-T using Substrate Integrated Circuits concept. *IEEE Microwave and Wireless Components Letters*, 2008, vol. 18, no. 6, pp. 386–388.
- [23] XU, X., BOSISIO, R. G., WU, K. A new six-port junction based on Substrate Integrated Waveguide technology. *IEEE Trans. on Microwave Theory and Techniques*, 2005, vol. MTT-53, no. 7, pp. 2267 - 2273.
- [24] MOLDOVAN, E., BOSISIO, R. G., WU, K. W-band multiport substrate-integrated waveguide circuits. *IEEE Trans. on Microwave Theory and Techniques*, 2006, vol. 54, no. 2, pp. 625 to 632.
- [25] D'ORAZIO, W., WU, K., HELSZAJN, J. A substrate integrated waveguide degree-2 circulator. *IEEE Microwave and Wireless Components Letters*, 2004, vol. 14, no. 5, pp. 207–209.
- [26] D'ORAZIO, W., WU, K., Substrate-integrated-waveguide circulators suitable for millimeter-wave integration. *IEEE Trans. on Microwave Theory and Techniques*, 2006, vol. MTT 54, no. 10, pp. 3675-3680.
- [27] CASSIVI, Y., WU, K. Low cost microwave oscillator using substrate integrated waveguide cavity. *IEEE Microwave and Wireless Components Letters*, 2003, vol. 13, no. 2, pp. 48 - 50.
- [28] C. ZHONG, J. XU, Z. YU and Y. ZHU, Ka-Band Substrate Integrated Waveguide Gunn Oscillator, *IEEE Microwave and Wireless Comp. Letters*, Vol. 18, No. 7, pp. 461–463, July 2008.
- [29] CHEN, J.-X., HONG, W., HAO, Z.-C., LI, H., WU, K. Development of a low cost microwave mixer using a broad-band Substrate Integrated Waveguide (SIW) coupler. *IEEE Microwave and Wireless Components Letters*, 2006, vol. 16, no. 2.
- [30] JIN, H., WEN, G. A novel four-way Ka-band spatial power combiner based on HMSIW. *IEEE Microwave and Wireless Components Letters*, 2008, vol. 18, no. 8, pp. 515-517.
- [31] ABDOLHAMIDI, M., SHAHABADI, M. X-band substrate integrated waveguide amplifier. *IEEE Microwave and Wireless Components Letters*, 2008, vol. 18, no. 12, pp. 815-817.
- [32] YAN, L., HONG, W., HUA, G., CHEN, J., WU, K., CUI, T. J. Simulation and experiment on SIW slot array antennas. *IEEE Microwave and Wireless Components Letters*, 2004, vol. 14, no. 9, pp. 446-448.
- [33] DESLANDES, D., WU, K. Substrate integrated waveguide leaky-wave antenna: Concept and design considerations. In *Asia-Pacific Microwave Conf. Proc.* (APMC'05). Suzhou (China), 2005.
- [34] CHENG, Y. J., HONG, W., WU, K. Design of a monopulse antenna using a Dual V-Type Linearly Tapered Slot Antenna (DVL TSA). *IEEE Trans. on Antennas and Propagation*, 2008, vol. 56, no. 9, pp. 2903–2909.
- [35] CASSIVI, Y., PERREGRINI, L., ARCIONI, P., BRESSAN, M., WU, K., CONCIAURO, G. Dispersion characteristics of substrate integrated rectangular waveguide. *IEEE Microwave and Wireless Components Letters*, 2002, vol. 12, no. 9, pp. 333-335.
- [36] XU, F., ZHANG, Y., HONG, W., WU, K., CUI, T. J. Finite-difference frequency-domain algorithm for modeling guided-wave properties of substrate integrated waveguide. *IEEE Trans. on Microwave Theory and Techniques*, 2003, vol. 51, no. 11, pp. 2221-2227.
- [37] YAN, L., HONG, W., WU, K., CUI, T. J. Investigations on the propagation characteristics of the substrate integrated waveguide based on the method of lines. *Proc. IEE—Microwave Antennas and Propagation*, 2005, vol. 152, pp. 35–42.

- [38] XU, F., WU, K., HONG, W. Domain decomposition FDTD algorithm combined with numerical TL calibration technique and its application in parameter extraction of substrate integrated circuits. *IEEE Trans. on Microwave Theory and Techniques*, 2006, vol. 54, no. 1, pp. 329-338.
- [39] BOZZI, M., PERREGRINI, L., WU, K. Modeling of conductor, dielectric and radiation losses in substrate integrated waveguide by the boundary integral-resonant mode expansion method. *IEEE Trans. on Microwave Theory and Techniques*, 2008, vol. 56, no. 12, pp. 3153-3161.
- [40] CONCIAURO, G., GUGLIELMI, M., SORRENTINO, R. *Advanced Modal Analysis*. John Wiley and Sons, 2000.
- [41] BOZZI, M., PERREGRINI, L., WU, K. A novel technique for the direct determination of multi-mode equivalent circuit models for substrate integrated waveguide discontinuities. *Intern. Journal of RF and Microwave Computer-Aided Engineering*, July 2009, vol. 19, no. 4.
- [42] BOZZI, M., PERREGRINI, L., WU, K. Modeling of losses in substrate integrated waveguide by boundary integral-resonant mode expansion method. In *IEEE MTT-S International Microwave Symposium (IMS2008)*. Atlanta (GA, USA), June 10-15, 2008.
- [43] GRIGOROPOULOS, N., IZQUIERDO, B. S., YOUNG, P. R. Substrate integrated folded waveguides (SIFW) and filters. *IEEE Microwave Wireless Component Letters*, 2005, vol. 15, no. 12, pp. 829-831.
- [44] HONG, W., WANG, Y., LAI, Q. H., LIU, B. Half mode substrate integrated waveguide: A new guided wave structure for microwave and millimeter wave application. In *Proc. Joint 31st Int. Conf. Infrared Millimeter Waves 14th Int. Conf. Terahertz Electronics*. Shanghai (China), 2006, p. 219.
- [45] ZHAI, G. H., HONG, W., WU, K., CHEN, J. X., CHEN, P., WEI, J., TANG, H. J. Folded half mode substrate integrated waveguide 3 dB coupler. *IEEE Microwave and Wireless Components Letters*, 2008, vol. 18, no. 8, pp. 512-514.
- [46] BOZZI, M., DESLANDES, D., ARCIONI, P., PERREGRINI, L., WU, K., CONCIAURO, G. Efficient analysis and experimental verification of substrate integrated slab waveguides for wideband microwave applications. *Intern. J. of RF and Microwave Computer-Aided Engineering*, May 2005, vol. 15, no. 3, pp. 296-306.
- [47] CHE, W., LI, C., RUSSER, P., CHOW, Y. L. Propagation and band broadening effect of planar integrated ridged waveguide in multilayer dielectric substrates. In *IEEE MTT-S International Microwave Symposium Digest (IMS 2008)*. Atlanta (GA), June 15-20, 2008, pp. 217-220.
- [48] BOZZI, M., WINKLER, S. A., WU, K. Novel compact and broadband interconnects based on ridge substrate integrated waveguide. In *2009 IEEE MTT-S International Microwave Symposium (IMS2009)*. Boston (MA, USA), June 7-12, 2009.
- [49] BOZZI, M., PASIAN, M., PERREGRINI, L., WU, K. On the losses in substrate integrated waveguides. In *37th European Microwave Conference (EuMC 2007)*. Munich (Germany), Oct. 8-12, 2007.
- [50] SAMANTA, K. K., STEPHENS, D., ROBERTSON, I. D. Design and performance of a 60-GHz multi-chip module receiver employing substrate integrated waveguides. *IET Microwave Antennas Propagation*, 2007, vol. 1, no. 5, pp. 961-967.

About Authors...

Maurizio BOZZI was born in Voghera, Italy, in 1971. He received the "Laurea" degree in Electronic Engineering and the Ph.D. in Electronics and Computer Science from

the University of Pavia, Italy, in 1996 and 2000, respectively. In 2002 he became Assistant Professor in Electromagnetics at the Dept. of Electronics, University of Pavia, where he currently teaches the course of Numerical Techniques for Electromagnetics. He held research positions in European and American universities, including the Technical University of Darmstadt, Germany, the University of Valencia, Spain, and the Polytechnical University of Montreal, Canada. His research activities concern the development of numerical methods for the electromagnetic modeling of microwave and millimeter-wave components. Dr. Bozzi received the Best Young Scientist Paper Award at the XXVII General Assembly of URSI in 2002, and the MECSA Prize for the best paper presented at the Italian Conference on Electromagnetics in 2000.

Luca PERREGRINI was born in Sondrio, Italy, in 1964. He received the "Laurea" degree in Electronic Engineering and the Ph.D. in Electronics and Computer Science from the University of Pavia, Pavia, Italy, in 1989 and 1993, respectively. In 1992, he joined the Dept. of Electronics, University of Pavia, where he is now an Associate Professor in Electromagnetics. His main research interests are in numerical methods for the analysis and optimization of waveguide circuits, frequency selective surfaces, reflectarrays, and printed microwave circuits. He co-authored the textbook *Fondamenti di Onde Elettromagnetiche* (Milano, Italy, McGraw-Hill Italia, 2003). Prof. Perregrini was an Invited Professor at the Polytechnical University of Montreal, Montreal, Quebec, Canada in 2001, 2002, and 2004. He was a consultant of the European Space Agency and of some European telecommunication companies.

Ke WU is Professor of Electrical Engineering, and Canada Research Chair in RF and millimeter-wave engineering at the Ecole Polytechnique (University of Montreal). He has been the Director of the Poly-Grames Research Center and the Founding Director of the Center for Radiofrequency Electronics Research of Quebec. He has authored or co-authored over 670 referred papers, and a number of books/book chapters and patents. Dr. Wu has held key positions in and has served on various panels and international committees including the chair of technical program committees, international steering committees and international conferences/symposia. In particular, he will be the general chair of the 2012 IEEE MTT-S International Microwave Symposium. He has served on the editorial/review boards of many technical journals, transactions and letters as well as scientific encyclopedia including editors and guest editors. Dr. Wu is an elected IEEE MTT-S AdCom member for 2006-2012 and serves as the chair of the IEEE MTT-S Transnational Committee. He was the recipient of many awards and prizes including the first IEEE MTT-S Outstanding Young Engineer Award and the 2004 Fesenden Medal of the IEEE Canada. He is a Fellow of the IEEE, a Fellow of the Canadian Academy of Engineering (CAE) and a Fellow of the Royal Society of Canada (The Canadian Academy of the Sciences and Humanities). He is an IEEE MTT-S Distinguished Micro-wave Lecturer from Jan. 2009 to Dec. 2011.

Paolo ARCIONI received the Laurea degree in Electronic Engineering from the University of Pavia, Italy, in 1973. In 1974 he joined the Dept. of Electronics, University of Pavia, where he currently teaches microwave theory as a Full Professor. In 1991, he was a Visiting Scientist at the Stanford Linear Accelerator Center (SLAC), Stanford, CA, where he worked in cooperation with the RF Group to design optimized cavities for the PEP II Project. From 1992 to 1993, he collaborated with the “Istituto Nazionale di Fisica Nucleare” (INFN), Frascati, Italy, on the design of the accelerating cavities for the DAΦNE storage ring. In

2004, he became Head of the Dept. of Electronics, University of Pavia. His research activity has concerned the design of compensated structures for linear accelerators, the development of microwave equipment for EPR, the investigation of ferrite tuning of power magnetrons, the study of a novel numerical technique (the Boundary Integral–Resonant Mode Expansion, BI–RME, method) for the modeling of waveguide and microstrip circuits, and recently the modeling of planar components on semiconductor substrates and of integrated structures for millimeter-wave circuits.

RADIOENGINEERING REVIEWERS

June 2009, Volume 18, Number 2

- MEDVED-ROGINA, B., University of Zagreb, Croatia
- MIKKELSEN, J., Aalborg University, Denmark
- NICOLE, P., Thales Systemes Aeroportes S.A., France
- PETRŽELA, J., Brno Univ. of Technology, Czechia
- PIKSA, P., Czech Technical University in Prague, Czechia
- POLÍVKA, M., Czech Technical University in Prague, Czechia
- POUPA, M., University of West Bohemia, Pilsen, Czechia
- PRADES, C. F., Centre Tecnologic de Telecomunicacions de Catalunya, Spain
- PROKOPEC, J., Brno Univ. of Technology, Czechia
- RAIDA, Z., Brno University of Technology, Czechia
- RIDZOŇ, R., Technical University of Košice, Slovakia
- SCHEJBAL, V., University of Pardubice, Jan Perner Transport Faculty, Czechia
- SMUTNÝ, L., VŠB - Technical University of Ostrava, Czechia
- SYROVÁTKA, B., Czech Technical University in Prague, Czechia
- ŠEBESTA, J., Brno Univ. of Technology, Czechia
- ŠEBESTA, V., Brno Univ. of Technology, Czechia
- ŠKVOR, Z., Czech Technical University in Prague, Czechia
- ŠOCHMAN, J., Czech Technical University in Prague, Czechia
- ŠUBRT, O., Czech Technical University in Prague, Czechia
- URBANEC, T., Brno Univ. of Technology, Czechia
- VALERIO, G., La Sapienza University of Rome, Italy
- VÁGNER, P., Brno Univ. of Technology, Czechia
- VEGNI, A. M., University of Roma Tre, Italy
- VOLIOTIS, S., Technological Educational Institute of Chalkida, Greece
- VRBA, K., Brno Univ. of Technology, Czechia
- WIESER, V., University of Žilina, Slovakia
- WILFERT, O., Brno Univ. of Technology, Czechia
- WRULICH, M., Vienna University of Technology, Austria
- YANNOPOULOU, N., Democritus University of Thrace, Greece
- YO-SUNG, H., Gwangju Institute of Science and Technology, South Korea
- ZEZULA, R., Brno Univ. of Technology, Czechia
- ZOVKO-CIHLAR, B., University of Zagreb, Croatia
- ZVÁNOVEC, S., Czech Technical University in Prague, Czech