

JJT – 012 -2013

## BUCKLING ANALYSIS OF COMPOSITE DRIVE SHAFT FOR AUTOMOTIVE APPLICATIONS

*Madhu K.S.<sup>1</sup>, Darshan B.H.<sup>2</sup>, Manjunath K.<sup>3</sup>*

<sup>1&2</sup> PG Research Scholars, Department of Mechanical Engineering, GECH,KA, India

<sup>3</sup>Asst. Professor, Dept. of Mech. Engineering, GECH,KA, India

e-mail: madhuks.mce@gmail.com



### ABSTRACT

Automotive drive shaft is usually manufactured in two pieces in order to increase the fundamental bending natural frequency because it is inversely proportional to the square of beam length and proportional to the square root of specific modulus. Many research work have been carried out in this direction to replace two pieces drive shaft with single piece made of composites. This makes the single piece hollow shaft subjected to torsional load instability which is more critical in the design of composite shafts. In this context, a comprehensive approach to analyze the new composite drive shafts material is found to be essential. In this paper an attempt has been made to check the suitability of one piece composite drive shaft with various composite material combinations to fulfill the functional requirements. Firstly, a finite element model of composite drive shaft made of Steel SMC45, Kevlar49/Epoxy and HM Carbon Composite is developed to analyze for static, modal & buckling analysis. From the results obtained, it is observed that composites are having better shear strength and bending natural frequency compared to steel and Kevlar/Epoxy has good buckling strength capability as compared with other composites. These Finite element analysis results are compared with analytical values and observed that the single piece composite drive shaft is better suitable for driveline applications.

**Keywords**— Composite Drive Shaft, Finite element analysis, Shear Strength, Buckling Load

### INTRODUCTION

In the drive line application the torque produced in the engine has to be transferred to the rear wheels to move the vehicle. For realistic driveshaft system, improved lateral stability characteristics must be achieved together with improved torque carrying capabilities. In recent years research is

going on to replace a two piece drive shaft with a single piece shaft without sacrificing the functional requirements. As the single piece drive shaft is long and thin walled, the failure mode is torsional buckling rather than material failure. Bauchau and Krafchack [1] have measured the torsional buckling load of composite drive shafts made of carbon/epoxy and predicated the torsional buckling load using shell theory. Badie et al. [2] have performed a finite element analysis of carbon-epoxy and glass-epoxy drive shaft to investigate the effect of fibers winding and layer stacking sequence on the critical speed, buckling torque and fatigue resistance and also showed that shear strength is minor design importance in tube since the failure mode is dominated by buckling. Bert and Kim [3] have performed a theoretical analysis on torsional buckling of composite drive shafts and predicated the torsional buckling load of composite drive shafts with various lay-ups. Shokrieh et al. [5] have studied the effects of boundary conditions and the stacking sequence on the strength of the drive shaft.

Chowdhuri et al. [6] have presented a comprehensive approach to the design of automotive drive shaft considering basic requirements as torsional strength, torsional buckling and bending natural frequency.

Rangaswamy et al. [7] have proposed a design methodology for drive shaft of passenger vehicles by considering torsional transmission capability, bending natural frequency and buckling torque as design constraints and number of plies, stacking sequence and thickness of the play as design variables. Rasthogi [8] has presented a comprehensive approach to the design of composite drive shafts and developed the preliminary design tools for quick analysis to meet drive shaft performance requirements. Muthasher et al. [9] have investigated the effect of stacking

sequence angle on static and dynamic characteristic of the hybrid aluminum/composite drive. Manjunath et al. [4] have used particle swarm optimization technique to optimize the stacking sequence, number of layers and ply thickness to fulfil the functional requirement of drive shaft. In this paper, an attempt has been made to create finite element model of composite drive shaft [4] to analyze the suitability of one piece composite drive shaft to fulfil the functional requirements in terms of static, torsional buckling, and resonance point of view.

### PROBLEM DESCRIPTION

Generally the bending natural frequency of a shaft is inversely proportional to the square of the unsupported (beam) length and directly proportional to the square root of specific modulus. Therefore lesser the length of a shaft between supports, the overall weight of a single shaft will become less for a given material. Hence the conventional steel drive shafts (propeller shafts) of a commercial vehicle are usually made in two pieces, which leads to increased fundamental bending natural frequency. The drive shaft of a commercial vehicle made in two sections connected by a support structure, bearings and U-joints is shown in Figure 2.1

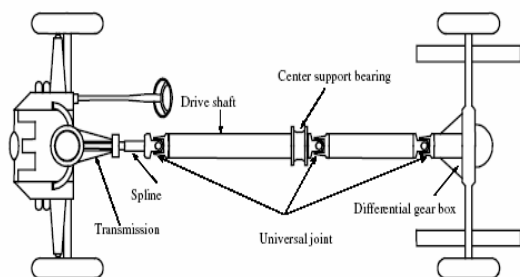

**Fig 2.1 Schematic Diagram of the Drive Shaft for a Rear Wheel Driving Vehicle**

However this construction increases the weight of the assembly due to the additional centre support bearings and other mountings. Together these parts need to be maintained and serviced regularly which adds for the maintenance cost. The problem can however be solved by replacing the conventional two piece steel drive shaft with single composite drive shaft which can full-fill the functionality of an automotive drive shaft without any weight

penalty, but for a composite driveshaft the prominent failure mode is shear buckling rather than material failure, which needs to be analyzed.

### DESIGN REQUIREMENT OF COMPOSITE DRIVE SHAFT

The objective for the optimum design of the composite drive shaft is the minimization of the weight, so the objective function of the problem is given as

$$m = \rho AL \text{ or } m = \rho \frac{\pi}{4} (d_o^2 - d_i^2) L \dots (1)$$

However this objective function is constrained by the functional requirements of the shaft, which are

- Static load carrying capability of the shaft :  $\sigma_d \geq \sigma_{max}$
- Bucking torque capacity of the shaft :  $T_{cr} \geq T_{max}$
- Fundamental natural frequency in bending :  $N_{cr} \geq N_{max}$

And the design parameters of the shaft for an automobile are given in table 3.1. The objective function is optimized by varying the stacking sequence, number of layers and lay thickness for different composite material using particle swarm optimization technique to meet the design requirement [4].

**Table 3.1 Design requirements of the shaft for an automobile [4]**

Parameters	Valules
Outer diameter $d_o$ (mm)	90
Length L(mm)	1250
Torque transmitted T(N-mm)	$3500 \times 10^3$
Speed of Transmission N(rpm)	6500

### ANALYTICAL RELATION TO CALCULATE THE CRITICAL LOAD OF COMPOSITE SHAFT

In the design of composite shafts before applying the finite element technique, a closed form solution is useful. In order to have an order-of-magnitude solution for a design, a simple equation is needed to calculate the torsional buckling load of long thin-wall shafts. There are various existing equations for this purpose in the literature. These equations are empirical, obtained based on experimental studies. The equation considered to find the buckling load is taken from reference [2].

$$T_{cr} = (2\pi r^2 t) * (0.272) * (E_x E_y^3)^{0.25} * (t/r)^{1.5} \dots (2)$$

Where, 'E<sub>x</sub>' and 'E<sub>y</sub>' are the Young's modulus of the composite shafts in axial and hoop direction 'r' and 't' are the mean radius and thickness of the composite drive shaft.

**FINITE ELEMENT ANALYSIS**

In this work, finite element model of steel and various composite drive shafts is developed for the optimized results obtained from particle swarm optimization [4] using ANSYS V 10 solver. The geometry and material properties of steel and composite drive shaft considered are shown in table 5.1 and 5.2 respectively. Since the geometry of the model is simple, an assumption of linear isotropic material for steel and linear orthotropic material for composites is made.

The element considered for modeling steel and composite shaft are shell 93 and shell 99 respectively. Each element is having 8 nodes and each node is having 6 degrees of freedom. The finite element model with load and boundary condition is shown in Figure 5.1.

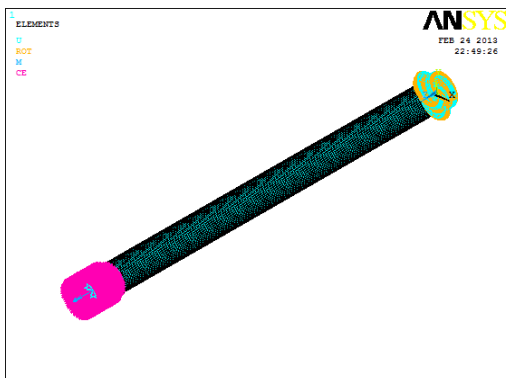

**Fig 5.1 Load and boundary conditions applied on the shaft**

**Table 5.1 Geometrical properties of various shafts [4]**

Parameter	Steel (SM45 C)	Kevlar49/ Epoxy	HM-Carbon/ Epoxy
Optimum Layers	-	16	17
Thickness t(mm)	3.32	6.8	2.04
Optimum Stacking sequence	-	[-46/73/39/50/-43/20/-24/-43/ $\overline{38}$ ] s	[-23/-51/68/-56/-72/47/-20/46/ $\overline{22}$ ] s
T (Nm)	3500	3500	3500

**Table 5.2 Material properties of various shafts [4]**

Material Parameter	Kevlar49/ Epoxy	HM-Carbon/ Epoxy
Ex (GPa)	21.0	37.49
Ey (GPa)	15.49	56.83
Gxy (GPa)	15.97	33.88
V12	0.35	0.39
Density (Kg/m3)	1500	1600

**Static Analysis**

For static analysis the shaft is fixed at one end and the other end a torque of  $3.5 \times 10^6$  N-mm is applied on rigid element (rbe3) created at center of shaft at a distance of 1150mm.

The Von Mises and shear stress distribution of various shafts are shown in figure 5.2 to 5.7.

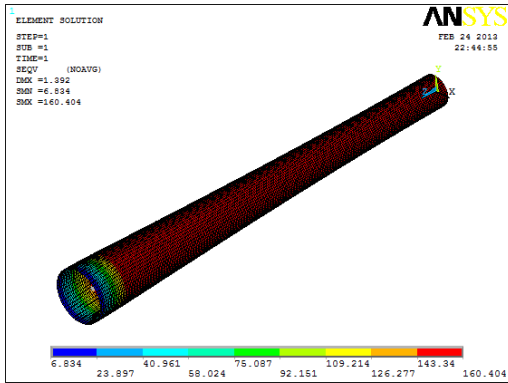

Fig 5.2 Von Mises Stress Distribution of Steel Drive Shaft

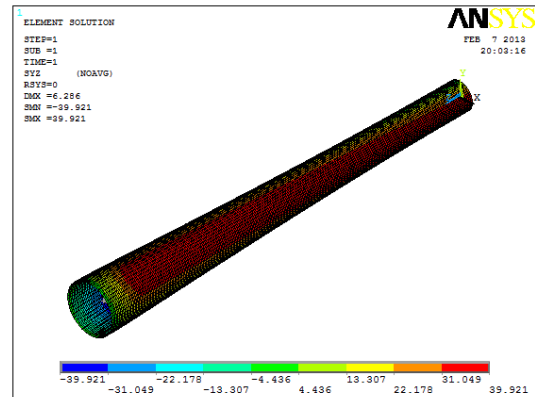

Fig 5.5 Shear Stress Distribution of Kevlar49/Epoxy Drive Shaft

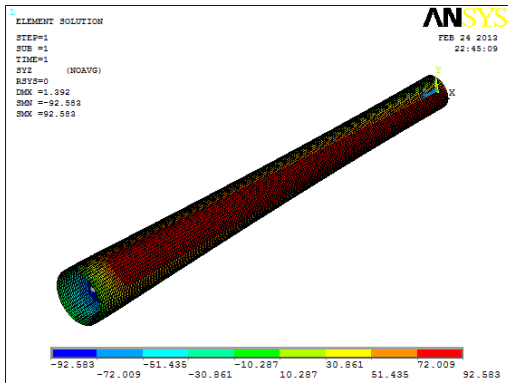

Fig 5.3 Shear Stress Distribution of Steel Drive Shaft

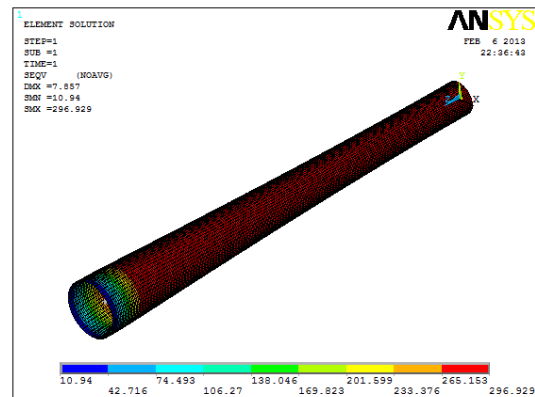

Fig 5.6 Von Mises Stress Distribution HM-Carbon/Epoxy Drive Shaft

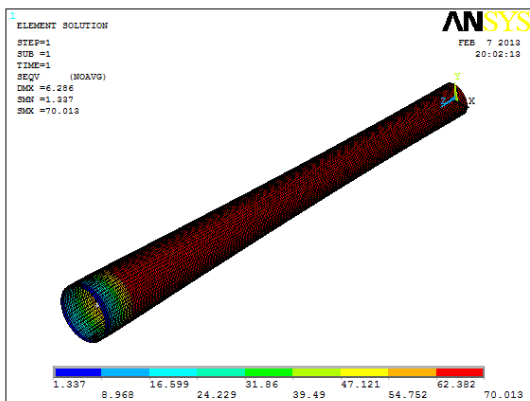

Fig 5.4 Von Mises Stress Distribution of Kevlar49/Epoxy Drive Shaft

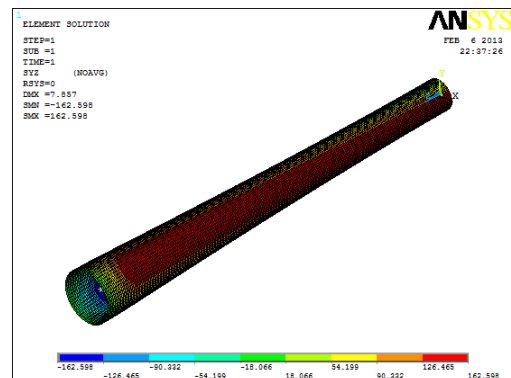

Fig 5.7 Shear Stress Distribution of HM-Carbon/Epoxy Drive Shaft

### Modal Analysis

Modal analysis deals with un-damped free vibration of a structure. It does not involve any computation of response due to any loading, but yields the natural frequencies and corresponding mode shapes. For Eigen value analysis the boundary conditions are assumed as pinned-pinned condition. The first mode shapes obtained for Steel, Kevlar49/ Epoxy and High Modulus Carbon/Epoxy materials using ANSYS V 10 are shown in figures 5.8 to 5.10 respectively. The frequencies of first modes are multiplied by 60 to obtain critical speeds of drive shaft.

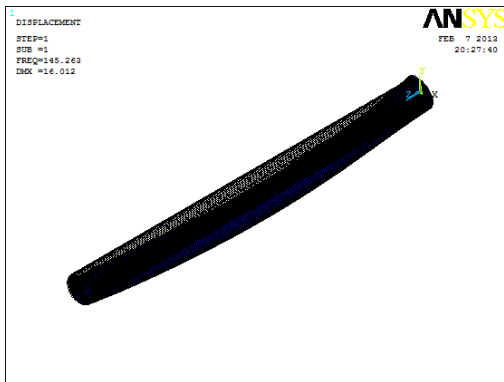

Fig 5.8 First Bending Mode of Steel Drive Shaft

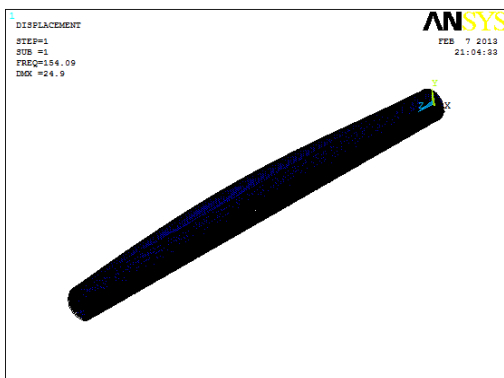

Fig 5.9 First Bending Mode Kevlar 49/Epoxy Drive Shaft

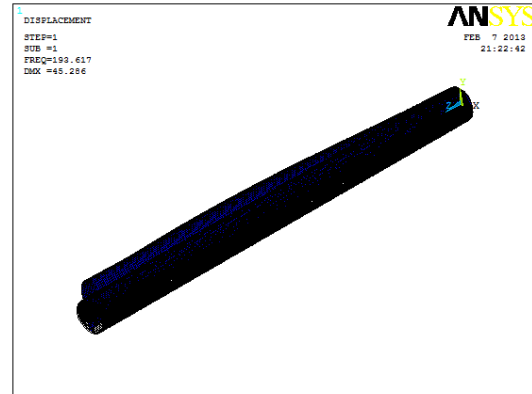

Fig 5.10 First Bending Mode Kevlar HM-Carbon/Epoxy Drive Shaft

### Buckling Analysis

Torsional buckling analysis is performed to get the critical torsional buckling load. The buckling frequency and its corresponding mode shapes obtained for Steel, Kevlar49/ Epoxy and High Modulus Carbon/Epoxy using ANSYS V 10 are shown in figures from 5.11 to 5.13.

The buckling strength is calculated by multiplying the critical speed with buckling load factor.

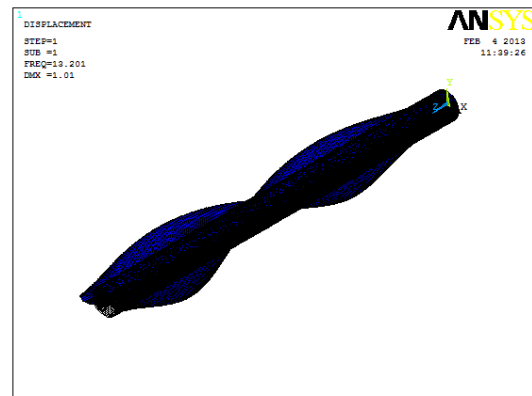

Fig 5.11 First Torsional Buckling Mode of Steel Drive Shaft

Table 6.2 Comparison of Von Mises stress

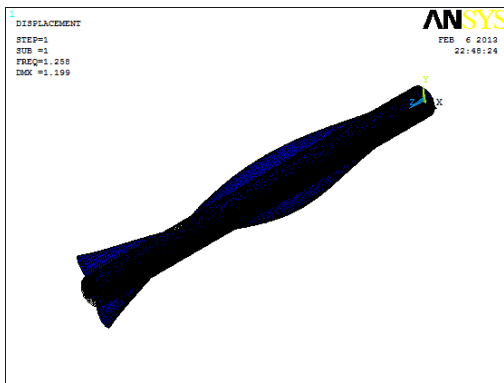

Fig 5.13 First Torsional Buckling Mode of HM-Carbon/Epoxy Drive Shaft

Material Stresses (Mpa)	Steel	Kevlar 49/ Epoxy	HM- Carbon/ Epoxy
Theoretical Vonmises stress	370	1400	1600
ANSYS Vonmises stress	160.40	70.01	296.92

## RESULT AND DISCUSSION

### Static Analysis of Steel and Composite Drive Shafts

The analysis is carried out with one end fixed and a torque of  $3.5 \times 10^6$  N-mm at other end. The shear and von mises stresses obtained from solver are compared with theoretical results and are tabulated in table 6.1 and 6.2 respectively. The shear strength is used to describe the strength of a shaft where the ductile material fails in shear. FEA solver results, shows that torque carrying capacity is more in Kevlar49/Epoxy composite shaft than conventional steel driveshaft. The steel and HM Carbon/Epoxy have lesser shear strength.

Table 6.1 Comparison of Shear strength

Material Stresses (Mpa)	Steel	Kevlar4 9/ Epoxy	HM- Carbon /Epoxy
Theoretical shear stress	175	461	396
ANSYS V10 Shear stress	92.58	39.92	162.59

### Modal Analysis of Steel and Composite Drive Shafts

The analysis is used to determine the natural frequencies and corresponding mode shapes to find the critical speed of the shaft. Using solver, first natural frequency and its mode shape is extracted as the first few natural frequencies are more critical and dominated to failure. The critical speed obtained from FE solvers for steel and, Kevlar49/Epoxy and HM Carbon/Epoxy composite material and calculated from PSO are tabulated and compared in Table 6.3.

It is observed that Kevlar49/Epoxy shafts have minimum amount of critical speed compared to the other material shafts. The critical speed depends upon the shaft

dimensions, materials and loads. In design optimization, the shaft dimensions and load are constant but stacking sequence is varied. As the critical speed depends upon stiffness

and density, the material having high stiffness value will have maximum critical speed. Finally it is evident from the table 6.3 that composite materials have more torque carrying capability. This clearly establishes the fact that torque capability of any material is reflected through critical speed values.

**Table 6.3 Comparison of critical speed**

<b>Critical Speed (rpm)</b> <b>Material</b>	PSO	ANSYS V 10
Steel	9320	8715
Kevlar49/ Epoxy	6533	9245
HM Carbon/ Epoxy	10197	11617

**Buckling Analysis of Steel and Composite Drive Shafts**

Buckling analysis predicts the theoretical buckling strength of an ideal elastic structure. It is the mathematical instability leading to a failure mode. Buckling loads are critical loads where the structures becomes unstable and each load has an associated with buckled mode shapes.

The critical buckled torque obtained from FE solvers for steel and Kevlar49/Epoxy and HM Carbon/Epoxy composite material are tabulated in table 6.4. The HM Carbon/Epoxy material have load factor around 1 and have very low critical buckling torque. It is observed that the buckling strength of the composite shafts is less compared to steel shaft of the same geometry because these properties depend on the stiffness and cross section of the material. It also depends upon the length to radius ratio (L/R), radius to thickness ratio (R/t) and unsupported length. Therefore, the composite shaft Kevlar49/Epoxy has higher critical buckling torque.

**Table 6.4 Buckling Analysis Results**

<b>Material</b>	Steel	Kevlar49/ Epoxy	HM-Carbon /Epoxy
Load factor	13.201	8.901	1.258
Torque obtained from ANSYS (Nm)	46203	31153	4403

**6.4 Validation**

Using Eq. (2) and data from table 3.1, 5.1 and 5.2 the theoretical buckling torque is calculated for kevlar49/Epoxy and HM Carbon/Epoxy.

For Kevlar49/Epoxy,  

$$T_{cr} = (2\pi * 41.6^2 * 6.8) * (0.272) * \{21.04 * 10^3 * (15.49 * 10^3)^3\}^{0.25} * (6.8/41.6)^{1.5}$$

$$= 22226 \text{ Nm}$$

For HM-Carbon/ Epoxy,

$$T_{cr} = (2\pi * 43.98^2 * 2.04) * (0.272) * \{37.49 * 10^3 * (56.83 * 10^3)^3\}^{0.25} * (2.04/43.98)^{1.5}$$

$$= 3450 \text{ Nm}$$

The FE and theoretical results are compared and tabulated in table 6.5. It is observed both results have good agreement with each other.

**Table 6.5 Comparison of buckling torque**

<b>Material</b>	Steel	Kevlar49/ Epoxy	HM-Carbon /Epoxy
Theoretical Buckling Torque (Nm)	45193	22226	3450
Torque obtained from ANSYS (Nm)	46203	31153	4403

**CONCLUSION**

When a long monolithic hollow composite driveshaft is subjected to torsional load, an instability occurs which is more critical in the design of composite drive shaft. The prominent failure mode of composite drive shaft is shear buckling rather than material failure. In this work an attempt is made to check the suitability of one piece composite drive shaft with various composite material combinations to fulfill the functional requirements. Firstly, a finite element model of composite drive shaft made of Steel SMC45, Kevlar49/Epoxy and HM Carbon Composite is

developed and analyzed for static, modal & buckling analysis using ANSYS 10.

Results clearly indicate that,

1. The optimized composite drive shafts designed using particle swarm optimization technique is safe under the peak torque loading of 3500Nm and rotational speed of 6500rpm.

2. The single piece steel drive shafts fail in shear.

3. Kevlar/Epoxy and HM Carbon/ Epoxy shafts are good in shear strength and bending natural frequency and are excellent from vibration point of view.

4. Kevlar/Epoxy has good buckling strength capability as compared with other composites.

The obtained Finite element analysis results are compared with analytical values and observed that the single piece composite drive shaft is better suitable for driveline applications. Thus the designed single piece composite drive shafts can be employed in the automobiles to result for considerable weight savings, thereby increasing the fuel efficiency. However, high material processing cost together with its limited availability is a major limitation of the composite materials which need to be addressed, to make the employment of composite driveshaft in the automobile economical.

## REFERENCES

1. Bauchau O A, Krafchack T M, Hayes J F, (1986) "Torsional Buckling Analysis and Damage Tolerance of Graphite/Epoxy Shafts", Journal of Comp Mat, vol; 17, pp 259-269.
2. Badie M A, Mahdi A, Abutalib A R, Abdullah E J, Yunus R, (2006) "Automotive Composite Drive shafts: Investigation of Design Variable Effects", International Journal of Engineering and Technology vol; 3, No.2, pp 227-237.
3. Bert CW, Kim CD, (1995) "Analysis of buckling hollow laminated composite drive shafts", Compos Sci Technol;53:343–51.

4. Manjunath K, Mohan Kumar S, and Channakeshava K.R., (2010) "Ply Stacking Sequence Optimization of Composite Driveshaft using Particle Swarm Optimization Algorithm" International Journal of Mechanical Engineering & Technology (IJMET), Vol. 1, No. 1, pp. 74–93.

5. Mahmood Shokrieh M., and Hasani, A., (2004), "Study of Shear Buckling of Composite Shafts under Torsion," Composite Structures, Vol. 64/1, pp. 63-69.

6. M.A.K. Chowdhuri and R.A. Hossain, (2010) "Design Analysis of an Automotive Composite Drive Shaft" International Journal of Engineering and Technology Vol.2 No.2, pp. 45-48.

7. Rangaswamy T, Vijayarangan S, (2005) "Optimal Sizing and Stacking Sequence of Composite Driveshaft", ISSN 1392-1320 Materials Science and Engineering, Vol; 11, No.2, pp133-140.

8. Rastogi N, (2004) "Design of composite drive shafts for automotive applications", SAE, technical paper series, 2004-01 0485.

9. S A Mutasher, B B Sahari, A M S Hamouda and S M Sapuan, (2007) "Static and Dynamic Characteristics of a Hybrid Aluminum/Composite Drive Shaft", Proceedings of the Institution of Mechanical Engineers, Part L: Journal of Materials: Design and Applications, Vol. 221, No. 2, pp. 63-75.



A Point Clicks an Idea