

## Sampling soil-derived CO<sub>2</sub> for analysis of isotopic composition: a comparison of different techniques

TERESA BERTOLINI\*†‡, ILARIA INGLIMA†, MAURO RUBINO‡, FABIO MARZAIOLI†, CARMINE LUBRITTO†, JENS-ARNE SUBKE§, ALESSANDRO PERESSOTTI¶ and M. FRANCESCA COTRUFO†

†Department of Environmental Sciences, Second University of Naples, Via Vivaldi 43, 81100 Caserta, Italy

‡CNR-ISA FoM, Via Patacca 85, 80056 Ercolano, Italy

§Department of Biology, University of York, York YO10 5DD, UK

¶Department of Crop Science and Agricultural Engineering, University of Udine, Via delle Scienze 208, 33100 Udine, Italy

(Received 7 January 2005; in final form 11 November 2005)

A new system for soil respiration measurement [P. Rochette, L.B. Flanagan, E.G. Gregorich. Separating soil respiration into plant and soil components using analyses of the natural abundance of carbon-13. *Soil Sci. Soc. Am. J.*, **63**, 1207–1213 (1999).] was modified in order to collect soil-derived CO<sub>2</sub> for stable isotope analysis. The aim of this study was to assess the suitability of this modified soil respiration system to determine the isotopic composition ( $\delta^{13}\text{C}$ ) of soil CO<sub>2</sub> efflux and to measure, at the same time, the soil CO<sub>2</sub> efflux rate, with the further advantage of collecting only one air sample. A comparison between different methods of air collection from the soil was carried out in a laboratory experiment. Our system, as well as the other dynamic chamber approach tested, appeared to sample the soil CO<sub>2</sub>, which is enriched with respect to the soil CO<sub>2</sub> efflux, probably because of a mass dependent fractionation during diffusion and because of the atmospheric contribution in the upper soil layer. On the contrary, the static accumulation of CO<sub>2</sub> into the chamber headspace allows sampling of  $\delta^{13}\text{C}$ -CO<sub>2</sub> of soil CO<sub>2</sub> efflux.

*Keywords:* Carbon-13; Carbon dioxide; Measurement; Respiration; Sampling; Soil

### 1. Introduction

Carbon isotopes are widely used to understand carbon dynamics in soils as well as to disentangle the soil respiration into root and microbial contributions [1–6]. Flux-based measurements allow to quantify the behaviour and shifts in the components of below-ground C balance as well as to put boundaries on the environmental conditions responsible for the observed changes. Isotope-based measurements permit to identify the contribution of the sources (*e.g.*, autotrophic *vs.* heterotrophic) of the C-fluxes linking plant and microbial function to the

---

\*Corresponding author. Tel.: +39-082-327-4511; Fax: +39-082-327-4605; Email: teresa.bertolini@unina2.it

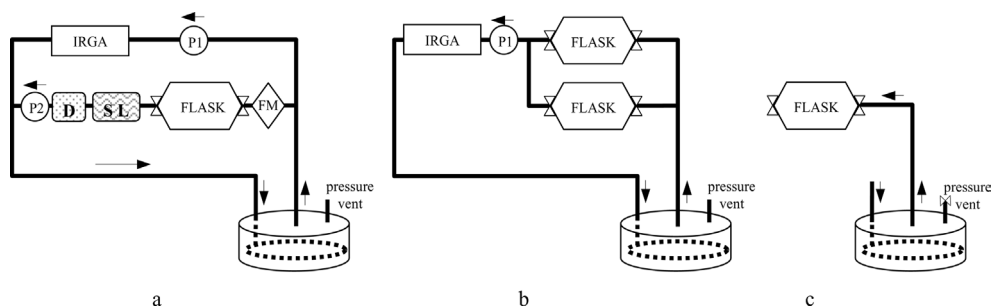

Figure 1. (a) CC chamber system scheme. Air is drawn from the cylindrical chamber headspace (25 cm OD, 5 cm height) and enters the chamber through a circular manifold located 1 cm above the lower edge of the chamber. To prevent pressurizing the chamber space with respect to the ambient atmosphere, a vent (2 mm diameter) with 10 cm of tubing (4 mm ID) was included. A 21 flask was placed before the scrubbers. Arrows indicate direction of air flow. (b) Dynamic close system (MB 2). (c) Static close system (MB 1).

observed fluxes. Accurate measurements of root and soil organic matter respiration are essential in ecological studies of terrestrial carbon budgets, from the ecosystem to the global scale, because the annual flux of  $\text{CO}_2$  from soils to the atmosphere is 10 times higher than that derived from fossil fuel combustion [7], and it is susceptible to increase in response to climatic changes [8].

Previous studies [9–11] defined the ‘soil-respired  $\text{CO}_2$ ’ as the  $\text{CO}_2$  coming off the soil, thus reflecting the  $\delta^{13}\text{C}\text{-CO}_2$  coming from the decomposition of the organic substrates, which represent the  $\text{CO}_2$  of the source. In contrast, the ‘soil  $\text{CO}_2$ ’, which indicates the  $\text{CO}_2$  that fills the soil pore air space, is enriched in  $^{13}\text{C}\text{CO}_2$  by a theoretical minimum of 4.4‰, with respect to the respired  $\delta^{13}\text{C}\text{-CO}_2$  [12], because of the isotopic fractionation derived from a mass dependent diffusion effect at the steady state. Furthermore, in the upper layers of the soil profile, there is a further enrichment because of the atmospheric contribution, which depends on the efflux rate and the soil porosity. Amundson *et al.* [11] suggested a theoretical model to describe the vertical soil profile of  $\text{CO}_2$  isotopic composition ( $\delta^{13}\text{C}\text{-CO}_2$ ), taking into account all of these issues.

There is no unique method to measure the  $\delta^{13}\text{C}\text{-CO}_2$  of the soil efflux [13–15], although the Keeling plot model is one of the most frequently used. However, as it requires a large number of samples for each measurement, it is not suitable for sampling the variability in space and time in the field. The aim of this study was to obtain a method for the measurement of  $\delta^{13}\text{C}\text{-CO}_2$  of soil efflux, employing equipment that is reliable and portable in the field, and that allows simultaneous determination of  $\text{CO}_2$  soil efflux and of its isotopic composition, with a very limited number of air samples to analyse. For this purpose, the constant concentration (CC) system, previously described by Subke *et al.* [16], was implemented for collection of soil-derived  $\text{CO}_2$  (figure 1a). We hypothesized that the soil  $\text{CO}_2$  efflux sampling, by the modified CC system, does not affect the soil  $\text{CO}_2$  profile and thus captures the ‘soil-respired  $\text{CO}_2$ ’. A comparison between different sampling setups was performed to assess this hypothesis. At the same time, all the inputs to simulate the  $\delta^{13}\text{C}\text{-CO}_2$  of the soil vertical profile were measured.

## 2. Materials and methods

### 2.1 Experimental setup

A large gardening pot (40 cm at base, 50 cm at the top) was filled to a depth of 35 cm with well-mixed mineral soil and fresh gardening compost. A collar (12 cm high and 25 cm OD) was

positioned inside the pot with about 6 cm insertion depth and connected to a soil respiration chamber, on which the tube pathway was changed according to the different setups used for soil CO<sub>2</sub> sampling (discussed subsequently). The air mixing into the chamber headspace is ensured by a ring-shaped air inlet and the pump flow (adjustable in a range of about 200–800 ml min<sup>-1</sup>). All the sampling procedures were replicated randomly at least three times and were performed as follows.

## 2.2 CC system

The CC method gives reliable respiration rate measurements at the steady state by keeping the concentration within the chamber headspace at ambient CO<sub>2</sub> level [16]. A soil CO<sub>2</sub> efflux measurement is obtained by regulating the pump speed ( $P_2$ ) and thus the air volume flow across the CO<sub>2</sub> absorber, so that the CO<sub>2</sub> concentration inside the chamber remains constant at ambient levels. At this equilibrium state, the amount of CO<sub>2</sub> entering the chamber from the soil is balanced by the amount of CO<sub>2</sub> absorbed by sodalime, and the soil CO<sub>2</sub> efflux rate ( $\mu\text{mol m}^{-2} \text{s}^{-1}$ ) can be calculated as  $F_s C_i A^{-1}$ , where  $F_s$  is the mass flow ( $\text{mol s}^{-1}$ ) across sodalime,  $C_i$  the CO<sub>2</sub> concentration ( $\mu\text{mol mol}^{-1}$ ) and  $A$  the chamber area ( $\text{m}^2$ ).

A CC system, previously described by Subke *et al.* [16], was modified for collection of soil-derived CO<sub>2</sub> into a 2 l flask, which was placed before the CO<sub>2</sub> and H<sub>2</sub>O scrubbers (figure 1a), to subsequently measure the  $\delta^{13}\text{C}$ -CO<sub>2</sub> off-line, by collecting only one flask. The 2 l flasks were Pyrex<sup>®</sup> made and sealed with two Rotaflo<sup>®</sup> stopcocks (Bibby Sterilin, UK) certified for a vacuum level of  $10^{-6}$  mbar and a vacuum leakage rate in the order of  $10^{-9}$  mbar l s<sup>-1</sup> at 20 °C.

Depending on the soil CO<sub>2</sub> efflux rate, the system volume (including every part of the sampling path) and the ambient CO<sub>2</sub> concentration, a simple mixing model can be used to calculate for how long the internal volume of air needs flushing through the system to substitute 99% of the atmospheric CO<sub>2</sub> with soil-derived CO<sub>2</sub> in the close system. During this experiment, the soil efflux ranged between 1.91 and 2.98  $\mu\text{mol m}^{-2} \text{s}^{-1}$ , thus the time required to substitute the initial air in the overall system volume ranged between 50 and 60 min (table 1), whereas the air residence time into the chamber headspace ranged between 6 and 8 min.

## 2.3 Static accumulation system

This setup is very simple, requiring only one connection between the chamber headspace and a flask, which needs to be previously evacuated to high vacuum (figure 1c). In a closed static mode (MB 1), a 2 l vacuum flask was collected after 40 min of CO<sub>2</sub> accumulation in the chamber headspace. At the same time, a second 2 l vacuum flask was collected for the

Table 1. Main characteristics of each sampling method used.

Method	CC	MB 1	MB 2
Soil boundary layer <sup>†</sup>	Yes	No	Yes
Steady state <sup>‡</sup>	Yes	No	No
Air recirculation	Yes	No	Yes
Sampling interval	50–60 min	40 min	5–15 min
$\Delta[\text{CO}_2]$ ( $\mu\text{mol mol}^{-1}$ )	0	> 500	> 100
Flask conditioning	Ambient air	Evacuated	Nitrogen
Number of air samples	1	2	2

<sup>†</sup>The soil boundary layer implies a dynamic behaviour within the chamber headspace.

<sup>‡</sup>The steady state implies a constant CO<sub>2</sub> concentration and a constant flow through the chamber headspace during the sampling interval.

measurement of the  $\delta^{13}\text{C-CO}_2$  of ambient air. The mass balance approach is referred to the atmospheric background, with the second flask sampling air just outside the chamber. It is worth noting that this is not a Keeling plot type model [14], but a simple two-end member mass balance. In other words, the second collected flask has an isotopic composition ( $\delta^{13}\text{C}_2$ ) due to the initial  $\delta^{13}\text{C-CO}_2$  plus the soil-derived  $\text{CO}_2$  ( $\delta^{13}\text{C}_{\text{in}}$ ), and the latter can be calculated as follows:

$$\delta^{13}\text{C}_{\text{in}} = \frac{\delta^{13}\text{C}_2[\text{CO}_2]_2 - \delta^{13}\text{C}_1[\text{CO}_2]_1}{[\text{CO}_2]_2 - [\text{CO}_2]_1} \quad (1)$$

## 2.4 Close dynamic system

In a closed dynamic system (MB 2, figure 1b), the soil-derived  $\text{CO}_2$  was circulated from the chamber through two nitrogen preconditioned 2 l flasks, in parallel, and an infrared gas analyser, IRGA (Li-Cor 840, Li-Cor, Inc., Lincoln, Nebraska, USA) [14, 15] with a residence time in the chamber headspace of about 5 min. Following are the operational steps: (1) connect the MB 2 system to the chamber; (2) open the stopcocks to both  $\text{N}_2$  conditioned flasks; (3) place the chamber onto the collar and immediately begin air circulation from the chamber through both flasks and IRGA; (3) wait for a period of time to allow circulation to evenly mix the  $\text{CO}_2$ -free air from the two flasks with the chamber air; (4) once the air is evenly mixed by observing the damping of  $\text{CO}_2$  fluctuations on the Licor, close off the stopcocks to flask 1 to take the first sample at about ambient  $\text{CO}_2$  concentration; (5) wait for a period of time to allow an additional amount of  $\text{CO}_2$  to accumulate in the sampling volume (table 1); and (6) close off the stopcocks to flask 2 to take the second sample.

In this case, the mass balance is not considering the atmospheric background but just the first air sample, which has, at ambient  $\text{CO}_2$  concentration, a different isotopic composition due to the dilution with the nitrogen of the initial air into the chamber headspace and to the contribution from the soil-derived  $\text{CO}_2$ , and the equation we used is the same as for MB 1.

## 2.5 Sampling for determination of $\delta^{13}\text{C-CO}_2$ of soil air and of $\text{CO}_2$ source

The soil  $\delta^{13}\text{C-CO}_2$  was obtained by probe sampling of soil  $\text{CO}_2$ . The probe, inserted within the soil to a depth of about 20 cm, was connected to a nitrogen filled 2 l flask, equilibrated for a week with the soil  $\text{CO}_2$  by diffusion.

The isotopic composition of the source material was determined by incubation over 2 days in 1 l glass jars [13] of soil subsamples, in five replicates. Each of the five soil subsamples was taken from the pot in the five subsequent days over which the experiment took place. An amount of 100 g of soil was collected from the pot and incubated in an air-tight jar. The air inside jars was then flushed through sodalime until it reached 0 ppm of  $\text{CO}_2$ , checked by the IRGA. Jars were kept closed in the dark at the same temperature of the soil pot (which ranged from 22 to 23 °C) for 2 days and then directly connected to a cryogenic line for the  $\text{CO}_2$  purification [17]; a sodalime-filled tube was connected to the jar to keep the pressure in the jar at atmospheric level.

## 2.6 Measurement of $\text{CO}_2$ concentrations and $\delta^{13}\text{C-CO}_2$

The  $\text{CO}_2$  concentration of the air sampled in vacuum flasks was determined barometrically by the pressure gauge in the isotope ratio mass spectrometry (IRMS Delta<sup>plus</sup>, Thermofinnigan, Germany) variable-volume bellow calibrated with different amounts of cryogenically purified

CO<sub>2</sub> from known CO<sub>2</sub> concentration air samples, with an uncertainty of 22 μmol mol<sup>-1</sup>. For the MB 2 and CC setups, CO<sub>2</sub> concentrations were measured by the IRGA.

From each flask, the CO<sub>2</sub> was concentrated via cryogenic purification and the δ<sup>13</sup>C<sub>PDB</sub> was determined by stable IRMS, which for δ<sup>13</sup>C<sub>PDB</sub> has a precision of 0.04 ‰ (because of the uncertainty introduced by the use of solid copper for the reduction of N<sub>2</sub>O to N<sub>2</sub> at 500 °C) and an accuracy of 0.09 ‰ [17]. A cylinder of CO<sub>2</sub> in air certificated from CSIRO Atmospheric Research (Aspendale, Australia), was cryogenized and analysed among samples for data quality control.

## 2.7 Soil δ<sup>13</sup>C-CO<sub>2</sub> vertical profile model

We adapted the model of Amundson *et al.* [11] to our study case, measuring all the input variables to assess the results obtained by the different sampling techniques. We assumed the same diffusion coefficient as for CO<sub>2</sub> diffusion in air, and for <sup>13</sup>CO<sub>2</sub> diffusion coefficient, we took into account the theoretical difference of 4.4 ‰. Thus, the soil δ<sup>13</sup>C-CO<sub>2</sub> vertical profile was simulated to derive δ<sup>13</sup>C-CO<sub>2</sub> of soil CO<sub>2</sub> efflux and of CO<sub>2</sub> source, and the results were compared with those obtained by the experimental soil chamber samplings described earlier. As model input, the soil efflux rate derived from the CC measurement, the source δ<sup>13</sup>C-CO<sub>2</sub> derived from the jar incubation and the atmospheric δ<sup>13</sup>C-CO<sub>2</sub> from the MB 1 outside chamber flask collection were used (figure 2).

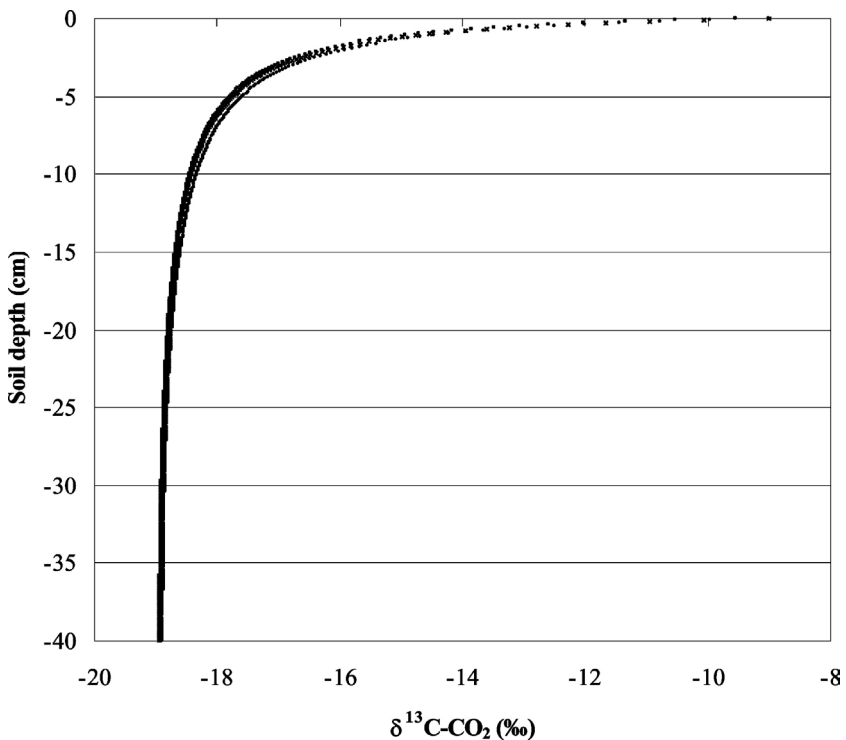

Figure 2. Modelled δ<sup>13</sup>C-CO<sub>2</sub> vertical profile in the pot, for the three replicated samplings by the CC system. Adapted from Amundson *et al.* [11].

### 3. Results and discussions

The CC setup and the MB 2 approach measure  $\delta^{13}\text{C-CO}_2$  values of  $-18.56\text{‰}$  ( $\pm 0.40\text{‰}$ ) and  $-18.35\text{‰}$  ( $\pm 0.40\text{‰}$ ), respectively, which are similar to the  $\delta^{13}\text{C-CO}_2$  value of the ‘soil  $\text{CO}_2$ ’ as measured by the soil probe, despite fundamentally different sampling pathways and intervals (figure 3 and table 2). In contrast, the MB 1 approach measures a  $\delta^{13}\text{C-CO}_2$  value of  $-24.25\text{‰}$  ( $\pm 2.1\text{‰}$ ), which is consistent with the  $\delta^{13}\text{C-CO}_2$  value of  $-23.69\text{‰}$  ( $\pm 0.27\text{‰}$ ) of the soil  $\text{CO}_2$  source, as measured from the jar incubation, but with significantly higher uncertainty when compared with the other methods (figure 3). A large part of the uncertainty associated with this method is due to the necessity of having very precise  $\text{CO}_2$  concentration measurements and a larger number of samples. However, the strong disturbance of the soil profile, due to the high concentration reached inside the chamber, does not seem to be critical for the measurement of the  $\delta^{13}\text{C-CO}_2$  soil efflux. Judging from the results of this experiment, the accumulation in the chamber headspace appears to eliminate the mass dependent diffusion effect occurring during soil respiration due to the large amount of  $\text{CO}_2$  coming from the source. Additionally, the MB 1 technique takes into account the atmospheric contribution.

The soil  $\delta^{13}\text{C-CO}_2$  similarity obtained with the two dynamic methods (*i.e.*, CC  $-18.56 \pm 0.40\text{‰}$  SD and MB 2  $-18.35 \pm 0.40\text{‰}$  SD) supports the idea that they are not sampling the isotopic composition of the source, but rather of soil air, which carries a very similar  $\delta^{13}\text{C-CO}_2$  signal ( $-19.4 \pm 0.15\text{‰}$  SD). A possible explanation could be that the soil chamber equilibrates with the pore air at the insertion depth, thus a horizontal  $^{13}\text{C-CO}_2$  flux exchange establishes because of the mixing of the atmospheric  $^{13}\text{CO}_2$  near the soil surface [11]. For that reason, the CC and MB 2 systems result in the collection of air samples composed of a mixture of source  $\text{CO}_2$  and atmospheric  $\text{CO}_2$ . Nevertheless, the  $\delta^{13}\text{C-CO}_2$  efflux values can be estimated from MB 2 and CC data using the model of Amundson *et al.* [11], to simulate the atmospheric contribution to the soil  $\text{CO}_2$  at the collar insertion depth (figure 2). Indeed, a good agreement was obtained between the mean of the modelled values ( $-23.97 \pm 0.82\text{‰}$  SD) and the jar incubation mean ( $-23.69 \pm 0.27\text{‰}$  SD).

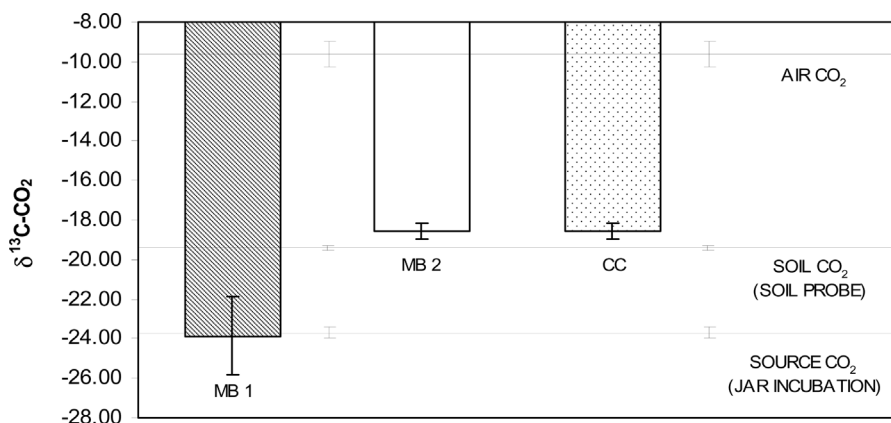

Figure 3.  $\delta^{13}\text{C-CO}_2$  measured from air samples collected with different setups. Error bars are standard deviations.

Table 2. Raw data of the three different setups; six replicates for the CC and three replicates for MB 1 and MB 2.

CC		MB 1			MB 2				
[CO <sub>2</sub> ] (μmol mol <sup>-1</sup> †)	δ <sup>13</sup> C-CO <sub>2</sub> (μmol mol <sup>-1</sup> ‡)	[CO <sub>2</sub> ] (μmol mol <sup>-1</sup> ‡)	[CO <sub>2</sub> ] (μmol mol <sup>-1</sup> ‡)	[CO <sub>2</sub> ] (μmol mol <sup>-1</sup> ‡)	[CO <sub>2</sub> ] (μmol mol <sup>-1</sup> ‡)	[CO <sub>2</sub> ] (μmol mol <sup>-1</sup> ‡)	δ <sup>13</sup> C-CO <sub>2</sub> (μmol mol <sup>-1</sup> ‡)	δ <sup>13</sup> C-CO <sub>2</sub> (μmol mol <sup>-1</sup> ‡)	δ <sup>13</sup> C-CO <sub>2</sub> (μmol mol <sup>-1</sup> ‡)
480	-18.6	430	907	907	397	587	-10.26	-17.03	-16.72
410	-18.52	460	946	946	417	541	-9.57	-16.46	-16.26
410	-18.56	460	946	946	417	541	-9.57	-16.46	-16.26
472	-18.387	460	946	946	417	541	-9.57	-16.46	-16.26
495	-19.282	460	737	737	391	607	-9.00	-15.66	-14.76
405	-18.042	460	737	737	391	607	-9.00	-15.66	-14.76

† ± 1 μmol mol<sup>-1</sup> SD.

‡ ± 22 μmol mol<sup>-1</sup> SD.

#### 4. Conclusions

This experiment indicates that the methodological approaches which proved to give the most reliable determination of soil CO<sub>2</sub> efflux rate (*i.e.*, no disruption of soil CO<sub>2</sub> vertical gradient, air mixing within the chamber headspace [18]) are not necessarily the best methods to determine the  $\delta^{13}\text{C-CO}_2$  of the soil efflux source. In fact, the CC appears to act as a large air-filled soil pore in equilibrium with the soil  $\delta^{13}\text{C-CO}_2$  at the collar insertion depth, because of the replacement within the chamber of atmospheric CO<sub>2</sub> with soil-derived CO<sub>2</sub>, removing the undisturbed <sup>13</sup>CO<sub>2</sub> gradient. We interpret this result suggesting that our CC system samples soil CO<sub>2</sub> for reproducible measurements of  $\delta^{13}\text{C-CO}_2$  (0.4% SD), at the collar insertion depth, and that  $\delta^{13}\text{C-CO}_2$  of soil efflux can be derived by applying a soil diffusion model [11].

Infrared laser spectroscopy, with tuneable diode laser (TDL), has reached a level of precision and accuracy for measurements at ambient CO<sub>2</sub> concentration, which are comparable to the sampling techniques relying on IRMS [19]. TDL measurements require less than 3 l of sample air and produce results within 10 min and would therefore provide a valuable improvement of these soil air sampling techniques. At present, measurements are limited by the small number of samples that can be obtained using sampling flasks and the time needed for analysis, both of which would be considerably improved if a TDL could be used on-line. Such a setup would open new investigation possibilities for isotopic composition of sources at natural abundance in a number of terrestrial ecosystems, where, at present, uncertainties due to large standard errors caused by the limited number of samples obtained prohibit the detection of significant differences between source contributions.

#### Acknowledgements

The work was financially supported by the European Commission through the MIND project, by the Italian MIUR through the Interlink programme and by the Regione Campania (Italy) through the INNOVA project.

#### References

- [1] P. Rochette, L.B. Flanagan, E.G. Gregorich. Separating soil respiration into plant and soil components using analyses of the natural abundance of carbon-13. *Soil Sci. Soc. Am. J.*, **63**, 1207–1213 (1999).
- [2] H.P. Collins, E.T. Elliot, K. Paustian, L.G. Bundy, W.A. Dick, D.R. Huggins, A.J.M. Smucker, E.A. Paul. Soil carbon pools and fluxes in long-term corn belt agroecosystems. *Soil Biol. Biochem.*, **32**, 157–168 (2000).
- [3] P.J. Hanson, N.T. Edwards, C.T. Garten, J.A. Andrews. Separating root and soil microbial contribution to soil respiration: a review of methods and observations. *Biogeochemistry*, **48**, 115–146 (2000).
- [4] J.R. Ehleringer, N. Buchmann, L.B. Flanagan. Carbon isotope ratios in belowground carbon cycle processes. *Ecol. Appl.*, **10**, 412–422 (2000).
- [5] S. Trumbore. Age of soil organic matter and soil respiration: radiocarbon constraints on belowground C dynamics. *Ecol. Appl.*, **10**, 399–411 (2000).
- [6] A. Ekblad, P. Högberg. Natural abundance of <sup>13</sup>C in CO<sub>2</sub> respired from forest soils reveals speed of link between tree photosynthesis and root respiration. *Oecologia*, **127**, 305–308 (2001).
- [7] W.H. Schlesinger. *Biogeochemistry: An Analysis of Global Change*. 2<sup>nd</sup> Edition, Academic Press, San Diego (1997).
- [8] P.M. Cox, R.A. Betts, C.D. Jones, S.A. Spall, I.J. Totterdell. Acceleration of global warming due to carbon-cycle feedbacks in a coupled climate model. *Nature*, **408**, 184–187 (2001).
- [9] H. Dörr, K.O. Münich. Carbon-14 and carbon-13 in soil CO<sub>2</sub>. *Radiocarbon*, **22**, 909–918 (1980).
- [10] T.E. Cerling. The stable isotopic composition of modern soil carbonate and its relationship to climate. *Earth Planet. Sci. Lett.*, **71**, 229–240 (1984).
- [11] A. Amundson, L. Stern, T. Baisden, Y. Wang. The isotopic composition of soil and soil-respired CO<sub>2</sub>. *Geoderma*, **82**, 83–114 (1998).
- [12] T.E. Cerling, D.K. Solomon, J. Quade, J.R. Bowman. On the isotopic composition of carbon in soil carbon dioxide. *Geochim. Cosmochim. Acta*, **55**, 3403–3405 (1991).



- [13] J.A. Andrews, K.G. Harrison, R. Matamala, W.H. Schlesinger. Separation of root respiration from total soil respiration using carbon-13 labeling during free-air carbon dioxide enrichment (FACE). *Soil Sci. Soc. Am. J.*, **63**, 1429–1435 (1999).
- [14] N. Buchmann, T.M. Hinckley, J.R. Ehleringer. Carbon isotope dynamics in *Abies amabilis* stands in the Cascades. *Can. J. Forest Res.*, **28**, 808–819 (1998).
- [15] J.E. Fessenden, J.R. Ehleringer. Age-related variations in  $\delta^{13}\text{C}$  of ecosystem respiration across a coniferous forest chronosequence in the Pacific Northwest. *Tree Physiol.*, **22**, 159–167 (2002).
- [16] J.A. Subke, I. Inglima, A. Peressotti, G. Delle Vedove, M.F. Cotrufo. A new technique to measure soil CO<sub>2</sub> efflux at constant CO<sub>2</sub> concentration. *Soil Biol. Biochem.*, **36**, 1013–1015 (2004).
- [17] T. Bertolini, M. Rubino, C. Lubritto, A. D’Onofrio, F. Marzaioli, I. Passariello, F. Terrasi. Optimized sample preparation for isotopic analyses of CO<sub>2</sub> in air: systematic study of precision and accuracy dependence on driving variables during CO<sub>2</sub> purification process. *J. Mass Spectrom.*, **40**, 1104–1108 (2005).
- [18] J. Pumpanen, P. Kolari, H. Ilvesniemi, K. Minkkinen, T. Vesala, S. Niinistö, A. Lohila, T. Larmola, M. Morero, M. Pihlatie, I. Janssens, J.C. Yuste, J.M. Grünzweig, S. Reth, J.-A. Subke, K. Savage, W. Kutsch, G. Oestreg, W. Ziegler, P. Anthoni, A. Lindroth, P. Hari. Comparison of different chamber techniques for measuring soil CO<sub>2</sub> efflux. *Agr. Forest Meteorol.*, **123**, 159–176 (2004).
- [19] J.B. McManus, M.S. Zhaniser, D.D. Nelson, L.R. Williams, C.E. Kolb. Infrared laser spectrometer with balanced absorption of isotopic ratios of carbon gases. *Spectrochim. Acta A*, **58**, 2465–2479 (2002).

