

# Hybrid Vehicle: A Study on Technology

Karan C. Prajapati <sup>1,\*</sup>, Ravi Patel <sup>2</sup> and Rachit Sagar <sup>3</sup>

1, 2, 3: B.Tech (Mechanical Engineering) Student,

Department of Mechanical Engineering,

School of Technology, Pandit Deendayal Petroleum University

Raisan, Gandhinagar, Gujarat - 382007, India

**Abstract:** With the advancement in 21st Century, there has been increase in usage of Oil and Gas leading to problems like Global Warming, climate change, shortage of crude oil, etc. Due to these reasons Automobile Companies have started doing research for making Hybrid Technology usable into the daily life. The Paper starts from brief history about Hybrid Technology and also some brief introduction on it. Paper will also discuss the technologies used in the making of Hybrid Cars such as “Hybrid Solar Vehicle”, “Hybrid Electric Vehicle” and “Plug In hybrid electric vehicles”. Our Paper is based on the explanation of such technologies, their function, drawback of this technology, efficiency of Hybrid Cars, Case studies on the present commercial hybrid cars such as Toyota Prius series, Astrolab etc and the fuels and raw materials used in the Hybrid Cars. Paper concludes on the advantages and dis-advantages of Hybrid Cars and how this technology will take over the world in future and would become the alternative for Petrol and Diesel Cars.

**Keywords** - hybrid electric vehicle; hybrid solar vehicle; plug in hybrid electric vehicle; Toyota Prius series

## I. INTRODUCTION

With the invention of Internal Combustion Engine by Nicolas Otto, there was revolution in Automobile field. Later on, Petrol and Diesel became the main source of fuel for these vehicles. This technology made Human Efforts very easy through commercializing in the market. As, the world went through 20<sup>th</sup> Century, there happened many advancements for making this technology efficient and cost-effective. Due, to which it became the commercial success and its use in the day to day period increased. People could reach thousands of kilometres/miles in hours with the help of this technology. As we know everything has its own positive and negative side. The rate of Carbon Monoxide (CO) and Carbon Dioxide (CO<sub>2</sub>) suddenly increased at the dangerous level in the beginning of 21<sup>st</sup> Century which made a negative impact on Ecosystem, reason for Global Warming, Health related issues, etc. This forced Scientist, Researchers and Policymakers to focus or made them start thinking for Green Technology or the technology which can stop the adverse effect happening on Nature. Hence, the 21<sup>st</sup> Century will become the Century for Evolution in various technologies with the main focus in Automobile Sector.

The technologies which will change the face of Automobile Sector would be “Hybrid Electric Vehicle”, “Hybrid Solar Vehicle”, “Hydrogen Fuel Cell”, etc. From all this Hybrid Electric Vehicle is considered as the most industrially matured technology and has efficiency more than cars running

on Petrol/Diesel/CNG while Hybrid Solar Vehicle has lower efficiency than vehicle running on Petrol/Diesel/CNG. So, this technology is for drivers who want to cover less distance. To overcome this constraint, “Plug-In Hybrid Electric Vehicle” came into existence.

“Toyota Prius Series” is an example of Hybrid Electric Vehicle technology, “Astrolab” is an example of Hybrid Solar Vehicle and “Chevrolet Volt” is an example of Plug-In Hybrid Electric Vehicle.

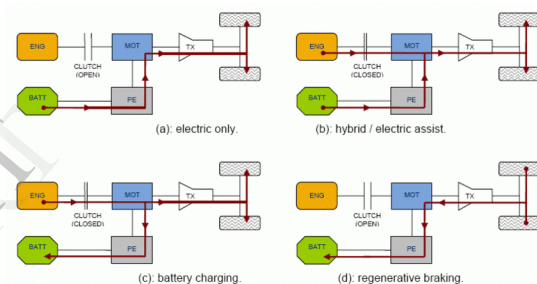

Fig. 1: Working Principle of Hybrid Vehicle

Regenerative braking is an energy recovery mechanism which slows down a vehicle by converting its kinetic energy into another form, normally into electrical energy, which can be used immediately or stored until needed in high voltage batteries. The electric motor is operated in reverse during braking or coasting, acting as generator. The rotors of electric traction motor are coupled with wheels, they experience opposing torque as current is induced in the motor coils. [12] The wheels transfer kinetic energy via drivetrain to generator. At the same time, generator resistance produced from the electricity created, slows the vehicle. When more braking torque is required than the generator alone can provide, additional braking is accomplished by friction brakes.

## II. TYPES OF HYBRID VEHICLE

### A. Hybrid Electric Vehicle (HEV)

A hybrid electric vehicle is a type of hybrid vehicle which combines a conventional internal combustion engine propulsion system with an electric propulsion system. Or in a technical way, a Hybrid Electric Vehicle is a type of technology which indulges both mechanical drive train and electric vehicle.

A mechanical drive consists of the Fuel tank (containing conventional fuels like petrol/diesel/CNG), the Combustion Engine, the gear box and transmission to the wheels in Fig. 2.

An electric drive consists of the Battery, an electric motor and Power Electronics for control as shown in Fig. 3.

The use of Ultracapacitors [1] has a high potential in the Hybrid Electric Vehicles. They have the advantage of being a more robust power device when compared to batteries (Lithium Ion and Nickel Metal Hydride), as an example during regenerative braking which is considered as a high powered event.

Classification of Hybrid Electric Vehicle: -

**Series Hybrid:** As shown in Fig. 4, [3] the traction power is delivered by the electric motor, while the internal combustion engine, via a generator, produces electric power to drive the electric motor [2]. The excess power is then stored in the battery pack. The Internal Combustion Engine is decoupled from the driven wheels and can be operated mostly in the maximum efficiency region. The major shortcomings of the series hybrid drive train configurations are the high power installed in each component and the request of a generator. In fact the energy from the Internal Combustion Engine is converted twice before to drive the wheels. Thus the system is more expensive than the parallel one.

**Parallel Hybrid:** As shown in Fig. 5, [3] there is direct mechanical connection between the hybrid power unit and the wheels. In addition, this layout has an electric traction motor that drives the wheels and can recuperate a share of the braking energy, in order to charge the batteries (regenerative braking) or help Internal Combustion Engine during acceleration conditions. In fact, Internal Combustion Engine and electric motor are coupled by a mechanical device. Then the electrical machine can be designed with a reduced capability, i.e. cost and volume. There are several configurations depending on the structure of the mechanical combination between the Internal Combustion Engine and the electrical motor. There can be a torque-coupling with a single shaft or two shaft configuration, a speed-coupling with planetary gear unit, a merge of both previous coupling.

**Series-Parallel Hybrid:** As shown in Fig. 6, [3] the series layout and the parallel layout are merged together in order to have both advantages. In particular the ICE is able to supply the electrical motor or charge the battery thanks to a generator.

**Complex Hybrid:** [3] There are two separate mechanical links obtaining a light transmission system and a flexible mounting. As an example, the front wheels are powered by hybrid propulsion, while the rear wheels have a pure electric system. There is a wi-deflexibility on the power flux managing.

Moreover, general Hybrid Electric Vehicle can be classified depending on the relevance of the power Table 1 [4, 5].

Table 1: Hybrid Electric Vehicle Classification based on power

	Micro	Mild	Full
Power (kW)	2.5	10-20	30-50
Voltage Level (V)	12	100-200	200-300
Energy Saving (%)	5-10	20-30	30-50
Price increase (%)	3	20-30	30-40

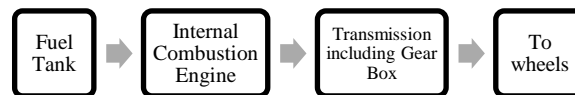

Fig. 2: Flow of energy within a mechanical drive train [10]

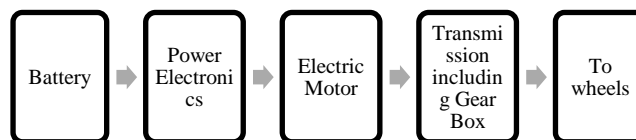

Fig. 3: Flow of energy within a electric drive train [10]

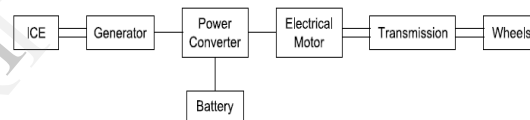

Fig. 4: Series Hybrid Structure

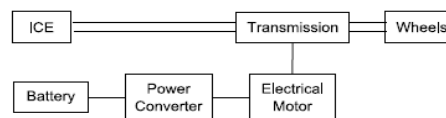

Fig. 5: Parallel Hybrid Structure

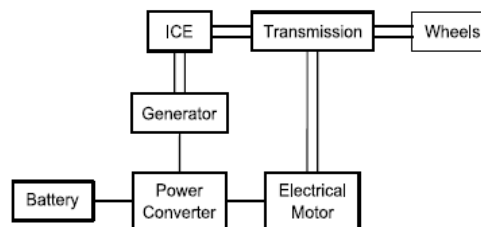

Fig. 6: Series-Parallel Hybrid Structure

B. Hybrid Solar Vehicle (HSV)

This technology is an integration of Vehicle and Photovoltaic Panels. Normally, photovoltaic panels are mounted on the roof-tops of the vehicles. It is also classified into four types: - Series Hybrid, Parallel Hybrid, Series-Parallel Hybrid and Complex Hybrid. Out of which, Series Hybrid technology is very efficient and more research is going on this type as shown in Fig. 7.

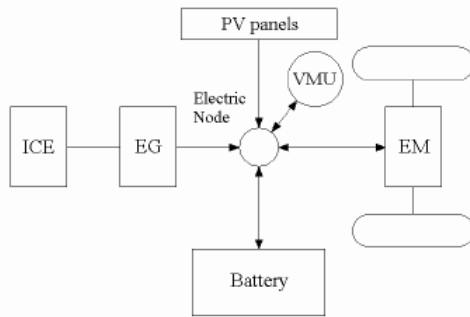

Fig. 7: Basic Diagram of series Hybrid Solar Vehicle [6]

### C. Plug-In Hybrid Electric Vehicle (PHEV)

A plug-in hybrid electric vehicle is similar to the hybrid electric vehicles (HEVs) on the market today, but it has a larger battery that is charged both by the vehicle's gasoline engine and from plugging into a standard 110 V/230V electrical outlet for a few hours each day [7].

Classifications of Plug-In Hybrid Electric Vehicle:-

**Series Plug-In Hybrids:** [8] Also called as Extended Range Electric Vehicles (EREVs). Only the electric motor turns the wheels; the gasoline engine is only used to generate electricity. Series plug-ins can run solely on electricity until the battery needs to be recharged. The gasoline engine then generates electricity to power the electric motor. For shorter trips, these vehicles might use no gasoline at all.

**Parallel or Blended Plug-In Hybrids:** [8] Both the engine and electric motor are mechanically connected to the wheels, and both propel the vehicle under most driving conditions. Electric-only operation usually occurs only at low speeds.

## III. CASE STUDY

### A. Toyota Prius Series

#### A.1. First Generation: THS (Toyota Hybrid System)

The first generation consisted of two hatchback models the "NHW10" and the "NHW11".

Challenges:-

- Longevity of the battery (7-10 years)
- Need for a hybrid system
- High performance of engine for charging the battery.

Solutions:-

- The battery pack is always charged between 40%-60% for maximum efficiency.
- The introduction to the "Toyota Hybrid System".
- Introduction of the Double Overhead Cam-Shaft (DOHC) engine.

Benefits: -

The introduction of the DOHC engine allowed the engine to have four valves per cylinder. By having four valves in the cylinder instead of two, a larger portion of the area could be used to let air in and exhaust out. The engine made more power if more air entered the cylinder, and it wasted less power and it was easier to pump the exhaust out of the cylinder. At higher engine speeds, the engine pumped a lot of air though the cylinders. Having four valves per cylinder allowed the engine to pump enough air to run and make useful power at these higher speeds. Hence the general problem of low speed was overcome.

#### A.1.1. Working of Toyota Hybrid System

The Toyota Hybrid system consists a petrol engine along with two motor generators ( $MG_1$  and  $MG_2$ ) a power control unit and a battery.

When the car is started it runs solely on the electric motor ( $MG_2$ ). Later when the car achieves a higher speed the petrol engine kicks in and the car runs both on the motor and the petrol engine. Moreover the engine also operates a generator with the help of a power split device which in turn drives the electric motor ( $MG_2$  (288 V)). This power splitting is controlled by the power control unit which manages the power for the maximum efficiency.

During braking the motor acts as a generator and the energy recovered is stored in the battery. The battery doesn't need any external charging. If the battery is drained, the car is run on the petrol engine in "stand mode" which charges the battery.

Drawbacks:-

- The backing of the car at steep was difficult.
- The ride was jerky at times

Overall, the mileage for the First Generation Prius was 5.6 L/100 km in city driving, 5.7 L/100 km for highway driving and 5.7 L/100 km for combined driving.

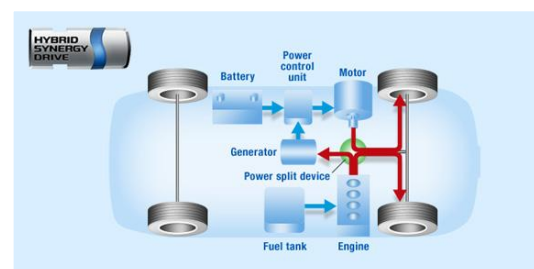

Fig. 8: Diagram of Toyota Hybrid System

#### A.2 Second Generation: Hybrid Synergy Drive

The Hybrid Synergy Drive adds a DC to DC converter boosting the potential of the battery to 500 V or more. This allows smaller battery packs to be used, and more powerful motors.

The second generation Prius also have an all electric Air conditioner. This removes the need to continuously run the engine when cabin cooling is required. In addition, the Motor (MG<sub>2</sub>) is linked to the front wheel transaxle by means of a second planetary gear set, thereby making it possible to increase the power density of the motor. Moreover the power control unit (PCU) uses indirect cooling.

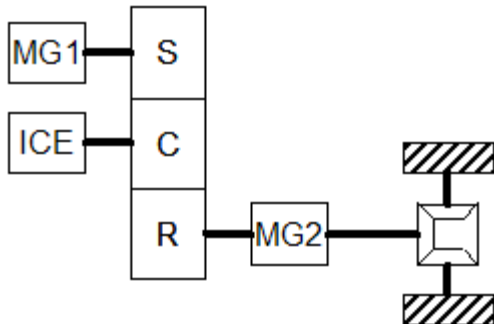

Fig. 9: Hybrid Synergy Drive mechanism

The original Prius used shrink-wrapped 1.2 volt D cells. The Toyota Hybrid System relies on the voltage of the battery pack — between 276 and 288 V. The Prius II with HSD has the following improvements compared to the Prius I:

- Superior power: ICE + 8% and electrical MGs +50% (up to 500 V)
- Torque electrical motor + 14 %
- Inferior electrical losses
- Improved charge capacity of the generator
- New HV battery with superior power density and charge/discharge capacity, and 14% weight reduction.

However both these generations use the 1.5 litre 14 DOHC engines. Overall, the mileage for the Second Generation Prius was 4.9 L/100 km in city driving, 5.2 L/100 km for highway driving and 5.1 L/100 km for combined driving.

### A.3 Third Generation: Hybrid Synergy Drive

The new Prius III (2009) has a re-engineered Hybrid Synergy Drive system. It brings significant reductions in weight and size, contributing to the overall improvements in fuel economy:

- The internal combustion engine is a new 1.8-litre VVT-i Atkinson cycle petrol engine with cooled Exhaust Gas Recirculation. It is more powerful (90 hp vs 70 hp).
- The electric motor MG2 is 20% more powerful (60kW vs 50 kW) and 33% smaller.
- The Ni-MH battery power has been increased to a maximum 27kW (+2kW), and has reduced size.
- The new inverter(PCU) is 36% lighter, faster switching for improved efficiency and now converts the battery's DC into a higher, 650V (+150V) voltage to drive the electric motor. It also involves direct cooling hence making it 37% compact and much faster.
- Fuel economy is improved by 14% (4 litre /100 km); CO<sub>2</sub> emissions are reduced to 89g/km.

- The third generation Prius also has a gear set called the 'motor speed gear reduction' (which is a planetary gear set) for the MG<sub>1</sub>.

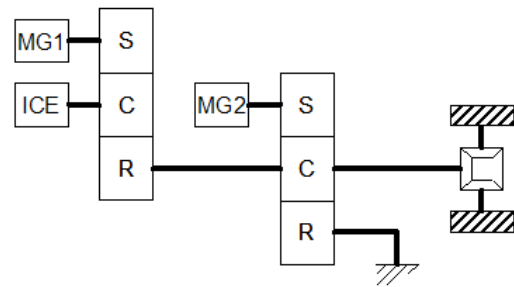

Fig. 10: Hybrid Synergy Drive mechanism

Overall, the mileage for the Second Generation Prius was 3.70 L/100 km in city driving, 3.90 L/100 km for highway driving and 3.90 L/100 km for combined driving.

### A.4. Toyota Prius Solar

A prototype of Solar Prius has also been recently developed by Solar Electric Vehicles, equipped with a PV panel of 16% nominal efficiency. It has been estimated that the PV Prius can have a range based on solar power alone between 5 and 8 miles per day, and that it can consume between 17% and 29% less gasoline than the standard Prius.

With the Solar Electric Vehicle (SEV) solar system, the Toyota Prius can operate up to 30 miles per day in electric mode thus improving fuel economy by up to 34-60% (depending on driving habits and conditions).

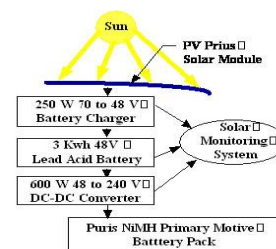

Fig. 11: Connection Diagram for Solar Components of the Photovoltaic (PV) Prius.

### A.5. Toyota Prius Plug-In Hybrid

This version of Prius came out in 2012 which involves a 4.4 kWh Lithium ion battery which allows an all electric range of 23 km. The lithium-ion battery pack can be charged in 180 minutes at 120 volts or in 90 minutes at 240 volts. According to Toyota the Prius plug-in is expected to release only 49g CO<sub>2</sub> -emissions. Its mileage is same as the third generation Prius except for the fact that it has an all electric efficiency of 2.5L/100km. The main advantage is that the battery can be charged at any outlet.



### B.1. Astrolab - Venturi Automobiles

Capable of running on very little energy (16kW motor) and of recharging with solar energy even when in motion, this vehicle of another era does not, however, need to be permanently exposed to the Sun in order to move. It's NiMH Venturi NIV-7 batteries liquid cooled in fact enable it to reconstitute stored energy, whether solar or from the electricity supply, making it the world's first electro-solar hybrid vehicle. With a top speed of 120 km/hr. and a range of 110 kilometres, allow it for extensive trips on an everyday basis. This is the first vehicle to consume no fossil resources, with CO<sub>2</sub> emissions that are necessary to its construction even set off by environmentally friendly actions. The Astrolab has opened up a new era for automobile architecture: light and high profiled, it offers the rays of the Sun for 3.6 m<sup>2</sup> of the photovoltaic cells (for an overall vehicle length of fewer than 4 metres).



Fig. 12: Picture of Astrolab car- Venturi Automobiles [9]

#### IV. Advantages and Disadvantages

The reason for two motors is in the strengths and weaknesses of both types. [11] Specifically, electric motors use no energy during idle - they turn off - and use less than gas motors at low speeds. Gas motors do better at high speeds and can deliver more power for a given motor weight. That means during rush hour stop and go driving, the electric motor works great and, as an added benefit, does not produce any exhaust thus reducing smog levels. At higher speeds - above 40 km/hr - the gas motor kicks in and gives that peppy feel so many car owners look for when driving on the highway. Another benefit of having the gas motor is it charges the batteries while it's running. Many an electric car owner has been stranded just out extension cord range of an outlet. Hybrid owners can forget about this annoyance; the gas motors starts automatically when the battery gets low and proceeds to charge the battery - a hybrid never needs to be plugged into an outlet. Of course, if you forget to fill the tank. Still, you can carry a gas can a half mile while a tow truck is necessary in a straight electric car. Honda Insight, All this new technology comes at a price: a hybrid car is complex and expensive. It has two motors and all the ancillary systems to manage them plus a heavy battery and a regeneration system used to produce electricity during breaking. All of these systems must work together, adding complexity. While cars and, just as importantly, the computers that control them, have become more reliable, they still suffer from failures. So owners of hybrids can expect more time in the shop and larger repair

bills. Hybrids are the most gasoline efficient of all cars - they typically get 20.4 to 25.51 kmpl (claimed).

Not bad, but only about 20% to 35% better than a fuel efficient gasoline powered vehicle - like the Honda Civic, for example, that gets 15.3 kmpl. But, when comparing prices - hybrids cost from \$19,000 to \$25,000 and gas saver cars cost \$14,000 to \$17,000 - the justification to buy becomes less clear. Indeed, the difference in average annual fuel bills - \$405 for a Honda Insight versus \$635 for a Honda Civic - means you may never recoup the added initial cost of a hybrid.

Over a ten year period owning a hybrid will save you only \$2,300 - less than the cost difference for comparably equipped cars. Much of the fuel efficiency comes from improvements in aero dynamics, weight reduction and, the biggest change: a smaller, less powerful gas engine. In fact, any car will get substantially better mileage just by reducing the engine size. The main reason this is not done has to do customer demand - they want the extra power and zippiness.

Divers find that real mileage from hybrids is actually about 10% less than claimed. When consulting manufactures web pages for mileage tips, they list the same ones that would give better fuel economy from any car: drive slow, no jack rabbit starts, etc. But hybrid cars offer more than just great fuel economy, they offer many green advantages as well. Even a small increase in fuel economy makes a large difference in emissions over the life of the car. Also, in large cities where pollution is at its worst, they make an even larger difference since they produce very little emissions during low speed city driving and the inevitable traffic jams.

While the US has just started producing hybrids, the Japanese are the recognized leaders. Honda and Toyota are the two largest producers with the Insight and Prius. US car makers are well behind. In fact, during recent introduction of a new hybrid by GM - the Mercury Mariner, they admitted they had to license over 20 separate technologies from the Japanese. US car makers still specialize in SUVs and trucks - Ford has even introduced a hybrid version of its popular Escape SUV. Industry analysts say US hybrids are just token models - not a serious attempt to get into the market.

The reason for hybrid introduction has to do with Corporate Average Fuel Economy (CAFE) regulations. Current standards mandate that average mileage of the fleet of cars sold by an automaker should be 11.69 kmpl. This means that if an automaker sells one hybrid car that gets 25.51 kmpl, it can then sell four less efficient cars - like SUVs and trucks - that only get 8.5 kmpl.

#### V. CONCLUSION

Hybrid Cars use no energy during idling state; they turn off and use less energy than petrol engines at low speeds. At lower speeds, no smog is emitted maintaining its sustainable advantage. Till lower speed, the car runs on the electric motor and on cruising speed, it runs on IC engine. They offer greater mileage than conventional cars. Noise pollution and emission of CO<sub>2</sub> is considerably reduced. But, they are more expensive than conventional cars, are more complex in construction and

working than IC engine cars, offer larger repair bills, capacity of batteries is not much advanced.

Table 2: Specifications of various Hybrid Vehicles

Sr. No	Car Technology	Fuel	Electric	Transmission	Length x Width x Height (m <sup>3</sup> )	Range
1	Toyota Prius (XW10): 1 <sup>st</sup> Generation [13]					
1 (a)	NHW10 (1997-2001)	1.5 L Gasoline DOHC I4; CR-13.5:1; Torque: 102 Nm @ 4000 rpm; 58 hp, 43 kW @ 4000 rpm	288 V Electric Motor; 40 hp; 30 kW @ 940 rpm Torque: 305 Nm @ 0 rpm	1 - speed planetary gear	4.275 x 1.695 x 1.491	EPA Rated: 20.4 kmpl
1 (b)	NHW11 (2001-2003)	1.5 L Gasoline DOHC I4 VVT-I; CR- 13:1; Torque: 110 Nm @ 4200 rpm; 70 hp; 52 kW @ 4500 rpm	273.6 V Electric Motor; 44 hp; 33 kW @ 1040 rpm Torque: 350 Nm @ 0 rpm		4.308 x 1.695 x 1.463	EPA Rated: 17.64 kmpl
2	Toyota Prius (XW20): 2 <sup>nd</sup> Generation (2004-2009) [14]	1.5 L Gasoline DOHC I4 VVT-I; Torque: 115 Nm @ 4200 rpm 76 hp; 57 kW @ 5000 rpm	500 V Electric Motor; 67 hp; 50 kW @ 1200 rpm Torque: 400 Nm @ 0 rpm	1 - speed planetary gear	4.450 x 1.725 x 1.490	EPA Rated: 19.77 kmpl
3	Toyota Prius (XW30): 3 <sup>rd</sup> Generation (2009-present) [15], [16]	1.8 L Gasoline I4 VVT-I; Torque: 142 Nm @ 4000 rpm 98 hp; 73 kW @ 5200 rpm	650 V Electric Motor; 60 kW Torque: 207 Nm @ 0 rpm	CVT	4.460 x 1.745 x 1.490	EPA Rated: 21.04 kmpl
4	Toyota Prius c (2011-present) [17]	1.5L Gasoline DOHC 16-valve I4 VVT-I; CR- 13.4:1; Torque: 111 Nm @ 4000 rpm 73 hp; 54 kW @ 4800 rpm	520V Electric Motor; 60 hp; 45 kW Torque: 169 Nm	E-CVT	4.000 x 1.690 x 1.450	EPA Rated: 21.04 kmpl
5	Toyota Prius Plug-In Hybrid (2012-present) [18], [19]	1.8 L Gasoline 4-cylinder DOHC I4 VVT-I; CR- 13:1; 98 hp 73 kW @ 5200 rpm; Torque: 142 Nm @ 4000 rpm	650 V Electric Motor; 80 hp; 60 kW Torque: 207 Nm	1-speed planetary gear	4.460 x 1.745 x 1.490	EPA rated: 40.38 kmpl Hybrid mode: 21.26 kmpl
6	Chevrolet Volt (2011-present) [20]	1.4 L Gasoline DOHC I4; CR-10.5:1; 84 hp; 63 kW @ 4800 rpm; Torque: NA	Two Electric Motors - 111 kW (drive motor) ; 54 kW (generator motor); 149 hp; Torque: 368 Nm	CVT	4.498 x 1.788 x 1.438	Extended Range: 563.27 km
7	Astrolab - Venturi Automobiles [21]	Not Applicable	A synchronous motor: 16 kW Torque: 50 Nm Solar Power: 600W	NA	3.800 x 1.840 x 1.200	On Battery: 110 km
8	Eclectic - Venturi Automobiles [22], [23]	Not Applicable	Electro Motor: 16 kW/21 Bhp Torque: 50 Nm Solar roof: 8 m <sup>2</sup> Solar Power: 72 W Wind Power: 300W	NA	2.860 x 1.850 x 1.750	On Battery: 50 km
9	Honda Insight (ZE2) (2010-2014) [24]	1.3 L LDA series I4 8 valve SOHC i-VTEC ; 98 hp; 73 kW @ 5800 rpm; Torque: 167 Nm @ 1000-1700 rpm	DC Brushless Motor; 144 V; 13 hp; 9.7 kW @ 1500 rpm; Torque: 79 Nm @ 1000 rpm	CVT	4.376 x 1.695 x 1.425	EPA rated: 17.54 kmpl
10	Honda Jazz Hybrid [25]	1.3 L i-VTEC+IMA; CR- 10.8:1; 65 kW ; Torque: 121 Nm	10 kW motor; Torque: 78 Nm	CVT	3.900 x 1.695 x 1.525	21.24 kmpl [28]
11	Honda CR-Z (ZF-1) (2010-present) [26]	1.5 L Gasoline SOHC 16-valve i-VTEC; 111 hp; 83 kW @ 6000 rpm; Torque: 144 Nm @ 4800 rpm	DC Brushless Motor; 14 hp; 10 kW @ 1500 rpm Torque: 79 Nm @ 1000 rpm	CVT	4.080 x 1.740 x 1.395	EPA rated: 15.73 kmpl
12	Honda Civic Hybrid: 3 <sup>rd</sup> Generation (2011-present) [27]	1.4 L Gasoline SOHC i-VTEC+IMA I4; CR- 10.8:1; 110 hp @ 5500 rpm; Torque: 172.19 Nm @ 1000-3500 rpm	DC brushless PM motor 108-172 V; 23 hp; 17 kW @ 1546-3000 rpm; Torque: 105.75 Nm @ 500-1546 rpm	CVT	4.525 x 1.755 x 1.430	EPA rated: 18.7 kmpl

## VI. REFERENCES

- [1] M. I. Marei, S. J. Samborsky, S. B. Lambert, M. M. A Salama. On the Characterization of Ultracapacitor Banks Used for HEVs, Proceedings of the IEEE Vehicle Power and Propulsion Conference, VPPC '06, Windsor, UK, 2006, pp. 1-6.
- [2] M. Ehsani, Y. Gao, S. Gay, A. Emadi. Modern Electric, Hybrid Electric, and Fuel Cell Vehilces, CRC Press: USA, 2005.
- [3] M. Barcaro, N. Bianchi, F. Magnussen. PM Motors for Hybrid Electric Vehicles. The Open Fuels & Energy Science Journal, Vol. 2, pp. 135-141, June 2009.
- [4] C.C. Chan. In Global Sustainable Mobility and EV/HEV/FCEV Development in China & Japan, Keynote Presentation of the IEEE Vehicle Power and Propulsion Conference, VPPC'06, Windsor, UK, 2006.
- [5] T. Yaegashi. In Challenge of Achieving Sustainable Mobility through Hybridization, Research and Development of Hybrid Vehicles in Japan and Sweden Seminarim, Göteborg, Sweden, 2006.
- [6] Zs. Preitl, P. Bauer, J. Bokor. Fuel Consumption optimization for Hybrid Solar Vehicle, Page: 11-18. International Workshop on Hybrid and Solar Vehicles. University of Salerno, Italy. November 5-6, 2006. <www.dimec.unisa.it/WHSV>, 4<sup>th</sup> February 2013.
- [7] "What is Plug-In Hybrid?" <www.transportation.anl.gov/phev>. 22<sup>nd</sup> December 2014.
- [8] "Different Kinds of Plug-in Hybrids" <www.fueleconomy.gov/feg/phevtech.shtml> 22<sup>nd</sup> December 2014.
- [9] Astrolab - Venturi Automobiles, <en.venturi.fr/vehicules/venturi-range/astrolab/overview>, 22<sup>nd</sup> December 2014.
- [10] Hybrid Electric Vehicles: An Overview of current technology and its application in developing and transitional countries. Printed, United Nations Environment Programme, Nairobi, Kenya, September 2009.
- [11] "Hybrid Cars -- Pros and Cons", <www.phys.org/news10031.html>, 22<sup>nd</sup> December 2014.
- [12] "Regenerative braking systems", <http://www.bosch-mobility-solutions.com/media/ubk\_europe/db\_application/downloads/pdf/safety\_1/en\_4/CC\_Regenerative\_Braking\_Systems.pdf>. 22<sup>nd</sup> December 2014
- [13] "Toyota Prius (XW10)", <http://en.wikipedia.org/wiki/Toyota\_Prius\_(XW10)>, 22<sup>nd</sup> December 2014.
- [14] "Toyota Prius (XW20)", <http://en.wikipedia.org/wiki/Toyota\_Prius\_(XW20)>, 22<sup>nd</sup> December 2014.
- [15] "Toyota Prius (XW30)", <http://en.wikipedia.org/wiki/Toyota\_Prius\_(XW30)>, 22<sup>nd</sup> December 2014.
- [16] "Review: Toyota XW30 Prius, Specifications", <http://australiancar.reviews/reviews.php#!content=review&make=Toyota&model=Prius&gen=913>, 22<sup>nd</sup> December 2014
- [17] "Toyota Prius c, Specifications", <http://www.toyota.com/content/ebrochure/2014/priusc\_ebrochure.pdf>, 22<sup>nd</sup> December 2014.
- [18] "Toyota Prius Plug-In Hybrid", <http://en.wikipedia.org/wiki/Toyota\_Prius\_Plug-in\_Hybrid>, 22<sup>nd</sup> December 2014.
- [19] "Toyota Prius Plug-In Hybrid, Specifications", <http://www.toyota.com/content/ebrochure/2014/priusc\_ebrochure.pdf>, 23<sup>rd</sup> December 2014.
- [20] "Chevrolet Volt Specifications", <http://gm-volt.com/full-specifications/>, 23<sup>rd</sup> December 2014.
- [21] "Venturi Astrolab - First Commercially Available Solar Car", <http://puregreencars.com/Green-Cars-News/Concepts/Venturi-Astrolab-First-Commercially-Available-Solar-Car.html>, 23<sup>rd</sup> December 2014.
- [22] <http://www.ultimatecarpage.com/spec/2907/Venturi-Eclectic-Concept.html>, 23<sup>rd</sup> December 2014.
- [23] "Venturi Eclectic Production Model", <http://www.futurecars.com/futurecarscom/future-cars/future-car-of-the-week/venturi-eclectic-production-model-not-so-much>, 23<sup>rd</sup> December 2014.
- [24] "Honda Insight: 2<sup>nd</sup> Generation", <http://en.wikipedia.org/wiki/Honda\_Insight#Second\_generation\_.282009.E2.80.93.29>, 23<sup>rd</sup> December 2014.
- [25] "Honda CR-Z Hybrid (ZF-1)", <http://en.wikipedia.org/wiki/Honda\_CR-Z>, 23<sup>rd</sup> December 2014.
- [26] "Honda CR-Z", <http://en.wikipedia.org/wiki/Honda\_CR-Z>, 23<sup>rd</sup> December 2014.
- [27] "Honda Civic Hybrid: 3<sup>rd</sup> Generation", <http://automobiles.honda.com/civic-hybrid/specifications.aspx>, 23<sup>rd</sup> December 2014.
- [28] "Honda Jazz Hybrid: Fuel Economy", <http://www.telegraph.co.uk/cars/honda/jazz>, 23<sup>rd</sup> December 2014.