

# Study and Development of a New Mechanism in an Endoscopic Surgical Instrument

Zheng (Jeremy) Li

University of Bridgeport/Department of ME, Bridgeport, CT 06604, USA

[zhengli@bridgeport.edu](mailto:zhengli@bridgeport.edu)

## ABSTRACT

**This article provides a new surgical instrument with improved and enhanced mechanism to reliably apply the multiple titanium clips to patients' tissue or vessel during surgical procedure. Compared with the existing surgical clip instrument, an improved clip delivery system has been designed and developed in this new instrument to resolve the common problems of clip accidental shooting out while the surgical clip is being loaded into jaws from clip channel. This can prevent patient's organs and tissues from being damaging due to clip's accidental shooting out in the surgical process. This improved instrument is analyzed and optimized by computer aided modeling and simulation to prove its feasible performance with good mechanical advantages.**

## II. KEYWORDS

Ligation of blood vessels and tissues, Computational modeling, Mechanical advantage, System optimization, Finite element analysis,

## III. NOMENCLATURE

$F_{load}$  -- load on instrument tip  
 $F_{pivot}$  -- load on trigger handle pivot  
 $F_{finger}$  -- load on surgeon's finger  
 $V_{linear}$  -- linear moving velocity of drive bar  
 $V_{angular}$  -- angular velocity at trigger handle pivot point  
 $\omega$  -- angular speed of trigger handle at pivot point  
 $T$  -- torque on trigger handle pivot point  
 $R$  -- distance between handle pivot point and surgeon's finger position  
 $(VR)$  -- velocity ratio

## IV. INTRODUCTION

The ligation of blood vessels, severed tissues and/or other organs to stop bleeding are required during surgical procedures [1], [2]. Surgical clip applicators to quickly apply the surgical clip onto organ, vessel or tissue are known for years [3]. These surgical clip applicators include the applications of single and multiple clip procedures. In single clip surgical procedure, a new clip will be added to the instrument after applying each clip [4], [5]. In multiple clip surgical procedure, multiple can be sequentially applied to vessel and organ. The surgical clip instruments usually have a trigger/handle mechanism, a major unit body, a clip crimping system and several other functioning parts including a pair of jaws. This improved surgical clip instrument is proposed for the open/endoscopic surgical applications. Although currently a few of surgical clip instruments for continuous clip advance have been proposed, a further improvement for proper clip delivery instrument with less complicated mechanism and high reliability is required to have the effective occlusion of a blood vessel.

## V. ANALYSIS OF INSTRUMENT

Referring Figs. 1 – 3, the apparatus is first placed onto patient's body tissue or vessel and then clip is delivered to the jaws and secured onto the tissue or vessel when surgeons close the trigger handles. When surgeons release the trigger handles, jaws are open and driving pusher bar and trigger handles return to their original positions for instrument next firing cycle. Compared with the current clip delivery apparatus in which the clip is delivered to jaws by

compression spring that sometime causes the clip's accidentally shooting from instrument, the clip delivered into jaws is well guided and controlled in this new design. The driving pusher bar connected to the pivot pin on the trigger handles moves distally to deliver clip into jaw when surgeons start to close the instrument handles. Such clip's linear motion can be well controlled by surgeons to prevent the clip from accidentally shooting in instrument. Another current issue arises in the field is that the jaws can be twist when extra external load exerted while surgeon applies the instrument onto the thick tissue or vessel, bone frame and other strong organ areas. An enhanced structure is configured in this new design to prevent the jaws from twist. Also a movable wedge plate in this new design is inserted between the pair of jaws when trigger handles are released to prevent the instrument from being manipulated while not in operation. The prototype of this new design has been proved that this new surgical auto-suture apparatus functions properly.

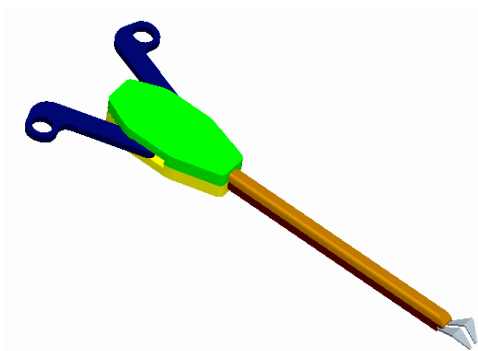

Figure 1. Biomedical instrument



Figure 2. Instrument front view

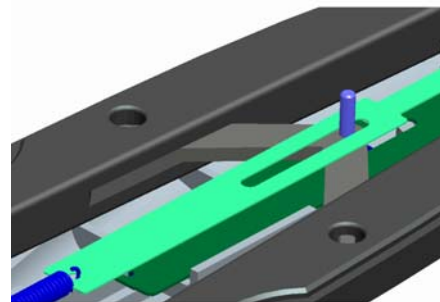

Figure 3. Mechanism of instrument

### VI. COMPUTATIONAL MODELING

The energy balance equation of this instrument driving mechanism can be shown as follows:

$$F_{load} * V_{linear} = T * \omega \tag{1}$$

Since the torque  $T = F_{pivot} * R$ , then

$$T * \omega = F_{pivot} * R * \omega = F_{pivot} * V_{angular} \tag{2}$$

$$\text{So, } F_{load} * V_{linear} = F_{pivot} * V_{angular} \tag{3}$$

$$F_{load} = (V_{angular} / V_{linear}) * F_{pivot} = (VR) * F_{pivot} \tag{4}$$

(VR) – velocity ratio

From the geometry of this instrument trigger handle setup:

$$F_{finger} * 4.85 = F_{pivot} * 2.25 \tag{5}$$

$$F_{pivot} = 2.155 * F_{finger}$$

$$\text{Then, } F_{load} = (VR) * F_{pivot} = (VR) * 2.155 * F_{finger} \tag{6}$$

The simulation result from computer modeling on instrument driving mechanism is predicted in Fig. 4 and the mechanical advantage at full trigger/handle close of the surgical clip is:

$$\text{Mechanical advantage} = (VR) * 2.067 = (.04877 / .03545) * 2.067 = 2.965 \tag{7}$$

The above result represents that if 20 lb force is needed to fully form or close the surgical clip, the force loaded on surgeon's finger will be 3.37 lbs which are lower than the normal spec of 4 lbs in surgical operation procedure and meet the surgeons' satisfaction and requirement.

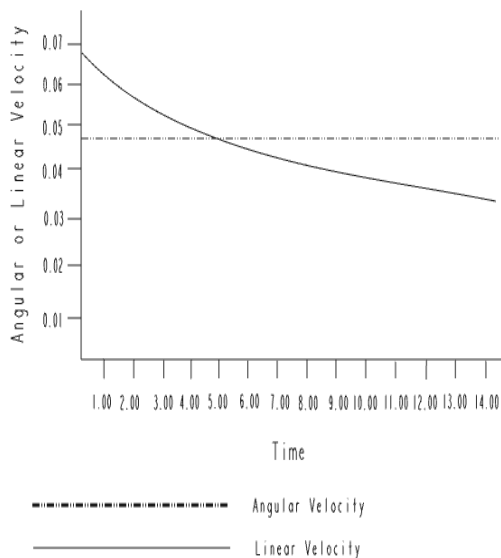

Figure 4. Diagram of mechanical advantage

### VII. CONCLUSION

The feasible functioning of this new biomedical auto-suture apparatus has been proved based on the instrumental functional study, computerized simulation and prototype testing. The major advantages of this instrument include that the clip

delivery is well guided and controlled, mechanism is simple and compact. The prototype of this biomedical auto-suture apparatus has been sent to the hospitals for surgeons' further evaluations and the preliminary clinician's evaluation indicated the feasibility of this instrument with its potential features.

### REFERENCES

- [1]. Lin HJ, Lo WC, Cheng YC, Peng, CL, "Endoscopic Hemoclip Versus Triclip Placement in Patients with High Risk Peptic Ulcer Bleeding", *Journal of Gastroenterol*, 2007, Volume 102, pp 539-543.
- [2]. Cheng AW, Chiu PW, Chan PC, Lam SH, "Endoscopic Hemostasis for Bleeding Gastric Stromal Tumors by Application of Hemoclip", *Journal of Laparoendoscopic & Advanced Surgical techniques*, 2004, Volume 14, pp 169-171.
- [3]. Piatt, J., Starly, B., Faerber, E. and Sun, W., "Application of Computer-Aided Design Methods in Craniofacial Reconstructive Surgery Using a Commercial Image-Guidance System", *Journal of Neurosurgery*, 2006, Vol. 104(1 Suppl), pp. 64-67.
- [4]. Evans, P., Starly, B. and Sun, W., "Computer-Aided Tissue Engineering for Design and Evaluation of Lumbar-Spine Arthroplasty", *Journal of Computer-Aided Design and Application*, 2006, Vol. 3(6), pp. 771-778.
- [5]. Sun, W., Starly, B., Nam, J. and Darling, A., "Bio-CAD Modeling and Its Application in Computer-Aided Tissue Engineering", *Computer-Aided Design*, 2005, Vol. 37(11), pp. 1097-1114.