

Biosensor for the Determination of Biochemical Oxygen Demand in Rivers

Gab-Joo Chee

*Department of Biochemical Engineering, Dongyang Mirae University
South Korea*

1. Introduction

Population growth and industrialization have caused serious environmental pollution. Environmental pollution has become global issues beyond a region or a country, and is the introduction of contaminants, which are synthetic chemicals, pesticides, and heavy metals etc, into environmental system. Biopersistent organic chemicals of them particularly cause instability, disorder, harm or discomfort to ecosystem. Biopersistent organic chemicals are present as pollutants in wastewater effluents from industrial manufacturers or normal households. Environmental problems with such organic pollutants are becoming progressively worse all over the world. They are increasingly found in groundwater wells, rivers, lakes, and seas. Our drinking water sources, in particular, have also become polluted. A rapid and online monitoring of organic pollutants in water systems is a process that is essential for not only health of human but also environmental protection and ecosystem. Environmental pollutants in water systems have been evaluated as indicators including biochemical oxygen demand (BOD), chemical oxygen demand (COD), and total organic carbon (TOC) etc. Unlike chemical analyses such as COD and TOC, BOD is a method evaluated by the microbial ecosystem by the American Public Health Association (APHA) (APHA, 1986) because the indicator is based on the metabolic activity of aerobic microorganisms. Therefore, BOD analysis directly represents some influences of organic pollutants on natural ecosystems. In 1884, the modern concept of biochemical oxidation aroses, when it was showed that the decrease in the dissolved oxygen (DO) content of incubated samples was caused by metabolic activity of the microorganisms present (Leblanc, 1974).

The 5-day BOD (BOD_5) test method, however, requires an incubation period of 5 days under specified standard conditions described by the American Public Health Association Standard Methods Committee. This method is not desirable not only for process control and environmental monitoring, but also for remediation it produces a quick feedback. Thus, a fast and simple estimation of BOD is required as an alternative method to circumvent the disadvantages of the conventional test (BOD_5). A rapid and reliable method for BOD estimation was first developed by Karube et al. (Karube et al., 1977b). Since then many kinds of microbial sensors instead of BOD_5 analysis have been reported (Kulys & Kadziauskiene, 1980; Lin et al., 2006; Riedel et al., 1990; Sakaguchi et al., 2003; Stand & Carlson, 1984; Tanaka et al., 1994; Yang et al., 1997; Yoshida et al., 2000). They generally consist of microorganisms

immobilized on a porous membrane and an oxygen probe. In addition, bioelements have been used for over 17 species of microorganisms, and transducers have adopted either amperometric or optical oxygen probes. These microbial sensors have been developed for BOD analysis in industrial effluents, which contain high concentrations of organic pollutants. Solutions containing glucose and glutamic acid (GGA), which are adopted to the BOD₅ test method by the APHA, have been used as standard for the calibration of BOD sensors.

On the other hand, rivers, which are drinking water sources, generally contain biopersistent organic compounds such as humic acid, lignin, tannic acid, and gum arabic. In river waters in Japan, the BOD values are generally <10 ppm, and especially drinking water sources < 3 ppm (River Bureau, 1992). The microbial biosensors described above are not suitable to evaluate low BOD in drinking water sources. Therefore, the biosensor for the evaluation of low BOD in rivers has been developed and applied.

2. Constituents of BOD sensor systems

BOD sensor systems consist of a bioelement and a transducer. Bioelements utilized in BOD sensors have shown high respiration rate to organic compounds in industrial effluents and wastewaters. Bioelements are as follows: *Arxula adeninivorans* LS3 (Chan et al., 1999; Lehmann et al., 1999), *Bacillus subtilis* (Riedel et al., 1988), *Bacillus subtilis* and *Bacillus licheniformis* (Tan et al., 1992), *Citrobacter* sp. and *Enterobacter* sp. (Galindo et al., 1992), *Enterobacter cloacae* (Villalobos et al., 2010), *Clostridium butyricum* (Karube et al., 1977a), *Hansenula anomala* (Kulyš & Kadziauskiene, 1980), *Klebsiella oxytoca* (Ohki et al., 1994), *Lipomyces kononenkoae* (Reiss et al., 1993), *Photobacterium phosphoreum* (Hyun et al., 1993), *Pseudomonas putida* (Li & Chu, 1991), *Rhodococcus erythropolis* and *Issatchenkia orientalis* (Riedel, 1998), *Saccharomyces cerevisiae* (Seo et al., 2009), *Serratia marcescens* LSY4 (Kim & Kwon, 1999), *Torulopsis candida* (Sangeetha et al., 1996), *Trichosporon cutaneum* (Hikuma et al., 1979; Karube et al., 1977b; Yang et al., 1996), activated sludge (Sakai et al., 1995), mixture of microorganisms (Stand & Carlson, 1984), multi-species culture (BODSEED) (Tan & Wu, 1999), and thermophilic bacteria (Karube et al., 1989). Transducers are typically two oxygen probes, which are a Clark oxygen electrode described as an electrical current and an oxygen optrode displayed as fluorescence intensity. A Clark oxygen electrode (Karube et al., 1977b; Riedel et al., 1988; Seo et al., 2009; Tan & Wu, 1999; Yang et al., 1996) has been widely adopted in BOD sensors, but recently an oxygen optrode (Chee et al., 2000; Jiang et al., 2006; Kwok et al., 2005; Lin et al., 2006) is also often applied. An oxygen electrode consists of a platinum cathode, a plumbum anode, a PTFE membrane and an electrolyte solution. While an oxygen optrode contains a fluorescer and an optical fiber. The presence of oxygen, acting as a quencher, reduces fluorescence intensity of the indicators.

2.1 Media and bioelement

The composition of the medium was selected according to the analysis of the secondary effluents from the municipal sewage treatment plants in Japan (Murakami et al., 1978; Tanaka et al., 1994). The limited medium involved humic acid, lignin, tannic acid, gum arabic, and surfactant as carbon sources. These organic compounds could not be easily biodegradable by microorganisms. For the isolation of microorganisms utilizing refractory organic compounds, the medium had the following composition per liter of distilled water:

nitrohumic acid, 2 g; gum arabic, 2 g; sodium ligninsulfonate (NaLS), 2 g; tannic acid, 2 g; linear alkylbenzene sulfonate (LAS), 2 g; NaNO₃, 2.2 g; NaH₂PO₄, 0.2 g; Na₂HPO₄, 0.3 g; MgSO₄, 0.2 g; KCl, 0.04 g; CaCl₂, 0.02 g; yeast extract, 0.02 g; FeSO₄·7H₂O, 1 mg; MoO₃, 10 µg; CuSO₄·5H₂O, 5 µg; H₃BO₃, 10 µg; MnSO₄·5H₂O, 10 µg; ZnSO₄·7H₂O, 7 µg; the final pH being 7.0. For the solid medium, 1.0% agarose was added. A serum bottle containing 20 mL of the medium was cultured at 30°C with shaking at 170 rpm. Subculturing was carried out every five days, each transfer involving the addition of 1 mL of broth to 20 mL fresh medium.

Many soils, muds and activated sludge samples were collected and screened as to their ability to biodegrade humic acid and lignin etc. *Pseudomonas putida* strain SG10 as an optimal bioelement was isolated under aerobic conditions in the limited medium (Chee et al., 1999b).

2.2 Measuring principles

2.2.1 The BOD₅ test method

The 5-day BOD (BOD₅) test method has been adopted in 1936 by the American Public Health Association Standard Methods Committee (APHA, 1986). The BOD₅ test method, however, requires not only many complicated procedures, including a 5-day incubation, but also experience and skill to get reproducible results. BOD₅ is defined as the biochemical oxygen demand of wastewaters, effluents, and polluted waters measured over 5 days at 20°C. Dissolved oxygen (DO) is measured initially and after incubation, and the BOD is computed from the difference between initial and final DO. The parameter is widely used for the determination of biodegradable organic pollutants in water systems.

2.2.2 Biosensor method

BOD sensors consist of a biofilm and an oxygen electrode. A biofilm is a suitable microorganism immobilized on a porous cellulose membrane. Generally, the BOD levels by a biosensor are estimated with the steady-state method. A BOD sensor is immersed into a buffer solution saturated with an air, and in a few minutes the current output of an oxygen probe becomes a steady state, because the diffusion rate of oxygen into a biofilm from the solution in bulk reaches equilibrium with the consumption rate of oxygen by endogenous respiration of the immobilized microorganism. The current output values coincident with the DO in the solution in bulk are called an "initial or base current". When a BOD solution is injected into a biosensor system, biodegradable organics diffuse into a biofilm from the solution in bulk. Then, in several minutes the current output reaches another constant current value which is smaller than the initial current, because the diffusion rate of oxygen into a biofilm reaches equilibrium with the enhanced respiration rate of the biofilm by increasing organics. The current output values are called a "peak current". A difference between the initial current and the peak current is proportional to a concentration of immediately biodegradable organics in a sample. From this difference, unknown substrate concentrations are estimated. The determination time is normally 15–20 min followed by 15–60 min recovery time.

2.3 Standard solutions

Currently, the BOD₅ test method adopts glucose and glutamic acid (GGA) as a standard check solution. A standard solution is a mixture of 150 mg glucose/L and 150 mg glutamic

acid/L, and is similar to that obtained with many municipal waste waters. For the 300 mg/L mixed solution, the BOD₅ would be 220 mg/L with standard deviation of 10 mg/L (JIS, 1993). GGA solution is used as a standard solution for calibration of most of previously reported BOD sensors. However, the components of river waters and secondary effluents differ greatly from GGA solution. River waters and effluents usually contain refractory organic compounds, such as humic acid, gum arabic, lignin, tannic acid, and surfactant. Especially, these organic compounds account for over 50% in compositions of secondary effluents according to the publication by Tanaka (Tanaka et al., 1994). Therefore, arbitrarily selected refractory organic compounds, as reported in previously papers (Murakami et al., 1978; Tanaka et al., 1994), were studied. The constituents of artificial wastewater (AWW) per liter of distilled water are as follows: nitrohumic acid, 4.246 mg; gum arabic, 4.696 mg; NaLS, 2.427 mg; tannic acid, 4.175 mg; LAS, 0.942 mg. In this study, The AWW is used as a standard solution for calibration of the *Pseudomonas putida* SG10 BOD sensor. The AWW solution is 3.7 mg/L of BOD₅, and 5.89 mg/L of COD_{MN}, respectively.

2.4 Biofilm

Cells in the stationary phase of growth were harvested by centrifugation at 6000 rpm for 10 min, washed twice with 50 mL of 10 mM phosphate buffer (pH 7.0), and were subsequently resuspended in the same buffer. The biofilm was prepared using an aspirator connected to a syringe filter holder (Advantec, Japan). Calculated amounts (wet cells 40 mg, OD₆₆₀ = 1.7) of the pure culture broth were dropped on a porous cellulose nitrate membrane (20 mm diameter, 0.45 μm pore size, Advantec, Japan). Microorganisms were adsorbed on the membrane by suction, and then another similar membrane was placed on immobilized microorganism membrane and was re-adsorbed by using the equipment above, *i. e.* microorganisms were sandwiched between two porous membranes. The microorganism membrane was washed with 10 mM phosphate buffer. The biofilm was placed on an oxygen electrode, and fixed in place using 200 mesh nylon and an 'O'-ring.

3. Performance of the BOD sensors

3.1 Amperometric microbial BOD sensor

3.1.1 Characterization and response

The oxygen electrode with the biofilm of *P. Putida* SG10 was inserted into the detection chamber containing 50 mL of 10 mM phosphate buffer saturated with air, while continuously stirring with a magnetic bar. The temperature of the detection chamber was maintained at 30°C using a constant temperature water bath. The current output of the oxygen electrode was measured using a digital multimeter (Model TR6840, TakedaRiken, Japan) and an electronic poly recorder (Model EPR-200A, TOA Electronics, Japan).

The values and linear correlation are shown in Fig. 1. Calibration was performed using the response data at the steady state. A linear relationship was observed ranging 0.5 to 10 mg/L BOD. The detection limit was 0.5 mg/L BOD. The response time of the biosensor depended on the BOD level, taking between 2 and 15 min to reach the steady state. For BOD of 1 mg/L, reproducible responses could be obtained within ±10% relative error of the mean value; standard deviation was 0.078 mg/L (n=5). On the other hand, *Trichosporon cutaneum* typically employed in BOD sensors did not grow in AWW culture (data not shown).

The influences of pH and temperature on the response were investigated for BOD of 1 mg/L in 10 mM phosphate buffer. The optimum pH was investigated from pH 4.0 to 9.0. The response rapidly increased to give a maximum at pH 7.0, and then decreased (Fig. 2). It will be caused by the inactivation of *P. putida* at either lower or higher pH values. The optimum temperature was evaluated in the range of 5 to 40°C, and found to be a maximum at 35°C (Fig. 3). Above 35°C, the response decreased slightly, which is probably also caused by the inactivation of the microorganism by heat. In order to prolong the lifetime of the bacteria, a temperature of 30°C was used in the biosensor.

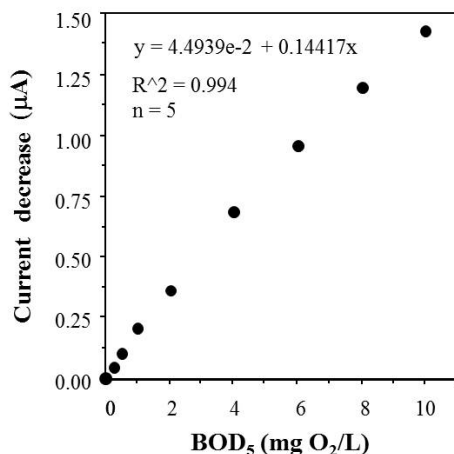

Fig. 1. Correlation between BOD concentration and current decrease using the AWW solution under the optimal conditions.

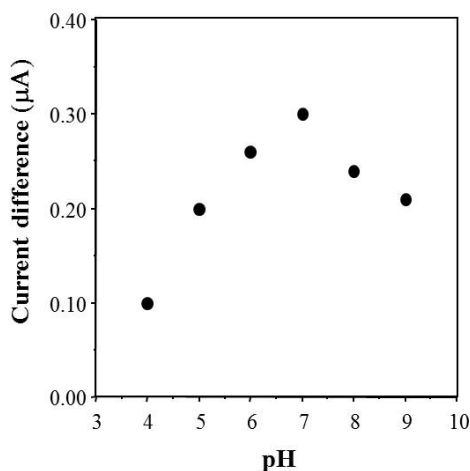

Fig. 2. Influence of pH on the sensor response at 30°C and AWW (1 mg/L BOD).

The stability of the biosensor was determined over 15 min after it had been immersed in the AWW solution (BOD of 1 mg/L), at pH 7.0 and 30°C. The biosensor response was found to be fairly constant over a period of 10 days, with about $\pm 10\%$ fluctuations. The storage stability of the biosensor was examined at 4°C. The biosensor could be stored in buffer solution for 5 months without significant deterioration, but the biosensor had to be pre-conditioned for 1-2 days in the AWW solution (BOD of 1 mg/L) before use, in order to achieve good sensitivity, stability, and reproducibility.

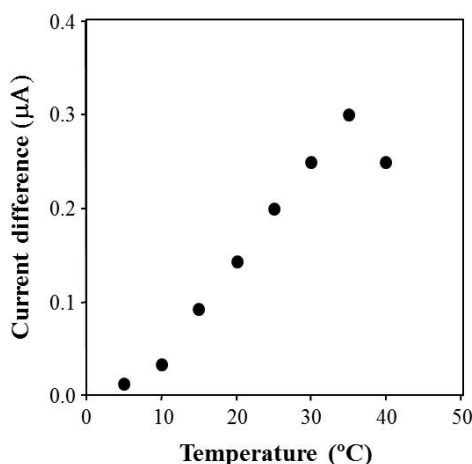

Fig. 3. Influence of temperature on the sensor response at pH 7.0 and AWW (1 mg/L BOD).

3.1.2 Interference on response

The influences of chloride ion and heavy metal ions on the biosensor response were examined in 10 mM phosphate buffer (pH 7.0), at BOD of 1 mg/L. Here, NaCl was used as the chloride ion source. The biosensor response was not dramatically affected by chloride ion concentration of up to 1000 mg/L. Therefore, the biosensor could be applied to analyze environmental samples of high sodium chloride concentrations.

Most river waters contain various heavy metal ions like Fe^{3+} , Cu^{2+} , Mn^{2+} , Zn^{2+} , and Cr^{3+} , and the presence of these heavy metal ions in river waters may interfere with the activity of the microorganisms (Collins & Stotzky, 1989). The influence of heavy metal ions on the biosensor response was investigated at each 1 mg/L, because the highest concentration of these ions in polluted Japanese rivers should be below 1 mg/L (River Bureau, 1992). The results revealed that Fe^{3+} , Cu^{2+} , Mn^{2+} , Zn^{2+} , and Cr^{3+} have no effects on the response of the biosensor.

3.1.3 Application

The BOD sensor was used to determine the BOD of various river waters in Japan, and the values obtained were compared with the BOD₅ method. As shown in Figure 4, the results obtained by the biosensor are generally somewhat lower than the values obtained by the BOD₅ method. This behavior is attributable to the presence of compounds which are not easily assimilable to the biosensor in such a short time.

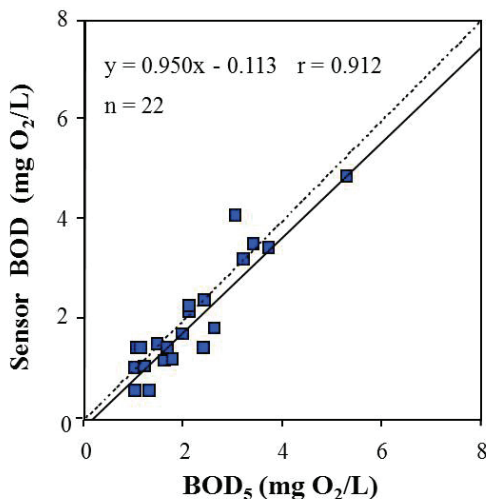

Fig. 4. Comparison of BOD values estimated by the sensor with those determined by the 5-day method for various river waters.

3.2 Highly sensitive BOD sensors

The BOD sensor showed the very good response in the range of AWW up to 10 mg/L. The biosensor with *P. putida* SG10 was used to evaluate BOD values of various environmental samples. The biosensor could determine low BOD values, 1–10 mg/L in river waters. In analyses of river waters, however, this biosensor often displayed low values compared with the BOD₅ as well as other BOD sensors (Hikuma et al., 1979; Hyun et al., 1993; Ohki et al., 1994; Yang et al., 1996). The results would show that refractory organics in river waters are uneasily assimilable to the biofilm in such a short measuring time. To overcome this problem, pretreatment by photocatalytic oxidation or ozonation was introduced in the biosensor system (Chee et al., 1999a, 2001, 2005; Chee et al., 2007).

3.2.1 Photocatalytic BOD sensor

In 1972, Fujishima and Honda discovered the photocatalytic splitting of water which could be decomposed into hydrogen and oxygen over an illuminated titanium dioxide semiconductor electrode (Fujishima & Honda, 1972). With the help of this event, photoelectrochemistry has expanded into a formidable field encompassing solar energy conversion (Bard, 1982), photocatalysis (Fujihara et al., 1981; Hoffmann et al., 1995; Linsebigler et al., 1995), decomposition of agrochemical (Lu & Chen, 1997), air and water purification (Bolduc & Anderson, 1997; Rodriguez et al., 1996). In the photochemical oxidation method, short wavelength UV-C (< 280 nm) light is commonly employed (Prousek, 1996). On the other hand, photocatalytic experiments with titanium dioxide usually use long wavelength UV-A (> 315 nm) light (Bahnemann et al., 1991; Egerton & King, 1979; Hashimoto et al., 1984). Figure 5 shows a general schematic representation of the degradation of organic compound in aqueous solution by electron-hole (e^-h^+) formation at the surface of an illuminated titanium dioxide particle (Rajeshwar, 1995). When titanium dioxide is illuminated with band gap energy of greater than 3.2 eV (380 nm), a photon

excites an electron from the valence band (VB) to the conduction band (CB) and leaves an electronic vacancy commonly referred to as a hole in the VB. The electron in the CB can be transferred to adsorbed H^+ , O_2 or the chlorinated pollutant initiating various reactions. The hole in the VB can react with surface-bound water, hydroxide groups, anions and organic substrate. Therefore organic compounds in aqueous solution are split to the formation of compounds of lower molecular weight by photocatalytic oxidation. The result will increase the sensitivity of the BOD sensor because organic compounds of lower molecular weight are more readily biodegradable through the biofilm.

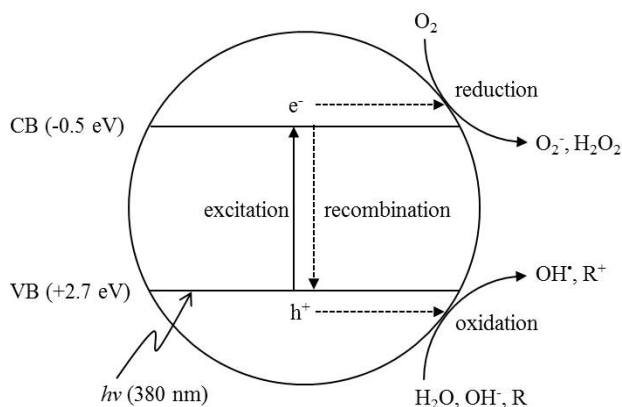

Fig. 5. Schematic diagram of simplified mechanism for the photoactivation of a titanium dioxide particle.

3.2.1.1 Flow system with semiconductor photocatalysis and response

The flow system was developed to monitor continuously in river waters, as schematically illustrated in Figure 6. The TiO_2 -AWW solutions were illuminated from 0 to 5 min by black-light tube at room temperature. The slope of current was a maximum at irradiation time 4 min.

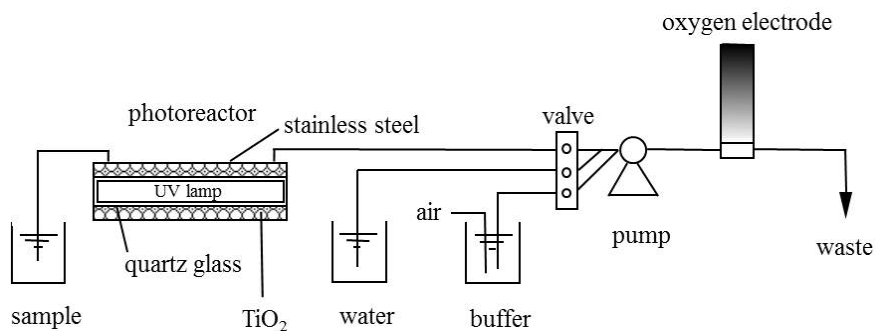

Fig. 6. The photocatalytic BOD sensor of the flow system using pretreatment by photocatalysis. A column size: ID 22 x OD 34 x L 205 mm, total volume: 63 mL, amount of TiO_2 : 47 g, a UV lamp: a 6W black, flow rate: 3 mL/min.

The flow rate was 3 mL/min (Chee et al., 2005). Figure 7 showed the comparison of the biosensor responses with and without photocatalysis. At BOD of 1 mg/L, the biosensor responses obtained with and without photocatalysis were 0.20 and 0.15 μ A, respectively. The slope with photocatalysis, up to 10 mg/L BOD, increased 1.39 fold that without photocatalysis. However, the biosensor response to BOD of 0.5 mg/L was hardly difference in between with and without photocatalysis. The results would indicate that organic compounds in AWW solution would be adsorbed on surface of TiO₂ particle when the solution flowed into a photoreactor, and so some degraded organic compounds may stream to a cell on the biofilm. Consequently, the biosensor would give the low response, whereas, over 1 mg/L BOD, the solution from a photoreactor outlet after photocatalysis was fully to give high response to the biosensor. Relative standard deviations with and without photocatalysis at BOD of 2 mg/L were all both 12.0% ($n=5$).

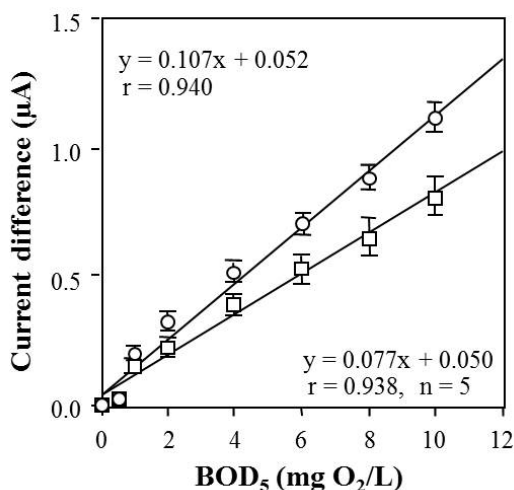
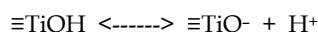
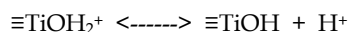

Fig. 7. Comparison of the sensor responses with and without photocatalytic oxidation using AWW in the flow system. □: without photocatalysis, ○: with photocatalysis.

The effect of the initial pH on the degradation of the photocatalytic AWW solution was examined at four different pH values between pH 5.0-8.0. The effectivity of the photocatalytic degradation is characterized by the current output. The current output is hardly changed to pH 6.0, but increased with rising pH over pH 6.0. It is well known that the surfaces of metal oxides in aqueous solution are covered with hydroxyl groups (Stumm & Morgan, 1981). Surface groups of a metal oxide are amphoteric and the surface acid-base equilibria are known as follows:



where $\equiv\text{TiOH}$ represents the "titanol" surface group. The neutral surface species, TiOH is predominant over a broad range of pH 3 to 10. At below the pH of zero point of charge, pH_{zpc} , the TiO₂ surface becomes a net positive charge because of the increasing fraction of

total surface sites present as $\equiv\text{TiOH}_2^+$. On the other hand, at above pH_{zpc} the surface has a net negative charge because of a significant fraction of total surface sites present as $\equiv\text{TiO}^-$. The interaction with cationic electron donors and electron acceptors will be favored for heterogeneous photocatalytic activity at high pH ($> \text{pH}_{zpc}$), while anionic electron donors and acceptors will be favored at low pH ($< \text{pH}_{zpc}$). AWW solution is mixing compounds. The compounds may be significant photocatalytic activity at high pH. The organic compounds would be also decomposed by hydroxyl radicals which are very strong oxidant. The hydroxyl radicals mainly yield with hydroxide ions in the reaction of h^+ of the VB (Turchi & Ollis, 1990).

3.2.1.2 Lifetime of TiO_2

Lifetime of TiO_2 was investigated using AWW solution, BOD of 10 mg/L by TOC analyzer. As shown in Figure 8, TOC dramatically decreased until 40 times, and had 50% of the initiation at about 70 times. With 40 times or more, a decrease of TOC/TOC_0 with UV irradiation was observed. Because organic compounds streaming through a photoreactor may be quickly adsorbed by diffusing on the surface of TiO_2 particles (Bandala et al., 2002; Robert & Weber, 2000). The ratio of TOC/TOC_0 without UV irradiation also decreased 10-15%. Consequently, the degradation of organic compounds fell on the surface of TiO_2 with photocatalysis. Over 70 times, especially, the ratio of TOC/TOC_0 extremely decreased. It suggests that the surface of titanium dioxide particles might be saturate with organic compounds by repetition of the sample introduction. The detection time was 20 min, and sequent determination was carried out without washing. Determining real samples, half-lifetime of TiO_2 would be predicted longer because of a repetition of determining and washing.

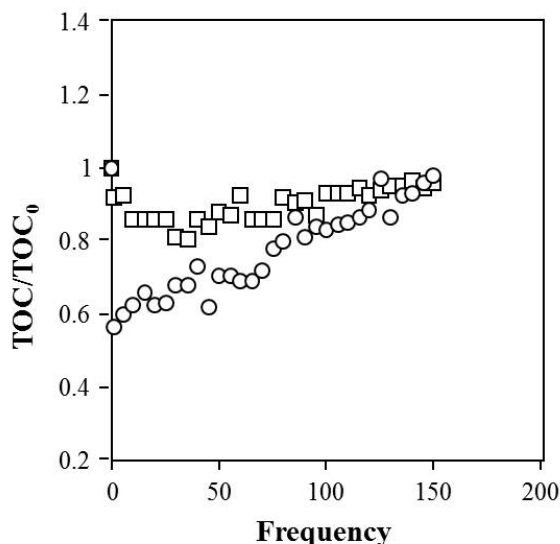

Fig. 8. Photocatalytic oxidation rates of TiO_2 using AWW in the flow system. TOC_0 : AWW non-through a photoreactor, TOC : AWW through a photoreactor, \square : without irradiation, \circ : with irradiation (*i. e.* pretreatment by photocatalysis.).

3.2.1.3 Effects of free radicals and H₂O₂

The yield of hydrogen peroxide with photocatalysis was investigated in AWW solution (10 mg/L) that passed through a photoreactor. Organic compounds react on the surface of TiO₂ under UV irradiation, and many free radicals and hydrogen peroxide are produced. These were toxicity to microorganisms (Bilinski, 1991; Brandi et al., 1989a). Microorganisms exposed under hydrogen peroxide and/or oxy-radicals were killed or changed its morphology. Half-lifetime of hydroxyl radical, HO• and superoxide, O₂^{•-} were 10⁻⁹ s at 1M and 2.5 s at 1 μM, respectively, while hydrogen peroxide was a relatively stable molecule in water (Pryor, 1986).

H₂O₂ yielded using AWW solution (10 mg/L) through a photoreactor under irradiating UV was quantitatively analyzed by spectrofluorometer (JASCO Co. Ltd, FP-770F, Japan). Excitation and emission of scopoletin were 366 and 460 nm, respectively. H₂O₂ of 3.56 μM was yielded in AWW solution that passed through a photoreactor under UV irradiation. H₂O₂ of 1.75 mM was approximately equitoxic in bacteria, as a previously described paper (Brandi et al., 1989b). Although bacteria are exposed to active oxygen or other radicals, they have evolved mechanisms of defense against oxidative stresses that can damage most cellular components, including proteins, lipids, and DNA. To overcome such oxidative stresses, bacteria have genes such as *soxR*, *soxS* for superoxide radical, and *oxyR*, *dps* for H₂O₂ and organic peroxides (Nair & Finkel, 2004). Dps protein, especially, can neutralize toxic peroxides through its ferroxidase activity. Bacteria also can repair oxidatively damaged DNA using genes such as *recA*, *polA*, and *xthA*. Accordingly, bacteria would be not affected in stress environmental of very low concentrations. Therefore, the concentration would not give the fluctuation in the sensor response. As shown in Figure 6, a photoreactor to the biofilm on the oxygen electrode takes 3 min when the flow rate was 3 mL/min. Other free radicals did not give the influences on the sensor response. The results showed that free radicals will not affect microorganisms in the biofilm on the oxygen electrode because their lifetime was extremely short.

3.2.2 Ozone catalytic BOD sensor

For the elimination of refractory organics from industrial wastewater and municipal effluents, ozone pretreatment has been studied by numerous investigators (Gulyas, 1997; Perkowski et al., 1996; Unkroth et al., 1997). Ozonolysis has been widely applied either to eliminate or to decompose refractory organic compounds in industrial wastewater and municipal effluents (Gulyas et al., 1995; Widsten et al., 2004). During self-decomposition of ozone in aqueous solutions, free radicals yielded are used as powerful oxidants to cleave organic compounds in environmental samples (Staehelin & Holgné, 1982). The ozonation of organic compounds in aqueous solutions generates lower molecular weight than the parent compounds, and the decomposed organic compounds would assimilate faster into microbes immobilized on the membrane. The result will increase the sensitivity of the biosensor. Here, for higher sensitivity of the biosensor, ozone pretreatment was introduced in the biosensor (Chee et al., 1999a; Chee et al., 2007).

3.2.2.1 Stopped-flow system with ozonolysis and response

The stopped-flow BOD sensor consists of an ozonizer (ON-12, Nippon ozone, Japan), an oxygen probe (Able Co., Japan) with the biofilm, a digital meter (Model TR6840, TakedaRiken, Japan) and an electronic recorder (Model EPR-200A, TOA Electronics, Japan) (Fig. 9).

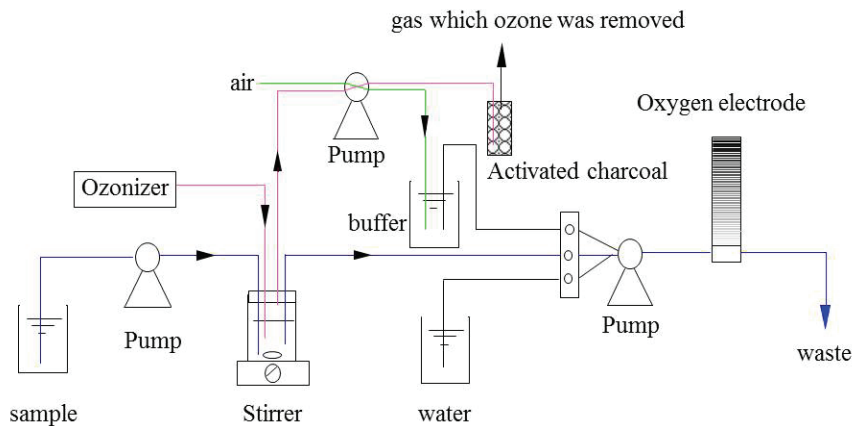

Fig. 9. Schematic diagram of the stopped-flow system of the BOD sensor using pretreatment with ozone.

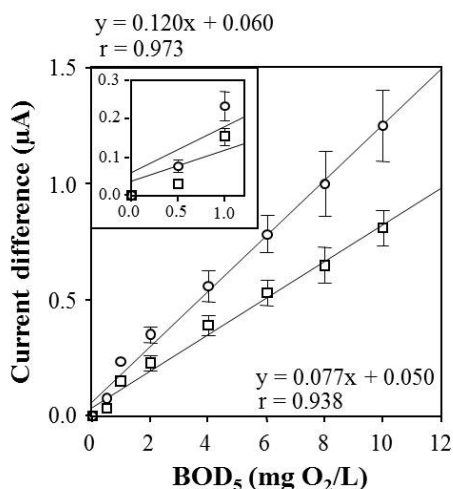

Fig. 10. The sensor responses before and after ozonation in the stopped-flow system under the optimal conditions. □: before ozonation, ○: after ozonation.

An ozonizer was installed to pretreat environmental samples. The biosensor responses before and after ozonation on AWW solutions were investigated in the range of 0 to 10 mg/L BOD (Fig. 10). At BOD of 1 mg/L, the biosensor responses obtained before and after ozonation were 0.15 and 0.24 µA, respectively. As shown in the window in Figure 10, the response before ozonation could be detected to 0.5 mg/L BOD, but the response had low reproducibility. On the other hand, the response after ozonation was 2.7-fold higher than that before; moreover, its reproducibility was increased. Up to 10 mg/L BOD, the slope of the biosensor responses after ozonation was 1.56-fold that before ozonation. Relative standard deviations with and without pretreatment at BOD of 2 mg/L were both 12.0%

($n = 5$). The response time of the sensor was generally varied depending on the concentrations of BOD in the samples. In the range of the determined concentrations of BOD, however, the response time did not exceed 5 min. This indicates that the organic compounds in AWW solution degraded with ozone were easily assimilated by the microorganism on the biofilm. When the samples were treated with ozone in a pretreatment reactor, before pumping the samples into the flow cell with the biofilm, they were vigorously stirred using a magnetic bar over 20 min to completely remove the excess ozone.

3.2.2.2 Effect of ozonation time

Figure 11 showed the changes of TOC removal rates and pH with ozonation time in the range of 0 to 10 min in AWW solutions. The ozonation of AWW solutions was carried out by $25.9 \text{ g N}^{-1} \text{ m}^{-3}$ ozone at room temperature. TOC removal rates were defined as the ratio of TOC values before and after ozonation. TOC removal rates per time unit showed a maximum value at 3 min, and then slightly decreased. Results from Figure 11 indicate that there is an optimal ozonation time to degrade the maximum amount of AWW solution. Therefore, in subsequent experiments, ozonation times of the samples were adjusted to 3 min. During ozonation, a decrease in pH and an increase in variation followed by the steady state was observed, indicating the formation of ionic substances. Decolorization of the pale yellow AWW solution occurred after 3 minutes ozonation, and clear AWW solution was obtained in 10 minutes.

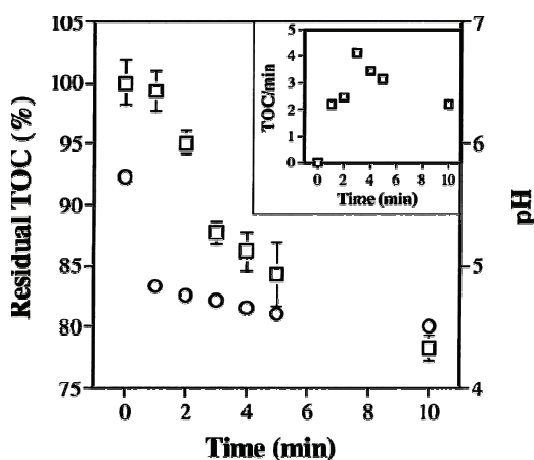
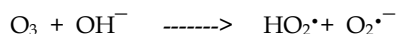

Fig. 11. Effect of ozonation time on pH and TOC removal rates in AWW solutions. AWW: 16.485 mg/L , concentration of ozone in the feed gas: $25.9 \text{ g N}^{-1} \text{ m}^{-3}$, temperature: room temperature, \square : TOC, \circ : pH. Error bars represent the standard deviation of 6 experiments.

3.2.2.3 Effect of pH and ozone concentration

The effects of initial pH on the ozonation rate of AWW solutions were investigated ranging 5.0 to 9.0. Owing to the strong effect of hydroxide ions on self-decomposition of ozone (Stahelin & Holgné, 1982), pH would be the most important parameter of ozonation process. TOC removal rates increased while rising initial pH. TOC removal rates at initial pH 7.0 were ca. 10 %, this value being twice that at pH 5.0. The ozonation rates are larger at

higher pH values (Staehelin & Holgné, 1982), as predicted by the initial reaction of ozonation (Weiss, 1935):



pH 7.0 was selected as working pH for further experiments. The reacting organic compounds can have different reactivities at different pH values because of their dissociation and electron activities. The reaction between ozone and organic compounds in aqueous solutions is known to be dependent on the pH value of the solution (Nadezhdin, 1988; Staehelin & Holgné, 1982). Ozone decomposed relatively well in the high pH region, where molecular ozone selectively reacts with unsaturated bonds in the molecule of organic compounds to produce ketones, carboxylic acid, alcohols, etc. Various free radicals yield from self-decomposition of ozone, like semiconductor photocatalysis, in aqueous solutions. It is well known that free radicals are toxic to bacteria since they can change the morphology of bacteria and damage most cellular components containing DNA, proteins, and lipids (Bilinski, 1991; Brandi et al., 1989a). In this work, however, bacteria on the biofilm will not be influenced by free radicals because only samples removed under controlled conditions of the ozone were pumped into the flow cell with the biofilm. Even if free radicals were residual in the samples pretreated with ozone, their functions immediately terminated due to their extremely short lifetimes, e.g., 10^{-9} sec for half-life of hydroxyl radical (Pryor, 1986), during the transfer of the samples from the pretreatment reactor to the flow cell with the biofilm.

Figure 12 showed the effect of ozone concentration on TOC removal rates. The feed ozone dose was investigated from 0 to $51.5 \text{ g N}^{-1} \text{ m}^{-3}$, and the AWW solutions were adjusted to pH 7.0. As shown in Figure 12, TOC removal rates rapidly increased until reaching a plateau for $42.4 \text{ g N}^{-1} \text{ m}^{-3}$ ozone. TOC removal rates to 42.4 and $51.5 \text{ g N}^{-1} \text{ m}^{-3}$ ozone had values of about 17% and 18%, respectively.

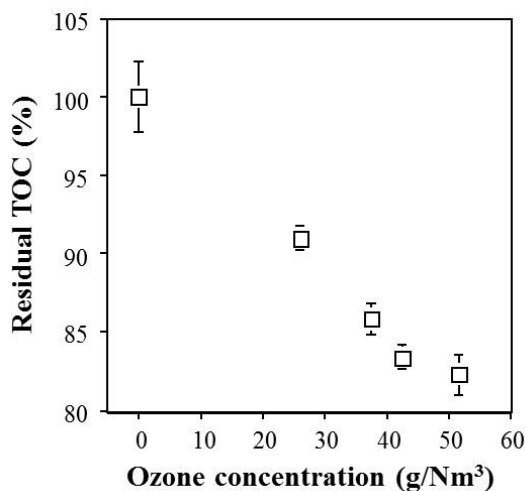

Fig. 12. Effect of ozone concentration on TOC removal in AWW solutions. Pretreatment time: 3 min, pH: 7.0, temperature: room temperature.

3.2.3 Application

The photocatalytic biosensor and stopped-flow system were used to evaluate BOD in environmental samples from various rivers before and after pretreatment. Environmental samples for the test were collected from 21 various rivers that were drinking water sources. The BOD levels obtained before and after pretreatment were compared with the conventional BOD₅ method. The BOD values evaluated without pretreatment showed lower than those obtained by the BOD₅, while the BOD values estimated with photocatalysis or ozonolysis were either a little low or the same to the BOD₅. The slope and correlation (r) between the photocatalytic biosensor and the conventional method were 0.908 and 0.983, respectively. The BOD levels obtained before and after ozonation were also compared with the BOD₅ method (Fig. 13). The slopes of the biosensor were 0.849 before ozonation and 0.933 after ozonation, respectively. The slope with pretreatment increased to approximately 17% in comparison with that without pretreatment. The correlation factor (r) between the stopped-flow system and the BOD₅ method was 0.989. The results indicate that the biosensors using pretreatments improved the estimation of BOD in environmental samples.

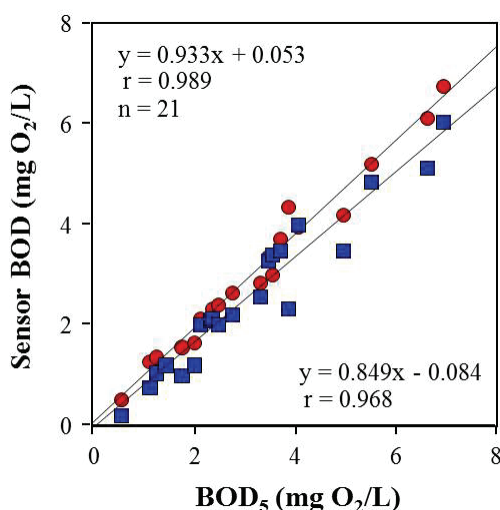

Fig. 13. Comparison of BOD values in river waters by with and without ozonation in the stopped-flow system. ■: without ozonation, ●: with ozonation.

4. Conclusions

The BOD sensor using *Trichosporon cutaneum* can be used in industrial wastewater, but not for river waters and secondary effluents due to no growth of *T. cutaneum* in AWW culture. The BOD sensor using *P. putida* SG10 was described to be suitable for determining low BOD values in river waters. BOD measurements could be determined at pH 7.0, and 30°C. The biosensor responses were observed a linear relationship in the range of 0.5 to 10 mg/L BOD. The detection limit and time were 0.5 mg/L BOD and less than 15 min, respectively, compared with the BOD₅ test method. Especially, the response time by ozonolysis was only 5 min. The biosensor system showed negligible response to chloride and heavy metal ions,

and had good sensitivity, stability and reproducibility. Pretreatment by photocatalysis or ozonolysis was introduced to increase the sensitivity of the biosensor. When determining environmental samples by pretreatments, the biosensor responses showed the increased levels, and the systems must be the advanced method for the evaluation of low BOD in rivers.

5. References

- APHA. (1986). *Standard Methods for the Examination of Waters and Wastewater*, 16th ed. American Public Health Association, Washington, DC, pp. 525-531.
- Bahnemann, D., Bockelmann, D. & Goslich, R. (1991). Mechanistic studies of water detoxification in illuminated TiO₂ suspensions, *Solar Energy Materials* Vol. 24: 564-583.
- Bandala, E.R., Gelover, S., Leal, M.T., Arancibia-Bulnes, C., Jimenez, A. & Estrada, C.A. (2002). Solar photocatalytic degradation of aldrin, *Catalysis Today* Vol. 76: 189-199.
- Bard, A.J. (1982). Design of semiconductor photoelectrochemical system for solar energy conversion, *J. Phys. Chem.* Vol. 86: 172-177.
- Bilinski, T. (1991). Oxygen toxicity and microbial evolution, *BioSystems* Vol. 24: 305-312.
- Bolduc, L. & Anderson, W.A. (1997). Enhancement of the biodegradability of model wastewater containing recalcitrant or inhibitory chemical compounds by photocatalytic pre-oxidation, *Biodegradation* Vol. 8: 237-249.
- Brandi, G., Cattabeni, F., Albano, A. & Cantoni, O. (1989a). Role of hydroxyl radicals in *Escherichia coli* killing induced by hydrogen peroxide, *Free Rad. Res. Comms.* Vol. 6: 47-55.
- Brandi, G., Fiorani, M., Pierotti, C., Albano, A., Cattabeni, F. & Cantoni, O. (1989b). Morphological changes in *Escherichia coli* cells exposed to low or high concentrations of hydrogen peroxide, *Microbiol. Immunol.* Vol. 33: 991-1000.
- Chan, C., Lehmann, M., Tag, K., Lung, M., Kunze, G., Riedel, K., Gruendig, B. & Renneberg, R. (1999). Measurement of biodegradable substances using the salt-tolerant yeast *Arxula adeninivorans* for a microbial sensor immobilized with poly (carbamoyl) sulfonate (PCS): Part I: construction and characterization of the microbial sensor, *Biosens. Bioelectron.* Vol. 14: 131-138.
- Chee, G.-J., Nomura, Y., Ikebukuro, K. & Karube, I. (1999a). Development of highly sensitive BOD sensor and its evaluation using preozonation, *Anal. Chim. Acta* Vol. 394: 65-71.
- Chee, G.-J., Nomura, Y., Ikebukuro, K. & Karube, I. (2001). Biosensor for the evaluation of biochemical oxygen demand using photocatalytic pretreatment, *Sensors and Actuators B* Vol. 80: 15-20.
- Chee, G.-J., Nomura, Y., Ikebukuro, K. & Karube, I. (2005). Development of photocatalytic biosensor for the evaluation of biochemical oxygen demand, *Biosens. Bioelectron.* Vol. 21: 67-73.
- Chee, G.-J., Nomura, Y. & Karube, I. (1999b). Biosensor for the estimation of low biochemical oxygen demand, *Anal. Chim. Acta* Vol. 379: 185-191.

- Chee, G.J., Nomura, Y., Ikebukuro, K. & Karube, I. (2000). Optical fiber biosensor for the determination of low biochemical oxygen demand, *Biosens. Bioelectron.* Vol. 15: 371-376.
- Chee, G.J., Nomura, Y., Ikebukuro, K. & Karube, I. (2007). Stopped-flow system with ozonizer for the estimation of low biochemical oxygen demand in environmental samples, *Biosens. Bioelectron.* Vol. 22: 3092-3098.
- Collins, Y.E. & Stotzky, G. (1989). Factors affecting the toxicity of heavy metals to microbes, In: *Metal ions and Bacteria*, Beveridge, T.J. & Doyle, R.J., (eds.), pp. 31-90, John Wiley & Sons, New York.
- Egerton, T.A. & King, C.J. (1979). The influence of light intensity on photoactivity in TiO₂ pigmented systems, *J. Oil. Chem. Assoc.* Vol. 62: 386-391.
- Fujihara, M., Satoh, Y. & Osa, T. (1981). Heterogeneous photocatalytic oxidation of aromatic compounds on TiO₂, *Nature* Vol. 293: 206-208.
- Fujishima, A. & Honda, K. (1972). Electrochemical photolysis of water at a semiconductor electrode, *Nature* Vol. 238: 37-38.
- Galindo, E., Garcia, J.L., Torres, L.G. & Quintero, R. (1992). Characterization of microbial membranes used for the estimation of biochemical oxygen demand with a biosensor, *Biotechnol. Tech.* Vol. 6: 399-404.
- Gulyas, H. (1997). Processes for the Removal of Recalcitrant Organics from Industrial Wastewaters, *Wat. Sci. Tech.* Vol. 36: 9-16.
- Gulyas, H., Bismarck, R.V. & Hemmerling, L. (1995). Treatment of Industrial Wastewater with Ozone/Hydrogen Peroxide, *Wat. Sci. Tech.* Vol. 32: 127-134.
- Hashimoto, K., Kawai, T. & Sakata, T. (1984). Photocatalytic reactoins of hydrocarbons and fossil fuels with water: Hydrogen production and oxidation, *J. Phys. Chem.* Vol. 88: 4083-4088.
- Hikuma, M., Suzuki, H., Yasuda, T., Karube, I. & Suzuki, S. (1979). Amperometric estimation of BOD by using living immobilized yeasts, *Eur. J. Appl. Microb. Biotechnol.* Vol. 8: 289-297.
- Hoffmann, M.R., Martin, S.T., Choi, W. & Bahnemann, D.W. (1995). Environmental application of semiconductor photocatalysis, *Chem. Rev.* Vol. 95: 69-96.
- Hyun, C.K., Tamiya, E., Takeuchi, T., Karube, I. & Inoue, N. (1993). A novel BOD sensor based on bacterial luminescence, *Biotechnol. Bioeng.* Vol. 41: 1107- 1111.
- Jiang, Y., Xiao, L.L., Zhao, L., Chen, X., Wang, X. & Wong, K.Y. (2006). Optical biosensor for the determination of BOD in seawater, *Talanta* Vol. 70: 97-103.
- JIS. (1993). *Japanese Industrial Standard Committee Testing Methods for Industrial Waste Water*, pp. 48-53 [in Japanese].
- Karube, I., Matsunaga, T. & Suzuki, S. (1977a). A new microbial electrode for BOD estimation, *J. Solid-Phase Biochem.* Vol. 2: 97-104.
- Karube, I., Mitsuda, S., Matsunaga, T. & Suzuki, S. (1977b). A Rapid Method for Estimation of BOD by using Immobilized Microbial Cells, *J. Ferment. Technol.* Vol. 55: 243-248.
- Karube, I., Yokoyama, K., Sode, K. & Tamiya, E. (1989). Microbial BOD sensor utilizing thermophilic bacteria, *Anal. Lett.* Vol. 22: 791-801.
- Kim, M.-N. & Kwon, H.-S. (1999). Biochemical oxygen demand sensor using *Serratia marcescens* LSY 4, *Biosens. Bioelectron.* Vol. 14: 1-7.

- Kulys, J. & Kadziauskiene, K. (1980). Yeast BOD sensor, *Biotechnol. Bioeng.* Vol. 22: 221-226.
- Kwok, N.-Y., Dong, S., Lo, W. & Wong, K.-Y. (2005). An optical biosensor for multi-sample determination of biochemical oxygen demand (BOD), *Sensors and Actuators B* Vol. 110 (2): 289-298.
- Leblanc, P.J. (1974). Review of rapid BOD test methods, *J. WPCF* Vol. 46. 9: 2202-2208.
- Lehmann, M., Chan, C., Lo, A., Lung, M., Tag, K., Kunze, G., Riedel, K., Gruendig, B. & Renneberg, R. (1999). Measurement of biodegradable substances using the salt-tolerant yeast *Arxula adenivorans* for a microbial sensor immobilized with poly (carbamoyl) sulfonate (PCS): Part II: application of the novel biosensor to real samples from coastal and island regions, *Biosens. Bioelectron.* Vol. 14: 295-302.
- Li, Y.-R. & Chu, J. (1991). Study of BOD microbial sensors for waste water treatment control, *Appl. Biochem. Biotechnol.* Vol. 28: 855-863.
- Lin, L., Xiao, L.L., Huang, S., Zhao, L., Cui, J.S., Wang, X.H. & Chen, X. (2006). Novel BOD optical fiber biosensor based on co-immobilized microorganisms in ormosils matrix, *Biosens. Bioelectron.* Vol. 21: 1703-1709.
- Linsebigler, A.L., Lu, G. & J. T. Yates, J. (1995). Photocatalysis on TiO₂ surfaces: principles, mechanism, and selected results, *Chem. Rev.* Vol. 95: 735-758.
- Lu, M.-C. & Chen, J.-N. (1997). Pretreatment of pesticide wastewater by photocatalytic oxidation, *Wat. Sci. Tech.* Vol. 36: 117-122.
- Murakami, K., Hasegawa, K., Watanabe, H. & Komori, K. (1978). Biodegradation of organic substances by biological treatment and in natural waters, *Public Works Research Institute Technical Memorandum* NO. 1421 [in Japanese with English abstract].
- Nadezhdin, A.D. (1988). Mechanism of Ozone Decomposition in Water. The Role of Termination, *Ind. Eng. Chem. Res.* Vol. 27: 548-550.
- Nair, S. & Finkel, S.E. (2004). Dps protects cells against multiple stresses during stationary phase, *J. Bacteriol.* Vol. 186: 4192-4198.
- Ohki, A., Shinohara, K., Ito, O., Naka, K. & Maeda, S. (1994). A BOD sensor using *Klebsiella oxytoca* AS1, *J. Environ. Anal. Chem.* Vol. 56: 261-269.
- Perkowski, J., Kos, L. & Ledakowicz, S. (1996). Application of Ozone in Textile Wastewater Treatment, *Ozone Sci. Eng.* Vol. 18: 73-85.
- Prousek, J. (1996). Advanced oxidation processes for water treatment. Photochemical processes, *Chem. Listy* Vol. 90: 307-315.
- Pryor, W.A. (1986). Oxy-radicals and related species: Their formation, lifetimes, and reactions, *Ann. Rev. Physiol.* Vol. 48: 657-667.
- Rajeshwar, K. (1995). Photoelectrochemistry and the environment, *J. App. Electrochem.* Vol. 25: 1067-1082.
- Reiss, M., Tari, A. & Hartmeier, W. (1993). BOD-biosensor basing on an amperometric oxygen electrode covered by *Lipomyces kononenkoae*, *Bioengineering* Vol. 9: 87.
- Riedel, K. (1998). Application of biosensors to environmental samples, In: *Commercial biosensors: applications to clinical, bioprocess, and environmental samples*, Ramsay, G., (ed.), pp. 267-295, John Wiley & Sons Inc., New York.
- Riedel, K., Lange, K.P., Stein, H.J., Kuhn, M., Ott, P. & Scheller. (1990). A microbial sensor for BOD, *Water Res.* Vol. 24: 883-887.
- Riedel, K., Renneberg, R., Kuhn, M. & Scheller, F. (1988). A fast determination of BOD using microbial sensor, *Appl. Microb. Biotechnol.* Vol. 28: 316-318.

- River Bureau. (1992). *Annual report on river water quality in Japan*. River Bureau, Japanese Ministry of Construction, Tokyo [in Japanese].
- Robert, D. & Weber, J.V. (2000). Study of adsorption of dicarboxylic acids on titanium dioxide in aqueous solution, *Adsorption* Vol. 6: 175-178.
- Rodriguez, S.M., Richter, C., Galvez, J.B. & Vincent, M. (1996). Photocatalytic degradation of industrial residual waters, *Solar Energy* Vol. 56: 401-410.
- Sakaguchi, T., Kitagawa, K., Ando, T., Murakami, Y., Morita, Y., Yamamura, A., Yokoyama, K. & Tamiya, E. (2003). A rapid BOD sensing system using luminescent recombinants of *Escherichia coli*, *Biosens. Bioelectron.* Vol. 19: 115-121.
- Sakai, Y., Abe, N., Takeuchi, S. & Takahashi, F. (1995). BOD sensor using magnetic activated sludge, *J. Ferment. Bioeng.* Vol. 80: 300-303.
- Sangeetha, S., Sugandhi, G., Murugesan, M., Madhav, V.M., Berchmans, S., Rajasekar, R., Rajasekar, S., Jeyakumar, D. & Rao, G.P. (1996). *Torulopsis candida* based sensor for the estimation of biochemical oxygen demand and its evaluation, *Electroanalysis* Vol. 8: 698-701.
- Seo, K.S., Choo, K.H., Chang, H.N. & Park, J.K. (2009). A flow injection analysis system with encapsulated high-density *Saccharomyces cerevisiae* cells for rapid determination of biochemical oxygen demand, *Appl. Microbiol. Biotechnol.* Vol. 83: 217-223.
- Staelin, J. & Holgné, J. (1982). Decomposition of Ozone in Water: Rate of Initiation By Hydroxide Ions and Hydrogen Peroxide, *Environ. Sci. Technol.* Vol. 16: 676-681.
- Stand, S.E. & Carlson, D.A. (1984). Rapid BOD measurement for municipal wastewater samples using a biofilm electrode., *JWPCF* Vol. 56: 464-467.
- Stumm, W. & Morgan, J.J. (1981). The surface chemistry of oxides, hydroxides, and oxide mineral, In: *Aquatic Chemistry*, 2nd ed. pp. 625-640, John Wiley & Sons, New York.
- Tan, T.C., Neoh, K.G. & Li, F. (1992). Microbial membrane-modified dissolved oxygen probe for rapid biochemical oxygen demand measurement, *Sensors and Actuators B* Vol. 8: 167-172.
- Tan, T.C. & Wu, C. (1999). BOD sensors using multi-species living or thermally killed cells of a BODSEED microbial culture, *Sensors and Actuators B* Vol. 54: 252-260.
- Tanaka, H., Nakamura, E., Minamiyama, Y. & Toyoda, T. (1994). BOD biosensor for secondary effluent from wastewater treatment plants, *Wat. Sci. Tech.* Vol. 30: 215-227.
- Turchi, C.S. & Ollis, D.F. (1990). Photocatalytic degradation of organic water contaminants: Mechanisms involving hydroxyl radical attack, *J. Catalysis* Vol. 122: 178-192.
- Unkroth, A., Wagner, V. & Sauerbrey, R. (1997). Laser-Assisted Photochemical Wastewater Treatment, *Wat. Sci. Tech.* Vol. 35: 181-188.
- Villalobos, P., Acevedo, C.A., Albornoz, F., Sanchez, E., Valdes, E., Galindo, R. & Young, M.E. (2010). A BOD monitoring disposable reactor with alginate-entrapped bacteria, *Bioprocess Biosyst. Eng.* Vol. 33: 961-970.
- Weiss, J. (1935). Investigations on the Radical HO₂ in Solution, *Trans. Farad. Soc.* Vol. 31: 668-681.
- Widsten, P., Hortling, B. & Poppius-Levlin, K. (2004). Ozonation of conventional kraft and SuperBatch residual lignins in methanol/water and water, *Holzforschung* Vol. 58: 363-368.

- Yang, Z., Suzuki, H., Sasaki, S. & Karube, I. (1996). Disposable sensor for biochemical oxygen demand, *Appl. Microbiol. biotechnol.* Vol. 46: 10-14.
- Yang, Z., Suzuki, H., Sasaki, S., McNiven, S. & Karube, I. (1997). Comparison of the dynamic transient- and steady-state measuring methods in a batch type BOD sensing system, *Sensor and Actuators B* Vol. 45: 217-222.
- Yoshida, N., Yano, K., Morita, T., McNiven, S.J., Nakamura, H. & Karube, I. (2000). A mediator-type biosensor as a new approach to biochemical oxygen demand estimation, *Analyst* Vol. 125: 2280-2284.