

Plastic Analysis
3rd Year
Structural Engineering

2009/10

Dr. Colin Caprani

Contents

1. Introduction	4
1.1 Background.....	4
2. Basis of Plastic Design.....	5
2.1 Material Behaviour	5
2.2 Cross Section Behaviour	7
2.3 Plastic Hinge Formation	23
3. Methods of Plastic Analysis.....	27
3.1 Introduction.....	27
3.2 Incremental Analysis	28
3.3 Important Definitions	34
3.4 Equilibrium Method	36
3.5 Kinematic Method Using Virtual Work.....	40
3.6 Types of Plastic Collapse	45
4. Theorems of Plastic Analysis.....	46
4.1 Criteria	46
4.2 The Upperbound (Unsafe) Theorem	47
4.3 The Lowerbound (Safe) Theorem	48
4.4 The Uniqueness Theorem.....	49
4.5 Corollaries of the Theorems	50
4.6 Application of the Theorems	51
4.7 Plastic Design	56
4.8 Summary of Important Points	59
5. Plastic Analysis of Beams	60
5.1 Example 1 – Fixed-Fixed Beam with Point Load	60
5.2 Example 2 – Propped Cantilever with Two Point Loads	63
5.3 Example 3 – Propped Cantilever under UDL	68
5.4 Continuous Beams	73

5.5	Example 4 – Continuous Beam	77
5.6	Problems	81
6.	Plastic Analysis of Frames	83
6.1	Additional Aspects for Frames	83
6.2	Example 5 –Portal Frame with Multiple Loads	86
6.3	Example 6 – Portal Frame with Crane Loads, Summer 1997	93
6.4	Example 7 – Oblique Frame, Sumer 1999	97
7.	Past Exam Questions.....	109
7.1	Sumer 2000.....	109
7.2	Summer 2001.....	110
7.3	Summer 2004.....	111
7.4	Summer 2005.....	112
7.5	Summer 2007.....	113
7.6	Semester 2 2008.....	114
7.7	Semester 2 2009.....	115
8.	References	116

1. Introduction

1.1 Background

Up to now we have concentrated on the elastic analysis of structures. In these analyses we used superposition often, knowing that for a linearly elastic structure it was valid. However, an elastic analysis does not give information about the loads that will actually collapse a structure. An indeterminate structure may sustain loads greater than the load that first causes a yield to occur at any point in the structure. In fact, a structure will stand as long as it is able to find redundancies to yield. It is only when a structure has exhausted all of its redundancies will extra load causes it to fail. Plastic analysis is the method through which the actual failure load of a structure is calculated, and as will be seen, this failure load can be significantly greater than the elastic load capacity.

To summarize this, Prof. Sean de Courcy (UCD) used to say:

“a structure only collapses when it has exhausted all means of standing”.

Before analysing complete structures, we review material and cross section behaviour beyond the elastic limit.

2. Basis of Plastic Design

2.1 Material Behaviour

A uniaxial tensile stress on a ductile material such as mild steel typically provides the following graph of stress versus strain:

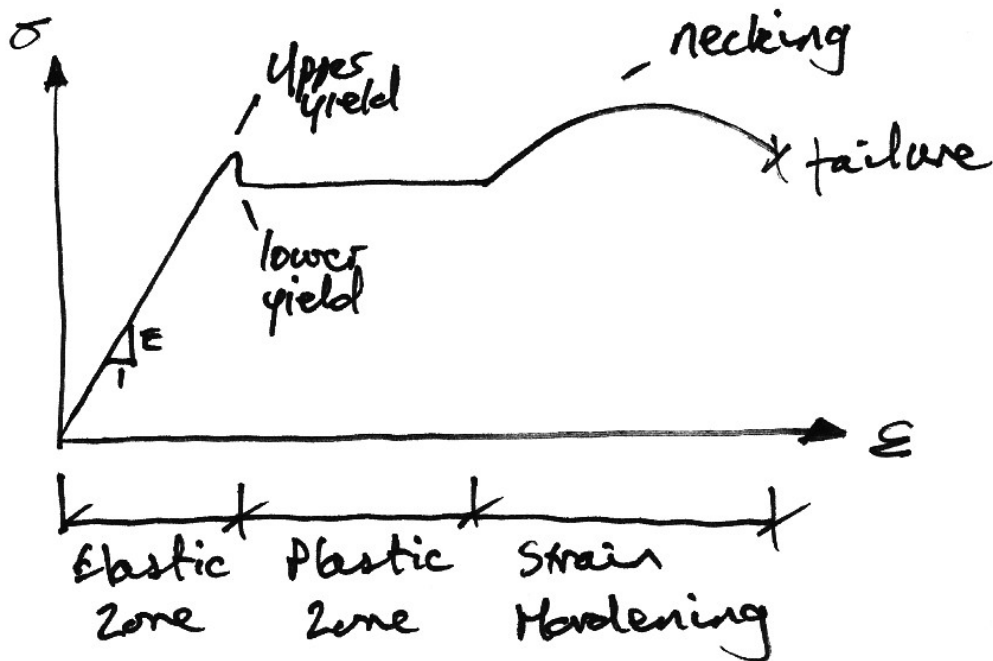

As can be seen, the material can sustain strains far in excess of the strain at which yield occurs before failure. This property of the material is called its *ductility*.

Though complex models do exist to accurately reflect the above real behaviour of the material, the most common, and simplest, model is the *idealised stress-strain curve*. This is the curve for an ideal elastic-plastic material (which doesn't exist), and the graph is:

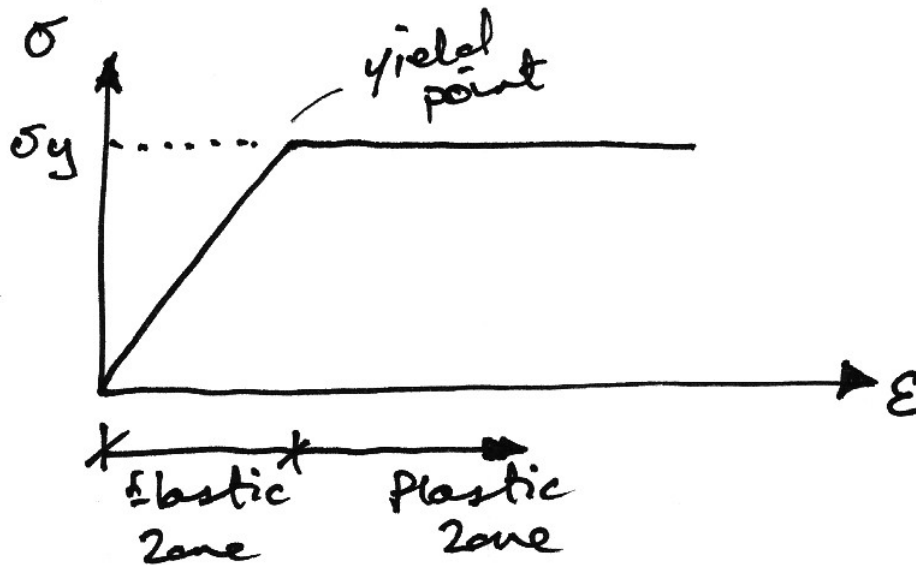

As can be seen, once the yield has been reached it is taken that an indefinite amount of strain can occur. Since so much post-yield strain is modelled, the actual material (or cross section) must also be capable of allowing such strains. That is, it must be sufficiently ductile for the idealised stress-strain curve to be valid.

Next we consider the behaviour of a cross section of an ideal elastic-plastic material subject to bending. In doing so, we seek the relationship between applied moment and the rotation (or more accurately, the curvature) of a cross section.

2.2 Cross Section Behaviour

Moment-Rotation Characteristics of General Cross Section

We consider an arbitrary cross-section with a vertical plane of symmetry, which is also the plane of loading. We consider the cross section subject to an increasing bending moment, and assess the stresses at each stage.

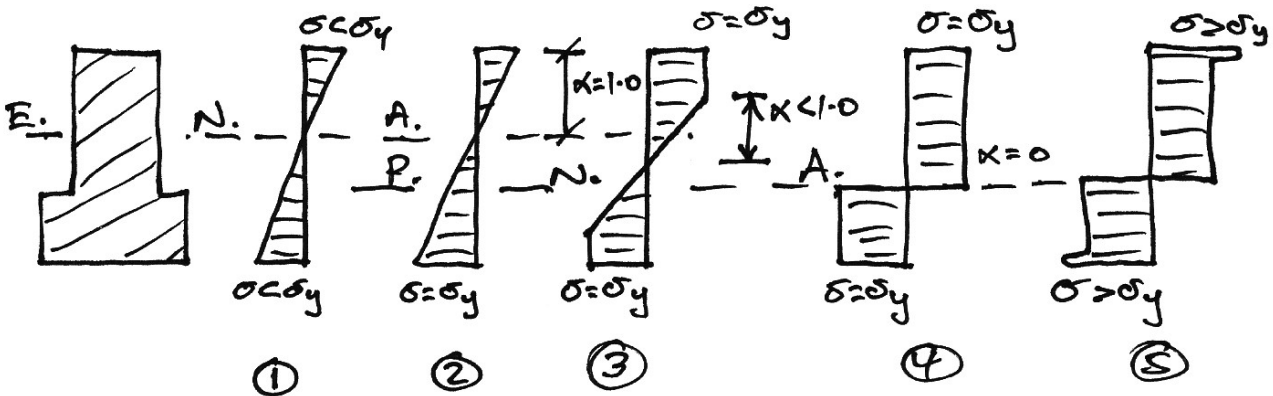

Cross-Section and Stresses

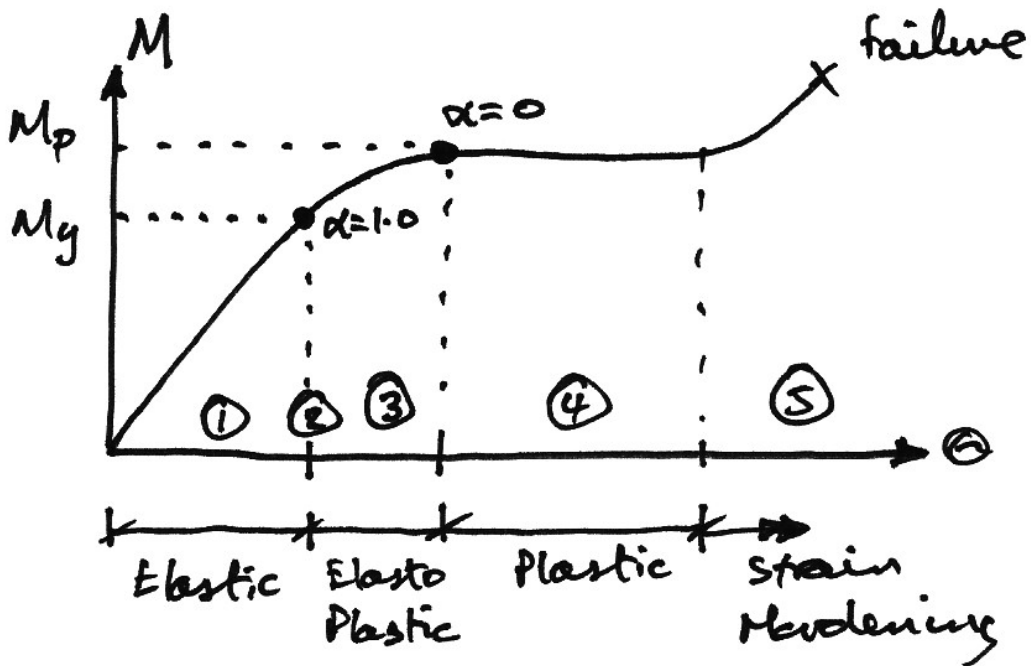

Moment-Rotation Curve

Stage 1 – Elastic Behaviour

The applied moment causes stresses over the cross-section that are all less than the yield stress of the material.

Stage 2 – Yield Moment

The applied moment is just sufficient that the yield stress of the material is reached at the outermost fibre(s) of the cross-section. All other stresses in the cross section are less than the yield stress. This is limit of applicability of an elastic analysis and of elastic design. Since all fibres are elastic, the ratio of the depth of the elastic to plastic regions, $\alpha = 1.0$.

Stage 3 – Elasto-Plastic Bending

The moment applied to the cross section has been increased beyond the yield moment. Since by the idealised stress-strain curve the material cannot sustain a stress greater than yield stress, the fibres at the yield stress have progressed inwards towards the centre of the beam. Thus over the cross section there is an elastic core and a plastic region. The ratio of the depth of the elastic core to the plastic region is $1.0 < \alpha < 0$. Since extra moment is being applied and no stress is bigger than the yield stress, extra rotation of the section occurs: the moment-rotation curve losses its linearity and curves, giving more rotation per unit moment (i.e. looses stiffness).

Stage 4 – Plastic Bending

The applied moment to the cross section is such that all fibres in the cross section are at yield stress. This is termed the Plastic Moment Capacity of the section since there are no fibres at an elastic stress, $\alpha = 0$. Also note that the full plastic moment requires an infinite strain at the neutral axis and so is physically impossible to achieve. However, it is closely approximated in practice. Any attempt at increasing the moment at this point simply results in more rotation, once the cross-section has

sufficient ductility. Therefore in steel members the cross section classification must be plastic and in concrete members the section must be under-reinforced.

Stage 5 – Strain Hardening

Due to strain hardening of the material, a small amount of extra moment can be sustained.

The above moment-rotation curve represents the behaviour of a cross section of a regular elastic-plastic material. However, it is usually further simplified as follows:

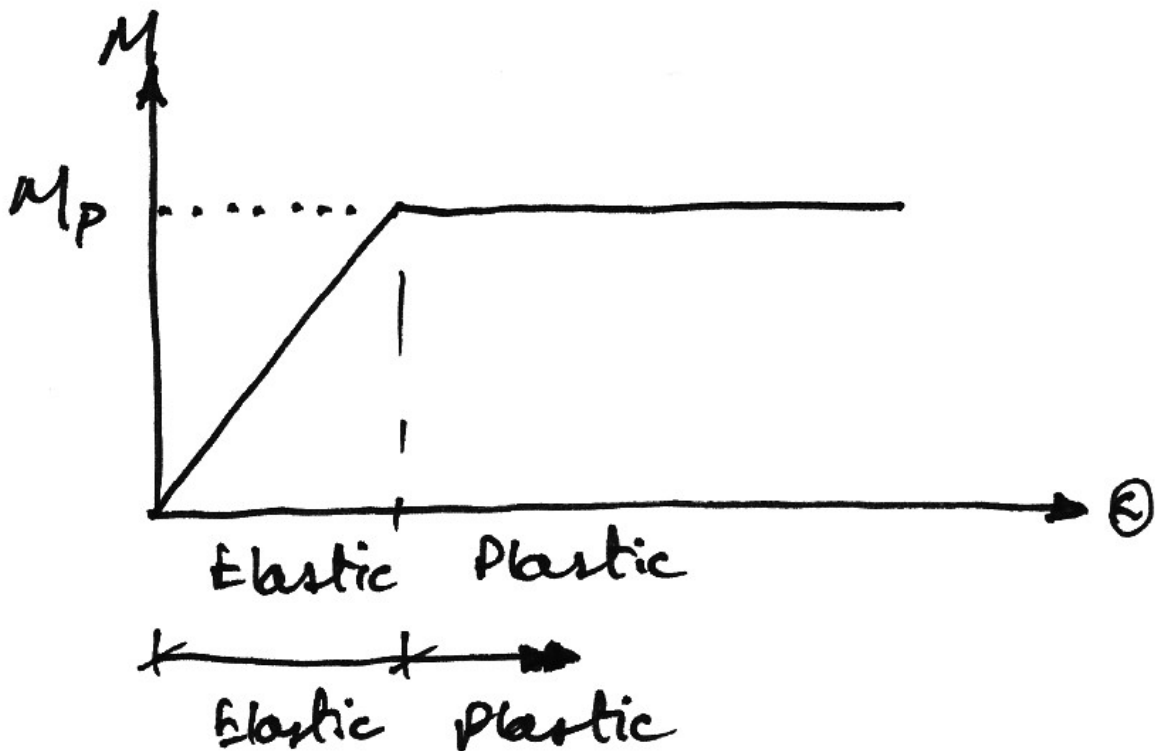

With this idealised moment-rotation curve, the cross section linearly sustains moment up to the plastic moment capacity of the section and then yields in rotation an indeterminate amount. Again, to use this idealisation, the actual section must be capable of sustaining large rotations – that is it must be ductile.

Plastic Hinge

Note that once the plastic moment capacity is reached, the section can rotate freely – that is, it behaves like a hinge, except with moment of M_p at the hinge. This is termed a *plastic hinge*, and is the basis for plastic analysis. At the plastic hinge stresses remain constant, but strains and hence rotations can increase.

Analysis of Rectangular Cross Section

Since we now know that a cross section can sustain more load than just the yield moment, we are interested in how much more. In other words we want to find the yield moment and plastic moment, and we do so for a rectangular section. Taking the stress diagrams from those of the moment-rotation curve examined previously, we have:

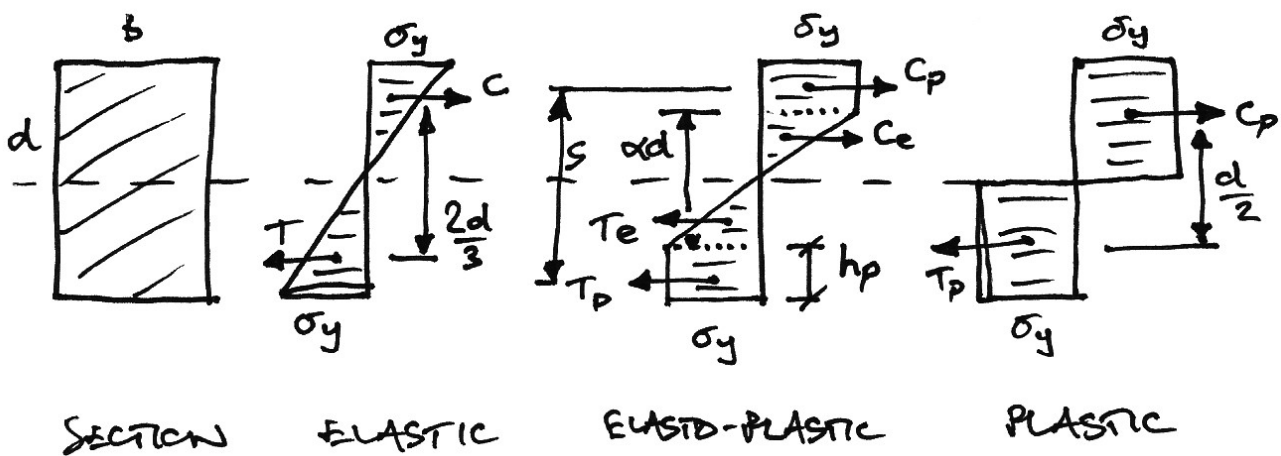

Elastic Moment

From the diagram:

$$M_y = C \times \frac{2}{3}d$$

But, the force (or the volume of the stress block) is:

$$C = T = \frac{1}{2} \sigma_y \frac{d}{2} b$$

Hence:

$$\begin{aligned}M_Y &= \left(\frac{1}{2} \sigma_Y \frac{d}{2} b \right) \left(\frac{2}{3} d \right) \\ &= \sigma_Y \cdot \frac{bd^2}{6} \\ &= \sigma_Y \cdot Z\end{aligned}$$

The term $bd^2/6$ is thus a property of the cross section called the *elastic section modulus* and it is termed Z .

Elasto-Plastic Moment

The moment in the section is made up of plastic and elastic components:

$$M_{EP} = M'_E + M'_P$$

The elastic component is the same as previous, but for the reduced depth, αd instead of the overall depth, d :

$$\begin{aligned}M'_E &= \left(\frac{1}{2} \sigma_Y \frac{\alpha d}{2} \right) \left(\frac{2\alpha d}{3} \right) \\ &= \sigma_Y \cdot \alpha^2 \cdot \frac{bd^2}{6}\end{aligned}$$

The plastic component is:

$$M'_P = C_P \cdot s$$

The lever arm, s , is:

$$s = \alpha d + h_p$$

But

$$h_p = \frac{d - \alpha d}{2} = \frac{d}{2}(1 - \alpha)$$

Thus,

$$\begin{aligned} s &= \alpha d + \frac{d}{2} - \frac{\alpha d}{2} \\ &= \frac{d}{2}(1 + \alpha) \end{aligned}$$

The force is:

$$\begin{aligned} C_p &= \sigma_Y h_p b \\ &= \sigma_Y b \frac{d}{2}(1 - \alpha) \end{aligned}$$

Hence,

$$\begin{aligned} M_p' &= \left[\sigma_Y b \frac{d}{2}(1 - \alpha) \right] \cdot \left[\frac{d}{2}(1 + \alpha) \right] \\ &= \sigma_Y \frac{bd^2}{4}(1 - \alpha^2) \end{aligned}$$

And so the total elasto-plastic moment is:

$$\begin{aligned} M_{EP} &= \sigma_Y \cdot \alpha^2 \cdot \frac{bd^2}{6} + \sigma_Y \frac{bd^2}{4}(1 - \alpha^2) \\ &= \sigma_Y \frac{bd^2}{6} \cdot \frac{(3 - \alpha^2)}{2} \end{aligned}$$

Plastic Moment

From the stress diagram:

$$M_p = C \times \frac{d}{2}$$

And the force is:

$$C = T = \sigma_y \frac{d}{2} b$$

Hence:

$$\begin{aligned} M_p &= \left(\sigma_y \frac{bd}{2} \right) \left(\frac{d}{2} \right) \\ &= \sigma_y \cdot \frac{bd^2}{4} \\ &= \sigma_y \cdot S \end{aligned}$$

The term $bd^2/4$ is a property of the cross section called the *plastic section modulus*, termed S .

Shape Factor

Thus the ratio of elastic to plastic moment capacity is:

$$\frac{M_P}{M_Y} = \frac{\sigma_Y \cdot S}{\sigma_Y \cdot Z} = \frac{S}{Z}$$

This ratio is termed the *shape factor*, f , and is a property of a cross section alone.

For a rectangular cross-section, we have:

$$f = \frac{S}{Z} = \frac{bd^2/4}{bd^2/6} = 1.5$$

And so a rectangular section can sustain 50% more moment than the yield moment, before a plastic hinge is formed. Therefore the shape factor is a good measure of the efficiency of a cross section in bending. Shape factors for some other cross sections are:



Rectangle: $f = 1.5$, as above;



Circle: $f = 1.698$;



Diamond: $f = 2.0$;



Steel I-beam: f is between 1.12 and 1.15.

Moment Rotation Curve of a Rectangular Section

It is of interest to examine the moment-rotation curve as the moment approaches the plastic moment capacity of the section. We begin by recalling the relationship between strain, ε , and distance from the neutral axis, y :

$$\varepsilon = \kappa y$$

This is a direct consequence of the assumption that plane sections remain plane and is independent of any constitutive law (e.g. linear elasticity). We next identify the yield strain (that corresponds to the yield stress, σ_y) as ε_y . The curvature that occurs at the yield moment is therefore:

$$\kappa_y = \frac{\varepsilon_y}{(d/2)} = 2 \frac{\varepsilon_y}{d}$$

For moments applied beyond the yield moment, the curvature can be found by noting that the yield strain, ε_y , occurs at a distance from the neutral axis of $\alpha d/2$, giving:

$$\kappa = \frac{\varepsilon_y}{(\alpha d/2)} = 2 \frac{\varepsilon_y}{\alpha d}$$

Thus, the ratio curvature to yield curvature is:

$$\frac{\kappa}{\kappa_y} = \frac{2\varepsilon_y/\alpha d}{2\varepsilon_y/d} = \frac{1}{\alpha}$$

From which $\alpha = \kappa_y/\kappa$.

Also, the ratio of elasto-plastic moment to yield moment is:

$$\frac{M}{M_Y} = \frac{\sigma_Y \frac{bd^2}{6} \cdot \frac{(3-\alpha^2)}{2}}{\sigma_Y \frac{bd^2}{6}} = \frac{(3-\alpha^2)}{2}$$

If we now substitute the value $\alpha = \kappa_Y/\kappa$ we find:

$$\frac{M}{M_Y} = \frac{1}{2} \left[3 - \left(\frac{\kappa_Y}{\kappa} \right)^2 \right]$$

And so finally we have:

$$\frac{M}{M_Y} = 1.5 - 0.5 \left(\frac{\kappa}{\kappa_Y} \right)^{-2}$$

Plotting this gives:

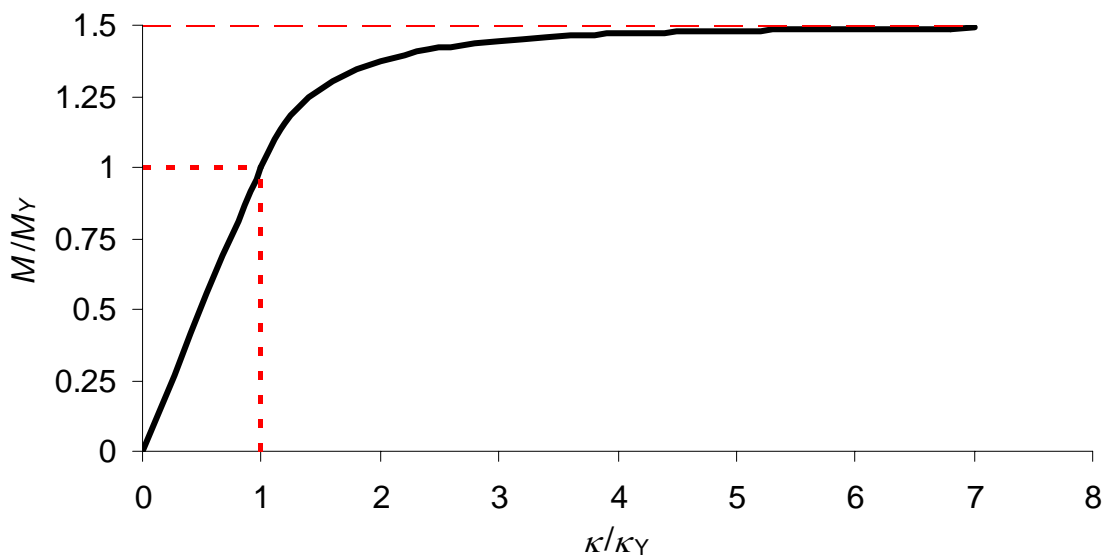

There are some important observations to be made from this graph:

- To reach the plastic moment capacity of the section requires large curvatures. Thus the section must be ductile.
- The full cross-section plasticity associated with the plastic moment capacity of a section can only be reached at infinite curvature (or infinite strain). Since this is impossible, we realise that the full plastic moment capacity is unobtainable.

To show that the idea of the plastic moment capacity of section is still useful, we examine this further. Firstly we note that strain hardening in mild steel begins to occur at a strain of about $10\varepsilon_y$. At this strain, the corresponding moment ratio is:

$$\frac{M}{M_y} = 1.5 - 0.5(10)^{-2} = 1.495$$

Since this is about 99.7% of the plastic moment capacity, we see that the plastic moment capacity of a section is a good approximation of the section's capacity.

These calculations are based on a ductility ration of 10. This is about the level of ductility a section requires to be of use in any plastic collapse analysis.

Lastly, for other cross-section shapes we have the moment-curvature relations shown in the following figure.

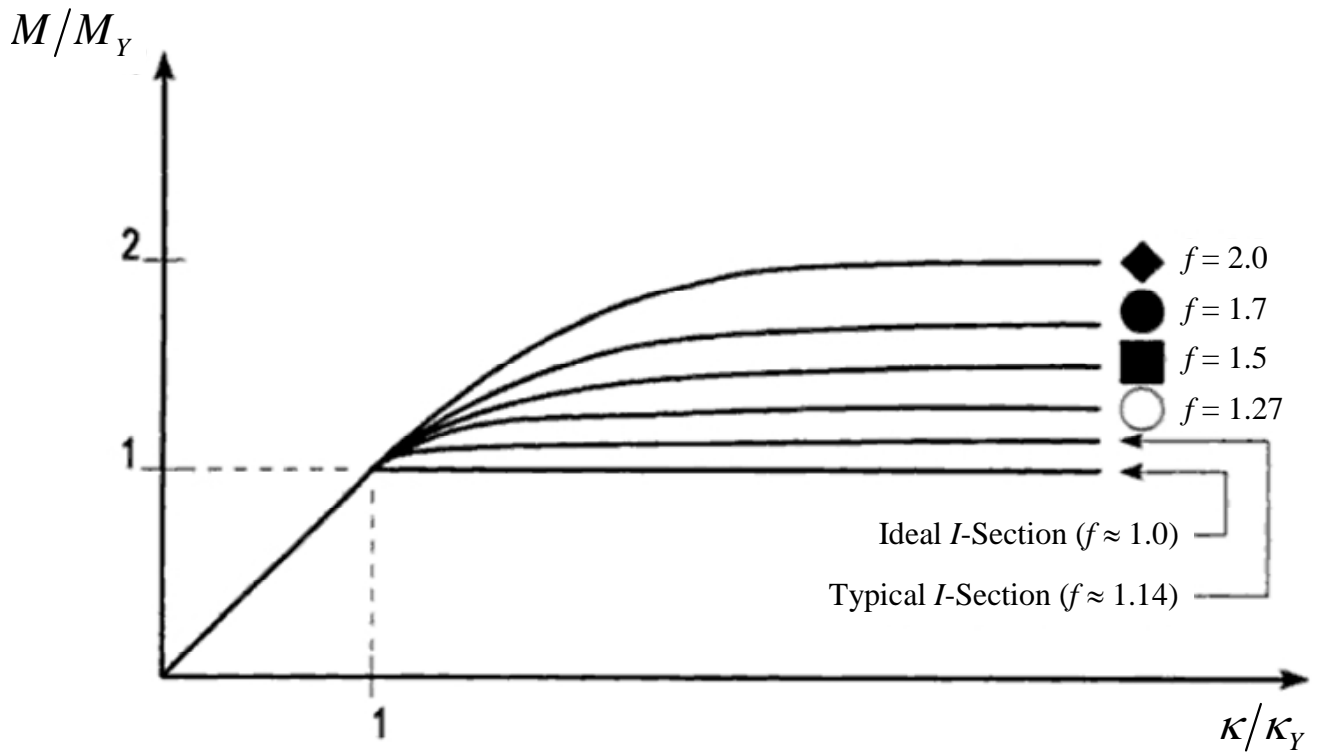

(Adapted from Bruneau et al (1998))

Effect of Axial Force on the Plastic Moment Capacity

Thus far the cross sections considered are only carrying moment. In the presence of axial force, clearly some material must be given over to carry the axial force and so is not available to carry moment, reducing the capacity of the section. Further, it should be apparent that the moment capacity of the section therefore depends on the amount of axial load being carried.

Considering a compression load as positive, more of the section will be in compression and so the neutral axis will drop. If we consider the moment and axial force separately, we have:

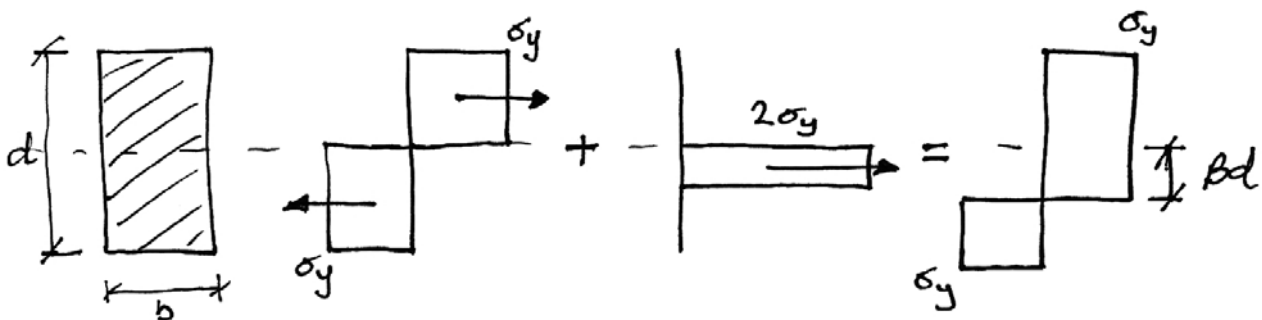

The axial force corresponding to this state is:

$$P = 2\sigma_y b(\beta d)$$

If we label the plastic ‘squash load’ of the section as:

$$P_c = \sigma_y b d$$

Then we have:

$$P = 2\beta P_C$$

Next, the collapse moment that this section offers, M_{PC} , is got by taking moments about the centroidal axis:

$$M_{PC} = M_P - P\left(\frac{1}{2}\beta d\right)$$

Using, $M_P = \sigma_Y \frac{bd^2}{4}$ and the expression for P above:

$$\begin{aligned} M_{PC} &= \left[\sigma_Y \frac{bd^2}{4} \right] - [2\sigma_Y b(\beta d)]\left(\frac{1}{2}\beta d\right) \\ &= \left(\sigma_Y \frac{bd^2}{4} \right) [1 - 4\beta^2] \end{aligned}$$

Giving,

$$M_{PC} = M_P (1 - 4\beta^2)$$

Noting that $2\beta = P/P_C$ from earlier, we now have:

$$\frac{M_{PC}}{M_P} = 1 - (2\beta)^2 = 1 - \left(\frac{P}{P_C}\right)^2$$

Thus the interaction equation is:

$$\left(\frac{M_{PC}}{M_P}\right) + \left(\frac{P}{P_C}\right)^2 = 1$$

Plotting this shows the yield surface (which can be shown is always convex):

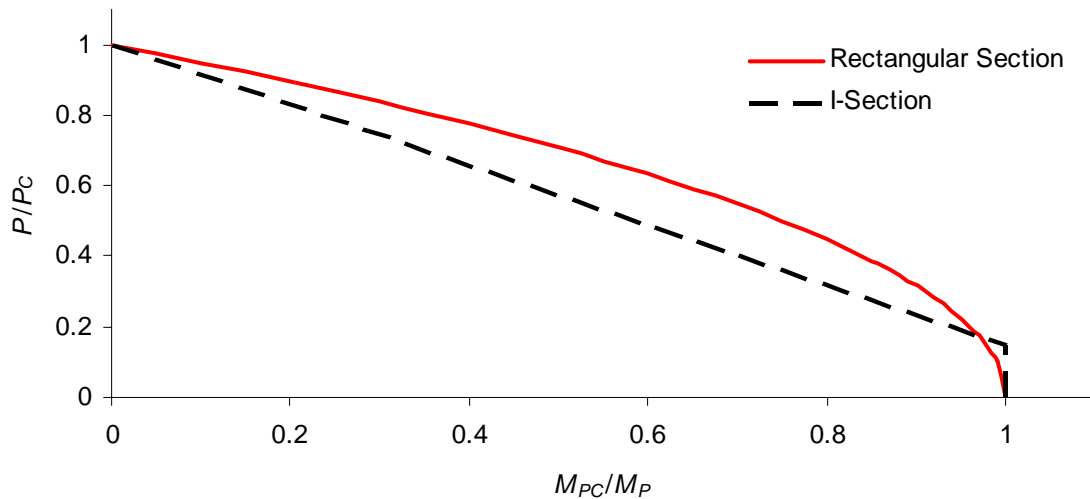

Also shown in this plot is an approximate interaction line for I-sections, given by:

$$\frac{P}{P_C} > 0.15: \quad \frac{M_{PC}}{M_P} = 1.18 \left(1 - \frac{P}{P_C}\right)$$

$$\frac{P}{P_C} \leq 0.15: \quad \frac{M_{PC}}{M_P} = 1.0$$

This says that for I-sections with an axial load of less than 15% of the squash load, the full plastic moment capacity may be still considered. This is because the web carries the axial load whilst contributing little to the moment capacity of the section.

Shear force can also reduce the plastic moment capacity of a section in some cases. In the presence of axial and shear, a three dimensional failure surface is required.

2.3 Plastic Hinge Formation

Simply-Supported Beam

We investigate the collapse of a simply supported beam under central point load with the information we now have.

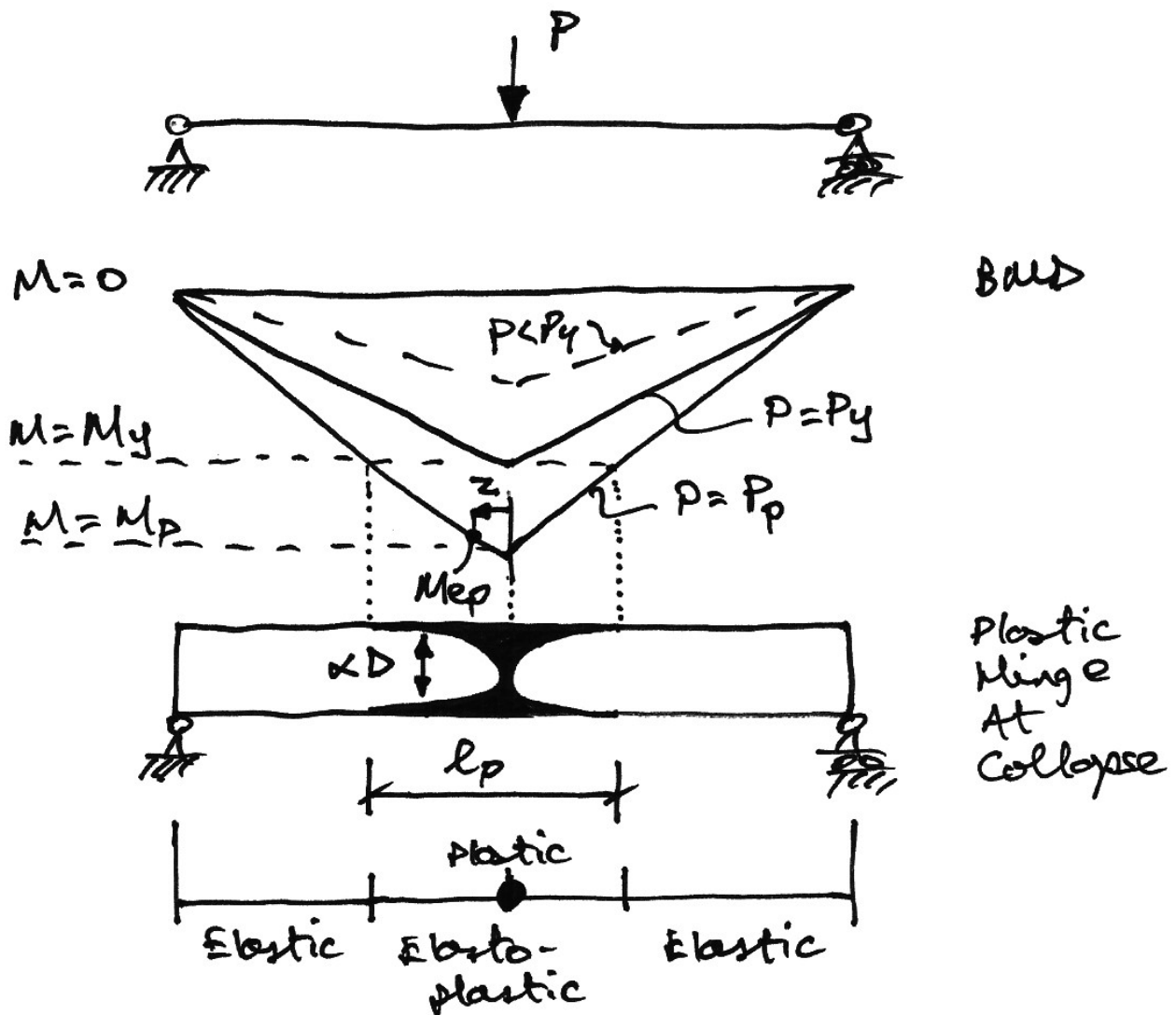

The bending moment at the centre of the beam is given by:

$$M_c = \frac{PL}{4}$$

Therefore the load at which yield first occurs is:

$$M_C = M_Y = \frac{P_Y L}{4}$$
$$\therefore P_Y = \frac{4M_Y}{L}$$

Collapse of this beam occurs when the plastic hinge forms at the centre of the beam, since the extra hinge turns the statically determinate beam into a mechanism. The collapse load occurs when the moment at the centre reaches the plastic moment capacity:

$$M_C = M_P = \frac{P_P L}{4}$$
$$\therefore P_P = \frac{4M_P}{L}$$

The ratio collapse to yield load is:

$$\frac{P_P}{P_Y} = \frac{4M_P/L}{4M_Y/L} = \frac{M_P}{M_Y}$$

But since,

$$\frac{M_P}{M_Y} = \frac{S}{Z} = f$$

The ratio is just the shape factor of the section. This is a general result: *the ratio of collapse load to first yield load is the shape factor of the member, for statically determinate prismatic structures.*

Shape of the Plastic Hinge

We are also interested in the plastic hinge, and the zone of elasto-plastic bending. As can be seen from the diagram, the plastic material zones extend from the centre out to the point where the moment equals the yield moment.

Using similar triangles from the bending moment diagram at collapse, we see that:

$$\frac{M_p}{L} = \frac{M_p - M_y}{l_p} = \frac{M_p - M_{EP}}{2z}$$

In which M_{EP} is the elasto-plastic moment at a distance z from the plastic hinge, and where $z \leq \frac{l_p}{2}$, where l_p is the total length of the plastic region.

Equating the first two equations gives:

$$l_p = \frac{L}{M_p} (M_p - M_y) = L \left(1 - \frac{M_y}{M_p} \right) = L \left(1 - \frac{1}{f} \right)$$

And so for a beam with a rectangular cross section ($f = 1.5$) the plastic hinge extends for a length:

$$l_p = L \left(1 - \frac{1}{1.5} \right) = \frac{L}{3}$$

Lastly, the shape of the hinge follows from the first and third equation:

$$\frac{M_P}{L} = \frac{M_P - M_{EP}}{2z}$$

$$\frac{z}{L} = \frac{1}{2M_P}(M_P - M_{EP})$$

$$\frac{z}{L} = \frac{1}{2}\left(1 - \frac{M_{EP}}{M_P}\right)$$

From our expressions for the elasto-plastic and plastic moments, we have:

$$\frac{z}{L} = \frac{1}{2}\left(1 - \frac{\sigma_y (bd^2/6)(1/2)(3 - \alpha^2)}{\sigma_y (bd^2/4)}\right)$$

$$= \frac{1}{2}\left(1 - \frac{2}{3} \cdot \frac{1}{2} \cdot (3 - \alpha^2)\right)$$

$$\frac{z}{L} = \frac{\alpha^2}{6}$$

This shows that the plastic region has a parabolic profile, and confirms that the total length of the hinge, $l_p = 2z$, is $L/3$ at the location where $\alpha = 1.0$.

Using a similar form of analysis, we can show that under a UDL the plastic hinge has a linear profile given by $z/L = 2\alpha\sqrt{3}$ and that its length is $L/\sqrt{3}$.

3. Methods of Plastic Analysis

3.1 Introduction

There are three main approaches for performing a plastic analysis:

The Incremental Method

This is probably the most obvious approach: the loads on the structure are incremented until the first plastic hinge forms. This continues until sufficient hinges have formed to collapse the structure. This is a labour-intensive, 'brute-force', approach, but one that is most readily suited for computer implementation.

The Equilibrium (or Statical) Method

In this method, free and reactant bending moment diagrams are drawn. These diagrams are overlaid to identify the likely locations of plastic hinges. This method therefore satisfies the equilibrium criterion first leaving the two remaining criterion to be derived therefrom.

The Kinematic (or Mechanism) Method

In this method, a collapse mechanism is first postulated. Virtual work equations are then written for this collapse state, allowing the calculations of the collapse bending moment diagram. This method satisfies the mechanism condition first, leaving the remaining two criteria to be derived therefrom.

We will concentrate mainly on the Kinematic Method, but introduce now the Incremental Method to illustrate the main concepts.

3.2 Incremental Analysis

Illustrative Example – Propped Cantilever

We now assess the behaviour of a simple statically indeterminate structure under increasing load. We consider a propped cantilever with mid-span point load:

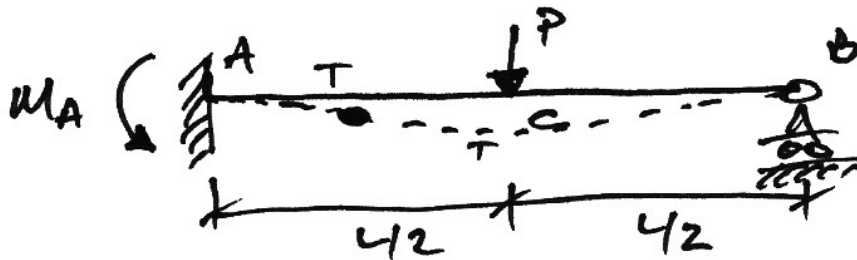

From previous analyses we know that:

$$M_A = \frac{3PL}{16} \qquad M_C = \frac{5PL}{32}$$

We will take the span to be $L=1$ m and the cross section to have the following capacities:

$$M_y = 7.5 \text{ kNm} \qquad M_p = 9.0 \text{ kNm}$$

Further, we want this beam to be safe at a working load of 32 kN, so we start there.

Load of 32 kN

At this value of load the BMD is as shown, with:

$$M_A = \frac{3(32)(1)}{16} = 6 \text{ kNm} \qquad M_C = \frac{5(32)(1)}{32} = 5 \text{ kNm}$$

Since the peak moments are less than the yield moments, we know that yield stress has not been reached at any point in the beam. Also, the maximum moment occurs at A and so this point will first reach the yield moment.

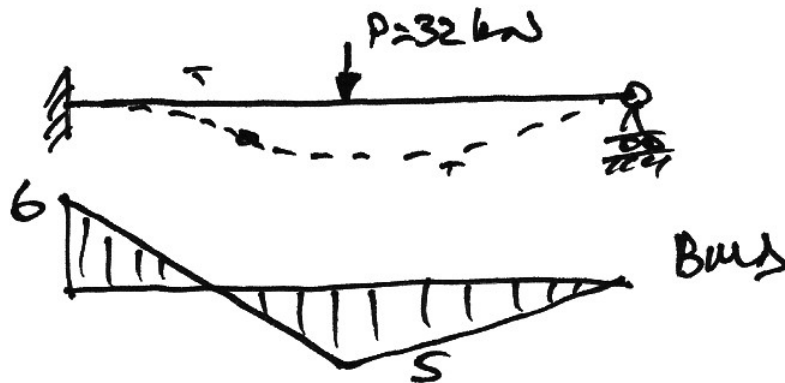

Load of 40 kN

At this load the BDM becomes that as shown. The moment at A has now reached the yield moment and so the outer fibres at A are at yield stress.

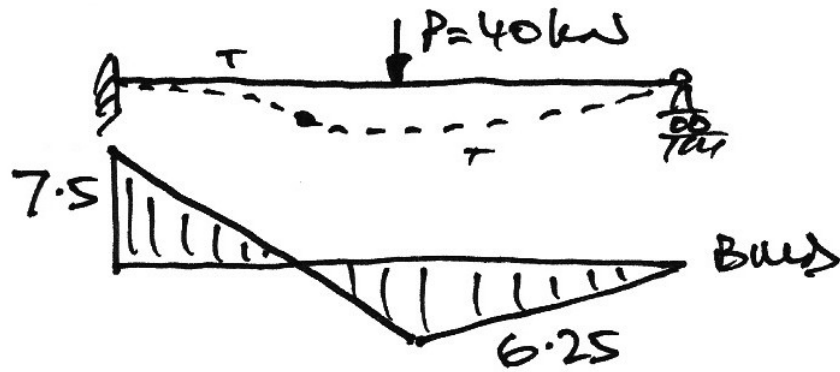

Load of 48 kN

The BMD is as shown. The moment at A is now 9 kNm – the plastic moment capacity of the section – and so the cross section at A has fully yielded. Thus a plastic hinge has formed at A and so no extra moment can be taken at A , but A can rotate freely with constant moment of 9 kNm . Also, the moment at C has reached the yield moment. Note that the structure does not collapse since there are not sufficient hinges for it to be a mechanism yet: it now acts like a simply-supported beam with a pin at A (the plastic hinge) and B (the pin support).

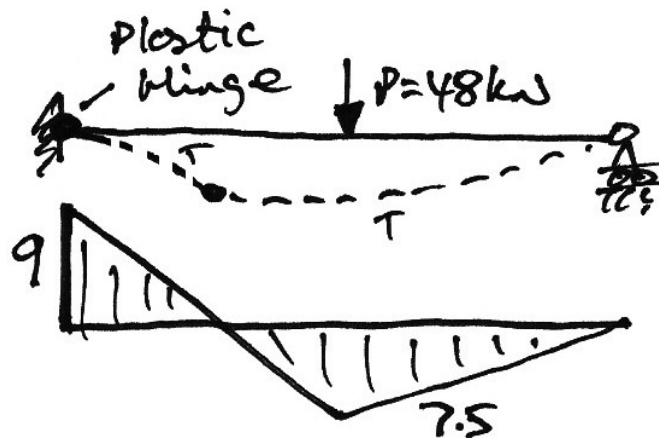

Load of 54 kN

Since the moment at A has already reached the plastic moment of the section, no extra moment can be taken there and M_A must remain 9 kNm whilst allowing rotation to freely occur. Therefore, all of the extra moment caused by the increase in load of $54 - 48 = 6$ kN must be taken by the structure as if it were a simply-supported beam. That is, a beam free to rotate at both ends. The extra moment at C is thus $PL/4 = 6 \cdot 1/4 = 1.5$ kNm bring the total moment at C to 9 kNm – the plastic moment capacity of the section. Therefore a plastic hinge forms at C and the structure is not capable of sustaining anymore load – becomes a mechanism – and so collapse ensues.

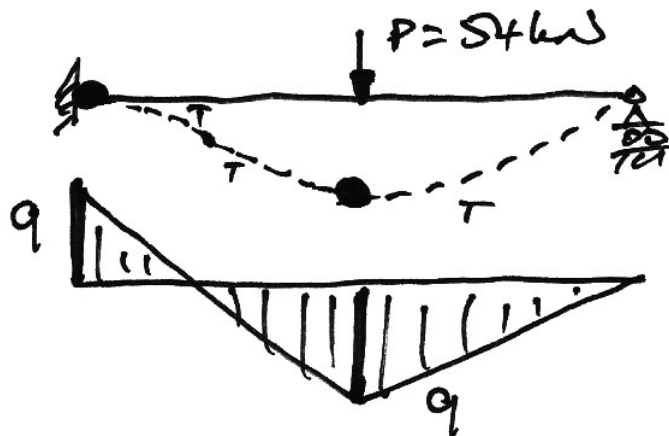

Discussion

There are several things to note from this analysis:

1. The actual load carried by the beam is 54 kN, greater than the load at which yield first occurs, 40 kN, the elastic limit. This difference of 35% represents the extra capacity of the structure over the elastic capacity, so to ignore it would be very inefficient.
2. At the end of the analysis $M_A = M_C = 9$ kNm and so $M_A/M_C = 1$. Since for an elastic analysis $M_A/M_C = (3PL/16)/(5PL/32) = 1.2$, it is evident that our analysis is not an elastic analysis and so is a plastic analysis.
3. The height of the free bending moment diagram was $PL/4$ throughout, as required by equilibrium – only the height of the reactant bending moment diagram varied. This is the basis of the Equilibrium Method.
4. At the point of collapse we had 4 reactions and 2 plastic hinges giving a statical indeterminacy of $R - C - 3 = 4 - 2 - 3 = -1$ which is a mechanism and so collapse occurs.
5. The load can only increase from 48 kN to 54 kN once the cross section at A has sufficient ductility to allow it rotate thereby allowing the extra load to be taken at C . If there was not sufficient ductility there may have a brittle-type catastrophic failure at A resulting in the beam failing by rotating about B before the full plastic capacity of the structure is realized. Therefore it is only by having sufficient ductility that a plastic analysis can be used.

Some of these points are general for any plastic analysis and these generalities are known as the *Theorems of Plastic Analysis*. However, before looking at these theorems we need a simpler way of analysing for the collapse of structures: the Incremental Method just used clearly works, but is very laborious.

3.3 Important Definitions

Load Factor

The load factor for a possible collapse mechanism i , denoted λ_i , is of prime importance in plastic analysis:

$$\lambda_i = \frac{\text{Collapse Load for Mechanism } i}{\text{Working Load}}$$

The working load is the load which the structure is expected to carry in the course of its lifetime.

The collapse load factor, λ_c , is the load factor at which the structure will actually fail. It is therefore the minimum of the load factors for the n_m different possible collapse mechanisms:

$$\lambda_c = \min_{1 \leq i \leq n_m} \lambda_i$$

In our previous analysis the working load was 32 kN and the collapse load for the single mechanism was found to be 54 kN. Hence:

$$\lambda_c = \frac{54}{32} = 1.6875$$

Factor of Safety

This is defined as:

$$\text{FoS} = \frac{\text{First yield load}}{\text{Working Load}}$$

The FoS is an elastic analysis measure of the safety of a design. For our example:

$$\text{FoS} = \frac{40}{32} = 1.25$$

Prior to the limit-state approach, codes of practice were based on this definition of safety.

3.4 Equilibrium Method

Introduction

To perform this analysis we generally follow the following steps:

1. Find a primary structure by removing redundants until the structure is statically determinate;
2. Draw the primary(or free) bending moment diagram;
3. Draw the reactant BMD for each redundant, as applied to the primary structure;
4. Construct a composite BMD by combining the primary and reactant BMDs;
5. Determine the equilibrium equations from the composite BMD;
6. Choose the points where plastic hinges are likely to form and introduce into the equilibrium equations;
7. Calculate the collapse load factor, or plastic moment capacity as required.

For different possible collapse mechanisms, repeat steps 6 and 7, varying the hinge locations.

We now apply this method to the Illustrative Example previously analyzed.

Illustrative Example – Continued

Steps 1 to 3 of the Equilibrium Method are illustrated in the following diagram:

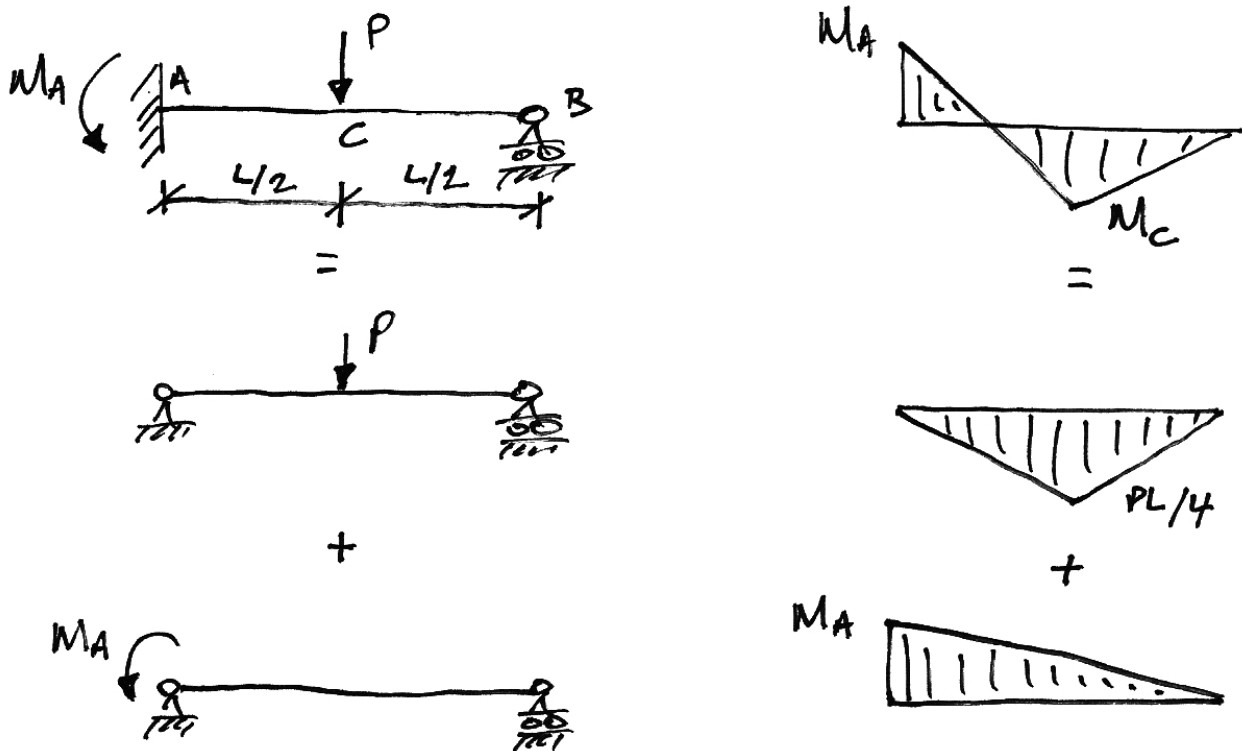

For Step 4, in constructing the Composite BMD, we arbitrarily choose tension on the underside of the beam as positive. By convention in the Equilibrium Method, instead of drawing the two BMDs on opposite sides (as is actually the case), the reactant BMD is drawn ‘flipped’ over the line and subtracted from the primary BMD: the net remaining area is the final BMD. This is best explained by illustration below:



As may be seen from the composite diagram, M_A , can actually have any value (for example, if a rotational spring support existed at A), once overall equilibrium of the structure is maintained through the primary (or free) BMD ordinate of $PL/4$.

For Step 5, from the diagram, the equilibrium equation is:

$$M_C = \frac{PL}{4} - \frac{M_A}{2}$$

For Step 6, we recognize that there are two hinges required to collapse the structure and identify the peak moments from the diagram as being at A and C. Thus these are the likely hinge locations. Setting $M_A = M_C = M_P$ in the equilibrium equation gives:

$$M_P = \frac{PL}{4} - \frac{M_P}{2}$$

This is equivalent to drawing the following diagram:

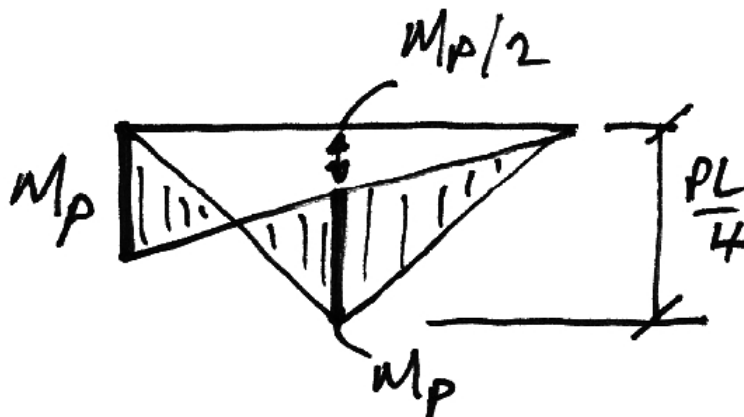

For Step 7, we solve this equation for the collapse load:

$$\frac{3}{2}M_p = \frac{PL}{4}$$
$$P = \frac{6M_p}{L}$$

For our particular example, $L = 1$ m, $M_p = 9$ kNm, and $P = 32\lambda$. Thus:

$$32\lambda = \frac{6(9)}{1}$$

And so the collapse load factor is:

$$\lambda_c = 1.6875$$

Which is the same as the results previously found.

3.5 Kinematic Method Using Virtual Work

Introduction

Probably the easiest way to carry out a plastic analysis is through the Kinematic Method using virtual work. To do this we allow the presumed shape at collapse to be the compatible displacement set, and the external loading and internal bending moments to be the equilibrium set. We can then equate external and internal virtual work, and solve for the collapse load factor for that supposed mechanism.

Remember:

- Equilibrium set: the internal bending moments at collapse;
- Compatible set: the virtual collapsed configuration (see below).

Note that in the actual collapse configuration the members will have elastic deformation in between the plastic hinges. However, since a virtual displacement does not have to be real, only compatible, we will choose to ignore the elastic deformations between plastic hinges, and take the members to be straight between them.

Illustrative Example – Continued

Actual Collapse Mechanism

So for our previous beam, we know that we require two hinges for collapse (one more than its degree of redundancy), and we think that the hinges will occur under the points of peak moment, A and C. Therefore impose a unit virtual displacement at C and relate the corresponding virtual rotations of the hinges using $S = R\theta$, giving:

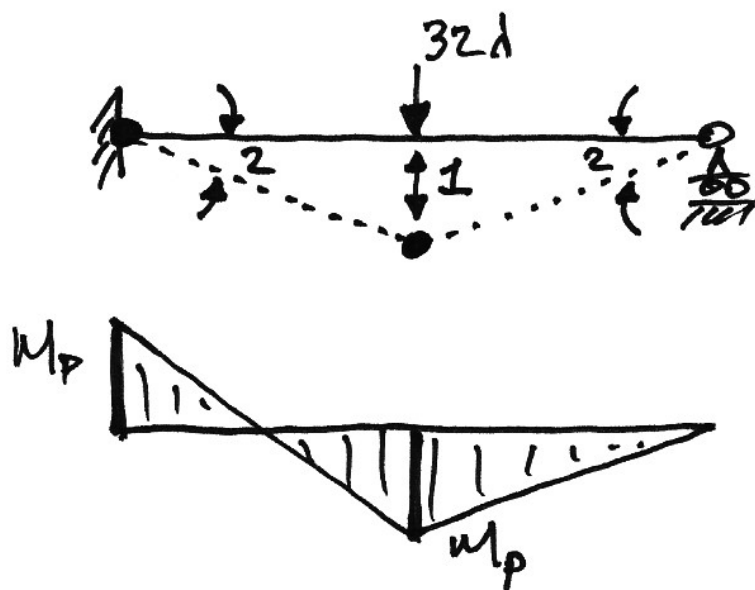

Notice that the collapse load is the working load times the collapse load factor. So:

$$\begin{aligned} \delta W_e &= \delta W_i \\ (32\lambda)(1) &= \underbrace{(M_p)(2)}_{\text{At A}} + \underbrace{(M_p)(4)}_{\text{At C}} \\ 32\lambda &= 6M_p \\ \lambda &= \frac{6(9)}{32} = 1.6875 \end{aligned}$$

since $M_p = 9$ kNm. This result is as found before.

Other Collapse Mechanisms

For the collapse mechanism looked at previously, it seemed obvious that the plastic hinge in the span should be beneath the load. But why? Using virtual work we can examine any possible collapse mechanism. So let's consider the following collapse mechanism and see why the plastic hinge has to be located beneath the load.

Plastic Hinge between A and C:

Imposing a unit virtual deflection at B, we get the following collapse mechanism:

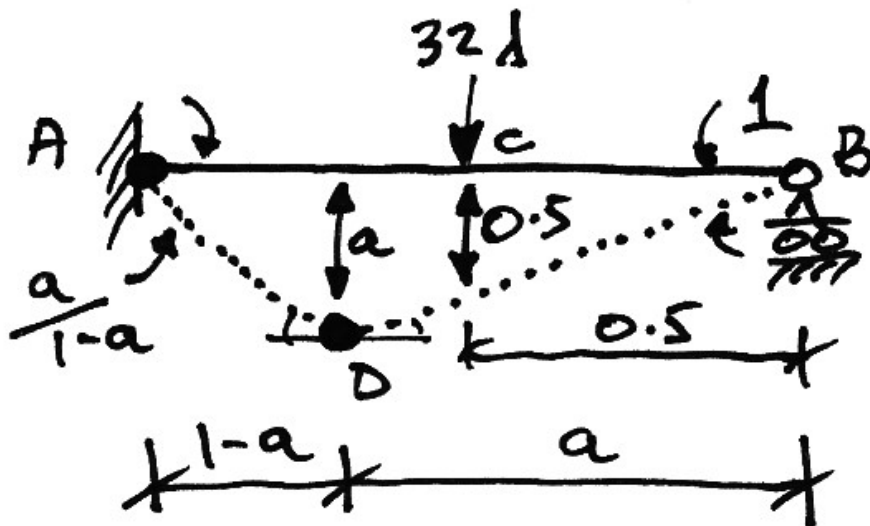

And so the virtual work equation becomes:

$$\delta W_e = \delta W_i$$

$$(32\lambda)(0.5) = \underbrace{(M_p)\left(\frac{a}{1-a}\right)}_{\text{At A}} + \underbrace{(M_p)\left(\frac{a}{1-a} + 1\right)}_{\text{At D}}$$

$$16\lambda = M_p \left[\frac{2a + (1-a)}{1-a} \right]$$

And since $M_p = 9$ kNm:

$$\lambda_{1 < a \leq 0.5} = \frac{9}{16} \left[\frac{a+1}{1-a} \right] \quad \text{Eq. (1)}$$

And so we see that the collapse load factor for this mechanism depends on the position of the plastic hinge in the span.

Plastic Hinge between C and B:

Again imposing a unit virtual deflection at B we get:

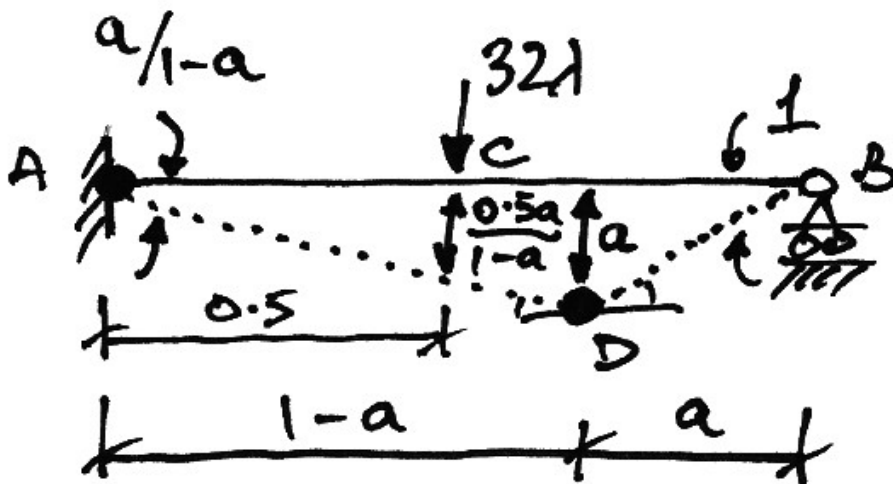

And so the virtual work equation becomes:

$$\begin{aligned} \delta W_e &= \delta W_i \\ (32\lambda) \left(\frac{0.5a}{1-a} \right) &= \underbrace{(M_p) \left(\frac{a}{1-a} \right)}_{\text{At A}} + \underbrace{(M_p) \left(\frac{a}{1-a} + 1 \right)}_{\text{At D}} \\ 16\lambda \left(\frac{a}{1-a} \right) &= M_p \left[\frac{2a + (1-a)}{1-a} \right] \\ 16\lambda a &= M_p (1+a) \end{aligned}$$

Using $M_p = 9$ kNm:

$$\lambda_{0.5 < a \leq 0} = \frac{9}{16} \left[\frac{1+a}{a} \right] \quad \text{Eq. (2)}$$

And again we see that the load factor depends on the position of the hinge.

Summary

Plotting how the collapse load factor changes with the position of the hinge, we get:

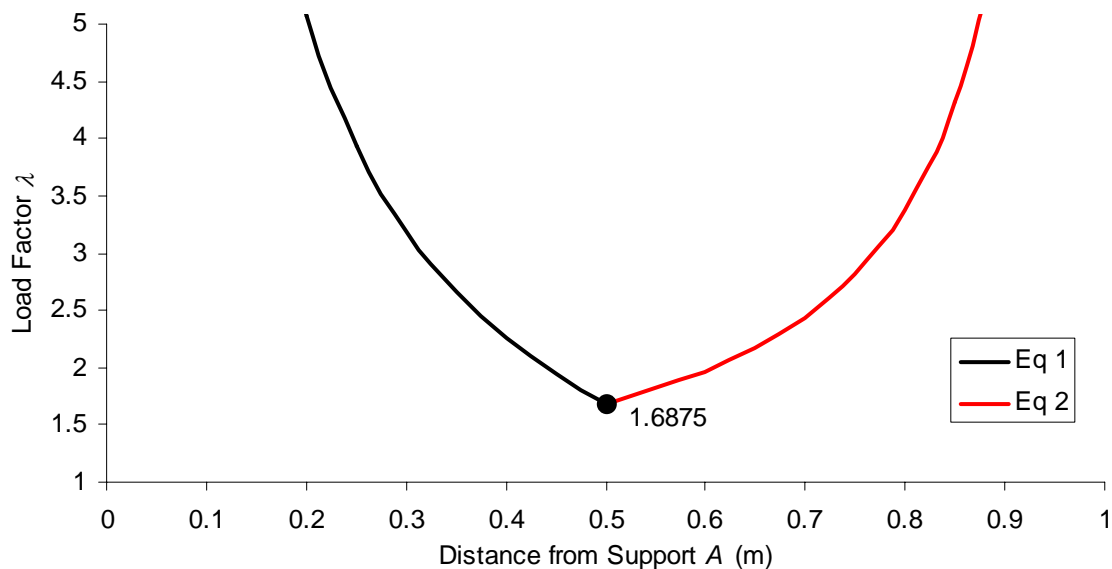

This tells us that when the load reaches 1.6875 times the working load (i.e. 54 kN) a hinge will form underneath the load, at point C, 0.5 m from support A. It also tells us that it would take more than 54 kN for a hinge to form at any other place, *assuming it hadn't already formed at C*. Thus the actual collapse load factor is the smallest of all the possible load factors. Hence we can see that in analysing proposed collapse mechanisms, we are either correct ($\lambda_c = 1.6875$) or we are unsafe ($\lambda > \lambda_c$). This is why plastic analysis is an *upperbound* method.

3.6 Types of Plastic Collapse

Complete Collapse

In the cases considered so far, collapse occurred when a hinge occurred for each of the number of redundants, r , (making it a determinate structure) with an extra hinge for collapse. Thus the number of hinges formed, $h = r + 1$ (the degree of indeterminacy plus one).

Partial Collapse

This occurs when $h < r + 1$, but a collapse mechanism, of a localised section of the structure can form. A common example is a single span of a continuous beam.

Over-Complete Collapse

For some frames, two (or more) possible collapse mechanisms are found ($h = r + 1$) with the actual collapse load factor. Therefore they can be combined to form another collapse mechanism with the same collapse load factor, but with an increased number of hinges, $h > r + 1$.

4. Theorems of Plastic Analysis

4.1 Criteria

In Plastic Analysis to identify the correct load factor, there are three criteria of importance:

1. **Equilibrium:** the internal bending moments must be in equilibrium with the external loading.
2. **Mechanism:** at collapse the structure, or a part of, can deform as a mechanism.
3. **Yield:** no point in the structure can have a moment greater than the plastic moment capacity of the section it is applied to.

Based on these criteria, we have the following theorems.

4.2 The Upperbound (Unsafe) Theorem

This can be stated as:

If a bending moment diagram is found which satisfies the conditions of equilibrium and mechanism (but not necessarily yield), then the corresponding load factor is either greater than or equal to the true load factor at collapse.

This is called the unsafe theorem because for an arbitrarily assumed mechanism the load factor is either exactly right (when the yield criterion is met) or is wrong and is too large, *leading a designer to think that the frame can carry more load than is actually possible.*

Think of it like this: **unless it's exactly right, it's dangerous.**

Since a plastic analysis will generally meet the equilibrium and mechanism criteria, by this theorem a plastic analysis is either right or dangerous. This is why plastic analyses are not used as often in practice as one might suppose.

The above theorem can be easily seen to apply to the *Illustrative Example*. When we varied the position of the hinge we found a collapse load factor that was either correct ($\lambda = \lambda_c = 1.6875$) or was too big ($\lambda > \lambda_c$).

4.3 The Lowerbound (Safe) Theorem

This can be stated as:

If a bending moment diagram is found which satisfies the conditions of equilibrium and yield (but not necessarily that of mechanism), then the corresponding load factor is either less than or equal to the true load factor at collapse.

This is a safe theorem because the load factor will be less than (or at best equal to) the collapse load factor once equilibrium and yield criteria are met leading the designer to think that the structure can carry less than or equal to its actual capacity.

Think of it like this: **it's either wrong and safe or right and safe.**

Since an elastic analysis will always meet equilibrium and yield conditions, an elastic analysis will always be safe. This is the main reason that it is elastic analysis that is used, in spite of the significant extra capacity that plastic analysis offers.

4.4 The Uniqueness Theorem

Linking the upper- and lower-bound theorems, we have:

If a bending moment distribution can be found which satisfies the three conditions of equilibrium, mechanism, and yield, then the corresponding load factor is the true load factor at collapse.

So to have identified the correct load factor (and hence collapse mechanism) for a structure we need to meet all three of the criteria:

1. Equilibrium;
2. Mechanism;
3. Yield.

The permutations of the three criteria and the three theorems are summarized in the following table:

<i>Criterion</i>	<i>Upperbound (Unsafe) Theorem</i>	<i>Lowerbound (Safe) Theorem</i>	<i>Unique Theorem</i>
Mechanism	} $\lambda \geq \lambda_c$	} $\lambda \leq \lambda_c$	} $\lambda = \lambda_c$
Equilibrium			
Yield			

The Uniqueness Theorem does not claim that any particular collapse mechanism is unique – only that the collapse load factor is unique. Although rare, it is possible for more than one collapse mechanism to satisfy the Uniqueness Theorem, but they will have the same load factor.

4.5 Corollaries of the Theorems

Some other results immediately apparent from the theorems are the following:

1. If the collapse loads are determined for all possible mechanisms, then the actual collapse load will be the lowest of these (Upperbound Theorem);
2. The collapse load of a structure cannot be decreased by increasing the strength of any part of it (Lowerbound Theorem);
3. The collapse load of a structure cannot be increased by decreasing the strength of any part of it (Upperbound Theorem);
4. The collapse load is independent of initial stresses and the order in which the plastic hinges form (Uniqueness Theorem);

The first point above is the basis for using virtual work in plastic analysis. However, in doing so, it is essential that the designer considers the actual collapse more. To not do so would lead to an unsafe design by the Upperbound Theorem.

4.6 Application of the Theorems

Illustrative Example – Continued

Plastic Hinge Under the Load

We discovered previously that the collapse load factor was 1.6875 and this occurred when the hinge was under the point load. Therefore, this collapse mechanism should meet all three criteria of the Uniqueness Theorem:

1. Equilibrium: check on the moment at C say:

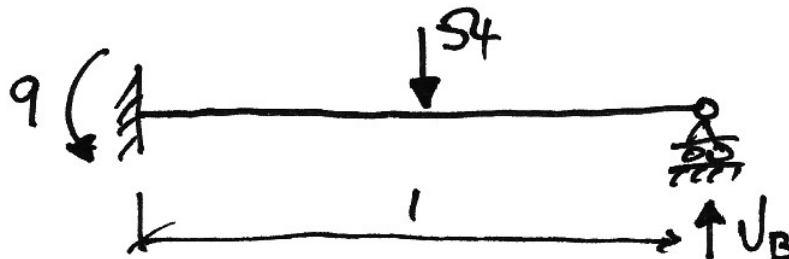

$$\sum M \text{ about } A = 0 \quad 54 \cdot 0.5 - 9 - V_B = 0 \Rightarrow V_B = 18 \text{ kN}$$

Thus, from a free-body diagram of $|CB|$, $M_c = 18 \cdot 0.5 = 9 \text{ kNm}$ as expected. Thus the equilibrium condition is met.

2. Mechanism: Given the number of hinges it is obvious the structure collapses:



$$R - C - 3 = 4 - 2 - 3 = -1$$

3. Yield: Check that there is no moment greater than $M_p = 9$ kNm:

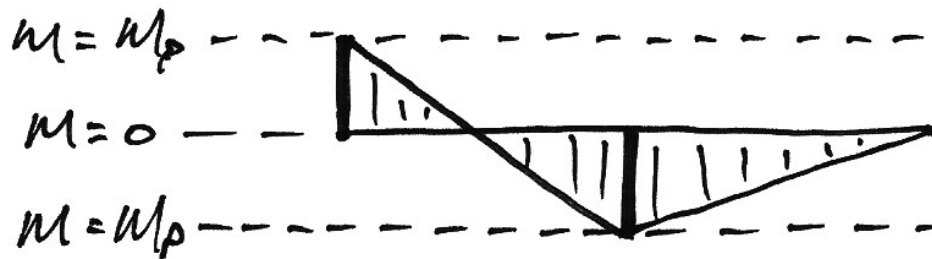

And so the yield criterion is met.

Since all three conditions are met we are assured that we have the actual collapse load factor by the Uniqueness Theorem.

Other Collapse Modes

Using the analyses carried out previously for different positions of the plastic hinge, we can check these collapse modes against the Uniqueness Theorem. For the case of the hinge between A and C:

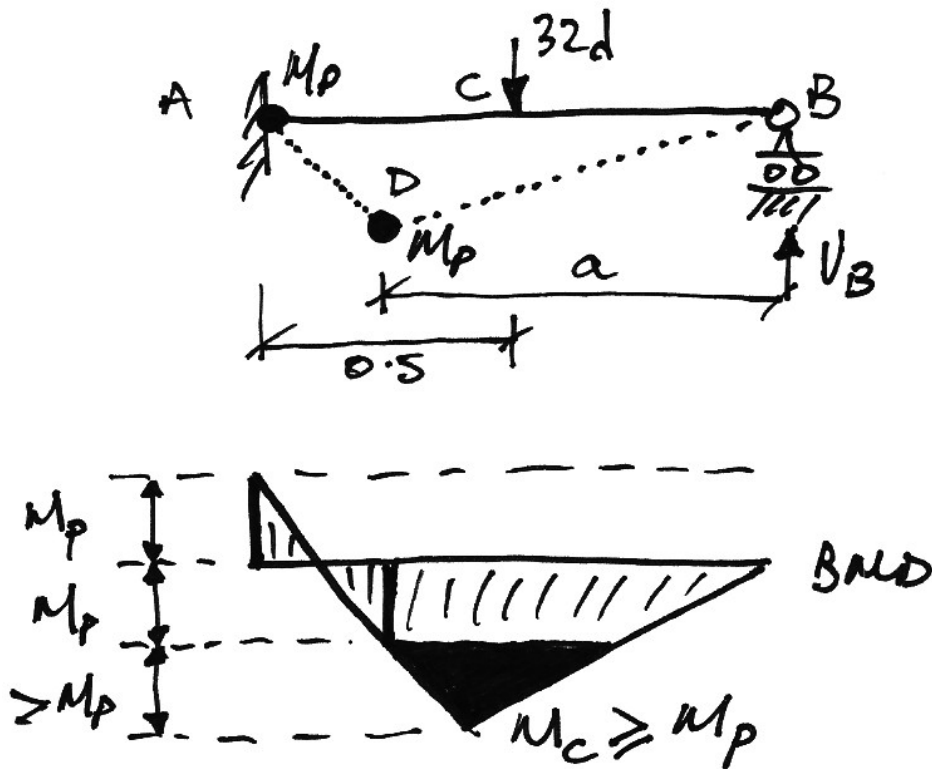

To determine this BMD, we calculate the reaction V_B by considering the free body diagram BCD :

$$\sum M \text{ about } D = 0 \quad \therefore M_p + 32\lambda(a - 0.5) - V_B a = 0$$

$$\therefore V_B = \frac{M_p}{a} + 32\lambda - \frac{16\lambda}{a}$$

Thus the moment under the point load is:

$$M_c = 0.5 \cdot V_B = \frac{M_p}{2a} + 16\lambda - \frac{8\lambda}{a}$$

Substituting in the expression for λ from Eq. (1) previously:

$$M_c = \frac{M_p}{2a} + \left(16 - \frac{8}{a}\right) \left[\frac{M_p}{16} \left(\frac{a+1}{1-a} \right) \right]$$

Which after some algebra becomes:

$$M_c = M_p \left[\frac{a}{1-a} \right]$$

And so because $0.5 \leq a \leq 1.0$, $M_c \geq M_p$ as shown in the BMD. Only when $a = 0.5$ does $M_c = M_p$, which is of course the correct solution.

For the case of the hinge being between C and B, we have:

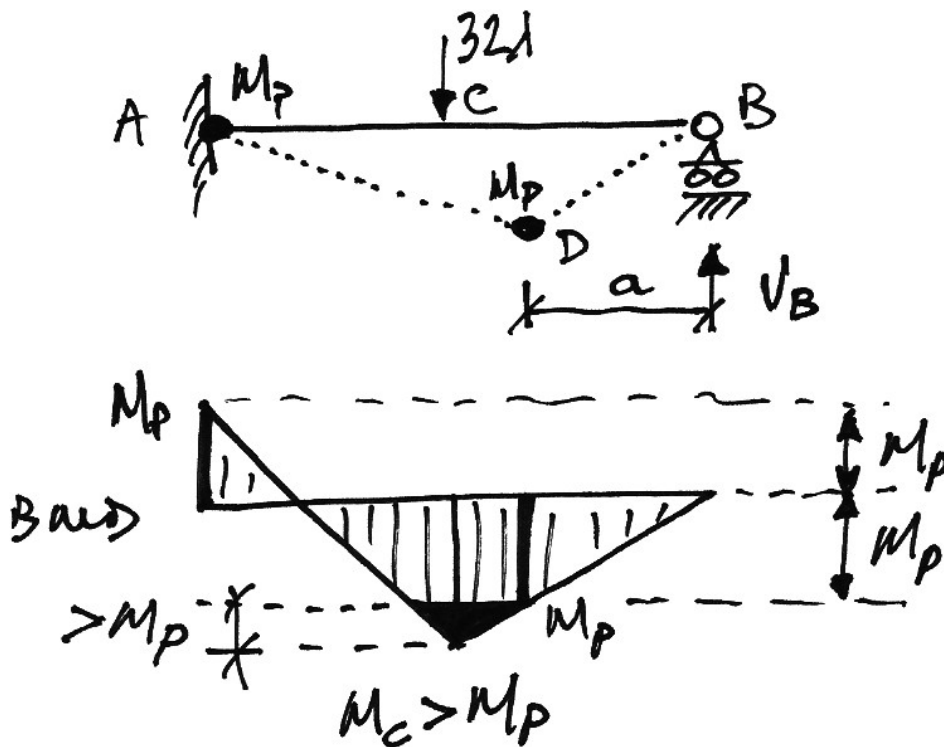

Again, we find the reaction V_B by considering the free body diagram DB :

$$\sum M \text{ about } D = 0 \quad \therefore M_p - V_B a = 0 \quad \therefore V_B = \frac{M_p}{a}$$

Thus the moment under the point load at C is:

$$M_c = M_p \left[\frac{1}{2a} \right]$$

And since $0 \leq a \leq 0.5$ then $\infty \leq 1/2a \leq 1$ and so $M_c \geq M_p$. Again only when $a = 0.5$ does $M_c = M_p$.

Summary

We have seen that for any position of the plastic hinge, other than at exactly C , the yield condition is not met. Therefore, in such cases, the Uniqueness Theorem tells us that the solution is not the correct one.

Notice that in these examples the mechanism and equilibrium conditions are always met. Therefore the Upperbound Theorem tells us that our solutions in such cases are either correct (as in when $a = 0.5$) or are unsafe (as in $\lambda > \lambda_c$).

In cases where one of the conditions of the Uniqueness Theorem is not met, we assume a different collapse mechanism and try again.

4.7 Plastic Design

Load Factor and Plastic Moment Capacity

When we come to design a structure using plastic methods, it is the load factor that is known in advance and it is the plastic moment capacity that is the objective. The general virtual work equations for a proposed collapse mechanism i is

$$\delta W_e = \delta W_I$$

$$\lambda_i \cdot \sum P_j \delta_{ji} = \sum M_{p,ji} \theta_{ji}$$

In which j is an individual load and deflection or plastic moment and rotation pair of collapse mechanism i . If we take the M_p of each member to be some factor, ϕ , of a nominal M_p , then we have:

$$\lambda_i \cdot \sum P_j \delta_{ji} = M_p \cdot \sum \phi_j \theta_{ji}$$

Since work is a scalar quantity, and since the sum of work done on both sides is positive, we can see that the load factor and plastic moment capacity have a linear relationship of slope m for each collapse mechanism i :

$$\lambda_i = M_p \cdot \frac{\sum \phi_j \theta_{ji}}{\sum P_j \delta_{ji}}$$

$$\lambda_i = m_i \cdot M_p$$

Thus for each collapse mechanism, $1 \leq k \leq n_m$, we can plot the load factor against the plastic moment capacity. We do so for two cases:

1. Load Factor Required – Design Plastic Moment Capacity Known:

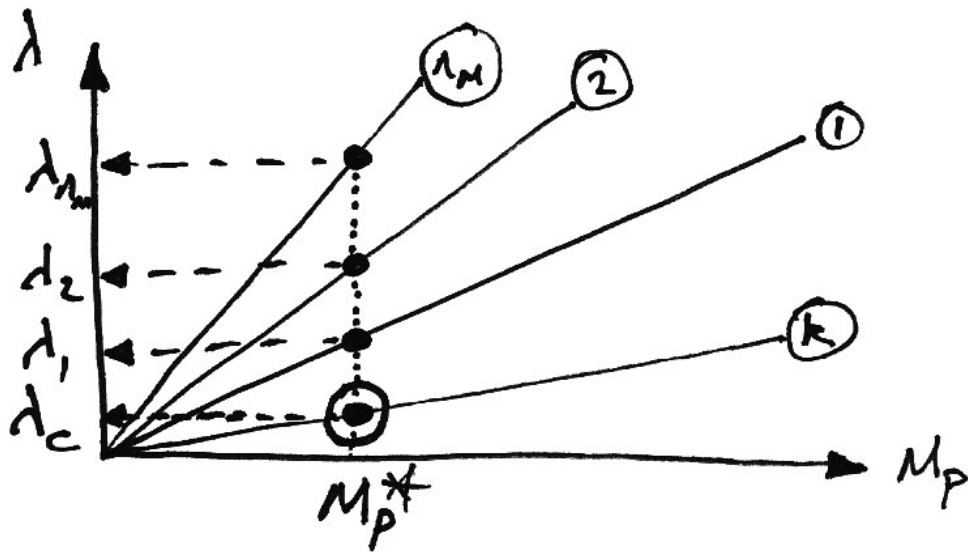

We can see from this graph that for a particular value of the plastic moment capacity, M_p^* , collapse mechanism k gives the lowest load factor and so by the Upperbound Theorem is the true collapse mechanism.

2. Design Load Factor Known – Plastic Moment Capacity Required:

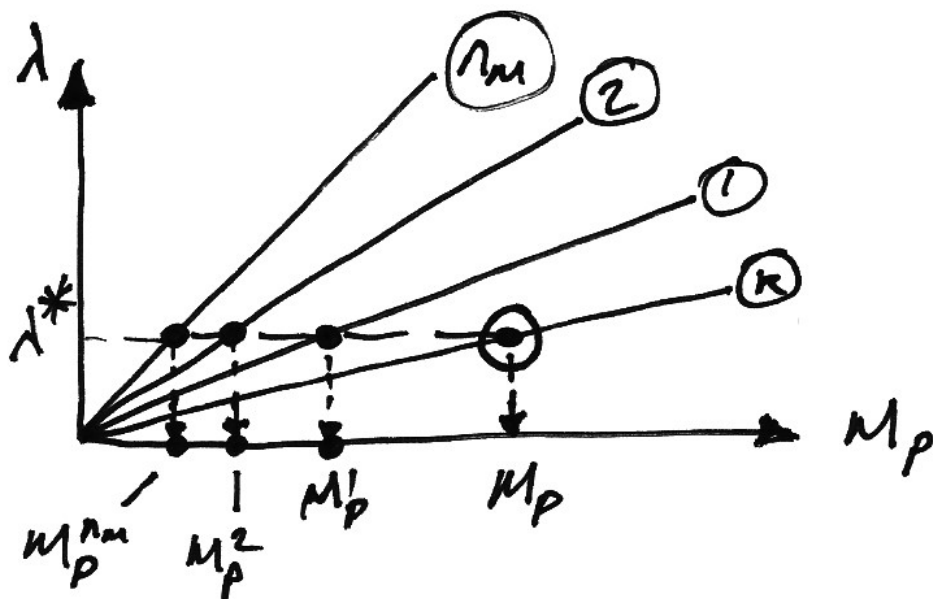

From this graph we can see that for a particular value of the load factor, λ^* , collapse mechanism k gives the highest design plastic moment capacity, M_p . However, since by the Upperbound Theorem we know collapse mechanism k to be the true collapse mechanism, it is therefore the highest value of M_p from each of the mechanisms that is required.

Mathematically, using the Upperbound Theorem, the above is summarized as:

$$\begin{aligned}\lambda_c &= \min \lambda_i \\ &= \min [m_i \cdot M_p] \\ &= M_p \min m_i\end{aligned}$$

Hence when the desired λ_c is specified:

$$\begin{aligned}M_p &= \frac{\lambda_c}{\min m_i} \\ &= \lambda_c \max \left[\frac{1}{m_i} \right] \\ M_p &= \lambda_c \max \left[\frac{\sum P_j \delta_{ji}}{\sum \phi_j \theta_{ji}} \right]\end{aligned}$$

In summary, if:

- Design plastic moment capacity is known – design for lowest load factor;
- Design load factor is known – design for highest plastic moment capacity.

4.8 Summary of Important Points

Number of Hinges Required for Collapse:

In general we require sufficient hinges to turn the structure into a mechanism, thus:

$$\begin{array}{l} \text{No. of Plastic} \\ \text{Hinges Required} \end{array} = \text{Indet} + 1$$

However, this does not apply in cases of local partial collapses.

The Three Theorems of Plastic Analysis:

<i>Criterion</i>	<i>Upperbound (Unsafe) Theorem</i>	<i>Lowerbound (Safe) Theorem</i>	<i>Unique Theorem</i>
Mechanism	} $\lambda \geq \lambda_c$	} $\lambda \leq \lambda_c$	} $\lambda = \lambda_c$
Equilibrium			
Yield			

Collapse Load Factor

By the Unsafe Theorem, which applies when the virtual work method is used:

$$\lambda_c = \min_{1 \leq i \leq n_m} \lambda_i$$

Design Value of Plastic Moment Capacity

The design value of M_p is the maximum of the design values for M_p from each collapse mechanism:

$$M_p = \max_{1 \leq i \leq n_m} M_{p,i}$$

5. Plastic Analysis of Beams

5.1 Example 1 – Fixed-Fixed Beam with Point Load

For the following beam, find the load at collapse, given that $M_p = 60$ kNm :

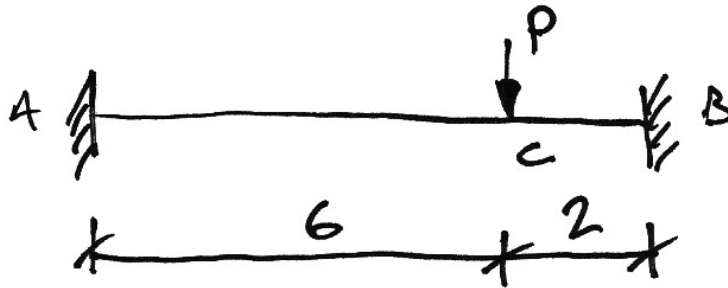

To start the problem, we examine the usual elastic BMD to see where the plastic hinges are likely to form:

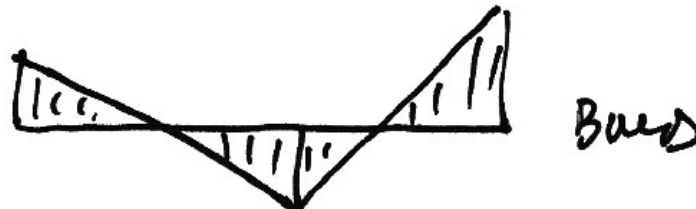

We also need to know how many hinges are required. This structure is 3° statically indeterminate and so we might expect the number of plastic hinges required to be 4. However, since one of the indeterminacies is horizontal restraint, removing it would not change the bending behaviour of the beam. Thus for a bending collapse only 2 indeterminacies apply and so it will only take 3 plastic hinges to cause collapse.

So looking at the elastic BMD, we'll assume a collapse mechanism with the 3 plastic hinges at the peak moment locations: A, B, and C.

Next, we impose a virtual rotation of θ to the plastic hinge at A and using the $S = R\theta$ rule, relate all other displacements to it, and then apply the virtual work equation:

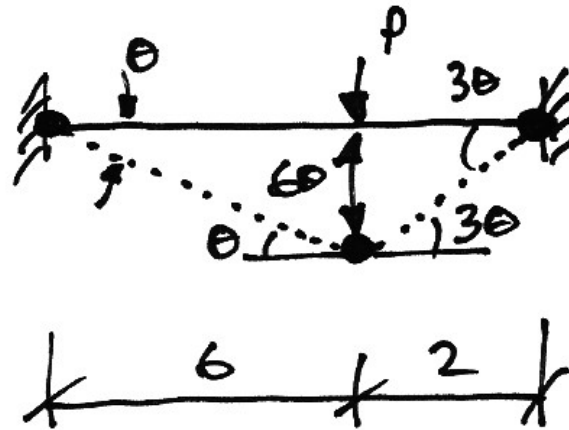

$$\delta W_e = \delta W_i$$

$$P(6\theta) = \underbrace{M_p(\theta)}_{\text{At A}} + \underbrace{M_p(\theta + 3\theta)}_{\text{At C}} + \underbrace{M_p(3\theta)}_{\text{At B}}$$

$$6P\theta = 8M_p\theta$$

$$P = \frac{8}{6}M_p$$

Since $M_p = 60$ kNm the load required for collapse is $P = 80$ kN and so the collapse BMD for this mechanism is:

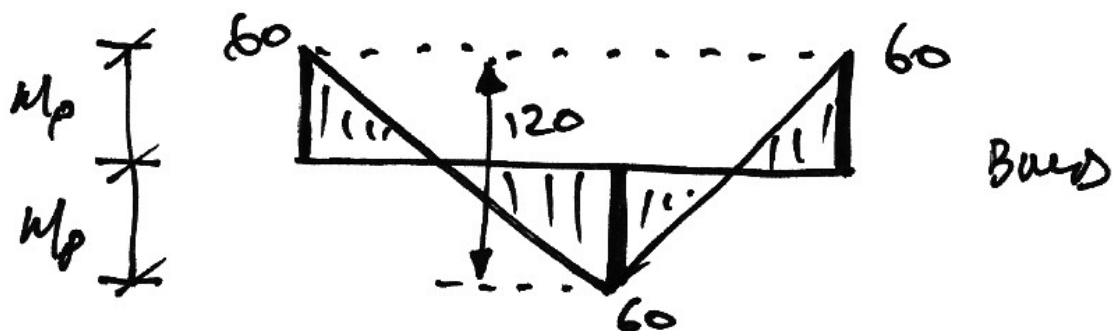

We need to check that this is the correct solution using the Uniqueness Theorem:

1. *Equilibrium:*

We'll check that the height of the free BMD is 120 kNm as per the collapse BMD:

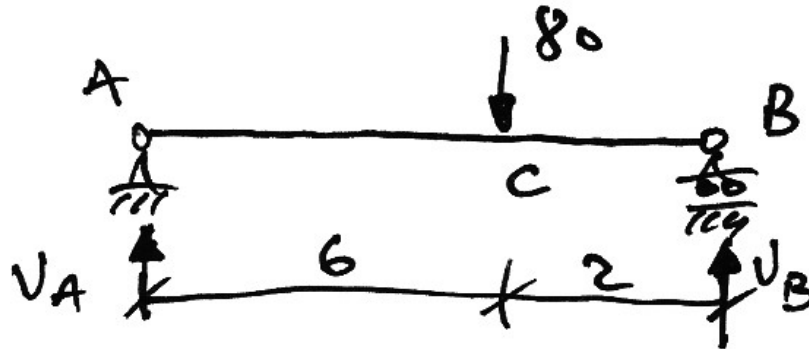

$$\sum M \text{ about } A = 0 \quad \therefore 80 \cdot 6 - 8V_B = 0 \quad \therefore V_B = 60 \text{ kN}$$

Thus, using a free body diagram of CB:

$$\sum M \text{ about } C = 0 \quad \therefore M_C - 2V_B = 0 \quad \therefore M_C = 120 \text{ kNm}$$

And so the applied load is in equilibrium with the free BMD of the collapse BMD.

2. *Mechanism:*

From the proposed collapse mechanism it is apparent that the beam is a mechanism.

3. *Yield:*

From the collapse BMD it can be seen that nowhere is M_p exceeded.

Thus the solution meets the three conditions and so, by the Uniqueness Theorem, is the correct solution.

5.2 Example 2 – Propped Cantilever with Two Point Loads

For the following beam, for a load factor of 2.0, find the required plastic moment capacity:

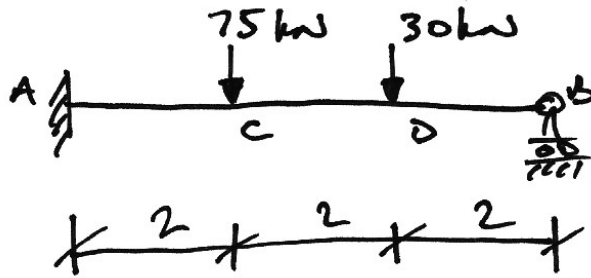

Allowing for the load factor, we need to design the beam for the following loads:

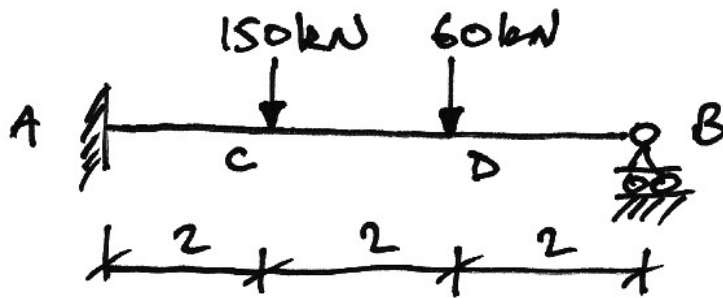

Once again we try to picture possible failure mechanisms. Since maximum moments occur underneath point loads, there are two real possibilities:

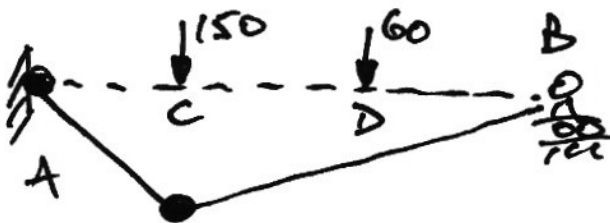

Mechanism 1: Plastic Hinge at C

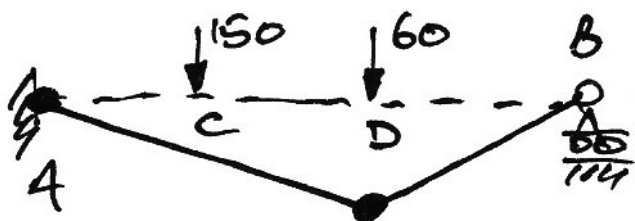

Mechanism 2: Plastic Hinge at D

Therefore, we analyse both and apply the Upperbound Theorem to find the design plastic moment capacity.

Mechanism 1: Plastic Hinge at C:

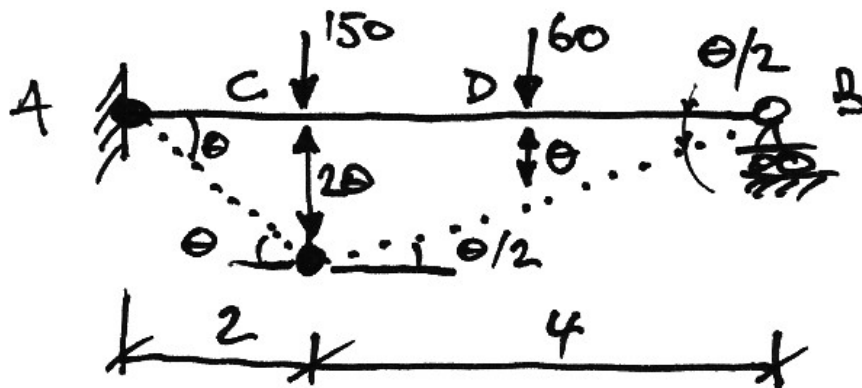

$$\delta W_e = \delta W_i$$

$$150(2\theta) + 60(\theta) = \underbrace{M_p(\theta)}_{\text{At A}} + \underbrace{M_p\left(\theta + \frac{\theta}{2}\right)}_{\text{At C}}$$

$$360\theta = \frac{5}{2}M_p\theta$$

$$M_p = 144 \text{ kNm}$$

Mechanism 2: Plastic Hinge at D:

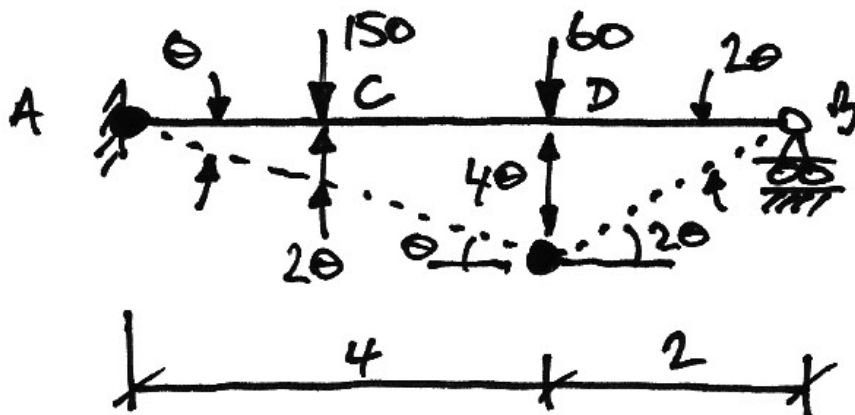

$$\delta W_e = \delta W_i$$

$$150(2\theta) + 60(4\theta) = \underbrace{M_p(\theta)}_{\text{At A}} + \underbrace{M_p(\theta + 2\theta)}_{\text{At D}}$$

$$540\theta = 4M_p\theta$$

$$M_p = 135 \text{ kNm}$$

So by the application of the Upperbound theorem for the design plastic capacity, we choose $M_p = 144 \text{ kNm}$ as the design moment and recognize Mechanism 1 to be the correct failure mechanism. We check this by the Uniqueness Theorem:

1. *Equilibrium:*

Using the BMD at collapse, we'll check that the height of the free BMD is that of the equivalent simply-supported beam. Firstly the collapse BMD from Mechanism 1 is:

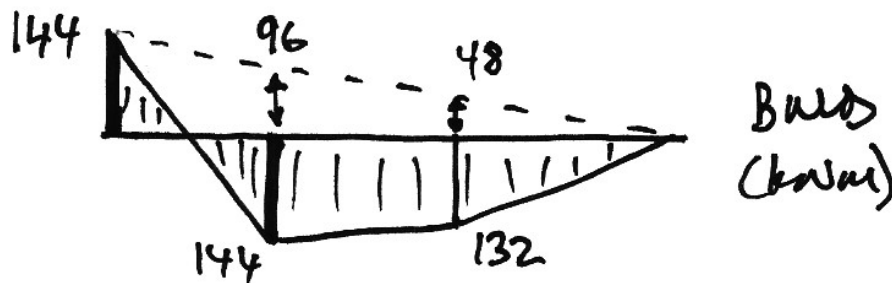

Hence, the total heights of the free BMD are:

$$M_c = 96 + 144 = 240 \text{ kNm}$$

$$M_d = 48 + 132 = 180 \text{ kNm}$$

Checking these using a simply-supported beam analysis:

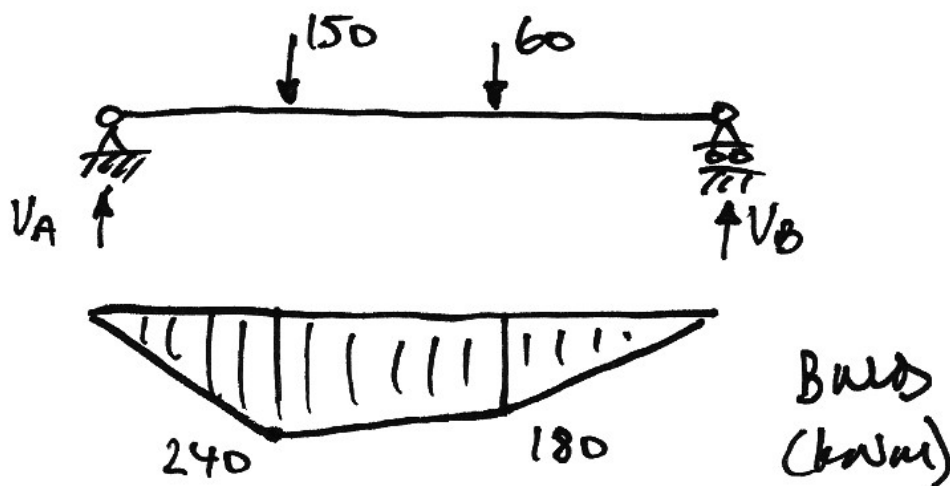

$$\begin{aligned} \sum M \text{ about } A = 0 & \quad \therefore 150 \cdot 2 + 60 \cdot 4 - 6V_B = 0 \quad \therefore V_B = 90 \text{ kN} \\ \sum F_y = 0 & \quad \therefore 150 + 60 - 90 - V_A = 0 \quad \therefore V_A = 120 \text{ kN} \end{aligned}$$

Thus, using appropriate free body diagrams of AC and DB:

$$M_C = 120 \cdot 2 = 240 \text{ kNm}$$

$$M_D = 90 \cdot 2 = 180 \text{ kNm}$$

And so the applied load is in equilibrium with the free BMD of the collapse BMD.

2. Mechanism:

From the proposed collapse mechanism it is apparent that the beam is a mechanism. Also, since it is a propped cantilever and thus one degree indeterminate, we require two plastic hinges for collapse, and these we have.

3. Yield:

From the collapse BMD it can be seen that nowhere is the design $M_p = 144 \text{ kNm}$ exceeded.

Thus by the Uniqueness Theorem we have the correct solution.

Lastly, we'll examine why the Mechanism 2 collapse is not the correct solution. Since the virtual work method provides an upperbound, then, by the Uniqueness Theorem, it must not be the correct solution because it must violate the yield condition.

Using the collapse Mechanism 2 to determine reactions, we can draw the following BMD for collapse Mechanism 2:

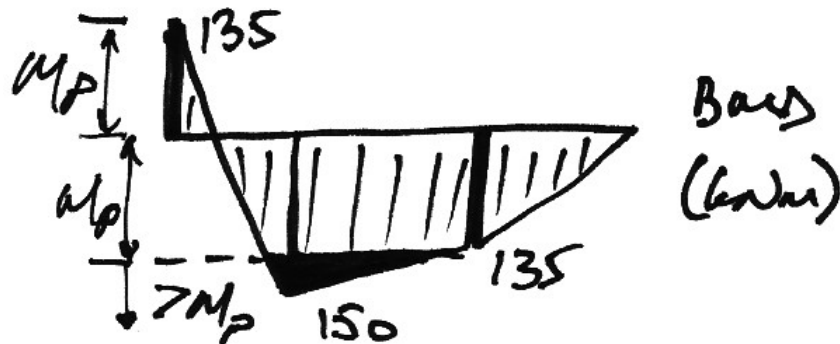

From this it is apparent that Mechanism 2 is not the unique solution, and so the design plastic moment capacity must be 144 kNm as implied previously from the Upperbound Theorem.

5.3 Example 3 – Propped Cantilever under UDL

For the general case of a propped cantilever, find the locations of the plastic hinges at collapse, and express the load at collapse in terms of the plastic moment capacity.

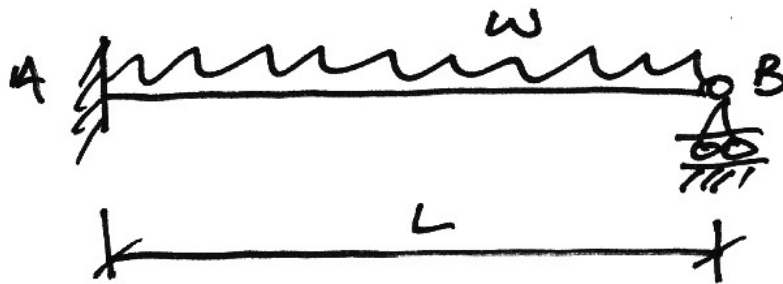

When considering UDLs, it is not readily apparent where the plastic hinge should be located in the span. For this case of a propped cantilever we require 2 hinges, one of which will occur at A, as should be obvious. However, we need to keep the location of the span hinge variable at say, aL , from A:

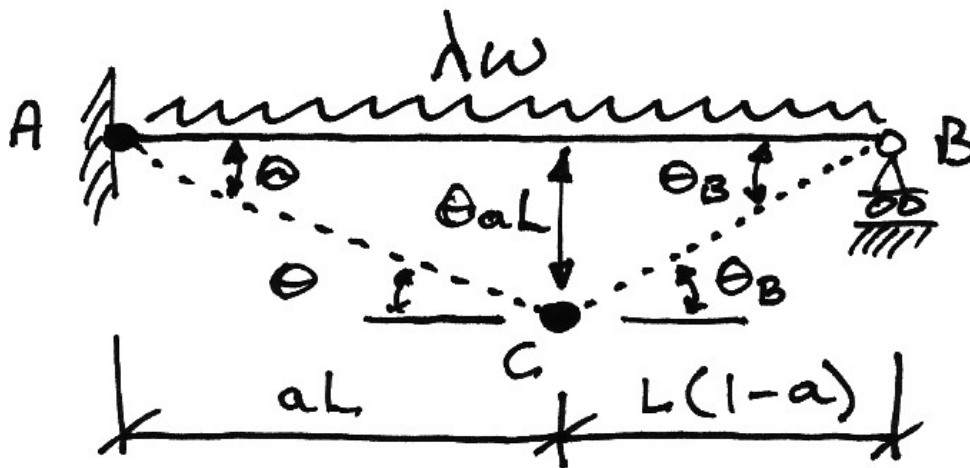

Using $S = R\theta$, we find the rotation at B:

$$\theta_{aL} = L(1-a)\theta_B$$

And so:

$$\theta_B = \theta \cdot \frac{a}{(1-a)}$$

Thus, noting that the external work done by a UDL is the average distance it moves, we have:

$$\begin{aligned} \delta W_e &= \delta W_i \\ (\lambda w L) \left(\frac{\theta a L}{2} \right) &= \underbrace{M_p(\theta)}_{\text{At A}} + \underbrace{M_p \left(\theta + \theta \cdot \frac{a}{1-a} \right)}_{\text{At C}} \\ \frac{\lambda w a L^2}{2} \theta &= M_p \theta \left(2 + \frac{a}{1-a} \right) \\ \frac{\lambda w a L^2}{2} &= M_p \left(\frac{2-a}{1-a} \right) \\ \lambda &= \frac{2M_p}{w a L^2} \left(\frac{2-a}{1-a} \right) \end{aligned}$$

If we introduce a non-dimensional quantity, $K \equiv M_p / wL^2$, we have:

$$\lambda = K \cdot \frac{2}{a} \left(\frac{2-a}{1-a} \right)$$

Thus the collapse load factor is a function of the position of the hinge, a , as expected. Also, we can plot the function λ/K against a to visualize where the minimum might occur:

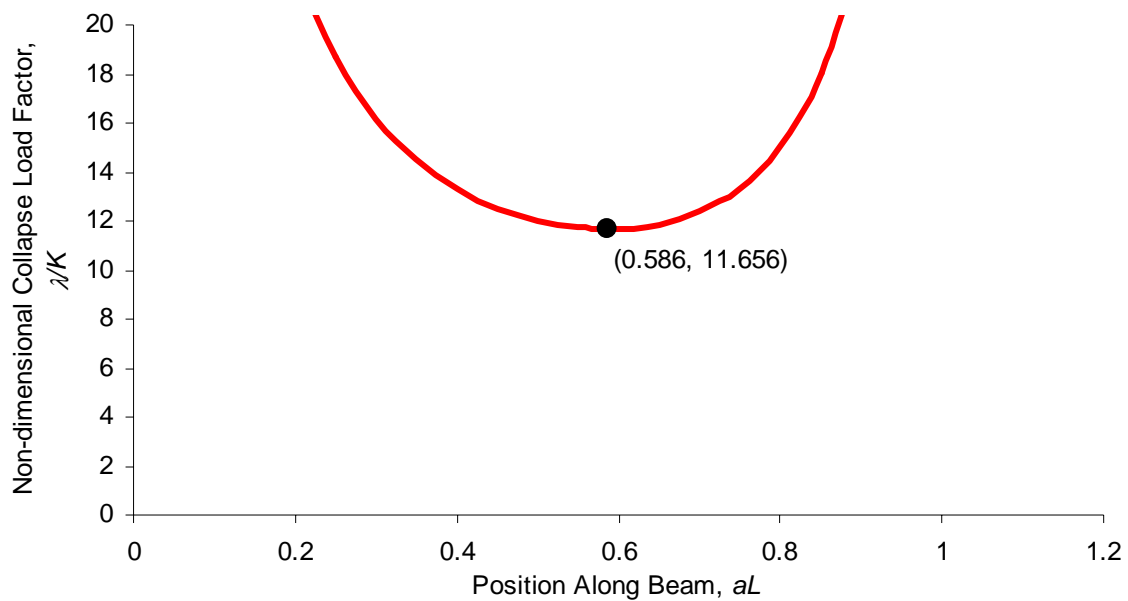

To determine the critical collapse load factor, using the Upperbound Theorem, we look for the minimum load factor using:

$$\frac{d\lambda}{da} = 0$$

To do this, we'll expand the fraction:

$$\lambda = K \cdot \frac{2}{a} \left(\frac{2-a}{1-a} \right) = K \cdot \frac{4-2a}{a-a^2}$$

Using the quotient rule for derivatives:

$$\frac{dy}{dx} = \frac{v \frac{du}{dx} - u \frac{dv}{dx}}{v^2}$$

$$\frac{d\lambda}{da} = \frac{(a-a^2)(-2) - (4-2a)(1-2a)}{(a-a^2)^2} = 0$$

Thus multiplying across by $(a - a^2)^2$ and simplifying gives:

$$-2a^2 + 8a - 4 = 0$$

Thus:

$$\begin{aligned} a &= \frac{-8 \pm \sqrt{8^2 - 4(-2)(-4)}}{2(-2)} \\ &= 2 \pm \sqrt{2} \end{aligned}$$

Since we know $0 \leq a \leq 1$, then:

$$a = 2 - \sqrt{2} = 0.586$$

At this value for a , the collapse load factor is:

$$\begin{aligned} \lambda_c &= \frac{M_p}{wL^2} \cdot \frac{2}{0.586} \left(\frac{2 - 0.586}{1 - 0.586} \right) \\ &= 11.656 \frac{M_p}{wL^2} \end{aligned}$$

These values are shown in the graph previously. The collapse BMD is:

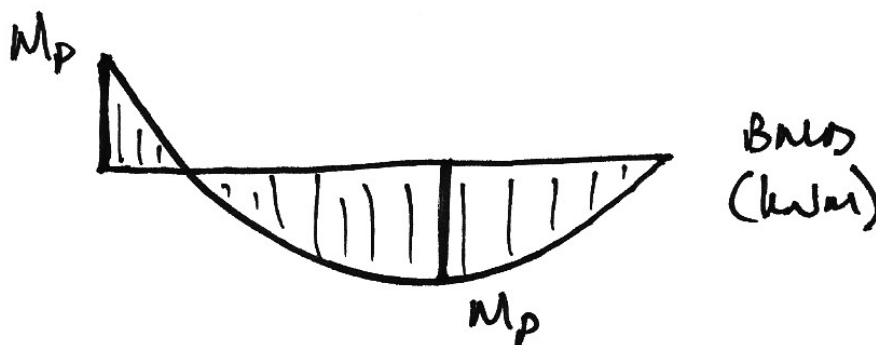

The propped cantilever is a good structure to illustrate the use of the Lowerbound Theorem. Consider the standard elastic BMD for this structure which meets the equilibrium condition:

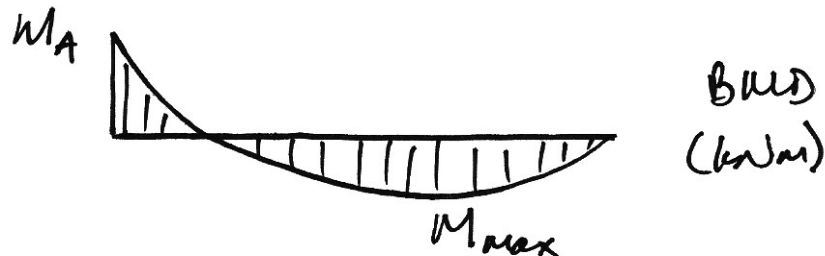

$$M_A = \frac{wL^2}{8} \quad M_{max} = \frac{9wL^2}{128}$$

If we increase the load by a load factor λ so that $M_A = M_p$, and since $M_{max} < M_A$ we meet the yield condition, then we have:

$$M_p = \frac{\lambda wL^2}{8}$$

$$\lambda = 8 \frac{M_p}{wL^2} < \lambda_c = 11.656 \frac{M_p}{wL^2}$$

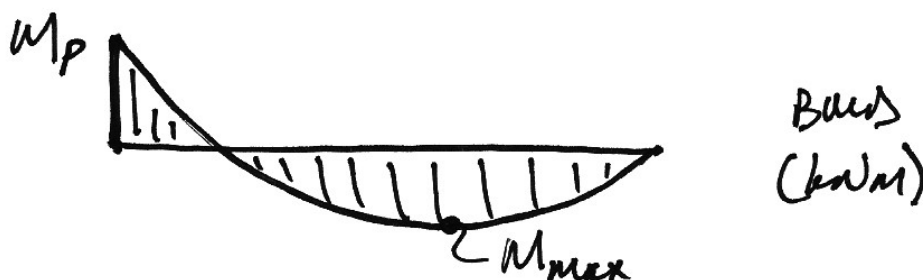

By meeting the equilibrium and yield conditions, but not the mechanism condition, we have a lowerbound on the critical load factor without doing the virtual work analysis. This is one of the main reasons elastic analyses are mostly used in practice.

5.4 Continuous Beams

Common but Special Case

We consider there a common but special case of continuous beam. Purlins and other forms of continuous beams fall into this category. The limitations are:

- All spans are equal;
- The beam is prismatic (so all spans have equal M_p);
- All spans are subject to an equal UDL.

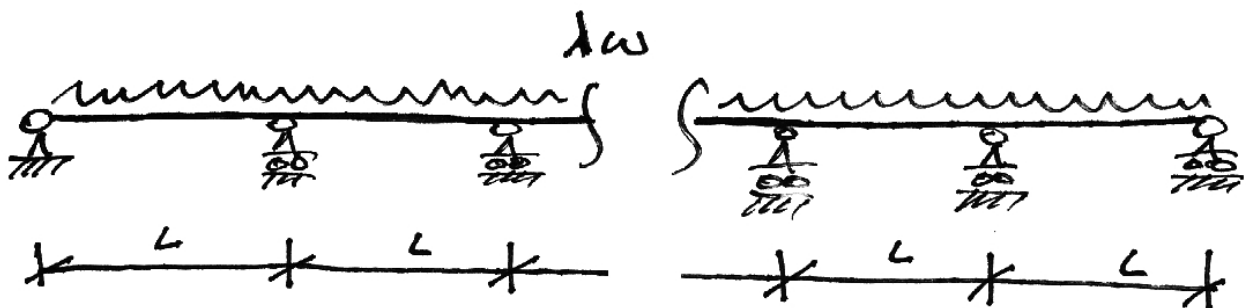

In this case, an overall collapse of the structure cannot occur. Instead, collapse must occur in one (or more) of the spans separately. However, there are only two types of spans: interior and end spans. We will consider these in turn.

Interior Span

The collapse mechanism for a typical interior span is given below:

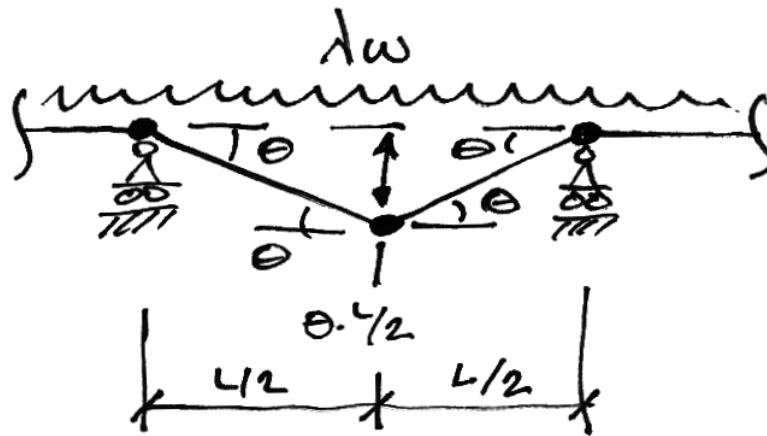

Carrying out the virtual work analysis gives:

$$(\lambda w L) \left(\frac{1}{2} \theta \frac{L}{2} \right) = M_p \theta + 2M_p \theta + M_p \theta$$

$$\frac{\lambda w L^2}{4} \theta = 4M_p \theta$$

Thus:

$$M_p = \frac{\lambda w L^2}{16} \quad \lambda_c = \frac{16M_p}{wL^2}$$

End Span

The collapse mechanism for the end spans is given below:

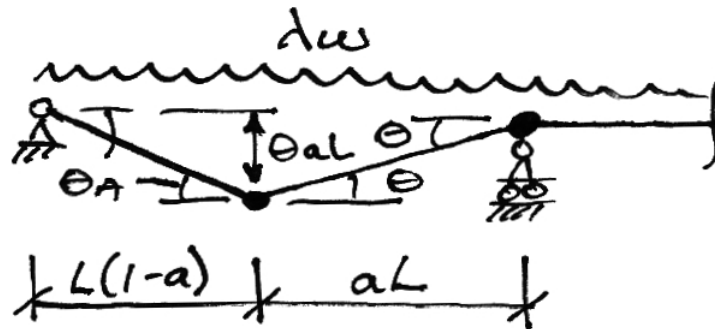

In this case we do not know immediately where the second hinge is to be located. However, comparison with the propped cantilever analysis of Example 3 shows that the analysis is the same. Thus the results is:

$$M_p = \frac{\lambda w L^2}{11.656} \qquad \lambda_c = 11.656 \frac{M_p}{w L^2}$$

Discussion

Immediately obvious from the forgoing analysis is that the end spans govern the design of the beam: they require a plastic moment capacity 37% ($16/11.656$) greater than the interior spans do.

Two possible solutions to this are apparent:

1. Strengthen the end spans: provide a section of 37% greater capacity for the end span. Noting that the plastic hinge must form over the first interior support, the connection (or splice) between the two beam sections should therefore occur at the point of contraflexure in the penultimate span (about $0.2L$ inside the span).
2. Choose the span lengths so that a beam of prismatic section is optimized. The ratio of lengths must be such that the plastic moments required are the same:

$$M_p = \frac{\lambda w L_{int}^2}{16} = \frac{\lambda w L_{End}^2}{11.656}$$
$$\frac{L_{End}}{L_{int}} = \sqrt{\frac{11.656}{16}} = 0.853$$

Thus the most economic design is one where the end spans are 85% of the interior spans.

Lastly, since it is a single span that is considered to collapse at a time (and not the overall structure), the number of hinges required is $h \leq r + 1$ and so the collapse of a continuous beam is always a partial or complete collapse.

5.5 Example 4 – Continuous Beam

We will analyse the following beam for the loads:

$$w_1 = 10 \text{ kN/m}, P_1 = 45 \text{ kN}, w_2 = 30 \text{ kN/m}, P_2 = 60 \text{ kN}$$

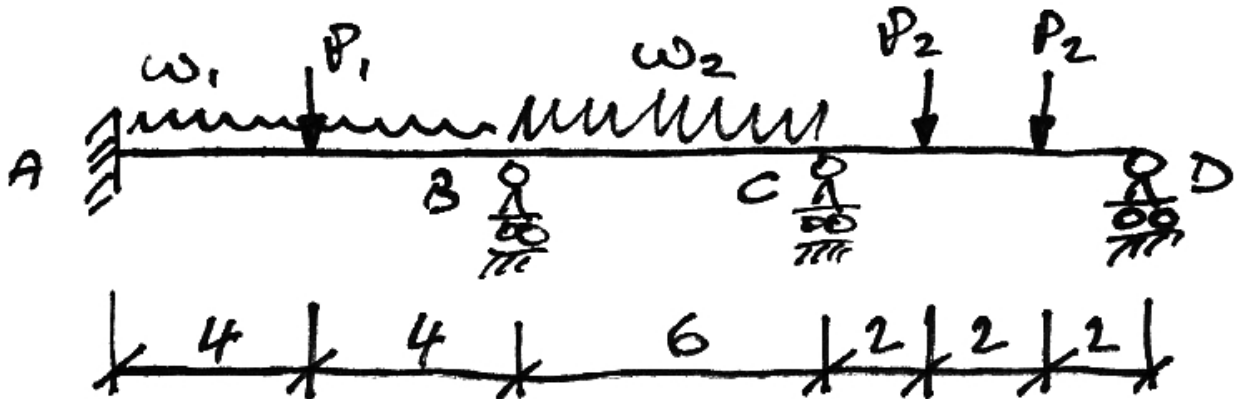

We carry out the analysis using the Equilibrium Method (since we have used the Kinematic Method mostly so far).

Firstly we draw the free bending moment diagrams, having chosen the redundants to be the moments over the supports:

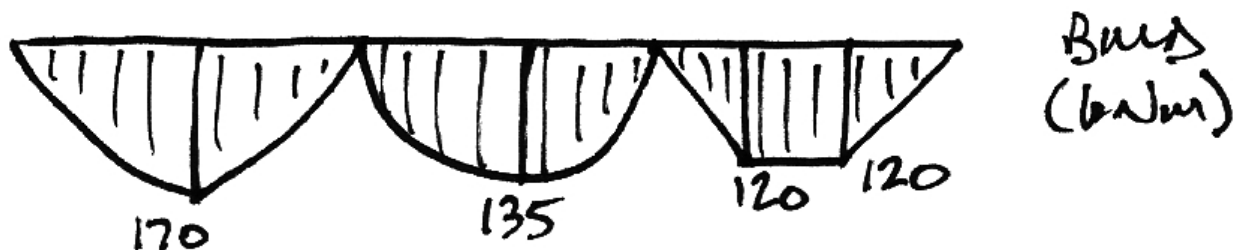

Since each span can be considered to collapse separately, we draw the composite diagrams and write the equilibrium equations for each span separately:

Span AB:

Note for this span we must take $M_A = M_B$ since it requires three hinges to fail and one plastic hinge moment cannot be greater than another (the beam is prismatic):

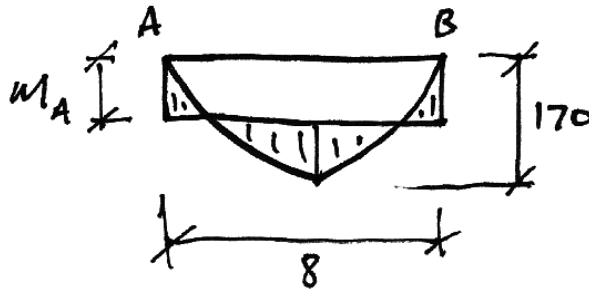

$$M_{Mid} = 170 - M_A$$

Thus if all three moments are to be equal to M_p at collapse, we have:

$$M_p = 170 - M_p$$

$$2M_p = 170$$

$$M_p = 85 \text{ kNm}$$

Span BC:

Similarly to span AB, we need three hinges and so $M_B = M_C$:

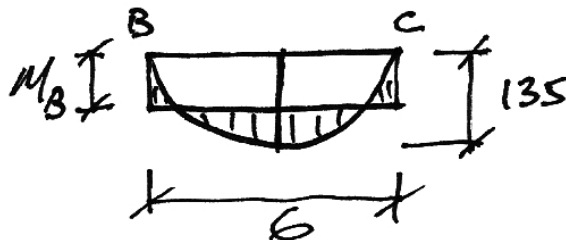

$$M_{Mid} = 135 - M_B$$

At collapse, we again have all moments equal to M_p :

$$M_p = 135 - M_p$$

$$2M_p = 135$$

$$M_p = 67.5 \text{ kNm}$$

Span BC:

For Span BC we only need two hinges due to the pinned end support:

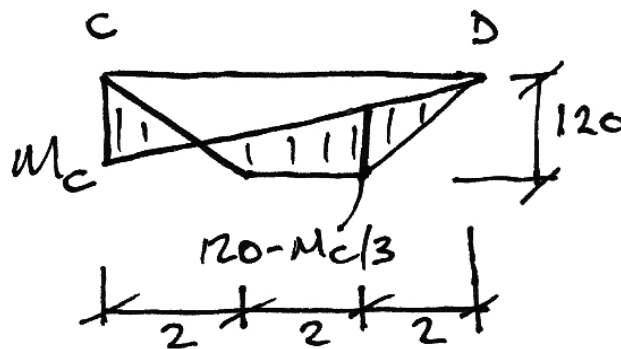

$$M_{Mid} = 120 - \frac{1}{3}M_c$$

At collapse, both moments are equal to M_p :

$$M_p = 120 - \frac{1}{3}M_p$$

$$\frac{4}{3}M_p = 120$$

$$M_p = 90 \text{ kNm}$$

Thus the largest plastic moment capacity required is 90 kNm and this is therefore the solution. The bending moment diagram corresponding to this case is:

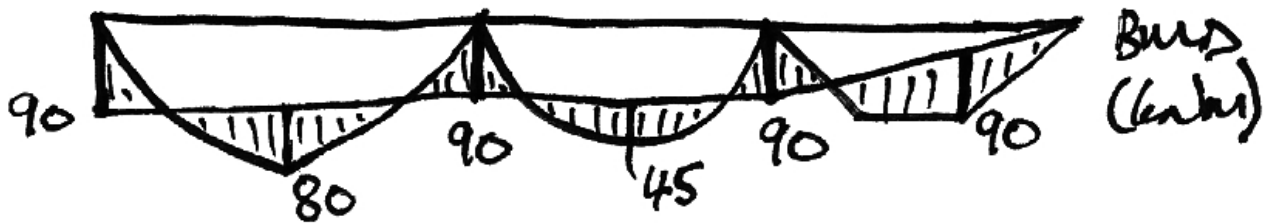

Considering the three criteria for collapse, we have:

1. Equilibrium: met (almost automatically) through consideration of the free and reactant bending moments diagrams;
2. Yield: As can be seen from the BMD above, no moment is greater than M_p and so this condition is met;
3. Mechanism: The end span CD has two hinges and has thus collapsed. This is a partial collapse of the overall structure.

Since the three conditions are met, our solution is unique and this correct.

Lastly, note that for the Spans AB and BC , the reactant line does not have to be horizontal as shown. Indeed it can lie in any region that maintains the following equilibrium and yield conditions:

$$|M_A| \leq M_p \quad |M_{Mid,AB}| \leq M_p \quad |M_B| \leq M_p \quad |M_{Mid,BC}| \leq M_p$$

It is worthwhile to sketch out this region:



5.6 Problems

1. For the following prismatic beam of $M_p = 30$ kNm, find the load factor at collapse. (Ans. 1.5)

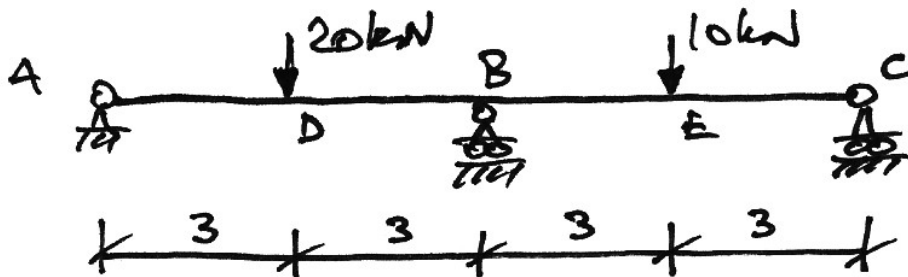

2. For the following prismatic beam of $M_p = 30$ kNm, find the load factor at collapse. (Ans. 1.33)

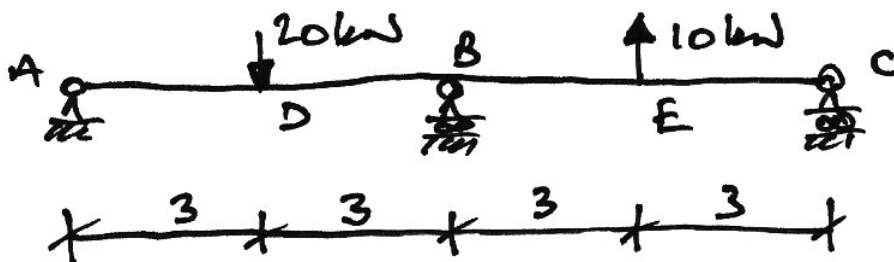

3. For the following prismatic beam of $M_p = 86$ kNm, find the load factor at collapse. (Ans. 1.27)

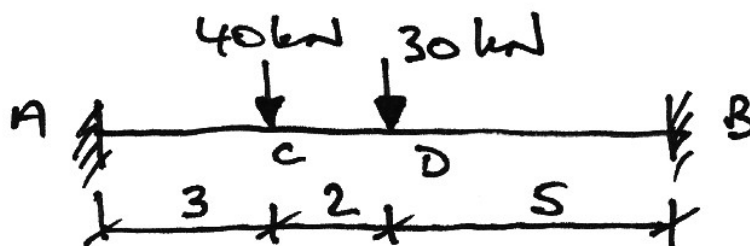

4. For the beam of Example 4, determine the required plastic moment capacity for the loads: $w_1 = 10 \text{ kN/m}$, $P_1 = 50 \text{ kN}$, $w_2 = 40 \text{ kN/m}$, $P_2 = 60 \text{ kN}$. What is special about this particular case? (Ans. 90 kNm)

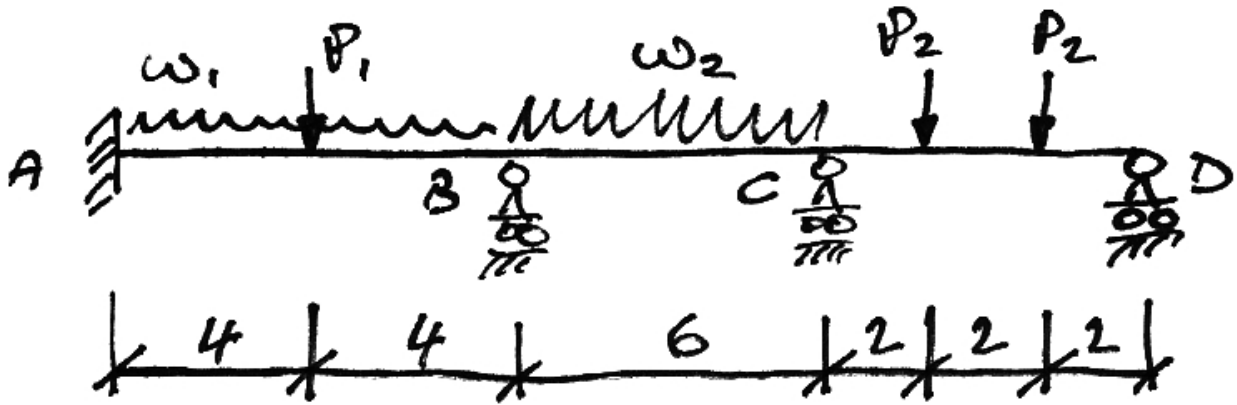

6. Plastic Analysis of Frames

6.1 Additional Aspects for Frames

Basic Collapse Mechanisms

In frames, the basic mechanisms of collapse are:



Beam-type collapse

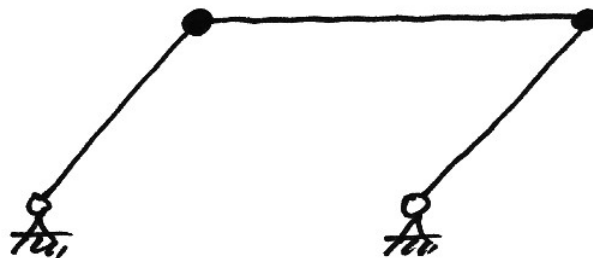

Sway Collapse

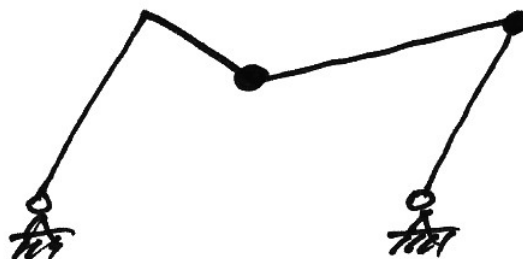

Combination Collapse

Location of Plastic Hinge at Joints

In frames where members of different capacities meet at joints, it is the weaker member that develops the plastic hinge. So, for example:

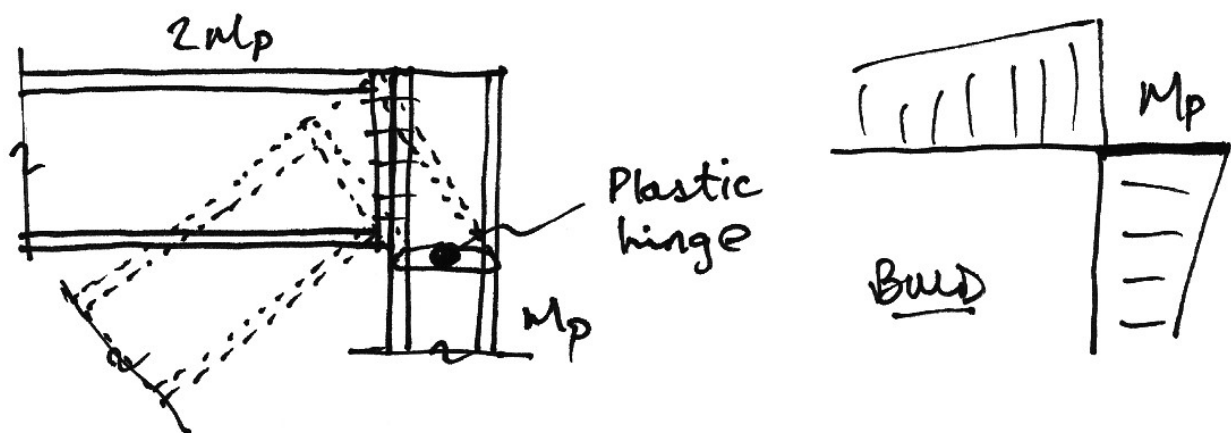

The plastic hinge occurs in the column and not in the beam section since the column section is weaker.

This is important when calculating the external virtual work done.

Combination of Mechanisms

One of the most powerful tools in plastic analysis is Combination of Mechanisms. This allows us to work out the virtual work equations for the beam and sway collapses separately and then combine them to find the collapse load factor for a combination collapse mechanism.

Combination of mechanisms is based on the idea that there are only a certain number of independent equilibrium equations for a structure. Any further equations are obtained from a combination of these independent equations. Since equilibrium equations can be obtained using virtual work applied to a possible collapse mechanism, it follows that there are independent collapse mechanisms, and other collapse mechanisms that may be obtained from a combination of the independent collapse mechanisms.

As we saw for the propped cantilever case of one redundant ($r = 1$), we required two hinges, $h = 2$ for collapse, and wrote one independent equilibrium equation $M_C = PL/4 - M_A$. Generally, there are $h - r$ independent equilibrium equations, and thus $h - r$ independent collapse mechanisms.

It must be noted here that in combining collapse mechanisms it is essential that hinges rotating in opposing senses must be cancelled to avoid having two degrees of freedom.

The method is better explained by the examples that follow.

6.2 Example 5 –Portal Frame with Multiple Loads

Find the collapse load in terms of the plastic moment capacity:

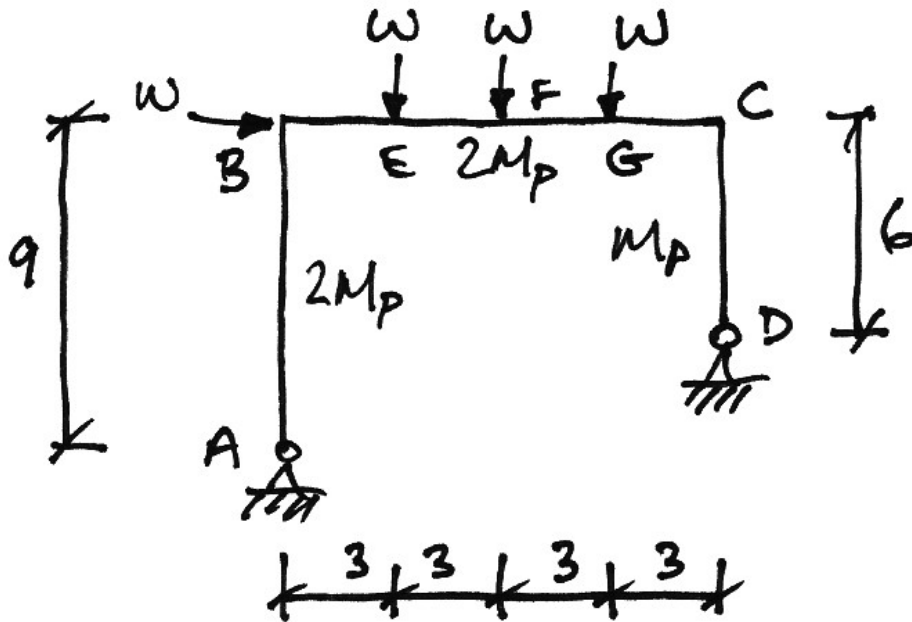

Using the idea of Combination of Mechanisms, we will analyse the beam and sway mechanisms separately, and then combine them in various ways to achieve a solution.

Beam Collapse Mechanism:

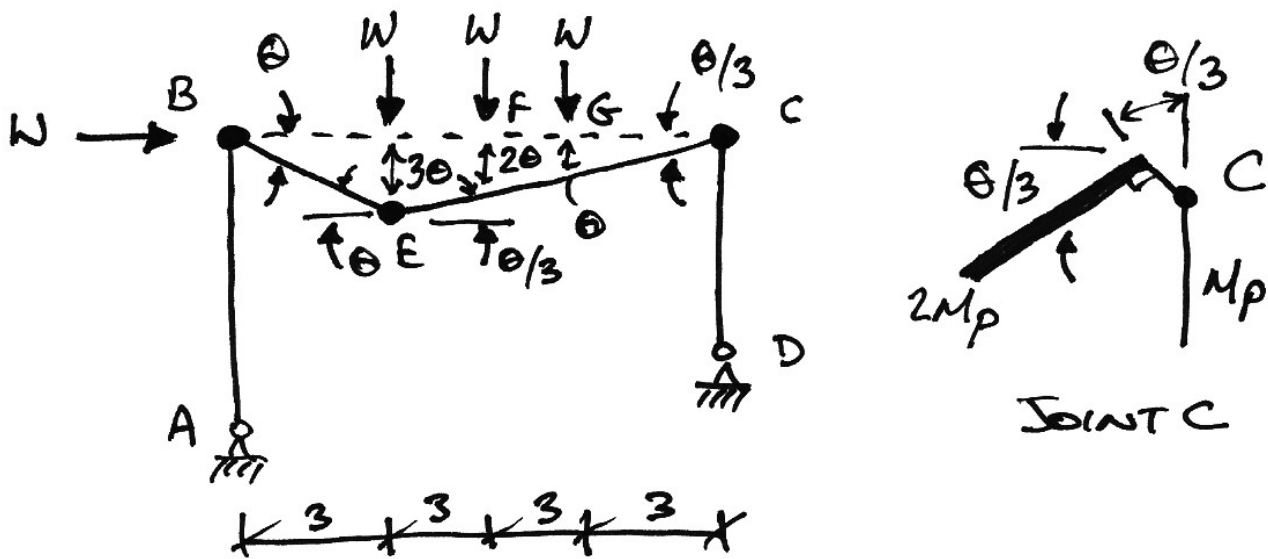

Notice that, as previously mentioned, we must take the plastic hinge at joint C to be in the column which has the smaller M_p . Applying the virtual work equation:

$$\delta W_e = \delta W_i$$

$$\underbrace{W(3\theta)}_{\text{At E}} + \underbrace{W(2\theta)}_{\text{At F}} + \underbrace{W(\theta)}_{\text{At G}} = \underbrace{2M_p(\theta)}_{\text{At B}} + \underbrace{2M_p\left(\frac{4}{3}\theta\right)}_{\text{At E}} + \underbrace{M_p\left(\frac{1}{3}\theta\right)}_{\text{At C}}$$

$$6W\theta = 5M_p\theta$$

$$W = \frac{5}{6}M_p$$

Sway Collapse Mechanism:

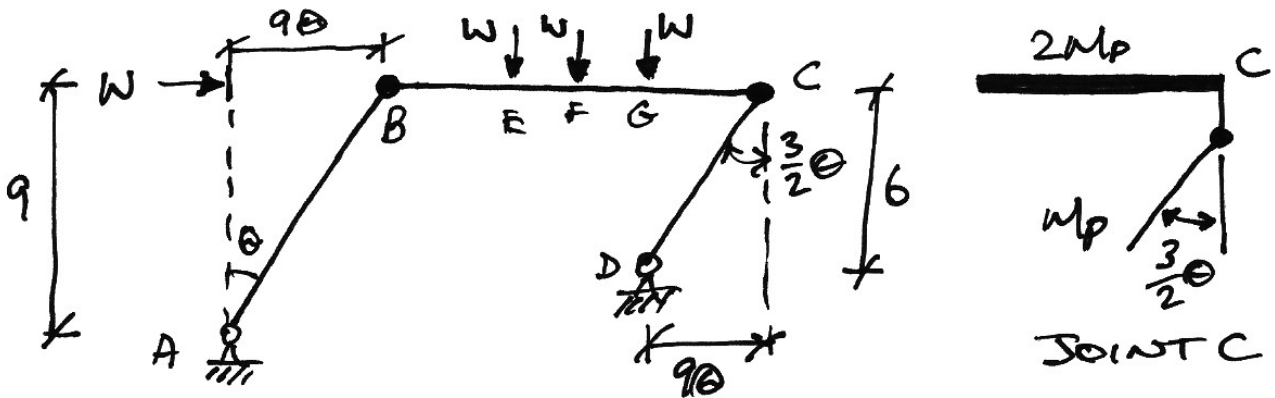

Again notice how careful we are of the hinge location at joint C.

$$\delta W_e = \delta W_i$$

$$\underbrace{W(9\theta)}_{\text{At B}} = \underbrace{2M_p(\theta)}_{\text{At B}} + \underbrace{M_p\left(\frac{3}{2}\theta\right)}_{\text{At C}}$$

$$9W\theta = 3.5M_p\theta$$

$$W = \frac{7}{18}M_p$$

Combined Collapse Mechanism

To arrive at a solution, we want to try to minimize the collapse load value. Examining the previous equations, this means that we should try to maximize the external work done and minimize the internal work done. So:

- To maximize the external work done we need to make every load move through some displacement, unlike the sway mechanism;
- To minimize the internal work done we try to remove a hinge, whilst maintaining a mechanism.

Based on the above try the following:

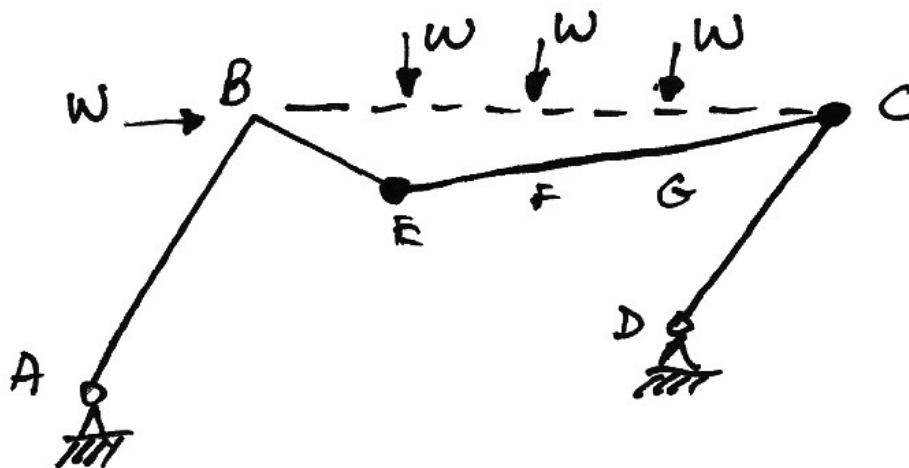

Instead of using virtual work, we can combine the equations already found:

- External virtual work: Since all forces move through displacements:

$$\delta W_e = \underbrace{6W\theta}_{\text{Beam}} + \underbrace{9W\theta}_{\text{Sway}} = 15W\theta$$

- Internal virtual work: we can add but we must remove the work done by the hinge at B for both the beam and sway mechanisms (i.e. cancel the hinge):

$$\delta W_i = \underbrace{5M_p\theta}_{\text{Beam}} + \underbrace{3.5M_p\theta}_{\text{Sway}} - \underbrace{2M_p\theta}_{\text{Hinge B - Beam}} - \underbrace{2M_p\theta}_{\text{Hinge B - Sway}} = 4.5M_p\theta$$

Thus we have:

$$\begin{aligned} \delta W_e &= \delta W_i \\ 15W\theta &= 4.5M_p\theta \\ W &= \frac{3}{10}M_p \end{aligned}$$

Since this is lower than either of the previous mechanisms, we think this is the solution, and so check against the three conditions of the Uniqueness Theorem.

To prove that the combination of mechanisms works, we do the virtual work analysis:

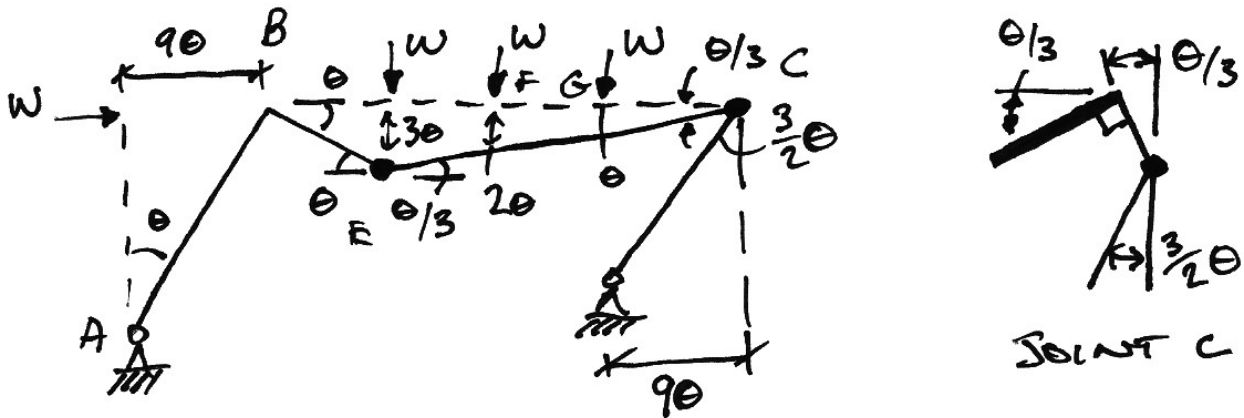

$$\begin{aligned} \delta W_e &= \delta W_i \\ \underbrace{W(9\theta)}_{\text{At B}} + \underbrace{W(3\theta)}_{\text{At E}} + \underbrace{W(2\theta)}_{\text{At F}} + \underbrace{W(\theta)}_{\text{At G}} &= \underbrace{2M_p\left(\frac{4}{3}\theta\right)}_{\text{At E}} + \underbrace{M_p\left(\frac{3}{2}\theta + \frac{1}{3}\theta\right)}_{\text{At C}} \\ 15W\theta &= 4.5M_p\theta \\ W &= \frac{3}{10}M_p \end{aligned}$$

Check for the three conditions, recognizing that $M_p = \frac{W}{0.3} = 3.33W$

1. *Equilibrium:*

We start by determining the reactions:

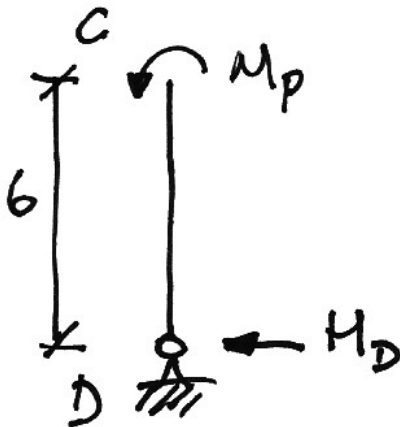

$$\sum M \text{ about } C = 0 \quad \therefore 6H_D - M_p = 0$$

$$\therefore H_D = \frac{M_p}{6} = \frac{3.33W}{6} = 0.55W$$

$$\sum F_x = 0 \quad \therefore H_A = W - 0.55W = 0.45W$$

For the whole frame:

$$\sum M \text{ about } D = 0 \quad \therefore 12V_A + 3H_A + 6W - 9W - 6W - 3W = 0 \quad \therefore V_A = 0.89W$$

Thus the moment at E , from a free-body diagram of ABE , is:

$$\sum M \text{ about } E = 0 \quad \therefore 3V_A + 9H_A - M_E = 0 \quad \therefore M_E = 6.71W$$

Since there is a plastic hinge at E of value $2M_p = 2 \cdot (3.33W) = 6.67W$ we have equilibrium.

2. *Mechanism:*

The frame is obviously a mechanism since $R - C - 3 = 4 - 2 - 3 = -1$.

3. *Yield:*

To verify yield we draw the collapse BMD from the reactions:

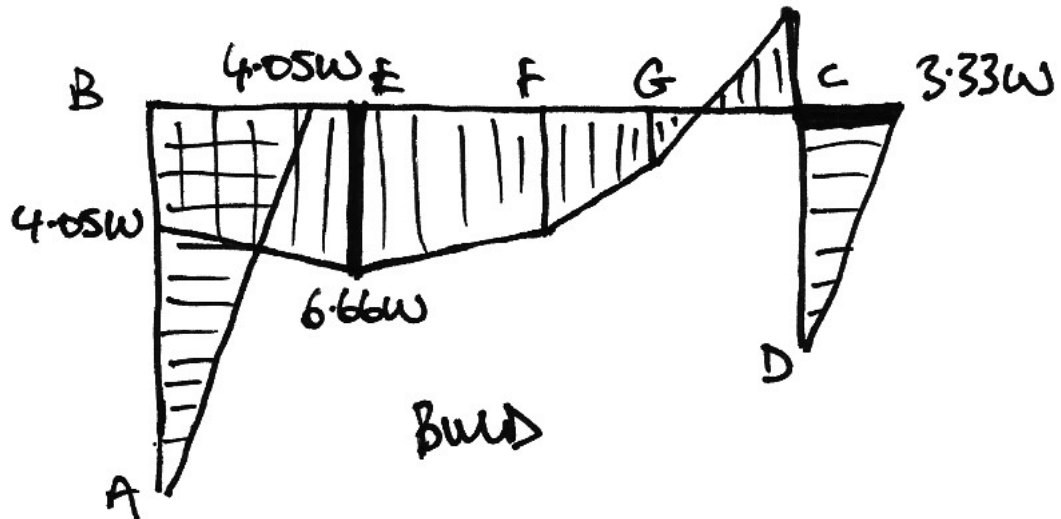

From the diagram we see that there are no moments greater than $2M_p = 6.67W$ in members AB and BC , and no moments greater than $M_p = 3.33W$ in member CD .

6.3 Example 6 – Portal Frame with Crane Loads, Summer 1997

For the following frame, find the plastic moment capacity required for collapse under the loads given.

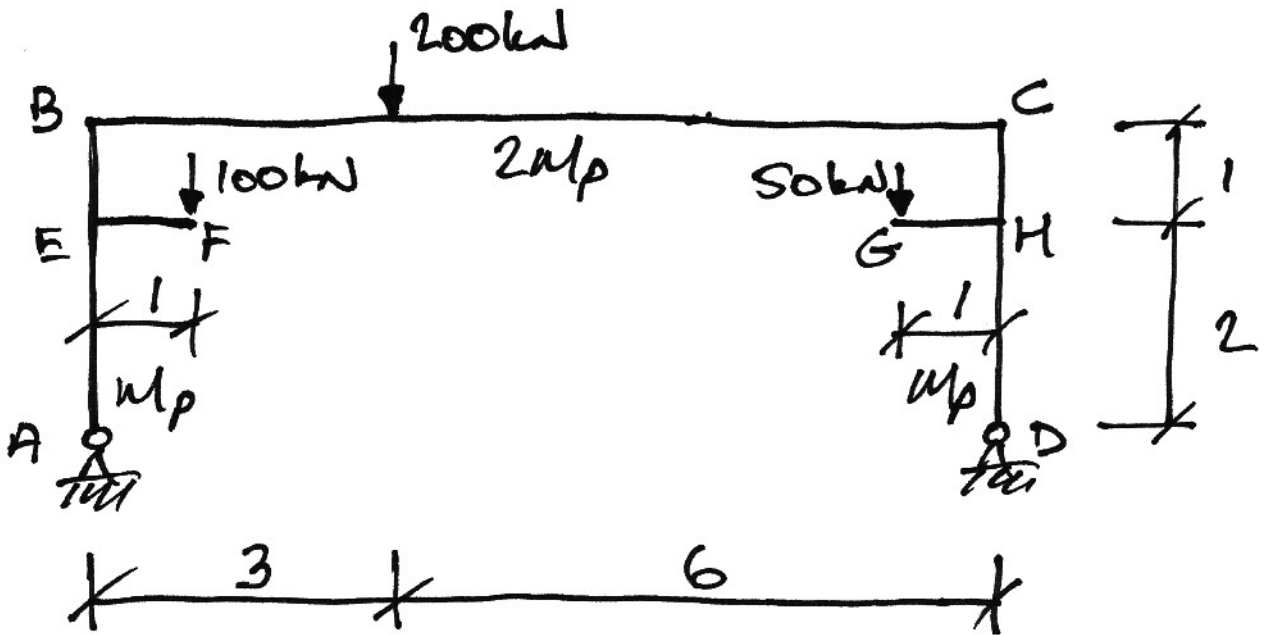

The structure is 1 degree indeterminate so the number of plastic hinges required is 2.

We propose the following collapse mechanism:

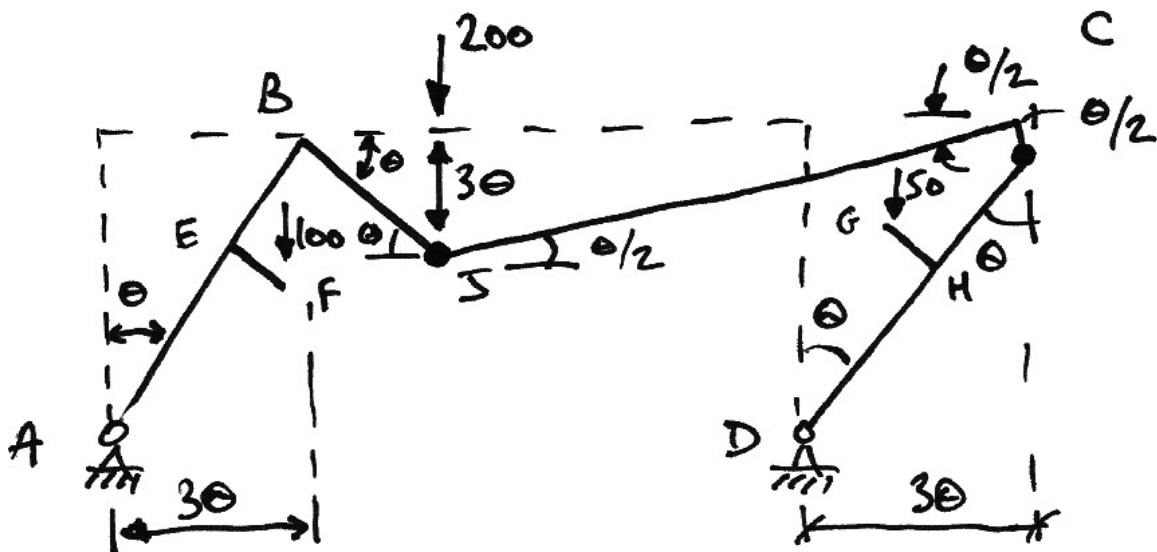

Also, looking closely at the relevant joints:

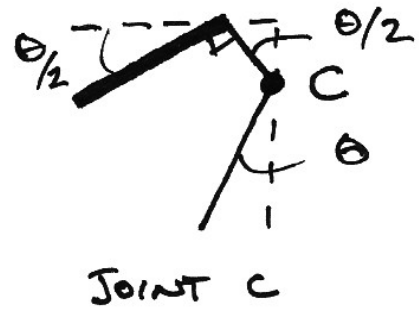
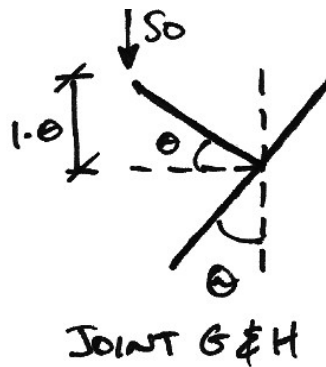
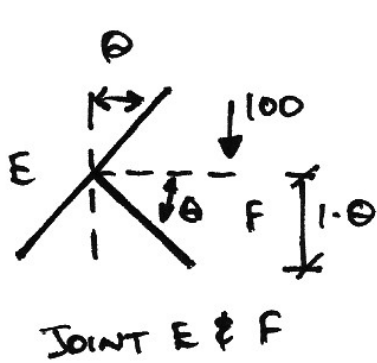

Thus we have:

$$\delta W_e = \delta W_i$$

$$\underbrace{200(3\theta)}_{\text{At J}} + \underbrace{100(\theta)}_{\text{At F}} - \underbrace{50(\theta)}_{\text{At G}} = \underbrace{2M_p\left(\frac{3}{2}\theta\right)}_{\text{At J}} + \underbrace{M_p\left(\frac{3}{2}\theta\right)}_{\text{At C}}$$

$$650\theta = 4.5M_p\theta$$

$$M_p = 144.44 \text{ kNm}$$

Notice that the 50 kN point load at G does negative external work since it moves against its direction of action.

Note also that there are other mechanisms that could be tried, some of which are unreasonable.

Next we check this solution to see if it is unique:

1. Equilibrium:

For the whole frame, taking moments about D gives:

$$50 \cdot 1 + 200 \cdot 6 + 100 \cdot 8 - 9V_A = 0 \quad \therefore V_A = 227.8 \text{ kN}$$

Using a free body diagram of ABJ , and taking moments about the plastic hinge at J :

$$2 \cdot 144.4 + 100 \cdot 2 - 3 \cdot 227.8 - 3H_A = 0 \quad \therefore H_A = 64.9 \text{ kN}$$

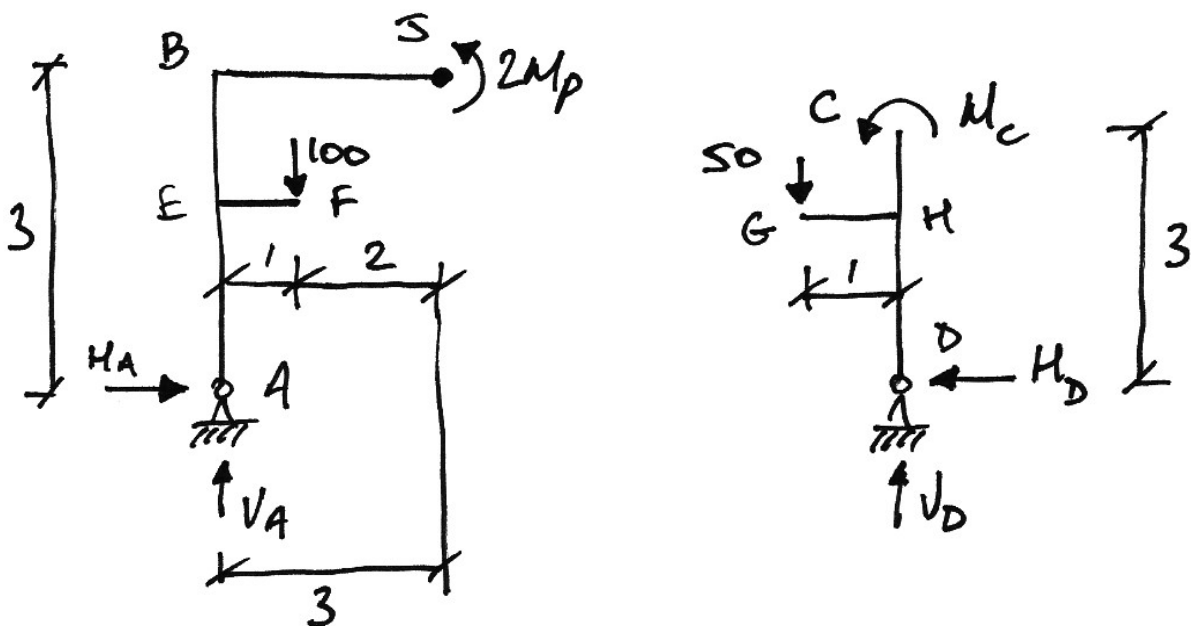

So for the whole frame:

$$\sum F_x = 0 \quad \therefore H_A - H_D = 0 \quad \therefore H_D = 64.9 \text{ kN}$$

Thus for the free body diagram of CD , taking moments about C :

$$M_C - 50 \cdot 1 - 3H_D = 0 \quad \therefore M_C = 144.7 \text{ kNm}$$

Since this is the value of M_p we have a plastic hinge at C as expected. Thus the loads are in equilibrium with the collapse mechanism.

2. Mechanism:

Since $R - C - 3 = 4 - 2 - 3 = -1$ we have a mechanism.

3. Yield:

Drawing the bending moment diagram at collapse shows that no section has a moment greater than its moment capacity of either M_p or $2M_p$:

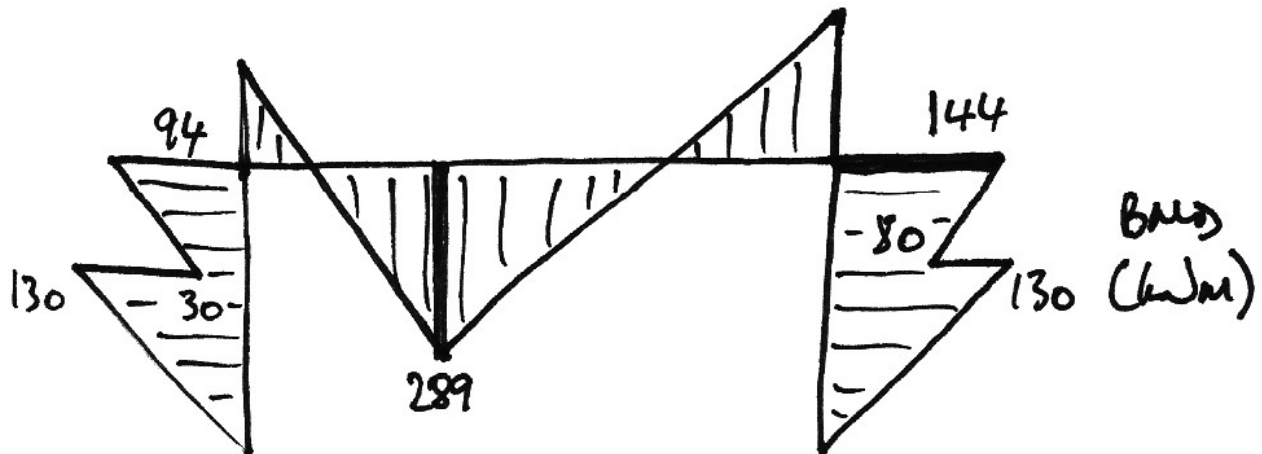

6.4 Example 7 – Oblique Frame, Sumer 1999

Problem

The following rigid-jointed frame is loaded with working loads as shown:

1. Find the value of the collapse load factor when $M_p = 120$ kNm;
2. Show that your solution is the unique solution;
3. Sketch the bending moment diagram at collapse, showing all important values.

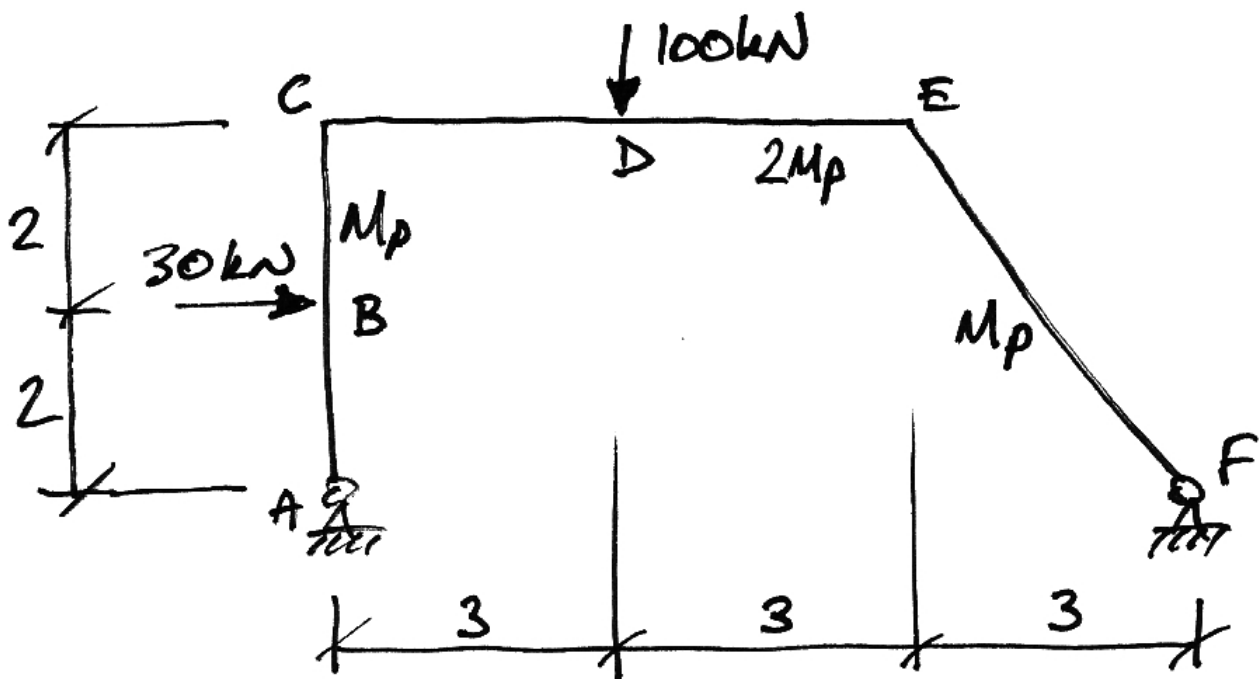

Solution

To solve this problem, first we will consider the basic mechanisms of collapse. Examining these, we will then use Combination of Mechanisms to find a mechanism (or more) that attempts to maximize external work and minimize internal work. We will then verify our solution using the Uniqueness Theorem.

Beam Collapse Mechanisms:

There are two possible beam collapse mechanisms, where local collapse of a member forms due to the point loads acting on that member. Thus we must consider beam collapses of the column *AC* and the beam *CE*.

Beam Collapse of Member *CE*

The mechanism is:

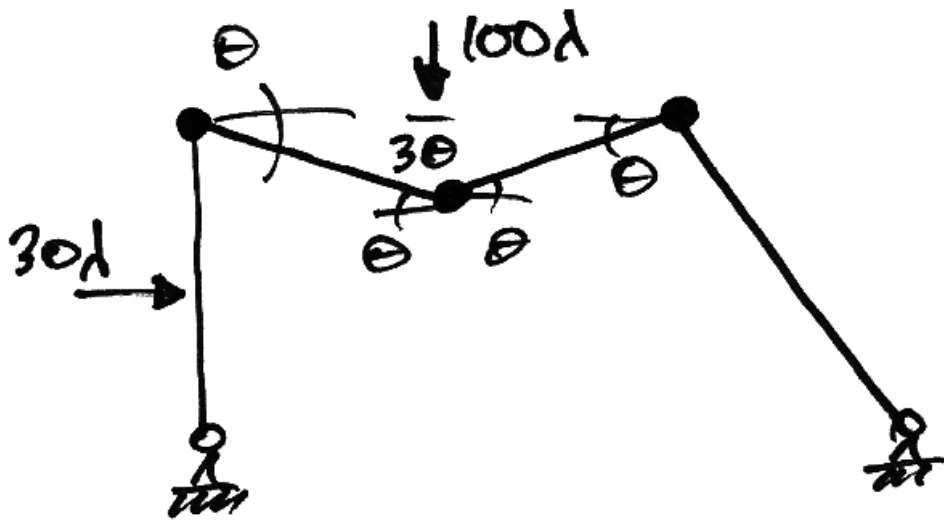

And so the virtual work done is:

$$\begin{aligned} \delta W_e &= \delta W_i \\ 100\lambda(3\theta) &= M_p\theta + 2M_p(2\theta) + M_p\theta \\ 300\lambda\theta &= 6M_p\theta \\ \lambda &= 2.4 \end{aligned}$$

Since $M_p = 120$ kNm.

Beam Collapse of Member AC

The mechanism is:

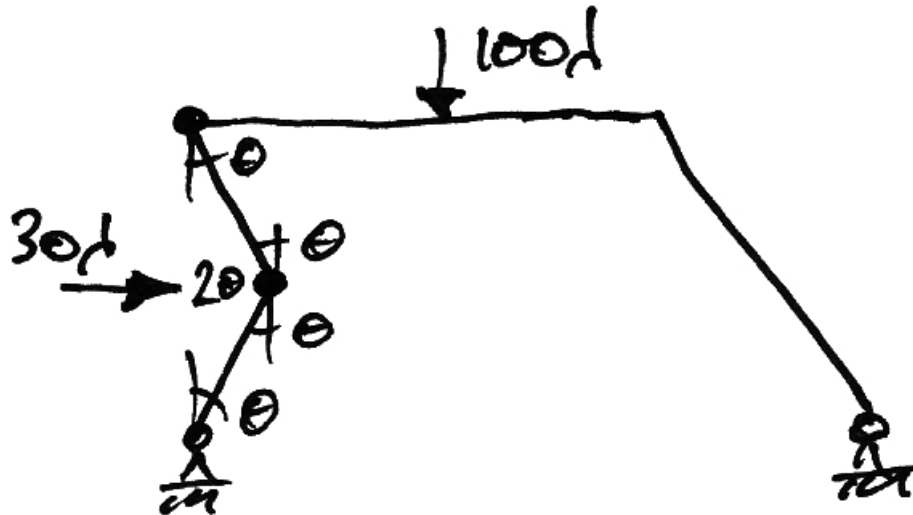

And so the virtual work done is:

$$\begin{aligned}\delta W_e &= \delta W_i \\ 30\lambda(3\theta) &= M_p(2\theta) + M_p\theta \\ 90\lambda\theta &= 3M_p\theta \\ \lambda &= 4.0\end{aligned}$$

Sway Collapses:

The frame could collapse to the right under the action of the horizontal load. However, it could also have a sway collapse to the left, as the inclined member tends to rotate downwards. Thus we consider two possible sway collapse mechanisms.

Sway Collapse to the Right:

The mechanism is:

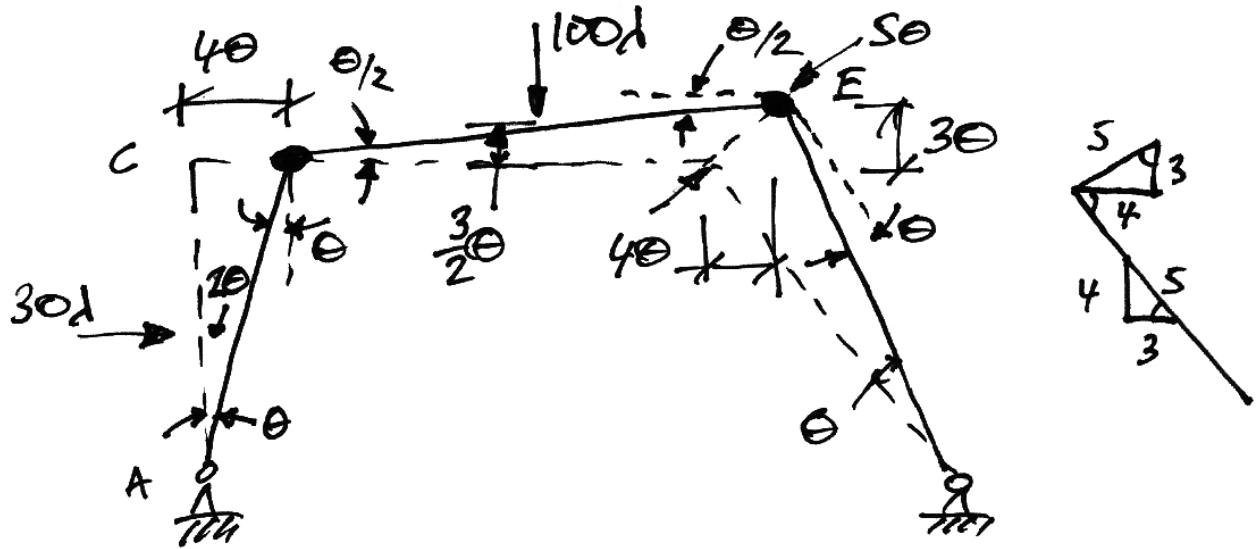

The joints require particular attention:

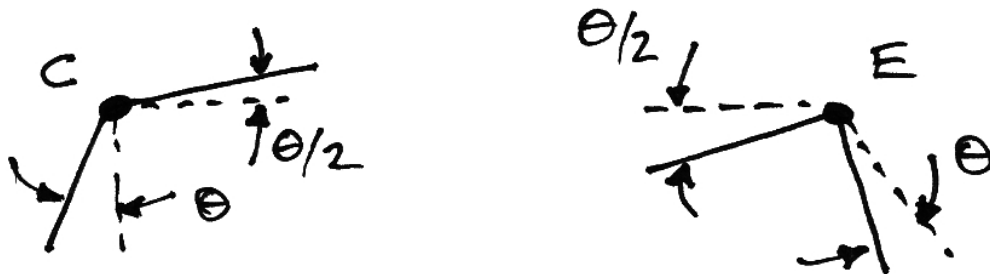

And so the virtual work done is:

$$\delta W_e = \delta W_i$$

$$30\lambda(2\theta) - 100\lambda\left(\frac{3}{2}\theta\right) = M_p\left(\theta + \frac{\theta}{2}\right) + M_p\left(\frac{\theta}{2} + \theta\right)$$

$$-90\lambda\theta = 3M_p\theta$$

As can be seen the net amount of external work is not positive and thus energy needs to be provided to this system in order to get it to fail in this manner. Thus it is not a physically possible failure. However, we can still use some of the analysis later on in a Combination of Mechanisms analysis.

Lastly, the geometry of this mechanism can be awkward. But as we have seen before, analysis of sway movements can often be simplified with the Instantaneous Centre of Rotation concept. Applying it here gives:

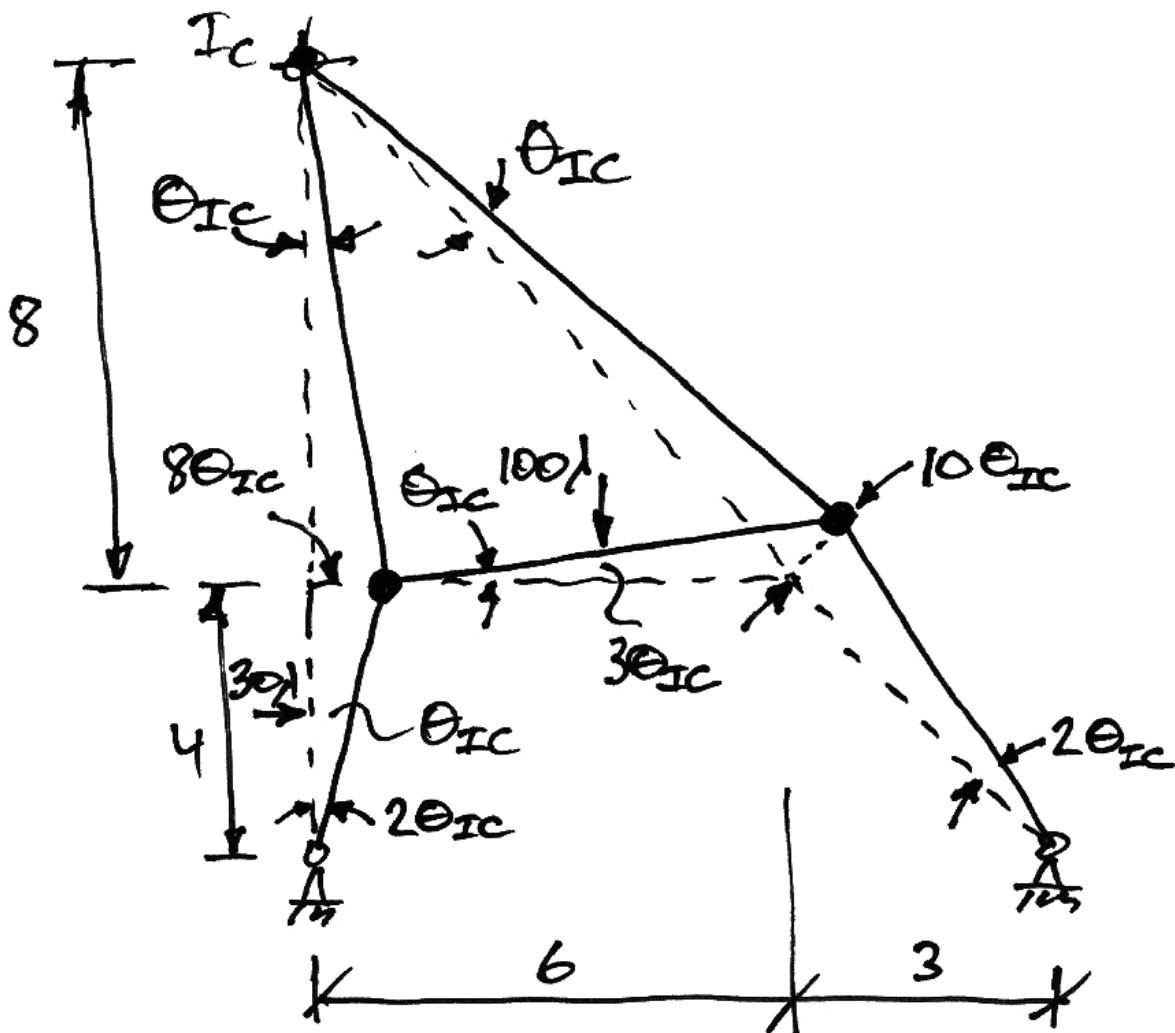

These movements are in the same proportion as before, as expected.

Sway Collapse to the Left

The mechanism is:

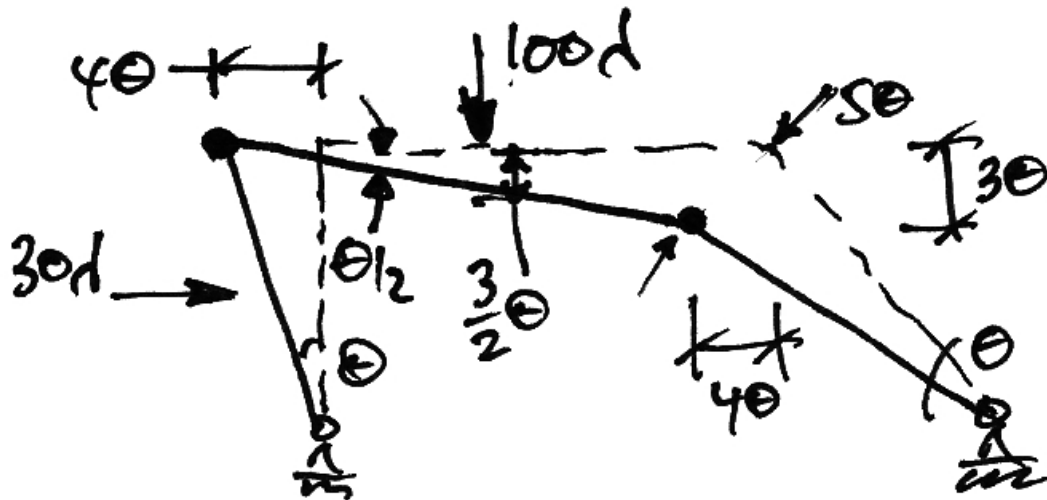

The virtual work done is:

$$\begin{aligned} \delta W_e &= \delta W_i \\ -30\lambda(2\theta) + 100\lambda\left(\frac{3}{2}\theta\right) &= M_p\left(\theta + \frac{\theta}{2}\right) + M_p\left(\frac{\theta}{2} + \theta\right) \\ 90\lambda\theta &= 3M_p\theta \\ \lambda &= 4.0 \end{aligned}$$

Combined Collapse Mechanisms:

There are two more obvious combined collapse mechanisms, both with a beam collapse of the horizontal member, one with sway to the left and the other with sway to the right. From the previous analysis, and since we want to maximize external virtual work, we should check the case where the frame sways to the left first.

Combined Collapse Mechanism

Keeping the sway collapse hinge at C , and allowing the formation of a hinge under the 100 kN point load (thus increasing its external virtual work), and removing the sway collapse hinge at E (since we only need two hinges) we have:

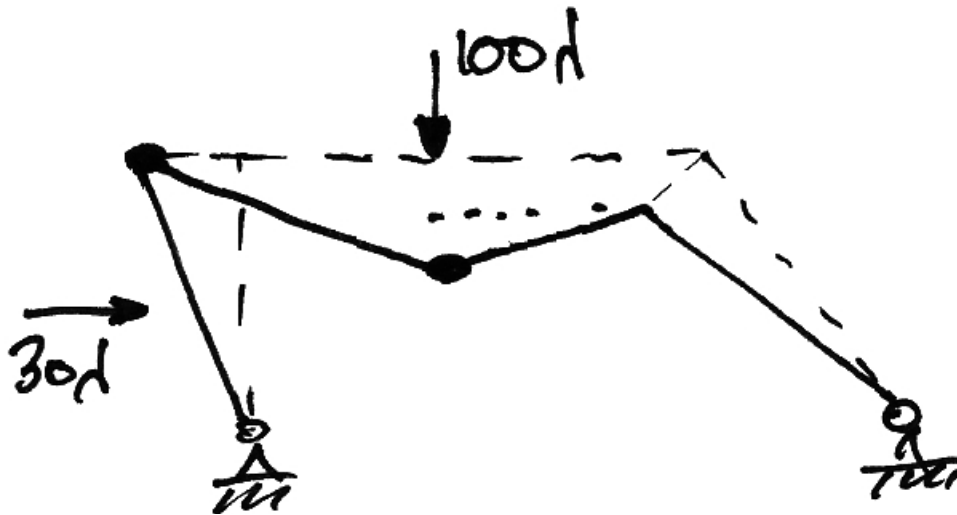

Since we can use our previous results (Combination of Mechanisms), we do not have to work out the geometry of the problem. For external work, we have:

$$\begin{aligned} \delta W_e &= -30\lambda(2\theta) + 100\lambda\left(\frac{3}{2}\theta\right) && \text{(From sway collapse)} \\ &+ 100\lambda(3\theta) && \text{(From beam collapse)} \\ &= 390\lambda\theta \end{aligned}$$

And for internal virtual work:

$$\begin{aligned} \delta W_i &= 3M_p\theta + 6M_p\theta && \text{(From sway and beam collapse)} \\ &- M_p\left(\frac{\theta}{2} + \theta\right) && \text{(Remove sway hinge at } E) \\ &- M_p\theta && \text{(Remove beam hinge at } E) \\ &= 6.5M_p\theta \end{aligned}$$

Thus we have:

$$\begin{aligned}\delta W_e &= \delta W_i \\ 390\lambda\theta &= 6.5M_p\theta \\ \lambda &= 2.0\end{aligned}$$

We can check this result using the usual approach:

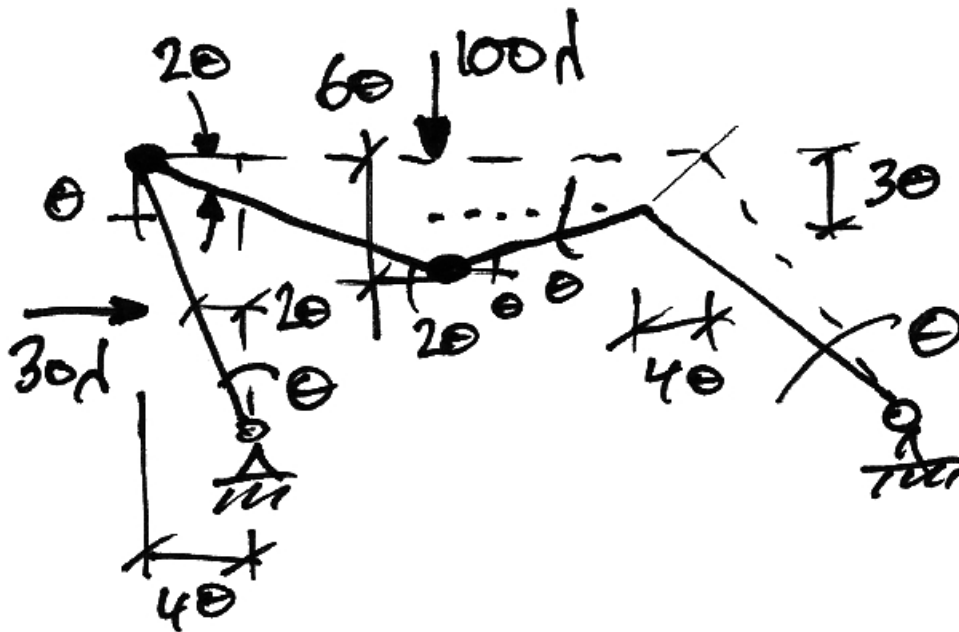

$$\begin{aligned}\delta W_e &= \delta W_i \\ -30\lambda(2\theta) + 100\lambda(6\theta) &= M_p(\theta + 2\theta) + 2M_p(2\theta + \theta) \\ 540\lambda\theta &= 9M_p\theta \\ \lambda &= 2.0\end{aligned}$$

And as expected we get the same result.

Since this is a likely candidate mechanism, check this using the Uniqueness Theorem.

Check with Uniqueness Theorem

1. Equilibrium:

To check equilibrium, we will determine the reactions and then the moments at salient points. Thus the bending moments diagram can be drawn, providing the check that the external loads are in equilibrium with the internal moments, and that yield is nowhere violated.

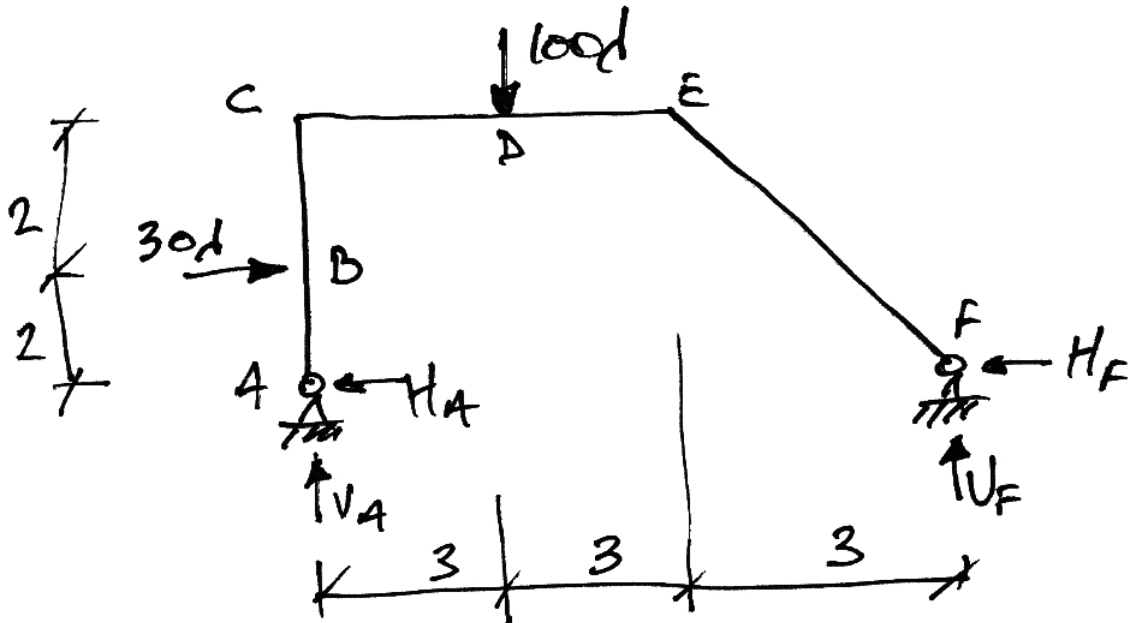

For the whole frame, taking moments about A gives:

$$30\lambda \cdot 2 + 100\lambda \cdot 3 - 9V_F = 0 \quad \therefore V_F = 40\lambda \text{ kN}$$

Next, summing vertical forces gives:

$$100\lambda - V_F - V_A = 0 \quad \therefore V_A = 60\lambda \text{ kN}$$

Using the free body diagram of ABC, taking moments about C:

$$M_C - 30\lambda \cdot 2 + 4H_A = 0 \quad \therefore H_A = 0 \text{ kN}$$

Where we have the fact that the moment at C is the plastic moment capacity, i.e. $M_C = M_p = 120 \text{ kNm}$, and $\lambda = 2$.

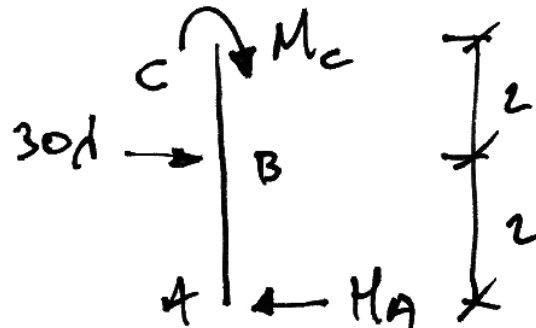

So for the whole frame, we have:

$$\sum F_x = 0 \quad \therefore 30\lambda - H_A - H_F = 0 \quad \therefore H_F = 30\lambda \text{ kN}$$

Thus all the reactions have been determined. Next we determine the moments at important points:

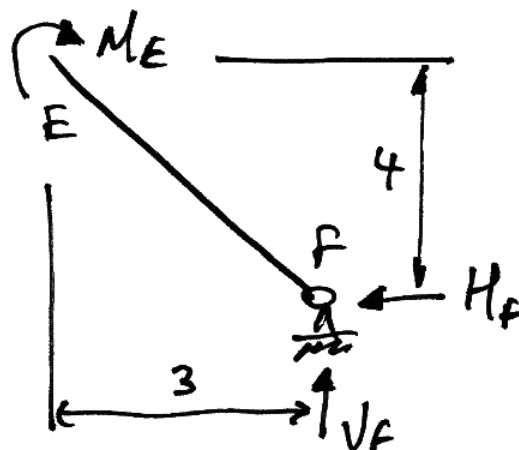

For the free body diagram of EF , taking moments about E :

$$M_E + 4H_F - 3V_F = 0$$

$$M_E + 4(30\lambda) - 3(40\lambda) = 0$$

$$M_E = 0$$

For the free body diagram of DEF , taking moments about D gives:

$$M_D + 4H_F - 6V_F = 0$$

$$M_E + 4(30\lambda) - 6(40\lambda) = 0$$

$$M_E = 120\lambda \text{ kNm}$$

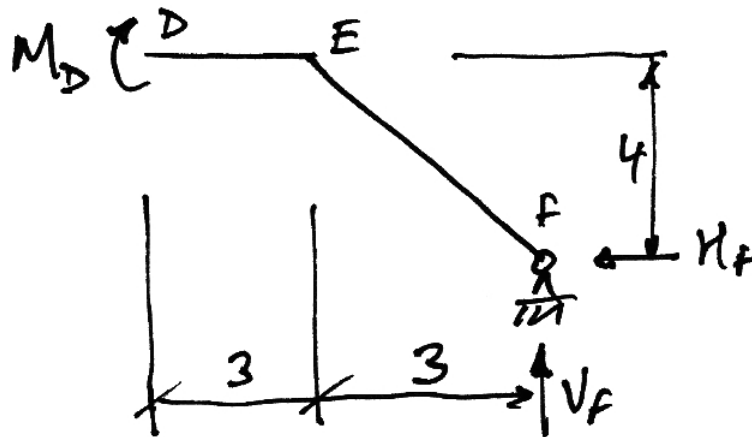

Thus we can draw the bending moment diagram, verifying equilibrium:

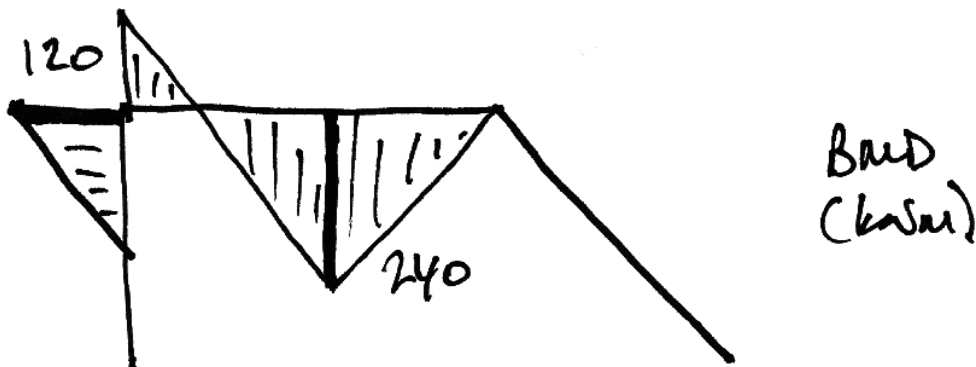

2. *Mechanism:*

Since $R - C - 3 = 4 - 2 - 3 = -1$ we have a mechanism.

3. *Yield:*

The bending moment diagram at collapse shows that no section has a moment greater than its moment capacity of either M_p or $2M_p$:

Thus the requirements of the Uniqueness Theorem have been met, and so the collapse load factor of $\lambda = 2$ is the correct value.

7. Past Exam Questions

7.1 Sumer 2000

The following rigid-jointed frame shown below is loaded with working loads as shown:

1. Find the value of the collapse load factor when $M_p = 120$ kNm;
2. Show that your solution is the unique solution;
3. Sketch the bending moment diagram at collapse, showing all important values.

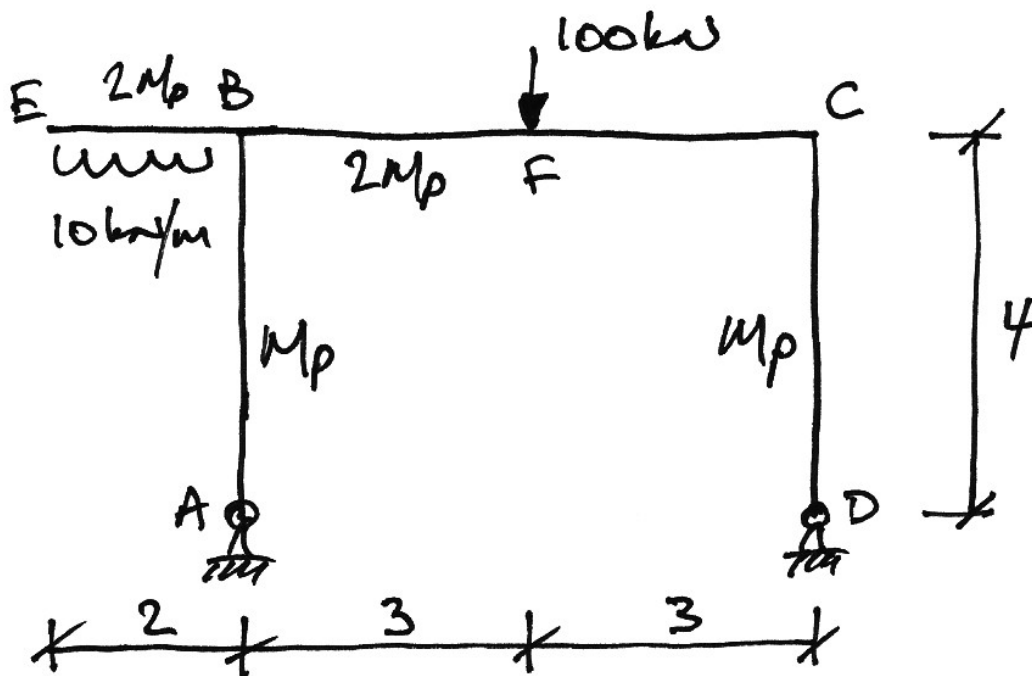

(Ans. $\lambda_c = 2.25$)

7.2 Summer 2001

The following rigid-jointed frame is loaded with working loads as shown:

4. Find the value of the collapse load factor when $M_p = 120 \text{ kNm}$;
5. Show that your solution is the unique solution;
6. Sketch the bending moment diagram at collapse, showing all important values.

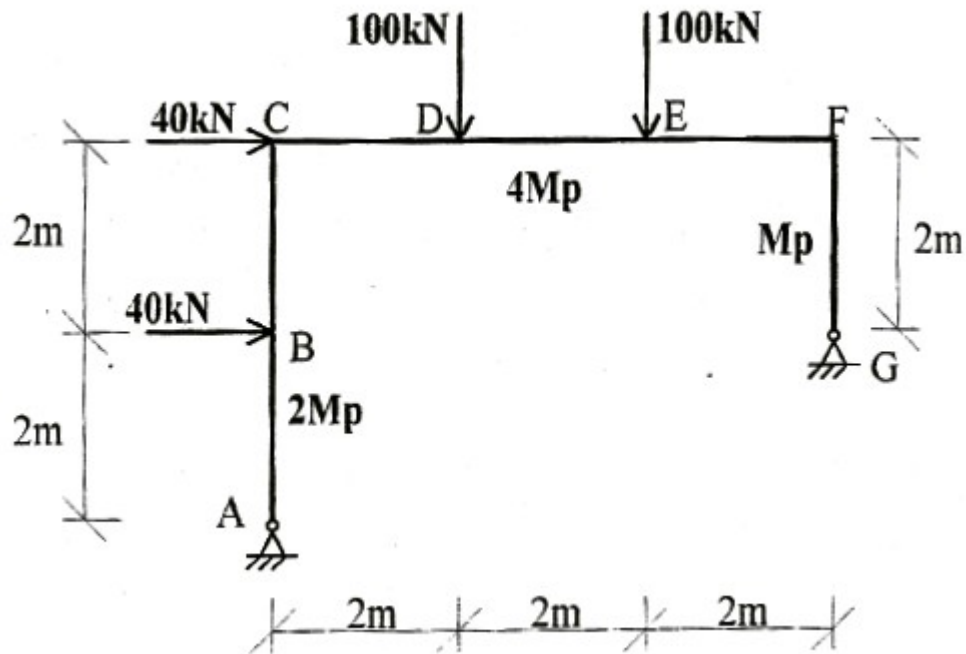

(Ans. $\lambda_c = 1.89$)

7.3 Summer 2004

The following rigid-jointed frame is loaded with working loads as shown:

1. Find the value of the collapse load factor when $M_p = 160 \text{ kNm}$;
2. Show that your solution is the unique solution;
3. Sketch the bending moment diagram at collapse, showing all important values.

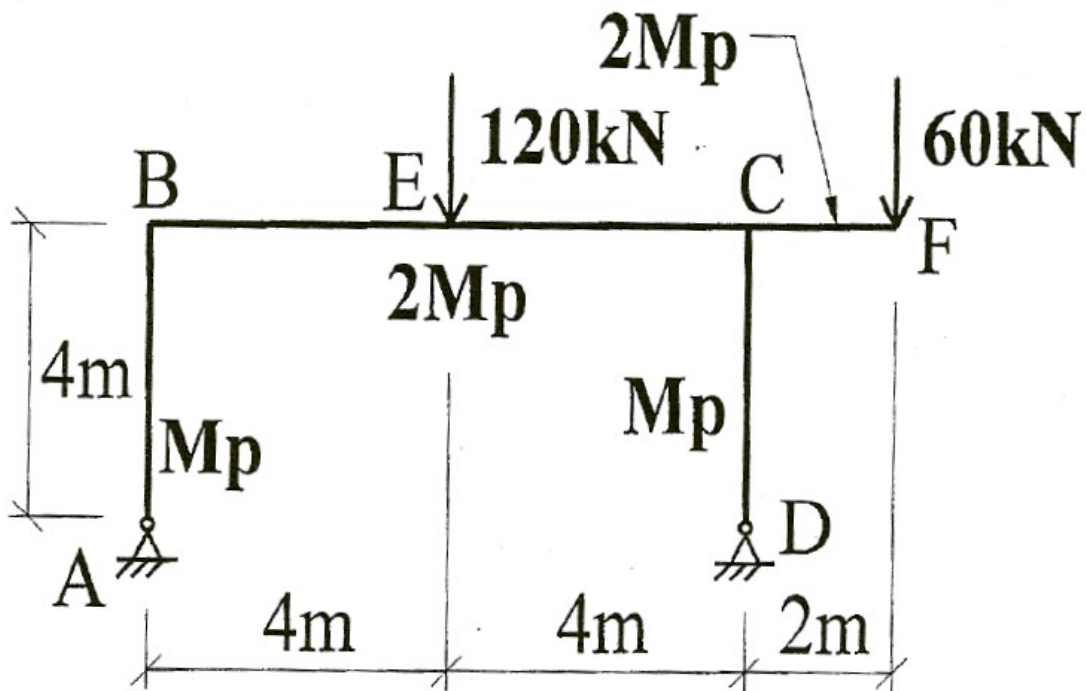

(Ans. $\lambda_c = 2.13$)

7.4 Summer 2005

The following rigid-jointed frame is loaded with working loads as shown:

1. Find the value of the collapse load factor when $M_p = 200 \text{ kNm}$;
2. Show that your solution is the unique solution;
3. Sketch the bending moment diagram at collapse, showing all important values.

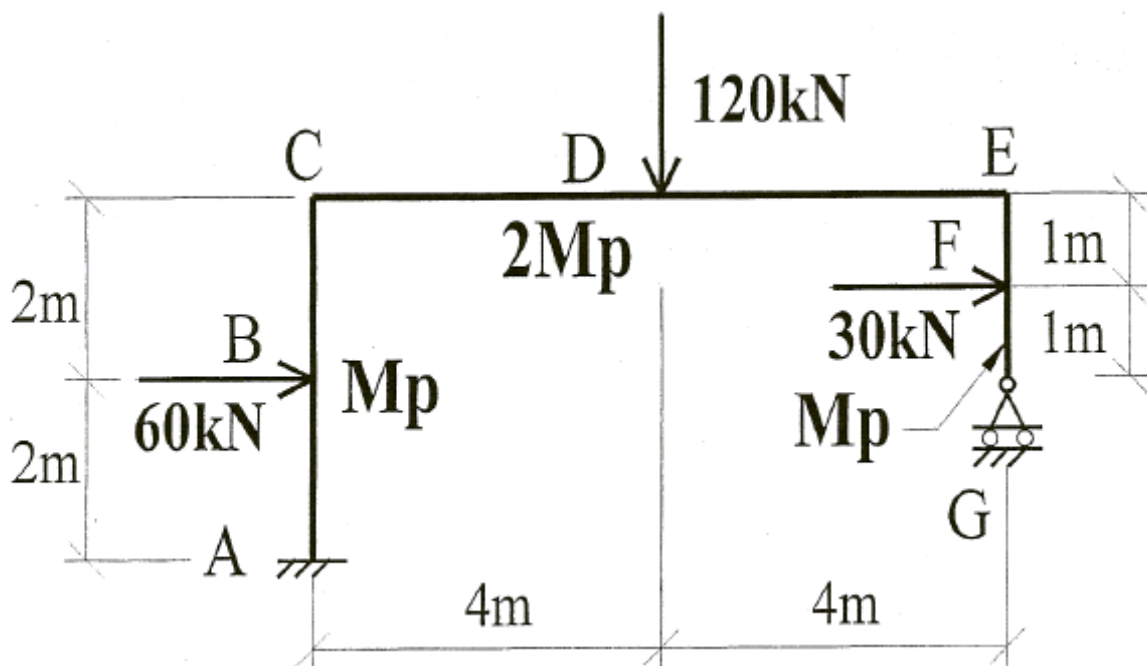

(Ans. $\lambda_c = 1.33$)

7.5 Summer 2007

The following rigid-jointed frame is loaded so that the force system shown is just sufficient to cause collapse in the main frame ABCD:

1. Find the value of M_p given that the relative plastic moment capacities are as shown in the figure;
2. Show that your solution is the unique solution;
3. Sketch the bending moment diagram at collapse, showing all important values.

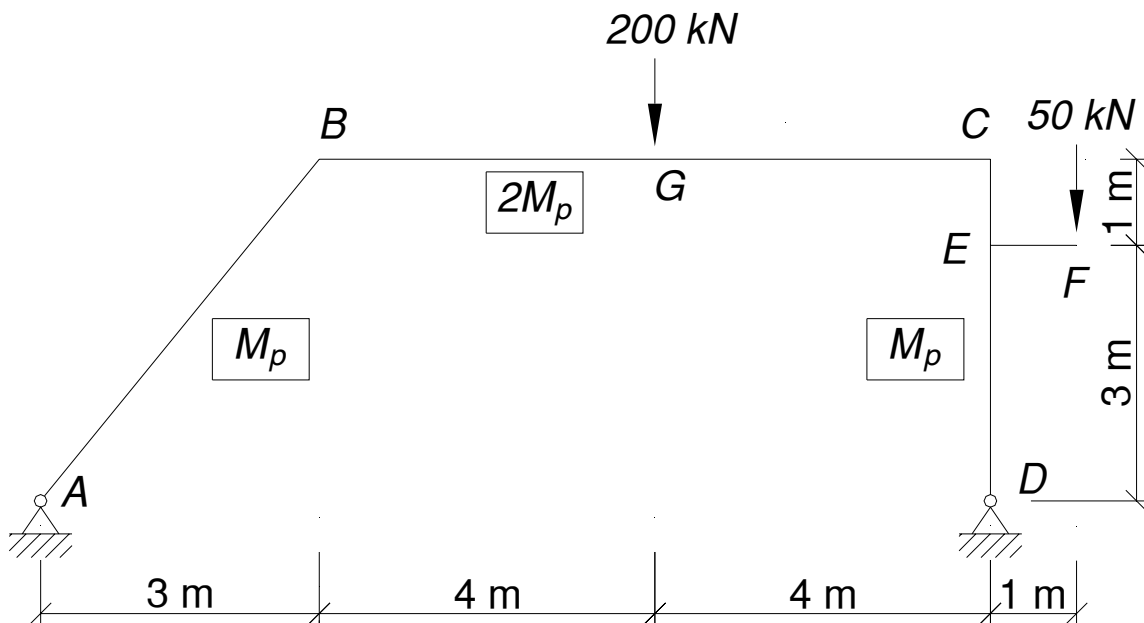

(Ans. $M_p = 175.8$ kNm)

7.6 Semester 2 2008

For the following rigid-jointed frame, loaded with the working loads shown, do the following:

1. Find the load factor which causes collapse of the frame, given that $M_p = 80 \text{ kNm}$;
2. Show that your solution is the unique solution;
3. Sketch the bending moment diagram at collapse, showing all important values.

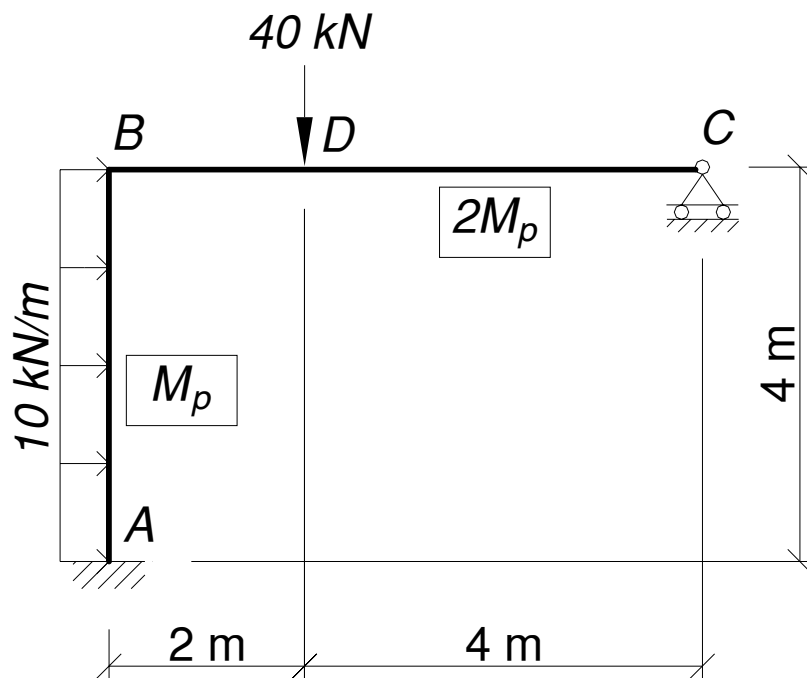

(Ans. $\lambda_c = 2.0$)

7.7 Semester 2 2009

QUESTION 4

For the rigid-jointed frame of Fig. Q4, loaded with the working loads shown, do the following:

- (i) For a collapse load factor of 1.2, determine the design plastic moment capacity, M_p ;
- (ii) Show that your solution is the unique solution;
- (iii) Sketch the bending moment diagram at collapse, showing all important values;
- (iv) Briefly comment on how the uniqueness theorem relates to your solution.

(25 marks)

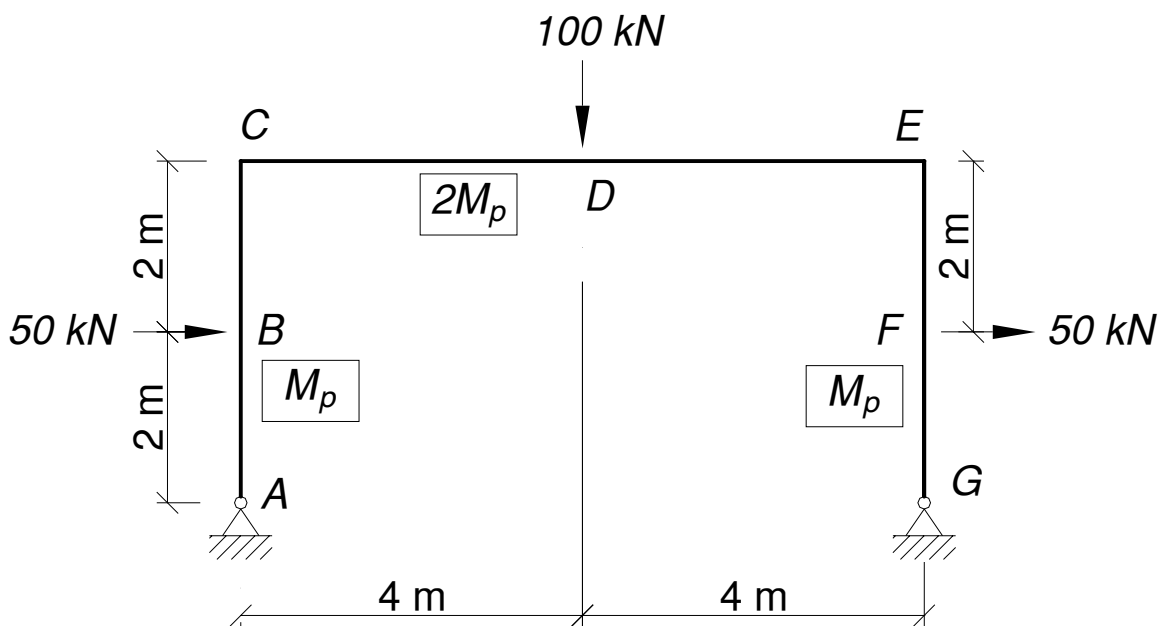

FIG. Q4

(Ans. $M_p = 120 \text{ kNm}$)

8. References

- Baker, J.F., Horne, M.R. and Heyman, J., *The Steel Skeleton, Volume II, Plastic Behaviour and Design*, Cambridge University Press, 1956.
- Baker, J.F. and Heyman, J., *Plastic Design of Frames, Vol. 1: Fundamentals*, Cambridge University Press, London, 1969.
- Bruneau, M., Uang, C.M. and Whittaker, A., *Ductile Design of Steel Structures*, McGraw-Hill, New York, 1998.
- Davies, J.M. and Brown, B.A., *Plastic Design to BS5950*, Blackwell Science, Oxford, 1996.
- Heyman, J., *Plastic Design of Portal Frames*, Cambridge University Press, London, 1957.
- Heyman, J., *Plastic Design of Frames, Vol. 2: Applications*, Cambridge University Press, London, 1971.
- Heyman, J., *Beams and Framed Structures*, 2nd Edn., Pergamon Press, 1974.
- Heyman, J., *Elements of the Theory of Structures*, Cambridge University Press, 1996.
- Hodge, P.G., *Plastic Analysis of Structures*, McGraw-Hill, New York, 1959.
- McKenzie, W.M.C., *Examples in Structural Analysis*, Taylor and Francis, Abington, 2006.
- Neal, B.G., *Structural Theorems and their Applications*, Pergamon Press, 1964.
- Neal, B.G., *The Plastic Methods of Structural Analysis*, 3rd Edn., Chapman & Hall, London, 1977.
- Thompson, F., and Haywood, G.G., *Structural Analysis Using Virtual Work*, Chapman and Hall, 1986.
- Rees, D.W.A., *Mechanics of Solids and Structures*, Imperial College Press, London, 2000.
- Wong, M.B., *Plastic Analysis and Design of Steel Structures*, Butterworth-Heinemann, London, 2009.