

# An Enhanced AODV Routing Protocol for Wireless Sensor and Actuator Networks

Apidet Booranawong, Wiklom Teerapabkajorndet

**Abstract**—An enhanced ad-hoc on-demand distance vector routing (E-AODV) protocol for control system applications in wireless sensor and actuator networks (WSANs) is proposed. Our routing algorithm is designed by considering both wireless network communication and the control system aspects. Control system error and network delay are the main selection criteria in our routing protocol. The control and communication performance is evaluated on multi-hop IEEE 802.15.4 networks for building-temperature control systems. The Gilbert-Elliott error model is employed to simulate packet loss in wireless networks. The simulation results demonstrate that the E-AODV routing approach can significantly improve the communication performance better than an original AODV routing under various packet loss rates. However, the control performance result by our approach is not much improved compared with the AODV routing solution.

**Keywords**—WSANs, building temperature control, AODV routing protocol, control system error, settling time, delay, delivery ratio.

## I. INTRODUCTION

IN WSANs, sensor nodes periodically measure controllable conditions of a physical system and transmit these samples to a controller via wireless multihop communication networks [1], [2]. The difference between the sensed value and the desired level determines a control signal for directing a proper amount of a manipulated variable that an actuator should apply on a plant to adjust the system condition [3], [4]. Accordingly, sensing information must be transmitted reliably over the multihop networks in order to perform the control operations accurately at the actuator. Routing is a mechanism of finding a route for multihop communications from a source node originating sensory-data packets to a destination node connecting to a controller and actuator. Typically, unreliable wireless communications can cause packet drops and variation of packet transmission delay [5]. In WSANs, a large number of consecutive packet drops at the destination can impair control performance significantly [3]. Routing can play a very important role to reduce the chance of this degrading control performance by choosing an appropriate transmission path. How to design such a routing algorithm to satisfy both communication and control performance in WSANs is the research problem investigated in this paper.

Although there are some research works related to WSAN routing algorithms in the literature, most of them still do not consider joint operations among control systems and wireless networks. References [6]-[15] propose routing protocols for

WSANs. However, the research methodologies of these studies are still the same as approaches in traditional wireless sensor networks. Additionally, they are only interested in the wireless communication aspect for developing routing algorithms. They do not consider the functions of controllers, actuators, and physical systems; actuators cannot response any actions to change the behavior of environments. Hence, the effect of routing algorithms to the resulting control output cannot be evaluated, and how these proposed methods can be applied for control applications is still a research question. In [16], an adaptable communication protocol for minimizing energy consumption in wireless sensor networks is presented. The optimization constraints are reliability and latency thresholds based on control application requirements. The reliability is defined by the probability of successfully received packet at the sink node, and the latency is described by the probability of the largest end-to-end delay less than the threshold. These two thresholds are set greater than 0.90 for the performance evaluation. However, this latest work completely ignores the functions of controllers, actuators, and plants in the evaluation.

Reference [2] presents the simulation case studies of wireless networked control systems. The considered control applications are the building automation and the target tracking. The main objective of the study is to develop and test the integrated communication and control systems by the simulation approach. Both wireless network protocols and control system functions are provided in the study. Moreover, the performance studies of the routing algorithms are explored in both control scenarios. However, any performance in terms of the control perspective affected by wireless network communications is not presented. Reference [4] explores centralized and distributed control techniques in WSANs for the building temperature control by the simulation study. Both control functions and wireless networking are developed for the exploration. The wireless communication protocols employ the geographical and energy aware routing and an IEEE 802.15.4 protocols. The control system error as the deferent between the desired target and the measured temperature value is recorded for the evaluation. However, the work in [4] only focuses on the designing of control system strategies to achieve control objectives. The investigation of how the routing algorithm influences the control system output is out of the scope of the study.

To fill the missing knowledge gap as discussed in the literature, this paper proposes a routing algorithm as the joint design algorithm between wireless communication and control perspectives for WSAN control applications. To satisfy both wireless communication and control performance is the main purpose of our design. The novelty of our routing algorithm is

Apidet Booranawong and Wiklom Teerapabkajorndet are with the Department of Electrical Engineering, Faculty of Engineering, Prince of Songkla University, Hat-yai, Songkhla, 90112 Thailand (e-mail: apidet.boo@gmail.com, wiklom.t@psu.ac.th).

that it finds a route for data transmission by taking the control system error indicating the control system states and the packet transmission latency over a wireless link into account. Thus, both wireless network communication and control aspects are considered. For the performance evaluation, the building temperature control system scenario is employed as the considered control application, and the wireless network is based on the IEEE 802.15.4 standard. A packet loss model representing indoor environments is modeled by the Gilbert-Elliott error model. For building automation applications [2]-[4], WSANs can be used to control and maintain the temperature inside the building. Sensor nodes collect the zone temperature and send their sensing data to controllers. Controllers/actuators perform their actions by feeding the appropriate supply air temperature into the building. This mechanism continues until the zone temperature reaches the desired level. The finding shows that the control system performance directly depends on the routing mechanism. When considering the network performance, the proposed routing algorithm is better than the AODV routing under various packet loss rates. However, the control performance results of both routing schemes are not statistically different.

The rest of this paper is organized as follows. Section II presents the proposed routing algorithm. Section III develops the WSAN control system model. Section IV describes the simulation setup including the simulation scenario, the packet loss model, and the performance metric. Section V provides the simulation results and discussions. Finally, Section VI concludes this paper.

## II. ENHANCED AODV ROUTING PROTOCOL FOR CONTROL APPLICATIONS

Before explaining our proposed routing solution, the traditional AODV routing as the reference method of the proposed solution is introduced here. The AODV routing initially finds a route by employing route request (RREQ) and route reply (RREP) messages; the minimum hop-count route that the RREQ and the RREP messages can travel in the networks is selected for data transmission. In the AODV routing, when the source node has to transmit its sensing data to the sink node for which it has no routing information in its routing table, it begins a route establishment procedure by broadcasting the RREQ message to all of its neighbor nodes. The neighbor nodes as the relay nodes receiving the first RREQ continuously forward this message until the RREQ reaches the sink node. In response to the first arrived RREQ message, the sink node confirms the route by returning the RREP message back to the source node. After the source node completely receives the RREP message, it immediately delivers its sensing data along the RREP path.

### A. Design Concepts

In the proposed routing algorithm, the source node locating in the physical system selects a route for data transmission based on the considered control system states; transient and steady states. If the physical system to be controlled is in the transient state, the source node selects a route which has the

minimum delay cost compared with other candidate routes. Otherwise, our proposed routing algorithm follows the same approach as the AODV procedure. The transient state of the control system from the classical control theory is commonly defined by the control system error larger than  $\pm 0.02$  [17], and the control system error is the different level between the predefined control target and the actual sensing level from the physical system. By selecting a route with the smallest delay cost among all candidate routes during the transient state of the control system, the proposed solution can automatically avoid choosing any routes with high traffic load, packet collisions, and packet retransmissions. Note that on the route with high delay cost, both routing and data messages in buffers will wait for a long period of time before they are sent; this is due to the effects of the high traffic load, packet collisions, and retransmissions presented on that route. By the proposed technique, our solution can directly help to reduce the possibility of the packet collisions occurred in the selected routes as well as the failure of route-establishment procedure. As a result, numbers of successful received packets at the sink node are increased, and the control system can reach its steady state fast.

### B. Routing Operations

How the proposed routing algorithm is performed according the design concept as presented above is described here. In the RREQ propagation process, our solution follows the same as the AODV approach. We slightly modify the RREQ process only at the sink node; the sink node can receive duplicate RREQ messages if the hop-count value carried in the RREQ message less than or equal to the previous hop-count value as registered in its routing table. By this technique, multiple candidate routes are provided for the RREP process. In the RREP propagation process, the sink node returns the RREP message back to the source via all multiple candidate routes that the RREQ coming by using the unicast approach. When a relay node receives the RREP message from its neighbor, the delay cost among them is calculated according to an Algorithm 1. The delay cost at any connected link ( $Delay\_Cost_i$ ) in any route is defined by the time difference between the current time at the receiving node ( $Current\_Time$ ) and the RREP sending time by the source node ( $Time\_Stamp$ ). It is normalized by the hop-count value ( $Hop\_Count$ ) which is carried in the RREP message. For any candidate route, the relay node records only the maximum value of the delay cost into the receiving RREP message by selecting the higher value between the delay cost determined by itself and the previous maximum delay cost as registered in the receiving RREP message. The maximum delay cost from any connected link in the route indicates the weakness of that route.

---

**ALGORITHM 1:** RREP received function at relay nodes

---

VARIABLES:  $Delay\_Cost_i$ ,  $Current\_Time$ ,  $Time\_Stamp$ ,  $Hop\_Count$   
BEGIN  
1.  $Delay\_Cost_i = (Current\_Time - Time\_Stamp) / Hop\_Count$   
2. Records only the maximum value of  $Delay\_Cost_i$  into the RREP message  
END

---

**ALGORITHM 2:** RREP received function at the source node

```

VARIABLES: Control_System_Error, Designed_Value,
Measured_Value, Delay_Cost
BEGIN
1. Control_System_Error = |Desired_Value - Measured_Value|
2. IF (Control_System_Error ≥ 0.02) THEN
3.   Selects the route with the smaller value of the maximum Delay_Costi
   for data transmission
4. END IF
END
    
```

The routing operation by the source node is presented in an Algorithm 2. When the source node receives the first RREP message, it instantly sends its sensing data to the sink node along the path that the first RREP coming. If other RREP messages from other paths are received by the source node, it responses only if the new route has the maximum delay cost extracting from the RREP message less than the maximum delay cost extracting from the previous RREP messages as registered in its routing table. Consequently, the route with minimum value of the maximum delay cost is chosen for data transmission. This mechanism is performed only under the transient state condition of the considered control system as describes before. The source node locating in the physical system determines the state of the control system by itself. The transient state is defined by the control system error (*Control\_System\_Error*) higher than  $\pm 0.02$ , and the control system error is the different level between the desired value (*Desired\_Value*) and the measured (*Measured\_Value*) value from the physical system.

III. WSN CONTROL SYSTEM MODEL

As mentioned earlier, this work employs a building temperature control as a control application model. The WSN system for the building temperature control is represented in Fig. 1. The objective of this system is to measure and control the temperature in a room via a wireless sensor network. There are three main components in Fig. 1: a controller and an actuator, a plant or a physical model, and a wireless sensor network. The controller is responsible for making control decisions to the heating/cooling actuator based on the measured temperature by a sensing node. The actuator feeds the inflow air with the appropriate temperature into the room. The temperature

behavior in the room is characterized by its physical model. In this scenario, the source node is placed in the room and measures the temperature every predefined sampling period. The sensing value is then encapsulated in a data packet and sent to the sink node via wireless network communications. The controller computes the error between the set point and the measured temperature values before finding a suitable supply air temperature command to the actuator. This wireless feedback control system continues until the temperature in the room converges to the desired target.

In this study, the physical model is the zone temperature model, and the controller is the proportional integral derivative (PID) controller. More explanations about them and their parameters assigned for the simulation can be found in our previous work [18]. To study the routing performance in the WSN control system, we conduct a set of experiments by using the simulation tool, namely PiceSIM [19]. This tool is a joint control and communication simulator. Wireless network communications are simulated by NS2 (Network Simulator 2), while the control system functions including the zone temperature model, the PID controller, and the actuator are simulated by MATLAB/Simulink.

IV. SIMULATION SETUP

A. Simulation Scenario

The simulated WSN scenario for this study is shown in Fig. 2. Node ID 40 is only a sensing source in our scenario. This node measures the zone temperature in the room and transmits its sensing data to the neighbor node every predefined sampling period. The sampling period for this study is set to 10 s [2]. Node ID 0 is a sink node connected to the PID controller and the actuator. We assume that only the source node is located in the room, and the actuator heats the inflow air into the room via the air duct. Locations of all nodes are fixed and the transmission range of a node is not farther than one hop communications. The radio parameters assigned for each node are set according to the CC2420 RF transceiver [20], [21]. The simulation parameters are provided in Table I.

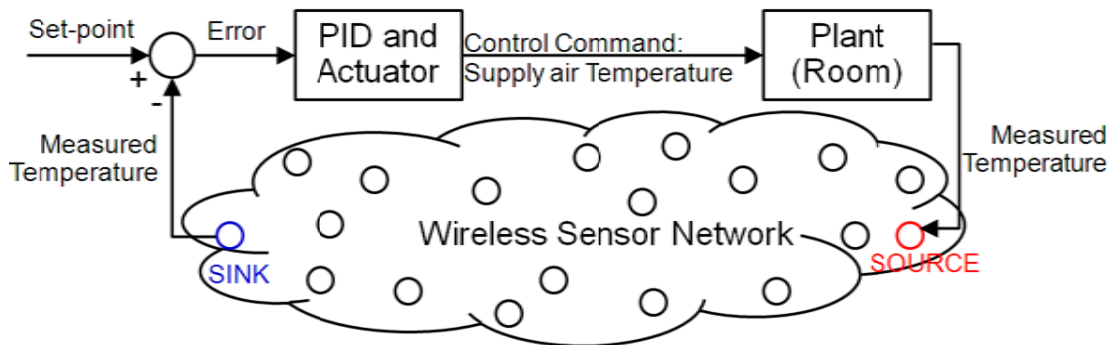

Fig. 1 Building temperature control system

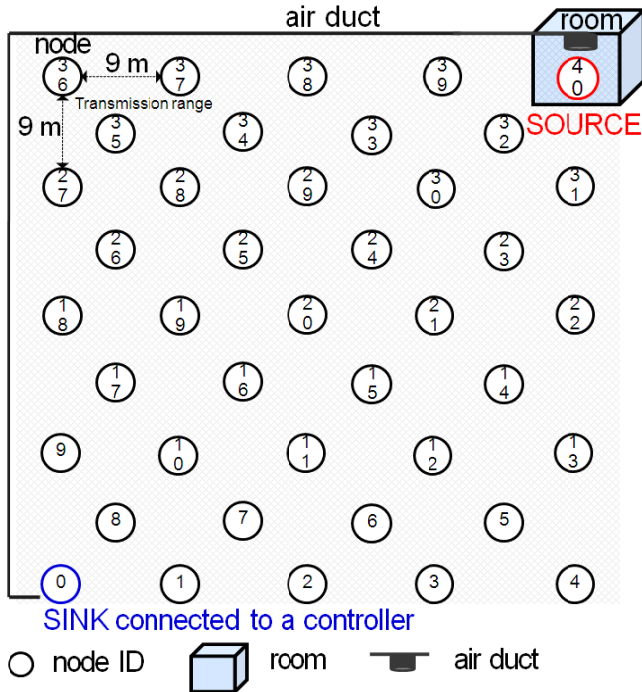

Fig. 2 Simulation scenario

TABLE I  
SIMULATION PARAMETERS

Parameters	Values
Dimension of the topology (m <sup>2</sup> )	70 m * 70 m
Simulation time (s)	1000
Number of nodes	41
Buffer size (packets)	64
Sampling period (s)	10 [2]
Radio propagation model	Two-ray ground
Path loss exponent	3.1 (Indoor) [21]
Frequency (GHz)	2.4
Receiver sensitivity (dBm)	-95 [21]
RXThreshold (W)	3.16228e-13
CSThreshold (W)	3.68817e-14
Maximum transmission range (m)	9.25 m
Transmit power at -25 dBm (W)	0.01530 [21]
Receive power (W)	0.03384 [21]
Idle power (W)	0.0007668 [21]
MAC protocol	IEEE 802.15.4
Routing protocol	AODV
$P_{GG}, P_{GB}, P_{BG},$ and $P_{BB}$	0.9, 0.1, 0.1, 0.9 [3]
$P_G$	0.0 [3]
$P_B$	0.0, 0.25, 0.5, 0.75, and 1.0 [3]
$P_{AVG}$	0.0, 0.125, 0.25, 0.375, and 0.50[3]
Number of replications per simulation	15
Desired temperature value (°C)	21

### B. Packet Loss Model

To investigate how the packet loss affects the performance of the building temperature control, the packet loss model is assigned in our simulation environments. The packet loss in this study is modeled with a Gilbert-Elliott (GE) error model. This model is one of the widely used wireless channel model used to model the burst loss pattern. The bursty packet loss behavior is common occurred in an indoor wireless network communication due to the multipath propagation and fading effects. Thus, several consecutive packets may lose during

their transmissions which directly influence the stability of the real time closed-loop control system [3]. The GE error model is based on a two-state Markov chain. It has two states: one state is the good state ( $G$ ) or the error-free state, and other is the bad state ( $B$ ) or the error state. In the good state, packet losses occur with low probability ( $P_G$ ). In the bad state, the packet losses happen with high probability ( $P_B$ ). The probability of the state transiting from the good state to the bad state is  $P_{GB}$  ( $P_{GB} = 1 - P_{GG}$ ), and the transition from the bad state to the good state is  $P_{BG}$  ( $P_{BG} = 1 - P_{BB}$ ). The steady state probabilities in good and bad states ( $\pi_G$  and  $\pi_B$ ) are expressed in (1) and (2), respectively. Finally, the average packet loss probability ( $P_{AVG}$ ) from the GE error model is shown in (3)

$$\pi_G = \frac{P_{BG}}{P_{BG} + P_{GB}} \quad (1)$$

$$\pi_B = \frac{P_{GB}}{P_{BG} + P_{GB}} \quad (2)$$

$$P_{AVG} = P_G \pi_G + P_B \pi_B \quad (3)$$

In this study, the parameters  $P_{GG}, P_{GB}, P_{BG}, P_{BB}$ , and  $P_G$  are fixed to 0.90, 0.10, 0.10, 0.90, and 0.00, respectively. We vary the parameter  $P_B$  from 0.00 to 1.00 with a step size 0.25 (i.e. 0.00, 0.25, 0.50, 0.75, and 1.00). Consequently, the  $P_{AVG}$  are equal to 0.00, 0.125, 0.25, 0.375, and 0.50, respectively, as given in Table I. These parameters assigned for our simulation environments are referenced from [3]; they are determined according to the field measurement under realistic indoor environments.

### C. Performance Metrics

The performance measures for evaluating the WSN control system both from the wireless communication and the control system aspects are listed as follows.

- 1) The packet delivery ratio: this metric is the ratio of the total number of data packets sent from the source and the total number of data packets received at the sink. It indicates the levels of the delivered data to the sink node.
- 2) The average jitter duration: This metric represents the average time durations between every two consecutive data packets received by the sink node. It indicates the variation in the delay of received data.
- 3) The total energy consumption of the network: This metric indicates the sum of all nodes' energy consumptions for all activities during the simulation. It is the power consumed by a node in idle, transmit and receive states.
- 4) The settling time: This metric is the time required for the control system output (i.e. the zone temperature) to reach and remain within  $\pm 2\%$  of the set point value. At the settling time, the considered control system approaches its steady state [17]. Therefore, if the control system output does not reach the settling time during the simulation time,

the control system is not controllable (It is still in its transient state).

- 5) The maximum overshoot: This metric is the maximum value of the control system output (i.e. the maximum zone temperature in the room). The maximum overshoot nears the set point value indicating the good control performance.
- 6) The integral of absolute error (IAE) [5]: This metric is the sum of the absolute value of the error between the set point and the measured values. The higher the IAE the worse the control performance.

The packet delivery ratio, the average jitter duration, and the total energy consumption are the performance measures on the reliability, the transmission latency, and the node's energy resource from the wireless communication aspect. The settling time, the maximum overshoot, and the IAE are the performance measures from the control system aspect. Consequently, the relationship between the wireless network communications and the feedback control system can be evaluated by these metrics.

## V. SIMULATION RESULTS AND DISCUSSIONS

### A. Communication Performance

The communication performance in terms of the packet delivery ratio (%) and the average jitter duration are shown in Figs. 3 and 4, respectively. For both the AODV routing solution and the enhanced AODV routing solution as denoted by E-AODV, these two performance metrics are getting worse when the loss rate is set to higher levels. The simulation results also demonstrate that the E-AODV gives the better performance than the traditional AODV routing under varying loss rates. The packet delivery ratio by the E-AODV routing is higher than the case of AODV routing for all packet loss levels. This can directly help to reduce the average jitter duration of successful received packets. Note that there is no data packet received by the sink node when the average loss rate is set to 0.50 in the case of the AODV routing. Thus, the average jitter cannot be determined, as presented in Fig. 4.

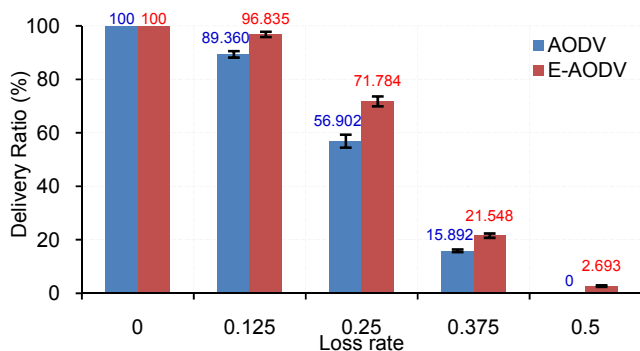

Fig. 3 Packet delivery ratio (%) vs. loss rate

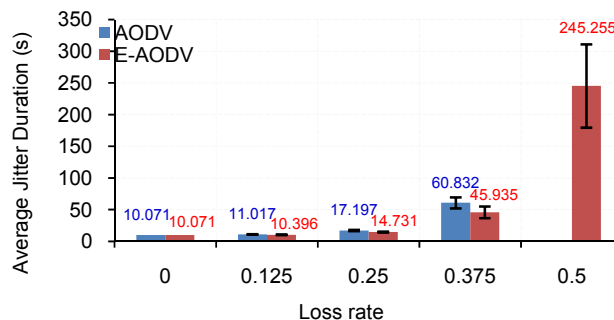

Fig. 4 Average jitter duration vs. loss rate

The reason why the E-AODV solution gives the better performance than the AODV solution is explained here. The E-AODV selects a route for data transmission based on the control system state. When the considered control system is in the transient state indicated by the control system error larger than  $\pm 0.2$ , the E-AODV chooses the route by considering the delay cost as presented in the Algorithms 1 and 2. The route with the maximum delay cost less than other candidate routes is selected. By this technique, the E-AODV routing can automatically avoid to select any routes with high loaded link, packet collision, and packet retransmission probabilities. This can lead to reduce the failure of path-setup procedure and to increase the number of successful received packets.

Fig. 5 illustrates the packet delivery ratio at each interval of time (every 100s) during the simulation time. The finding results indicate that the delivery ratio by the E-AODV and the AODV routings is not different when the loss rate is not included in the simulation, as shown in Fig. 5 (a). At loss rates 0.125-0.25 as shown in Figs. 5 (b) and 5(c), the E-AODV routing gives higher delivery ratio than the AODV routing, especially during the time before 600 s approximately. After this time, the delivery ratio is likely the same. The times before and after 600s (approximation) indicate the transient and the steady states of the building temperature control system which is further discussed in the next subsection. These simulation results confirm that the E-AODV performs better than the AODV during the transient state. For the loss rate at 0.375 and 0.50 as shown in Figs. 5 (d) and 5 (e), the E-AODV routing continuously gives the performance better than the AODV routing. This is because the considered control system cannot be reached its steady state until the end of the simulation time. Therefore, the E-AODV algorithm keeps working by selecting the route with the minimum of the maximum delay cost for data transmission during the simulation period.

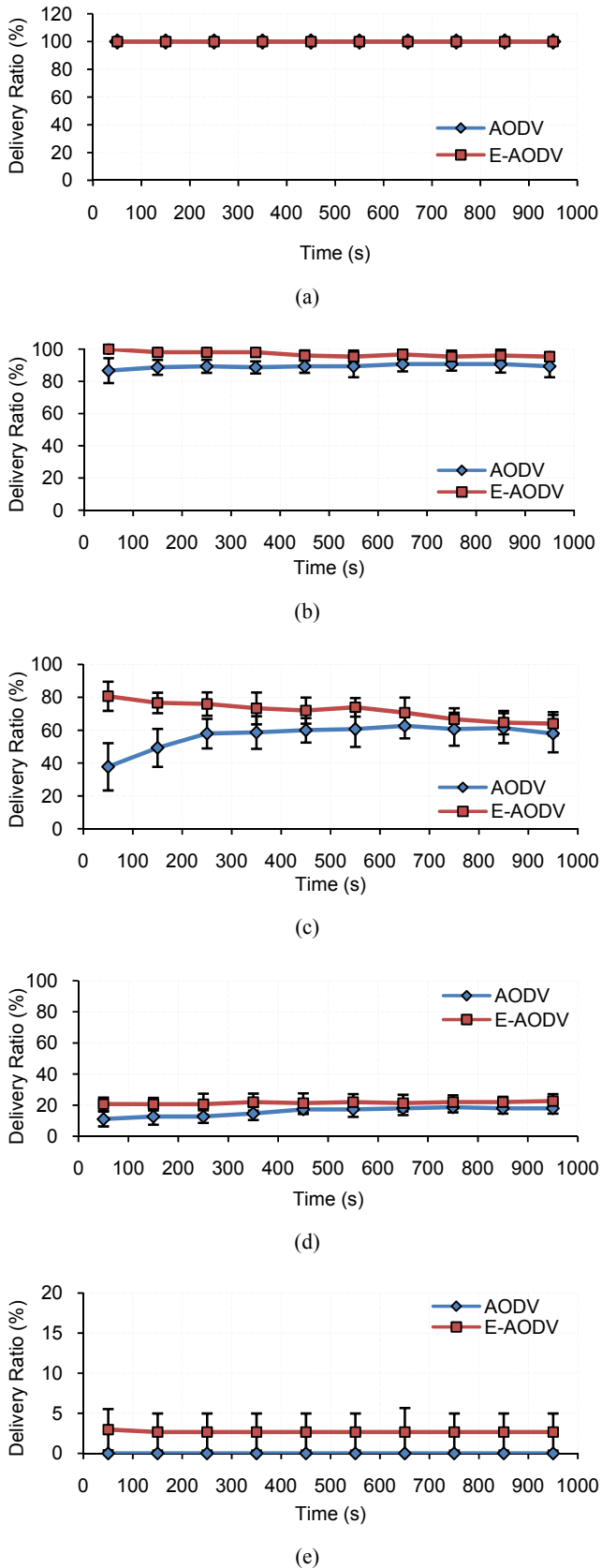

Fig. 5 Packet delivery ratio (%) at each window interval: (a), (b), (c), (d), and (e) represent loss rate levels at 0.00, 0.125, 0.25, 0.375 and 0.50, respectively

Fig. 6 shows the average total energy consumption during varying loss rates. As previously discussed, the E-AODV routing can avoid selecting the route with high loaded link, collisions and retransmissions for data transmission. It can help to decrease the level of route establishment trials and increase the probability of successful data transmission which is confirmed by the delivery ratio results. Thus, the E-AODV routing can directly help sensor nodes to conserve their energies higher than using the AODV routing, especially during the loss rates 0.0-0.375. At the loss rate of 0.50, the total energy consumption by the E-AODV and the AODV routings are not significantly different. Why the total energy consumption is reduced after loss rates 0.375 and why the total energy consumption by both routing approaches are not different at the loss rate 0.50 are further discussed here. For loss rates after 0.375, sensor nodes try to establish the route for sending data hardly. The routes cannot be usually established, and the source node cannot often transmit its sensing data to the sink node. Thus, numbers of signaling exchanging among nodes in the network that indicating the node activities are decreased compared with the case of the loss rate of 0.25; the total energy consumption of the network is also reduced. In addition, at the loss rate of 0.50, the AODV routing cannot setup the route for data transmission during the simulation time while the E-AODV can establish the route sometimes. Accordingly, the numbers of signaling exchanging among nodes by the case of the E-AODV routing are higher than using the AODV approach, so nodes consume their energy resources higher.

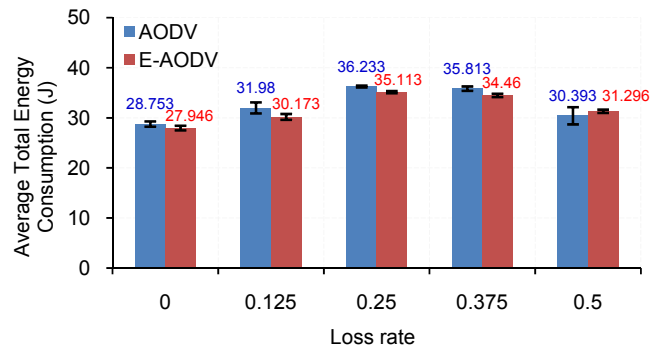

Fig. 6 Average total energy consumption vs. loss rate

### B. Control System Performance

The control system performance as presented by the IAE, the maximum overshoot, and the settling time versus the loss rate are shown in Figs 7, 8 and Table II, respectively. The simulation results demonstrate that the control performance is getting worse when the loss rate is higher for both the AODV and the E-AODV routings. Additionally, the control performance results by both routing solutions are not statically different.

In the E-AODV, at loss rates from 0.00 to 0.25, the sink node connected with the controller can continually receive the measured temperature data as the sensing data from the source node, especially during the transient state of the control system as confirmed by the delivery ratio results from Fig. 5. Due to the high number of temperature data packets received at the sink node, the controller/or the actuator that connected with the sink

node can also continuously feed the inflow air with the updated temperature level into the room. As a result, the considered control system can reach the desired target within a small period of time. Although there are loss packets after the control system reaches its steady state, the control system is still controllable in the case of using the E-AODV routing. This is because the packet loss during the steady state of the building temperature control system slightly influences the system. This situation can be explained that when the control system achieves its steady state, the zone temperature in the room is stable within  $\pm 2\%$  of the set point value. If no data packet from the source node is received by the sink node, the actuator continuously feeds the supply air temperature to the room by using the previous control value as determined from the latest control system error. In the steady state, the supply air temperature as an input by the actuator approaches the appropriate value for the given physical system. As a result, the zone temperature is still within the set point value although the actuator does not receive any new measured temperature information.

For loss rates 0.375 and 0.50, although the E-AODV gives the better communication performance results than the AODV, the considered control system cannot be control to the desired level. We can see that the settling time as shown in Table II at these loss rates are larger than 1000s. This means that the control system does not reach the desired target within the simulation time. Due to the high probability of packet loss occurring during the simulation time, the average jitter duration calculated from the time to receive packets at the sink is always larger than the maximum allowable loop delay as equal to  $T_r/4$  [22], [23]. As a result, the control system in this case cannot be controlled to the set-point. Note that to guarantee an acceptable control performance of the feedback control system from the control system theory, the sampling period (as related to the maximum allowable loop delay) should be set to 4 to 10 samples per rise time ( $T_r$ ) [22]-[24]. The rise time is the time required for the control system output to rise from 0% to 100% of the set point value. Thus, the maximum sampling period as the maximum allowable loop delay [22], [23] is equal to  $T_r/4$ . In this study, the rise time is 179 s, so  $T_r/4$  is equal to 44.75. The average jitter durations at loss rates of 0.375 and 0.50 as shown in Fig. 4 are larger than this threshold.

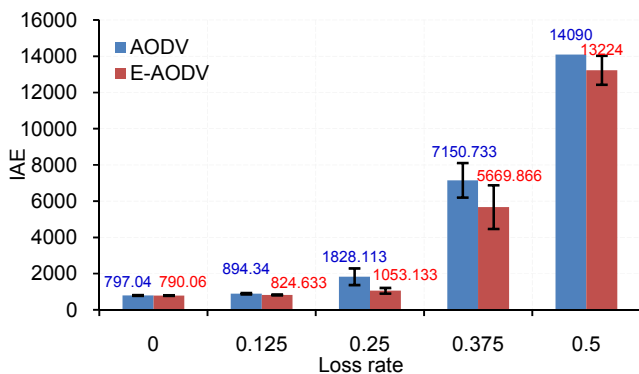

Fig. 7 IAE vs. loss rate

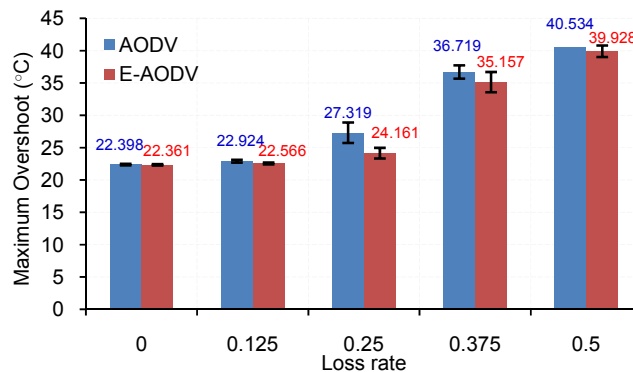

Fig. 8 Maximum overshoot vs. loss rate

TABLE II  
SETTLING TIME VS. LOSS RATE

Loss rates	Settling time (s)			
	AODV	95% ci	E-AODV	95% ci
0.000	589.600	1.676	589.066	1.424
0.125	590.866	2.507	589.266	2.306
0.250	687.266	33.615	608.466	18.999
0.375	>1000	-	>1000	-
0.500	>1000	-	>1000	-

Note that 95% ci as presented in Table II is the 95% confidence interval

## VI. CONCLUSION

This paper evaluates the performance of routing algorithms on WSNs for control applications, focusing on both wireless network communication and control system perspectives. The proposed routing algorithm as the joint communication and control design algorithm is proposed for this study. The proposed routing finds a route for data transmission by taking the control system error and the packet transmission latency over a wireless link into account. For the evaluation, a building temperature control scenario is employed as a control application model. The physical system is the zone temperature model, and the controller is the PID control algorithm. The wireless network communication is based on the IEEE 802.15.4 standard. The simulation results show that the performance of the control system directly depends on routing mechanisms. The proposed routing algorithm gives the better performance than the original AODV routing protocol when considering the wireless network communication performance. However, the control performance by our solution is not much improved.

## ACKNOWLEDGMENT

This work was fully supported by the Telecommunication Research and Industrial Development Institute (TRIDI), National Telecommunication Commission (NTC) under Grant PHD/008/2552/. This research work was also supported by NECTEC-PSU center of excellence in Wireless Sensor Networks and Faculty of Engineering, Prince of Songkla University, Thailand.

REFERENCES

- [1] I. F. Akyildiz and I.H. Kasimoglu, "Wireless Sensor and Actor Networks: Research Challenges," *Ad Hoc Networks Journal*, vol. 2, no. 4, pp. 351-367, 2004.
- [2] S. Nethi, M. Pohjola, L.M. Eriksson, and R. Jantti, "Simulation Case Studies of Wireless Networked Control System," in *Proceedings of the 10<sup>th</sup> ACM/IEEE International Symposium on Modeling, Analysis and Simulation of Wireless and Mobile Systems*, pp. 100-104, 2007.
- [3] M. Bjorkbom, S. Nethi, L.M. Eriksson, and R. Jantti, "Wireless Control System Design and Co-simulation," *Control Engineering Practice*, vol. 19, pp. 1075-1086, 2011.
- [4] J. Chen, X. Cao, P. Cheng, and Y. Xiao, "Building-environment Control with Wireless Sensor and Actuator Networks: Centralized versus Distributed," *IEEE Transaction on Industrial Electronics*, vol. 57, no. 11, pp. 3596-3605, 2010.
- [5] X. Feng, T. Yu-Chu, L. Yanjun, and S. Youxian, "Wireless Sensor/Actuator Network Design for Mobile Control Applications," *Sensors 2007*, vol. 7, no. 10, pp. 2157-2173, 2007.
- [6] P. Han, H. Wu, D.M. Dilin and C.S. Gao, "ELRS: An Energy-efficient Layered Routing Scheme for Wireless Sensor and Actor Networks," in *Proceedings of the 20<sup>th</sup> International Conference on Advanced Information Networking and Applications*, vol. 2, pp. 452-460, 2006.
- [7] A. Boukerche, R.B. Araujo and L. Villas, "A Wireless Actor and Sensor Networks QoS-aware Routing Protocol for the Emergency Preparedness Class of Applications," in *Proceedings of the 31<sup>st</sup> Annual IEEE Conference on Local Computer Networks*, pp. 832-839, 2006.
- [8] J. Chen, Y. Zhang, X. Cao and Y. Sun, "A Communication Paradigm for Wireless Sensor/Actuator Networks," in *Proceedings of the International Conference on Sensor Technologies and Applications*, pp. 70-75, 2007.
- [9] A. Boukerche, R.B. Araujo and L. Villas, "Optimal Route Selection for Highly Dynamic Wireless Sensor and Actor Networks Environment," in *Proceedings of the 10<sup>th</sup> ACM International Symposium on Modeling, Analysis and Simulation of Wireless and Mobile Systems*, pp. 21-27, 2007.
- [10] A. Boukerche, R. B. Araujo and L. Villas, "A Novel QoS Based Routing Protocol for Wireless Actor and Sensor Networks," in *Proceedings of the IEEE Global Communication Conference*, pp. 4931-4935, 2007.
- [11] Z. Dai, Z. Li, B. Wang and Q. Tang, "An Energy-Aware Cluster-Based Routing Protocol for Wireless Sensor and Actor Networks," *Information Technology Journal*, vol. 8, pp. 1044-1048, 2009.
- [12] L. Barolli, T. Yang, G. Mino, F. Xhafa and A. Duresi, "Routing Efficiency in Wireless Sensor-Actor Networks Considering Semi-Automated Architecture," *Journal of Mobile Multimedia*, vol. 6, no. 2, pp. 97-113, 2010.
- [13] Z. Dai, B. Wang, Z. Li and A. Yin, "VDSPT: A Sensor-Actor Coordination Protocol for Wireless Sensor and Actuator Network Based on Voronoi Diagram and Shortest Path Tree," in *Proceedings of the International Symposium on Computer Network and Multimedia Technology*, pp. 1-4, 2009.
- [14] M.A. Khan, G.A. Shah, M. Ahsan, and M. Sher, "An Efficient and Reliable Clustering Algorithm for Wireless Sensor Actor Networks (WSANs)," in *Proceedings of the 53<sup>rd</sup> IEEE International Midwest Symposium on Circuits and Systems*, pp. 332-338, 2010.
- [15] H.J. Chang, G.T. Park, "Coordinator Assignment Scheme and Routing Algorithm for Wireless Sensor and Actuator Networks," in *Proceedings of the 2<sup>nd</sup> International Conference on Education Technology and Computer*, pp. 406-410, 2010.
- [16] P. Park, C. Fischione, and A. Bonivento, "Breath: An Adaptive Protocol for Industrial Control Application Using Wireless Sensor Networks," *IEEE Transactions on Mobile Computing*, vol. 10, pp. 281-332, June, 2010.
- [17] N.S. Nise, "Control Systems Engineering," 4<sup>th</sup> Edition, John Wiley: New York, 2004.
- [18] A. Booranawong, W. Teerapabkajornet, and C. Limsakul, "Energy Consumption and Control Response Evaluations of AODV Routing in WSANs for Building-Temperature Control," *Sensors 2013*, vol. 13, no. 7, pp. 8303-8330, 2013.
- [19] T. Kohtamaki, M. Pohjola, J. Brand, and L.M. Eriksson, "PiccSIM Toolchain-design, Simulation and Automatic Implementation of Wireless Networked Control Systems," in *Proceedings of the IEEE International Conference on Networking Sensing and Control*, pp. 49-54, March 2009.
- [20] T. Instruments, "CC2420 Datasheet," Available online: <http://www.ti.com/lit/ds/symlink/cc2420.pdf> (accessed on 20 November 2013).
- [21] P. Pivato, L. Palopoli, D. Petri, "Accuracy of RSS-based Centroid Localization Algorithm in an Indoor Environment," *IEEE Transaction on Instrumentation and Measurement*, vol. 60, no. 10, 2011.
- [22] K. Ji, and W.J. Kim, "Optimal Bandwidth Allocation and QoS-adaptive Control Co-design for Networked Control Systems," *International Journal of Control, Automation, and Systems*, vol. 6, no. 6, pp. 596-606, 2008.
- [23] T. Bai, Z.M. Wu, and G.K. Yang, "Optimal Bandwidth Scheduling of Networked Control Systems (NCSs) in Accordance with Jitter," *Journal of Zhejiang University SCIENCE*, vol. 6, no. 4, pp. 535-542, 2005.
- [24] M. Bjorkbom, "Wireless Control System Simulation and Network Adaptive Control," Ph.D. dissertation, Department of Automation and Systems Technology, Aalto University, Finland, 2010.

**Apidet Booranawong** received the B. Eng. and M. Eng. degrees in Electrical Engineering-Telecommunications from Walailak University and Prince of Songkla University in 2007 and 2009, respectively. Currently, he is pursuing the Ph.D. degree at Electrical Engineering-Telecommunications, Prince of Songkla University, Thailand. His research interests are wireless sensor and actuator networks and wireless networked control systems.

**Wiklom Teerapabkajornet** obtained the B. Eng. degree in Electrical Engineering from Prince of Songkla University, Thailand, in 1992 and the Ph.D. degree in Telecommunications from the University of Pittsburgh, USA, in 2004. Currently, he works as an Assistant Professor in the Department of Electrical Engineering, Prince of Songkla University. His research interests are wireless communication, wireless ad-hoc and sensor networks.