

Electromyogram of the Cibarial Pump and the Feeding Process in Hematophagous Hemiptera

Ricardo N Araujo¹, Nelder F Gontijo¹, Alessandra A Guarneri²,
Alberto F Gontijo³, Adriana C Soares¹ and Marcos H Pereira¹

¹*Departamento de Parasitologia, Instituto de Ciências Biológicas
Universidade Federal de Minas Gerais*

²*Centro de Pesquisas René Rachou, Fiocruz*

³*Colégio Técnico da Universidade Federal de Minas Gerais; Belo Horizonte, Minas Gerais
Brazil*

1. Introduction

The feeding process of hematophagous insects constitutes an important period in their life cycle. During this process, the insect is in close contact with its host, the blood required for reproduction and completion of insect development is obtained and pathogens can be transmitted. Several studies have focused on this period using different tools to monitor the details of feeding, with particular attention given to electromyograms of the cibarial pump. The cibarial pump is a structure associated with a complex of muscles located in the head of the insect. It controls the ingestion of blood from the host and transfers it to the gut. Monitoring of the frequency and shape of the electrical signals produced by this muscle complex enables the phases and parameters of the feeding process to be precisely determined and allows any disturbance or feature that may affect hematophagy to be evaluated. In this chapter we review technical and methodological issues that allow cibarial pump electromyograms to be used in studying the insect blood-feeding process and describe the results that may be obtained from such a system.

2. The feeding process in hematophagous hemiptera

Hemiptera is an order of insects comprising around 50,000–80,000 species with a variety of feeding habits. Hematophagy is seen in the hemipteran families Lygaeidae, Anthocoridae, Cimicidae, Polycytenidae and Reduviidae. The hematophagous species of the Reduviidae are included in the subfamily Triatominae. Triatomines and cimicids are the most studied hemipteran groups due to their medical importance. Species of both families live inside dwellings and feed on human blood (Schofield, 1995). The relatively large size of the hematophagous cimicids and triatomines facilitates their use in feeding behavior experiments. Moreover, colonies of the main species can be easily reared under laboratory conditions using several vertebrates as hosts.

Triatomines and cimicids are vessel-feeders or “solenophages”, i.e., they obtain blood directly from the blood vessels (venules or arterioles) of vertebrate hosts (Lavoipierre et al., 1959). Their feeding process involves several steps, including puncturing of the host skin, a

probing phase which consists of identification and cannulation of a blood vessel, an engorgement phase, during which blood is removed from the host and transferred to the gut of the insect and finally cessation of feeding, when ingestion of blood stops and the mouthparts are removed from the host's skin. These processes differ slightly between triatomines and cimicids, due mainly to variations in gut physiology, mouthpart morphology and the amount and variety of biological molecules produced by the salivary glands and intestine. The main processes involved in the feeding of each group of insect are explained below.

a. Triatomines

The mouthparts of triatomines are composed of a three-segmented labium (or proboscis), a pair of mandibles and a pair of maxillae. Each maxilla articulates with the other and forms two canals: the alimentary canal through which blood passes and the salivary canal that conducts saliva to the feeding site (Figure 1). To initiate feeding, triatomines choose a suitable spot on the host skin where they anchor the feeding apparatus to the surface. They then use their mandibles (serrated structures contained in the mouthparts) to puncture the skin (Figure 2a). The long, flexible maxillae are introduced into the skin and initiate the probing phase, which is characterized by whip-like movements of these structures in the skin as the insect seeks a vessel to cannulate (Figure 2b) (Lavoipierre et al., 1959). At the same time, the cibarial pump produces periodic, isolated contractions that remove fluid samples for analysis by epipharyngeal chemoreceptors (Smith & Friend, 1970). The probing phase lasts until the maxillae are able to cannulate the vessel (Figure 2c).

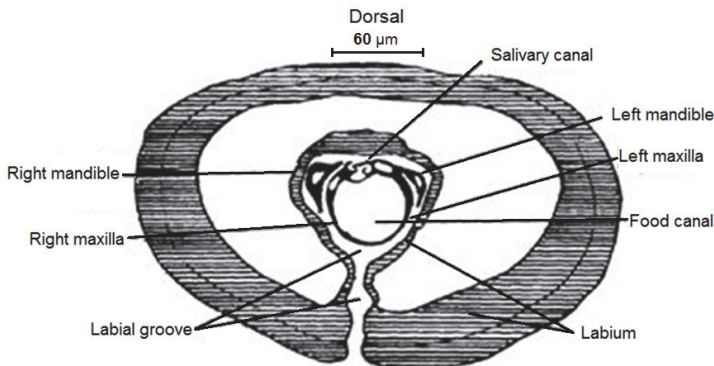

Fig. 1. Transverse section near the base of the proboscis of a fifth instar nymph of *Rhodnius prolixus* (redrawn from Lavoipierre et al., 1959).

The engorgement phase starts after the maxillae enter a blood vessel. This phase corresponds to the period when the insect extracts blood from the vessel through the mouthparts and transfers it to the gut. During this process, blood passes along the alimentary canal, through the foregut or esophagus to reach the anterior midgut, where it is stored. Pumping of blood involves a chambered structure associated with a complex of muscles located in the head of the insect, known as the cibarial pump. When the cibarial pump-associated muscles are contracted, a negative pressure is created in the chamber which draws blood up from inside the vessel. When the muscles relax, the chamber closes and pushes blood into the gut (Bennett-Clark, 1963). The contractions of the cibarial pump

are sequential, repetitive and usually occur at regular intervals. This is the longest phase of the feeding process and can last from a few minutes to more than an hour, depending on the insect species, development stage and other characteristics of the insect and the host that may favor or delay the ingestion of blood.

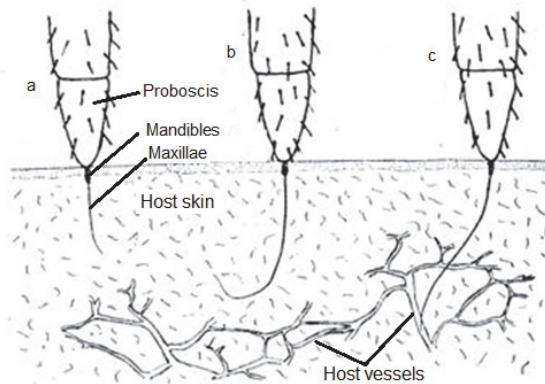

Fig. 2. Steps in the triatomine feeding process. a) puncture of the skin by the mandibles and introduction of the maxillae; b) whip-like movements of the maxillae in search of a blood vessel; c) cannulation of the blood vessel by the maxillae (redrawn from Lavoipierre et al., 1959).

b. Cimicids

The feeding process of cimicids is very similar to that of triatomines. Bedbugs (as these insects are popularly known) also have a feeding apparatus adapted to feed on fluids, with mouthparts consisting of several structures. A pair each of mandibles and maxillae (together forming a fascicle) align to form the alimentary and salivary canals (Figure 3). Although cimicids such as *Cimex* also take blood directly from the vessels of the host, their mandibles function in a different way from those of triatomines, penetrating deeply inside the dermis (Figure 4b) and supporting the maxillae which in cimicids they are the only structures that penetrate the blood vessel (Figure 4c) (Dickerson & Lavoipierre, 1959).

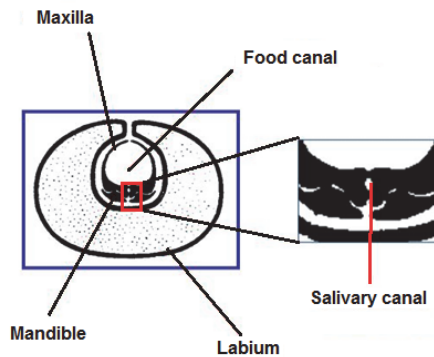

Fig. 3. Transverse section of the feeding apparatus of *Cimex lectularius* (redrawn from Schofield & Dolling, 1996).

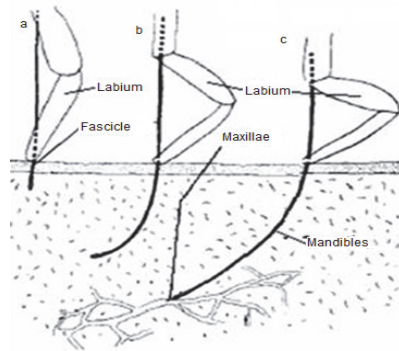

Fig. 4. Feeding behavior of the fascicle of *Cimex lectularius* in the host skin (redrawn from Dickerson & Lavoipierre, 1959). a) puncture of the skin by the mandibles; b) introduction of the fascicle into the dermis; c) mandibles give support to the maxillae that penetrate the blood vessel.

The feeding process of *Cimex lectularius* begins with the penetration of the fascicle into the host skin. The fascicle, which is highly flexible, carries out probing movements in all directions. These movements cease when a suitable vessel is found and cannulated (Figure 4). During these active movements of the fascicle, small hemorrhagic spots are formed (Dickerson & Lavoipierre, 1959). Based on histological observations, these hemorrhages led Gordon & Crewe (1948) to conclude that *Cimex* were telmatophagic or "pool feeders". However, Dickerson & Lavoipierre (1959) made direct observations with intravital microscopy and concluded that *Cimex* in fact feeds directly within the host blood vessel and is therefore solenophagic.

The engorgement phase in cimicids begins after probing movements have been completed. This phase is characterized by the rhythmic functioning of the cibarial pump, which promotes a negative pressure inside the blood vessel, propelling blood into the gut. The pump (Figure 5) is formed by a chamber with dorsal and lateral associated-muscles and is linked to the short esophagus (Snodgrass, 1944).

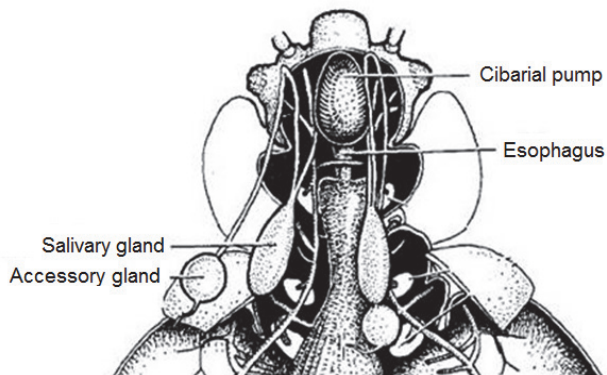

Fig. 5. Internal anatomy of the anterior part of *Cimex lectularius* (redrawn from Usinger, 1966)

3. Functional anatomy of the cibarial pump

The ingestion of blood by triatomines is promoted by the cibarial pump, which along with its associated musculature nearly fills the insect head capsule. The pump of a fifth instar nymph of *Rhodnius prolixus* consists of a rigid, ventrally positioned, U-shaped chamber, about 3.5 mm long by 0.28 mm wide and attached to an elastic ligament on either side which is more elastic and acts as a piston (Figure 6). The apical diameter of the chamber is about 10 μm . The pump is attached to the floor of the head by interstitial tissue. The piston is connected to the upper part of the head by two V-shaped muscle bundles. The first bundle is longer and is localized in the anterior part of the pump while the second is approximately seven times smaller and located distally (Figure 7) (Bennet-Clark, 1963). The pump is filled through contraction of these muscles and emptied by the retraction of the piston by means of the contraction of a ligament (Snodgrass, 1935; Smith, 1985), aid by the pre-cibarial valve and its associated muscles (Backus & McLean, 1982; McLean & Kinsey, 1984).

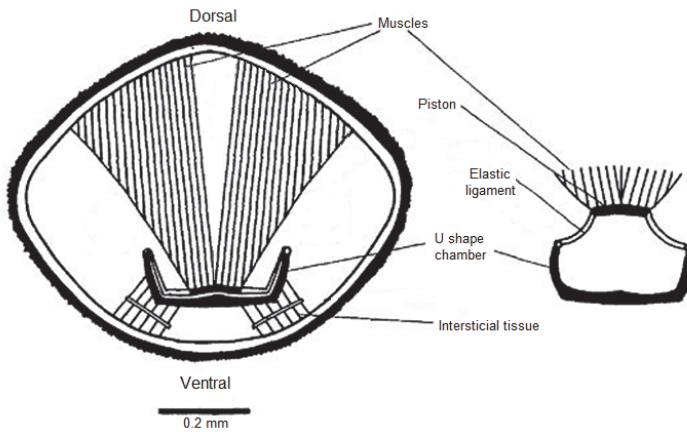

Fig. 6. Transverse cross-section of the head of a fifth instar nymph of *Rhodnius prolixus* showing the U-shape of the cibarial pump and the associated muscles contracted and relaxed (redrawn from Bennet-Clark, 1963).

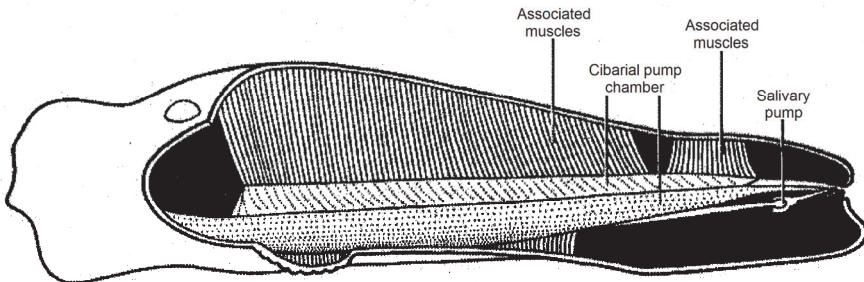

Fig. 7. Longitudinal cross-section of the head of a fifth instar nymph of *Rhodnius prolixus* head showing the cibarial pump and associated muscles (redrawn from Perez, 1969).

The cibarial pump supplies the force to move blood from the vessel to the insect midgut. A fifth instar nymph of *R. prolixus* consumes approximately 300 μL of blood in 5 minutes, which suggests (based on conservative calculations), that the cibarial pump produces a negative pressure of over 1-2 atmospheres during feeding (Bennet-Clark, 1963). During the engorgement phase, muscles associated with the cibarial pump contract sequentially and repetitively to allow ingestion of blood by the bug. Throughout the feeding period, the frequency of contractions can vary from 6 Hz (in periods when blood is easily ingested) to less than 1 Hz (when the insect is having problems in obtaining blood from the vessel).

4. History of the use of electrical recording in the study of triatomine blood-feeding behavior

The standard technique for studying feeding behavior in triatomines was developed in the 1970's by Smith & Friend, based on the models already used for studies of aphids (McLean & Kinsey, 1964; Tjallingii, 1985). Smith & Friend (1970) observed the action of the cibarial pump using an electrical resistance technique, carrying out modifications in order to capture clear signals. One of these was to avoid the use of a voltage source in series with the animal; a signal of sufficient strength could be obtained by simply connecting two platinum electrodes (one each on the thorax and bloodmeal), to the input of a Grass Pi5 high input-impedance preamplifier (Smith, 1979). A further modification was to record from the brass mesh on which the animal rested during feeding, rather than from an electrode in the thorax. This modification enabled signals to be acquired from the cibarial pump of early instar nymphs, which are too small to allow an electrode to be affixed to the thorax. Although this produced a much noisier signal due to the additional resistive pathway through the animal and movements of the tarsi, filtering the output of the preamplifier with a step band-pass filter (General Radio Type 1952 Universal Filter), usually allowed the pump strokes (though not the shape of the resistance changes) to be distinguished from the noise. A bandwidth of about 30-200 Hz was usually employed. Most records were obtained in this manner, since it involved no manipulation of the animals and these would therefore feed more readily. A storage oscilloscope and/or a Brush Mark 280 pen recorder were used to observe the shape and duration of changes in signal associated with pumping. The signal triggered the sweep of a second oscilloscope to record the number of strokes of the cibarial pump, as well as the pumping frequency. A signal derived from the sweep circuit was then used as the input to a rate meter and a pulse counter. The output of the rate meter was recorded on a chart recorder. The origin of the voltage changes recorded is unknown. They may represent impedance changes, in association with a voltage source such as a junction potential between electrodes and the hemocoel or diet, or else they reflect the current produced by activity of the pump muscle, in a manner analogous to that of an electrocardiogram.

In the following discussion, we describe a new system derived from that created by Smith & Friend that can be used to record and analyze the electrical signals produced by the cibarial pump during the insect feeding process. We also show how the use of this technology, together with live microscopy (intravital microscopy) of the cibarial pump, led to the conclusion that the electrical signals produced are related to the activity of muscles associated with the pump.

5. Acquisition system and treatment of the electrical signals produced during the feeding process

The acquisition system is based on the connection of one electrode to the insect, another to the host, and both to a detection system (Figure 8). The electrodes consist of fine wires, usually gold with a diameter of 90 μm and are connected to the back of the insect (Figure 9) and to the host skin with a small piece of tape. Contact between the electrode and insect/host is increased by using a conductive electrolytic gel (Regisgraf-Gel®).

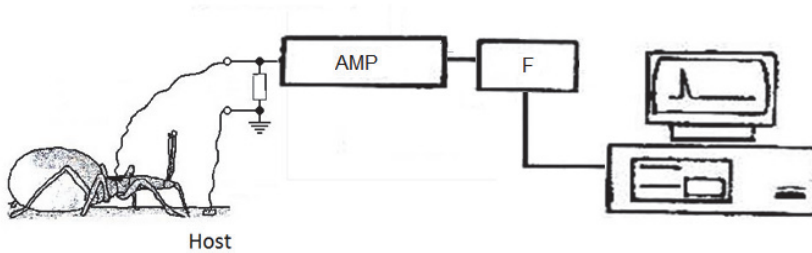

Fig. 8. Basic system and connections to detect the electrical signals produced by the cibarial pump of insects. AMP - amplifier; F- filter.

Provided insects remain immobile during the feeding process, the only relevant muscles that contract are those associated with the cibarial pump, allowing their electrical signals to be detected. However, insects have an exoskeleton made of chitin which has a very high electrical resistance. Thus an amplifier of high input impedance and high gain is required to pick up electrical signals, which have a peak-to-peak order of magnitude of 1 mVpp, from the suction process (Prutchi & Norris, 2005). These two properties favor the uptake of 60 Hz noise from the power grid, as well as of radiofrequency signals in general. Shield cables and amplifier configurations with a high common-mode rejection rate should therefore be used. Another problem that must be overcome in the amplifier is the DC voltage signals generated by the electrolytic potential of fine wire in contact with the conductive gel. This voltage can vary with the type of metal used to make the electrode, the type of the gel used, and also the local temperature. DC voltage changes of electrodes are slow (in the order of seconds) and must be automatically compensated by the amplifier.

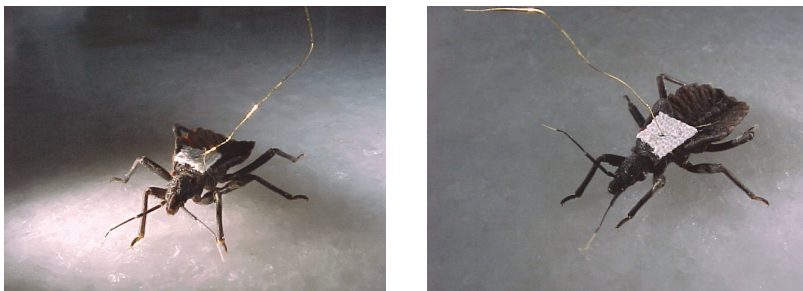

Fig. 9. Gold wire electrodes fixed on the back of an insect used to pick up electrical signals during the feeding process.

For assays with artificial feeders, the electrode is immersed directly in the diet. When insects are placed on a metal mesh rather than fixing electrodes to the thorax, the metal mesh should also be moistened with the electrolytic gel.

Operational amplifiers with J-FET (TL071) are used in the input of the acquisition system. These have high impedance ($\sim 10^{12}\Omega$) and form a traditional instrumentation amplifier configuration (Figure 10). A $47\text{M}\Omega$ resistor defines the impedance in the entrance of the amplifier, and avoids overcharging the signal from the surface of the insect. Although we would have preferred to use differential entrances directly on the body of the insect to increase the common mode rejection rate, this type of configuration was not viable due to difficulties in fixing the electrode to the ventral surface of the insect and the interference that this would cause to the feeding process.

A RC low-pass first-order filter with cut-off frequency of approximately 16 kHz was set into the amplifier input to prevent entry of radiofrequencies eventually picked up by the wires. Any DC voltage in the non-inverting input tends to appear amplified in the output of the block, being due to feedback to the inverting input by a passive RC filter with a high time constant. After some seconds, the DC signal is minimized in the output, since it will appear simultaneously in both inverting and non-inverting input.

After the amplifier block, there are three filtering circuits: a notch section centered on 60 Hz and two sections of a second order Butterworth filter (Figure 10). The final blocks are the digitalization of the signals and their visualization using a control software. The digitalizing interface has a 12-bit digital-analog converter, with adjustable sampling rate. The control software establishes the input sensibility and the sampling frequency. The output signal is shown in Figure 11.

The components were assembled in a fiberglass printed circuit board and packed in a metallic box with good electromagnetic shielding. The circuit was fed by 9V batteries to avoid the entrance of 60 Hz noise from any rectified power supply. The input and output of the apparatus used shielded wires with grounded outer sheaths. Ω

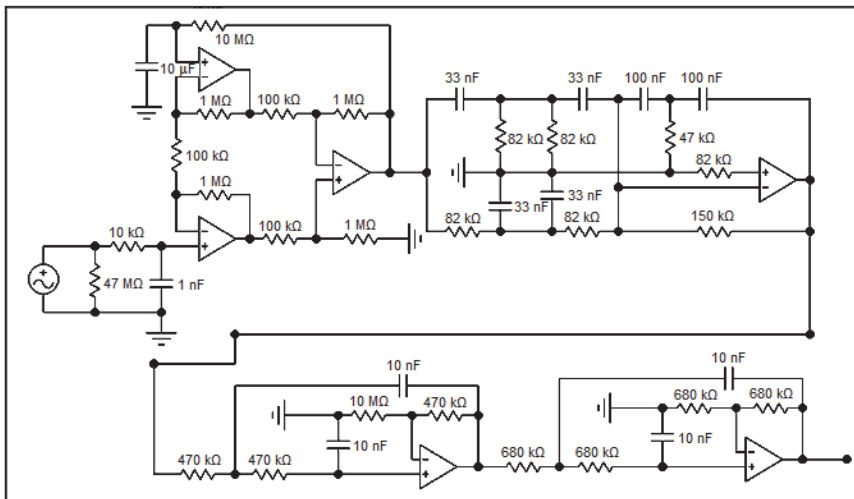

Fig. 10. Sketch of the amplifier and low-pass filter.

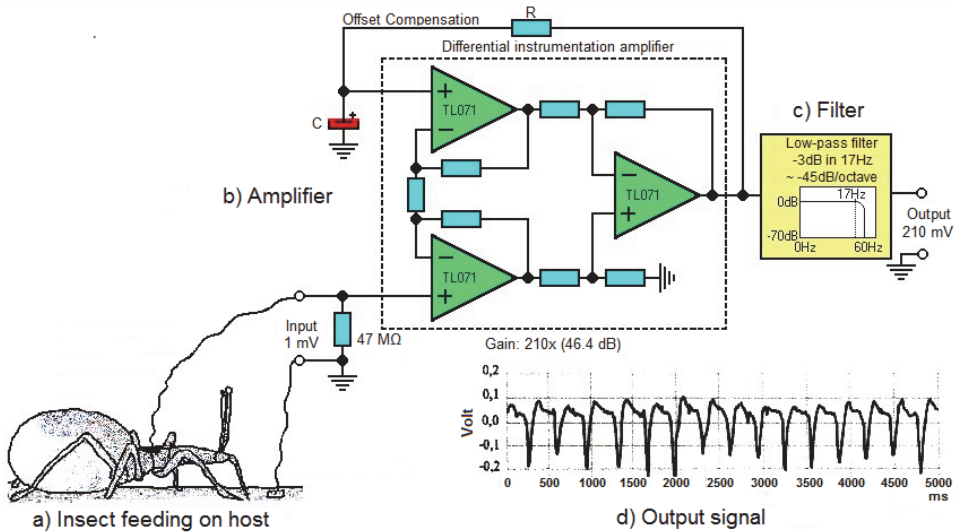

Fig. 11. General sketch of the electronically monitoring of the cibarial pump. (a) the signals produced are collected by gold wires fixed onto the dorsal surface of the insect and on the host skin; (b) the signals are amplified 210 times, (c) signals are filtered by a low-pass filters and digitalized by a AC-100 plate connected to a computer, (d) signal's mV variation are shown on the computer screen. TL071 - Operational amplifiers with J-FET; R - resistor; C - capacitor.

The control software operates in two modes - i.e., data acquisition mode and analysis & visualization. In the data acquisition mode some parameters are adjusted before the acquisition of the signal such as the sensibility, sampling rate and the scale of the on-screen abscissa. The conversion and time recording start on zero and the converted data are recorded on a matrix with 360,000 positions and shown on the screen. Acquisition time varies from 30 minutes (at the highest sampling rate - 200 samples/second) to 5 hours (at the lowest acquisition rate - 20 samples/second).

When data acquisition ends, the user should change to the analysis and visualization mode, where the recorded data can be visualized as desired. The data can be saved in the hardware or a disc, generating a *name.dat* file, which can be launched or transferred to external software for analysis.

Analysis of the signals collected can be manually or automatically analyzed, each of them important in verifying different parameters of the feeding process. For manual analysis the user should load the *.dat* file and visualize the format of the signals throughout the experiment. Automatic analysis can be performed in the software MATLAB® (MathWorks Inc.) or the very similar Octave (<http://www.octave.org>), using the functions "fft" and "specgram" (MathWorks, 1995). The function "fft(a,n)" calculates the discrete Fourier transformation of vector "a", computed with the algorithm of the rapid Fourier transform. The Fourier transformation can be used to find the harmonic components of the frequencies from a signal of physiological origin in relation to time. The "n" parameter specifies the number of points or samples used in the FFT.

The function “specgram” calculates the discrete Fourier transformation from a signal stored in the vector “a” using the sliding window technique (Figure 12). The spectrogram represents the magnitude of this function. In cases where the insects alter the contracting profile during feeding, computing a more localized FFT by considering only the subset of points from a small window that slides along vector “a” allows visualization of the feeding behavior versus time in relation to the harmonic content of the signals collected. The line below shows a command to the function “specgram” containing a higher number of configuration parameters:

```
B = specgram(a, nfft, Fs, window, noverlap, 'dflag');
```

The number of points (nfft) that comprise the window can be adjusted by the user as well as the superposition between windows.

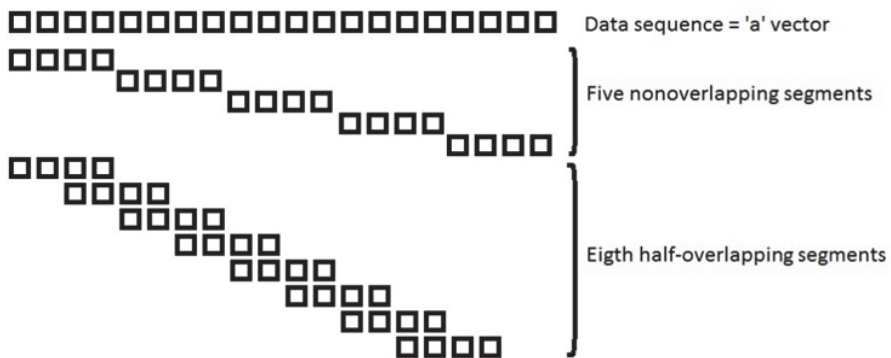

Fig. 12. Sliding window technique used in the “specgram” function.

Since each value of the vector “a” only supplies information on the signal amplitude throughout successive sampling, the temporal dimension of the experiment is lost. The parameter F_s informs the function of the sampling frequency used to obtain the data. The value $T=1/F_s$ provides the time interval between samples. These adjustments set the vertical axis of the spectrogram to the correct Hz scale and the horizontal axis to time in seconds.

The output graphic shows the intensity of the components of the frequencies based on color tones (Figure 13). The weakest and strongest intensity signals are represented by blue and red tones, respectively.

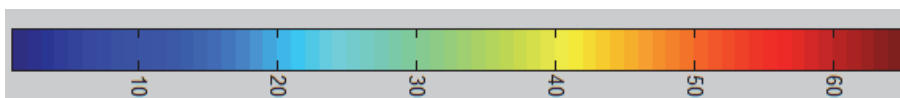

Fig. 13. Colors in the graph generated by function “specgram” indicate the intensity of the signals.

Rapid Fourier transformation can only be done in periodic signals and the points from the block of data may not satisfy this requirement. A conformant function then forces the signal into periodic by multiplying the samples by a window whose main characteristic is that it begins and ends with values close to zero. This technique inserts distortions in the real signal spectrum, hence the importance of the type of window function to be multiplied.

The parameter 'window' specifies the type and size (number of points) of the multiplier function. There are several window functions, including boxcar, bartlett, hamming, hanning, kaiser, etc. The length of the window function should be lower than or equal to nfft. Figure 14 shows three examples of windows, each with 65 points.

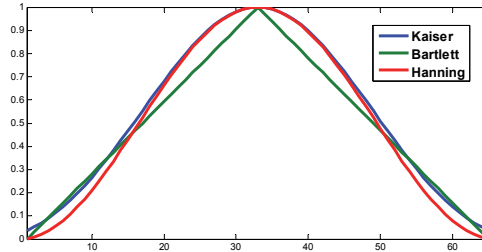

Fig. 14. Examples of windows used to convert signals to periodic.

Figures 15 to 20 show the steps followed by the functions "fft" and "specgram" to process the signals collected during blood-feeding. Figure 15 presents a small extension of the signals of the electromyogram with 1,024 points from the middle of an experiment. Figure 16 shows the extension of the signals after the elimination of the average value ("detrend" function).

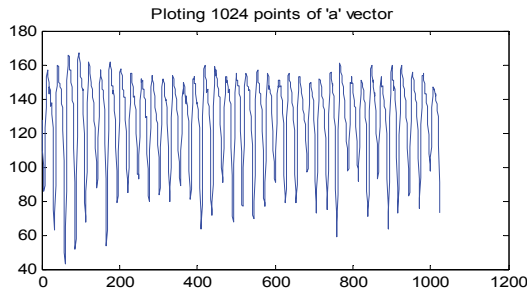

Fig. 15. 1024 points from vector "a".

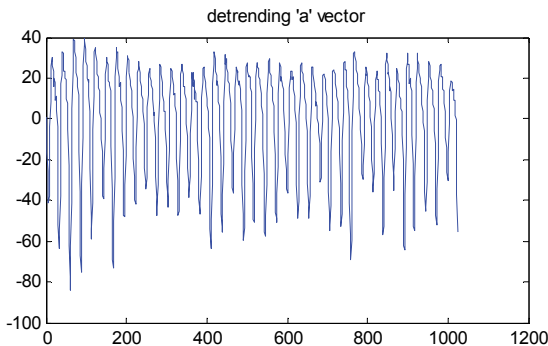

Fig. 16. Elimination of the average value from "a".

Figure 17 shows the shape of the Hanning window that will be multiplied by the pre-processed signal shown in Figure 16. Figure 18 shows the profile of the windowed signal after multiplication by the Hanning window.

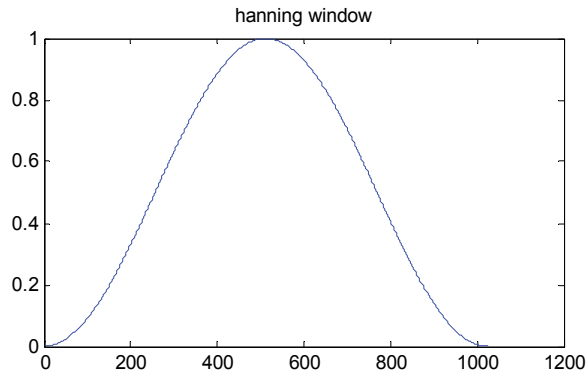

Fig. 17. Format of the Hanning window.

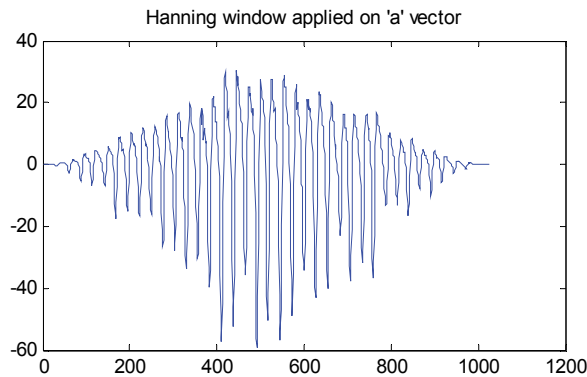

Fig. 18. Hanning window applied to the block of data.

Figure 19 shows the spectrum generated by the FFT with peaks of energy localized in well-defined frequencies. The peak marked with a red dot (7.5659 Hz) is the fundamental frequency of the signal collected. The second and third peaks represent the harmonic frequencies of the fundamental frequency.

Finally, Figure 20 shows the spectrogram of the entire experiment, which has a duration of approximately 15 minutes. There is no signal at the first seconds because the triatomine has yet to make contact with the host. Probing begins, followed by the engorgement phase which is characterized by a strong and stable signal with well-defined frequencies. The energy of the signal collected is strongly concentrated within two or three harmonic frequencies. Small frequency variation can be perceived over time. At the end of the experiment, the signal resumes presenting disturbances and noises that remove part of the energy from the harmonic frequencies, visible as a blurred spectrum.

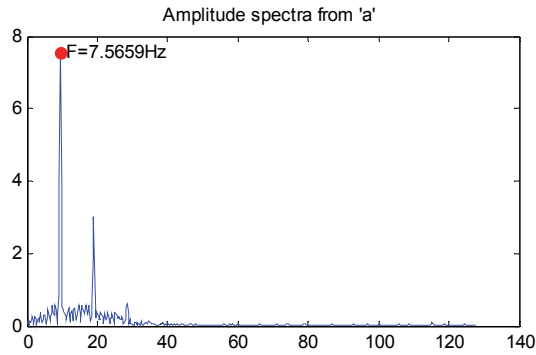

Fig. 19. Identification of the fundamental frequency of the signal analyzed.

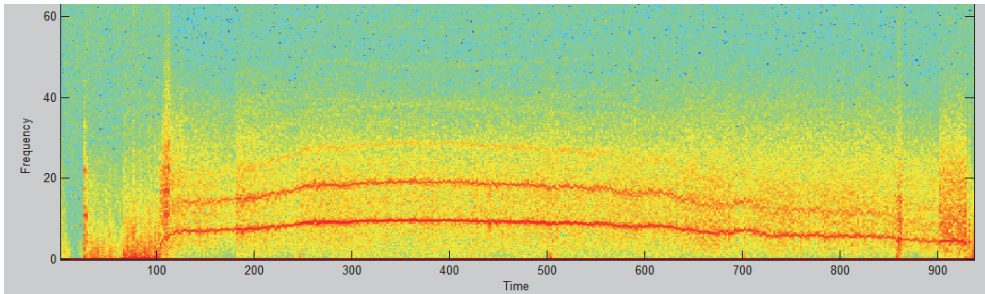

Fig. 20. Spectrogram of the entire experiment, which has a duration of approximately 15 minutes.

The more vertical and rapid the rise and fall of the analyzed signal, the more harmonic frequencies will be found along the vertical axis of the spectrogram. This means that the cibarial pump-associated muscles are receiving more electrical excitations and are working at higher intensity.

Figure 21 shows another experiment where the signal presents higher harmonic frequencies with greater amounts of energy.

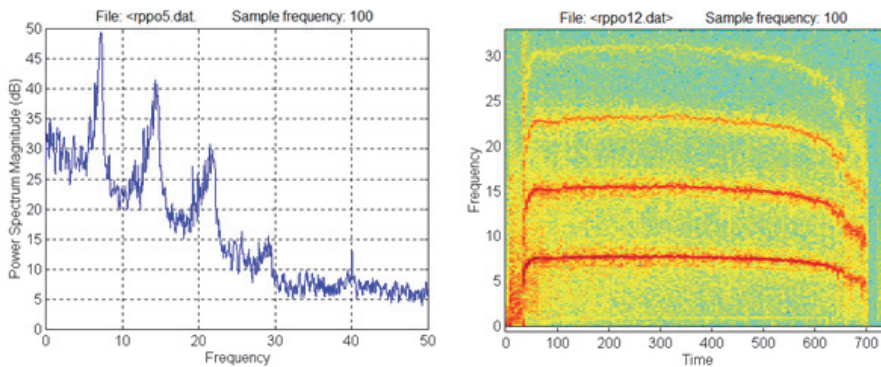

Fig. 21. Spectral content and spectrogram of a signal richer in harmonic frequencies.

6. Intravital microscopy of the cibarial pump and simultaneous recording of electrical signals

It is of paramount importance to confirm that the electrical signals shown above are indeed related to contraction of the cibarial pump muscles. This was done by means of experiments that record the electromyogram of the cibarial pump simultaneously with intravital microscopy of the cibarial pump. Images of the head of the bug during the feeding process were recorded using a digital camera connected to a stereomicroscope (Wild Heerbrug M5-89797). White light was directed onto the insect head to increase its transparency, facilitating observations of the cibarial pump in action. The images produced were analyzed using ImageJ software (Abramoff et al., 2004; Rasband, 2007). They were converted to 8 bits and the software used to calculate the dark area for each frame of the recorded videos (~25 frames/s). The values were transferred to Microsoft Excel and SigmaPlot 2002 for Windows Version 8.0 for analysis and graphic construction (Alves et al., 2011). Contrasting areas in the images (2D images) were measured during the feeding process for the area surrounding the cibarial pump in the head of the bug as an indicator of filling of the pump with blood, related to muscular contractions (Figure 22). Using this technique the chamber of an empty cibarial pump can easily be differentiated from the other structures of the insect head, whereas a blood-filled pump shows the same intensity as other structures of the head.

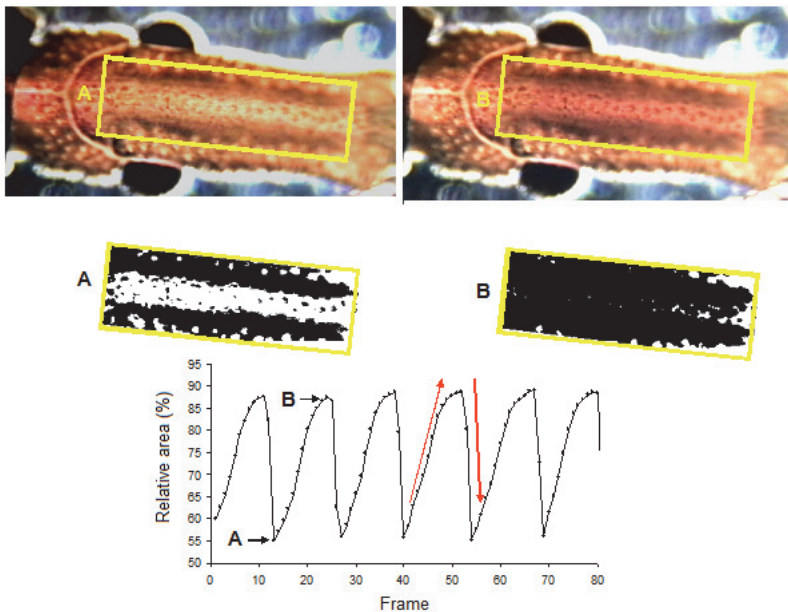

Fig. 22. Analyses of the cibarial pump images recorded by intravital microscopy of fifth instar of *Rhodnius prolixus* during blood feeding. Upper panel: Images with selected area (rectangle) indicating the cibarial pump when empty (A) or filled with blood (B). Lower panel: Images of the selected areas converted to 8 bits. The graph shows % variation in the area occupied by blood inside the cibarial pump over time (25 frames/second). Arrows indicate the region of the graph that represents the closing (A) and opening (B) of the pump.

When the graphs constructed from intravital microscopy of the insect head and the electromyogram of the cibarial pump are analyzed together, a strict synchrony can be observed between the electrical signals recorded and the filling of the pump chamber with blood (Figure 23) confirming that the electrical signals recorded are truly produced by cibarial pump-associated muscles.

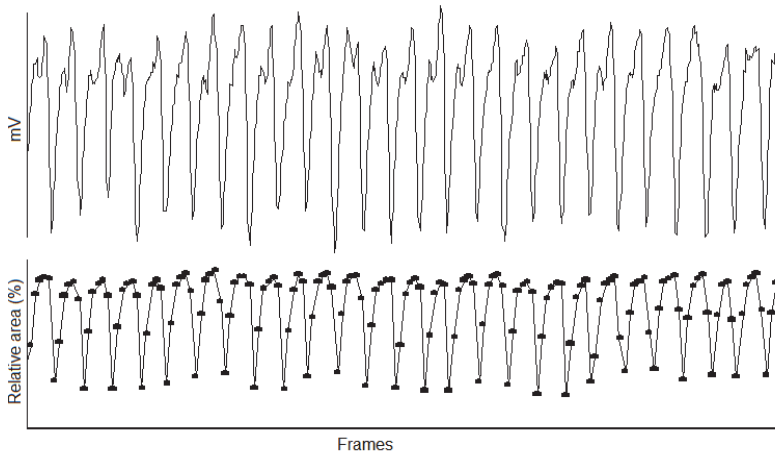

Fig. 23. Simultaneous monitoring of electrical activity (mV) and the flow of blood through the cibarial pump (relative area based on analyses of intravital microscopy images of the cibarial pump) of fifth instar nymphs of *Rhodnius prolixus* during the engorgement phase.

7. Profile of the signals produced during the feeding process and their meaning

The electrical signals produced by the cibarial pump can be selected and precisely monitored in such a way that the profiles obtained allowed delineation of each phase of the feeding process and calculation of the level of effort / difficulty in pumping blood. The signals detected before the bite show a somewhat regular profile with a small variation in mV (Figure 24). The bite is characterized by a sudden decrease in the mV, followed by a strong variation in mV characteristic of the probing phase (Figure 24). During the probing phase, some isolated, clearly formed signals can be seen, typical of those emitted by contractions of the cibarial pump. These isolated signals are attributed to “tasting” of the diet by the bug (Smith & Friend, 1970; Smith, 1979). It is assumed that during tasting, the insect ingests a sample for analysis by the gustatory sensilla, which can identify whether any of the vessel’s content is spread on the tissues due to increased permeability and extravasations of liquid.

Once a suitable vessel is found, probing ceases and the engorgement phase begins. This is characterized by a change in the signal profile from strong irregular variations of mV to variations with similar intensity and regular intervals presenting distinct, regularly distributed mV peaks (Figure 25). The engorgement phase is considered to have begun when a sequence of ten regular peaks is detected.

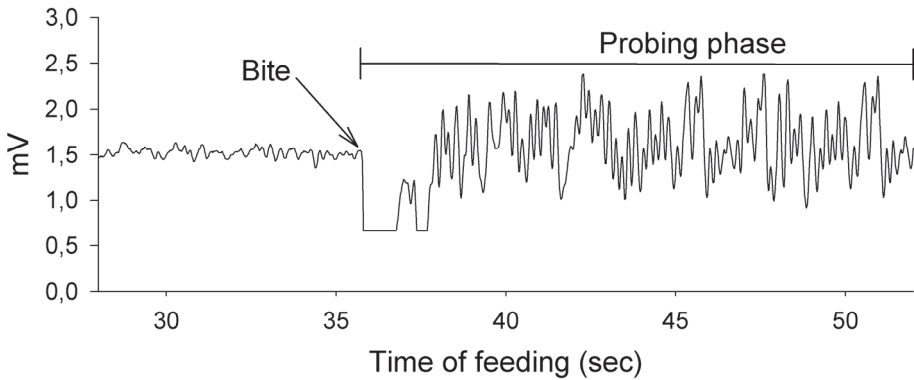

Fig. 24. Profiles observed before the bite and during the probing phase (modified from Araujo et al., 2009b).

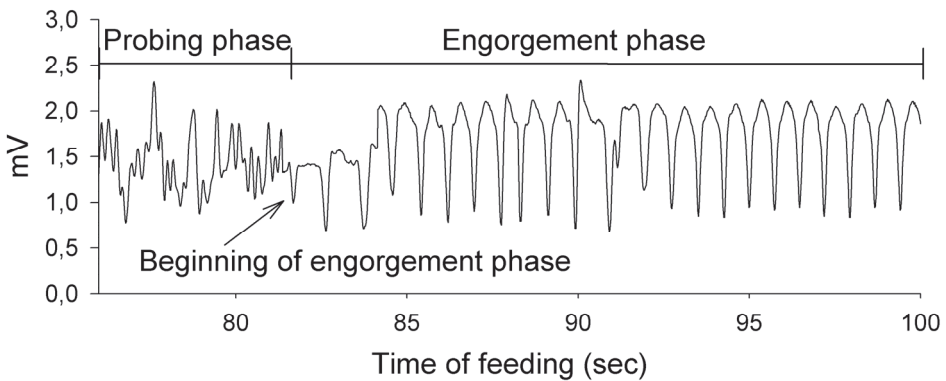

Fig. 25. Profiles observed during probing and beginning of the engorgement phase of *Cimex lectularius* feeding on mice (modified from Araujo et al., 2009b).

The engorgement phase can last from a few minutes (< 10 min) to more than one hour. The end of this phase is characterized by a sudden stop in the variation of the mV, resulting in a profile similar to the one seen before the bite, indicating that the insect has removed its mouthparts from the host (Figure 26).

The phases identified above can be added to other information to compose a set of important parameters used to study the feeding process. As well as noting the duration of blood-feeding, beginning of the engorgement phase and the end of the feeding process, the insects should be weighed before and after the observations in order to determine the weight gain (WG, defined as final minus initial weight). Based on the cibarial pump records, the total contact time (TCT) is defined as the time during which the insect mouthparts remain inserted into the host skin. Non-ingestive time (NIT) is the sum of the cumulative probing time (CPT) plus interruption time (IT). CPT is defined as the time from initial

insertion of the mouthparts into the host up to the beginning of the engorgement phase. If the insect ceases probing and resumes blood-feeding elsewhere, the first probing time is added to the second and so on. IT is defined as the time during which the insects are not pumping blood after the engorgement phase has begun. The quantity of liquid ingested per cibarial pump contraction (QLC) is obtained by dividing the WG by the total number of cibarial pump contractions during engorgement. Pump frequency (F) represents the total number of cibarial pump contractions divided by the functioning time of the cibarial pump. Ingestion rate (IR, mg/min) is calculated by multiplying QLC by F. The total number of bites (B) and the number of interruptions to feeding (I) during the whole process are also noted.

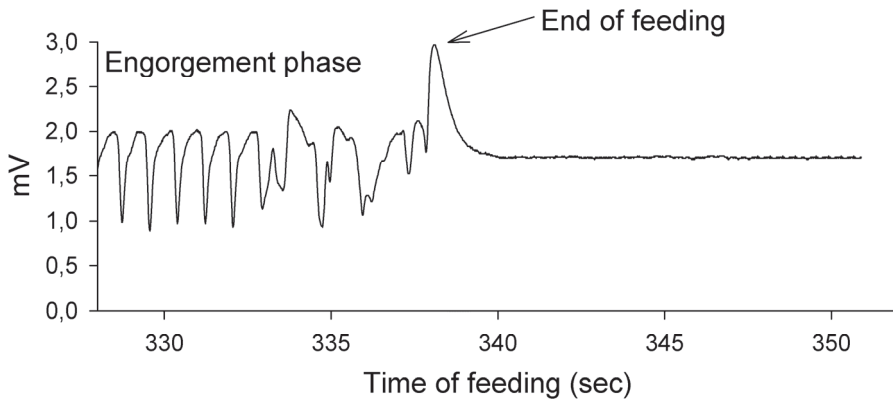

Fig. 26. Profiles observed at the end of the feeding of *Cimex lectularius* on mice showing the moment the mouthparts are removed from the host (modified from Araujo et al., 2009b).

The different profiles of the electrical signals can indicate other features that may be occurring during the engorgement phase. Parameters such as the negative pressure produced by the cibarial pump, dimensions of the food canal, blood viscosity, and the size of host red cells as well as their capacity to deform can influence both the ingestion rate (Kingsolver & Daniel, 1995) and the functioning of the cibarial pump. All these influences modify the profile of the electrical signals of the cibarial pump, reflect the performance of the bug during feeding and may indicate impediments to bloodmeal ingestion. An insect with high feeding performance shows electrical signals with regular peaks throughout the entire process (Figure 27a). Insects that impeded during feeding present a different electrical profile, in which the contractions are arrhythmic and the electrical signals have irregular shapes (duplicate peaks or intermediary forms between one or two peaks) (Figure 27b). The duplicate peaks seen in the cibarial pump contractions of bugs presenting difficulties in feeding may be explained by a lack of synchrony between the two bundles of the cibarial pump-associated muscles. These two electrical profiles can be seen at different moments in the same insect. Performance is usually higher at the onset of feeding, the electrical signal at the end, being disrupted, with a low pumping frequency.

A better overview of the whole feeding process is obtained using the matlab environment to analyze the profiles obtained by the electrical signals. The analyses facilitate the

identification of all the above parameters and the variation of the cibarial pump frequency during the engorgement phase can be seen more easily (Figure 28). Insects with good performance are able to keep the cibarial pump working at high frequencies (~4 - 5.5 Hz) during engorgement (Figure 28a). Insects with low performance usually are unable to keep the cibarial pump operating at high frequencies for more than the first third of the process, after which some problems are seen such as a reduction in the signal frequency, interruptions and irregular signals (seen as a blurred spectrum) (Figure 28b).

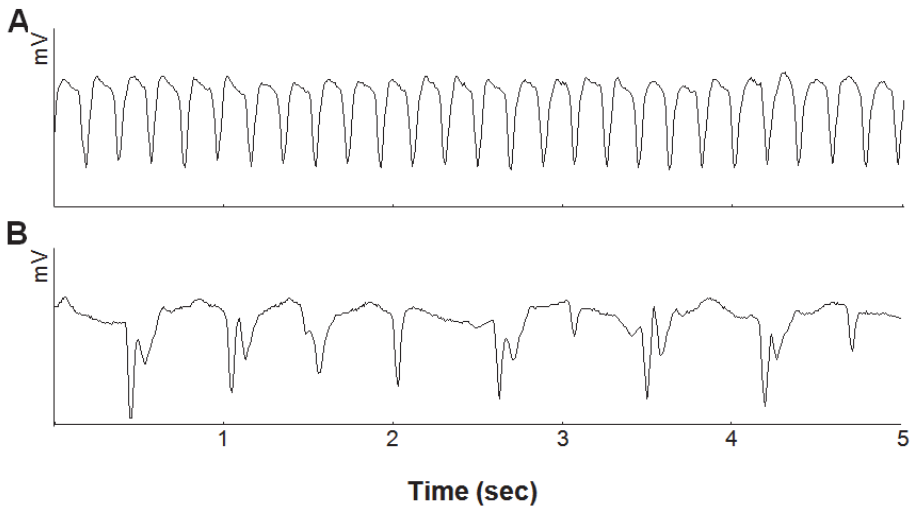

Fig. 27. Electrical profile of the engorgement phase from high (A) and low (B) performance feeding periods.

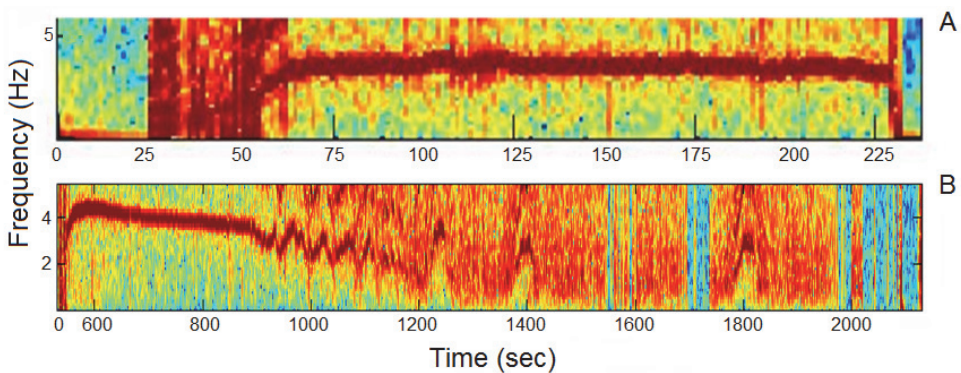

Fig. 28. General view of the whole feeding process of *Cimex lectularius* feeding on mice. A) high performance during the whole feeding process; B) low performance during the last two-thirds of engorgement.

8. Electromyogram studies of the cibarial pump

The analysis of feeding parameters based on cibarial pump electromyograms of different triatomine species feeding on pigeons, mice, humans or artificial feeders has provided sufficient information for us to know whether any differences were due the host type (Guarneri et al., 2000), triatomine species (Sant'Anna et al., 2001) or developmental stage (Guarneri et al., 2003) or to molecules produced in the salivary glands (Araujo et al., 2009a) or intestine (Araujo et al., 2007) of the insect. The QLC and maximum pumping frequency (obtained from experiments using artificial feeders) are related to the intrinsic morphological characteristics of the insect mouthparts. Based on the electrical signal methodology, several studies have demonstrated total ingestion rate (IR) to be the main parameter that determines contact time between a particular triatomine species and an immobilized host. IR values for fifth instar nymphs of the species studied to date vary from 3.1 mg/min for *R. neglectus* feeding on mice to 25.20 mg/min for *T. infestans* feeding on pigeons (Sant'Anna et al., 2001; Guarneri et al., 2000) (Table 1). The highest IR values for feeding on mice are observed for *T. infestans* (15.0 mg/min) and *R. prolixus* (11.9 mg/min) which are the most important vectors of *Trypanosoma cruzi* (etiological agent of Chagas' disease) in South and Central America, respectively (Guarneri et al., 2000; Sant'Anna et al., 2001). IR also varies considerably between different nymphal instars of the same species, for example, from 0.4 mg/min for first instars to 11.3 mg/min for fifth instars of *T. brasiliensis* feeding on humans (Guarneri et al., 2003). These differences in the IR observed during the post-embryonic development of triatomines are correlated to the QLC in the nymphal instar (Figure 30). It is noteworthy that males and females are sexually dimorphic with regard to cibarial pump volume. The higher QLC in females provides better performance than that seen in males, possibly an adaptation to increase their fitness in situations of higher competition.

Species	Pigeon	Mouse
<i>T. infestans</i> ^a	25.2 ± 6.0	15.0 ± 4.9
<i>T. brasiliensis</i> ^a	14.5 ± 5.6	10.8 ± 4.7
<i>T. pseudomaculata</i> ^a	5.0 ± 2.6	3.3 ± 0.9
<i>R. prolixus</i> ^b	19.5 ± 5.0	11.9 ± 3.8
<i>R. neglectus</i> ^b	5.7 ± 1.8	3.1 ± 1.6
<i>R. robustus</i> ^b	13.3 ± 6.2	7.4 ± 4.2
<i>R. nasutus</i> ^b	8.3 ± 3.9	8.5 ± 3.5

^a Guarneri, 1999; ^b Sant'Anna et al., 2001.

Table 1. Mean values and standard deviation of the ingestion rate (mg/min) for different triatomine species feeding on pigeon or mouse.

Unlike IR, parameters such as F and NIT are influenced by the host physiology. Most of the triatomine species feeding on mice have a lower F value than those feeding on pigeons, whereas NIT values are variable. However, except for *R. nasutus*, triatomines feeding on mice usually have a longer NIT (Sant'Anna et al., 2001). This might be related to haemostatic differences between birds and mammals. Birds have thrombocytes that perform a similar function to mammalian platelets but are less effective. They also seem to lack some coagulation factors, particularly in the intrinsic pathway (Lewis, 1996).

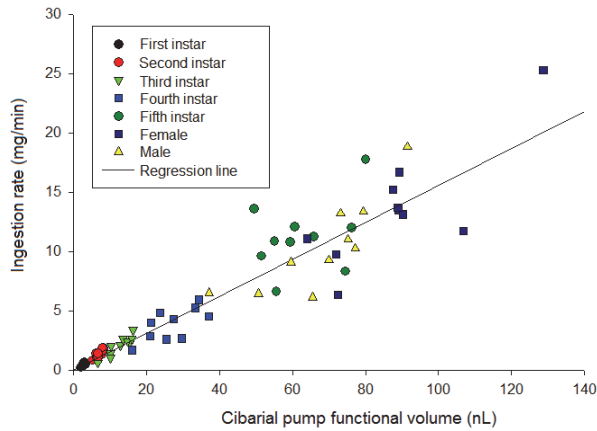

Fig. 29. Correlation between cibarial pump functional volume and ingestion rate of different developing instars of *Triatoma brasiliensis* feeding on humans.

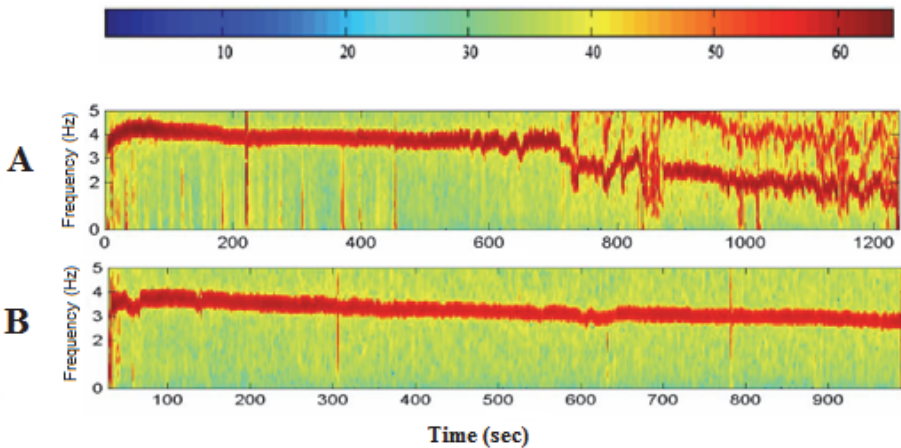

Fig. 30. Frequency spectrum over time produced by the cibarial pump contractions from *Triatoma brasiliensis* fed on the lateral tail vein of anesthetized mice. (A) *T. brasiliensis* feeding on non-treated mice; (B) *T. brasiliensis* feeding on mice treated with heparin. The colors represent the magnitude of occurrence of each frequency in the scale presented at the top of the figure.

Recent studies have shown that the coagulation process in the anterior midgut (crop) environment considerably influences feeding performance (Araujo et al., 2007; Paim et al., 2011). Insects that had their intestinal anticoagulant knocked down by RNA interference or by ingestion of exogenous thrombin had significantly lower total ingestion rate and weigh gain. The simplest explanation for the lower volumes ingested is that blood in the midgut must remain in a liquid state during feeding, or else backpressure induced by increased

viscosity will prevent successful pumping of blood into the midgut (Araujo et al., 2007). As confirmation of the importance of the intestinal anticoagulants, Paim et al. (2011) demonstrated that *T. brasiliensis* fails to maintain the cibarial pump frequency during the whole feeding process, even under the most favorable conditions (e.g. when feeding on large-caliber vessels). This difficulty disappears when the host is previously treated with a systemic anticoagulant (Figure 29).

9. References

- Abramoff, M.D., Magalhaes, P.J. & Ram, S.J. (2004). Image processing with ImageJ. *Biophot Int*, Vol. 11, pp. (36-42).
- Alves, C.L., Araujo, R.N., Gontijo, N.F. & Pereira, M.H. (2011). Importance and physiological effects of hemolymphagy in triatomines (Hemiptera: Reduviidae). *J Med Entomol*, Vol. 48, pp. (372-381).
- Araujo, R.N., Soares, A.C., Paim, R.M., Gontijo, N.F., Gontijo, A.F., Lehane, M.J. & Pereira, M.H. (2009a). The role of salivary nitrophorins in the ingestion of blood by the triatomine bug *Rhodnius prolixus* (Reduviidae: Triatominae). *Insect Biochem Mol Biol*, Vol. 39, pp. (83-89).
- Araujo, R.N., Costa, F.S., Gontijo, N.F., Gonçalves, T.C.M. & Pereira, M.H. (2009b). The feeding process of *Cimex lectularius* (Linnaeus 1758) and *Cimex hemipterus* (Fabricius 1803) on different bloodmeal sources. *J Insect Physiol*, Vol. 55, pp. (1151-1157).
- Backus, E.A. & McLean, D.L. (1982). The sensory systems and feeding behavior of leafhoppers. I. The aster leafhopper, *Macrosteles fascifrons* Stål (Homoptera: Cicadellidae). *J Morphol*, Vol. 172, pp. (361-379).
- Bennet-Clark, H.C. (1963). Negative pressures produced in the cibarial pump of the blood sucking bug *Rhodnius prolixus*. *J Exp Biol*, Vol. 40, pp. (223-229).
- Dickerson, G. & Lavoipierre, M.M. (1959). Studies on the methods of feeding of bloodsucking arthropods. II. The method of feeding adopted by the bed-bug (*Cimex lectularius*) when obtaining a blood-meal from the mammalian host. *Ann Trop Med Parasitol*, Vol. 53, pp. (347-357).
- Gordon, R.M. & Crewe, W. (1948). The mechanisms by which mosquitoes and tsetse-flies obtain their blood-meal, the histology of the lesions produced, and the subsequent reactions of the mammalian host; together with some observations on the feeding of *Chrysops* and *Cimex*. *Ann Trop Med Parasitol*, Vol. 42, pp. (334-356).
- Guarneri, A.A. (1999). Influência da fonte alimentar no potencial biológico de triatomíneos. Master's dissertation, Universidade Federal de Minas Gerais, Belo Horizonte, Brazil.
- Guarneri, A.A., Diotaiuti, L., Gontijo, N.F., Gontijo, A.F. & Pereira, M.H. (2000). Comparison of feeding behaviour of *Triatoma infestans*, *Triatoma brasiliensis* and *Triatoma pseudomaculata* in different hosts by electronic monitoring of the cibarial pump. *J Insect Physiol*, Vol. 46, pp. (1121-1127).
- Guarneri, A.A., Diotaiuti, L., Gontijo, N.F., Gontijo, A.F. & Pereira, M.H. (2003). Bloodfeeding performance of nymphs and adults of *Triatoma brasiliensis* on human hosts. *Acta Trop*, Vol. 87, pp. (361-370).
- Kingsolver, J.G. & Daniel, T.L. (1995). Mechanics of food handling by fluid-feeding insects. In *Regulatory Mechanisms in Insect Feeding* (Chapman, R.F. and De Boer, G., eds), pp. 32-73, Chapman & Hall.

- Lavoipierre, M.M.J., Dickerson, G. & Gordon, R.M. (1959). Studies on the methods of feeding of blood-sucking arthropods. I – The manner in which triatomine bugs obtain their blood-meal, as observed in the tissues of the living rodent, with some remarks on the effects of the bite on human volunteers. *Ann Trop Med Parasitol*, Vol. 53, pp. (235–252).
- Lewis, J.H. (1996). *Comparative hemostasis in vertebrates*. Plenum Press, New York.
- MathWorks (1995) *Simulink(TM), Dynamic System Simulation Software*, The MathWorks Inc., Natick, MA, USA.
- McLean, D.L. & Kinsey, M.G. (1964). A technique for electrically recording aphid feeding and salivation. *Nature*, Vol. 202, pp. (1358-1359).
- Paim, R.M., Araújo, R.N., Soares, A.C., Lemos, L.C., Tanaka, A.S., Gontijo, N.F., Lehane, M.J. & Pereira, M.H. (2011). Influence of the intestinal anticoagulant in the feeding performance of triatomine bugs (Hemiptera; Reduviidae). *Int J Parasitol*, Vol. 39, pp. (83-89).
- Pérez, J.R. (1969). Estudio sobre la anatomía de *Rhodnius prolixus*. *Rev Venez Sanid Assist Soc*, Vol. 34, pp. (10-98).
- Rasband, W.S., ImageJ, U. S. National Institutes of Health, Bethesda, Maryland, USA. <http://imagej.nih.gov/ij/>, 1997-2011.
- Prutchi, D. & Norris, M. (2005). *Design and Development of Medical Electronic Instrumentation: A Practical Perspective of the Design, Construction, and Test of Medical Devices*, John Wiley & Sons Inc, Hoboken, New Jersey.
- Sant'Anna, M.R.V., Diotaiuti, L., Gontijo, A.F., Gontijo, N.F. & Pereira, M.H. (2001). Feeding behaviour of morphologically similar *Rhodnius* species: influence of medical characteristics and salivary function. *J Insect Physiol*. Vol. 47, pp. (1459-1465).
- Schofield, C.J. (1994). *Triatominae: Biología y control*. Eurocommunica Publications, West Sussex.
- Schofield, C.J. (1995). Overview - Biosystematics of the Reduviidae. *Proceedings of International Workshop on Population Genetics and Control of Triatominae*, Santo Domingo de los Colorados, Ecuador, 1995, Sep. 24-28.
- Schofield, C. J. & Dolling, W. R. (1996). Bedbugs and kissing-bugs (bloodsucking Hemiptera). In: *Medical Insects and Arachnids*, Lane, R. P. & Crosskey, R. W., pp. (483-516), Chapman & Hall, London.
- Smith, J.J.B. (1979). Effect of diet viscosity on the operation of the pharyngeal pump in the blood-feeding bug *Rhodnius prolixus*. *J Exp Biol*, Vol. 82, pp. (93-104).
- Smith, J.J.B. & Friend, W.G. (1970). Feeding in *Rhodnius prolixus*: responses to artificial diets as revealed by changes in electrical resistance. *J Insect Physiol*, Vol. 16, pp. (1709-1720).
- Snodgrass, R.E. (1935). *Principles of insect morphology*. MacGraw-Hill Book Company Inc., 667 pp. (319) Figs. New York.
- Snodgrass, R.E. (1944). The anatomy of the Mallophaga. *Occas Papers Cal Acad Sci*, Vol. 6, pp. (145-229).
- Soares, A.C., Carvalho-Tavares, J., Gontijo, N.de.F., dos Santos, V.C., Teixeira, M.M. & Pereira, M.H. (2006). Salivation pattern of *Rhodnius prolixus* (Reduviidae; Triatominae) in mouse skin. *J Insect Physiol*, Vol. 52, pp. (468-472).
- Tjallingii, W.F. (1985). Electrical nature of recorded signals during stylet penetration by aphids. *Entomol Exp Appl*, Vol. 38, pp. (177-186).
- Usinger, R.L. (1966). *Monograph of Cimicidae*, Vol. 7. The Thomas Say Foundation, Baltimore.