

Transmission of Numeric Data and Voice Using Light Fidelity (LIFI) Technology

Dr. Naveen Rathee^{*}, Abhinav Malik^{#1}, Shreyaa Nagpal^{#2}

^{*}Department of Electronics and Communication, Bhagwan Parshuram Institute of Technology, Sector-17 Rohini, Delhi, India

[#]Bachelor of Technology, Bhagwan Parshuram Institute of Technology, Rohini, Delhi, India

Abstract: LIFI is a field of research which has to cover several miles in each and every phase to prove its efficacy as a potent technology that holds the strength to challenge the wide ranging technology today. Be it the radio spectrum which has continued to aggrandize and proliferate with times bringing in a high competition. But LIFI stands among the technology by proving itself innocuous, non-hazardous, and easy to use. A simple experiment to show the transmission of sound and numeric data (0-9, *, #) using visible light communication is performed. The DTMF toner and a microphone are used as an input selectively through a multi way switch and a speaker and an LCD display are used as outputting device. The medium which binds the transmitter end to the receiver end is an LED source or the visible light communication.

Keywords: Light Fidelity, LIFI, Visible Light Communication, VLC, WIFI, Microcontroller, DTMF, Microphone, LCD, LED.

I. INTRODUCTION

A 5G technology as they say, LIFI is coined as a massive MIMO visible light communication network which uses LEDs[1].

A future technology that guarantees to replace the 2G, 2.5G, 3G and the latest 4G systems of communication. The current technologies which employ WIFI defines it as any "wireless local area network (WLAN) products that are based on the Institute of Electrical and Electronics Engineers' (IEEE) 802.11 standards"[2]. LIFI is thought of as an alternative or an exchange to the currently used WIFI. With an exhausted and congested network, it was necessary to articulate our minds into a technology which not only is ubiquitous but also a resourceful quantity. Professor Harald Haas during his TED global talk rightfully coined LIFI as the future upcoming technology[3].

Quiet significant amounts of advantages make LIFI a potent technology. Visible light is defined as having a wavelength in range of 400 nanometers to 700 nanometers, which pros to have 10,000 times broader spectrum than the radio wave spectrum employed in WIFI[4]. This technology further has the quintessential advantage of not needing any base stations and primarily requiring unlicensed services. Very high data rates can be achieved due to low interference, high device bandwidths and high intensity optical output[5]. Moreover, it is non-hazardous and a safe technology which can even be employed in riverbeds and is cost effective. These pros of LIFI outshine it from other technologies.

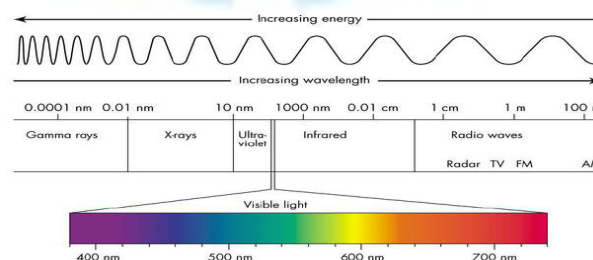

Figure 1: Visible light spectrum used for LIFI technology

II. PRINCIPLE OF LIFI TECHNOLOGY

LIFI technology works on a very simple principle as a digital system does. With a high speed variation in the amplitude of light, transmission of data takes place through illumination[6]. The data is converted into binary forms of '1' indicating the LED is on and '0' to posit that the LED is off [7]. The LED is installed with a microchip to manage the variation in illumination which is at a speed invisible to human eye. A photo detector at the receiver detects the photo using a photo sensitive device installed. This send the further information to the display tool attached decoding the data back into its original form[8].

International Journal for Research in Applied Science & Engineering Technology(IJRASET)



Figure2: Transmission of data in binary form

III. LIFI COMMUNICATION

The IEEE 802 workgroup has suffice potential to transmit media, video, audio files. With the similar protocol as TCP/IP, LIFI defines the usage of two layers for its model, the physical layer (PHY) and the media access layer (MAC). MAC layer is used as a link to the other layers whereas the PHY layer is categorized into further 3 PHY layers based on their rates.

- *PHY I*- 11.67kbps to 267.6 kbps (for outdoor application)
- *PHY II*- 1.25 mbps to 96 mbps (reaching data)
- *PHY III*- 12 mbps to 96 mbps (emitting sources)

The modulation technique for the first two physical layers identifies the use of OOK (on –off keying) or BASK (base amplitude shift keying) and a variable pulse position modulation (VPPM) [9]

IV. SYSTEM DESIGN AND WORKING

A. Working Of Transmitter Board

A 4X3 matrix keypad is taken that transmits numeric data from 0-9,*,#. It is interfaced with keypad driver IC 91214 b which is also known as DTMF tone generator. Each key has a different frequency that is made up of two frequencies one from low tone group from 697 Hz-941 Hz, and the other from high tone group from 1209 Hz-1477 Hz. The tone generated is a DTMF frequency which is converted from digital to analog form by this IC. The output of this IC is fed to the op amp 741c to prevent signal losses. This IC is further connected to push pull amplifiers. A two way switch is provided to select keypad or a microphone. If the switch is on, microphone is selected else the keypad is selected. A variable resistance is provided to adjust the amplification and sound of the speaker. At the output of the transistors a torch is connected to convert analog signals into light form. While on the other hand microphone converts sound to analog form.

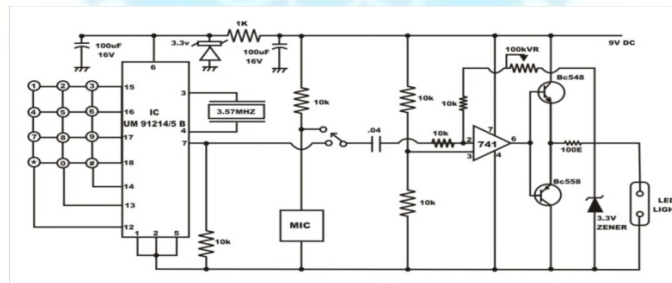

Figure 3: TRANSMITTER CIRCUIT

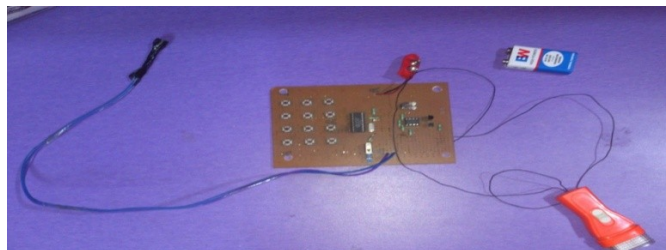

Figure 4: PRACTICAL IMPLEMENTATION

International Journal for Research in Applied Science & Engineering Technology(IJRASET)

B. Working of Receiver Circuit

The signal received in the light form is detected by the photodiode which converts the light signal to analog form. The photodiode is connected to the op-amp to reduce distortion losses. The output of the op-amp is connected to the IC MT8870 which a DTMF receiver. Also the output of op-amp is connected to the speaker to convert output analog signal to sound form. IC MT 8870 converts the analog signal to digital form and understands the frequency received and converts it into 4-bit BCD form for displaying on 16x2 LCD. Microcontroller ATMEGA8L is used to interface LCD and DTMF receiver. ATMEGA8L takes the BCD input from the DTMF receiver and displays it on the 16x2 LCD. IC 7805 is used, which is a voltage regulator that steps down 8V supply to 5V for the working of circuit.

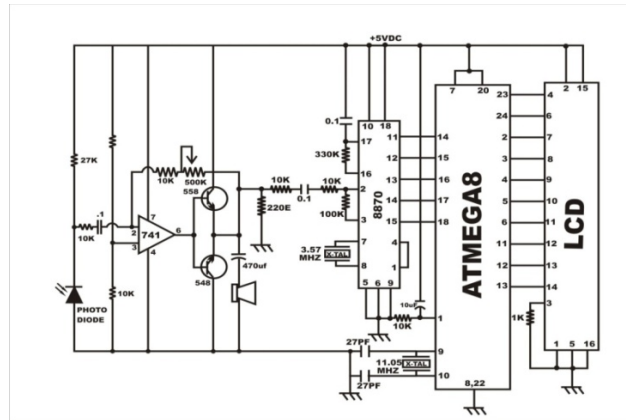

Figure 5: RECIEVER CIRCUIT

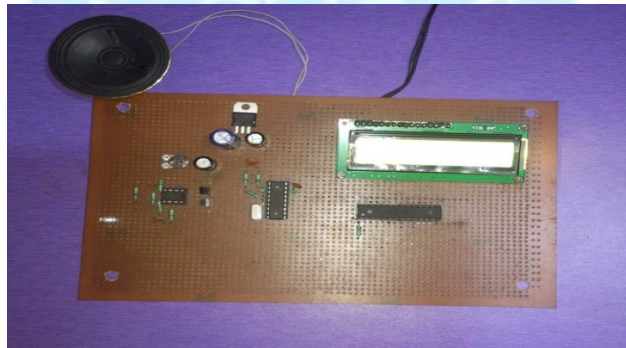

Figure 6: PRACTICAL IMPLEMENTATION

SYSTEM MODEL

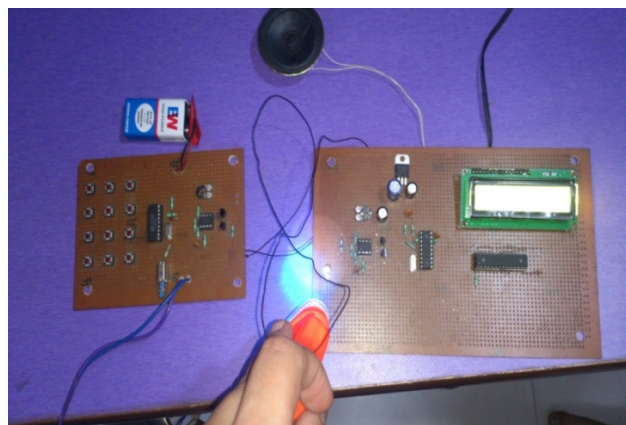

Figure 7:OVERALL SYSTEM

International Journal for Research in Applied Science & Engineering Technology(IJRASET)

The figure above shows both the transmitter and receiver circuit being communicated using a light source that is an LED. Numeric data and audio communication is possible through this circuit using visible light communication. The LCD displays the output of the numeric matrix keypad. When a microphone is used to transmit the audio then speaker gives the output.

V. OBSERVATIONS

PARAMETERS	OBSERVATION
Height at which the source can be kept for LIFI communication to take place	Minimum height : 7 cm Maximum height : 75 cm
Light allowance	Data transmission occurs at every LED light that has a microcontroller operation attached with it.
Temperature range	0 - 70 Degree Celsius
Variation with Intensity	Intensity of light doesn't hamper the transmission of data. The data is transmitted even when the light is cold, dull and less intense.

Table 1: Observations of research

VI. RESULT

LIFI communication technology on which we have worked uses light frequencies rather than the usual radio waves. Embedded with a microchip that produces a signal, the LED yields rates much faster than the usual internet connection speed we have.

The digital input given by the matrix keypad is sent to DTMF transmitter that changes it from digital to analog signals to transmit it further. The photodiode present on the receiver circuit detects the light made to fall on it using led torch, the signal hence generated is made to pass through DTMF tone receiver that converts it from analog to digital signal. The receiver circuit has ATMEGA8L microcontroller that is interfaced with LCD to display data. The circuit also has a microphone and a speaker for the communication of audio signals.

VII. APPLICATIONS

LIFI, with its manifested applications, is a safe and secure form of data transmission when a proper path is provided for its communication as compared to radio frequency transmission. LIFI technology finds its use in petrochemical industry where a radio spectrum usage may prove to be deadly. Airplanes also find LIFI as main source since radio waves might hamper the whole system. Hospitals particularly mention the usage of phones and radio wave connections to be abandoned and this LIFI technology will work wonders when used here. Military and navigation operations where radio frequencies cannot be used reliably as they create problems, LIFI stands out and works out best. Moreover, installation of microchips in street lights can also act as free access point for the purpose of data communication as it is mostly available everywhere.

VIII. FUTURE SCOPE

LIFI is expected to be ten times cheaper than Wi-Fi. The light waves cannot penetrate walls which makes a much shorter range, though more secure from hacking, relative to Wi-Fi. While the US Federal Communications Commission has warned of a potential spectrum crisis because Wi-Fi is close to full capacity, LIFI has almost no limitations on capacity. The visible light spectrum is 10,000 times larger than the entire radiofrequency spectrum. Researchers have reached data rates of 3.5 Gbps and have set a goal of reaching data rates up to 6 Gbps. The LIFI market is researched to be worth over \$6 billion per year by 2018. Low reliability and high installation costs are the potential drawbacks.

International Journal for Research in Applied Science & Engineering Technology(IJRASET)

IX. CONCLUSION

Our research deals with designing a simple and low cost data communication system using LED, DTMF transmitter and receiver, LCD, ATMEGA8L microcontroller unit that transmits numeric data and also helps in audio communication. The circuit module is designed at the preliminary stage that reads numeric data and special characters * ,# and makes audio communication possible but it can be enhanced further to read alpha-numeric data as well as to enable video communication using camera or some digital device.

The possibilities are numerous and can be explored further. If this technology can be put into practical use, every bulb can be used something like a Wi-Fi hotspot to transmit wireless data and we can proceed towards the cleaner, greener, safer and brighter future. The concept of LIFI is currently attracting a great deal of interest, because it may offer a genuine and very efficient alternative to radio-based wireless. As a growing number of people and their many devices access wireless internet, the airwaves are becoming increasingly clogged, making it more and more difficult to get a reliable, high-speed signal. This may solve issues such as the shortage of radio-frequency bandwidth and also allow internet where traditional radio based wireless isn't allowed such as aircraft or hospitals. However one of the shortcomings is that it only works in the direct line of sight.

REFERENCES

- [1] National Instruments and the University of Edinburgh Collaborate on Massive MIMO Visible Light Communication Networks to Advance 5G , Cambridge Wireless, 20 November 2013.
- [2] What is Wi-Fi? – A Word Definition from the Webopedia Computer Dictionary.
- [3] http://www.ted.com/talks/harald_haas_wireless_data_from_every_light_bulb
- [4] Pal, G. K.; Pal, Pravati (2001). "chapter 52". *Textbook of Practical Physiology* (1st ed.). Chennai: Orient Blackswan. p. 387. ISBN 978-81-250-2021-9. Retrieved 11 October 2013.
- [5] http://purelifi.com/what_is_li-fi/li-fi-features/
- [6] www.lificonsortium.org.
- [7] <http://beyondweblogs.com/what-is-li-fi-is-this-replacing-Wi-Fi/> .
- [8] <http://heightech.blogspot.in/2012/10/lifi-latest-technology-in-wireless.html>, October 2012.
- [9] JM.ThanigavelM .Tech CSE DEPT, GKCE, Sullerpet, AP, India-IJERTV21S10048

