

World Journal of *Gastroenterology*

World J Gastroenterol 2014 December 14; 20(46): 17265-17692



**TOPIC HIGHLIGHT**

- 17265 Health care-associated hepatitis C virus infection
Pozzetto B, Memmi M, Garraud O, Roblin X, Berthelot P
- 17279 Locally advanced rectal cancer: The importance of a multidisciplinary approach
Berardi R, Maccaroni E, Onofri A, Morgese F, Torniai M, Tiberi M, Ferrini C, Cascinu S
- 17288 Early-onset colorectal cancer: A separate subset of colorectal cancer
Osorio Silla I, Rueda D, Rodríguez Y, García JL, Cruz Vigo F, Perea J
- 17297 Current status of function-preserving surgery for gastric cancer
Saito T, Kurokawa Y, Takiguchi S, Mori M, Doki Y
- 17305 Alternative splicing of DNA damage response genes and gastrointestinal cancers
Rahmutulla B, Matsushita K, Nomura F
- 17314 Genetic and phenotypic heterogeneity in tropical calcific pancreatitis
Paliwal S, Bhaskar S, Chandak GR
- 17324 Oxidative stress and inflammatory signaling in cerulein pancreatitis
Yu JH, Kim H
- 17330 Video capsule endoscopy: Perspectives of a revolutionary technique
Bouchard S, Ibrahim M, Van Gossum A

REVIEW

- 17345 Computed tomography perfusion imaging as a potential imaging biomarker of colorectal cancer
Hayano K, Fujishiro T, Sahani DV, Satoh A, Aoyagi T, Ohira G, Tochigi T, Matsubara H, Shuto K
- 17352 Anti-tumour necrosis factor agent and liver injury: Literature review, recommendations for management
Rossi RE, Parisi I, Despott EJ, Burroughs AK, O'Beirne J, Conte D, Hamilton MI, Murray CD

17360 Hepatitis B and human immunodeficiency virus co-infection

Phung BC, Sogni P, Launay O

17368 Hematopoietic stem cell transplantation for non-malignant gastrointestinal diseases

Al-toma A, Nijeboer P, Bouma G, Visser O, Mulder CJJ

ORIGINAL ARTICLE

17376 Pea3 expression promotes the invasive and metastatic potential of colorectal carcinoma

Mesci A, Taeb S, Huang X, Jairath R, Sivaloganathan D, Liu SK

17388 Epidemiology of upper gastrointestinal symptoms in Brazil (EpiGastro): A population-based study according to sex and age group

Rosário Dias de Oliveira Latorre M, Medeiros da Silva A, Chinzon D, Eisig JN, Dias-Bastos TRP

17399 Hybrid bioartificial liver support in cynomolgus monkeys with D-galactosamine-induced acute liver failure

Zhang Z, Zhao YC, Cheng Y, Jian GD, Pan MX, Gao Y

RESEARCH REPORT

17407 Hepatoprotective effect of nitric oxide in experimental model of acute hepatic failure

Saracyn M, Brytan M, Zdanowski R, Ząbkowski T, Dyrła P, Patera J, Wojtuń S, Kozłowski W, Wańkiewicz Z

17416 T₃-induced liver AMP-activated protein kinase signaling: Redox dependency and upregulation of downstream targets

Videla LA, Fernández V, Cornejo P, Vargas R, Morales P, Ceballo J, Fischer A, Escudero N, Escobar O

17426 Lobaplatin inhibits growth of gastric cancer cells by inducing apoptosis

Yin CY, Lin XL, Tian L, Ye M, Yang XY, Xiao XY

17434 Oesophageal flap valvuloplasty and wrapping suturing prevent gastroesophageal reflux disease in dogs after oesophageal anastomosis

Dai JG, Liu QX, Den XF, Min JX

17439 miR-374b-5p suppresses RECK expression and promotes gastric cancer cell invasion and metastasis

Xie J, Tan ZH, Tang X, Mo MS, Liu YP, Gan RL, Li Y, Zhang L, Li GQ

**EVIDENCE-BASED
 MEDICINE**

17448 Pancreaticoduodenectomy with vascular reconstruction for adenocarcinoma of the pancreas with borderline resectability
Cheung TT, Poon RTP, Chok KSH, Chan ACY, Tsang SHY, Dai WC, Chan SC, Fan ST, Lo CM

CASE CONTROL STUDY

17456 Case-control study of diabetes-related genetic variants and pancreatic cancer risk in Japan
Kuruma S, Egawa N, Kurata M, Honda G, Kamisawa T, Ueda J, Ishii H, Ueno M, Nakao H, Mori M, Matsuo K, Hosono S, Ohkawa S, Wakai K, Nakamura K, Tamakoshi A, Nojima M, Takahashi M, Shimada K, Nishiyama T, Kikuchi S, Lin Y

RETROSPECTIVE STUDY

17463 Extraintestinal manifestations in a large series of Italian inflammatory bowel disease patients
Zippi M, Corrado C, Pica R, Avallone EV, Cassieri C, De Nitto D, Paoluzi P, Vernia P

17468 Outcome of endotherapy for pancreas divisum in patients with acute recurrent pancreatitis
Mariani A, Di Leo M, Petrone MC, Arcidiacono PG, Giussani A, Zupardo RA, Cavestro GM, Testoni PA

17476 Verification of gene expression profiles for colorectal cancer using 12 internet public microarray datasets
Chang YT, Yao CT, Su SL, Chou YC, Chu CM, Huang CS, Terng HJ, Chou HL, Wetter T, Chen KH, Chang CW, Shih YW, Lai CH

17483 Prognostic factors for survival after transarterial chemoembolization combined with microwave ablation for hepatocellular carcinoma
Ni JY, Sun HL, Chen YT, Luo JH, Chen D, Jiang XY, Xu LF

17491 Analysis of risk factors for postoperative pancreatic fistula following pancreaticoduodenectomy
Liu QY, Zhang WZ, Xia HT, Leng JJ, Wan T, Liang B, Yang T, Dong JH

CLINICAL TRIALS STUDY

17498 Genomic landscape of pancreatic neuroendocrine tumors
Gebauer N, Schmidt-Werthern C, Bernard V, Feller AC, Keck T, Begum N, Rades D, Lehnert H, Brabant G, Thorns C

OBSERVATIONAL STUDY

17507 Endoscopic non-technical skills team training: The next step in quality assurance of endoscopy training
Matharoo M, Haycock A, Sevdalis N, Thomas-Gibson S

- 17516** Cytokine production in patients with cirrhosis and *TLR4* polymorphisms
Nieto JC, Sánchez E, Román E, Vidal S, Oliva L, Guarner-Argente C, Poca M, Torras X, Juárez C, Guarner C, Soriano G
- 17525** Clinical epidemiology of ulcerative colitis in Arabs based on the Montréal classification
Alharbi OR, Azzam NA, Almalki AS, Almadi MA, Alswat KA, Sadaf N, Aljebreen AM
- 17532** Plasma cathepsin L: A prognostic marker for pancreatic cancer
Singh N, Das P, Gupta S, Sachdev V, Srivasatava S, Datta Gupta S, Pandey RM, Sahni P, Chauhan SS, Saraya A
- 17541** Significance of downregulation of liver fatty acid-binding protein in hepatocellular carcinoma
Inoue M, Takahashi Y, Fujii T, Kitagawa M, Fukusato T
- 17552** Laterally spreading tumors: Limitations of computed tomography colonography
Togashi K, Utano K, Kijima S, Sato Y, Horie H, Sunada K, Lefor AT, Sugimoto H, Yasuda Y
- 17558** Three-Tesla magnetic resonance elastography for hepatic fibrosis: Comparison with diffusion-weighted imaging and gadoxetic acid-enhanced magnetic resonance imaging
Park HS, Kim YJ, Yu MH, Choe WH, Jung SI, Jeon HJ

PROSPECTIVE STUDY

- 17568** Upper-gastrointestinal bleeding secondary to peptic ulcer disease: Incidence and outcomes
Quan S, Frolkis A, Milne K, Molodecky N, Yang H, Dixon E, Ball CG, Myers RP, Ghosh S, Hilsden R, van Zanten SV, Kaplan GG
- 17578** Introducing an enhanced recovery after surgery program in colorectal surgery: A single center experience
Bona S, Molteni M, Rosati R, Elmore U, Bagnoli P, Monzani R, Caravaca M, Montorsi M
- 17588** Prevalence, histologic and clinical characteristics of heterotopic gastric mucosa in Chinese patients
Fang Y, Chen L, Chen DF, Ren WY, Shen CF, Xu Y, Xia YJ, Li JW, Wang P, Zhang AR, Shao SZ, Yu XN, Peng GY, Fang DC

SYSTEMATIC REVIEWS

- 17595** Costs of laparoscopic and open liver and pancreatic resection: A systematic review
Limongelli P, Vitiello C, Belli A, Pai M, Tolone S, del Genio G, Bruscianno L, Docimo G, Habib N, Belli G, Jiao LR, Docimo L
- 17603** Effects of laparoscopic cholecystectomy on lung function: A systematic review
Bablekos GD, Michaelides SA, Analitis A, Charalabopoulos KA
- 17618** Epidemiology of *Helicobacter pylori* infection among the healthy population in Iran and countries of the Eastern Mediterranean Region: A systematic review of prevalence and risk factors
Eshraghian A

META-ANALYSIS

- 17626** Meta-analysis of laparoscopic vs open cholecystectomy in elderly patients
Antonίου SA, Antonίου GA, Koch OO, Pointner R, Granderath FA
- 17635** *Helicobacter pylori* infection and atopic diseases: Is there a relationship? A systematic review and meta-analysis.
Lionetti E, Leonardi S, Lanzafame A, Garozzo MT, Filippelli M, Tomarchio S, Ferrara V, Salpietro C, Pulvirenti A, Francavilla R, Catassi C
- 17648** Is concomitant radiotherapy necessary with gemcitabine-based chemotherapy in pancreatic cancer?
Zhang X, Huang HJ, Feng D, Yang DJ, Wang CM, Cai QP

CASE REPORT

- 17656** Late onset fulminant Wilson's disease: A case report and review of the literature
Weitzman E, Pappo O, Weiss P, Frydman M, Haviv-Yadid Y, Ben Ari Z
- 17661** Rare combination of familial adenomatous polyposis and gallbladder polyps
Mori Y, Sato N, Matayoshi N, Tamura T, Minagawa N, Shibao K, Higure A, Nakamoto M, Taguchi M, Yamaguchi K
- 17666** Hirschsprung's disease in twin to twin transfusion syndrome: A case report
Park HW, Cho MJ, Kim WY, Kwak BO, Kim MH
- 17670** Emergency laparoscopic partial splenectomy for ruptured spleen: A case report
Cai YQ, Li CL, Zhang H, Wang X, Peng B

17674 Focal autoimmune pancreatitis and chronic sclerosing sialadenitis mimicking pancreatic cancer and neck metastasis

Sun L, Zhou Q, Brigstock DR, Yan S, Xiu M, Piao RL, Gao YH, Gao RP

17680 Sclerosing cholangitis secondary to bleomycin-iodinated embolization for liver hemangioma

Jin S, Sun XD, Shi XJ, Wang SY, Wang GY

LETTERS TO THE EDITOR 17686 Reversal of IgM deficiency following a gluten-free diet in seronegative celiac disease

Montenegro L, Piscitelli D, Giorgio F, Covelli C, Fiore MG, Losurdo G, Iannone A, Ierardi E, Di Leo A, Principi M

17690 Diagnostically untypable hepatitis C virus variants: It is time to resolve the problem

Afzal MS, Khan MY, Ammar M, Anjum S, Zaidi NSS

APPENDIX I-VI Instructions to authors

ABOUT COVER Editorial Board Member of *World Journal of Gastroenterology*, Daniel E Freedberg, MD, Academic Fellow, Division of Digestive and Liver Diseases, Department of Medicine, Columbia University, College of Physicians and Surgeons, New York, NY 10032, United States

AIMS AND SCOPE *World Journal of Gastroenterology* (*World J Gastroenterol*, *WJG*, print ISSN 1007-9327, online ISSN 2219-2840, DOI: 10.3748) is a peer-reviewed open access journal. *WJG* was established on October 1, 1995. It is published weekly on the 7th, 14th, 21st, and 28th each month. The *WJG* Editorial Board consists of 1362 experts in gastroenterology and hepatology from 67 countries.

The primary task of *WJG* is to rapidly publish high-quality original articles, reviews, and commentaries in the fields of gastroenterology, hepatology, gastrointestinal endoscopy, gastrointestinal surgery, hepatobiliary surgery, gastrointestinal oncology, gastrointestinal radiation oncology, gastrointestinal imaging, gastrointestinal interventional therapy, gastrointestinal infectious diseases, gastrointestinal pharmacology, gastrointestinal pathophysiology, gastrointestinal pathology, evidence-based medicine in gastroenterology, pancreatology, gastrointestinal laboratory medicine, gastrointestinal molecular biology, gastrointestinal immunology, gastrointestinal microbiology, gastrointestinal genetics, gastrointestinal translational medicine, gastrointestinal diagnostics, and gastrointestinal therapeutics. *WJG* is dedicated to become an influential and prestigious journal in gastroenterology and hepatology, to promote the development of above disciplines, and to improve the diagnostic and therapeutic skill and expertise of clinicians.

INDEXING/ABSTRACTING *World Journal of Gastroenterology* is now indexed in Current Contents®/Clinical Medicine, Science Citation Index Expanded (also known as SciSearch®), Journal Citation Reports®, Index Medicus, MEDLINE, PubMed, PubMed Central, Digital Object Identifier, and Directory of Open Access Journals. ISI, Journal Citation Reports®, Gastroenterology and Hepatology, 2013 Impact Factor: 2.433 (36/74); Total Cites: 20957 (6/74); Current Articles: 1205 (1/74); and Eigenfactor® Score: 0.05116 (6/74).

FLYLEAF I-IX Editorial Board

EDITORS FOR THIS ISSUE Responsible Assistant Editor: *Xiang Li* Responsible Science Editor: *Yuan Qi*
 Responsible Electronic Editor: *Shuai Ma* Proofing Editorial Office Director: *Xiu-Xia Song*
 Proofing Editor-in-Chief: *Lian-Sheng Ma*

NAME OF JOURNAL
World Journal of Gastroenterology

ISSN
 ISSN 1007-9327 (print)
 ISSN 2219-2840 (online)

LAUNCH DATE
 October 1, 1995

FREQUENCY
 Weekly

EDITORS-IN-CHIEF
Damian Garcia-Olmo, MD, PhD, Doctor, Professor, Surgeon, Department of Surgery, Universidad Autonoma de Madrid; Department of General Surgery, Fundacion Jimenez Diaz University Hospital, Madrid 28040, Spain

Salah A Naser, PhD, Professor, Burnett School of Biomedical Sciences, College of Medicine, University of Central Florida, Orlando, FL 32816, United States

Stephen C Strom, PhD, Professor, Department of Laboratory Medicine, Division of Pathology, Karolinska Institutet, Stockholm 141-86, Sweden

Andrzej S Tarnawski, MD, PhD, DSc (Med), Professor of Medicine, Chief Gastroenterology, VA Long Beach Health Care System, University of California, Irvine, CA, 5901 E. Seventh Str., Long Beach, CA 90822, United States

EDITORIAL OFFICE
 Jin-Lei Wang, Director
 Xiu-Xia Song, Vice Director
World Journal of Gastroenterology
 Room 903, Building D, Ocean International Center, No. 62 Dongsihuan Zhonglu, Chaoyang District, Beijing 100025, China
 Telephone: +86-10-59080039
 Fax: +86-10-85381893
 E-mail: editorialoffice@wjgnet.com
 Help Desk: <http://www.wjgnet.com/esps/helpdesk.aspx>
<http://www.wjgnet.com>

PUBLISHER
 Baishideng Publishing Group Inc
 8226 Regency Drive,
 Pleasanton, CA 94588, USA
 Telephone: +1-925-223-8242
 Fax: +1-925-223-8243
 E-mail: bpgoffice@wjgnet.com
 Help Desk: <http://www.wjgnet.com/esps/helpdesk.aspx>

<http://www.wjgnet.com>

PUBLICATION DATE
 December 14, 2014

COPYRIGHT
 © 2014 Baishideng Publishing Group Inc. Articles published by this Open-Access journal are distributed under the terms of the Creative Commons Attribution Non-commercial License, which permits use, distribution, and reproduction in any medium, provided the original work is properly cited, the use is non commercial and is otherwise in compliance with the license.

SPECIAL STATEMENT
 All articles published in journals owned by the Baishideng Publishing Group (BPG) represent the views and opinions of their authors, and not the views, opinions or policies of the BPG, except where otherwise explicitly indicated.

INSTRUCTIONS TO AUTHORS
 Full instructions are available online at http://www.wjgnet.com/1007-9327/g_info_20100315215714.htm

ONLINE SUBMISSION
<http://www.wjgnet.com/esps/>

T₃-induced liver AMP-activated protein kinase signaling: Redox dependency and upregulation of downstream targets

Luis A Videla, Virginia Fernández, Pamela Cornejo, Romina Vargas, Paula Morales, Juan Ceballo, Alvaro Fischer, Nicolás Escudero, Oscar Escobar

Luis A Videla, Virginia Fernández, Pamela Cornejo, Romina Vargas, Paula Morales, Juan Ceballo, Alvaro Fischer, Nicolás Escudero, Oscar Escobar, Molecular and Clinical Pharmacology Program, Institute of Biomedical Sciences, Faculty of Medicine, University of Chile, Independencia 1027, Santiago, Chile
Pamela Cornejo, School of Medical Technology, Faculty of Medicine, Diego Portales University, Ejército 141, Santiago, Chile
Author contributions: Videla LA designed the research and wrote the article with the input of Fernández V, Cornejo P and Vargas R; Biochemical and molecular analyses were performed by Vargas R, Morales P, Ceballo J, Fischer A, Escudero N and Escobar O; all authors have approved the final manuscript and declare that there is no conflict of interest that could be perceived as prejudicing the impartiality of the research reported.

Supported by National Commission for Scientific and Technological Research Grant No. 1120034

Correspondence to: Luis A Videla, Professor, Molecular and Clinical Pharmacology Program, Institute of Biomedical Sciences, Faculty of Medicine, University of Chile, Independencia Avenue 1027, Chile. lvidela@med.uchile.cl

Telephone: +56-2-29786256 Fax: +56-2-27372783

Received: April 22, 2014 Revised: June 6, 2014

Accepted: July 29, 2014

Published online: December 14, 2014

Abstract

AIM: To investigate the redox dependency and promotion of downstream targets in thyroid hormone (T₃)-induced AMP-activated protein kinase (AMPK) signaling as cellular energy sensor to limit metabolic stresses in the liver.

METHODS: Fed male Sprague-Dawley rats were given a single ip dose of 0.1 mg T₃/kg or T₃ vehicle (NaOH 0.1 N; controls) and studied at 8 or 24 h after treatment. Separate groups of animals received 500 mg N-acetylcysteine (NAC)/kg or saline ip 30 min prior T₃. Measurements included plasma and liver 8-isoprostane and serum β -hydroxybutyrate levels (ELISA), hepatic

levels of mRNAs (qPCR), proteins (Western blot), and phosphorylated AMPK (ELISA).

RESULTS: T₃ upregulates AMPK signaling, including the upstream kinases Ca²⁺-calmodulin-dependent protein kinase kinase- β and transforming growth factor- β -activated kinase-1, with T₃-induced reactive oxygen species having a causal role due to its suppression by pretreatment with the antioxidant NAC. Accordingly, AMPK targets acetyl-CoA carboxylase and cyclic AMP response element binding protein are phosphorylated, with the concomitant carnitine palmitoyltransferase-1 α (CPT-1 α) activation and higher expression of peroxisome proliferator-activated receptor- γ co-activator-1 α and that of the fatty acid oxidation (FAO)-related enzymes CPT-1 α , acyl-CoA oxidase 1, and acyl-CoA thioesterase 2. Under these conditions, T₃ induced a significant increase in the serum levels of β -hydroxybutyrate, a surrogate marker for hepatic FAO.

CONCLUSION: T₃ administration activates liver AMPK signaling in a redox-dependent manner, leading to FAO enhancement as evidenced by the consequent ketogenic response, which may constitute a key molecular mechanism regulating energy dynamics to support T₃ preconditioning against ischemia-reperfusion injury.

© 2014 Baishideng Publishing Group Inc. All rights reserved.

Key words: Liver; Thyroid hormone; N-acetylcysteine; AMP-activated protein kinase; Fatty acid oxidation

Core tip: This work investigated the redox dependency and promotion of downstream targets in thyroid hormone (T₃)-induced AMP-activated protein kinase (AMPK) signaling. T₃ upregulates AMPK with T₃-induced reactive oxygen species having a causal role due to its suppression by pretreatment with the antioxidant NAC. Accordingly, AMPK targets acetyl-CoA carboxylase and cyclic AMP response element binding protein

are phosphorylated, with the concomitant carnitine palmitoyltransferase-1 α activation and higher expression of peroxisome proliferator-activated receptor- γ co-activator-1 α and that of the fatty acid oxidation (FAO)-related enzymes. This lead to enhancement in the serum levels of β -hydroxybutyrate, a surrogate marker for hepatic FAO, which represent a key molecular mechanism regulating energy dynamics to limit metabolic stresses.

Videla LA, Fernández V, Cornejo P, Vargas R, Morales P, Ceballos J, Fischer A, Escudero N, Escobar O. T₃-induced liver AMP-activated protein kinase signaling: Redox dependency and up-regulation of downstream targets. *World J Gastroenterol* 2014; 20(46): 17416-17425 Available from: URL: <http://www.wjgnet.com/1007-9327/full/v20/i46/17416.htm> DOI: <http://dx.doi.org/10.3748/wjg.v20.i46.17416>

INTRODUCTION

Genomic^[1] and nongenomic^[2] mechanisms underlying thyroid hormone action are responsible for cellular responses such as O₂ consumption of most tissues and the metabolic rate of individuals. The liver, a target organ for L-3,3,5-triiodothyronine (T₃) calorogenesis, exhibits a concomitant enhancement in reactive oxygen species (ROS) production, which is due to acceleration of mitochondrial respiration and activation of other ROS-generating systems^[3]. Under these conditions, activation of redox-sensitive transcription factors nuclear factor- κ B, activating protein-1, signal transducer and activator of transcription-3, and nuclear factor (erythroid-derived 2)-like 2 is achieved, with promotion of cell proliferation and the expression of cytoprotective proteins including antioxidant, anti-apoptotic, and acute-phase proteins, phase-II detoxification enzymes, and phase-III transporters^[3,4]. Thus, *in vivo* T₃ administration re-establishes redox homeostasis, promotes cell survival, and protects the liver against ischemia-reperfusion injury (IRI), which constitute the basis for T₃ liver preconditioning^[5,6] and an important issue in post-stress recovery and repair^[7].

Organ preconditioning (PC) refers to the development of an increased tolerance to noxious stimuli such IRI due to previous maneuvers triggering beneficial molecular and functional changes. In the liver, numerous experimental PC and post-conditioning strategies have been proposed, however, difficulties with gene therapy and pharmacological maneuvers have hindered their transfer to clinical practice, whereas those based on surgical approaches are limited or controversial^[8]. In this respect, the T₃ PC strategy has potential clinical application, considering that T₃ is a widely employed and well-tolerated therapeutic agent whose side effects are readily controlled, and that its mechanisms of PC action are beginning to be understood^[3,5,6]. Among these, AMP-activated protein kinase (AMPK) may constitute the metabolic basis of T₃ liver PC, as effective PC involves high ATP demands to

power the expression of numerous protective proteins, oxidized biomolecules repair (phospholipids, DNA) or resynthesis (proteins), and hepatocyte and Kupffer-cell proliferation, in addition to energy requirements needed for normal hepatic metabolic, secretory, and excretory functions^[9-11]. AMPK is considered a key energy sensor able to limit anabolic pathways, to reduce ATP consumption, and to facilitate catabolic pathways, to increase ATP production^[9]. In the present study, we show that T₃ administration to rats significantly enhances liver (1) AMPK signaling in a redox-sensitive manner; (2) the phosphorylation of downstream AMPK targets; and (3) the expression of components associated with fatty acid (FA) oxidation (FAO), leading to a ketogenic response.

MATERIALS AND METHODS

Animal treatments

Male Sprague Dawley rats (Animal facility of the Institute of Biomedical Sciences, Faculty of Medicine, University of Chile) weighing 180-200 g were housed on a 12-hour light/dark cycle and were provided with rat chow and water *ad libitum*. Animals received a single intraperitoneal (*ip*), dose of 0.1 mg T₃/kg body weight or equivalent volumes of hormone vehicle (0.1 mol/L NaOH, controls) at time zero and studies were done after 24 h of treatment. Studies with N-acetylcysteine (NAC) were carried out in the above described groups receiving either 0.5 g/kg or saline (controls) *ip*, 0.5 h before T₃ administration, and studies were performed at 8 or 24 h after treatment in four experimental groups, namely, (1) controls; (2) T₃; (3) NAC; and (4) NAC + T₃. T₃-induced calorogenesis was assessed by the rectal temperature of the animals by means of a thermocouple (Cole-Palmer Instrument Co., Chicago, IL). Blood samples to measure 8-isoprostanes in plasma and β -hydroxybutyrate in serum were obtained by cardiac puncture in rats anesthetized (1 mL/kg) with zolazepam chlorhydrate (25 mg/mL) and tiletamine chlodrihydrate (25 mg/mL) *ip* (Zoletil 50; Virbac S/A, Carros, France), and liver samples were taken, frozen in liquid nitrogen, and kept at -80 °C for measurements of mRNA and protein expression. All experiments and animal procedures were performed in accordance with the Guide for the Care and Use of Laboratory Animals (National Academy of Sciences, NIH Publication 6-23, revised 1985) and were approved by the Bioethics Committee for Research in Animals, Faculty of Medicine, University of Chile (Protocol CBA 0381 FMUCH).

8-isoprostanes and β -hydroxybutyrate levels

Liver and plasma 8-isoprostane levels were measured in samples frozen in liquid nitrogen and kept at -80 °C, using a commercial kit (ELISA; Cayman Chemical Co., Ann Arbor, MI, United States) according to the manufacturer's instructions at 405-420 nm. Results were calculated from a standard curve and expressed as ng/g of liver or pg/mL of plasma, respectively. Serum β -hydroxybutyrate levels were assayed in samples frozen in liquid nitrogen and

Table 1 Primers for SYBR green based qRT-PCR assays

mRNA	Forward primer	Reverse primer
Rat ACC α	GAC GTT CGC CAT AAC CAA GT	CTG CAG GTT CTC AAT GCA AA
Rat ACC β	CCT GTA GAT GCC AGT CAG CA	AGT TCT GGG GAG GAA CAG GT
Rat ACOT2	TCA GGA TGA CCA CAACTG GA	ATG TTA GAC CCC ACC AGG AG
Rat ACOX1	CTG ATG AAA TAC GCC CAG GT	GGT CCC ATA CGT CAG CTT GT
Rat AMPK	TTT GCC TAG AAT CCC CAC AG	TAA GGA GCC CAG AAA ACA GC
Rat β -actin	AGC CAT GTA CGT AGC CAT CC	CTC TCA GCT GTG GTG GTG AA
Rat CaMKK β	GGA TTG TGG TGC CTG AAA TC	AGG CTG GGA ATG TGT TTG AC
Rat CPT-1 α	CAG CTC GCA CAT TAC AAG GA	TGC ACA AAG TTG CAG GAC TC
Rat CREB	TCA GCC GGG TAC TAC CAT TC	CCT CTC TCT TTC GTG CTG CT
Rat PGC-1 α	TCC ACA GAT TCA AGC CAG TG	TGA CCG AAG TGC TTG TTC AG
Rat RPS23	GTA GGG GTT GAA GCC AAA CA	CAC CTT AAA GCG GAC TCC AG
Rat TAK1	AAC AAG TCC CTG CCA CAA AC	CAT CCT CTT GCC CTC AGA AG

Sequences are listed in the 5' \rightarrow 3' direction. ACC α (β): Acetyl-CoA carboxylase α and β ; ACOT2: Acyl-CoA thioesterase; ACOX1: acyl-CoA oxidase 1; AMPK: AMP-activated protein kinase; CaMKK β : Ca²⁺-Calmodulin-dependent protein kinase β ; CPT-1 α : Carnitine palmitoyltransferase-1 α ; CREB: cAMP-response element-binding protein; PGC-1 α : Peroxisome proliferator-activated receptor- γ coactivator-1 α ; RPS23: Ribosomal protein S23; TAK1: Transforming growth factor- β -activated kinase-1.

kept at -80 °C, using a commercial kit (ELISA; BioVision Incorporated, CA, United States) according to the manufacturer's instructions at 450 nm. Results were calculated from a standard curve and expressed in μ mol/L units.

RNA isolation and cDNA synthesis

Total RNA was isolated using RNeasy[®] Lipid Tissue Mini Kit (QUIAGEN Sciences, Maryland, United States) according to the manufacturer's instructions. cDNA was synthesized using ThermoScript[™] RT-PCR System (Life Technologies Corporation, Carlsbad, California, United States) according to the manufacturer's instructions.

Real-time quantitative PCR for AMPK, CaMKK β , TAK1, ACC- α (β), CREB, PGC-1 α , CPT-1 α , ACOX1, and ACOT2

Real-time quantitative PCR was carried out in a Stratagene Mx3005P (Agilent Technologies, California, United States) using Brilliant II SYBR Green QPCR Master Mix (Agilent Technologies, California, United States) following the manufacturer's protocols. Gene specific primer sequences used are shown in Table 1. Primers were optimized to yield 95%-100% reaction efficiency with PCR products run on agarose gel to verify the correct amplification length. Melt curve analyses verified the formation of a single desired PCR product in each PCR reaction. The expression levels of each sample were normalized against RPS23 and β -actin (internal controls). The relative expression levels were calculated using the comparative C_T method ($\Delta\Delta$ C_T) and values were normalized to RPS23 level or β -actin level as internal control genes.

Western Blot Analysis for CaMKK β , TAK1 and pTAK1, ACC and pACC, CREB and pCREB, CPT-1 α , ACOX1, and ACOT2

Liver samples (100-500 mg) frozen in liquid nitrogen were homogenized and suspended in 1.5 mL of a buffer solution (pH 7.9), containing 10 mmol/L Hepes, 1 mmol/L EDTA, 0.6% NP-40, 150 mmol/L NaCl, 0.5

mmol/L PMSF, protease inhibitors (1 μ g/mL aprotinin, 1 μ g/mL leupeptin) and fosfatase inhibitor (1 mmol/L orthovanadate) followed by centrifugation (3000 *g* for 5 min). Cytosolic soluble protein fractions (70 μ g) were separated on 12% polyacrylamide gels using sodium dodecyl sulfate polyacrylamide gel electrophoresis (SDS-PAGE)^[12] and transferred to nitrocellulose membranes^[13], which were blocked for 1 h at room temperature with Tris buffer saline (TBS) containing 5% bovine serum albumin. The blots were washed with TBS containing 0.5% Tween 20 and hybridized with rabbit polyclonal primary antibodies for CaMKK β , TAK1, pTAK1, pACC, and CPT-1 α (1:1000; Abcam, Cambridge, MA, United States), PGC-1 α , ACC, α -tubulin, and lamin A/C (1:1000; Cell Signalling Technology, Inc, MA, United States), pCREB and CREB (1:1000; EMD Millipore Corporation, Billerica, MA, United States); acyl-coenzyme A thioesterase 2 (ACOT2) and acyl-coenzyme A oxidase 1 (ACOX1) (1:1000, Santa Cruz Biotechnology, Inc, Santa Cruz, CA, United States). In all determinations, rabbit monoclonal antibody for anti- α -tubulin was used as internal control and anti-lamin A/C was employed as control for purity. After extensive washing, the antigen-antibody complexes were detected using horseradish peroxidase goat anti-rabbit IgG or goat anti-mouse IgG and SuperSignal West Pico Chemiluminescence kit detection system (Pierce, Rockford, IL, United States). Bands were quantified by densitometry using Gel Documentation System Biosens SC-750 (Shanghai Bio-Tech Co., Ltd., China). Results are expressed as relative units (individual protein/ α -tubulin), with further normalization by the average values obtained in the control groups.

AMPK α [pT172] ELISA kit

AMPK α [pT172] concentration was determined by AMPK α [pT172] ELISA kit (Invitrogen Corporation, CA, United States) according to the manufacturer's instructions and read the plate at a wavelength at 450 nm. Results were calculated from a standard curve.

Statistical analysis

Data showing Gaussian distribution according to the Kolmogorov-Smirnov test are expressed as means \pm SEM for the number of separate experiments indicated. As required, one-way ANOVA analysis of variance and the Newman-Keuls test or the Student's *t*-test for unpaired data assessed the statistical significance ($P < 0.05$) of differences between mean values. To analyze the association between different variables, the Pearson correlation coefficient was used. All statistical analyses were computed employing GraphPad Prism™ version 2.0 (GraphPad Software, Inc., San Diego, CA, United States).

RESULTS

Liver AMPK upregulation by T₃ administration is redox-sensitive

The administration of a single dose of T₃ to fed rats elicited a calorogenic response, with (1) increases in the rectal temperature of the animals (8 h after treatment, controls, 36.5 ± 0.04 ($n = 4$) °C; T₃-treated rats, 38.0 ± 0.2 ($n = 5$); $P < 0.05$; 24 h after treatment, controls, 36.3 ± 0.06 ($n = 13$); T₃-treated rats, 37.7 ± 0.17 ($n = 13$); $P < 0.05$); and (2) the associated development of liver oxidative stress as evidenced by increases in O₂ consumption in the time range of 2–24 h^[14], with enhanced protein carbonylation at 12 h and glutathione depletion at 24 h after T₃^[5], and higher levels of 8-isoprostanes in plasma (112% higher) and liver (41% higher) over control values at 24 h (Figure 1A). The enhancement in 8-isoprostane levels as index related of oxidative stress was suppressed by 0.5 g of NAC/kg given 0.5 h before T₃ (Figure 1A). Under these conditions, NAC treatment did not modify the mRNA expression of AMPK (Figure 1B) or that of the upstream kinases Ca²⁺-calmodulin-dependent protein kinase kinase- β (CaMKK β) (Figure 1C) and transforming growth factor- β -activated kinase-1 (TAK1) (Figure 1D), or the protein levels of CaMKK β (Figure 1E). TAK1 activation by phosphorylation was significantly increased by NAC over controls (Figure 1F). Consistent with a previous report showing liver T₃-induced AMPK upregulation in the period of 8–36 h after treatment^[15], the enhancement in AMPK activation observed at 24 h was abolished by NAC (Figure 1B). Furthermore, early (8 h) CaMKK β upregulation (Figure 1C and E) and late (24 h) enhancement in TAK1 mRNA expression and phosphorylation (Figure 1D and F) induced by T₃ were either suppressed or significantly diminished by NAC pretreatment.

Liver AMPK phosphorylation targets are enhanced by T₃ administration

T₃-induced liver AMPK upregulation (Figure 1B and 2A) was found to trigger two major downstream signaling pathways, namely, acetyl-CoA carboxylase α and β (ACC α and ACC β) and cyclic AMP response element binding protein (CREB), either through mRNA expression or protein phosphorylation (Figure 2C and D), parameters that were significantly correlated (Figure 2E). These

changes occurred with the concomitant increase in the mRNA expression of hepatic peroxisome proliferator-activated receptor (PPAR)- γ co-activator-1 α (PGC-1 α) (Figure 2B).

Liver AMPK-dependent metabolically operative targets are increased by T₃ administration

T₃ administration enhanced hepatic mRNA expression of PGC-1 α over control values by 2.15-fold, which correlated with the 37% increase in CPT-1 α protein content (Figure 3A) ($r = 0.86$; $P < 0.02$). Under these conditions, PGC-1 α upregulation by T₃ was associated with increased expression of the FAO-related enzymes ACOX1 (Figure 3B and ACOT2 (Figure 3C), both at transcriptional and translational levels, with 72% enhancement in serum β -hydroxybutyrate levels over control values (Figure 3D).

DISCUSSION

Data presented indicate that T₃-induced liver AMPK upregulation is accomplished through enhancement in AMPK transcription and AMPK phosphorylation associated with early CaMKK β and late TAK1 activation, as upstream AMPK kinases^[9], mechanisms subjected to redox signaling due to their abrogation by the ROS suppressive action of NAC. The NAC protocol used results in significant circulating levels of the antioxidant^[16], which decline within 24 h due to the elimination half-life of 1–4.3 h^[17], an agent having a potent antioxidant activity due to its direct ROS scavenging action and the stimulation of hepatocellular glutathione synthesis^[18]. Although NAC did not alter the mRNA expression of CaMKK β , TAK1, and AMPK, TAK1 phosphorylation was significantly increased, an effect that could be ascribed to the maintenance of relevant sulfhydryl groups in proteins in the reduced state^[19], which may lead to modifications of signal transduction pathways by favoring the phosphorylation process. In agreement with the causal role of ROS in AMPK upregulation induced by T₃, ROS trigger cellular AMPK activation under different conditions including (1) *in vitro* hydrogen peroxide (H₂O₂) addition to cell cultures^[20–23]; (2) *in vitro* and *in vivo* conditions underlying ROS production in hepatocytes, heart, or skeletal muscle^[24–26]; and (3) ROS generation associated with chain reactions induced by polyphenols^[27]. In this respect, H₂O₂ is considered as a major ROS able to achieve redox signaling that can be achieved by reversible oxidation of cysteine residues in signaling proteins into cysteine-sulfenate derivatives, glutathionylation, or intramolecular disulfide formation^[28], H₂O₂ being significantly enhanced in hyperthyroid state^[3].

Upregulation of liver AMPK by T₃, as evidenced by the increase in hepatic AMPK mRNA levels, is in agreement with the observed higher Thr172-phosphorylated AMPK levels, which in turn correlate with the activation of CaMKK β and TAK1 as upstream kinases. These data suggest that T₃ substantially enhances the phosphorylating potential of hepatic AMPK, considering the higher

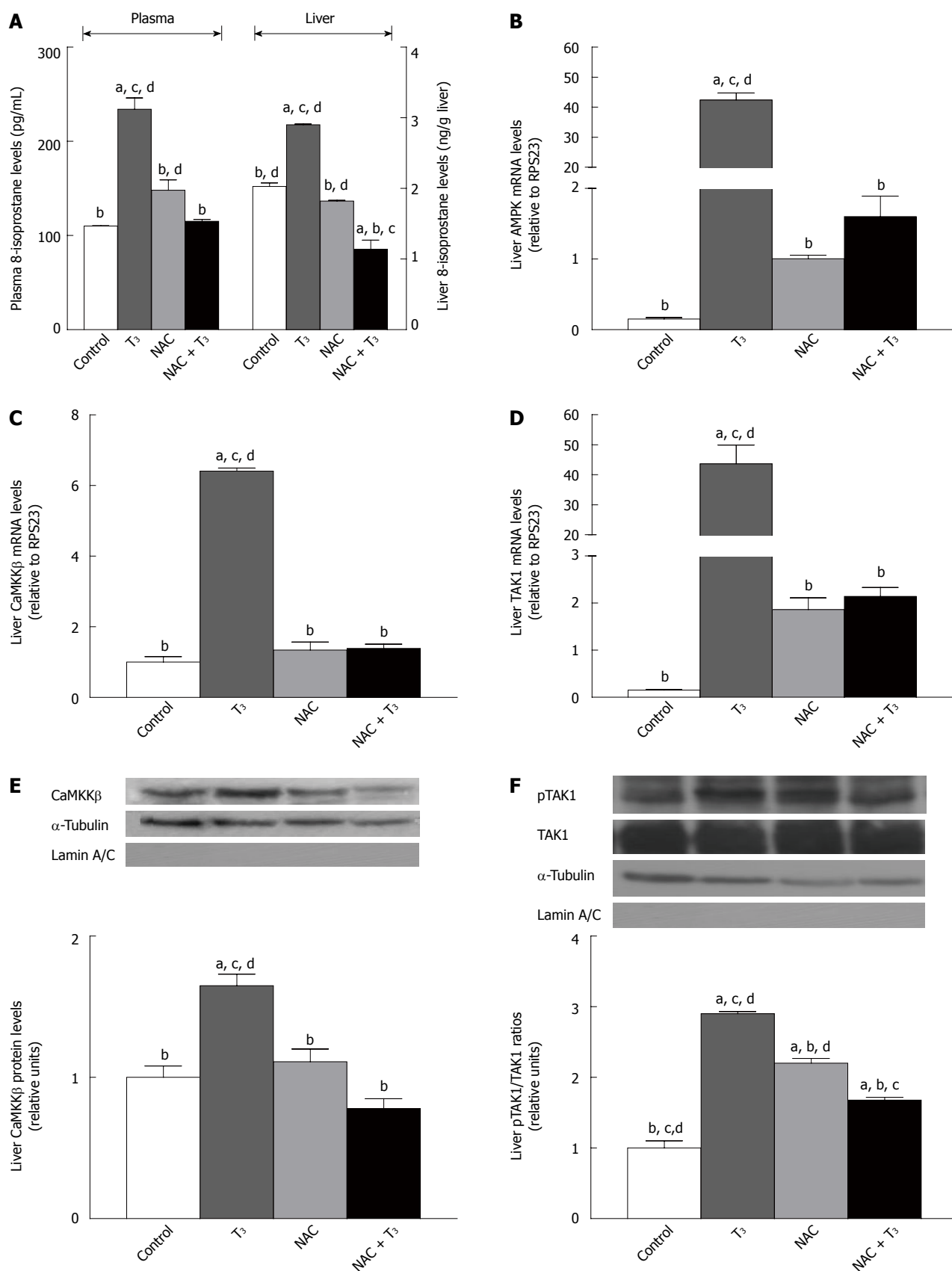

Figure 1 Effect of N-acetylcysteine on T₃-induced liver CaMKKβ/TAK1-AMPK cascade. (A) Rat plasma and liver 8-isoprostane levels, liver mRNA levels of AMPK (B) and CaMKKβ (C, E) hepatic CaMKKβ protein content, and liver expression of TAK1 mRNA (D) and pTAK1/TAK1 ratios (F). Values shown are means ± SEM (*n* = 3-4). Statistical significance (one-way ANOVA and the Newman-Keuls' test; *P* < 0.05) is indicated by the letters identifying each experimental group. AMPK: AMP-activated protein kinase; CaMKKβ: Ca²⁺-calmodulin-dependent protein kinase kinase-β; NAC: N-acetylcysteine; (p)TAK1, (phosphorylated) transforming growth factor-β-activated kinase-1.

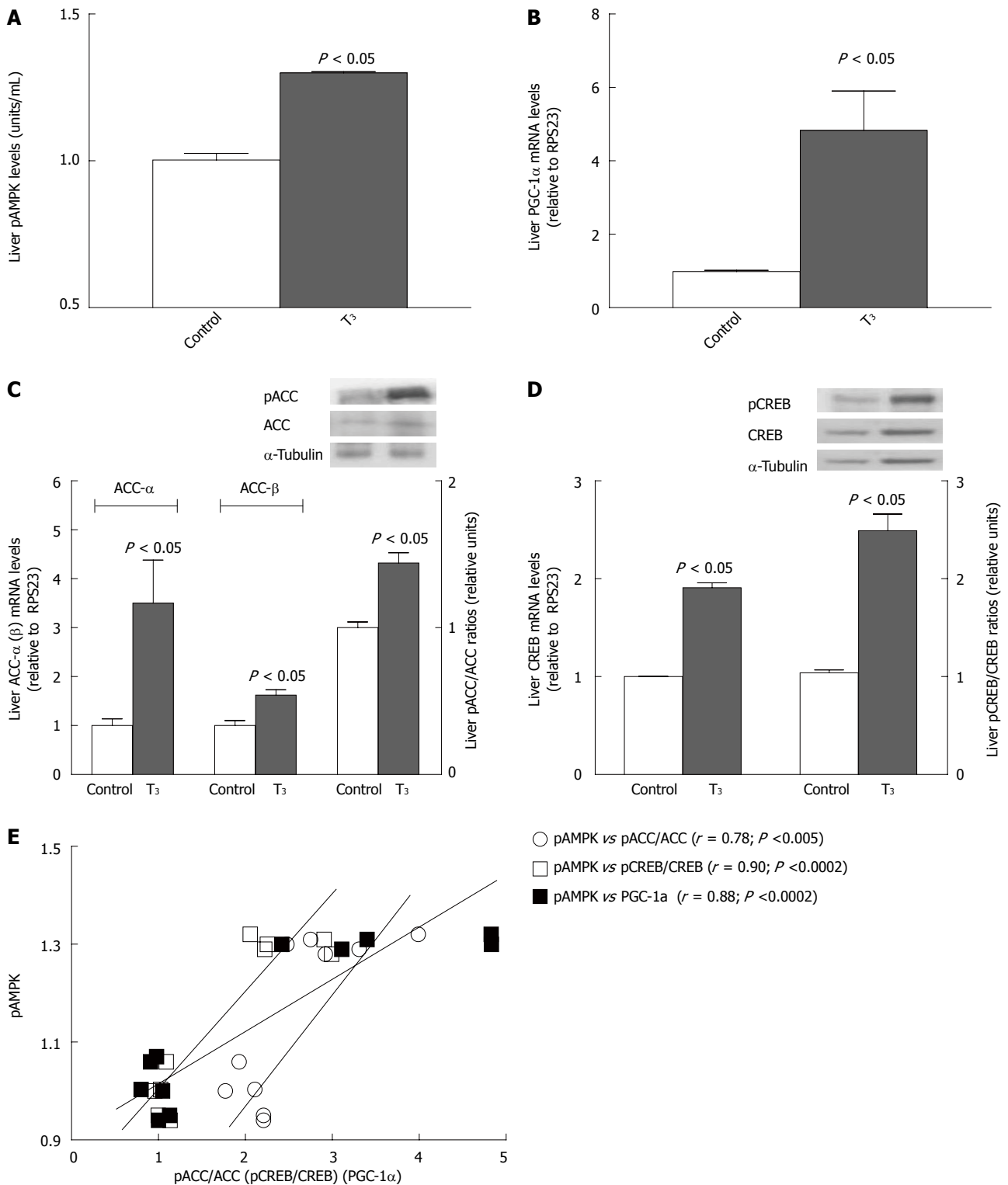

Figure 2 T₃-induced changes in liver direct AMP-activated protein kinase targets. A: pAMPK levels; B: PGC-1 α mRNA content; C: Contents of ACC- α mRNA and pACC- α ; D: Levels of CREB mRNA and pCREB/CREB ratios; E: Correlations between pAMPK and pACC- α , pCREB/CREB ratios, and PGC-1 α . Values shown are means \pm SEM ($n = 3-6$). Statistical significance was performed by one-way ANOVA and the Newman-Keuls' test (C, D) or Student's *t*-test for unpaired data (A, B) ($P < 0.05$). Associations between variables were analyzed by the Pearson correlation coefficient. pAMPK: Phosphorylated AMP-activated protein kinase; (p) ACC- α : (Phosphorylated) acetyl-CoA carboxylase- α ; (p)CREB: (phosphorylated) cAMP-response element-binding protein; PGC-1 α : Peroxisome proliferator-activated receptor- γ coactivator-1 α .

transcriptional activity of the *AMPK* gene and the activation of the enzyme by both phosphorylation (Figure 2A) and by the concomitant increase in the hepatocellular AMP/ATP ratio previously observed^[15]. Phosphoryla-

tion of hepatic ACC by activated AMPK is known to result in ACC inhibition, with a substantial diminution in the levels of malonyl-CoA, the potent allosteric inhibitor of CPT-1 α that favors the entry of acyl-CoAs into

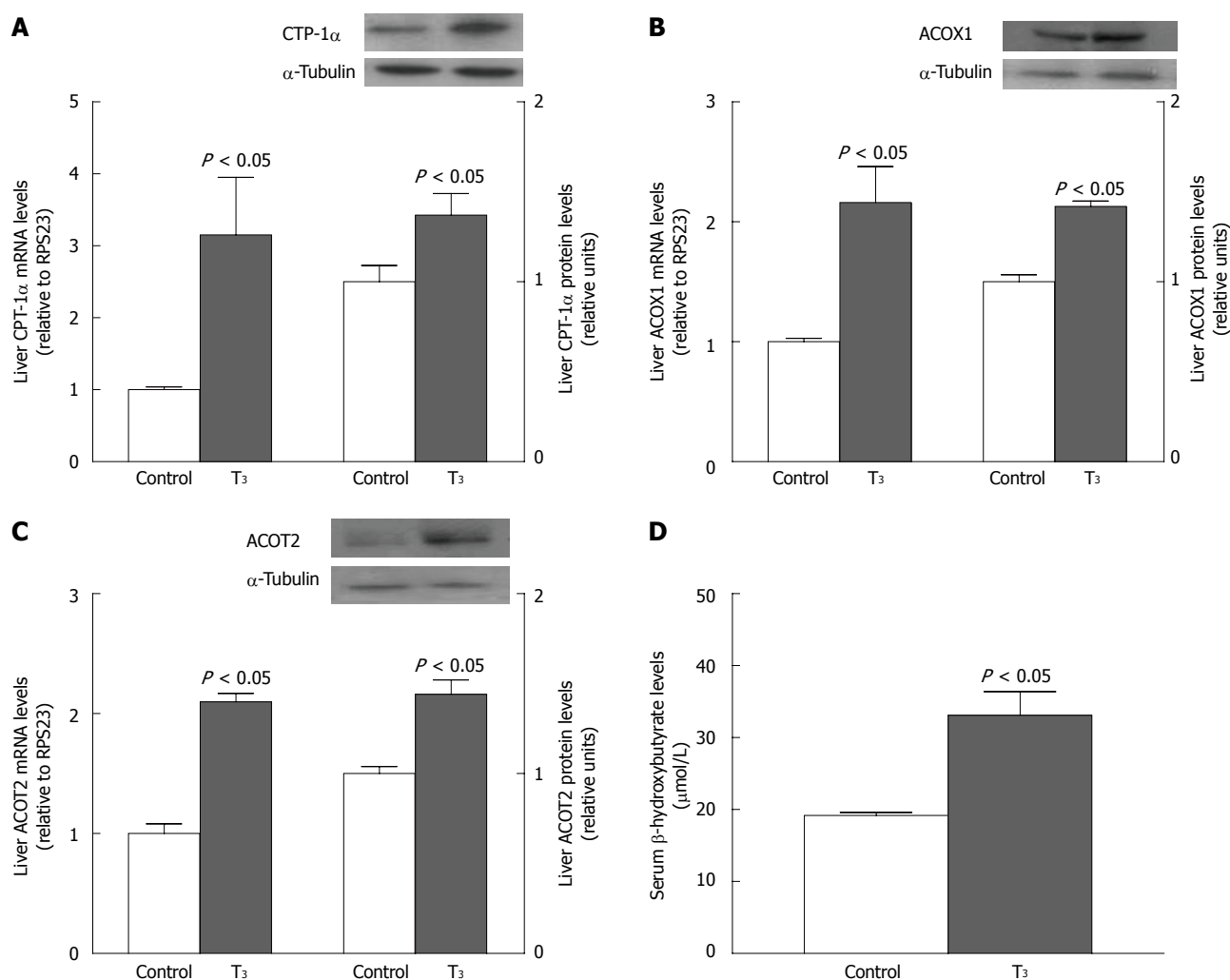

Figure 3 T₃-induced changes in liver AMPK-dependent targets related to fatty acid oxidation. mRNA and protein levels of CPT-1 α (A), ACOX1 (B), and ACOT2 (C), and circulating levels of β -hydroxybutyrate (D). Values shown are means \pm SEM ($n = 3-5$). Statistical significance was performed by Student's t-test for unpaired data ($P < 0.05$). AMPK: AMP-activated protein kinase; ACOT2: Acyl-CoA thioesterase 2; ACOX1: Acyl-CoA oxidase 1; CPT-1 α : Carnitine palmitoyltransferase-1 α .

mitochondria thus enhancing the FAO potential of the liver^[9,29]. In addition to ACC, T₃-induced AMPK activation is associated with increased CREB mRNA expression and CREB phosphorylation, a transcription factor that is central to diverse cellular responses including those related to T₃ signaling. In fact, after inducing the dissociation of the repression complex, T₃ stimulates the recruitment of several nuclear co-activators including CREB-binding protein (CBP/p300), which facilitates T₃/thyroid hormone receptor-dependent transcription activation^[30]. This is accomplished by AMPK-dependent CREB phosphorylation at Ser133^[31], which is known to increase its association with co-activator CBP/p300^[32]. Interestingly, T₃ administration significantly increased the mRNA expression of hepatic PGC-1 α , which co-activates several transcription factors associated with mitochondrial biogenesis that may also enhance the capacity of the cell for FAO^[29]. Furthermore, activated AMPK is able to elicit PGC-1 α activation by direct phosphorylation^[33], whereas control of PGC-1 α transcription is partially mediated by CREB^[29]. Taken as a whole, these data suggest that T₃ triggers liver AMPK upregulation confronting FAO,

which appears to be associated with (1) phosphorylation of its target enzyme ACC; and (2) phosphorylation and transcriptional regulation of CREB and PGC-1 α , signaling components that may undergo reinforcing mechanisms.

Transcriptional activation of nuclear receptor target genes is known to be triggered by co-activator molecules. These include PGC-1 α that upon activation coordinates induction of hepatic FA oxidation *via* co-activation of transcription factors PPAR- α , nuclear respiratory factors 1 and 2, and estrogen receptor-related- α ^[34]. Accordingly, PGC-1 α plays a role in the transduction of the T₃ stimulus to the transcriptional regulation of genes involved in liver energy metabolism, as proposed for cold exposure or fasting^[35]. Thus, T₃-induced liver AMPK signaling may involve CREB-CBP/p300 interaction with PGC-1 α upregulation leading to the PPAR- α -dependent expression of FAO-related enzymes (Figure 4). These include (1) CPT-1 α facilitating the entry of FAs into mitochondria for FAO; (2) ACOX1, a peroxisomal enzyme catalyzing the FAD-dependent desaturation of long-chain acyl-coenzyme A derivatives; and (3) ACOT2, a mitochondrial

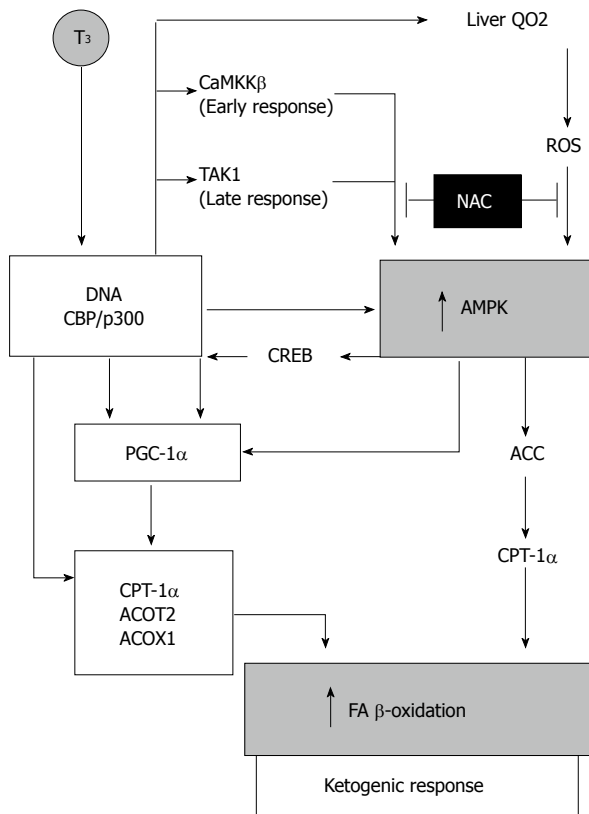

Figure 4 Schematic representation of T₃ signaling related to AMPK up-regulation and consequent fatty acid oxidation enhancement. ACC: Acetyl-CoA carboxylase; ACOT2: acyl-CoA thioesterase 2; ACOX1: acyl-CoA oxidase 1; AMPK: AMP-activated protein kinase; CaMKKβ: Ca²⁺-calmodulin-dependent protein kinase kinase-β; CBP/p300: CREB-binding protein; CPT-1α: Carnitine palmitoyltransferase-1α; CREB: cAMP-response element-binding protein; FA: Fatty acid; PGT-1α: Peroxisome proliferator-activated receptor-γ coactivator-1α; QO₂: Rate of oxygen consumption; ROS: Reactive oxygen species; TAK1: Transforming growth factor-β-activated kinase-1.

enzyme hydrolyzing acyl-coenzyme A thioesters to release free coenzyme A for FAO^[9,36,37] (Figure 4). In agreement with this proposal, T₃ administration resulted in a significant 72% enhancement in serum β-hydroxybutyrate levels over control values, a liver-derived ketone body that is considered a surrogate marker for hepatic FAO^[9].

In conclusion, data presented indicate that T₃-induced ROS production, revealed by higher 8-isoprostane levels in liver and plasma, have a causal role in upregulating rat liver AMPK signaling, resulting in FAO enhancement to support energy-demanding processes such as T₃-PC or tissue repair^[5-7] (Figure 4). This is evidenced by suppression of T₃-induced hepatic AMPK mRNA levels and those of the upstream kinases CaMKKβ and TAK1, as well as their protein expression, by pretreatment with the antioxidant NAC previous to T₃, findings that agree with higher pAMPK levels observed over control values. In addition, the higher AMPK phosphorylation potential elicited by T₃ is associated with enhancement in hepatic pACC/ACC and pCREB/CREB ratios as direct targets of activated AMPK (Figure 4). The latter changes induced by T₃ trigger FAO as assessed by the consequent ketogenic response, which may involve both ACC phos-

phorylation, with CPT-1α activation, and CREB phosphorylation, with enhanced expression of co-activator PGC-1α and that of the FAO-related enzymes CPT-1α, ACOX1, and ACOT2 (Figure 4). Enhancement in FAO-related energy metabolism by T₃ is in accordance with the enhanced liver ATP turnover reported^[15,38], which may comply with high-energy requiring processes such as liver PC^[5,6]. In agreement with this contention, T₃ was recently shown to stimulate hepatic FAO coupled with the induction of autophagy, a stress-related process degrading cellular components to produce FAs to generate ATP or amino acids to synthesize proteins for cell survival^[39]. Thyroid hormone PC is not restricted to the liver, considering that protective effects against IRI are also observed in the heart^[40,41], kidney^[42,43], and brain^[44]. In addition to ischemia-reperfusion injury, thyroid hormones have a critical role in the repair in several tissues subjected to other types of injury, namely, mechanical injury, nerve transection, chemotherapy-induced toxicity, hyperoxia injury, serum starvation, or wound^[7].

COMMENTS

Background

Liver preconditioning (PC) increases the tolerance to noxious stimuli such as ischemia-reperfusion injury due to previous maneuvers triggering beneficial changes, as shown for thyroid hormone (T₃) administration.

Research frontiers

T₃ liver PC involves promotion of cell proliferation and the expression of cytoprotective proteins including antioxidant, anti-apoptotic, and acute-phase proteins, phase-II detoxification enzymes, and phase-III transporters. In this research article, the authors addressed the study of AMP-activated protein kinase (AMPK) signaling as the metabolic basis for T₃ liver PC providing energy to power cytoprotective mechanisms.

Innovations and breakthroughs

T₃ administration to rats upregulates liver AMPK in a redox-dependent manner, as evidenced by its abrogation by pretreatment with the antioxidant N-acetylcysteine prior to T₃. The resulting AMPK activation is associated with phosphorylation of downstream targets leading to fatty acid oxidation enhancement, as shown by the increased ketogenic response, representing a molecular mechanism regulating energy dynamics.

Applications

Numerous experimental liver PC strategies have not been transferred to clinical practice due to major drawbacks and conflicting results. In this context, T₃ liver PC has potential clinical application as it is a well-tolerated therapeutic agent whose side effects are readily controlled.

Terminology

AMPK is considered a key energy sensor able to limit anabolic pathways, to diminish ATP consumption, and to facilitate catabolic pathways, to increase ATP production, thus limiting metabolic stresses in the liver.

Peer review

This is a detailed report on the mechanisms of T₃ in mediating AMPK signaling. The authors covered a range of early and late kinases in detail and showed that T₃ mediates AMPK signaling in a redox dependent manner.

REFERENCES

- 1 **Harvey CB**, Williams GR. Mechanism of thyroid hormone action. *Thyroid* 2002; **12**: 441-446 [PMID: 12165104 DOI: 10.1089/105072502760143791]
- 2 **Arnold S**, Goglia F, Kadenbach B. 3,5-Diiodothyronine binds to subunit Va of cytochrome-c oxidase and abolishes the allosteric inhibition of respiration by ATP. *Eur J*

- Biochem* 1998; **252**: 325-330 [PMID: 9523704 DOI: 10.1046/j.1432-1327.1998.2520325.x]
- 3 **Videla LA.** Hormetic responses of thyroid hormone calorigenesis in the liver: Association with oxidative stress. *IUBMB Life* 2010; **62**: 460-466 [PMID: 20503439 DOI: 10.1002/iub.345]
 - 4 **Cornejo P, Vargas R, Videla LA.** Nrf2-regulated phase-II detoxification enzymes and phase-III transporters are induced by thyroid hormone in rat liver. *Biofactors* 2013; **39**: 514-521 [PMID: 23554160 DOI: 10.1002/biof.1094]
 - 5 **Fernández V, Castillo I, Tapia G, Romanque P, Uribe-Echevarría S, Uribe M, Cartier-Ugarte D, Santander G, Vial MT, Videla LA.** Thyroid hormone preconditioning: protection against ischemia-reperfusion liver injury in the rat. *Hepatology* 2007; **45**: 170-177 [PMID: 17187421 DOI: 10.1002/hep.21476]
 - 6 **Taki-Eldin A, Zhou L, Xie HY, Chen KJ, Yu D, He Y, Zheng SS.** Triiodothyronine attenuates hepatic ischemia/reperfusion injury in a partial hepatectomy model through inhibition of proinflammatory cytokines, transcription factors, and adhesion molecules. *J Surg Res* 2012; **178**: 646-656 [PMID: 22727940 DOI: 10.1016/j.jss.2012.05.069]
 - 7 **Mourouzis I, Politi E, Pantos C.** Thyroid hormone and tissue repair: new tricks for an old hormone? *J Thyroid Res* 2013; **2013**: 312104 [PMID: 23533950]
 - 8 **Bahde R, Spiegel HU.** Hepatic ischaemia-reperfusion injury from bench to bedside. *Br J Surg* 2010; **97**: 1461-1475 [PMID: 20645395 DOI: 10.1002/bjs.7176]
 - 9 **Viollet B, Guigas B, Leclerc J, Hébrard S, Lantier L, Mounier R, Andreelli F, Foretz M.** AMP-activated protein kinase in the regulation of hepatic energy metabolism: from physiology to therapeutic perspectives. *Acta Physiol (Oxf)* 2009; **196**: 81-98 [PMID: 19245656 DOI: 10.1111/j.1748-1716.2009.01970.x]
 - 10 **Fernández V, Tapia G, Videla LA.** Recent advances in liver preconditioning: Thyroid hormone, n-3 long-chain polyunsaturated fatty acids and iron. *World J Hepatol* 2012; **4**: 119-128 [PMID: 22567184 DOI: 10.4254/wjh.v4.i4.119]
 - 11 **Hasenour CM, Berglund ED, Wasserman DH.** Emerging role of AMP-activated protein kinase in endocrine control of metabolism in the liver. *Mol Cell Endocrinol* 2013; **366**: 152-162 [PMID: 22796337 DOI: 10.1016/j.mce.2012.06.018]
 - 12 **Laemmli UK.** Cleavage of structural proteins during the assembly of the head of bacteriophage T4. *Nature* 1970; **227**: 680-685 [PMID: 5432063]
 - 13 **Towbin H, Staehelin T, Gordon J.** Electrophoretic transfer of proteins from polyacrylamide gels to nitrocellulose sheets: procedure and some applications. *Proc Natl Acad Sci USA* 1979; **76**: 4350-4354 [PMID: 388439]
 - 14 **Romanque P, Cornejo P, Valdés S, Videla LA.** Thyroid hormone administration induces rat liver Nrf2 activation: suppression by N-acetylcysteine pretreatment. *Thyroid* 2011; **21**: 655-662 [PMID: 21563917 DOI: 10.1089/thy.2010.0322]
 - 15 **Vargas R, Ortega Y, Bozo V, Andrade M, Minuzzi G, Cornejo P, Fernandez V, Videla LA.** Thyroid hormone activates rat liver adenosine 5'-monophosphate-activated protein kinase: relation to CaMKKb, TAK1 and LKB1 expression and energy status. *J Biol Regul Homeost Agents* 2013; **27**: 989-999 [PMID: 24382180]
 - 16 **Fernández V, Tapia G, Varela P, Gaete L, Vera G, Mora C, Vial MT, Videla LA.** Causal role of oxidative stress in liver preconditioning by thyroid hormone in rats. *Free Radic Biol Med* 2008; **44**: 1724-1731 [PMID: 18291118 DOI: 10.1016/j.free-radbiomed.2008.01.010]
 - 17 **Harada D, Naito S, Hiraoka I, Otagiri M.** In vivo kinetic analysis of covalent binding between N-acetyl-L-cysteine and plasma protein through the formation of mixed disulfide in rats. *Pharm Res* 2002; **19**: 615-620 [PMID: 12069163]
 - 18 **Moldéus P, Cotgreave IA.** N-acetylcysteine. *Methods Enzymol* 1994; **234**: 482-492 [PMID: 7808322 DOI: 10.1016/0076-6879(94)34119-2]
 - 19 **Zafarullah M, Li WQ, Sylvester J, Ahmad M.** Molecular mechanisms of N-acetylcysteine actions. *Cell Mol Life Sci* 2003; **60**: 6-20 [PMID: 12613655]
 - 20 **Choi SL, Kim SJ, Lee KT, Kim J, Mu J, Birnbaum MJ, Soo Kim S, Ha J.** The regulation of AMP-activated protein kinase by H₂O₂. *Biochem Biophys Res Commun* 2001; **287**: 92-97 [PMID: 11549258 DOI: 10.1006/bbrc.2001.5544]
 - 21 **Woods A, Dickerson K, Heath R, Hong SP, Momcilovic M, Johnstone SR, Carlson M, Carling D.** Ca²⁺/calmodulin-dependent protein kinase kinase-beta acts upstream of AMP-activated protein kinase in mammalian cells. *Cell Metab* 2005; **2**: 21-33 [PMID: 16054096 DOI: 10.1016/j.cmet.2005.06.005]
 - 22 **Park IJ, Hwang JT, Kim YM, Ha J, Park OJ.** Differential modulation of AMPK signaling pathways by low or high levels of exogenous reactive oxygen species in colon cancer cells. *Ann N Y Acad Sci* 2006; **1091**: 102-109 [PMID: 17341607 DOI: 10.1196/annals.1378.059]
 - 23 **Irrcher I, Ljubcic V, Hood DA.** Interactions between ROS and AMP kinase activity in the regulation of PGC-1alpha transcription in skeletal muscle cells. *Am J Physiol Cell Physiol* 2009; **296**: C116-C123 [PMID: 19005163 DOI: 10.14814/phy2.12008]
 - 24 **Corton JM, Gillespie JG, Hardie DG.** Role of the AMP-activated protein kinase in the cellular stress response. *Curr Biol* 1994; **4**: 315-324 [PMID: 7922340 DOI: 10.1016/S0960-9822(00)00070-1]
 - 25 **Kudo N, Barr AJ, Barr RL, Desai S, Lopaschuk GD.** High rates of fatty acid oxidation during reperfusion of ischemic hearts are associated with a decrease in malonyl-CoA levels due to an increase in 5'-AMP-activated protein kinase inhibition of acetyl-CoA carboxylase. *J Biol Chem* 1995; **270**: 17513-17520 [PMID: 7615556 DOI: 10.1074/jbc.270.29.17513]
 - 26 **Winder WW, Hardie DG.** Inactivation of acetyl-CoA carboxylase and activation of AMP-activated protein kinase in muscle during exercise. *Am J Physiol Endocrinol Metab* 1996; **270**: E299-E304
 - 27 **Collins QF, Liu HY, Pi J, Liu Z, Quon MJ, Cao W.** Epigallocatechin-3-gallate (EGCG), a green tea polyphenol, suppresses hepatic gluconeogenesis through 5'-AMP-activated protein kinase. *J Biol Chem* 2007; **282**: 30143-30149 [PMID: 17724029 DOI: 10.1074/jbc.M702390200]
 - 28 **Forman HJ, Maiorino M, Ursini F.** Signaling functions of reactive oxygen species. *Biochemistry* 2010; **49**: 835-842 [PMID: 20050630 DOI: 10.1021/bi.9020378]
 - 29 **Thomson DM, Winder WW.** AMP-activated protein kinase control of fat metabolism in skeletal muscle. *Acta Physiol (Oxf)* 2009; **196**: 147-154 [PMID: 19245653 DOI: 10.1111/j.1748-1716.2009.01973.x]
 - 30 **Zhang X, Grand RJ, McCabe CJ, Franklyn JA, Gallimore PH, Turnell AS.** Transcriptional regulation of the human glycoprotein hormone common alpha subunit gene by cAMP-response-element-binding protein (CREB)-binding protein (CBP)/p300 and p53. *Biochem J* 2002; **368**: 191-201 [PMID: 12164786 DOI: 10.1042/BJ20020634]
 - 31 **Thomson DM, Herway ST, Fillmore N, Kim H, Brown JD, Barrow JR, Winder WW.** AMP-activated protein kinase phosphorylates transcription factors of the CREB family. *J Appl Physiol* 2008; **104**: 429-438 [PMID: 18063805 DOI: 10.1152/jappphysiol.00900.2007]
 - 32 **Shaywitz AJ, Greenberg ME.** CREB: a stimulus-induced transcription factor activated by a diverse array of extracellular signals. *Annu Rev Biochem* 1999; **68**: 821-861 [PMID: 10872467 DOI: 10.1146/annurev.biochem.68.1.821]
 - 33 **Jäger S, Handschin C, St-Pierre J, Spiegelman BM.** AMP-activated protein kinase (AMPK) action in skeletal muscle via direct phosphorylation of PGC-1alpha. *Proc Natl Acad Sci USA* 2007; **104**: 12017-12022 [PMID: 17609368 DOI: 10.1073/pnas.0705070104]
 - 34 **Schmidt SF, Mandrup S.** Gene program-specific regulation of PGC-1{alpha} activity. *Genes Dev* 2011; **25**: 1453-1458 [PMID: 21764849 DOI: 10.1101/gad.2076411]
 - 35 **Vega RB, Huss JM, Kelly DP.** The coactivator PGC-1 coop-

- erates with peroxisome proliferator-activator receptor α in transcriptional control of nuclear genes encoding mitochondrial fatty acid oxidation enzymes. *Mol Cell Biol* 2000; **20**: 1868-1876 [DOI: 10.1128/MCB.20.5.1868-1876.2000]
- 36 **Aoyama T**, Souri M, Kamijo T, Ushikubo S, Hashimoto T. Peroxisomal acyl-coenzyme A oxidase is a rate-limiting enzyme in a very-long-chain fatty acid beta-oxidation system. *Biochem Biophys Res Commun* 1994; **201**: 1541-1547 [PMID: 8024599 DOI: 10.1006/bbrc.1994.1879]
- 37 **Kirkby B**, Roman N, Kobe B, Kellie S, Forwood JK. Functional and structural properties of mammalian acyl-coenzyme A thioesterases. *Prog Lipid Res* 2010; **49**: 366-377 [PMID: 20470824 DOI: 10.1016/plipres.2010.04.001]
- 38 **Ismail-Beigi F**, Salibian A, Kirsten E, Edelman IS, White A. Effects of thyroid hormone on adenine nucleotide content of rat liver. *Proc Soc Exp Biol Med* 1973; **144**: 471-474 [PMID: 4746919]
- 39 **Sinha RA**, You SH, Zhou J, Siddique MM, Bay BH, Zhu X, Privalsky ML, Cheng SY, Stevens RD, Summers SA, Newgard CB, Lazar MA, Yen PM. Thyroid hormone stimulates hepatic lipid catabolism via activation of autophagy. *J Clin Invest* 2012; **122**: 2428-2438 [PMID: 22684107 DOI: 10.1172/JCI160580]
- 40 **Pantos CI**, Malliopoulou VA, Mourouzis IS, Karamanoli EP, Paizis IA, Steimberg N, Varonos DD, Cokkinos DV. Long-term thyroxine administration protects the heart in a pattern similar to ischemic preconditioning. *Thyroid* 2002; **12**: 325-329 [PMID: 12034058 DOI: 10.1089/10507250252949469]
- 41 **Kumar A**, Taliyan R, Sharma PL. Evaluation of thyroid hormone induced pharmacological preconditioning on cardiomyocyte protection against ischemic-reperfusion injury. *Indian J Pharmacol* 2012; **44**: 68-72 [PMID: 22345873 DOI: 10.4103/0253-7613.91870]
- 42 **Li F**, Lu S, Zhu R, Zhou Z, Ma L, Cai L, Liu Z. Heme oxygenase-1 is induced by thyroid hormone and involved in thyroid hormone preconditioning-induced protection against renal warm ischemia in rat. *Mol Cell Endocrinol* 2011; **339**: 54-62 [PMID: 21458530 DOI: 10.1016/j.mce.2011.03.019]
- 43 **Ferreira C**, O'Valle F, Osorio JM, Moreno JM, Rodríguez I, Vargas F, Osuna A. Effect of preconditioning with triiodothyronine on renal ischemia/reperfusion injury and poly(ADP-ribose) polymerase expression in rats. *Transplant Proc* 2009; **41**: 2073-2075 [PMID: 19715835 DOI: 10.1016/j.transproceed.2009.06.060]
- 44 **Genovese T**, Impellizzeri D, Ahmad A, Cornelius C, Campolo M, Cuzzocrea S, Esposito E. Post-ischaemic thyroid hormone treatment in a rat model of acute stroke. *Brain Res* 2013; **1513**: 92-102 [PMID: 23500636 DOI: 10.1016/j.brainres.2013.03.001]

P- Reviewer: Ikura Y, Lu WY S- Editor: Qi Y L- Editor: A
E- Editor: Zhang DN





Published by **Baishideng Publishing Group Inc**

8226 Regency Drive, Pleasanton, CA 94588, USA

Telephone: +1-925-223-8242

Fax: +1-925-223-8243

E-mail: bpgoffice@wjgnet.com

Help Desk: <http://www.wjgnet.com/esps/helpdesk.aspx>

<http://www.wjgnet.com>



ISSN 1007-9327



9 771007 932045