



Miniaturized Broadband Circularly Polarized Microstrip Antenna for WLAN

¹Jibendu Sekhar Roy*, ¹Milind Thomas and ²Jayanta Ghosh

¹Department of Electronics and Communication Engineering
Birla Institute of Technology (Deemed University), Mesra, Ranchi-835215, India.

²Department of Electronics and Communication Engineering
Asansol Engineering College, Asansol, WB, India
Tel: 91-651-2275-750; Fax: 91-651-2275-401; E-mail: drjsroy@rediffmail.com

Abstract- The design of a proximity coupled microstrip antenna, for the application in Wireless Local Area Network (WLAN) is reported here. This miniaturized circularly polarized microstrip antenna has required wide bandwidth for practical application. The simulated results using IE3D software, agree well with the measured results.

Index Terms- Miniaturized, broadband, circular polarization, HIPERLAN/2, proximity coupled microstrip antenna.

I. INTRODUCTION

The need for wireless broadband communications has increased rapidly in recent years demanding quality of service, security, handover, and increased throughput for the wireless local area networks (WLANs). The main aim of future wireless communication is high speed networking system for multimedia communication. The most important high data rate wireless broadband networking systems for future wireless communications are High Performance Local Area Network type 1 (HIPERLAN/1) and High Performance Local Area Network type 2 (HIPERLAN/2) which use the frequency bands 5.150 GHz – 5.350 GHz and 5.470 GHz – 5.725 GHz respectively, with omni-directional antennas [1]. HIPERLAN/2 has a very high transmission rate up to 54 Mbit/s. Basic services in HIPERLAN/2 are data, sound, and video transmission. The modern wireless communication systems require the antennas for different systems and standards with

characteristics like compact, broadband, multiple resonant frequencies and moderate gain. The circularly polarized antenna is required for this type of communication. Because of many attractive features, microstrip patch antennas have received considerable attention for wireless communication applications [2-12]. The basic structure of a microstrip antenna consists of a metallic radiating patch fabricated on a dielectric substrate and backed by a ground plane. Single layer microstrip antennas have very narrow bandwidth, but using multi-layered configurations, like proximity coupled microstrip antennas or aperture coupled microstrip antennas, higher bandwidth can be achieved [13-17]. The input impedance of a proximity coupled microstrip antenna is a sensitive function of length and width of the microstrip feed line. Since radiation pattern of a microstrip antenna has wide beamwidth in one hemisphere, two back-to-back microstrip antennas in the same module can be used to produce nearly omni-directional radiation pattern required for WLAN applications. Two back-to-back proposed microstrip antennas will be placed vertically to produce radiation patterns with wide beamwidths in two directions. There will be distinct nulls in two opposite directions. The HIPERLAN/2 is principally used for indoor wireless local area network and for indoor signal propagation due to multiple reflections from walls and other human made structures, signal changes its direction and hence signals from other directions except null directions will be received by the receiving antenna. In proximity

coupled microstrip antenna, the radiating patch, fabricated on a dielectric substrate, is excited by a microstrip line on another substrate, as shown in Fig. 1. The dielectric constants and heights of the substrates, used for microstrip patch and microstrip line may be different. Attention has been given to design microstrip patch antennas for communication using HIPERLAN [2], [6-7]. Miniaturized broadband circularly polarized microstrip antennas are most attractive for WLAN applications.

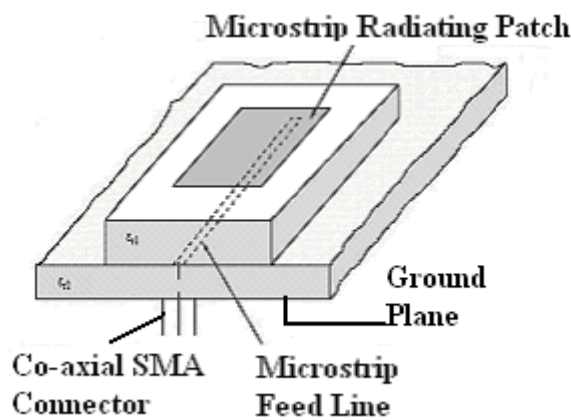

Fig.1. Geometry of proximity coupled microstrip antenna

In this paper, the investigations on a proximity coupled square microstrip antenna in the frequency band of HIPERLAN/2 are reported. Then from this square radiating patch, small isosceles right angle triangular sections are removed from the diagonally opposite corners to produce orthogonal modes in order to produce circular polarization and this technique is used to design circularly polarized single layer patch antennas [5], [16-17]. But for single layer patch antenna, the impedance bandwidth and the axial ratio bandwidth are narrow. Then this truncated square radiating patch is proximity coupled by a microstrip line. Results show that the proposed circularly polarized microstrip patch antenna has very small size, wide bandwidth, moderate gain and very good axial ratio bandwidth required for the communication using HIPERLAN/2.

II. SIMULATED AND MEASURED RESULTS

The geometry of the proximity coupled microstrip antenna is shown in Fig.2.

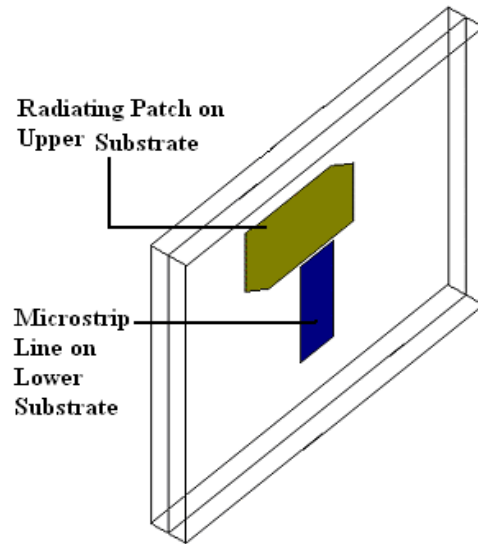

Fig.2. Geometry of the circularly polarized proximity coupled microstrip antenna (the length of the stub line is 4.5 mm)

The dimensions of the patch and the fabricated antenna prototype are shown in and Fig.3a and Fig.3b respectively.

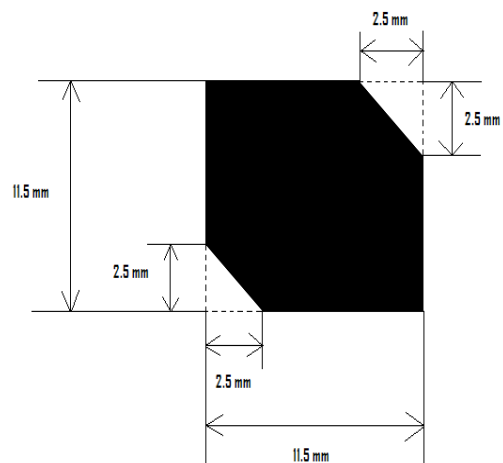

Fig. 3a. The dimensions of the microstrip radiating patch



Fig. 3b. The fabricated antenna prototype

For antenna design, IE3D simulation software (version 10.2) is used, which is a full wave electromagnetic simulation software for the microwave and millimeter wave integrated circuits. The primary formulation of the IE3D software is an integral equation obtained through the use of Green's function. During simulation a large number of microstrip antenna structures of this type with different dimensions (of patch, feed line and truncated portion) are simulated and the best result on the basis of impedance bandwidth, axial ratio bandwidth and gain is described here. Both the microstrip patch and the microstrip feed line were fabricated on Glass Epoxy substrate with dielectric constant 4.36, substrate height 1.57 mm. and loss tangent of 0.001. The microstrip feed line was placed just below the centre of the patch. The microstrip feed line was connected to SMA connector. IE3D simulation takes into account the effect of SMA connector. The length of the microstrip feed line which appears beyond the centre of the

patch, is stub length. For antenna with non-contacting feed, like proximity coupled microstrip antenna, this stub length is important for impedance matching.

The general equivalent circuit of proximity coupled microstrip antenna with the open circuited stub is shown in Fig. 4. The microstrip antenna is considered as an parallel electromagnetic resonator with inductance L , capacitance C and resistance R . The coupling between microstrip patch and microstrip feed line is capacitive in nature and this coupling capacitance is represented by C_c . If the patch is excited by the feed line, placed exactly below the center of the radiating patch, the length of the stub line is zero.

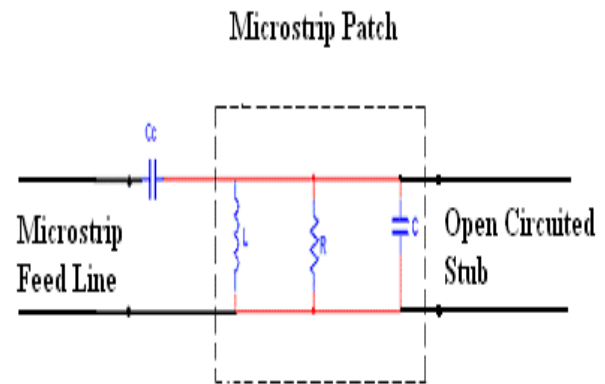

Fig. 4. Equivalent circuit of proximity coupled microstrip antenna

In simulation, the best impedance matching at 5.61 GHz was obtained when the stub length was 4.5 mm and with the truncation of 2.5 mm X 2.5 mm at two opposite corners of the patch (as shown in Fig. 3a), best 3-dB axial ratio bandwidth was obtained. The length of the square patch was 11.5 mm (as shown in Fig. 3a) and the dimensions of the microstrip line were 15 mm X 3.5 mm which was fed by a co-axial SMA connector. The simulated input reflection coefficient of the proximity coupled microstrip antenna is compared with measured result (measured using Vector Network Analyzer, N5230A, Agilent Technologies) in Fig. 5. The

simulated and measured resonance frequencies were 5.61 GHz and 5.62 GHz respectively. The simulated and measured -10 dB return loss impedance bandwidths were 500 MHz and 470 MHz respectively, covering the frequency range of HIPERLAN/2 which is 5.470 GHz – 5.725 GHz. The bandwidth for HIPERLAN/2 communication is 255 MHz.

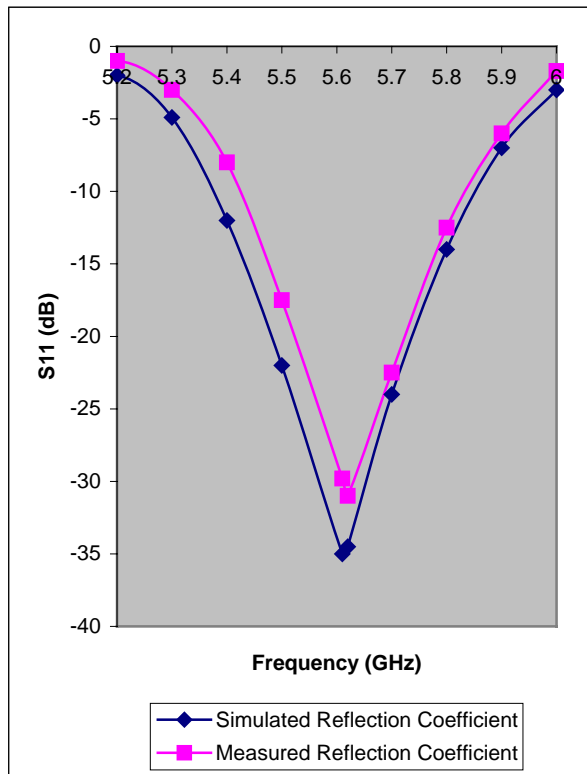

Fig. 5. Simulated and measured reflection coefficients of the antenna

In Fig. 6, the simulated and measured radiation patterns, on two principal planes, are compared. The antenna exhibits circularly polarized broadside radiation patterns. The radiation patterns of the microstrip patch antenna on both the principal planes were measured using C-band (4-8 GHz) waveguide type microwave bench (Vidyut Yantra Udyog, India) and using a standard pyramidal horn as a transmitting antenna.

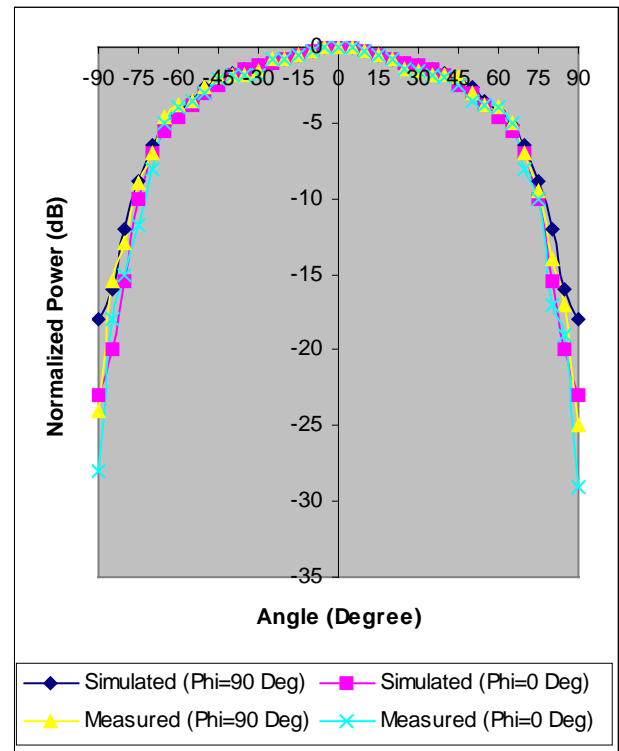

Fig. 6. Simulated and measured radiation patterns of the antenna

Simulation, using IE3D (version 10.2) assumes infinite ground plane whereas in fabricated antenna prototype, the ground plane dimension was 25 mm X 25 mm. The ripples in the measured radiation patterns in Fig. 6, are due to the diffraction effect from the edges of the small ground plane. The gain of the antenna was measured over the frequency range of HIPERLAN/2, using two identical proximity coupled microstrip antennas. Measuring radiated power of the antenna on both the principal planes, axial ratio was determined. The comparison of measured gain and axial ratio with simulated gain and axial ratio are shown in Fig. 7. The gain of the antenna was also measured by the Vector Network Analyzer. In this case two identical dual-frequency proximity coupled microstrip antennas were designed to use as transmitting and receiving antennas and transmission coefficient (S_{21}) was measured [10]. The two antennas were separated by a distance 'r' which must be more than the minimum distance to receive far field. One antenna was

connected to the port 1 of the network analyzer and other antenna was connected to the port 2 of the network analyzer. That is, one antenna was treated as transmitting antenna and the other was treated as receiving antenna.

The transmitted power (P_t) and the received power (P_r) can be related to the S_{21} by the expression

$$P_r/P_t = |S_{21}|^2$$

Then Friis transmission formula can be re-written as

$$|S_{21}|^2 = (G_r^2 \lambda^2) / (4\pi r)^2$$

where gain of transmitted antenna (G_t) and received antenna (G_r) are same and λ is the wavelength corresponding to the frequency of measurement. That is, gain of the receiving antenna is

$$G_r = (4\pi r / \lambda) |S_{21}|$$

The minimum simulated gain over the frequency range of HIPERLAN/2 is 4.7 dBi with a maximum value of 5.1 dBi at the frequency of 5.61 GHz. The simulated 3-dB axial ratio bandwidth is 280 MHz and measured 3-dB axial ratio bandwidth is 260 MHz.

The high impedance bandwidth and axial ratio bandwidth, achieved using this proposed proximity coupled microstrip antenna, can not be achieved by using a single layer microstrip antenna. Square single layer microstrip antenna, truncated in one of the corners and excited by coaxial SMA connector was simulated and measured. In this case dimension of the square patch, on the same type of substrate, was 12.4 mm X 12.4 mm and the truncated dimension was 2.7 mm X 2.7 mm. The simulated -10 dB return loss bandwidth and 3-dB axial ratio bandwidth of the antenna, at the frequency range of HIPERLAN/2 were 300 MHz (measured value 285 MHz) and 72 MHz (measured value 60 MHz) respectively. The simulated gain of the

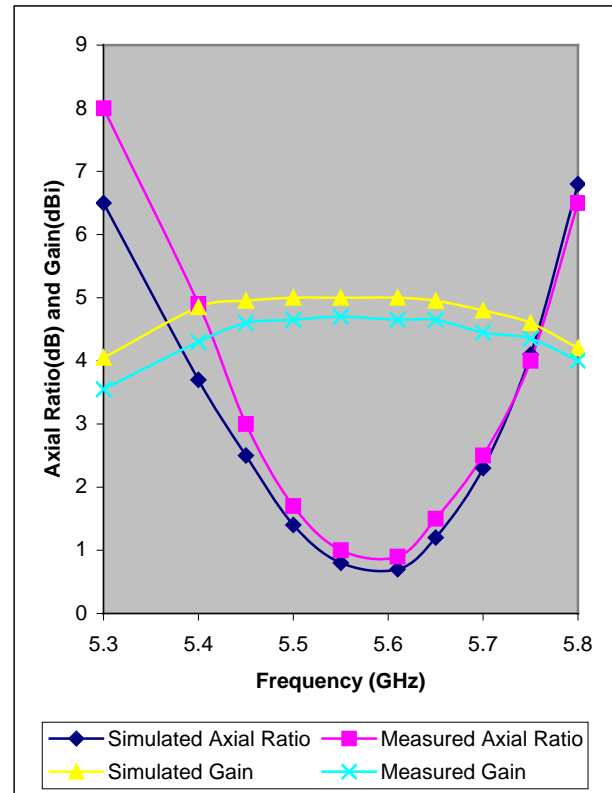

Fig. 7. The comparison of simulated and measured axial ratio and gain of the proximity coupled microstrip patch antenna

antenna, at the center frequency of 5.55 GHz, was 5.25 dBi. For proposed antenna due to proximity coupling and due to truncation in both the corners, the dimension of the patch was reduced to 11.5 mm X 11.5 mm. Thus in proposed structure, the peripheral dimension of the patch was reduced by about 15 %.

At the HIPERLAN/2 frequency band, the variations of return loss bandwidth and axial ratio bandwidth of the proposed antenna with the variation of length of the stub line are tabulated in Table 1. The maximum bandwidths for those parameters were obtained when length of the stub line was 4.5 mm.

Table 1: Simulated results for the performances of proposed microstrip antenna with the variation of length of the stub line

Proposed Square proximity coupled microstrip antenna with patch dimension 11.5 mm and truncated in both the corners with truncated dimension of 2.5 mm X 2.5 mm. Microstrip line dimension 15 mm X 3.5 mm.		
Stub length, mm	-10dB return loss bandwidth, MHz	3dB axial ratio bandwidth, MHz
0	45	60
1.5	155	125
2.5	230	195
4	450	260
4.5	500	280
5	430	255
6.5	210	200

At the above frequency band (5.61 GHz), the variations of return loss bandwidth and axial ratio bandwidth of the proposed antenna with the variation of corner truncation dimension are shown in Table 2. The maximum bandwidths for those parameters were obtained when the truncation dimension was 2.5 mm X 2.5 mm.

Table 2: Simulated results for the performances of proposed microstrip antenna with the variation of truncated corner dimension

Proposed Square proximity coupled microstrip antenna with patch dimension of 11.5 mm and truncated in both the corners with microstrip line dimension of 15 mm X 3.5 mm and stub length of 4.5 mm.		
Truncation dimension	-10dB return loss bandwidth, MHz	3dB axial ratio bandwidth, MHz
1.5 mm X 1.5 mm	410	100
2.0 mm X 2.0 mm	465	230
2.5 mm X 2.5 mm	500	280
3.0 mm X 3.0 mm	470	220
3.5 mm X 3.5 mm	415	85

The small differences between simulated and experimental results, in all the cases, due to the fact that multi-layered fabrication is not used for the design of the antenna module. The patch was designed on one substrate and microstrip line was designed on another substrate and then these two were pasted by a thin gum. The gain and

radiation patterns of the antenna were not measured in anechoic chamber.

III. CONCLUSION

The design of a miniaturized circularly polarized proximity coupled microstrip antenna, for the application in WLAN is described. Simulated and measured results show that the impedance bandwidth and axial ratio bandwidth of the antenna are very good and may be used for wireless networking using HIPERLAN/2. Cutting slot on the patch, the peripheral size can be reduced further.

ACKNOWLEDGMENT

The authors like to acknowledge University Grants Commission (UGC), New Delhi for providing research facilities during this work.

REFERENCES

- [1] R. V. Nee and R. Prasad, "OFDM for Wireless Multimedia Communications", Artech House, 2000.
- [2] Y. J. Guo, A. Paez, R. A. Sadeghzadeh and S. K. Barton, "A Patch Antenna for HIPERLAN", *Wireless Personal Communications*, vol 3, pp. 389-396, 1996.
- [3] J. Ollikainen, M. Fischer and P. Vainikain, "Thin Dual-resonant Stacked Shorted Patch Antenna for Mobile Communications", *Electronics Letters*, vol 35, 1999, pp. 437-438, 1999.
- [4] F. Yang, X-X Zhang, X. Ye and Y. Rahmat-Samii, "Wide-Band E-Shaped Patch Antennas for Wireless Communications", *IEEE Trans. Antennas and Propagation*, vol AP- 49, pp. 1094 - 1100, 2001.
- [5] R. Garg, P. Bhartia, I. J. Bahl, A. Ittipiboon, *Microstrip Antenna Design Handbook*, Artech House, 2001.
- [6] Y-L Kuo and K-L Wong, "Printed Double-T Monopole Antenna for 2.4/5.2 GHz Dual-Band WLAN Operations", *IEEE Trans. Antennas and Propagation*, Vol. AP-51, pp. 2187 - 2192, 2003.

- [7] Q. Zhong; Y. Li, H. Jiang and Y. Long, "Design of a Novel Dual-Frequency Microstrip Patch Antenna for WLAN Applications", *IEEE Antennas and Propagation Society International Symposium*, vol 1, pp. 277 – 280, June 2004.
- [8] J. S. Roy, N. Chattoraj and N. Swain, "Short Circuited Microstrip Antennas For Multi-band Wireless Communications", *Microwave and Optical Technology Letters*, vol 48, pp. 2372 – 2375, 2006.
- [9] J. S. Roy, N. Chattoraj and N. Swain, "New Dual-Frequency Microstrip Antennas for Wireless Communication", *Romanian Journal of Information Science and Technology*, vol 10, pp. 113 – 119, 2007.
- [10] J. S. Roy and M. Thomas, "Theoretical and Experimental Investigations on a New Proximity Coupled Dual Frequency Microstrip Antenna for the Application in Wireless Communication", *Microwave Review*, Vol.13, pp. 12–15, June 2007.
- [11] J. S. Roy and M. Thomas, "Compact and Broadband Microstrip Antennas for Next Generation High Speed Wireless Communication Using HIPERLAN/2", *Intl. Jnl. of Microwave Science and Technology*, Vol. 2007, No.10, pp.1-4, 2007.
- [12] M.Thomas, J. Ghosh and J.S. Roy, "Performances of Two Compact Broadband Slot-Loaded Proximity-Coupled Microstrip Antennas for HIPERLAN/2 Application", *Int. Jnl. of HIT Trans. Electronics, Communication, Computer and Networks (India)*, (To be published) .
- [13] D. M. Pozar and S. M. Voda, "A Rigorous Analysis of a Microstrip Fed Patch Antenna", *IEEE Trans Antennas and Propagation* , vol 35, pp. 1343 – 1350, 1987.
- [14] J. S. Roy, S. K. Shaw, P. Paul, D. R. Poddar and S. K. Chowdhury, "Some Experimental Investigations on Electromagnetically Coupled Microstrip Antennas on Two Layer Substrates", *Microwave and Optical Technology Letters*, vol 4, pp. 236-238, 1991.
- [15] S. M. Duffy, "An Enhanced Bandwidth Design Technique for Electromagnetically Coupled Microstrip Antennas", *IEEE Trans Antennas and Propagation*, vol 48, pp. 161–164, 2000.
- [16] K. L. Wong, *Compact and Broadband Microstrip Antennas*, Wiley, 2002.
- [17] G. Kumar and K. P. Roy, *Broadband Microstrip Antennas*, Artech House Boston, 2003.