

Investigation of different operating modes of ultrasonic annular array used in ophthalmology

M. Urnavičius¹, E. Jasiūnienė¹, R. Raišutis¹, O. Tumšys¹, A. Paunksnis²

¹Ultrasound Institute, Kaunas University of Technology, Studentų 50, 51368 Kaunas, LITHUANIA

²Lithuanian University of Health Sciences Eye clinic

Abstract

The early-stage diagnosis of malignant tumours in eye is very important in ophthalmology in order metastasis of cancer could be prevented and the human life could be saved. Ultrasonography of eye is used already for some time and as it possesses no risk to a patient health it can be repeatedly performed for following of the disease progression.

In order to get as much as possible valuable information about the tumours and their structure it is necessary to create new methods and instruments for extraction of qualitative and valuable information from the received ultrasonic signals. In order to overcome limitations of the existing equipment the new knowledge concerning interaction of ultrasonic waves with intraocular tissue and back-scattering from the tissue affected by the tumour are necessary to be collected. For example, for optimization of the design and operation performance of ultrasonic annular arrays, numerical simulation can be performed.

The objective of this research was to investigate using CIVA software different possibilities of beam focusing in eye using on ultrasonic annular array and to find the optimal solution, which can be used in practice. The ultrasonic fields focused at different distances from the transducer are presented. The propagation of the ultrasonic wave in the eye with tumour and without has been simulated. The simulated and experimental B-scans of the healthy eye and the eye affected by tumour are presented as well. The presented results demonstrate that it is possible to locate malignant tumours in the eye using the optimised ultrasonic annular array.

Keywords: ultrasonic imaging, annular array, CIVA.

Introduction

Tumour in the eye – the ocular melanoma forms at the back of the eye (retina). Its cause is unclear, because this area of the eye is well protected from the harmful wavelengths of sunlight radiation. Melanoma at the early stage isn't a malignant tumour, it doesn't spread to internal organs until it has progressed through certain growth phases. So it is very important to detect melanoma in early phase as soon as possible, before it begin to grow and spread as the metastasis of tumour into the deeper tissues [1].

There are a lot of different types of eye imaging techniques, which are used to investigate the eye from inside [2, 3]: computed tomography (CT); optical coherence tomography (OCT); magnetic resonance imaging (MRI); ultrasound imaging. The cheapest and most health friendly medical imaging system is based on ultrasound. It can be used to find melanoma in the eye. The ultrasonic probe is placed on the eye, and then the high frequency ultrasonic pulse is emitted to the tissue of the eye. Ultrasonic signal is partially reflected from a boundary between different structures of tissue and partially transmitted to the deeper tissues. From reflected signals that contain information about amplitude of the reflected signal and the delay time, the A-scan and B-scan images of the eye can be formed for a further analysis [2].

Nowadays the ultrasonic arrays became very popular in daily ophthalmology. Ultrasonic arrays are made of a number of small transducers, which can be excited independently using the appropriate law. There are four main types of ultrasonic arrays: linear; annular; matrix and circular. Arrays become popular because of their advantages like electronic scanning – which allows to replace mechanical scanning; electronic focusing – which

is based on the use of different electronic delays of excitation of array elements, in order to change the focus point in depth; deflection of ultrasonic beam– which is controlled by modifying the delay law of the excitation of transducer elements in order to change the steering angle of ultrasonic beam. In ophthalmology mainly the linear and the annular arrays are used.

The ultrasonic annular array has fewer elements than a linear, but because it's made of a set of rings, it can be used to focus at different depth along the acoustical axis. Dynamic depth focusing is possible as well. So it's useful for measurements in different depth of the eye. However, in case of an annular array the beam steering cannot be done electronically and the mechanical part (micro scanner) has to be used too.

The model of the eye

In order to analyse the internal structure of the human eye (Fig. 1, a) the simplified computer model of the healthy eye was developed (Fig. 1, b). The simplified model of the eye without tumour was approximated as a sphere, with the parameters of eye vitreous. In Table 1 the parameters of different media (water, vitreous and tumour), used for modelling are presented (thickness, density, velocity of longitudinal waves, attenuation).

The attenuation of the ultrasonic signals in the model was defined by exponential attenuation law:

$$\alpha(f) = \alpha_0 \left(\frac{f}{f_0} \right)^p \quad (1)$$

where f is the frequency at which annular array is operating; α_0 is the attenuation value of the tissue measured at frequency f_0 ; p is the power of the frequency.

Table 1.

	Density, g/cm^3	Parameters of longitudinal wave			
		Velocity of longitudinal wave, m/s	Attenuation, dB/mm	Power of the frequency, p	Frequency at which attenuation is measured, MHz
Vitreous	1	1525	0,06	2	6
Water	1	1483	0	4	1
Tumour	1	1600	0,04	2	10

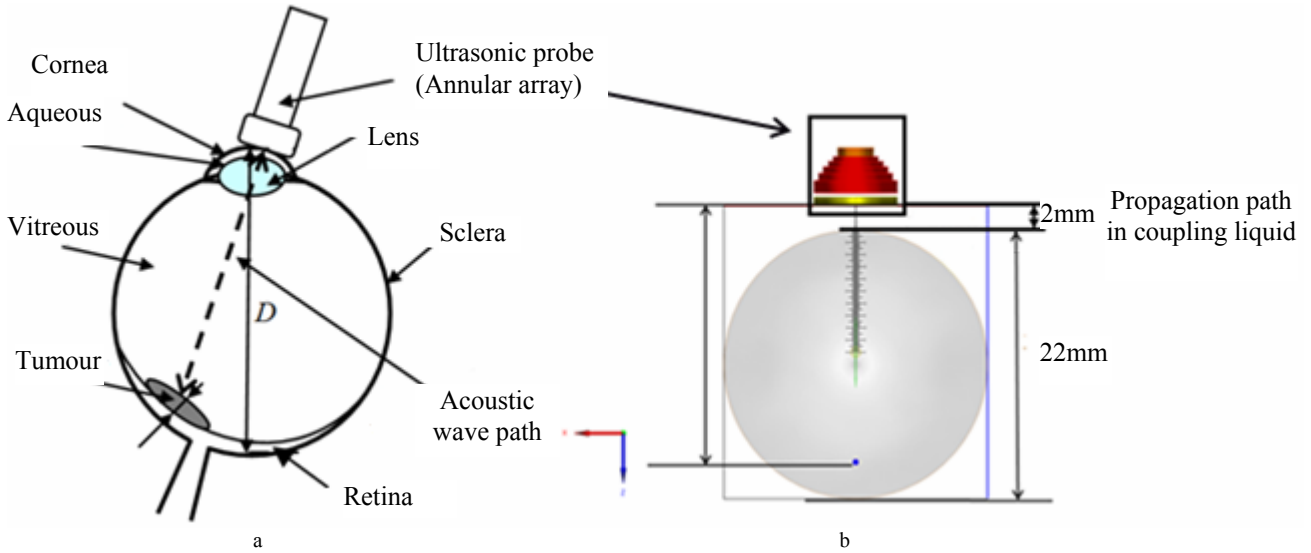

Fig.1. a – The structure of the eye, b – the simplified computer model of the healthy eye

The ultrasonic annular array

The geometry of the ultrasonic annular array used for modelling is shown in Fig. 2. It is an annular phased array, consisting of 6 rings. The outer radius of the array is 3,5 mm, the space between annular array elements was 0,1 mm and the radius of the central element was 1,5 mm.

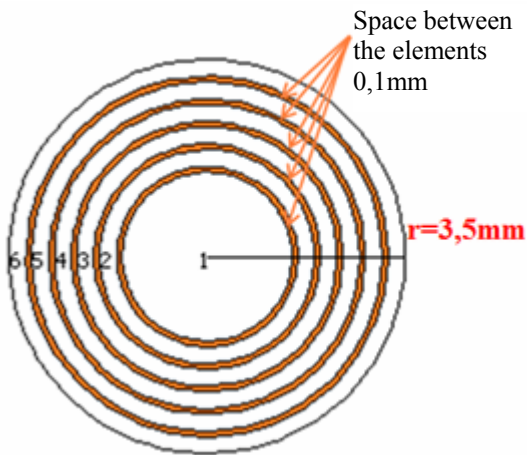

Fig.2. Ultrasonic annular array used for modelling

The central frequency of the array is 10 MHz. The transducer was excited using the Gaussian shape pulse of 10 MHz with 85% bandwidth. The waveform of the excitation signal is presented in Fig.3.

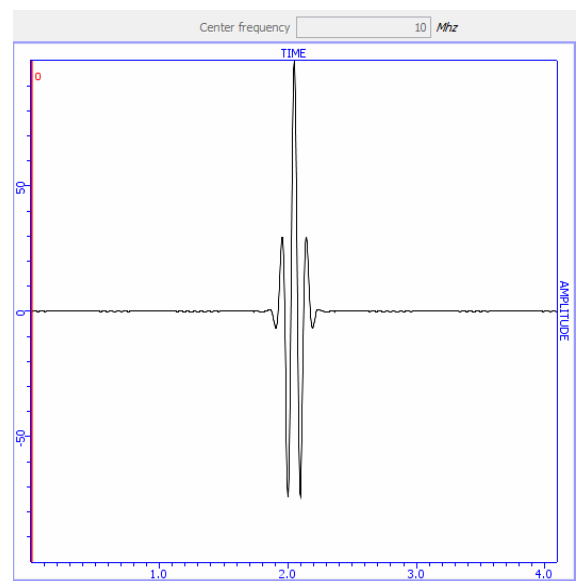

Fig.3. Waveform of excitation signal

Modelling of ultrasonic fields

The modelling of ultrasonic fields in the emission mode was performed at different focal depths. The annular array was placed on the top of the specimen of the eye with 2 mm of coupling medium (water) in between. The annular array was focused at 15 mm (Fig. 4, a.) and 19 mm (Fig. 4, b.) and the transmitted fields were calculated.

The focal zones at -6 dB were calculated. Dimensions of it were the following: for the focal depth of 15 mm the focal zone was 8,1x0,5 mm, for the depth of 19 mm the focal zone was longer - 9,7x0,6 mm. It should be noticed that when the focus point is going deeper, the focal zone is getting longer.

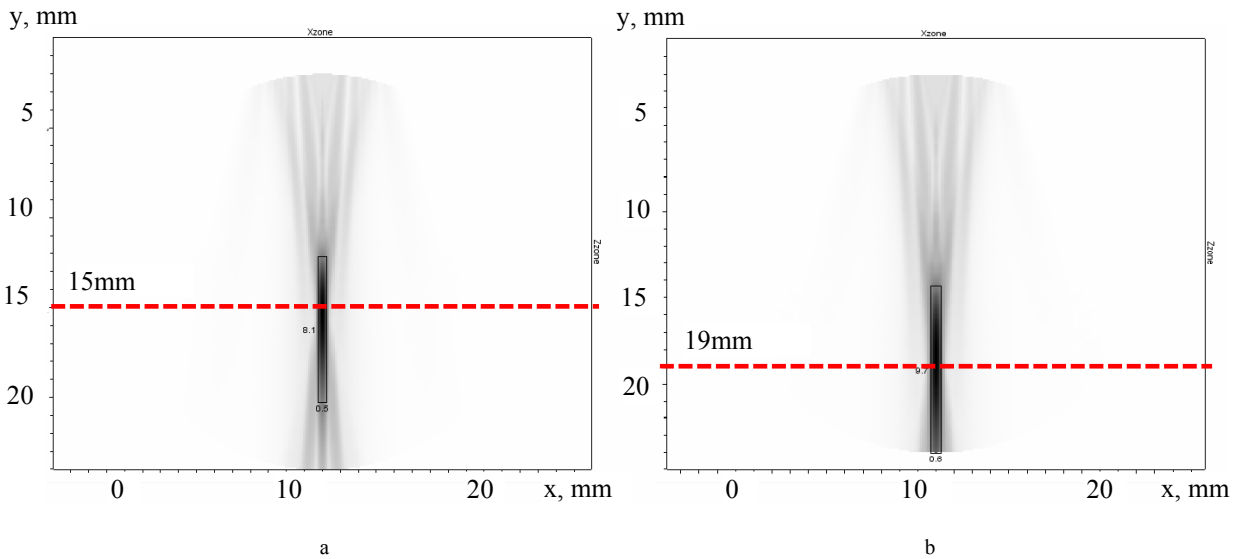

Fig.4. Ultrasonic fields of annular array with different focal depth: a - 15mm; b - 19mm.

Investigation of different reception patterns

Different reception patterns of the ultrasonic annular array were investigated. In emission mode all elements of the ultrasonic annular array were used, but in a receiving mode, two different modes were investigated. In the first case all elements were used to receive signals (Fig. 5, b), in the second case just the central element was used (Fig. 5, c).

In both cases the annular array was focused to 19 mm depth and the received ultrasonic fields were calculated. Comparison of ultrasonic fields using different reception patterns are presented in (Fig. 6.)

When all elements of the array are used for reception the received signal is stronger by 13 dB in comparison when only the central element is used for reception (Fig. 7.)

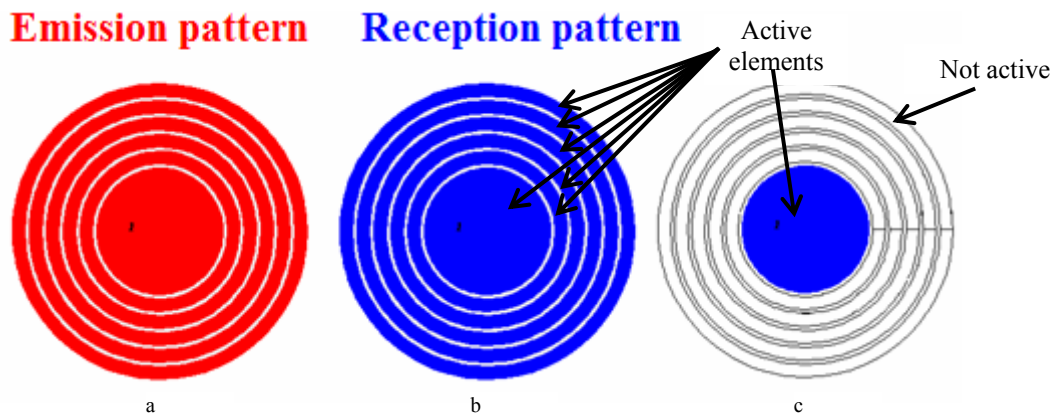

Fig.5. Emission and reception patterns: a – emission pattern, b – reception pattern with all active elements, c – reception pattern with one active element (central disk)

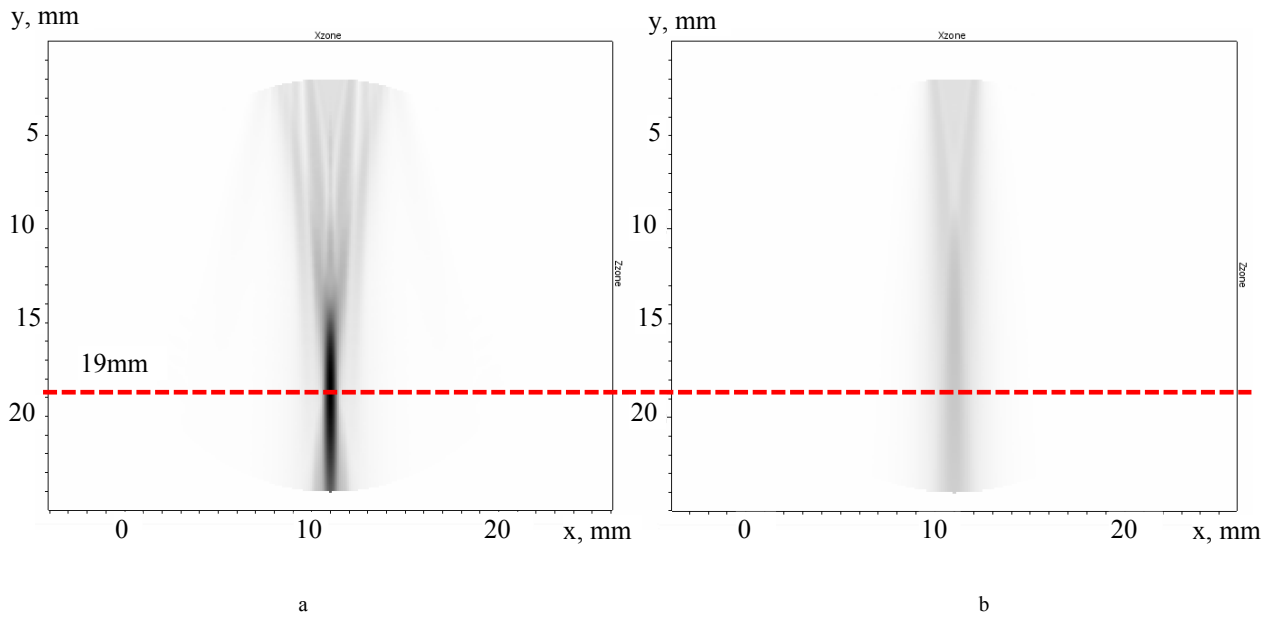

Fig.6. Received ultrasonic fields, when all elements are used for reception (a); just central element is used for reception (b)

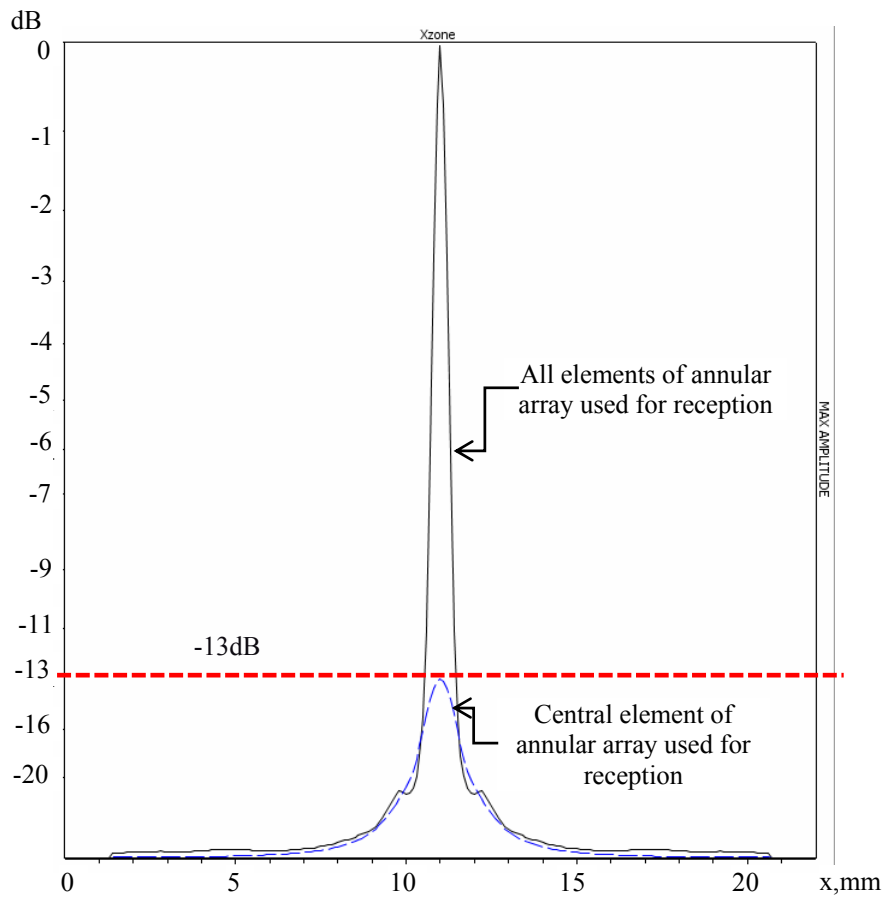

Fig.7. Comparison of amplitude for two reception modes

The model of the eye with tumour

Tumours in the eye are classified according to their sizes (Table 2). Most important is to detect the tumour in the early stage, i.e., when it is small, in order to prevent its further dangerous progression. Therefore a small tumour was included into the model of the eye (Fig. 8). The tumour zone was added at the back of the vitreous, with 1,56 mm thickness and 7,5 mm basal diameter. The parameters of the tumour used for modelling are presented in Table 1.

Table 2. Size of the tumours in the eye [6].

Tumours	Tumour thickness, mm	Tumour basal diameter, mm
Small	< 3mm	< 10 mm
Medium	3 – 5 mm	≤ 15mm
Large	5 – 10 mm	≤ 20 mm
Extra-large	≥ 10mm	> 20 mm

The influence of the attenuation of the signal was investigated. The model of the eye with a tumour in it was used to model signal losses due to attenuation in the eye. The transmitted ultrasonic field of the annular array when attenuation is not taken into account is presented in Fig. 9a and when is taken into account is presented in Fig. 9b.

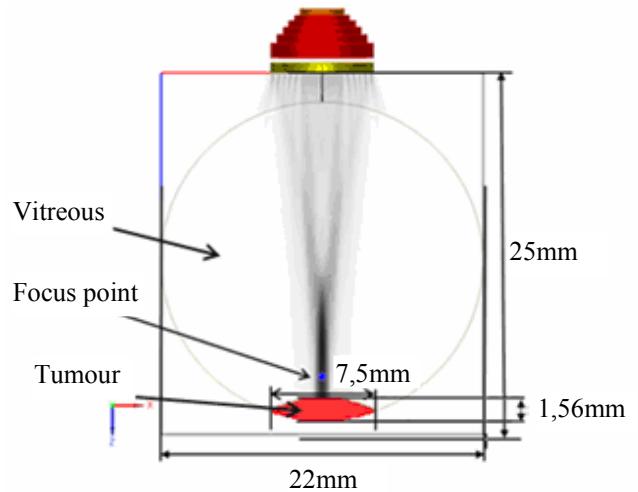

Fig.8. Model with a tumour in the eye

The amplitude of the transmitted signal was compared at the focal depth of 19 mm in both cases, and the difference was -7 dB (Fig. 10.)

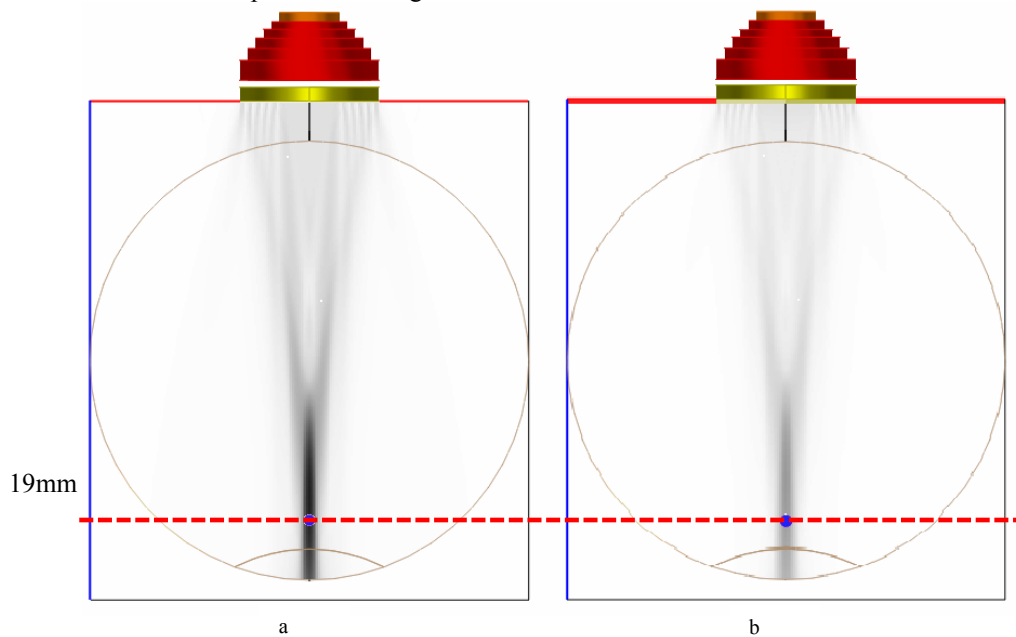

Fig.9. Ultrasonic transmitted field: a - without attenuation; b - attenuated

Modelling using sector scanning

To make imitation of real ultrasonic eye scanning, the model using sector scanning has been developed. The annular array was positioned 4 mm above the eye (4 mm of coupling medium – water). In this model, the annular array was positioned at the central position but with a variable scanning angle. The starting position of the array was -23,2°. The array was scanned by 116 steps, the single step

was 0,4°, the final position was at the +23,2° (Fig. 11). The focus point was 19 mm in depth.

Once again, two operating modes of the array were investigated. All annular array elements were used to transmit signals, but in the reception two different modes were used as well. The first time all elements were used to receive signals (Fig. 12a), the second time just the central element was used (Fig. 12b).

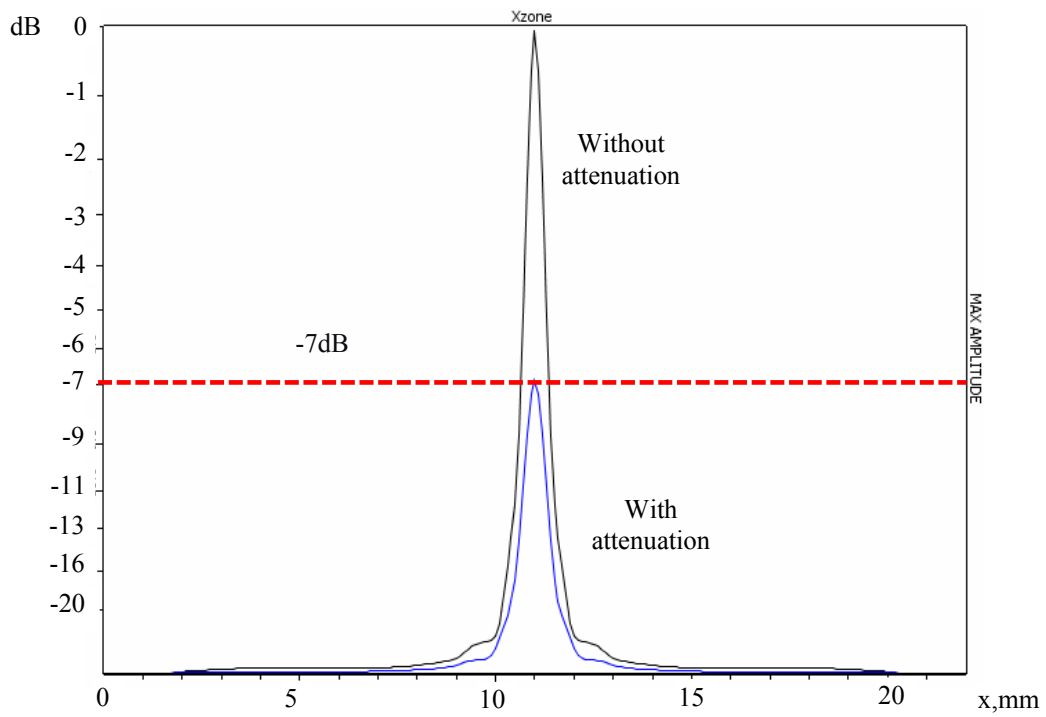

Fig.10. Amplitude difference when attenuation was taken into account at the focal point of 19 mm

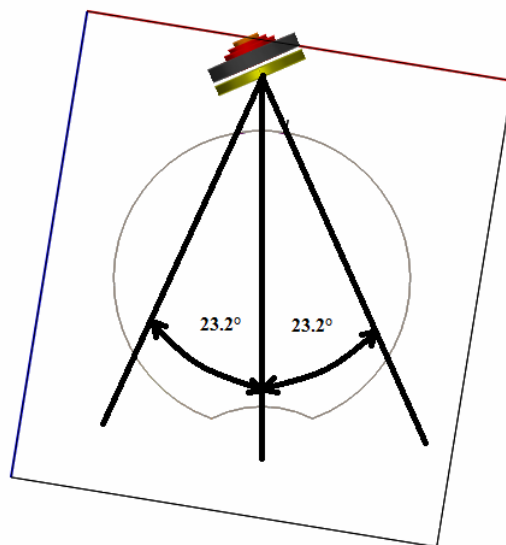

Fig.11. Sector scanning model

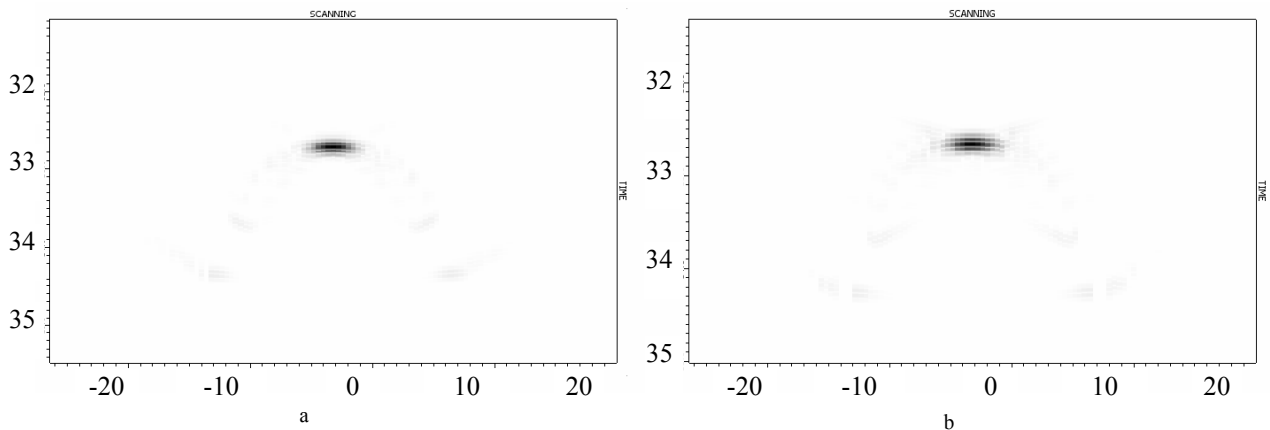

Fig. 12. Sector scan results: a 0 all elements were used for reception; b - only the central element was used for reception

The signal amplitude was compared in both cases, and results show, that the signal amplitude at the central position of the annular array is less by 10dB when just the

central element of the annular array is used for reception (Fig. 13.)

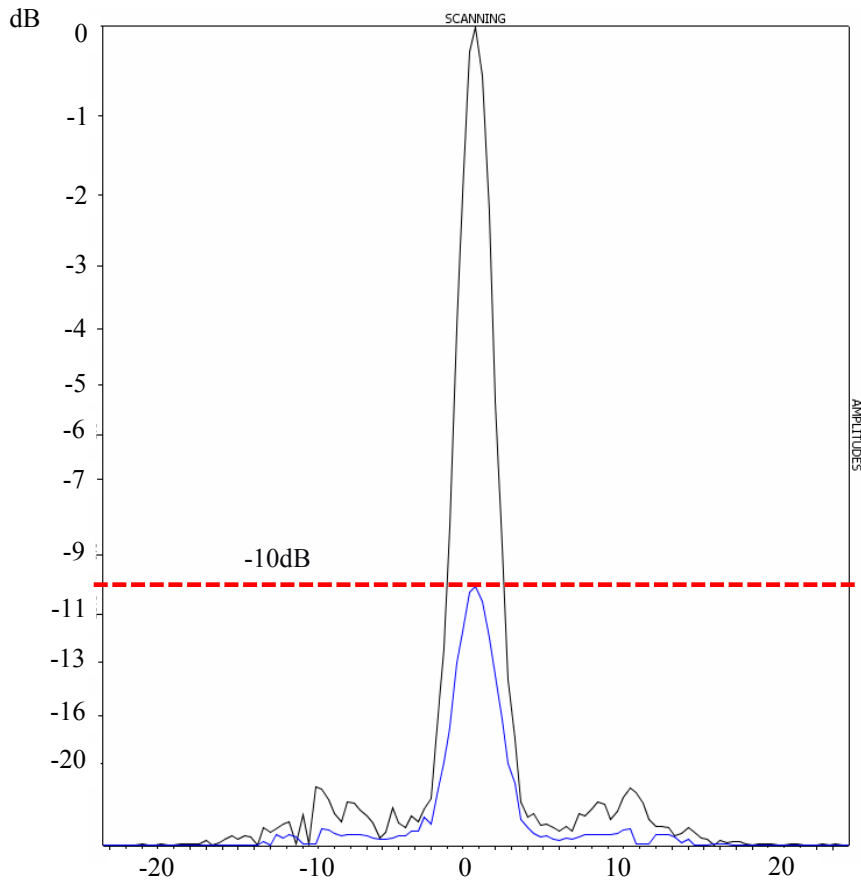

Fig.13. Echo-dynamic curve, signal amplitude difference at central position

Experimental verification

The experimental verification of the modelling results was performed using ultrasonic imaging system-attachment for diagnosis of the eye structure, which was proposed in [5]. The diagnostic system consists of the conventional ophthalmological scanner, the ultrasonic probe (annular array), the splitter for acquisition of raw signals, the preamplifier for initial amplification and the main data acquisition unit for digitization of pre-processing and transferring to a computer for the storage. The experimental set-up of the diagnostic system with ultrasonic imaging system-attachment is presented in Fig.14.

The portable data acquisition system-attachment includes the ARM9 family-based embedded computer, programmed for acquisition of a whole B-scan frame, the time interleaved analog-digital converter, preamplifier, amplifier with the time varying gain, the user selectable matrix of the band-pass filters in the frequency band of 5..40 MHz and FPGA chip for control of synchronous sampling of reflected ultrasonic signals.

The basic ultrasonic scanning of the eye was performed with a conventional ophthalmological echoscope. The ultrasonic probe of this scanner was

excited by a pulse having the central frequency of 10 MHz. The measured conventional B-scan was visualised on the screen of the ophthalmological echoscope. For a further processing and analysis of the RF signals, they were transmitted to the signal capturing and processing system-attachment via appropriate splitting connector. The B-scan images reconstructed from the acquired ultrasonic RF signals reflected from the eyes without and with tumour are presented in Fig.15a and b.

Conclusions

The investigation of optimal operating mode of the ultrasonic annular array used in ophthalmology was performed. The investigation zone was at the back of the eye where melanoma tumours can exist. Because of that, a focused ultrasonic beam was used in a transmission mode, in order to focus the ultrasonic waves at the depth of the investigation zone. Two different reception modes of the annular array were investigated – when all elements and just the central element are active. Results had shown that at least -10dB signal loss is to be expected when signals are received using just the central element of the annular array.

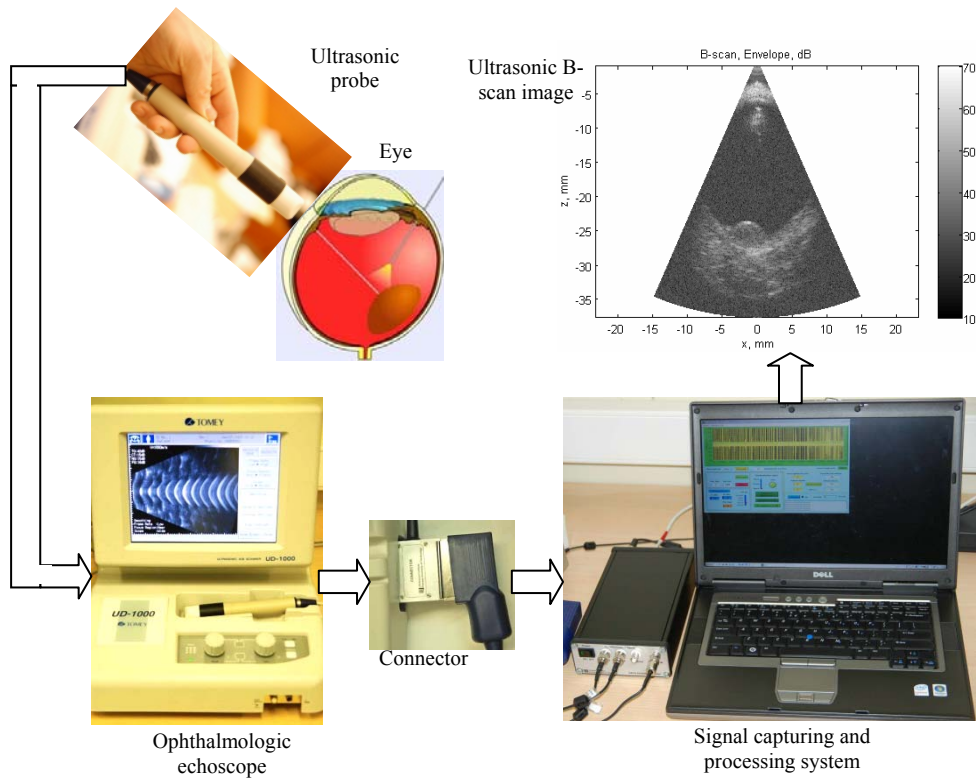

Fig.14. The experimental set-up for investigation of the eye tumours with conventional ophthalmological scanner and the ultrasonic imaging system-attachment.

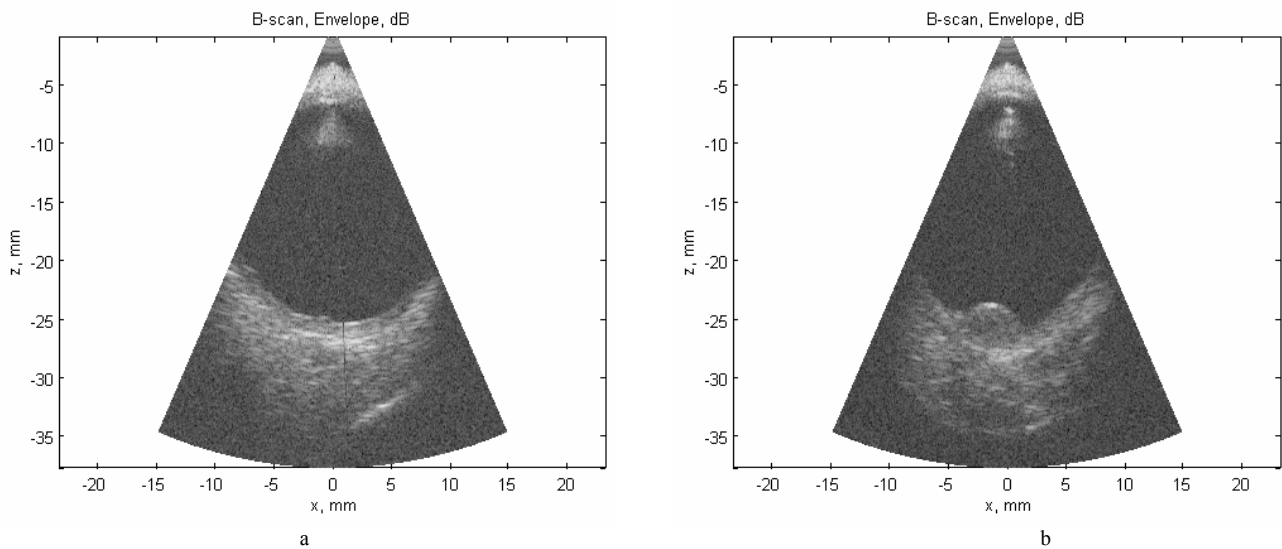

Fig.15. The B-scan images of the healthy eye (a) and the eye with a tumor (b).

The tumour in the eye can be detected also in the case when only the central element of annular array is used for reception. The benefit of central element application is related to a wider spatial coverage of the internal structure of the eye due to a wider directivity pattern in a reception mode.

References

1. **Pope D. C.** Melanoma: Prevention. Detection and Treatment. Yale University Press. 2005. P.204.
2. **Acharya U., Rajendra Ng., Eddie Y. K. Suri, Jasjit S.** Image modeling of the human eye. Artech House publisher. 2008. P. 337.
3. **Rajendra Acharya U., Wong Li Yun, E. Y. K. Ng, Wenwei Yu, Jasjit S. Suri.** Imaging systems of human eye: A Review: Journal of Medical Systems. 2007. Vol.32. No. 4. P.301-315.
4. **Jérôme Poguet, Imasonic S.A. Jérôme Marguet, Imasonic S.A. Fabrice Pichonnat, Imasonic S.A. Laurent Chupin, Imasonic S.A.** Phased Array technology: concepts, probes and applications. The e-Journal of Nondestructive Testing. Kirchwald. NDT.Net. ISSN 1435-4934. 2002. Vol. 7. No. 5. P. 1-5.

5. **Raišutis R., Tumšys O., Deksnys V.** The prototype of ultrasonic imaging system–attachment for diagnosis of human eye tumours. *Ultragarsas*. 2010. Vol.65. No.2. P.42-46.
6. **Daftari I., Aghaian E., O'Brien J. M., Dillon W., Phillips T.** 3D MRI-based tumor delineation of ocular melanoma and its comparison with conventional techniques. *Med. Phys.* 2005. Vol.32(11). P.3355–3362.

M. Urnavičius, E. Jasiūnienė, R. Raišutis, O. Tumšys, A. Paunksnis

Oftalmologijoje naudojamos spindulinės ultragarsinės gardelės skirtingų darbo režimų tyrimas

Reziumė

Oftalmologams labai svarbu auglius akyse aptikti laiku, kad nesusidarytų vėžinių ląstelių, galinčių daugintis ir išplisti į kitus

biologinius organus. Tačiau jau kurį laiką naudojami ultragarsiniai oftalmologiniai prietaisai apsiriboja tradiciniais vaizdiniais matavimo rezultatų išvedimais (A vaizdas arba B vaizdas).

Kad naudingos informacijos apie susidariusius auglius akyje būtų kuo daugiau, reikia naujų tobesnių metodų, kurie leistų sužinoti daugiau apie tiriamus audinius ir jų struktūrą. Tam reikia papildomų tyrimų, kurie padėtų nustatyti, kaip pasikeičia signalas, sąveikaudamas su vidiniais biologiniais audiniais ir augliais.

Darbo metu buvo sukurtas kompiuterinis akies su augliu modelis, kurį naudojant nustatyta, jog tik centrinis ultragarsinės žiedinės gardelės elementas, naudojamas signalų priėmimo režimu leidžia priimti panašaus stiprumo signalus iš tiriamos zonos, o ne visi gardelės elementai. Signalo fokuso zonoje amplitudė priimant centriniu gardelės elementu tik -10 dB mažesnė nei priimant visais gardelės elementais.

Patekta spaudai 2011 11 30