

High efficiency multilayer gratings for monochromators in the energy range from 500 eV to 2500 eV

This content has been downloaded from IOPscience. Please scroll down to see the full text.

2013 J. Phys.: Conf. Ser. 425 152012

(<http://iopscience.iop.org/1742-6596/425/15/152012>)

View [the table of contents for this issue](#), or go to the [journal homepage](#) for more

Download details:

IP Address: 86.96.60.183

This content was downloaded on 18/10/2013 at 19:32

Please note that [terms and conditions apply](#).

High efficiency multilayer gratings for monochromators in the energy range from 500 eV to 2500 eV

**B Lagarde¹, F Choueikani^{1,2}, B Capitanio¹, P Ohresser¹, E Meltchakov²,
F Delmotte², M Krumrey³, F Polack¹**

¹ Synchrotron SOLEIL, L'Orme des Merisiers, Saint-Aubin, BP 48, 91192 Gif-sur-Yvette, France

² Laboratoire Charles Fabry, Institut d'Optique, CNRS, Université Paris Sud, 2 Avenue Augustin Fresnel, 91127 Palaiseau Cedex, France

³ Physikalisch-Technische Bundesanstalt (PTB), Abbestrasse 2-12, 10587 Berlin, Germany

francois.polack@synchrotron-soleil.fr

Abstract. Multilayer (ML) gratings have been prepared by coating shallow ion etched lamellar gratings with a Mo₂C/B₄C multilayer having a layer thickness close to the groove depth. It was shown that such a structure behaves as a 2D synthetic crystal and can reach very high efficiencies when the Bragg condition is satisfied. A ML coated grating has been characterized at the SOLEIL Metrology beamline between 700 and 1700 eV and a beamline of PTB at BESSY II between 1750 and 3500 eV. A peak diffraction efficiency of nearly 27 % was measured at 2200 eV. The measured efficiencies are well reproduced by numerical simulations made with the electromagnetic propagation code CARPEM. This grating will be used in the Deimos beamline at SOLEIL together with a matched multilayer mirror.

1. Introduction

In the photon energy range above 1.5 keV, diffraction gratings usually have a low efficiency (a few %) rapidly falling with increasing energy. Blazed gratings (triangular profile) behave slightly better than lamellar ones, but profiles with the required 1 to 2° blaze angle are difficult to produce and control on the large surface needed for implementation in a beamline monochromator [1]. Multilayer (ML) coated gratings have been used in EUV for a long time [2,3], and recently high efficiencies have been reported for several keV X-rays [4, 5].

At energies below 100 eV, ML gratings are used in nearly normal incidence and the ML coating simply enhances the efficiency by its reflectivity. The situation is different at energies above 1 keV because i) the ML period being much larger than the wavelength, the ML grating must be used in grazing incidence; ii) the penetration depth becomes such that the 2D structure, created by depositing a ML on a grating, behaves as a 2D crystal the unit cell of which is defined by both periods. If the Bragg condition is fulfilled, there is a strong preferential coupling into a single diffraction order while others, including zero order, nearly vanish [6]. In the ideal case depicted in figure 1, a perfect lamellar profile is coated with a perfect ML, and all the layers have a thickness equal to the grating groove depth. Then the cross section of the grating alternates the two materials in a checkerboard structure, and the Bragg

planes are defined by their angle with respect to the grating plane $\tan \theta_{i,n} = \frac{2m d}{n p}$

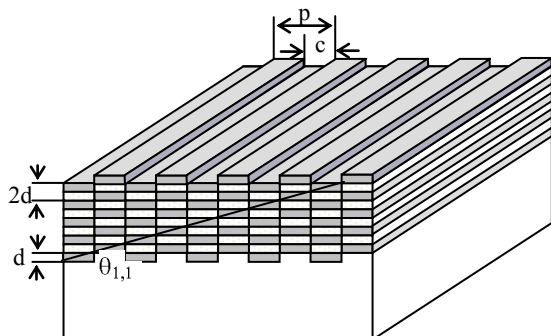

Figure 1. Simple binary model of an ideal alternate multilayer grating, realized on a lamellar grating of equal lands and grooves by deposition of a ML whose thickness of each material is equal to the groove depth. The oblique straight line marks the orientation of the (1,1) Bragg plane.

In practice this ideal alternate multilayer (AML) structure is never exactly achieved. Producing a grating suitable for use in a beamline monochromator requires several steps. First a lamellar grating is etched in silicon and its groove profile is measured with an AFM. Then the optimal layer thicknesses are determined from simulations with our electromagnetic propagation code CARPEM [7]. Finally, the ML is deposited with careful thickness control. Here are reported some results recently obtained on a 2400 l/mm lamellar grating for the monochromator of Deimos beamline at SOLEIL. The grating substrate was produced by Horiba Jobin-Yvon. It was coated with $\text{Mo}_2\text{C}/\text{B}_4\text{C}$ by magnetron sputtering at the Laboratoire Charles Fabry.

2. Manufacturing issues

The first difficulty to be faced in manufacturing AML gratings as described above is that the groove depth should be half the ML period. Simulations show the mismatch should not exceed 20%. In order to achieve decent reflectivity in the 1 to 2.5 keV range with a $\text{Mo}/\text{B}_4\text{C}$ ML, the period should be around 5 nm. Therefore, a (2.5 ± 0.5) nm groove depth should be achieved on the whole grating surface ($50 \times 20 \text{ mm}^2$). Obtaining a given groove depth within this level proved to be difficult and rather the retained strategy was to etch several gratings with a target depth value, measure them with the AFM on a sufficient number of points and then coat them with the ML of corresponding period.

A second issue is to realize the ML with the desired binary index profile. When controlling the first produced 5 nm period $\text{Mo}/\text{B}_4\text{C}$ ML by grazing incidence reflectivity with $\text{Cu K}\alpha$ X-rays, it was found that the reflectivity data could not be fitted by a two layer model but that a third layer with a refractive index close to that of MoB_2 was formed at the interface of B_4C deposited on Mo. This interdiffusion layer had a thickness of 1.1 to 1.2 nm [8]. Simulations with CARPEM showed that the efficiency could be almost recovered by making the Mo layer thinner, but controlling both the period and the Mo thickness was judged risky as the diffraction efficiency falls down quite fast with Mo thickness. The use of Mo_2C , which forms clean binary layers with B_4C , was finally preferred (figure 2)

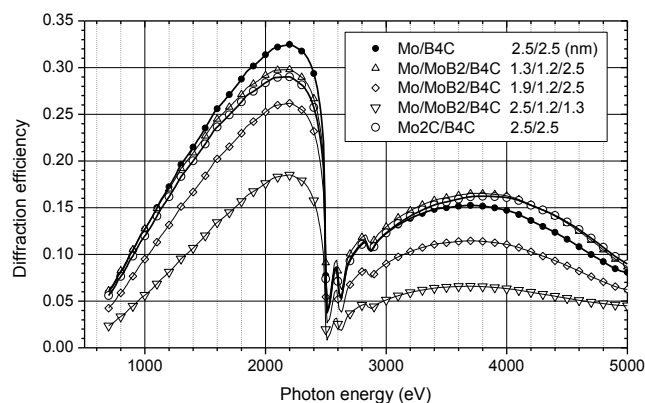

Figure 2. CARPEM computations of diffraction efficiencies of the same lamellar 2400 l/mm grating with a groove depth $d = 2.5$ nm a duty cycle $c/p = 0.45$, coated with 30 period MLs, according to the ML materials and thicknesses (nm) as indicated in the graph legend. The initial goal was $\text{Mo}/\text{B}_4\text{C}$ 2.5/2.5 nm but measurements revealed a 1.2 nm interdiffusion layer having the refractive index of MoB_2 . Therefore the stable combination $\text{Mo}_2\text{C}/\text{B}_4\text{C}$ was selected.

3. Characterization of the ML grating

During fabrication the thickness of deposited layers is measured by Cu $K\alpha$ grazing incidence reflectometry. It gives a good control on the achieved period with respect to the target value which is determined from AFM profile measurement of the uncoated grating. In the case of the 2400 l/mm grating Deimos-B2, a groove depth of 2.48 nm was measured and the target period was fixed to approx. 5 nm. The duty cycle, defined as groove width over grating period, was measured to be 0.45, slightly below the optimum value of 0.5. The deposited ML (30 layer pairs) was measured on the grating itself by reflectometry using Cu $K\alpha$ radiation, with the incidence plane parallel to the grating lines to avoid diffraction. We obtained 2.722 nm and 2.64 nm for the respective Mo_2C and B_4C thicknesses, hence a period of 5.362 nm.

The diffraction efficiency of this grating was measured at the low energy branch of the SOLEIL Metrology Beamline [9] in the energy range from 700 to 1700 eV, and at the four-crystal monochromator beamline of PTB at BESSY II in the energy range from 1750 to 3500 eV [10]. In figure 3 and 4, these measured values are compared to CARPEM simulations, assuming a perfect rectangular profile of the grooves and a perfect replication of this profile by the deposited ML.

A very good agreement is found between the measured angular reflectivity profile at 2200 eV and best fit simulations, as shown on figure 3. In the fitting process, the reflectivity profile is found most sensitive to the respective thickness of Mo_2C and B_4C . Small changes of thickness result in a shift of the angle of maximum reflectivity. The obtained thicknesses agree with grazing Cu $K\alpha$ measurements to better than 0.1%. The width of the profile depends on the number of layer periods. Almost perfect agreement is found for 30 periods. The duty cycle c/p affects the peak efficiency. The best agreement is found for 0.35 instead of the measured 0.45, but the other imperfections of the structure also contribute to reducing the efficiency from the computed 31% with $c/p = 0.45$ to the measured $\sim 27\%$.

Figure 4 confirms the ability to obtain a high diffraction efficiency throughout a wide energy range by keeping a constant grating rotation angle $\Omega = 0.692$. The angle Ω is defined as the grating rotation from specular reflection to achieve maximum efficiency, related to the grazing incidence and exit angles α and β by $\Omega = (\alpha - \beta)/2$. The angle Ω_p of maximum efficiency, the apparent Bragg angle, is slightly different from the Bragg angle calculated from the ratio of the two periods due to a small refraction effect at the grating surface which cannot be neglected. The effect is in perfect agreement with CARPEM code results.

In a beamline monochromator where a fixed exit direction is required, the ML grating should be paired with a mirror of same deviation. This mirror should also be ML coated and its angular reflectivity profile should have a maximum overlap with the grating one. Thanks to the constancy of Ω_p and its small value, the same ML coating with nearly the same period fulfills the condition.

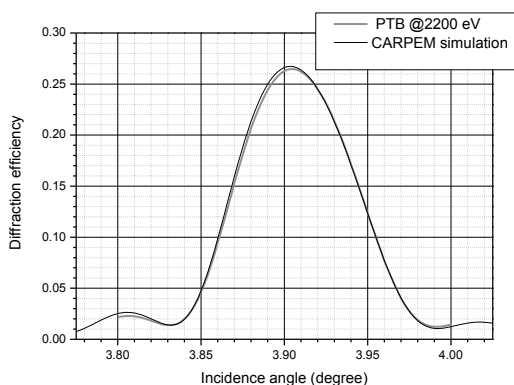

Figure 3. Reflectivity profile of the 1st diffraction order at 2200 eV. The values measured at PTB are compared to CARPEM simulations with 2.64 nm of B_4C , 2.722 nm of Mo_2C and $c/p=0.35$.

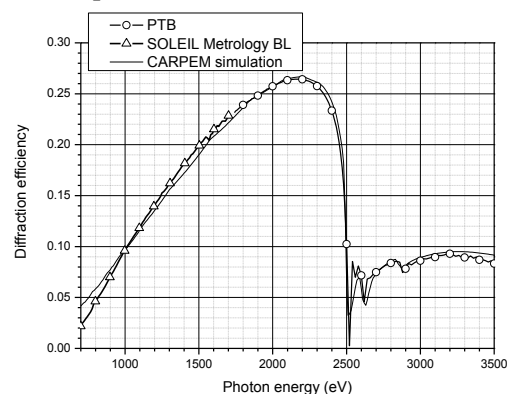

Figure 4. Measured efficiency in the range from 500 to 3500 eV for a rotation angle $\Omega = 0.692$, compared to CARPEM simulation with the same parameters as in fig. 3.

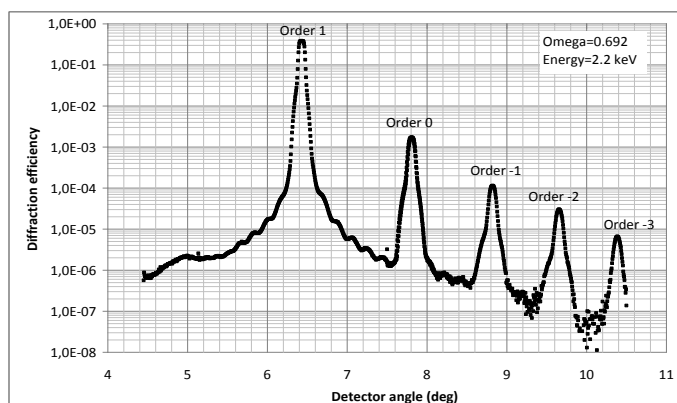

Figure 5. Detector scan measured at PTB for a constant incidence of 7.8° and a fixed energy of 2200 eV satisfying the Bragg condition. It shows a very strong suppression of all diffraction orders except the 1st order.

Figure 5 illustrates the preferential coupling of almost all the incident flux into one diffracted order when the Bragg condition is satisfied, which is a signature of 2D diffraction and explains why AML gratings can have very large efficiencies. It shows a detector scan at a fixed energy of 2200 eV and a constant incidence angle of 7.8° . Orders other than the 1st order are suppressed by a factor above 100.

4. Conclusion

We have fabricated a multilayer grating which has a very high efficiency in the photon energy range from 1000 to 2500 eV, by coating a lamellar grating of 2.5 nm groove depth with a $\text{Mo}_2\text{C}/\text{B}_4\text{C}$ multilayer of 5.3 nm period. This grating has been characterized throughout this range by measurements carried out at the SOLEIL Metrology beamline and at a PTB beamline at BESSY II. A peak efficiency of almost 27 % was measured at 2.2 keV. The efficiency curves are accurately simulated with our grating computation code CARPEM. Imperfections of the structure yield a reduced efficiency with respect to the measured groove to period ratio, but do not alter the others properties. The coating was made on a full size blank to be installed in the Deimos monochromator at SOLEIL.

References

- [1] Cocco D, Bianco A, Kaulich B, Schaefer F, Mertin M, Reichardt G, Nelles B, and Heidemann K F, 2007, AIP Conf. Proc. **879**, 497-500
- [2] Rife J C, Barbee Jr T W, Hunter W R, and Cruddace R G, 1990, Physica Scripta. **41**, 418
- [3] Voronov D L, Anderson E H, Gullikson E M, Salmassi F, Warwick T, Yashchuk V V, and Padmore H A, 2012, Opt. Lett. **37**, 1628-30
- [4] Masahiko I, Masato K, Futami S, Masami T, Kazuo S and Hiroyuki S, 2008, J. Appl. Phys. **104**, 073520
- [5] Voronov D, Anderson E, Cambie R, Gawlitza P, Goray L, Gullikson E, Salmassi F, Padmore H, 2012, these proceedings
- [6] Polack F, Lagarde B, Idir M, Liard A, Jourdain E, Roulliay M, Delmotte F, Gautier J, Ravet-Krill M F, 2007, AIP Conf. Proc. **879** 489-492
- [7] Mirone A, Delcamp E, Idir M, Cauchon G, Bizeuil C, Polack F and Dhez P, 1998, Appl. Optics **37**, 5816-22. CARPEM is a joint property of SOLEIL and Horiba Jobin-Yvon company.
- [8] Choueikani F, Delmotte F, Polack F, Bridou F, Lagarde B, Mercère P, Otero F and Ohresser F, 2012 these proceedings
- [9] Idir M, Mercère P, Moreno T, Delmotte A., Da Silva P, and Modi M. H. **2010** AIP Conf. Proc., **1234** 485-488.
- [10] Krumrey M and Ulm G 2001 Nuclear Instrum. Meth. 2000, A **467-468** 1175- 178