

Cancer Research



Novel Germline *p16* Mutation in Familial Malignant Melanoma in Southern Sweden

Åke Borg, Ulla Johansson, Oskar Johannsson, et al.

Cancer Res 1996;56:2497-2500. Published online June 1, 1996.

Updated Version

Access the most recent version of this article at:
<http://cancerres.aacrjournals.org/content/56/11/2497>

Citing Articles

This article has been cited by 15 HighWire-hosted articles. Access the articles at:
<http://cancerres.aacrjournals.org/content/56/11/2497#related-urls>

E-mail alerts

[Sign up to receive free email-alerts](#) related to this article or journal.

Reprints and Subscriptions

To order reprints of this article or to subscribe to the journal, contact the AACR Publications Department at pubs@aacr.org.

Permissions

To request permission to re-use all or part of this article, contact the AACR Publications Department at permissions@aacr.org.

Novel Germline *p16* Mutation in Familial Malignant Melanoma in Southern Sweden¹

Åke Borg,² Ulla Johansson, Oskar Johannsson, Sara Håkansson, Johan Westerdahl, Anna Måsbäck, Håkan Olsson, and Christian Ingvar

Departments of Oncology [Å. B., U. J., O. J., S. H., H. O.], Surgery [J. W., C. I.], and Pathology [A. M.], University Hospital, S-221 85 Lund, Sweden

Abstract

The *p16* (*CDKN2/MTS1/INK4a*) malignant melanoma susceptibility gene was analyzed in 10 melanoma kindreds from southern Sweden using single-stranded conformation polymorphism analysis of all three exons and flanking intron regions followed by sequence analysis. A novel germline mutation, constituting an in-frame 3-bp duplication at nucleotide 332 in exon 2, was identified in two families (Lund M2 and M9). The mutation results in an insertion of Arg at codon 105, which interrupts the last of the four ankyrin repeats of the p16 protein, motifs which have been demonstrated as important in binding and inhibiting the activity of cyclin D-dependent kinases 4 and 6 in cell cycle G₁ phase regulation. All five tested individuals of Lund M2 and M9 affected by melanoma were mutation carriers, as were five melanoma-free individuals. Other malignancies observed in gene carriers or obligate carriers included cervical, breast, and pancreatic carcinomas and a non-Hodgkin's lymphoma. Analysis of microsatellite markers adjacent to the *p16* gene at chromosomal region 9p21 revealed that both families share a common haplotype, in keeping with a common ancestor.

Introduction

Approximately 10% of cutaneous malignant melanomas occur in individuals with a genetic predisposition for the disease, often in association with multiple dysplastic nevi (1). A major familial malignant melanoma susceptibility locus (*MLM*) has been identified on chromosome 9p21 by linkage analysis in families from different populations (2-4), whereas the evidence of a second susceptibility locus on chromosome 1p36 is less compelling (5). The gene (*p16*, *CDKN2*, *MTS1*, *INK4a*) for a previously identified cell cycle regulator (6) was localized to chromosome 9p21 and found altered by mutations or homozygous deletions in a wide range of tumor cell lines, including 60% of melanoma tumor cell lines (7). The p16 product belongs to a family of low molecular weight proteins that bind to cyclin-dependent kinases 4 and 6 (CDK4 and CDK6) and inhibit their ability to interact with cyclin D products in stimulation of G₁ progression. Its growth-suppressing effects have been observed in Ras-transformed cells by ectopic expression of p16 (8). Although less frequently altered in primary tumors, somatic intragenic mutations are common in pancreatic cancer (9) and esophageal squamous cell carcinoma (10), supporting the role of *p16* as a multiple tumor suppressor gene. In other tumor types, the 9p21 region is often altered by hemizygous deletions without concomitant *p16* mutation (11), suggesting the presence of additional target genes in the region. However, transcriptional silencing of the *p16* gene by methylation of upstream CpG islands was

recently invoked as an alternate mechanism in gene inactivation (12), again emphasizing *p16* as the important gene of the 9p21 region but also the presence of an "imprinter" gene (13).

The demonstration of germline mutations in a proportion of 9p21-linked families suggests that *p16* indeed is a strong candidate for the *MLM* gene (14-16). Moreover, analysis of 15 Dutch families with malignant melanoma and multiple dysplastic nevi revealed an identical 19-bp germline deletion within exon 2 of the *p16* gene in 13 of them (17). We have earlier reported from our continuous investigations of hereditary cancer in southern Sweden and about the presence of founder effect mutations in the *BRCA1* gene in familial breast and ovarian cancer (18). In the present initial genetic analysis of familial melanoma from southern Sweden, we found indications of a similar founding mutation, evident as a repeatedly occurring novel *p16* germline mutation.

Materials and Methods

Patients. Ten patients with cutaneous malignant melanoma and at least one first-degree relative with the disease were included in the analysis. All were Caucasian and diagnosed within the South Swedish Health Care Region, which contains approximately 20% of the total Swedish population. Cases were identified from patients treated at the Department of Surgery, University Hospital, in Lund. None of the included families were found to be related when traced back to approximately year 1850. Peripheral blood was obtained from index patients and relatives for DNA extraction and mutation analysis.

SSCP³ Analysis. Primer sequences for PCR amplification of all three exons and flanking intron regions of the *p16* gene were as described previously (14). PCR was carried out in 30- μ l volumes containing 100 ng of genomic DNA; 1 \times PCR buffer; 0.3 mM each of dATP, dGTP, and dTTP; 16 μ M dCTP; 0.24 μ l [α -³²P]dCTP (10 μ Ci/ μ l, 3000 Ci/mmol; Amersham); 0.5 μ M of each primer; 1.0 mM Mg₂Cl₂; 1.0 unit Taq polymerase (MBI Fermentas); 5% DMSO; 0.1 mg/ml BSA; and ddH₂O up to 30 μ l. PCR was performed in an Omnigene Thermal Cycler (Hybaid), using an initial denaturation at 92°C for 5 min, followed by 30 cycles consisting of 92°C for 30 s, 55-65°C for 30 s, and 72°C for 45 s, and a final extension at 72°C for 10 min. SSCP analysis was carried out at both room and +4°C temperature. Three μ l of the samples were mixed with 12-27 μ l denaturing loading buffer (95% formamide, 10 mM NaOH, 0.05% xylene cyanol, and 0.05% bromophenol blue), denatured for 5 min at 95°C, and cooled on ice. A 60-ml gel contained 0.5 \times Hydrolink MDE (AT Biochem), 0.6 \times TBE, ddH₂O up to 60 ml, 240 μ l 20% ammonium persulfate, and 24 μ l tetramethylethylenediamine. For gels run at room temperature, 5% glycerol was added to the gel. Gels were run in 0.6 \times TBE buffer for 16-18 h at 6-10 W at room temperature or for 4-6 h at 35-40 in 4°C, and thereafter transferred to chromatography paper, covered with plastic wrap, and placed on Cronex4 X-ray film (DuPont) at -70°C for 2-48 h. Shifts in both single- and double-stranded (heteroduplexes) DNA migration were evaluated.

Sequencing. Variant bands were cut out from SSCP gels, rehydrated in 100 μ l ddH₂O, and incubated at 65°C for 15 min. One to 2 μ l were used in a new PCR, using identical programs as above, except for using 0.2 mM of each dNTP and excluding radioactive dCTP. When not possible to use variant bands

Received 3/4/96; accepted 4/11/96.

The costs of publication of this article were defrayed in part by the payment of page charges. This article must therefore be hereby marked *advertisement* in accordance with 18 U.S.C. Section 1734 solely to indicate this fact.

¹ This study was supported by grants from the Swedish Cancer Society; the Mrs. Berta Kamprad Foundation; the Medical Faculty University of Lund; the Cancer & Trafikskadades Riksförbund; the Gunnar, Arvid, and Elisabeth Nilsson Cancer Foundation; and the Crafoord Foundation.

² To whom requests for reprints should be addressed. Phone: (46) 46 177569; Fax: (46) 46 147327; E-mail: ake.borg@onk.lu.se.

³ The abbreviations used are: SSCP, single-stranded conformational polymorphism; dNTP, deoxynucleotide triphosphate; HPV, human papillomavirus.

as templates for sequencing. PCR was carried out on genomic DNA. A biotin-labeled reverse primer was used in both types of reactions. Single-stranded PCR products were isolated by capturing to avidin-coated magnetic beads (Dynazyme) and subjected to the Sanger dideoxynucleotide chain termination DNA sequencing, using a Sequenase Dye Terminator single-stranded sequencing kit, a 373 Sequencer (Applied Biosystems), and the PCR-forward primer as sequencing primer.

PCR-Microsatellite Analysis. Primers or primer sequences for the dinucleotide microsatellite markers flanking the *p16* gene on chromosome 9p21 were obtained from Research Genetics (Huntsville, MA) or from the Genomic DataBase (<http://gdbwww.gdb.org>; Ref. 19). The markers included (from telomere to centromere): *IFNA*, *D9S1751*, *D9S1749*, *D9S1747*, *D9S1748*, *D9S1752*, and *D9S171*. The 50- μ l PCR mixture contained 10 mM Tris-HCl (pH 8.8), 50 mM KCl, 1.0 mM MgCl₂, 5 μ g BSA (0.1 mg/ml), 5% DMSO, 0.8 mM dNTPs, 1.25 unit of Taq polymerase (MBI Fermentas), 0.25 μ M of each primer, and 100 ng of genomic DNA. PCR was run as follows: 1 cycle of 5 min at 92°C, followed by 26–32 cycles of 30 s at 92°C, 30 s at 57–60°C, 45 s at 72°C, followed by 1 cycle of 10 min at 72°C. Four μ l PCR product was mixed with 8 μ l denaturing loading buffer (95% deionized formamide, 10 mM EDTA, 0.05% bromophenol blue, and 0.05% xylene cyanol), heated 10–20 min at 94°C, cooled on ice, and loaded (3 μ l) on 0.4-mm thick preheated and denaturing (8 M urea) 6% polyacrylamide gels for electrophoresis at 80 W (30-cm-wide gels) during 1–2 h. The separated DNA fragments were blotted onto Hybond N+ (Amersham) and hybridized with one of the PCR primers, randomly tailed with dNTPs and terminal deoxynucleotide transferase (Amersham), using an ECL direct nucleic acid labeling and detection system (Amersham) and placed on a blue light-sensitive film (Cronex-4; DuPont). Allele sizes were compared between individuals of different families.

Results

Two of ten southern Swedish melanoma families (Lund M2 and Lund M9), analyzed in the present study, were found to carry an identical and novel germline mutation in exon 2 of the *p16* gene. The mutation was detected by SSCP and heteroduplex analysis and by sequencing identified as an in-frame 3-bp insertion (duplication) at nucleotide 332 [according to the cDNA sequence of Serrano *et al.* (6)], resulting in an arginine insertion at codon 105. A known polymorphism, Ala140Thr (G436A), in exon 2 was observed in two families. Moreover, a single base pair substitution (G494C) residing in the 3' untranslated region of exon 3 was identified in one family. The G494C substitution was subsequently observed in healthy control individuals and represents, in all likelihood, a normal polymorphic variant.

Lund M2 is a kindred with five cases of malignant melanoma (ages of onset, 35, 40, and 49 years, with the two remaining at unknown age), three of which were tested and found to carry the 3-bp insertion (Fig. 1). Three mutation carriers are disease free at ages 33, 47, and 61, respectively, and one obligate carrier died at age 56 without signs of melanoma. Conversely, three unaffected individuals were identified as non-carriers of the mutation. Thus, the gene penetrance in Lund M2 is presently 50% (three melanoma cases among six carriers). Two females (one gene carrier and one of unknown gene status) developed cervical carcinoma at ages 23 and 27 (an additional *in situ* cervical carcinoma at age 32), respectively. One female gene carrier affected by melanoma subsequently developed breast cancer at age 60.

Lund M9 is a kindred with two females affected by melanoma (Fig. 1), both of which were found to carry the 3-bp insertion. The proband developed two primary melanomas at ages 56 and 57 but also cervical carcinoma at age 51 and non-Hodgkin's lymphoma at age 38. Her daughter developed two primary melanomas at ages 23 and 29. Moreover, the proband's mother (not tested) developed pancreatic carcinoma at age 71, whereas a stomach and an endometrial cancer were present in the paternal branch of the proband. Two gene carriers were disease free at ages 21 and 37, resulting in a gene penetrance of

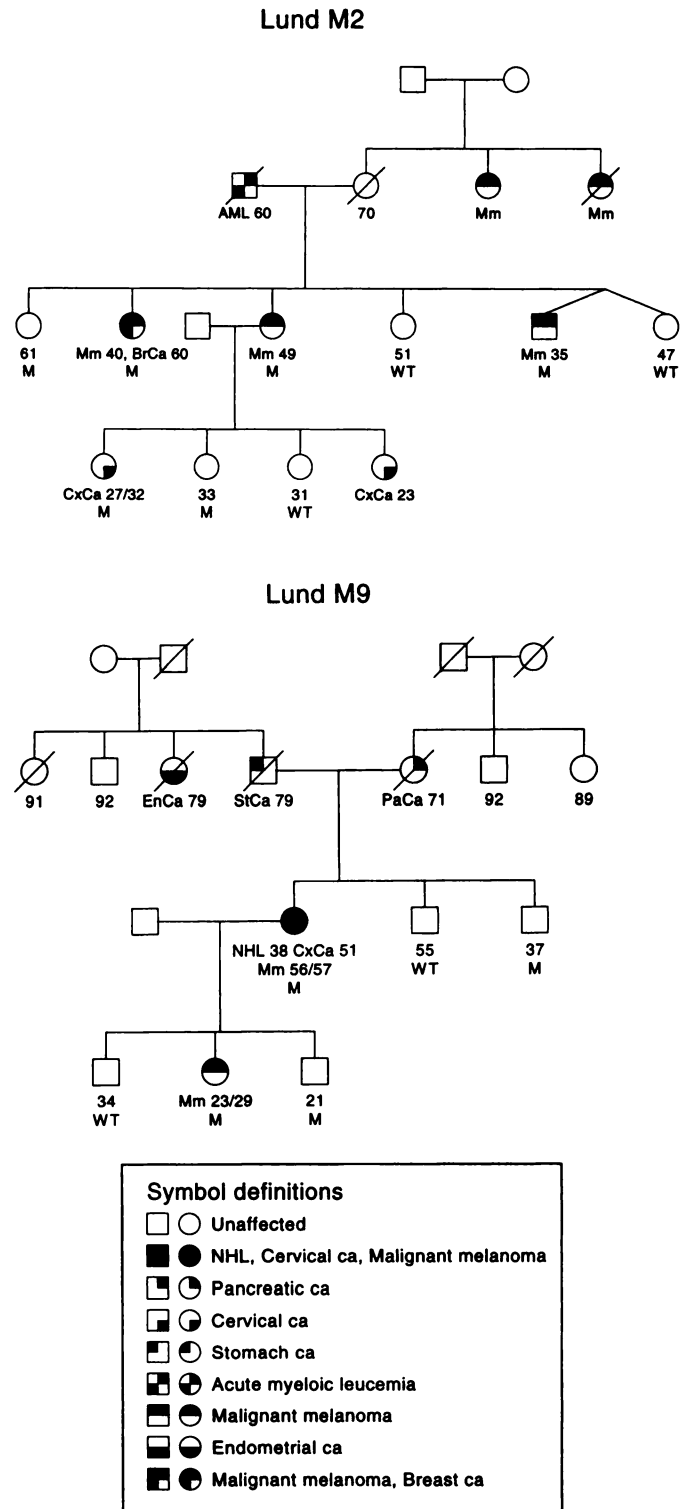

Fig. 1. Pedigree structure for kindred Lund M2 and Lund M9. Malignant diseases and ages of onset, or current disease-free age, are shown beneath each symbol. *Mm*, malignant melanoma; *BrCa*, breast cancer; *AML*, acute myeloid leukemia; *CxCa*, cervical carcinoma; *PaCa*, pancreatic cancer; *NHL*, non-Hodgkin's lymphoma; *EnCa*, endometrial cancer; *StCa*, stomach cancer. *p16* mutation status is indicated as *M* (carrier of the 105insArg mutation) or *WT* (wild-type sequence).

50%. Lund M2 and M9 were found to carry a common haplotype for markers flanking the *p16* gene on chromosome 9p21 (*IFNA*, *D9S1751*, *D9S1749*, *D9S1747*, *D9S1748*, *D9S1752*, and *D9S171*), supporting a common ancestor for these families.

Discussion

The p16 tumor suppressor protein binds to the cyclin-dependent kinases CDK4 and CDK6, preventing their activation by cyclin D and thereby the phosphorylation of the retinoblastoma susceptibility gene product (pRB) and pRB-related proteins involved in regulation of G₁ phase progression (20). The p16 protein contains four ankyrin repeats, motifs which are recognized in protein-protein interaction and, in the case of p16, probably in the interaction with CDK4 and CDK6 (6). Earlier investigations have demonstrated that mutations affecting the consensus amino acid residues of the ankyrin repeats also reduce the binding and inhibitory activity of p16, whereas mutations at non-conserved residues within the ankyrin repeats or at residues outside these repeats have minor functional effects (21–23). Moreover, it was recently demonstrated that a melanoma cell line manifested a mutation in the p16 binding domain of the *CDK4* gene product (24). The same *CDK4* mutation was subsequently detected in the germline of a melanoma kindred (25), further strengthening the important role of aberrations in this cell cycle pathway in malignant melanoma development.

The 105 Arg insertion, identified in two kindreds of the present study, reside in the beginning of the fourth ankyrin repeat inserted between conserved (underlined) amino acid residues (WGRLPV to WGRRLPV). The functional effect of this previously unreported mutation, *i.e.*, the interaction of the mutant p16 protein with CDK4, is presently under analysis.⁴ The fact that all five tested individuals with malignant melanoma in Lund M2 and M9 are carriers of the mutation supports its role in disease development. On the other hand, five mutation carriers were melanoma free at the ages of 34 to 61 years, which is in agreement with the calculated penetrance of 53% by age 80 for carriers of the *9p21* gene (26). It is of considerable interest that other malignant diseases are found repeatedly in mutation carriers, obligate carriers, and descendants of carriers in Lund M2 and M9. A pancreatic cancer was found in an obligate carrier of Lund M9, lending support to earlier observations of a connection between an increased risk of both melanoma and pancreatic cancer in the familial atypical multiple mole melanoma syndrome (27–29). Pancreatic cancer is also one of the few tumor types with a reported high frequency of somatic *p16* mutations (9). One female gene carrier affected by malignant melanoma also subsequently developed breast cancer. This raises the question if germline *p16* mutations are also involved in predisposition for this heterogeneous disease, although her relatively high age at diagnosis (60 years) indicates that she may have developed a sporadic breast cancer. However, another female gene carrier has developed three independent malignant diseases (melanoma, cervical carcinoma, and non-Hodgkin's lymphoma), emphasizing the role of *p16* as a multitumor suppressor gene.

Three individuals with cervical squamous cell carcinoma were detected in Lund M2 and M9, two of which were tested and found to be gene carriers. Two of them developed the disease at a very young age and/or had multiple primary tumors. Although no association has been reported to exist between malignant melanoma and cervical carcinoma, somatic *p16* mutations have previously been found in squamous cell carcinomas of the esophagus (10). It cannot be excluded that inactivation of the p16 protein in cervical carcinomas in part has a similar effect as inactivation of pRB by complex binding to the E7 protein of HPV types 16 and 18, which are known carcinogens in cervical carcinoma development. p16 and pRB participate in a common growth regulatory pathway, and there seems to exist an inverse relationship between functional disruptions of the *p16* and *RB1* genes in human cancers (23, 30). It will be of interest to

investigate whether the cervical carcinomas in Lund M2 and M9 are HPV negative and, indeed, carry somatic mutations in the *p53* gene. HPV-positive cervical carcinomas have usually retained a wild-type *p53* gene but have an impaired p53 function due to protein degradation via binding to the E6 viral oncoprotein.

The number of germline *p16* mutations identified to date is still low (14–17), although certain mutations are repeatedly found in independent families. For instance, Gly93Trp has been identified in kindreds Utah 3012 and NIH 1017, and Val118Asp has been identified in kindreds in Utah 1771 and NIH 1016. Moreover, 13 of 15 Dutch melanoma kindreds analyzed were found to carry an identical 19-bp deletion at nucleotide 218, providing strong support for the presence of a common ancestor. Similarly, the two families of the present study being found to carry an identical 3-bp insertion are most likely related, because they share common alleles of microsatellite markers proximate to *p16* at 9p21.

Although *p16* is a strong candidate for the *MLM* gene on chromosome 9, far from all 9p21-linked melanoma families have been shown to carry germline *p16* mutations (14–16). This may be interpreted as being due to gene inactivation by other mechanisms than mutation in coding and splice site regions. Alterations in promoter/enhancer elements operating in regulation of gene transcription may exist, as may mutations affecting transcript stability/translation efficacy. The existence of a chromosome 9p imprinter gene has recently also been emphasized (12, 13) by drawing parallels with the proposed activity of the *H19* gene in specific methylation of the *IGF2* promoter region, with both the latter genes being clustered on chromosomal region 11p15. The potential role of other adjacent genes also has not been ruled out. For instance, the involvement of the *p15/MTS2/INK4b* gene (7) in familial melanoma is still mostly unexplored. Its proximity to the *p16* gene on 9p21 has been taken as an explanation for the strong selection for homozygous deletions in certain malignancies such as astrocytoma and leukemia (preferentially acute lymphocyte leukemia), affecting both genes rather than inactivation of *p16* by point mutation followed by hemizygous deletion (31, 32).

In conclusion, an initial genetic analysis of familial malignant melanoma in southern Sweden has provided some evidence of a repeatedly occurring novel *p16* mutation within the population. The frequent occurrence also of other tumor types in mutation carriers suggests that germline *p16* mutations are involved in predisposition to several malignancies, similar to the broad range of tumors found to manifest somatic *p16* alterations. The possible existence of a *p16* mutation founder effect in Sweden will facilitate future genetic screening and also provides an opportunity to study disease penetrance and effect of risk factors such as skin pigmentation, number of melanocytic nevi, sun exposure, propensity to sunburn, and others on the background of common genetic susceptibility.

References

- Skolnick, M. H., Cannon-Albright, L. A., and Kamb, A. Genetic predisposition to melanoma. *Eur. J. Cancer*, 30A: 1991–1995, 1994.
- Cannon-Albright, L. A., Goldgar, D. E., Meyer, L. J., Lewis, C. M., Anderson, D. E., Fountain, J. W., Hegi, M. E., Wiseman, R. W., Petty, E. M., Bale, A. E., Olopade, O. I., Diaz, M. O., Kwiatkowski, D. J., Piepkorn, M. W., Zone, J. J., and Skolnick, M. H. Assignment of a locus for familial melanoma, MLM, to chromosome 9p13–p22. *Science* (Washington DC), 258: 1148–1152, 1992.
- Goldstein, A. M., Dracopoli, N. C., Engelstein, M., Fraser, M. C., Clark, W. H., and Tucker, M. A. Linkage of cutaneous malignant melanoma/dysplastic nevi to chromosome 9p, and evidence for genetic heterogeneity. *Am. J. Hum. Genet.*, 54: 489–496, 1993.
- Nancarrow, D. J., Palmer, J. M., Walters, N. K., Kerr, G. J., Hafner, L., Garske, R., McLeod, R., and Hayward, N. K. Confirmation of chromosome 9p linkage in familial melanoma. *Am. J. Hum. Genet.*, 53: 936–942, 1993.
- Bale, S. J., Dracopoli, N. C., Tucker, M. A., Clark, W. H., Fraser, M. C., Stanger, B. Z., Green, P., Donis-Keller, H., Housman, D. E., and Greene, M. H. Mapping the gene for hereditary cutaneous malignant melanoma-dysplastic nevus to chromosome 1p. *N. Engl. J. Med.*, 320: 1367–1372, 1989.
- Serrano, M., Hannon, G. J., and Beach, D. A new regulatory motif in cell-cycle

⁴ R. Sikorski, personal communication.

- control causing specific inhibition of cyclin D/CDK4. *Nature (Lond.)*, 366: 704–707, 1993.
7. Kamb, A., Gruis, N. A., Weaver-Feldhaus, J., Liu, Q., Harshman, K., Tavtigian, S. V., Stockert, E., Day, R. S., III, Johnson, B. E., and Skolnick, M. H. A cell cycle regulator potentially involved in genesis of many tumor types. *Science (Washington DC)*, 264: 436–440, 1994.
 8. Serrano, M., Gómez-Lahoz, E., DePinho, R. A., Beach, D., and Bar-Sagi, D. Inhibition of ras-induced proliferation and cellular transformation by p16-INK4. *Science (Washington DC)*, 267: 249–252, 1995.
 9. Caldas, C., Hahn, S. A., da Costa, L. T., Redston, M. S., Schutte, M., Seymour, A. B., Weinstein, C. L., Hruban, R. H., Yeo, C. J., and Kern, S. E. Frequent somatic mutations and homozygous deletions of the *p16 (MTS1)* gene in pancreatic adenocarcinoma. *Nat. Genet.*, 8: 27–32, 1994.
 10. Mori, T., Miura, K., Aoki, T., Nishihira, T., Mori, S., and Nakamura, Y. Frequent somatic mutation of the *MTS1/CDK41* (multiple tumor suppressor/cyclin-dependent kinase 4 inhibitor) gene in esophageal squamous cell carcinoma. *Cancer Res.*, 54: 3396–3397, 1994.
 11. Cairns, P., Mao, L., Merlo, A., Lee, D. J., Schwab, D., Eby, Y., Tokino, K., van der Riet, P., Blaugrund, J. E., and Sidransky, D. Rates of p16 (*MTS1*) mutations in primary tumors with 9p21 loss. *Science (Washington DC)*, 265: 415–416, 1994.
 12. Merlo, A., Herman, J. G., Mao, L., Lee, D. J., Gabrielson, E., Burger, P. C., Baylin, S. B., and Sidransky, D. 5' CpG island methylation is associated with transcriptional silencing of the tumour suppressor p16/CDKN2/MTS1 in human cancers. *Nat. Med.*, 1: 686–692, 1995.
 13. Little, M., and Wainwright, B. Methylation and p16: suppressing the suppressor. *Nat. Med.*, 1: 633–634, 1995.
 14. Hussussian, C. J., Struewing, J. P., Goldstein, A. M., Higgins, P. A. T., Ally, D. S., Sheahan, M. D., Clark, W. H., Jr., Tucker, M. A., and Dracopoli, N. C. Germline p16 mutations in familial melanoma. *Nat. Genet.*, 8: 15–21, 1994.
 15. Kamb, A., Shattuck-Eidens, D., Eeles, R., Liu, Q., Gruis, N. A., Ding, W., Hussey, C., Tran, T., Miki, Y., Weaver-Feldhaus, J., McClure, M., Aitken, J. F., Anderson, D. E., Bergman, W., Frants, R., Goldgar, D. E., Green, A., MacLennan, R., Martin, N. G., Meyer, L. J., Youl, P., Zone, J. J., Skolnick, M. H., and Cannon-Albright, L. A. Analysis of the *p16* gene (*CDKN2*) as a candidate for the chromosome 9p melanoma susceptibility locus. *Nat. Genet.*, 8: 22–26, 1994.
 16. Walker, G. J., Hussussian, C. J., Flores, J. F., Glendening, J. M., Haluska, F. G., Dracopoli, N. C., Hayward, N. K., and Fountain, J. W. Mutations of the *CDKN2/p16INK4* gene in Australian melanoma kindreds. *Hum. Mol. Genet.*, 4: 1845–1852, 1995.
 17. Gruis, N. A., van der Velden, P. A., Sandkuijl, L. A., Prins, D. E., Weaver-Feldhaus, J., Kamb, A., Bergman, W., and Frants, R. R. Homozygotes for *CDKN2 (p16)* germline mutation in Dutch familial melanoma kindreds. *Nat. Genet.*, 10: 3511–353, 1995.
 18. Johansson, O., Ostermeyer, E. A., Håkansson, S., Friedman, L. S., Johansson, U., Sellberg, G., Brøndum-Nielsen, K., Sele, V., Olsson, H., King, M.-C., and Borg, Å. Founding BRCA1 mutations in hereditary breast/ovarian cancer from South Sweden. *Am. J. Hum. Genet.*, 58: 441–450, 1996.
 19. Cairns, P., Polascik, T. J., Eby, Y., Tokino, K., Califano, J., Merlo, A., Mao, L., Herath, J., Jenkins, R., Westra, W., Rutter, J. L., Buckler, A., Gabrielson, E., Tockman, M., Cho, K. R., Hedrick, L., Bova, G. S., Isaacs, W., Koch, W., Schwab, D., and Sidransky, D. Frequency of homozygous deletion at p16/CDKN2 in primary human tumours. *Nat. Genet.*, 11: 210–212, 1995.
 20. Sherr, C. J., and Roberts, J. M. Inhibitors of mammalian G1 cyclin-dependent kinases. *Genes & Dev.*, 9: 1149–1163, 1995.
 21. Yang, R., Gombart, A. F., Serrano, M., and Koeffler, H. P. Mutational effects on the p16-INK4a tumor suppressor protein. *Cancer Res.*, 55: 2503–2506, 1995.
 22. Ranade, K., Hussussian, C. J., Sikorski, R. S., Varmus, H. E., Goldstein, A. M., Tucker, M. A., Serrano, M., Hannon, G. J., Beach, D., and Dracopoli, N. C. Mutations associated with familial melanoma impair p16-INK4 function. *Nat. Genet.*, 10: 114–116, 1995.
 23. Lukas, J., Parry, D., Aagaard, L., Mann, D. J., Bartkova, J., Strauss, M., Peters, G., and Bartek, J. Retinoblastoma protein-dependent cell-cycle inhibition by the tumour suppressor p16. *Nature (Lond.)*, 375: 503–506, 1995.
 24. Wölfel, T., Hauer, M., Schneider, J., Serrano, M., Wölfel, C., Klehmann-Hieb, E., De Plaen, E., Hankeln, T., Meyer zum Büschenfelde, K.-H., and Beach, D. A p16-INK4a insensitive CDK4 mutant targeted by cytolytic T lymphocytes in a human melanoma. *Science (Washington DC)*, 269: 1281–1284, 1995.
 25. Zou, L., Weger, J., Yang, Q., Goldstein, A. M., Tucker, M. A., Walker, G. J., Hayward, N., and Dracopoli, N. C. Germline mutations in the p16-INK4a binding domain of CDK4 in familial melanoma. *Nat. Genet.*, 12: 97–99, 1996.
 26. Cannon-Albright, L. A., Meyer, L. J., Goldgar, D. E., Lewis, C. M., McWhorter, W. P., Jost, M., Harrison, D., Anderson, D. E., Zone, J. J., and Skolnick, M. H. Penetrance and expressivity of the chromosome 9p melanoma susceptibility locus (*MLM*). *Cancer Res.*, 54: 6041–6044, 1994.
 27. Bergman, W., Watson, P., de Jong, J., Lynch, H. T., and Fusaro, R. M. Systemic cancer and the FAMMM syndrome. *Br. J. Cancer*, 61: 932–936, 1990.
 28. Goldstein, A. M., Fraser, M. C., Struewing, J. P., Hussussian, C. J., Ranade, K., Zametkin, D. P., Fontaine, L. S., Organic, S. M., Dracopoli, N. C., Clark, W. H., Jr., and Tucker, M. A. Increased risk of pancreatic cancer in melanoma-prone kindreds with p16INK4 mutations. *N. Engl. J. Med.*, 333: 970–974, 1995.
 29. Whelan, A. J., Bartsch, D., and Goodfellow, P. J. A familial syndrome of pancreatic cancer and melanoma with a mutation in the *CDKN2* tumor suppressor gene. *N. Engl. J. Med.*, 333: 975–977, 1995.
 30. Otterson, G. A., Kratzke, R. A., Coxon, A., Kim, Y. W., and Kaye, F. J. Absence of p16(INK4) protein is restricted to the subset of lung cancer cell lines that retains wildtype RB. *Oncogene*, 9: 3375–3378, 1994.
 31. Jen, J., Harper, J. W., Bigner, S. H., Bigner, D. D., Papadopoulos, N., Markowitz, S., Willson, J. K. V., Kinzler, K. W., and Vogelstein, B. Deletion of *p16* and *p15* genes in brain tumors. *Cancer Res.*, 54: 6353–6358, 1994.
 32. Haidar, M. A., Cao, X. B., Manshour, T., Chan, L. L., Glassman, A., Kantarjian, H. M., Keating, M. J., Beran, M. S., and Albitar, M. *P16(INK4A)* and *p15(INK4B)* gene deletions in primary leukemias. *Blood*, 86: 311–315, 1995.